

Descriptive Technical Documentation

- Model-dependent -

DTD no. 511-6055

Model(s): PW 6055, PW 6065, PW 5065

Contents

General Information

- A** **Warning and Safety Instructions**
- B** **Modification History**
- C** **Technical Data**
- D** **Layout of Electrical Components**

Function Groups

030	Suds container, drum, bearings, heater element	
1	Technical Data	030-2
2	Function	030-3
2.1	Heating	030-3
2.2	Foam sensing	030-3
2.2.1	Excess foam when heating during the main wash	030-3
2.2.2	During rinse water intake excess foam is in the drum vent or odour trap	030-3
2.2.3	During spinning excess foam is in the drum (water around drum circumference registered)	030-3
4	Service	030-5
4.1	NTC temperature sensor, R30	030-5
4.2	Drum neck/suds container spacing gap setting	030-5
040	Water intake	
2	Function	040-2
2.1	Water path control unit and motor, M24	040-2
2.2	Water intake monitoring	040-2
2.3	Water overflow monitoring	040-2
2.4	Alternative water	040-2
2.5	External dispensing	040-3
2.6	External dispensing	040-4
4	Service	040-5
4.1	Alternative water valve fitting	040-5
4.2	Dispenser unit connection	040-7
050	Drainage via drain valve	
2	Function	050-2
2.1	Drainage monitoring	050-2

060	Drainage via drain pump	
2	Function	060-2
2.1	Drainage monitoring	060-2
070	3-phase motor	
1	Technical Data	070-2
3	Fault Repair	070-3
3.1	Drive failure	070-3
080	Fascia panel, control module	
2	Function	080-2
2.1	Reset signal for payment system	080-2
2.2	Time of day programmable function	080-2
2.3	Free spin programmable function	080-2
2.4	Language programmable function	080-3
2.5	Payment system programmable function	080-3
2.6	Operator code programmable function	080-3
2.7	Max. speed programmable function	080-4
2.8	Imbalance level programmable function	080-4
2.9	Heater rating programmable function	080-4
2.10	Heating programmable function	080-4
2.11	Temperature reduction programmable function	080-4
2.12	Control programmable function	080-5
2.13	Drum lighting programmable function	080-5
2.14	Standard settings programmable function	080-5
3	Fault Repair	080-6
3.1	Demonstration mode	080-6
3.2	Fault indication: Lamp defective	080-6
3.3	Fault indication: Technical fault	080-7
3.4	F 0 , no fault	080-8
3.5	Fault code F 1 , water/heating NTC sensor short-circuited	080-8
3.6	Fault code F 2 , water/heating NTC sensor	080-9
3.7	Fault code F10 , cold water intake	080-9
3.8	Fault code F11 , water drainage	080-11
3.9	Fault code F15 , hot water intake	080-12
3.10	Fault code F16 , excess foam	080-13
3.11	Fault code F20 , heating	080-14
3.12	Fault code F41 , faulty EEPROM / data fault	080-14
3.13	Fault code F43 , model type not programmed	080-15
3.14	Fault code F44 , I ² C bus connection faulty	080-15
3.15	Fault code F45 , faulty flash RAM / incorrect data	080-16
3.16	Fault code F46 , display fault	080-16
3.17	Fault code F47 , selection module (EW) – Power-programme module (ELP) interface fault	080-16
3.18	Fault code F50 , drive fault	080-17
3.19	Fault code F51 , pressure sensor	080-17
3.20	Fault code F53 , tachogenerator	080-18
3.21	Fault code F56 , no spin	080-19
3.22	Fault code F63 , water path control unit	080-19
3.23	Fault code F65 , drum lighting cap missing	080-20

4	Service	080-21
4.1	Programming mode summary	080-21
4.2	Programming mode summary	080-25
4.3	Demonstration mode activation / deactivation	080-29
4.4	Demonstration mode activation / deactivation	080-30
4.5	Service mode summary	080-31
4.6	Service mode summary	080-35

090 Electrical components

2	Function	090-2
2.1	Payment system socket (X1/1)	090-2
2.2	Payment system	090-2
2.3	Central control via RS 232 interface with 9-pole plug	090-3
4	Service	090-4
4.1	Working on frequency converter electronic unit (EFU)	090-4
4.2	Fitting payment system on machine lid	090-4
4.3	Payment system (programme operation)	090-6
4.4	Payment system (timed operation)	090-7
4.5	Central control via RS 232 interface	090-8

A Warning and Safety Instructions

1 General information

Service and repair work should only be carried out by suitably qualified persons in accordance with all appropriate local and national safety regulations.

Servicing, modification, testing and maintenance of electrical appliances should only be carried out in accordance with all appropriate legal requirements, accident prevention regulations and valid standards.

All regulations of the appropriate utility supply companies and standards relating to safety (not limited to electrical safety) are to be complied with.

Before any service work is commenced, the machine must be disconnected from the mains.

Even with the machine switched off, mains power may be applied to some components.

A general visual check should always be carried out.

2 Risk of injury due to sharp edges

There may be a risk of injury due to sharp edges.

Protective gloves should be worn and the edge protection, Mat. no. 05057680, should be used.

3 Risk of electric shock when working on frequency converter electronic unit (EFU)

PW 6055, PW 6065

Danger!

A capacitor on the frequency converter electronic unit holds an electrical charge with a potential difference of up to approx. 400 V, even after disconnection from the mains.

After disconnection from the mains a discharge resistor connected in parallel with the capacitor should discharge it within approx. 2 min.

For safety reasons before working on any of the frequency converter (EFU) components it is essential to ensure that this discharge has in fact taken place.

4 Risk of electric shock when working on power-programme module (ELP) (control-power module)

PW 5065

Danger!

A capacitor on the power-programme module (ELP) holds an electrical charge with a potential difference of up to approx. 400 V, even after disconnection from the mains.

After disconnection from the mains a discharge resistor connected in parallel with the capacitor should discharge it within approx. 2 min.

For safety reasons before working on any of the power-programme module (ELP) components it is essential to ensure that this discharge has in fact taken place.

5 Electrical connection via plug connector

It is always recommended to make electrical connection via a plug and socket so that electrical safety checks, e.g. during repair or service work, can be carried out easily.

The socket must be accessible after machine installation. This also applies even if an on-site mains switch is also already provided.

Models with a total connected load greater than 9 kW an additional on-site mains switch must also be provided.

Electrical connection must be carried out in accordance with all appropriate legal requirements, accident prevention regulations and valid standards.

6 Touch current measurement

Note

Touch current measurement should be carried out on all accessible conductive parts that are not connected to earth.

Warning!

Touch current measurement should only be carried out after the earth connection of the unit under test has been checked and found to be satisfactory!

Dangerous voltages may exist on defective machines as well as on accessible conductive parts that are not connected to earth!

Note

Touch current measurement should be carried out on the following accessible conductive parts:

- Door ring

B Modification History

When?	Who?	What?
11.05.2005	Olaf Meyer zu Drer	Initial compilation

C Technical Data

Semi-commercial machines		PW 6055 and PW 6065	PW 5065
Casing, front panel	Version	Generation 2000, spaceframe construction	
	Door lock	Electromagnetic release	
Suds container	Suds container unit	Old suds container unit (ASA/OSU)	
	Drum	Honeycomb drum	
	Drum diameter	480 mm	
	Maximum load, dry laundry	5.5 kg / 6.5 kg	6.5 kg
	Drum volume	5.5 kg: 54 l, 6.5 kg: 59 l	6.5 kg: 59 l
	Drum opening dimensions	Large door opening 300 mm	
	Heating	2 x 2.65 kW, (5.3 kW, 2 N 16 A)	2 x 2.65 kW, (5.3 kW, 2 N 16 A)
Water path	Water intake	Cold and hot water connection: Water path control unit	
		Alternative water supply valve (can be retrofitted by Service Dept.)	-
		Intake via door glass	
	Drainage	Drain valve (AV)	
		Synchronous drain pump (LP), head height 1 m	
Drive	Belt drive	Ribbed drive belt, motor spindle diameter: 27.5 mm, axis-centre difference: 345 mm, gearing (no. of motor rotations for one drum rotation): 10.6	
		Distance between axes: 345 mm	
	Electric motor	Commutator-free 3-phase asynchronous motor MXT 30	
	Speed monitoring	Tachogenerator -16-pole	
Control	Electronic frequency converter EFU 003-A	Power-programme module (ELP) (control-power module) with integrated frequency converter (FU light)	
Control technology	Control panel	Graphic display, multifunction selector	Graphic display, rotary selector
	Selection module	221 ID 922	191 ID 902
	Power-programme module	ELP 220 ID 973	ELP 250-G ID 903
		Control technology: Novotronic IV. Update feature via serial optical PC interface on module	
Wash technology	Process technology	Hydromatic IV E, stored in ELP, programme update feature available	Hydromatic IV E, stored in ELP, programme update feature available
	Level monitoring	Analog pressure sensor (ADS) integrated on the power-programme module (ELP)	
	Suds temperature sensor	NTC (R30)	
	Imbalance monitoring	Speed-imbalance recognition	
Imbalance sensor			
Payment system	Machine pre-fitted with connections for operation with payment system		
Dispensing system	Machine supplied with 4 dispenser relays for activating external dispenser pumps		Machine supplied with 1 dispenser relay for activating 1 external dispenser pump

Table 1: Semi-commercial washing machine (KG-WA), Generation 2000

D Layout of Electrical Components

PW 6055, PW 6065

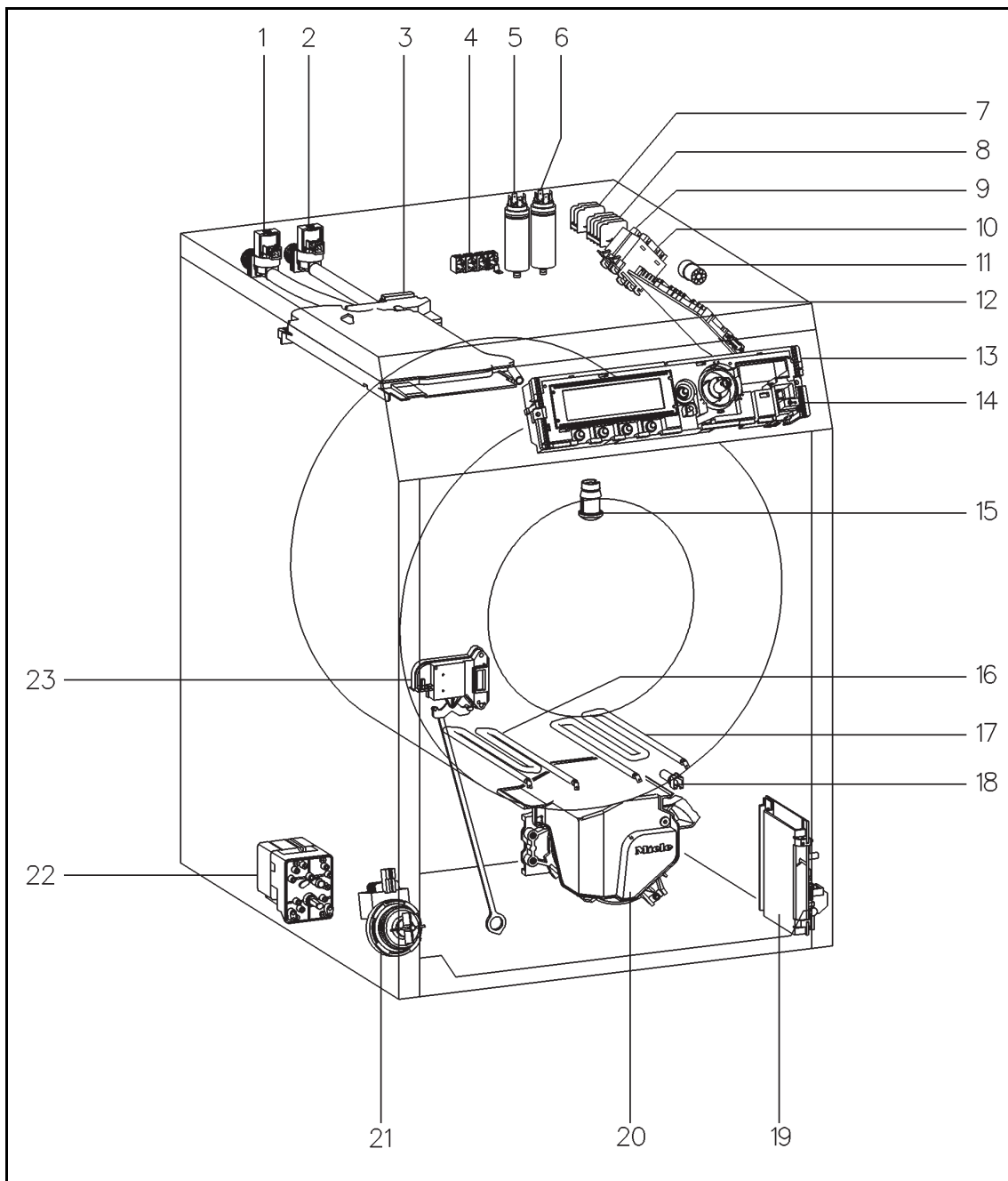

Layout 1

1 (Y12)	Solenoid valve - Hot water
2 (Y14)	Solenoid valve - Cold water
- (Y6)	Solenoid valve - Alternative water supply (can be retrofitted by Service Dept.)
3 (M24)	Motor - Water path control unit
4 (X3/1)	Mains terminal strip
5 (1Z1)	Interference suppressor
6 (2Z1)	Interference suppressor
7 (1X3/4)	Terminal strip - Dispenser system
8 (2X3/4)	Terminal strip - Dispenser system
9 (1K1/1)	Heating relay
10 (2K1/1)	Heating relay
11 (X1/1)	Payment system socket
P6	Payment system – Programme unit
P8	Payment system – Time unit
12 (1N1)	Power-programme module (ELP) (control-power module)
13 (2N1)	Selection module (EW)
14 (S4)	Switch - Door
15 (H3/6)	Light - Drum
16 (R2)	Heater element
17 (R1)	Heater element
18 (R30)	NTC temperature sensor
19 (3N1)	Frequency converter (EFU)
20 (M5)	Motor - Drum drive
21 (M8)	Drain pump (optional)
22 (Y26)	Drain valve (optional)
23 (A2)	Door lock

PW 5065

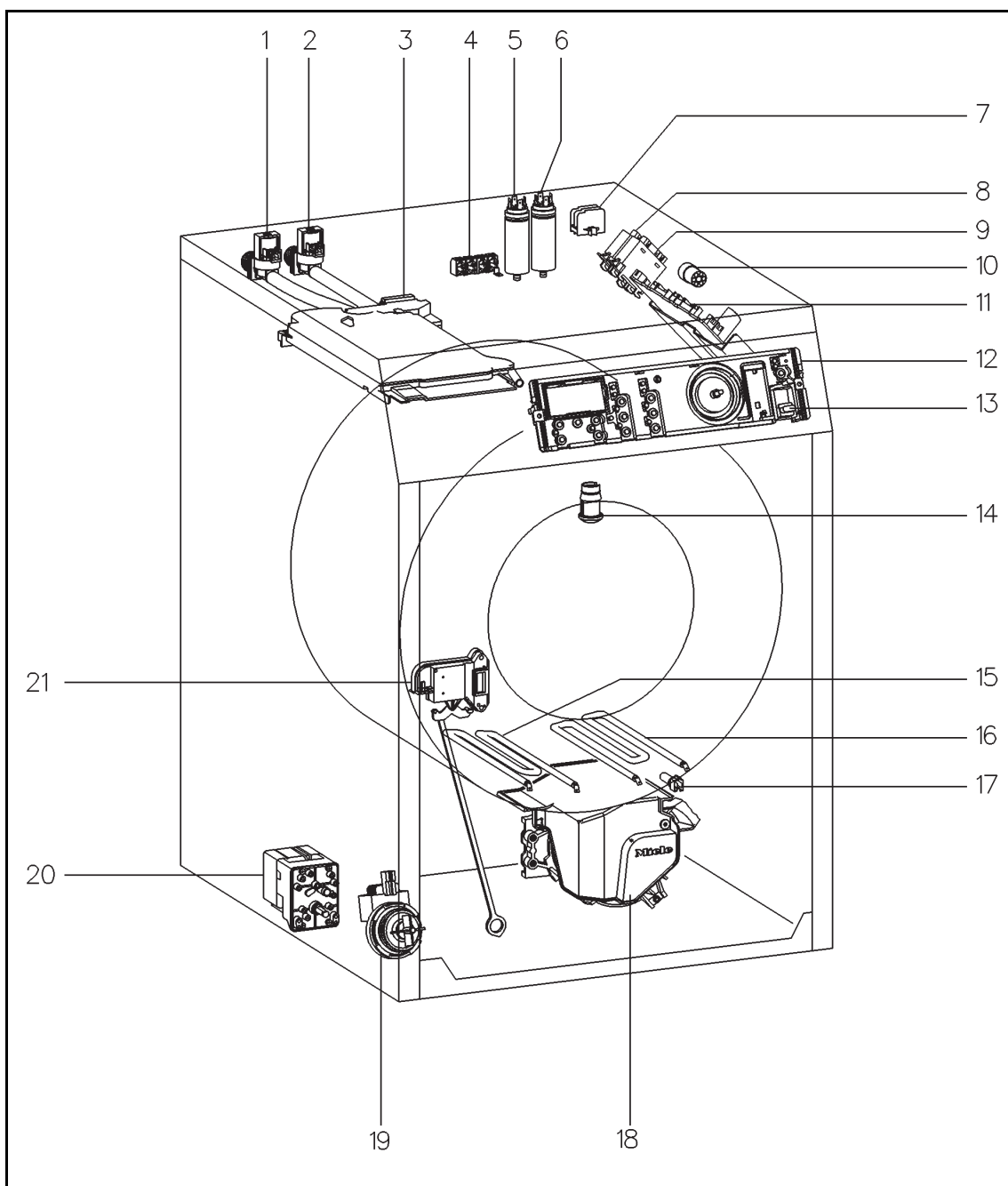

Layout 2

1 (Y12)	Solenoid valve - Hot water
2 (Y14)	Solenoid valve - Cold water
3 (M24)	Motor - Water path control unit
4 (X3/1)	Mains terminal strip
5 (1Z1)	Interference suppressor
6 (2Z1)	Interference suppressor
7 (X3/4)	Terminal strip - Dispenser system
8 (1K1/1)	Heating relay
9 (2K1/1)	Heating relay
10 (X1/1)	Payment system socket
P6	Payment system – Programme unit
P8	Payment system – Time unit
11 (1N1)	Power-programme module (ELP) (control-power module)
12 (2N1)	Selection module (EW)
13 (S4)	Switch - Door
14 (H3/6)	Light - Drum
15 (R2)	Heater element
16 (R1)	Heater element
17 (R30)	NTC temperature sensor
18 (M5)	Motor - Drum drive
19 (M8)	Drain pump (optional)
20 (Y26)	Drain valve (optional)
21 (A2)	Door lock

030 Suds container, drum, bearings, heater element

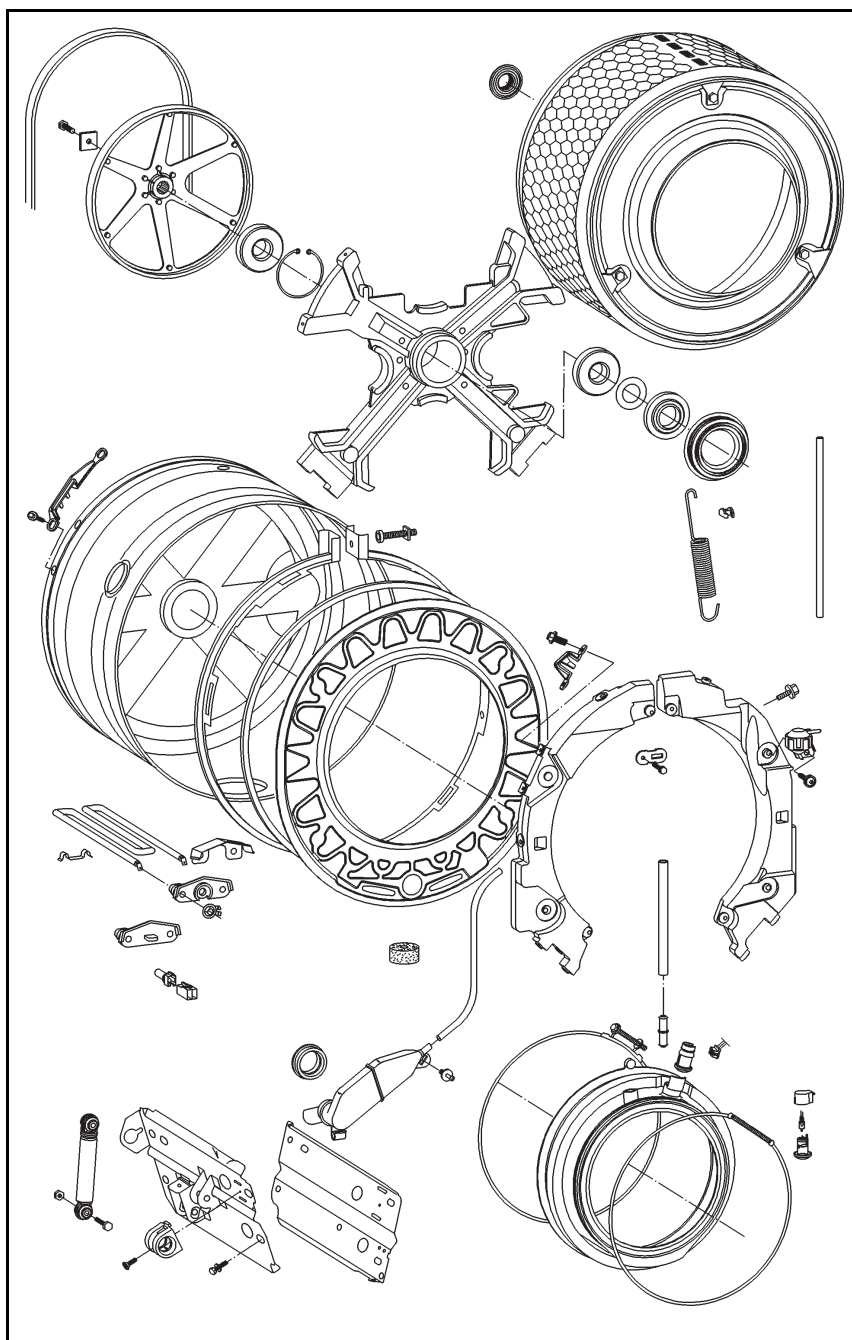

1 Technical Data

Temperature (°C)	Resistance (kΩ)
0	38.0
5	29.7
10	23.4
15	18.6
20	14.9
25	12.0
30	9.73
35	7.96
40	6.55
45	5.42
50	4.52
55	3.78
60	3.19
65	2.70
70	2.29
75	1.96
80	1.68
85	1.45
90	1.25
93	1.15
95	1.09
100	1.06

Table 1: Temperature sensor (NTC, R30) - Resistance values

2 Function

2.1 Heating

Overheating protection:

To protect the machine against overheating in case of a technical fault, e.g. if the heating relay contacts fuse together, the heater element has an overheating protection device.

If the overheating device trips, the heater element is destroyed and must be replaced.

2.2 Foam sensing

2.2.1 Excess foam when heating during the main wash

Foam is produced when the suds are heated. When the foam enters the ventilation system, the pressure in the suds container increases.

If, during heating, the analog pressure sensor registers an increase in pressure of 60 mm wc (mm water column) above washing level, the following occurs:

- The heating is switched off for 2 min. After this time, it is only switched on again when the pressure increase has dropped to 15 mm wc above washing level. The fact that the desired temperature may not have been reached is not indicated as a fault.
- If excess foam is registered 3 times, the Thermostop step is skipped.
- At the end of the programme, the display shows **Check dispensing**.
- The fault indication **F16 Excess foam** is saved, see Fault code **F16**, excess foam, 080 3.10.

2.2.2 During rinse water intake excess foam is in the drum vent or odour trap

If excess foam exists during rinsing, then during water intake the pressure in the suds container rises more rapidly than it would due merely to the incoming water.

If, during rinse water intake, the analog pressure sensor registers an increase in pressure of 40 mm wc within 4 s, the following occurs:

- The water intake is switched off for at least 15 s.
- After this time, it is only switched on again when the pressure increase has dropped to 15 mm wc.
- At the end of the programme, the display shows **Check dispensing**.
- The fault indication **F16 Excess foam** is saved, see Fault code **F16**, excess foam, 080 3.10.

2.2.3 During spinning excess foam is in the drum (water around drum circumference registered)

During spinning foam is produced and, due to centrifugal force, collects as water around the drum circumference. The pressure increases and the water acts as a brake on the drum.

If, during spinning, the analog pressure sensor registers a higher than expected pressure for the spin speed in operation or the desired/actual speed variation is greater than expected, the following occurs:

- The spin speed is reduced or the spin cycle is interrupted.
- If a spin above 700 rpm has not been carried out for a period of at least 60 s, an additional rinse is activated.
- At the end of the programme, the display shows **Check dispensing**.
- The fault indication **F16 Excess foam** is saved, see Fault code **F16**, excess foam, 080 3.10.

4 Service

4.1 NTC temperature sensor, R30

Danger!

Risk of electric shock when working on low-voltage components.

There is no circuit isolation between the power-programme module (ELP) and mains voltage.

When working on a machine connected to the mains, the possible application of mains potential to low-voltage components (e.g. NTC) must be taken into consideration.

4.2 Drum neck/suds container spacing gap setting

Note

The drum neck/suds container spacing gap must be set precisely to prevent the drum neck rubbing against the door seal during operation.

Note

Initial requirements:

- Drum, suds container, suds container cap and weights all pre-assembled.
- Pulley wheel secured on drive shaft.
- Motor bracket not secured.

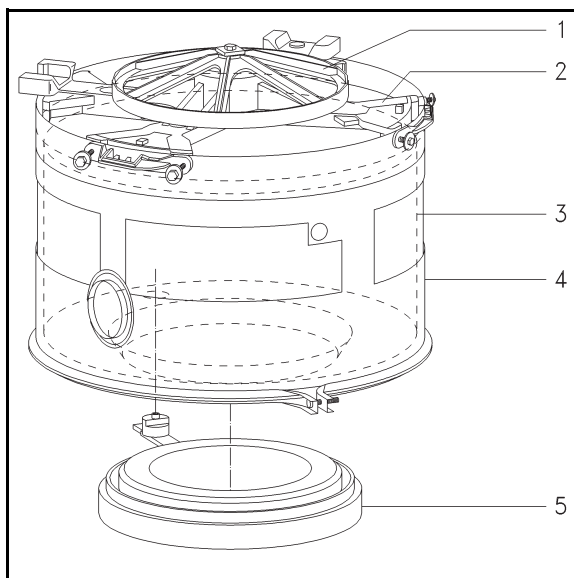
**Fig. 1**

- | | |
|---|----------------------------------|
| 1 | Pulley wheel |
| 2 | Drum bearing cross |
| 3 | Drum |
| 4 | Suds container |
| 5 | Centring tool, Mat. no. 05754630 |

- ⚙ Loosen the bearing cross fixing screws by 2 turns.
- ⚙ Fit the centring tool for drum and suds container with large door opening (300 mm) on the suds container opening.
- ⚙ Tip the complete suds container unit downwards and rest it on the centring tool.
- ⚙ Press down the suds container so its cap fully rests on the centring tool all around the circumference.
- ⚙ Press down the bearing cross so the drum opening fully rests on the centring tool all around the circumference.
- ⚙ Tighten the bearing cross fixing screws.
- ⚙ Remove the centring tool.

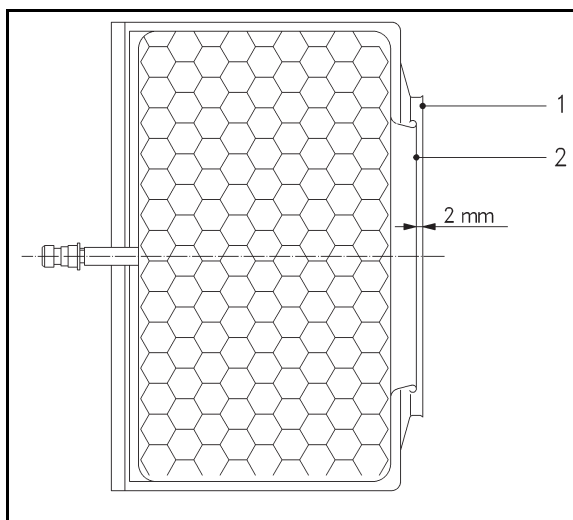
**Fig. 2**

- 1 Suds container cap
2 Drum

↗ Check the desired gap dimension: 2^{+1} mm.

2 Function

2.1 Water path control unit and motor, M24

Driven via 230 V motor. Water path control unit position established via slip contacts and time measurement.

2.2 Water intake monitoring

Water Control System (WCS):

With water intake monitoring, a closed on-site tap, water pressure that is too low or a major leak, e.g. due to a missing fluff filter, can be detected.

During water intake the pressure increase is monitored to ensure that a pressure increase of 8 mm wc occurs within **75 s**. If this is not registered, the programme is cancelled and a **Water intake** fault is indicated.

Hot water/Alternative water only: With the programmable water intake option **Hot water/Alternative water** activated, the fault is registered but the programme is continued with cold water intake only.

2.3 Water overflow monitoring

If a water level of 220 mm wc is reached, the drain pump/valve is activated until the level drops to 180 mm wc.

2.4 Alternative water

PW 6055, PW 6065

The alternative water intake is via the main wash compartment.

For retrofitting of alternative water supply valve, see Alternative water valve fitting, 040 4.1.

2.5 External dispensing

PW 6055, PW 6065

These machines are supplied pre-fitted with 4 dispenser relays for activating external dispenser pumps.

Warning!

The total current drawn by all connected dispenser pumps must not exceed 4 A.

Each dispensing relay can be used to dispense one liquid agent.

The dispensing relays are activated in accordance with the Service Dept. programmable functions set for external dispensing.

Dispensing relay		Relay 1	Relay 2	Relay 3	Relay 4
		Normal detergent	Chlorine bleach with programmes > 60 °C	Mild detergent	Fabric conditioner
Pre-wash	Cottons, Minimum iron, Table linen, Kitchen linen, Disinfection	120 s	120 s		
Main wash	Cottons, Sluice, Disinfection,	120 s	120 s		
	Cottons, Minimum iron, Quick wash, Outerwear, Shirts, Denim, Pillows, Table linen, Kitchen linen, Towels, Hygiene	120 s			
Pre- and main wash	Delicates, Silks, Woollens, Curtains			120 s	
Fabric conditioner	All programmes except Table linen				120 s

Table 1

The first and second dispensing stages are followed by a 5 s flush of water.

The hoses for liquid agents are connected to the rear of the detergent dispenser drawer.

For dispenser connection, see Dispenser unit connection, 040 4.2.

2.6 External dispensing

PW 5065

This machine is supplied with 1 dispenser relay for activating 1 external dispenser pump.

Warning!

The total current drawn by the connected dispenser pump must not exceed 4 A.

The dispensing relay is activated in accordance with the Service Dept. programmable function set for external dispensing at the start of the pre-wash/main wash.

The first and second dispensing stages are followed by a 5 s flush of water.

The hose for liquid agent is connected to the rear of the detergent dispenser drawer.

For dispenser connection, see Dispenser unit connection, 040 4.2.

4 Service

4.1 Alternative water valve fitting

PW 6055, PW 6065

✂ Remove the machine lid.

Warning!

Lay the electrical connections above the transverse strut so that they cannot be damaged by the sharp edge underneath the strut.

Warning!

The components for hot water connection are specially designed to withstand high temperatures. Therefore only these parts should be used for the hot water connection.

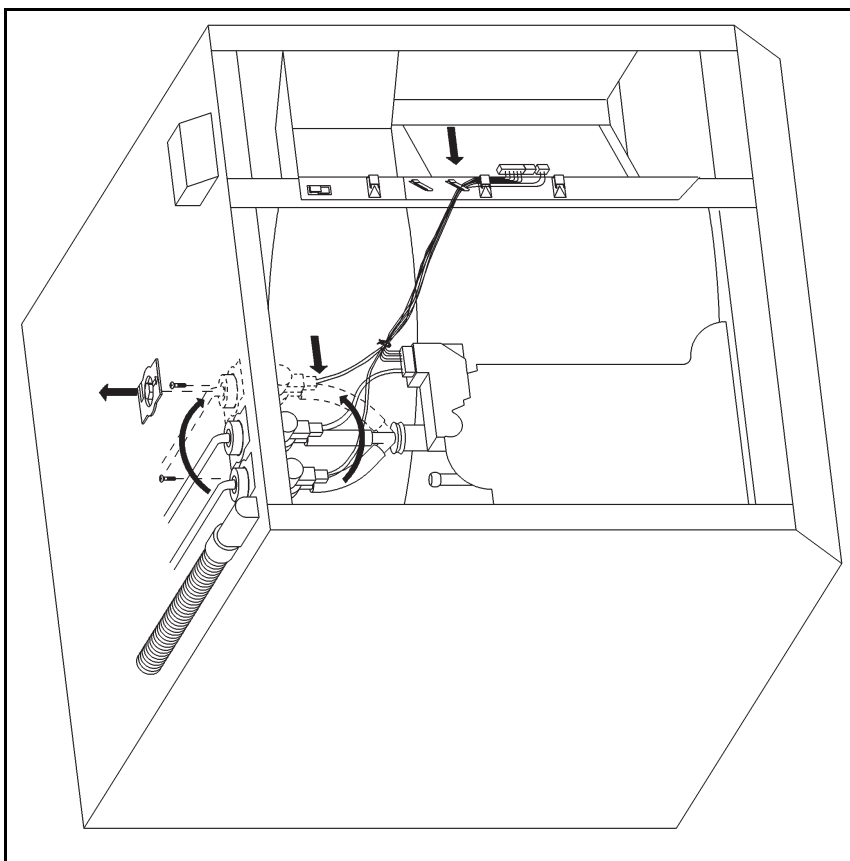
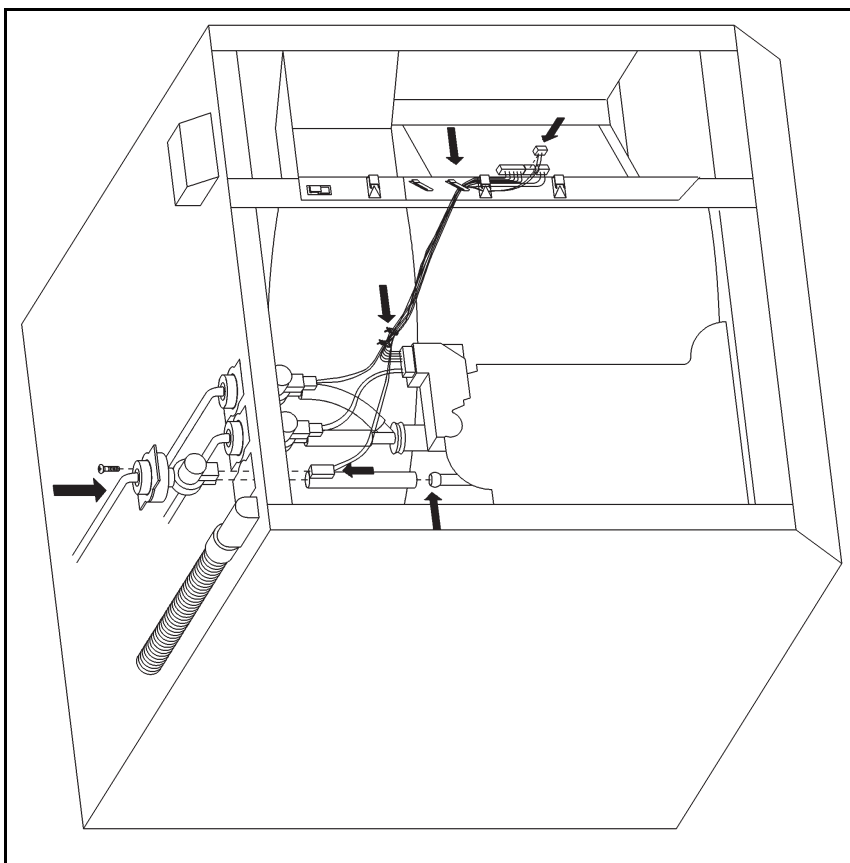

Fig. 1

Note

“Left” and “right” in the following assume the machine is being viewed from the front.

- ↯ Release the casing cover and remove it.
- ↯ Disconnect the hot water intake hose.
- ↯ Disconnect the plug connection from the hot water inlet valve (Y12).
- ↯ Unscrew the fixing screw from the hot water inlet valve (Y12).
- ↯ Transfer the hot water inlet valve (Y12) from the left to the right.
- ↯ Turn the Y-hose and refit it on the hot water inlet valve (Y12).
- ↯ Secure the hot water inlet valve (Y12) with its fixing screw.
- ↯ Reconnect the plug connection to the hot water inlet valve (Y12).
- ↯ Fit and secure the hot water intake hose on the hot water inlet valve (Y12).

**Fig. 2**

- ↯ Fit the alternative water valve (Y6). Secure it with its fixing screw.
- ↯ Connect the hose between the detergent dispenser and the alternative water valve (Y6).
- ↯ Lay the electrical connection in the small top channel from the power-programme module (ELP 1N1) to the alternative water valve (Y6). Secure it to the wiring harness with cable ties and connect both plugs.
- ↯ Refit the machine lid.

- ✎ Set the programmable function main wash water and/or rinse water to the option **Alternative water supply**.
- ✎ Fit and secure the alternative water supply hose to the alternative water valve (Y6).

4.2 Dispenser unit connection

Note

With the PW 5065 one dispenser pump with a connection hose with inner diameter, $D_i = 6$ mm and outer diameter, $D_a = 9$ mm can be connected.

With the PW 6055 and PW 6065 up to 4 dispenser pumps with hoses with $D_i = 4$ mm / $D_a = 6$ mm can be connected. For particularly viscous agents, one of the 4 pumps can be connected with a hose with $D_i = 6$ mm / $D_a = 9$ mm.

Warning!

Only the holes required for a specific application should be made in the machine casing and detergent dispenser.

- ✎ Remove the detergent dispenser.
- ✎ Remove the detergent dispenser top part.

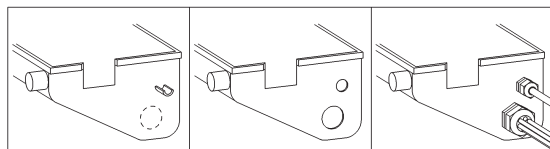

Fig. 3

- ✎ With the PW 5065 and with viscous liquid agent, remove the stub on the detergent dispenser and drill a 19 mm dia. hole in the position.
- ✎ With the PW 6055 and PW 6065, if the single connection for viscous liquid agent is not sufficient, drill out the large marked opening, diameter 28.5 - 30 mm, on the detergent dispenser.
- ✎ Secure the hose through-feed/s on the detergent dispenser.

Warning!

The hoses must not contact or otherwise interfere with the concertina hose which could otherwise be damaged.

- ✎ Lay the hose/s to the detergent dispenser and close any unused holes on the hose through-feed with stoppers. Tighten the hose through-feed nut/s.

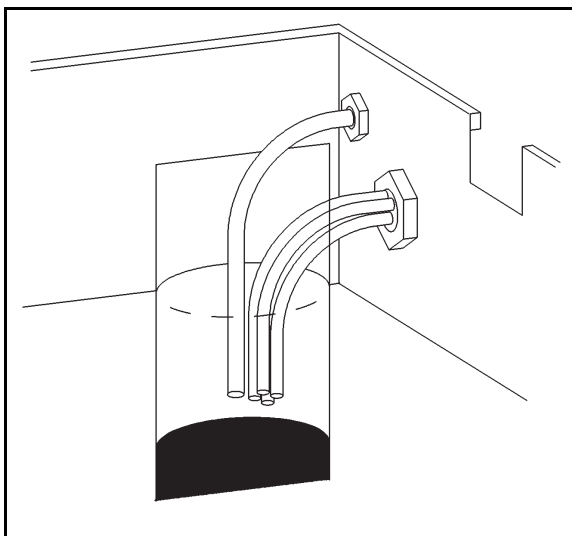
**Fig. 4**

- ✂ Refit the detergent dispenser top part.
- ✂ Refit the detergent dispenser.
- ✂ Open the pre-punched opening/s in the rear casing for the hoses and electrical connections as necessary.

Note

When opening the holes, ensure that the waste metal pieces do not fall into the machine.

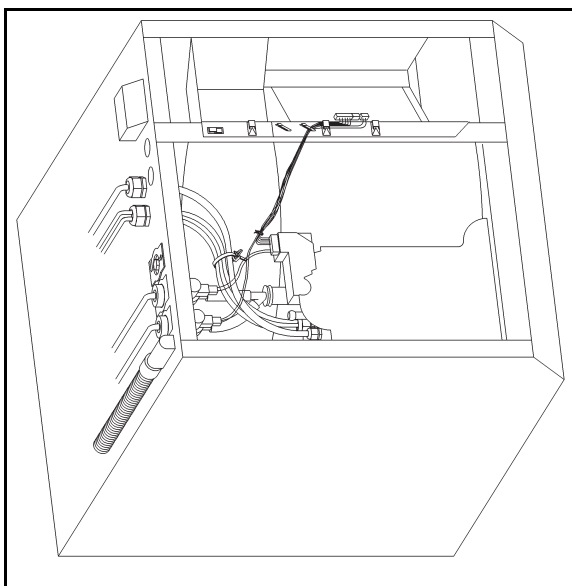
**Fig. 5: Hose positioning**

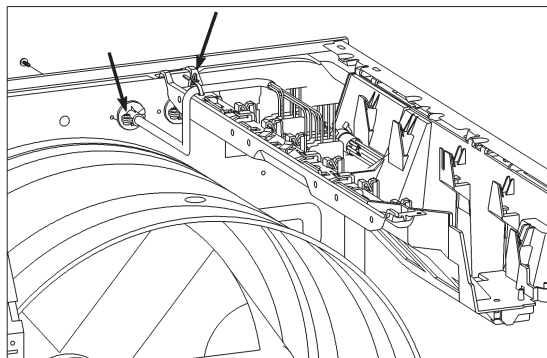
**Fig. 6:** Wiring positioning

- ✎ Fit the appropriate hose and wire through-feed parts on the rear casing.

Warning!

Take care to lay hoses and wires such that they cannot be damaged by sharp edges.

Lay the electrical connections above the transverse strut so that they cannot be damaged by the sharp edge underneath the strut.

- ✎ Secure the hose/s in the machine.
- ✎ Optional: Activate the detergent drawer opening lock.
- ✎ Lay the electrical connection between the dispenser terminal strip (1X3/4, 2X3/4) and the dispenser. Secure the wires in the machine with cable ties.
- ✎ Make the electrical connections to the dispenser unit in accordance with its documentation and the washing machine wiring diagram.

Note

PW 6055 and PW 6065 only:

The voltage supply to the dispenser via the washing machine dispensing relay can be either from the washing machine power supply (230 V) or the dispensing relay can be used as a potential-free contact.

When connecting an external dispenser to an external voltage supply:

Disconnect the L-DOS (live, phase) plug from the dispenser terminal strip (1X3/4), insulate it and tie it to the wiring harness.

Connect the plug from the common external power source to the socket on the dispenser terminal strip (1X3/4). Take care with the phase order.

The outputs from the dispenser terminal strip (2X3/4) can be used as potential-free contacts.

- ✍ PW 6055 and PW 6065: Set the external dispensing programmable option on the washing machine, see Programming mode summary, 080 4.1 and 040 2.5 External dispensing.
- ✍ PW 5065: Set the external dispensing programmable option on the washing machine, see Programming mode summary, 080 4.2 und 040 2.6 External dispensing.

050 Drainage via drain valve

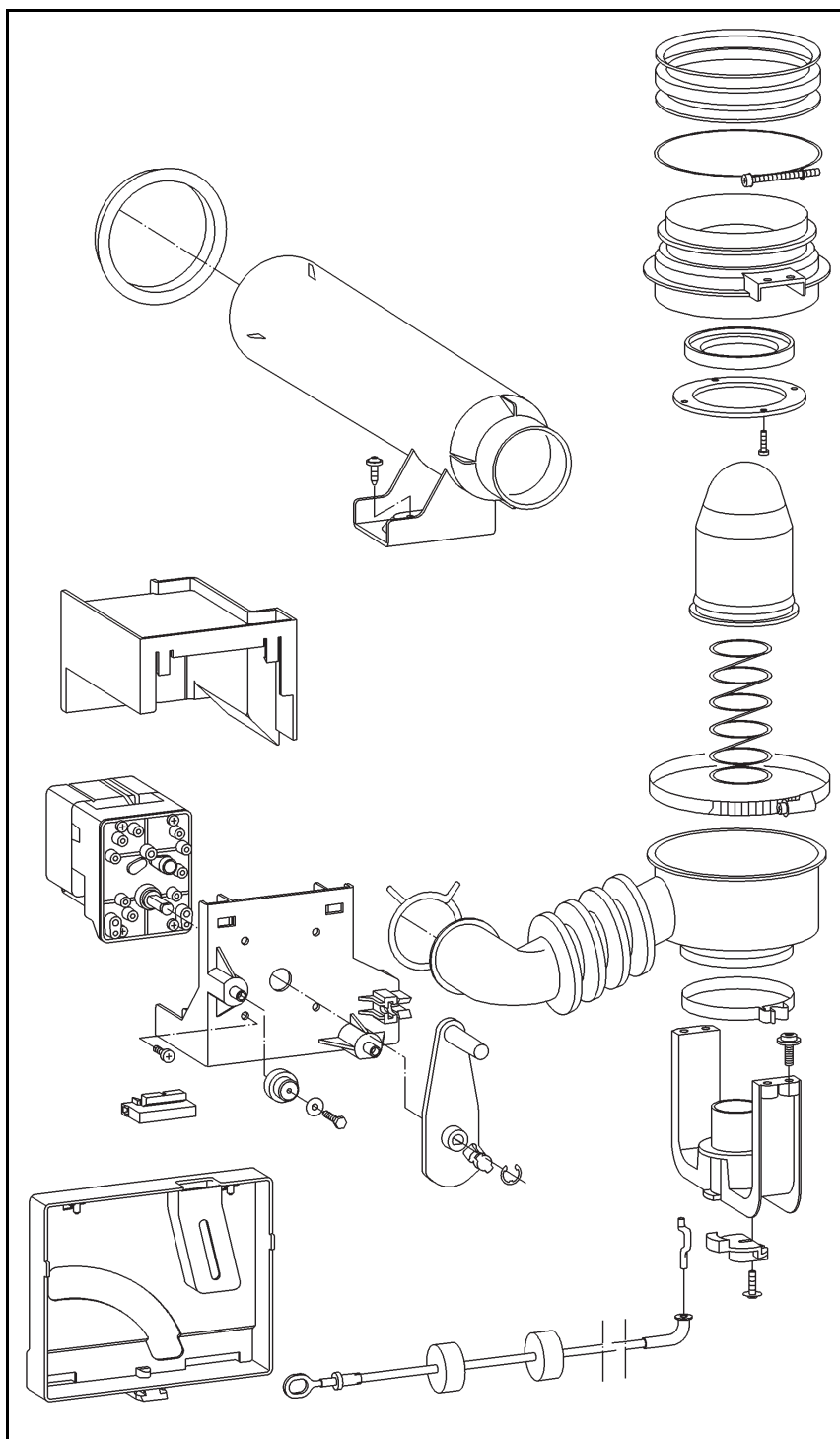

2 Function

2.1 Drainage monitoring

Drainage monitoring is as with drainage via a drain pump, see 060 2.1 Drainage monitoring.

060 Drainage via drain pump

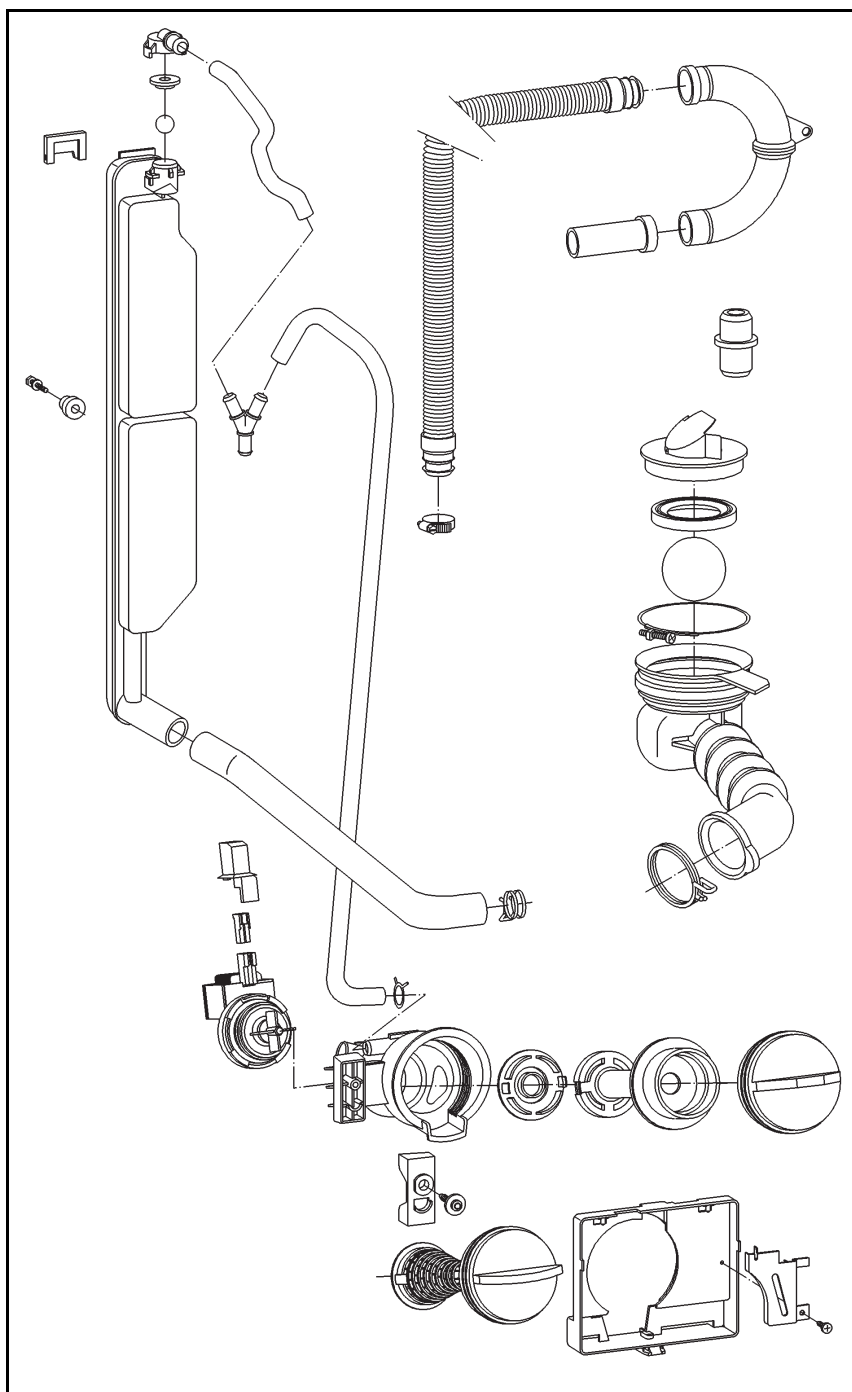

2 Function

2.1 Drainage monitoring

When the drain pump is activated, a check is made to ensure that after 150 s the water level has dropped to **7 mm wc**. If the level has not dropped sufficiently, the programme is interrupted and the fault message **Drainage fault** is indicated.

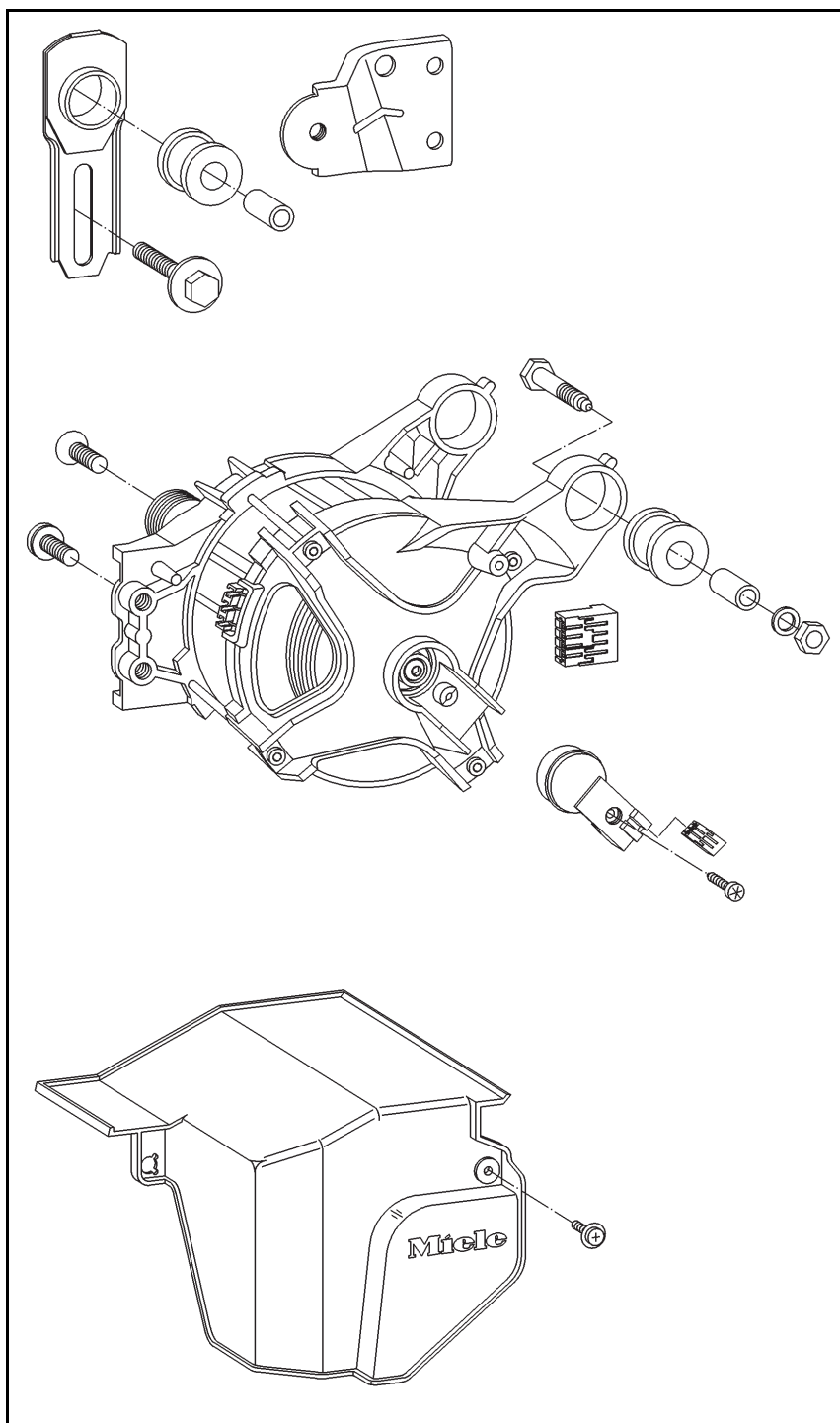
070 3-phase motor

1 Technical Data

Special tool	
Setting gauge for drive belt tensioning	Mat. no. 05997590
Drive belt fitting lever	Mat. no. 05057690

Table 1: Drive - Special tool

3 Fault Repair

3.1 Drive failure

Cause

Drive blocked.

Check drum and drive for free movement

- ↺ Turn the drum by hand.
- ↺ If the drum can be turned freely with the drive belt fitted, the drum and drive are not blocked.
- ↺ If this is not the case, carry out the following checks:
 - ↺ Remove the drive belt.
 - ↺ Check the drum for free movement.
 - ↺ Check the drive motor for free movement.

Cause

Tachogenerator defective.

Check the tachogenerator

Danger!

Risk of electric shock when working on low-voltage components.

There is no circuit isolation between the power-programme module (ELP) and mains voltage.

When working on a machine connected to the mains, the possible application of mains potential to low-voltage components must be taken into consideration.

Note

The motor plug pin allocation is shown on the wiring diagram.

The given values apply to measurements taken at room temperature (20°C).

- ↺ Turn the motor (turn the drum rapidly by hand) and measure the voltage at the tachogenerator.
- ↺ Desired value for AC voltage at tachogenerator: Approx. 1 - 3 V.

- ↯ Check the tachogenerator for short circuit with the motor earth.
- ↯ Check that the magnets are secured properly on the motor shaft.

Cause

Motor winding temperature limiter defective.

Check the motor winding temperature limiter

- ↯ Disconnect the motor connection plug.
- ↯ Check the motor winding temperature limiter for continuity.
- ↯ Check the motor winding temperature limiter insulation for short-circuit with the motor.

Cause

Motor winding defective.

Check the motor winding

- ↯ Measure the resistance of the motor windings.
- ↯ Desired resistance value for each motor winding measured at the motor plug at room temperature (20°C): $7 \Omega \pm 1 \Omega$ (with higher temperatures the resistance may be up to 1.5-times higher).
- ↯ Permitted difference between individual measurements: $< 0.5 \Omega$.
- ↯ Desired resistance between motor winding and motor earth: $\infty \Omega$ (isolation).

Cause

Motor earth open-circuited.

Check the motor earth

- ↯ Measure the resistance between the motor plug earth pin and the motor housing.
- ↯ Desired resistance figure: Zero.

Cause

Motor wiring harness defective.

Check the motor wiring harness

- ↯ Check the motor wiring harness and plug for visible signs of damage.
- ↯ To check intermittent faults, flex the wiring harness while checking between different wires for short circuits.
- ↯ To check intermittent faults, flex the wiring harness while checking individual wires for continuity.

080 Fascia panel, control module

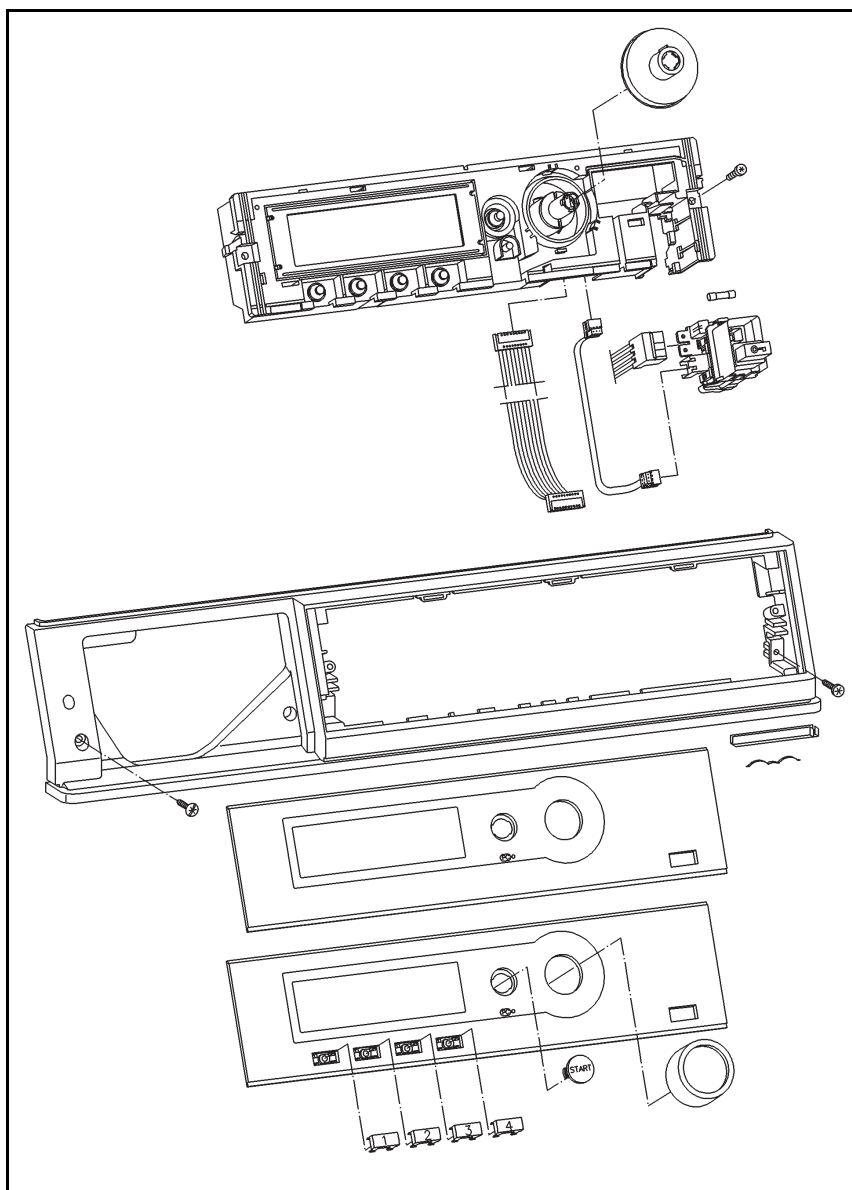

2 Function

2.1 Reset signal for payment system

At the end of a programme in order to reset an external payment system the machine provides a mains voltage signal for 5 s applied to the payment system connection socket (X1/1), pin 7 (payment system contact).

During this time, it is not possible to open the door via the door switch (S4).

The reset signal is also provided under the following circumstances:

- Free programmes
- Programme interruption
- Technical fault

2.2 Time of day programmable function

This function is for the display.

2.3 Free spin programmable function

This programmable function is used to set whether the **Spin** programme is provided free or at a charge.

The **Drain** programme is always free.

PW 6055 and PW 6065: Programming mode, see Programming mode summary, 080 4.1.

PW 5065: Programming mode, see Programming mode summary, 080 4.2.

2.4 Language programmable function

PW 6055, PW 6065

International:

Multilingual start screen, e.g. for multilingual countries and camp sites.

The desired language is selected before the basic programme menu and is applicable for only one programme.

The **Sort language** programmable function is available to select and sort four favourite languages for international installations.

2.5 Payment system programmable function

This is used to set the type of payment system. The appropriate operating procedure is shown in the display.

For payment system details see 090 2.2 Payment system.

PW 6055 and PW 6065 only: For central control via RS 232 interface see 090 2.3 Central control via RS 232 interface with 9-pole plug.

2.6 Operator code programmable function

Option code not required (domestic use):

Domestic programmable functions are freely available.

Supervisor programmable functions are not accessible.

Option code required (supervisor):

Access to domestic and supervisor programmable functions via code entry.

The code is freely selectable. If the code is no longer known to the supervisor, then it can be reset to **000** by resetting all programmable functions to the standard settings.

2.7 Max. speed programmable function

PW 6055, PW 6065

This is used to set the maximum spin speed (1400 - 1600 rpm) for the **Cottons** and **Spin** programmes.

2.8 Imbalance level programmable function

PW 6055, PW 6065

This is used to set the imbalance levels.

2.9 Heater rating programmable function

The heater rating P_{Hz} is required for the calculation of controlled energy consumption.

2.10 Heating programmable function

With this programmable function the heating can be switched off if the machine is being used as a hot water model.

Thermostop stages are then skipped

Heating will still take place in programmes which do not use the hot water intake such as **Wollens**, **Silks**, **Curtains** and **Proofing**.

2.11 Temperature reduction programmable function

PW 6055, PW 6065

This is used to reduce the maximum suds temperature to 80 °C with high-altitude locations > 4000 m above sea level to prevent the suds boiling.

2.12 Control programmable function

PW 6055, PW 6065

For setting the type of control with or without direct selection buttons and country-specific additional programmes.

2.13 Drum lighting programmable function

On models without drum lighting, the lighting function must be deactivated.

2.14 Standard settings programmable function

To reset all programmable functions to standard settings.

The code no. for accessing the supervisor level will be reset to **000**.

3 Fault Repair

3.1 Demonstration mode

Symptom

No programme start, service and programming modes cannot be accessed.

Cause

The demonstration mode is active.

Remedy

- ↯ PW 6055 and PW 6065: Demonstration mode deactivation, see Demonstration mode activation / deactivation, 080 4.3.
- ↯ PW 5065: Demonstration mode deactivation, see Demonstration mode activation / deactivation, 080 4.4.

3.2 Fault indication: Lamp defective

Symptom

In normal operation mode the display shows **Lamp defective**.

Cause

Halogen bulb open-circuited (bulb defective).

The power-programme module (ELP) has registered an open circuit in the drum lighting circuit.

The fault is not saved.

Remedy

- ↯ Check the halogen bulb and exchange it if necessary.
- ↯ Check the drum lighting circuit for continuity.

Cause

Halogen bulb short-circuited.

The power-programme module (ELP) has registered a short circuit in the drum lighting circuit.

Remedy

- ↯ Check the halogen bulb and exchange it if necessary.
- ↯ Check the drum lighting circuit for short circuit.

3.3 Fault indication: Technical fault**Symptom**

In normal operation mode the display shows **Technical fault**.

Fault code display.

The programme is interrupted, water intake is shut off and the drain pump operates or the drain valve opens for 120 s.

Cause

The power-programme module (ELP) or selection module (EW) has registered a technical fault.

The power-programme module (ELP) interrupts the programme.

The fault indicated is the reason for the programme interruption.

Remedy

- ↯ PW 6055 and PW 6065: Fault memory display, see Service mode summary, 080 4.5.
- ↯ PW 5065: Fault memory display, see Service mode summary, 080 4.6.
- ↯ Check the Mat. nos. to ensure that the correct power-programme module (ELP) and selection module (EW) are fitted.
- ↯ Check the electrical connections between the power-programme module (ELP) and selection module (EW).

3.4 F 0, no fault

Cause

No fault saved in the power-programme module (ELP) fault memory.

Remedy

✎ None required.

3.5 Fault code F 1, water/heating NTC sensor short-circuited

Symptom

In normal operation mode this fault is not indicated via the display.

The heating is switched off after approx. 10 s.

The programme continues without heating.

Hot water operation: The programme continues with cold water.

Cause

NTC temperature sensor (R30) or its connections short-circuited.

NTC temperature sensor (R30) check

- ✎ Check the NTC temperature sensor in the service mode.
- ✎ PW 6055 and PW 6065: Service mode, see Service mode summary, 080 4.5.
- ✎ PW 5065: Service mode, see Service mode summary, 080 4.6.
- ✎ Check the NTC temperature sensor and its connections for an open or short circuit, and correct insulation.
- ✎ Check the NTC temperature sensor resistance, see 030 Table 1.

3.6 Fault code F 2, water/heating NTC sensor

Symptom

In normal operation mode this fault is not indicated via the display.

The heating is switched off after approx. 10 s.

The programme continues without heating.

Hot water operation: The programme continues with cold water.

Cause

NTC temperature sensor (R30) or its connections open-circuited.

NTC temperature sensor (R30) check

- ↯ Check the NTC temperature sensor in the service mode.
- ↯ PW 6055 and PW 6065: Service mode, see Service mode summary, 080 4.5.
- ↯ PW 5065: Service mode, see Service mode summary, 080 4.6.
- ↯ Check the NTC temperature sensor for an open or short circuit, and correct insulation.
- ↯ Check the NTC temperature sensor resistance, see 030 Table 1.

3.7 Fault code F10, cold water intake

Symptom

In normal operation mode the display shows **Water intake fault**.

The programme is interrupted, water intake is shut off and the drain pump operates or the drain valve opens for 120 s.

The water intake is monitored, see 040 2.2 Water intake monitoring.

Cause

The machine has a leak. The Water Control System (WCS) has closed the water intake.

Remedy

- ↯ Close the on-site stopcock.
- ↯ Locate the leak and repair it.

Cause

On-site stopcock is closed.

Remedy

↻ Open the on-site stopcock.

Cause

Water intake filters clogged.

Remedy

↻ Clean the water intake filters.

Cause

Low on-site water pressure.

On-site water pressure check

- ↻ The flow pressure must be at least 1 bar (100 hPa). With the stopcock fully open, at least 5 l water should flow from the tap within 15 s.
- ↻ If the on-site flow pressure is less than 1 bar, then it should be increased.
- ↻ If the on-site flow pressure cannot be increased, then low water pressure can be programmed as an option (water intake extended).
- ↻ PW 6055 and PW 6065: Programming mode, see Programming mode summary, 080 4.1.
- ↻ PW 5065: Programming mode, see Programming mode summary, 080 4.2.

Cause

Water inlet solenoid valve defective.

Remedy

↻ Check the water inlet solenoid valve.

3.8 Fault code F11, water drainage

Symptom

In normal operation mode the display shows **Water drainage fault**.

The programme is interrupted and the drain pump operates or the drain valve opens for 120 s.

The water drainage is monitored, see 060 2.1 Drainage monitoring.

Cause

Drain pump version: Insufficient drainage.

Remedy

- ↯ Check fluff filter for blockages caused by foreign bodies.
- ↯ Check drain hose.
- ↯ Check non-return valve.
- ↯ Check drain pump venting and priming.
- ↯ Check drain pump for correct operation.

Cause

Drain valve version: Insufficient drainage.

Remedy

- ↯ Check drain valve for correct operation.

3.9 Fault code F15, hot water intake

PW 6055, PW 6065

Symptom

In normal operation mode this fault is not indicated via the display.

The programme continues with cold water.

The water intake is monitored, see 040 2.2 Water intake monitoring.

Cause

Hot water stopcock closed.

Remedy

↺ Open hot water stopcock.

Cause

Hot water intake filters clogged.

Remedy

↺ Clean the hot water intake filters.

Cause

Low on-site hot water pressure.

On-site hot water pressure check

- ↺ The flow pressure must be at least 1 bar (100 hPa). With the stopcock fully open, at least 5 l water should flow from the tap within 15 s.
- ↺ If the on-site flow pressure is less than 1 bar, then it should be increased.
- ↺ If the on-site flow pressure cannot be increased, then low water pressure can be programmed as an option (water intake extended).
- ↺ PW 6055 and PW 6065: Programming mode, see Programming mode summary, 080 4.1.
- ↺ PW 5065: Programming mode, see Programming mode summary, 080 4.2.

Cause

Hot water inlet solenoid valve defective.

Remedy

↯ Check the hot water inlet solenoid valve.

3.10 Fault code F16, excess foam**Symptom**

In normal operation mode at the end of the programme the display shows the warning **Excess detergent**.

The water intake solenoid valve is switched off for certain periods of time.

The heating is switched off. Even though the desired temperature is not reached, this fault is not indicated.

The Thermostop step is skipped.

The spin speed is reduced or the spin cycle is interrupted.

An additional rinse cycle is carried out.

For details of foam sensing, see 030 2.2 Foam sensing.

Cause

Excess foam due to too much detergent being dispensed.

Follow detergent manufacturer's recommendations

↯ Follow the detergent manufacturer's recommendations with regard to water hardness and level of soiling.

Cause

Vent hose blocked resulting in higher pressure increase during water intake.

Remedy

↯ Clean vent hose.

Cause

Drainage fault.

Remedy

↯ Check drain pump / drain valve.

3.11 Fault code F20, heating

Symptom

In normal operation mode this fault is not indicated via the display.

Poor wash results.

The suds are not warmed.

Long programme times.

Cause

The selected temperature has not been reached before the Thermostop time has elapsed.

The heating is defective.

Check the heating

↗ Check the heater element circuit for an open or short circuit, and correct insulation.

3.12 Fault code F41, faulty EEPROM / data fault

Symptom

In normal operation mode the display shows **Technical fault**.

The solenoid valve is closed and the programme interrupted. The drain pump is activated for 120 s.

Cause

Faulty EEPROM / data fault.

Remedy

↗ Exchange the power-programme module (ELP).

3.13 Fault code F43, model type not programmed

PW 6055, PW 6065

Symptom

In normal operation mode the display shows **Technical fault**.

Cause

The selection module (EW) and power-programme module (ELP) do not match.

Remedy

- ✍ Check the Mat. nos. to verify that the correct selection module (EW) and power-programme module (ELP) are fitted.

3.14 Fault code F44, I²C bus connection faulty

PW 5065

Symptom

In normal operation mode the display shows **Technical fault**.

The solenoid valve is closed and the programme interrupted. The drain pump is activated for 120 s.

Cause

Internal technical fault in the power-programme module (ELP).

Remedy

- ✍ Exchange the power-programme module (ELP).

3.15 Fault code F45, faulty flash RAM / incorrect data

PW 6055, PW 6065

Cause

Internal technical fault in the power-programme module (ELP).

Remedy

- ↯ Check the Mat. nos. to verify that the correct selection module (EW) and power-programme module (ELP) are fitted.
- ↯ Use the reset programmable function to reset all standard settings. Then reprogram all required programmable functions.
- ↯ Exchange the power-programme module (ELP).

3.16 Fault code F46, display fault

PW 6055, PW 6065

Cause

Internal display fault in the selection module (EW). LCD module display driver defective.

Remedy

- ↯ Exchange the selection module (EW).

3.17 Fault code F47, selection module (EW) – Power-programme module (ELP) interface fault**Cause**

Selection module (EW) – Power-programme module (ELP) interface fault.

Remedy

- ↯ Check the electrical connection between the selection module (EW) and power-programme module (ELP).

3.18 Fault code F50, drive fault

Symptom

In normal operation mode the display shows **Technical fault**.

No drive.

The solenoid valve is closed and the programme interrupted. The drain pump is activated for 120 s.

Cause

Motor defective which causes the frequency converter to be defective.

Remedy

↯ Check the motor, see Drive failure, 070 3.1.

Cause

Frequency converter (FU) defective.

Remedy

↯ Exchange the frequency converter (FU).

3.19 Fault code F51, pressure sensor

Symptom

In normal operation mode the display shows **Technical fault**.

The solenoid valve is closed and the programme interrupted. The drain pump is activated for 120 s.

Cause

Analog pressure sensor (ADS) fault.

Note

The pressure sensor is integrated in the power-programme module (ELP).

Remedy

↯ Check the pressure sensor in the service mode, see Service mode summary, 080 4.5.

3.20 Fault code F53, tachogenerator

Symptom

In normal operation mode the display shows **Technical fault**.

The drum or drive is blocked. The motor does not start or is switched off after 1.5 s.

An attempt is made to start the motor during two reversing phases.

In the spin cycle, the programme is interrupted immediately.

The drive may possibly function again after a cooling period.

The solenoid valve is closed and the programme interrupted. The drain pump is activated for 120 s.

Cause

Tachogenerator defective.

The tachogenerator is not supplying any meaningful AC voltage to the power-programme module (ELP).

Check tachogenerator

↯ Check the tachogenerator, see Drive failure, 070 3.1.

Cause

Drive defective.

Via the tachogenerator the power-programme module (ELP) has registered a major discrepancy between the desired drive speed and actual drive speed.

Remedy

↯ Check the drive, see Drive failure, 070 3.1.

3.21 Fault code F56, no spin

PW 6055, PW 6065

Symptom

Final spin speed < 400 rpm even though the desired speed is at least 450 rpm.

Fault registered via tachogenerator.

Cause

Final spin speed < 400 rpm even though the desired speed is at least 450 rpm.

Remedy

- ↯ Check dispensed quantities, see Fault code **F16**, excess foam, 080 3.10.
- ↯ Check the drive, see Drive failure, 070 3.1.

3.22 Fault code F63, water path control unit

Symptom

In normal operation mode the display shows **Technical fault**.

The solenoid valve is closed and the programme interrupted. The drain pump is activated for 120 s.

Cause

Water path control system faulty.

The power-programme module (ELP) cannot register a valid position of the water path control unit within approx. 80 s of it being switched on.

Note

Water intake monitoring is not active if a valid position of the water path control unit cannot be registered.

Check the water path control system

- ↯ Check the water path control system circuit for an open or short circuit, and correct insulation.

3.23 Fault code F65, drum lighting cap missing

Symptom

In normal operation mode the display shows **Drum lighting**.

The solenoid valve is closed and the programme interrupted. The drain pump is activated for 120 s.

Cause

If no drum lighting is fitted, the drum lighting programmable function has been set in error.

Set drum lighting programmable function to off.

- ↺ PW 6055 and PW 6065: Programming mode, see Programming mode summary, 080 4.1.
- ↺ PW 5065: Programming mode, see Programming mode summary, 080 4.2.

Cause

The lamp cover is missing or incorrectly fitted.

The power-programme module (ELP) registers a closed drum lighting unit switch (H 3/6).

Check the drum lighting unit

- ↺ Check that the cap of the drum lighting unit (H 3/6) is seated correctly.
- ↺ Check the drum lighting unit circuit (switch), see the wiring diagram.

4 Service

4.1 Programming mode summary

PW 6055, PW 6065

Initial requirements

- ✍ Finish or cancel any programme in operation, including the demonstration mode.
- ✍ Open the door.
- ✍ Disconnect the suds temperature sensor (R30) plug from the power-programme module (ELP).

Note

When the suds temperature sensor (R30) plug is disconnected, the door cannot be opened via the door switch (S4).

- ✍ If the international multilingual start screen is shown, select the desired language.

Accessing

Note

After it is begun, the accessing procedure must be completed within 10 s.

- ✍ Press and hold the **Start** button.
- ✍ Close the door.
- ✍ As soon as the **Start** button flashes, release the **Start** button.
- ✍ Immediately press and release the **Start** button **5 times** and at the **5th time hold it pressed in** until programmable functions are shown in the display.

Acknowledgement indicator

Successful accessing of the programming mode is indicated by rapid flashing (5 Hz) of the **Start** button.

The display shows the Service Dept. programmable functions.

If the accessing procedure has been unsuccessful, the control automatically reverts to the normal operating mode.

Options

The set option is indicated by a **V** next to it.

- ✎ **Programmable function selection:** Turn the multifunction selector switch to **mark** the desired function and press the multifunction selector switch to **confirm** the selection.
- ✎ **Option selection:** Turn the multifunction selector switch to **mark** the desired option and press the multifunction selector switch to **confirm** the selection.

Note

Highlighted options are standard settings.

If an electronic module is supplied as a replacement part, the highlighted options should be set to suit the machine in which the module is fitted!

Programmable function	Option
Language	Language for operating, programming and service modes
Sort language	To select and sort four favourite languages for international installations
Water plus	Raised water level in pre- and main wash
	Additional rinse cycle in Cottons and Minimum iron
	Raised water level in pre- and main wash and additional rinse cycle in Cottons and Minimum iron
Suds cooling (reactivation)	Off
	On: Cold water added at end of main wash for 40 s via main wash compartment in programmes with temperatures from 70 °C
Time of day see 080 2.2 Time of day programmable function	24 h clock
	12 h clock am/pm
	No clock, 24 h Delay start
Supervisor level	Code modification
Display contrast	Standard contrast setting: Bar diagram level 4
Display brightness	Standard brightness setting: Bar diagram level 5
Stand-by	On: Display und backlight switched off automatically after 10 min
	Not in programme in operation: Stand-by only before and after programme but not while it is in operation
Memory	Off: Not active
	On: Active
Temperature	Celsius [°C]
	Fahrenheit [°F]
Language at start of accessing, see 080 2.4 Language programmable function	National
	International, additional welcome menu (favourite languages)
Intensive water plus	Off: Extras not available with setting: As on domestic machines
	On: Extras available with setting: As on domestic machines
Save	Off: Save option not available
	On: Save option available. Favourite programmes can be allocated to direct selection buttons.
Automatic load control	Off: Programme sequence is carried out assuming a full load is in the machine
	On: Active

Programmable function	Option
Water intake - Pre-wash	Cold
	Hot with temperature selection $\geq 30^{\circ}\text{C}$
Water intake - Main wash	Cold
	Hot with temperature selection $\geq 30^{\circ}\text{C}$
	Alternative water supply
Water intake - Rinses	Cold
	Hot, no cool down
	Alternative water supply
Level - Cottons	Block parameter
	+ 15 mm wc
	+ 25 mm wc
	+ 35 mm wc
Level - Minimum iron	Block parameter
	+ 10 mm wc
	+ 20 mm wc
	+ 30 mm wc
Temperature - Pre-wash - Cottons	Block parameter
	35°C
	45°C
	55°C
Wash time - Pre-wash	Block parameter
	+ 6 min
	+ 9 min
	+ 12 min
Wash time - Cottons	Block parameter
	+ 10 min
	+ 20 min
	+ 30 min
	+ 40 min
Wash time - Minimum iron	Block parameter
	+ 5 min
	+ 10 min
	+ 15 min
	+ 20 min
No. of programmes	0 additional programmes
	4 additional programmes (Kitchen linen, Table linen, Curtains, Pillows)
	2 additional programmes (Outerwear, Proofing)
	6 additional programmes (Kitchen linen, Table linen, Curtains, Pillows, Outerwear, Proofing)
Hygiene	Off: Hygiene programme not available with setting: As on domestic machines
	On: Hygiene programme available with setting: As on domestic machines
Sluice	Off: Without Sluice programmes
	On: Both Sluice programmes available
Disinfection	0 additional programmes
	4 additional programmes
Pre-wash - Cottons	Menu selection
	Permanent

Programmable function	Option
2nd pre-wash - Kitchen linen	Off
	On: Additional pre-wash in Kitchen linen
Controlled energy consumption	Off
	On: In Cottons and Minimum iron
Rinses - Cottons	Rinses 1 + 5
	Rinses 1 + 2 + 5
	Rinses 1 + 2 + 3 + 5
	Rinses 1 + 2 + 3 + 4 + 5
Rinses - Minimum iron	Rinses 1 + 4
	Rinses 1 + 2 + 4
	Rinses 1 + 2 + 3 + 4
Pre-rinse - Cottons	Off
	On
Pre-rinse - Minimum iron	Off
	On
Free spin , see 080 2.3 Free spin programmable function	Off
	On
External dispensing see 040 2.5 External dispensing	Off
	Pre-wash
	Main wash
	Pre-wash, main wash
No detergent	Off
	On: An option to deactivate the dispensing relay is available with the extras
Payment system operation , see 080 2.5 Payment system programmable function	Off (Delay start possible)
	Programme operation
	Timed operation
	IK 6
	RS 232 interface active
Supervisor level code , see 080 2.6 Operator code programmable function	Code not required. Domestic programmable functions can be modified.
	Code required. After code entry, domestic and supervisor programmable functions can be modified.
Max. spin speed , see 080 2.7 Max. speed programmable function	1600 rpm
	1500 rpm
	1400 rpm
Imbalance table , see 080 2.8 Imbalance level programmable function	5.5 kg
	6.5 kg
Heater rating , see 080 2.9 Heater rating programmable function	2100 W
	4200 W
	2650 W
	3000 W
	4600 W
	5300 W
Heating , see 080 2.10 Heating programmable function	Off: No heating, no Thermostop
	On: Heating active, Thermostop active
Temperature reduction , see 080 2.11 Temperature reduction programmable function	Off
	On: Desired suds temperature $\geq 85^{\circ}\text{C}$ limited to 80°C

Programmable function	Option
Control type , see 080 2.12 Control programmable function	D As on domestic machines
	CH As on domestic machines
	GB Launderette
	D Launderette
Drum lighting , see 080 2.13 Drum lighting programmable function	Passive: If a washing machine is without drum lighting, the drum lighting function must be deactivated.
	Active
Standard setting	Reset all programmable functions to standard settings

Table 1: Programming mode summary

Save and quit

Note

Confirmed programmable options are saved.

- ✎ Reconnect the suds temperature sensor (R30) plug to the power-programme module (ELP).

4.2 Programming mode summary

PW 5065

Initial requirements

- ✎ Finish or cancel any programme in operation, including the demonstration mode.
- ✎ Open the door.
- ✎ Disconnect the suds temperature sensor (R30) plug from the power-programme module (ELP).

Note

When the suds temperature sensor (R30) plug is disconnected, the door cannot be opened via the door switch (S4).

- ✎ During initial commissioning only: Select the desired language.

Accessing

Note

After it is begun, the accessing procedure must be completed within 10 s.

- ✎ Press and hold the **Start** button.
- ✎ Close the door.
- ✎ As soon as the **Start** LED flashes, release the **Start** button.
- ✎ Immediately press and release the **Start** button **5 times** and at the **5th time hold it pressed in** until the **Start** LED flashes.

Acknowledgement indicator

Successful accessing of the programming mode is indicated by rapid flashing (5 Hz) of the **Start** LED.

The display shows the Service Dept. programmable functions.

If the accessing procedure has been unsuccessful, the control automatically reverts to the normal operating mode.

Options

- ✎ **Programmable function selection:** Press the + / - buttons as appropriate to **mark** the desired function and press the **OK** button to **confirm** the selection.

The set option is indicated by a **V** next to it.

- ✎ **Option selection:** Press the + / - buttons as appropriate to **mark** the desired option and press the **OK** button to **confirm** the selection.

Note

Highlighted options are standard settings.

If an electronic module is supplied as a replacement part, the highlighted options should be set to suit the machine in which the module is fitted!

Programmable function	Option
Language	Language for operating, programming and service modes
Suds cooling (reactivation)	Off On: Cold water added at end of main wash for 40 s via main wash compartment in programmes with temperatures from 70 °C
Time of day, see 080 2.2 Time of day programmable function	24 h clock 12 h clock am/pm No clock, 24 h Delay start
Supervisor level	Code modification
Display contrast	Standard contrast setting: Bar diagram level 4
Display brightness	Standard brightness setting: Bar diagram level 5
Stand-by	On: Display und backlight switched off automatically after 10 min Not in programme in operation: Stand-by only before and after programme but not while it is in operation
Memory	Off: Not active On: Active
Automatic load control	Off: Programme sequence is carried out assuming a full load is in the machine On: Active
Water intake - Pre-wash	Cold Hot with temperature selection $\geq 30\text{ }^{\circ}\text{C}$
Water intake - Main wash	Cold Hot with temperature selection $\geq 30\text{ }^{\circ}\text{C}$
Water intake - Rinses	Cold Hot, no cool down
Level - Cottons	Block parameter + 15 mm wc + 25 mm wc + 35 mm wc
Level - Minimum iron	Block parameter + 10 mm wc + 20 mm wc + 30 mm wc
Temperature - Pre-wash - Cottons	Block parameter 35 °C 45 °C 55 °C
Wash time - Pre-wash	Block parameter + 6 min + 9 min + 12 min
Wash time - Cottons	Block parameter + 10 min + 20 min + 30 min + 40 min

Programmable function	Option
Wash time - Minimum iron	Block parameter
	+ 5 min
	+ 10 min
	+ 15 min
	+ 20 min
Pre-wash - Cottons	Menu selection
	Permanent
List of special programmes	Standard setting 1
	Standard setting 2
	Bakers
	Butchers
	Hairdressers
	Disinfection
Rinses - Cottons	Rinses 1 + 5
	Rinses 1 + 2 + 5
	Rinses 1 + 2 + 3 + 5
	Rinses 1 + 2 + 3 + 4 + 5
Rinses - Minimum iron	Rinses 1 + 4
	Rinses 1 + 2 + 4
	Rinses 1 + 2 + 3 + 4
Pre-rinse - Cottons	Off
	On
Pre-rinse - Minimum iron	Off
	On
Free spin , see 080 2.3 Free spin programmable function	Off
	On
External dispensing , see 040 2.6 External dispensing	Off
	Pre-wash
	Main wash
	Pre-wash, main wash
Temperature	Celsius [°C]
	Fahrenheit [°F]
Payment system operation , see 080 2.5 Payment system programmable function	Off (Delay start possible)
	Programme operation
	Timed operation
Controlled energy consumption	Off
	On: In Cottons and Minimum iron
Supervisor level code , see 080 2.6 Operator code programmable function	Code not required. Domestic programmable functions can be modified.
	Code required. After code entry, domestic and supervisor programmable functions can be modified.
Heater rating , see 080 2.9 Heater rating programmable function	2100 W
	4200 W
	2650 W
	3000 W
	4600 W
	5300 W
Heating , see 080 2.10 Heating programmable function	Off: No heating, no Thermostop
	On: Heating active, Thermostop active

Programmable function	Option
Drum lighting , see 080 2.13 Drum lighting programmable function	Passive: If a washing machine is without drum lighting, the drum lighting function must be deactivated.
	Active
Reset standard setting	Resets all programmable functions to standard settings

Table 2: Programming mode summary

Save and quit

Note

Confirmed programmable options are saved.

- ✎ Reconnect the suds temperature sensor (R30) plug to the power-programme module (ELP).

4.3 Demonstration mode activation / deactivation

PW 6055, PW 6065

Initial requirements

- ✎ Finish or cancel any programme in operation.
- ✎ Open the door.
- ✎ If the international multilingual start screen is shown, select the desired language.

Accessing

Note

After it is begun, the accessing procedure must be completed within 10 s.

- ✎ Press and hold the **Start** button.
- ✎ Close the door.
- ✎ As soon as the **Start** button **lights up constantly**, after approx. 5 s, release the **Start** button.

Note

During deactivation the **Start** button does not light up constantly.

- ↺ Immediately press and hold the **Start** button until an appropriate instruction is shown in the display (approx. 5 s).
- ↺ Follow the instruction shown in the display.

Acknowledgement indicator

The demonstration programme operates.

If the accessing procedure has been unsuccessful, the control automatically reverts to the normal operating mode.

Options

The demonstration mode programme duration is approx. 90 s. After a short pause, it starts again automatically.

Note

After an interruption in the mains supply, the demonstration mode programme begins again automatically.

Save and quit

- ↺ Demonstration programme deactivation: Repeat the accessing procedure.

4.4 Demonstration mode activation / deactivation

PW 5065

Initial requirements

- ↺ Finish or cancel any programme in operation.
- ↺ Open the door.

Accessing

Note

After it is begun, the accessing procedure must be completed within 10 s.

- ↺ Press and hold the **Start** button.
- ↺ Close the door.
- ↺ As soon as the **Start LED lights up constantly**, after approx. 5 s, release the **Start** button.

- ✎ Immediately press and hold the **Start** button until an appropriate instruction is shown in the display (approx. 5 s).
- ✎ Follow the instruction shown in the display.

Acknowledgement indicator

The demonstration programme operates.

If the accessing procedure has been unsuccessful, the control automatically reverts to the normal operating mode.

Options

The demonstration mode programme duration is approx. 90 s. After a short pause, it starts again automatically.

Note

After an interruption in the mains supply, the demonstration mode programme begins again automatically.

Save and quit

- ✎ Demonstration programme deactivation: Repeat the accessing procedure.

4.5 Service mode summary

PW 6055, PW 6065

Initial requirements

- ✎ Ensure the machine is installed and connected correctly.
- ✎ Finish or cancel any programme in operation, including the demonstration mode.
- ✎ Open the door.
- ✎ If the international multilingual start screen is shown, select the desired language.

Accessing

Note

After it is begun, the accessing procedure must be completed within 10 s.

- ✎ Press and hold the **Start** button.
- ✎ Close the door.
- ✎ As soon as the **Start** button flashes, release the **Start** button.
- ✎ Immediately press and release the **Start** button **3 times** and at the **3rd time hold it pressed in** until service mode functions are shown in the display.

Acknowledgement indicator

Successful accessing of the service mode is indicated by slow flashing of the **Start** button (1 Hz).

The display shows the service mode functions.

If the accessing procedure has been unsuccessful, the control automatically reverts to the normal operating mode.

Options

- ✎ **Service function selection:** Turn the multifunction selector switch as appropriate.
- ✎ **Service function start and test step advance:** Press the **Start** button.

Note

The service mode is switched off automatically 30 min after the last service function has been checked.

Service function	Component / Sensor tested		
Software version	Selection module (EW) ID no. Power-programme module (ELP) ID no.		
Fault register display ¹⁾ and deletion ²⁾	Fault cause	Fault code	Remedy
	No fault registered	F 0	None required F 0 , no fault, 080 3.4
	Water/Heating NTC sensor short-circuited	F 1	See Fault code F 1 , water/heating NTC sensor short-circuited, 080 3.5
	Water/Heating NTC sensor open-circuited	F 2	See Fault code F 2 , water/heating NTC sensor, 080 3.6
	Water intake fault – Cold water	F 10	See Fault code F10 , cold water intake, 080 3.7
	Drainage fault	F 11	See Fault code F11 , water drainage, 080 3.8
	Water intake fault – Hot water	F 15	See Fault code F15 , hot water intake, 080 3.9
	Excess foam	F 16	See Fault code F16 , excess foam, 080 3.10
	Heating fault (Thermostop temperature not reached)	F 20	See Fault code F20 , heating, 080 3.11
	Faulty EEPROM / data fault	F 41	See Fault code F41 , faulty EEPROM / data fault, 080 3.12
	Model type not programmed	F 43	See Fault code F43 , model type not programmed, 080 3.13
	Flash fault	F 45	See Fault code F45 , faulty flash RAM / incorrect data, 080 3.15
	Display fault	F 46	See Fault code F46 , display fault, 080 3.16
	Interface fault between EW / ELP electronic modules	F 47	See Fault code F47 , selection module (EW) – Power-programme module (ELP) interface fault, 080 3.17
	Drive fault	F 50	See Fault code F50 , drive fault, 080 3.18
	Pressure sensor fault	F 51	See Fault code F51 , pressure sensor, 080 3.19
	Tachogenerator fault (speed sensor)	F 53	See Fault code F53 , tachogenerator, 080 3.20
No spin	F 56	See Fault code F56 , no spin, 080 3.21	
Water path control unit fault	F 63	See Fault code F63 , water path control unit, 080 3.22	
Drum lighting cap missing	F 65	See Fault code F65 , drum lighting cap missing, 080 3.23	

Service function	Component / Sensor tested	
Component activation	Component activation	Function tested/Machine response
	Water path control unit M 24 position 1 and Y14	Water intake via door glass for 10 s
	Water path control unit M 24 position 2, solenoid valve Y14, heating R1 + R2, analog pressure sensor	Water intake via compartment I, until level I is reached. Heating to 35° C then begins.
	Water path control unit M 24 position 3, solenoid valve Y14, analog pressure sensor	Water intake via compartment II, until level II is reached
	Water path control unit M 24 position 4, solenoid valve Y14, analog pressure sensor	Water intake via compartment III (fabric conditioner), until level III is reached
	Drain pump M8 / Drain valve Y26	Drain pump M8 activated / Drain valve Y26 opened. Drainage without level control.
	Wash agitation, drum drive motor M5	Drum rotation with reversing action
	Spin drive, drum drive motor M5	Drain pump M8 activated / Drain valve Y26 opened, drum drive motor M5 activated. Drainage and spinning depending on spin speed selector setting.
	Hot water valve Y12	Water intake via compartment II, until level III is reached
	Drum lighting H3/6	Drum lighting on
	Alternative water supply valve Y6	Water intake via compartment II, until level III is reached
	Dispensing relay 1M9	Dispenser relay activation
	Dispensing relay 2M9	Dispenser relay activation
	Dispensing relay 3M9	Dispenser relay activation
	Dispensing relay 4M9	Dispenser relay activation
	Programme end signal	Mains voltage applied to pin 7 of payment system socket (X1/1)
Sensor test	Sensor	State
	Door contact (A2)	Door closed => Switch closed
		Door open => Switch open
	Payment system contact, payment system socket (X1/1)	Connection wire bridge fitted between 1W14 pin 2/4 and 2W/14 pin 3/5
Connection wire bridge not fitted between 1W14 pin 2/4 and 2W/14 pin 3/5		
Operating hours counter display	Power-programme module (ELP)	Operating hours display
Controls	Buttons	Display indication for activated buttons
	Display / LED test	All display points flash at the same time
	Display background light (backlight)	The backlight flashes on and off
	Selection module (EW) test	See display for test results
Calibration	Calibration not required as the machine does not have a load sensor	

Table 3: Service mode summary

- ¹⁾ If **several faults** are registered, their codes are shown one after the other in ascending order when the **Start** button is pressed.
- ²⁾ **Fault code deletion:** Press the **Start** button for longer than 5 s during the fault code display (all stored fault codes are deleted).

Quit (without saving)

 Open the door.

Note

Quitting from the calibration service function is not possible.

4.6 Service mode summary

PW 5065

Initial requirements

- ✎ Ensure the machine is installed and connected correctly.
- ✎ Finish or cancel any programme in operation, including the demonstration mode.
- ✎ Open the door.

Accessing

Note

After it is begun, the accessing procedure must be completed within 10 s.

- ✎ Press and hold the **Start** button.
- ✎ Close the door.
- ✎ As soon as the **Start** LED flashes, release the **Start** button.
- ✎ Immediately press and release the **Start** button **3 times** and at the **3rd time hold it pressed in** until the **Start** LED flashes slowly.

Acknowledgement indicator

Successful accessing of the service mode is indicated by slow flashing of the **Start** LED (1 Hz).

The display shows the service mode functions.

If the accessing procedure has been unsuccessful, the control automatically reverts to the normal operating mode.

Options

- ✎ **Service function selection:** Press the + / - buttons as appropriate.
- ✎ **Service function start and test step advance:** Press the **OK** button.
- ✎ **Back to main level:** Press the **OK** button.

Note

The service mode is switched off automatically 30 min after the last service function has been checked.

Service function	Component / Sensor tested		
Software version	Selection module (EW) ID no. Power-programme module (ELP) ID no.		
Fault register display ¹⁾ and deletion ²⁾	Fault cause	Fault code	Remedy
	No fault registered	F 0	None required F 0 , no fault, 080 3.4
	Water/Heating NTC sensor short-circuited	F 1	See Fault code F 1 , water/heating NTC sensor short-circuited, 080 3.5
	Water/Heating NTC sensor open-circuited	F 2	See Fault code F 2 , water/heating NTC sensor, 080 3.6
	Water intake fault – Cold water	F 10	See Fault code F10 , cold water intake, 080 3.7
	Drainage fault	F 11	See Fault code F11 , water drainage, 080 3.8
	Excess foam	F 16	See Fault code F16 , excess foam, 080 3.10
	Heating fault (Thermostop temperature not reached)	F 20	See Fault code F20 , heating, 080 3.11
	Faulty EEPROM / data fault	F 41	See Fault code F41 , faulty EEPROM / data fault, 080 3.12
	I ² C bus connection faulty	F 44	See Fault code F44 , I ² C bus connection faulty, 080 3.14
	Interface fault between EW / ELP electronic modules	F 47	See Fault code F47 , selection module (EW) – Power-programme module (ELP) interface fault, 080 3.17
	Drive fault	F 50	See Fault code F50 , drive fault, 080 3.18
	Pressure sensor fault	F 51	See Fault code F51 , pressure sensor, 080 3.19
	Tachogenerator fault (speed sensor)	F 53	See Fault code F53 , tachogenerator, 080 3.20
	Water path control unit fault	F 63	See Fault code F63 , water path control unit, 080 3.22
Drum lighting cap missing	F 65	See Fault code F65 , drum lighting cap missing, 080 3.23	

Service function	Component / Sensor tested	
Component activation	Component activation	Function tested/Machine response
	Water path control unit M 24 position 1 and Y14	Water intake via door glass for 10 s
	Water path control unit M 24 position 2, solenoid valve Y14, heating R1 + R2, analog pressure sensor	Water intake via compartment I, until level I is reached. Heating to 35°C then begins.
	Water path control unit M 24 position 3, solenoid valve Y14, analog pressure sensor	Water intake via compartment II, until level II is reached
	Water path control unit M 24 position 4, solenoid valve Y14, analog pressure sensor	Water intake via compartment III (fabric conditioner), until level III is reached
	Drain pump M8 / Drain valve Y26	Drain pump M8 activated / Drain valve Y26 opened. Drainage without level control.
	Wash agitation, drum drive motor M5	Drum rotation with reversing action
	Spin drive, drum drive motor M5	Drain pump M8 activated / Drain valve Y26 opened, drum drive motor M5 activated. Drainage and spinning depending on spin speed selector setting.
	Hot water valve Y12	Water intake via compartment II, until level III is reached
	Drum lighting H3/6	Drum lighting on
	Dispensing relay 1M9	Dispenser relay activation
	Programme end signal	Mains voltage applied to pin 7 of payment system socket (X1/1)
	Sensor test	Sensor
Door contact (A2)		Door closed => Switch closed
		Door open => Switch open
Payment system contact, payment system socket (X1/1)		Connection wire bridge fitted between 1W14 pin 2/4 and 2W/14 pin 3/5
	Connection wire bridge not fitted between 1W14 pin 2/4 and 2W/14 pin 3/5	
Operating hours counter display	Power-programme module (ELP)	Operating hours display
Controls	Buttons	Display indication for activated buttons
	Display / LED test	All display points flash at the same time
	Display background light (backlight)	The backlight flashes on and off
	Rotary selector switch (DWS) test	Programme positions: 0 - 21

Table 4: Service mode summary

- 1) If **several faults** are registered, their codes are shown one after the other in ascending order when the **Start** button is pressed.
- 2) **Fault code deletion:** Press the **Start** button for longer than 5 s during the fault code display (all stored fault codes are deleted).

Quit (without saving)

 Open the door.

090 Electrical components

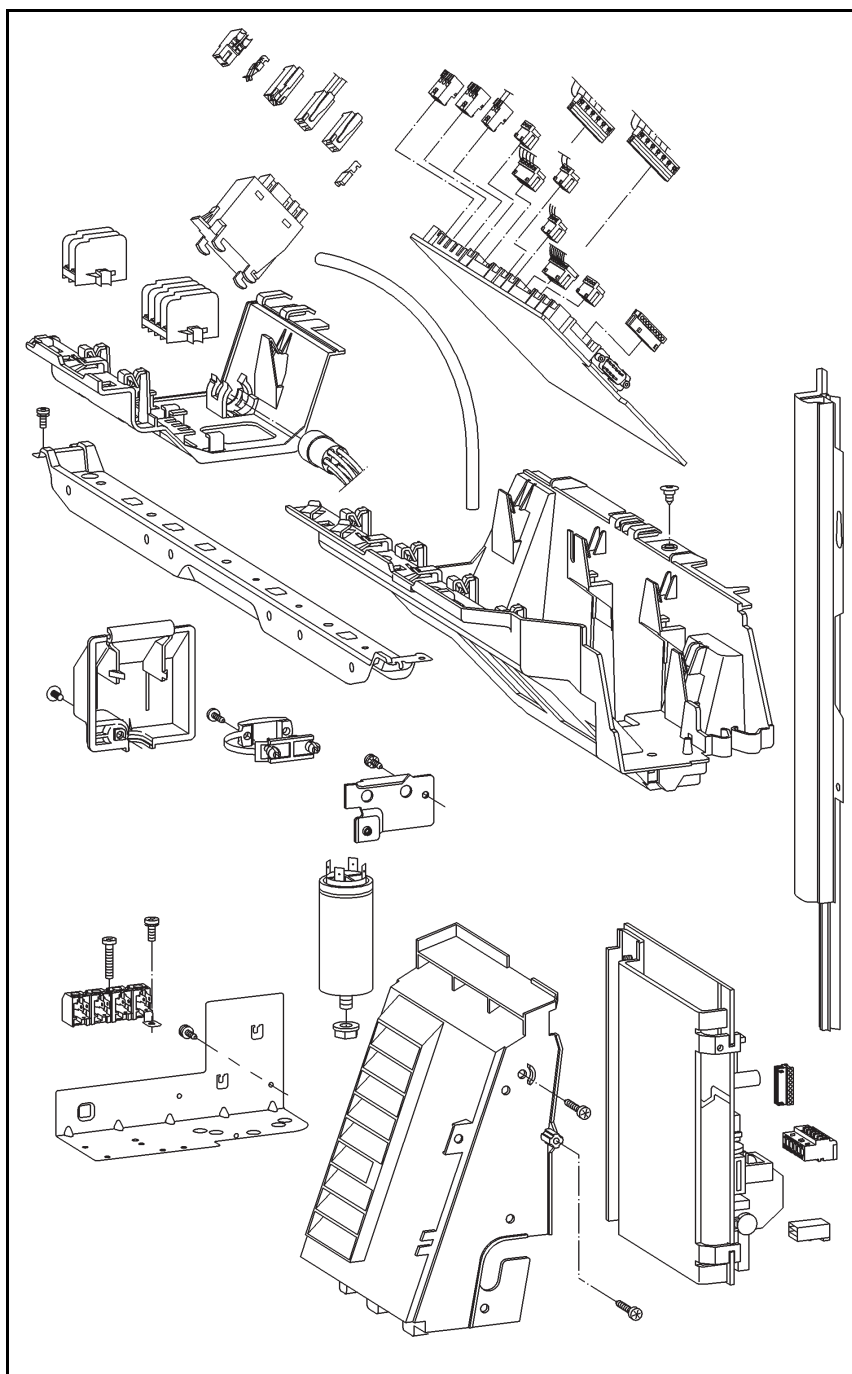

2 Function

2.1 Payment system socket (X1/1)

Payment system socket (X1/1) - Washing machine side	Potential	Pin
Voltage supply switched by washing machine (ready for operation signal)	L`	1
Start permitted by payment system	L`	2
Voltage supply direct for payment system	N	3
Voltage supply direct for payment system	L	4
Neutral switched by payment system	N`	5
Direct earth conductor	PE	6
Programme end signal	L`	7

Table 1: Payment system socket (X1/1) pin allocation

2.2 Payment system

The washing machine is pre-fitted with the requirements for operation in conjunction with a payment system.

Three minutes after programme start, the door and programme are locked.

Payment system (programme operation):

The payment system provides the machine with a “start permitted” signal. After the programme has been started, it continues without further influence from the payment system.

For further details, see Payment system (programme operation), 090 4.3.

Payment system (timed operation):

The payment system provides the machine with a constant “operation permitted” signal throughout the period of timed operation that has been purchased.

The programme continues so long as the signal is provided.

If the signal is interrupted, the programme and time left are stopped and the machine components are switched off.

For further details, see Payment system (timed operation), 090 4.4.

2.3 Central control via RS 232 interface with 9-pole plug

PW 6055, PW 6065

Possible to use one central control/payment system.

Control data can be read and modified.

For further details, see Central control via RS 232 interface, 090 4.5.

4 Service

4.1 Working on frequency converter electronic unit (EFU)

PW 6055, PW 6065

Danger!

Risk of electric shock when working on frequency converter electronic unit (EFU).

A capacitor on the frequency converter electronic unit holds an electrical charge with a potential difference of up to approx. 400 V, even after disconnection from the mains.

After disconnection from the mains a discharge resistor connected in parallel with the capacitor should discharge it within approx. 2 min.

For safety reasons before working on any of the frequency converter (EFU) components it is essential to ensure that this discharge has in fact taken place.

4.2 Fitting payment system on machine lid

✂ Remove the machine lid.

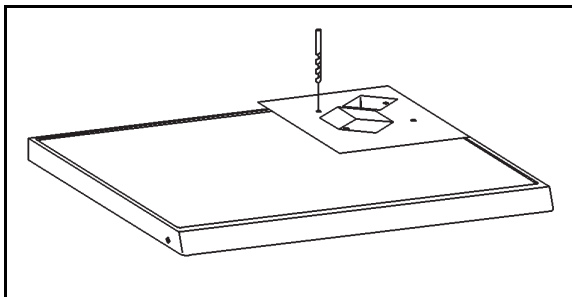
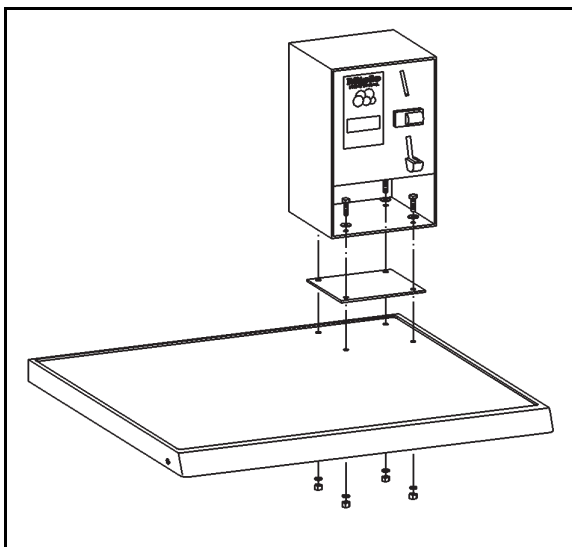

Fig. 1

Warning!

When drilling through the machine lid take care to not drill into the surface on which it is resting!

✂ Drill 4 fixing holes through the machine lid in accordance with the payment system template.

**Fig. 2**

- ✎ Place the plastic underlay on the machine lid. Secure the payment system to the lid on the underlay using the screws, washers, retaining rings and nuts provided.

Note

For further details, see Payment system (programme operation), 090 4.3, Payment system (timed operation), 090 4.4.

- ✎ Refit the machine lid.

4.3 Payment system (programme operation)

Note

The instructions given in the documentation provided with the payment system must be followed.

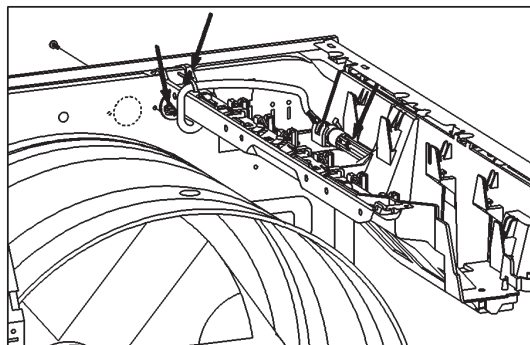
**Fig. 3**

- ✎ Open the pre-punched opening/s in the rear casing for the electrical connections as necessary.

Warning!

Take care to lay wires such that they cannot be damaged by sharp edges.

- ✎ Fit the appropriate through-feed parts on the wires. Secure the through-feeds on the rear casing.
- ✎ Lay the payment system wire to the payment system socket (X1/1).
- ✎ At the payment system socket (X1/1), cut through the wire bridge 1W14 between pins 2 and 4. Insulate the wire ends.
- ✎ PW 6055 and PW 6065: Set the payment system programmable option to **Programme operation**, see Programming mode summary, 080 4.1.
- ✎ PW 5065: Set the payment system programmable option to **Programme operation**, see Programming mode summary, 080 4.2.
- ✎ Fit the payment system on the machine lid, see Fitting payment system on machine lid, 090 4.2.

4.4 Payment system (timed operation)

Note

The instructions given in the documentation provided with the payment system must be followed.

Warning!

The connection has been modified.

Danger of short circuit.

When a time payment system C 5003 is fitted, the connection from pin 7 to connection 2 on the payment system must be disconnected.

A bridge must be made in the payment system from connection 3 (operational signal) to connection 2 (transformer).

With incorrect connection, connection from pin 7 to connection 2 on the payment system not disconnected, a short circuit will exist at the end of the programme.

Check the wiring diagram.

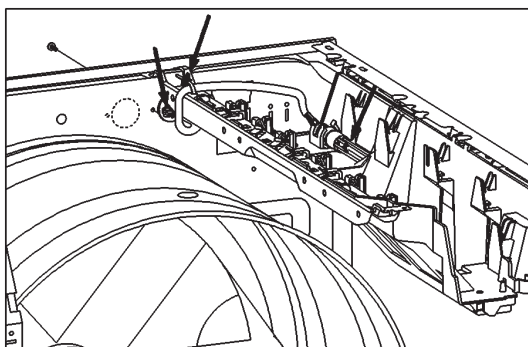

Fig. 4

- ✎ Open the pre-punched opening/s in the rear casing for the electrical connections as necessary.

Warning!

Take care to lay wires such that they cannot be damaged by sharp edges.

- ✎ Fit the appropriate through-feed parts on the wires. Secure the through-feeds on the rear casing.
- ✎ Lay the payment system wire to the payment system socket (X1/1).
- ✎ At the payment system socket (X1/1), cut through the wire bridge 2W14 between pins 3 and 5. Insulate the wire ends.

- ✚ PW 6055 and PW 6065: Set the payment system programmable option to **Timed operation**, see Programming mode summary, 080 4.1.
- ✚ PW 5065: Set the payment system programmable option to **Timed operation**, see Programming mode summary, 080 4.2.
- ✚ Fit the payment system on the machine lid, see Fitting payment system on machine lid, 090 4.2.

4.5 Central control via RS 232 interface

PW 6055, PW 6065

Danger!

Risk of electric shock due to voltage transfer with incorrectly laid data cables.

Note

The instructions given in the documentation provided with the central control must be followed.

Warning!

Take care to lay wires such that they cannot be damaged by sharp edges.

- ✚ Remove the machine lid.

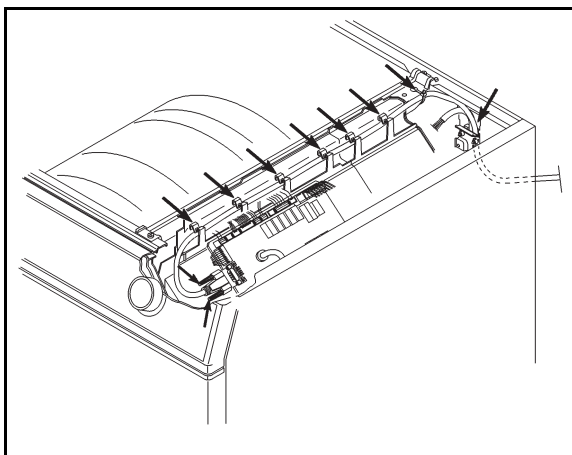
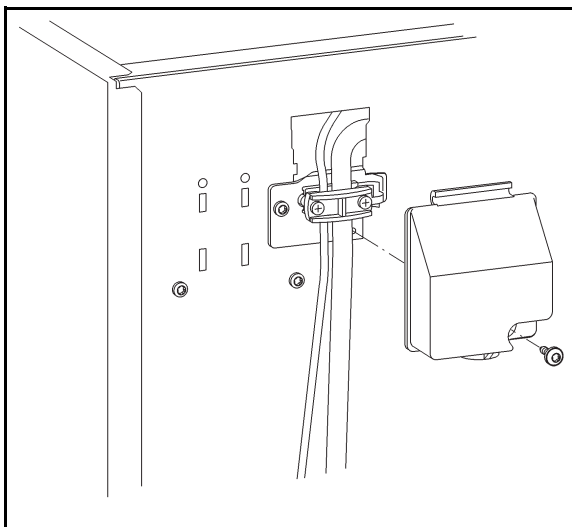

Fig. 5

**Fig. 6**

- ✚ Unscrew and remove the connection box lid. Loosen the cable strain relief.
- ✚ Pass the data cable through the casing opening for the mains connection cable. Lay the data cable to the RS 232 interface on the power-programme module (ELP).
- ✚ Connect the data cable plug to the RS 232 interface and secure it with the screws.
- ✚ Fasten the data cable to the transverse strut with cable ties. Secure the data cable in the strain relief together with the mains connection cable. Refit the connection box lid.
- ✚ At the payment system socket (X1/1), cut either through the wire bridge 1W14 between pins 2 and 4 or the wire bridge 2W14 between pins 3 and 5 as desired. Insulate the wire ends.
- ✚ At the washing machine, set the payment system programmable option to **RS 232**, see Programming mode summary, 080 4.1.

