

Your safety, and the safety of others, is very important. To help you make informed decisions about safety, we have provided installation and operating instructions and other information on labels and in this guide. This information alerts you to potential hazards that could hurt you or others. It is not possible to warn you about all potential hazards associated with this product, you must use your own good judgment.

CARELESS WINCH INSTALLATION AND OPERATION CAN RESULT IN SERIOUS INJURY OR EQUIPMENT DAMAGE. READ AND UNDERSTAND ALL SAFETY PRECAUTIONS AND OPERATING INSTRUCTIONS BEFORE INSTALLING AND OPERATING THIS PRODUCT.

This guide identifies potential hazards and has important safety messages that help you and others avoid personal injury or death. **WARNING** and **CAUTION** are signal words that identify the level of hazard. These signal words mean:

 **WARNING** signals a hazard that could cause serious injury or death, if you do not follow recommendations.

 **CAUTION** signals a hazard that may cause minor to moderate injury, if you do not follow recommendations.

This guide uses  **NOTICE** to call attention to important mechanical information, and **Note**: to emphasize general information worthy of special attention

Introduction

Thank you for choosing CAMEL WORKS for your utility winch needs. All CAMEL products have been designed and manufactured for many years of problem-free operation. For future reference please record the following information:

Model/Part Number: _____ **Date of Purchase:** _____

Before you begin

- Read the instructions completely to familiarize yourself with the installation process.
- Review all the notices, cautions and warnings to make sure the kit will be installed correctly and safely.

Safety Precautions

The following are general safety precautions that every winch operator should know. Taking precedence over any specific rule listed here, however, is the most important rule of all—**USE COMMON SENSE**.

A few minutes spent reading these rules can make an operator aware of dangerous practices to avoid and precautions to take for his own safety and the safety of others. Frequent examinations and periodic inspections of the equipment as well as conscientious observance of safety rules may save lives as well as time and money.

WARNING

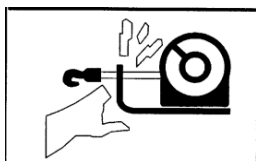

MOVING PARTS ENTANGLEMENT HAZARD

Failure to observe these instructions could lead to severe injury or death.

To avoid injury to hands or fingers.

- **Always** keep hands clear of wire rope, hook loop, hook and fairlead opening during installation, operation and when spooling in or out.
- **Always** use extreme caution when handling hook and wire rope during spooling operations.
- **Always** use supplied hook strap whenever spooling wire rope in or out, during installation or operation to avoid injury to hands or fingers.

WARNING

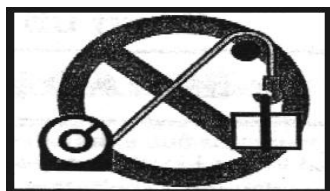

FALLING OR CRUSHING HAZARD

Failure to observe these instructions could lead to severe injury or death.

- **Never** use as an overhead hoist, or to suspend a load.
- **Never** use to lift or move persons.

Safety Precautions - continued



CAUTION

MOVING PARTS ENTANGLEMENT HAZARD

Failure to observe these instructions could lead to minor to moderate injury.

General Safety:

- **Always** Know Your Winch: Take time to fully read and understand the included Installation and Operations guide, and Basic Guide to Winching Techniques, in order to understand your winch and the winching operation.
- **Never** operate this winch if you are under 16 years of age.
- **Never** operate this winch when under the influence of drugs, alcohol or medication.
- **Never** exceed winch or wire rope rated capacity. Double line using a snatch block to reduce winch load.

Installation Safety:

- **Always** choose a mounting location that is sufficiently strong to withstand the maximum pulling capacity of your winch.
- **Always** use factory approved switches, remote controls, accessories and installation components.
- **Always** use grade 5 or better hardware, never weld bolts and never use longer bolts than those supplied from factory.
- **Always** complete winch mounting and attachment of hook to hook loop before wiring winch during installation.
- **Always** position fairlead with WARNING label on top.
- **Always** spool the wire rope onto the drum as indicated by the drum rotation label on the winch. Required for automatic brake to work (if winch is so equipped) and for correct installation orientation.
- **Always** prestretch wire rope and respool under load before use. Tightly wound wire rope reduces chances of "binding", which is wire rope working it's way down into a loosely wound wire rope layer, and catching or damaging itself.

Winching Safety:

- **Always** inspect winch installation and wire rope and hook condition before operating winch. Frayed, kinked or damaged wire rope must be replaced immediately. Loose or damaged winch installation must be corrected immediately.
- **Never** hook wire rope back onto itself. This damages the wire rope. Always use a choker chain, wire choker rope or tree trunk protector on the anchor.
- **Always** prior to winching, remove any element that may interfere with safe winch operation.
- **Always** take your time when rigging for a winch pull.
- **Always** be certain the anchor you select will withstand the load, and the strap or chain will not slip.
- **Never** engage or disengage clutch if winch is under load, wire rope is in tension or wire rope drum is moving
- **Always** unspool as much wire rope as possible when rigging. Double line or pick distant anchor point.
- **Never** winch with less than 5 wraps of wire rope around the drum, the wire rope could come loose from the drum.
- **Always** stand clear of wire rope and load during operation.
- **Never** touch wire rope or hook while in tension or under load.
- **Never** touch wire rope or hook while someone else is at the control switch or during winching operation.
- **Never** touch wire rope or hook while remote control is plugged into winch.
- **Always** stand clear of wire rope and load and keep others away while winching.
- **Always** require operator and bystanders to be aware of stability during winching of vehicle and/or load.
- **Always** keep remote control lead clear of the drum, wire rope and rigging. Inspect for cracks, pinches, frayed wires or loose connections. Replace if damaged.

Safety Precautions - continued



CAUTION



CUT AND BURN HAZARD

Failure to observe these instructions could lead to minor to moderate injury.

To avoid injury to hands and fingers:

- **Always** wear heavy leather gloves when handling a wire rope.
- **Never** let wire rope slip through your hands.
- **Always** be aware of possible hot surface at winch motor, drum or wire rope during or after winch use.



CAUTION

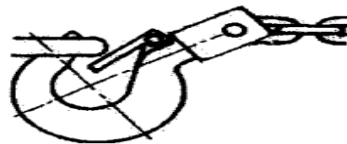
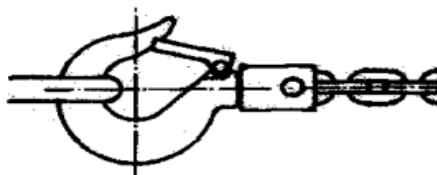

Moving Parts Entanglement Hazard

Failure to observe these instructions could lead to minor to moderate injury.

- **Never** apply load to hook tip or latch. Apply load only to the center of hook.
- **Never** use a hook whose throat opening has increased, or whose tip is bent or twisted.

NOTICE

AVOID WINCH AND EQUIPMENT DAMAGE

- **Always** avoid continuous side pulls, which can pile up wire rope at one end of the drum. This can damage your wire rope or winch.
- **Always** ensure the clutch is fully engaged or Disengaged.
- **Never** use winch to tow other vehicles. Shock loads can momentarily exceed capacity of wire rope & winch
- **Always** use care to not damage your frame when anchoring your vehicle during a winching operation.
- **Never** "jog" wire rope under load. Shock loads can momentarily exceed capacity of wire rope and winch.
- **Never** use winch to secure a load during transport.
- **Never** submerge winch in water.
- **Always** store the winch in a protected, clean, dry area.

Winch Installation to fixed location



CAUTION

Winch Failure Hazard

Failure to observe these instructions could lead to minor or moderate injury.

- Always choose a mounting location that is sufficiently strong to withstand the loads you intend to winch

Wiring Instructions



WARNING

Shock & Fire Hazard

Failure to observe these instructions could lead to severe injury or death.

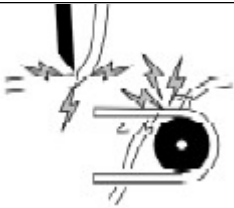

- Never route electrical cables across sharp edges
- Never route electrical cables through or near moving parts.
- Always read and follow all wiring instructions included in operators guide.
- Always insulate and protect all exposed wiring and electrical terminals

- Install battery cables with red lead connected to the positive terminal of battery, and black lead to the negative terminal of battery.
- Verify that all wiring connections are clean and tight.

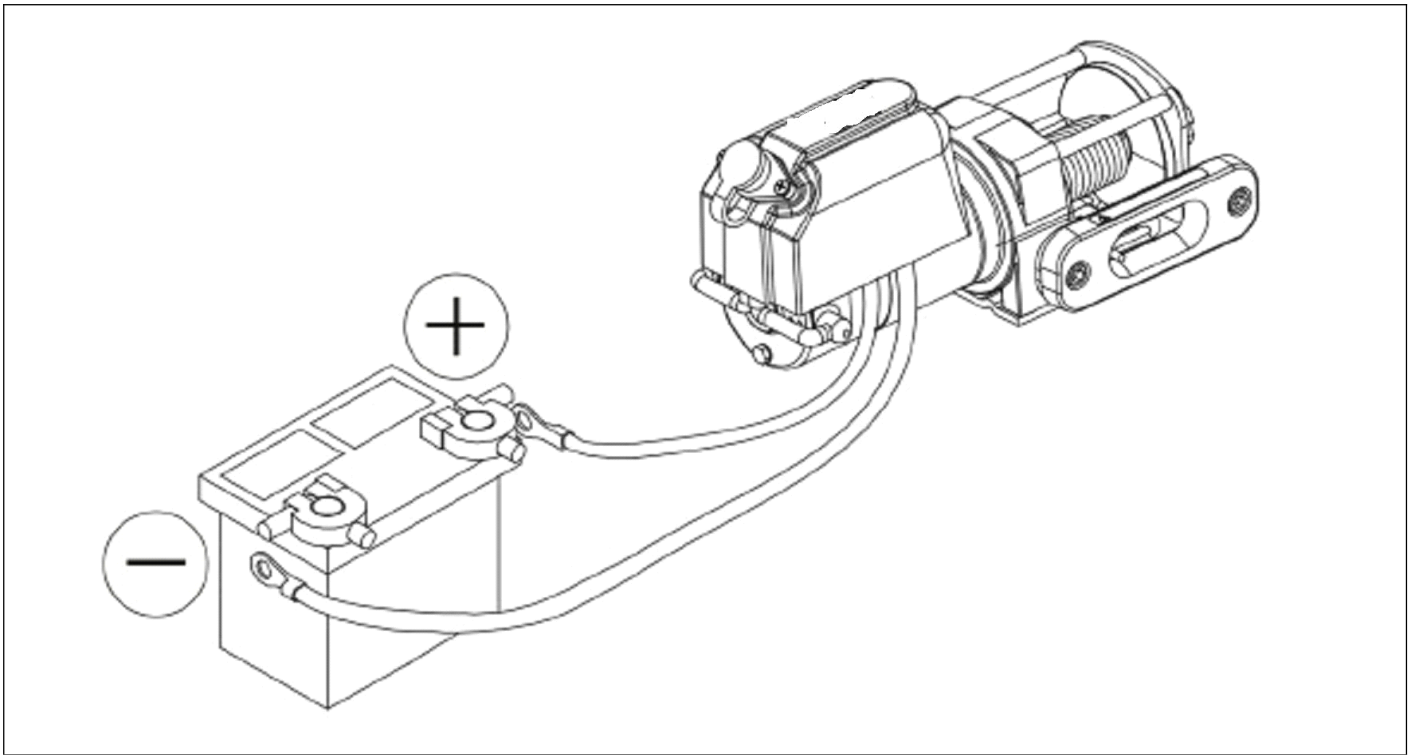

Before using the winch, verify the following:

- Wiring to all components is correct.
- There are no exposed wiring or terminals, cover any existing exposures with insulator plate, terminal boots, heat shrink tubing or electrician's tape.

Operating Instructions

USING WIRELESS REMOTE CONTROL AND HANDLE REMOTE CONTROL

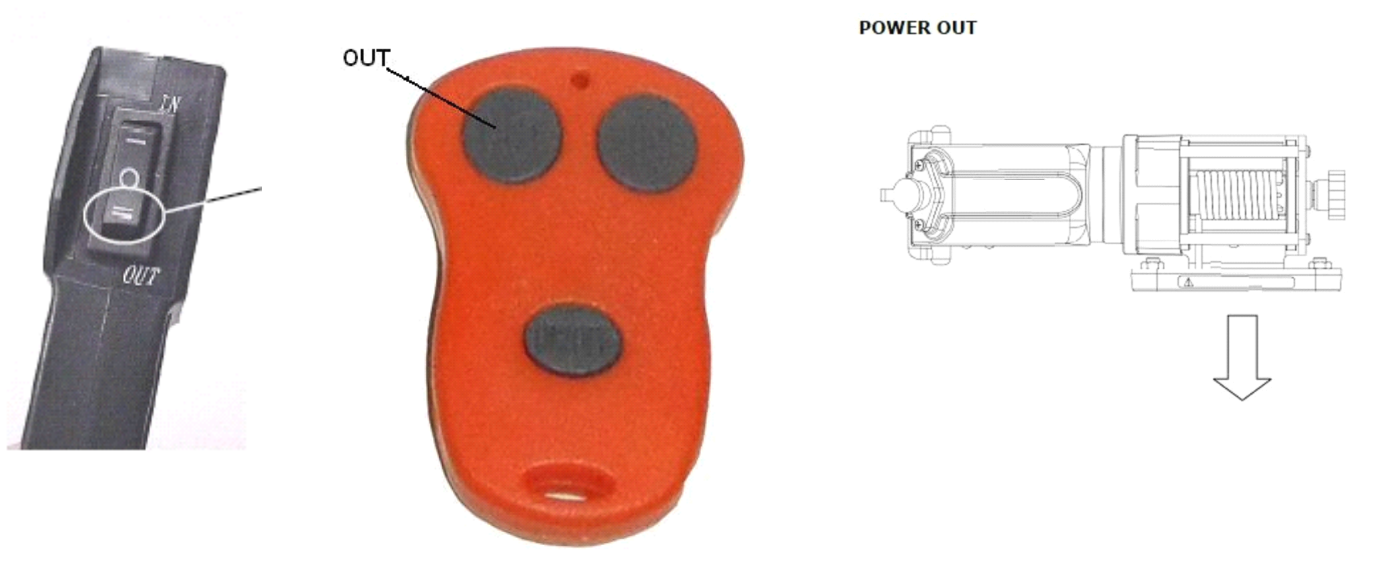
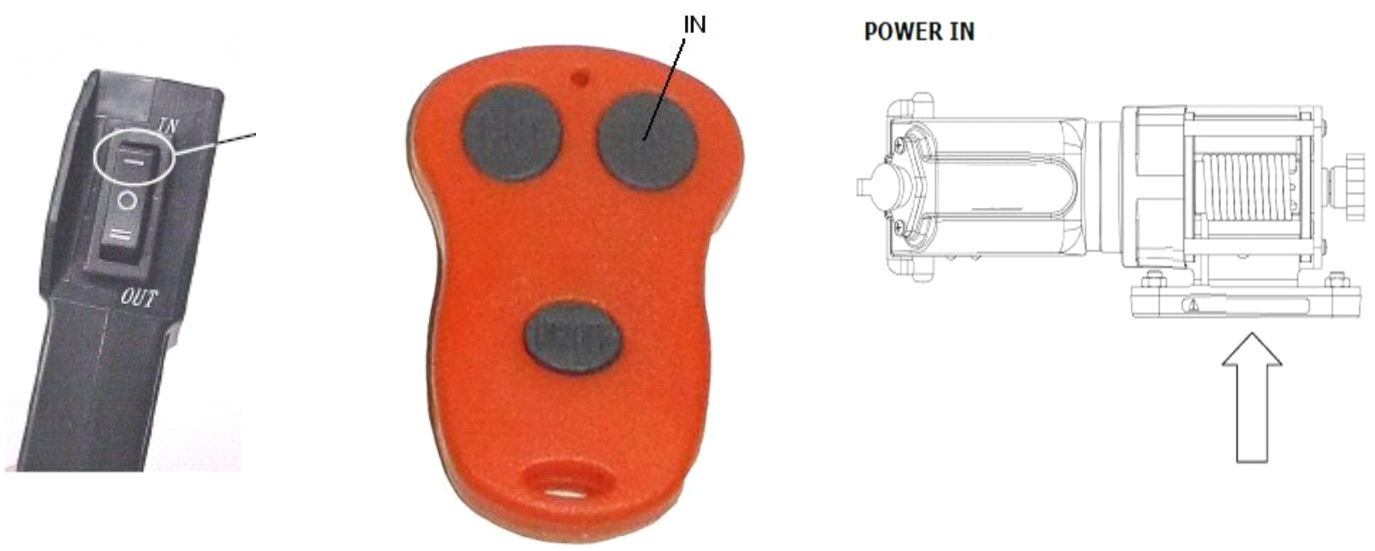

Operating Instructions - continued

CLUTCH OPERATION

WARNING

Winch Function Hazard

Failure to observe these instructions could lead to severe injury or death.

- Never engage or disengage the clutch if the winch is under load or wire rope is under tension.**

When the clutch is engaged the gear train is coupled to the wire rope drum and power may be transferred from the winch motor. When the clutch is in freespool the gear train and wire rope drum are uncoupled allowing the drum to rotate freely. The clutch knob, located on the side, controls the clutch position. To prevent damage, always fully engage or fully disengage the clutch knob.

Engaged



Disengaged

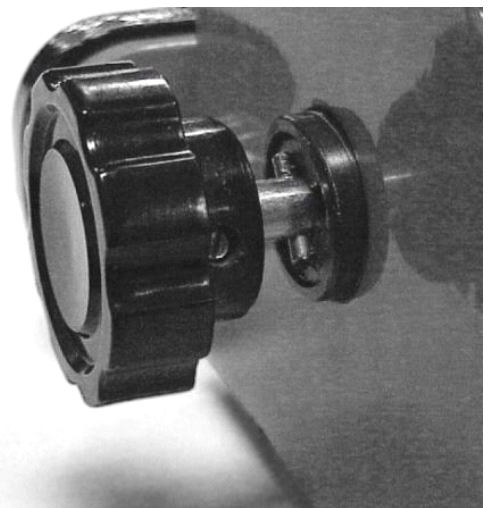

Operating Instructions - continued

SPOOLING OUT

Freespooling is generally the quickest and easiest way to spool out wire rope. Before freespooling wire rope out from the winch, power out enough rope to remove any tension the wire rope may be under before disengaging the clutch. Now freespool by manually spooling out enough wire rope for the winching operation.



CAUTION

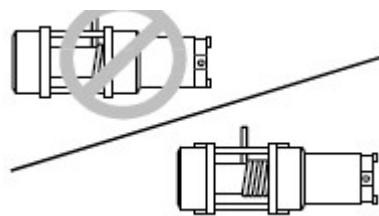

Personal injury Hazard

Failure to observe these instructions could lead to minor or moderate injury.

- Always wear leather gloves when handling wire rope**
- Never winch with less than 5 wraps of wire rope around the drum**

STRETCHING THE WIRE ROPE

The life of a wire rope is directly related to the care and use it receives. During its first use, a new wire rope must be spooled onto its drum under a load of at least 500 lb. (227kg). Spool out the entire wire rope length leaving 5 wraps on the drum, then power in the wire rope under a load of 500 lb. (227kg) or more. This will stretch new wire rope and create a good wire wrap around the drum. Failure to do so may result in the outer wire wraps drawing into the inner wraps, binding, and damaging the wire rope.



WARNING

Moving Parts Entanglement Hazard

Failure to observe these instructions could lead to severe injury or death.



❑ **ALWAYS** keep hands clear of the wire rope, hook loop, hook and fairlead opening during installation, operation and when spooling in or out.



❑ **ALWAYS** use supplied hook strap whenever spooling the wire rope in or out, during installation, or operation to avoid injury to hands or fingers.

Operating Instructions - continued

SPOOLING IN UNDER LOAD

- ❑ The wire rope must always spool onto the bottom of the drum as indicated by decal on the winch.
- ❑ Power in the wire rope evenly and tightly on the drum. This prevents the outer wire wraps from drawing into the inner wraps, binding and damaging the wire rope.
- ❑ Avoid shock loads when spooling, by using the control switch intermittently to take up wire rope slack. Shock loads can momentarily far exceed the winch and wire rope ratings.
- ❑ To prolong the life of the winch, use a snatch block and a double-line rigging technique. This is especially important when pulling heavy loads.

SPOOLING IN UNDER NO LOAD

- ❑ **Assisted:** Have your assistant hold the hook with the hook strap putting as much constant tension on the wire rope as possible. While keeping tension, the assistant should walk toward the winch while you operate the control switch spooling in the wire rope. Release the switch when the hook is a minimum of 4 ft (1.2m) from the fairlead opening. Spool in the remainder for storage.
- ❑ **Unassisted:** Arrange the wire rope to be spooled so it will not kink or tangle when spooled. Be sure any wire rope on the drum is tightly and evenly layered. Spool enough wire rope to complete the next full layer on the drum. Tighten and straighten the layer. Repeat process until the hook is a minimum of 4ft (1.2m) from the fairlead. Spool in the remainder for storage.

SPOOLING REMAINDER FOR STORAGE

Keep hands clear of the wire rope, hook and fairlead opening. Always use the hook strap to hold hook when spooling under no load. Carefully power in the remaining wire rope, jogging the control switch to take up the last of the slack. Secure the hook to a suitable anchor point near the winch. Be careful not to over tighten or damage may occur to the wire rope or anchor point.

RIGGING

- ❑ Always spool out as much wire rope as possible when preparing rigging. Pick an anchor as far away as is practical; this provides the winch with its greatest pulling power.
- ❑ Rigging a double line with a snatch block will reduce the load on the winch to half without significant loss of spooling speed.
- ❑ Natural anchors such as trees, stumps and rocks are the handiest when available. Attach the choker chain, wire choker rope or tree trunk protector on the anchor as low as possible to avoid pulling the anchor down. If several possible anchors

are available but they are not strong enough individually, it may be practical to attach a wire or chain choker around several anchors to form a strong collective anchor point.

Operating Instructions - continued

OVERLOADING/OVERHEATING

This winch is rated for intermittent duty. It should not be operated with the motor slowed down to a low RPM. When the motor approaches stall speed, a very rapid heat build-up occurs which may cause motor damage. Double line rigging will reduce the amperage draw from the motor allowing longer continual use (see rigging section).

Maintenance & Warranty

MAINTENANCE

- No lubrication is required for the life of the winch.
- Inspect the wire rope before and after each winching operation. Replace when damaged.