

AIR CONDITIONING SYSTEMS

CITY MULTI



DATA BOOK

MODEL

PKFY-P-VLM-E

PKFY-P-VKM-E



PKFY-P-VLM-E, PKFY-P-VKM-E

1. SPECIFICATIONS	2
2. EXTERNAL DIMENSIONS	5
3. CENTER OF GRAVITY	8
4. ELECTRICAL WIRING DIAGRAMS	9
5. SOUND LEVELS	11
5-1. Sound levels	11
5-2. NC curves	11
6. TEMPERATURE/AIRFLOW DISTRIBUTIONS.....	12
6-1. Temperature distributions	12
6-2. Airflow distributions	13
7. ELECTRICAL CHARACTERISTICS.....	14
8. OPTIONAL PARTS.....	15
8-1. Optional parts line up for the Indoor unit.....	15
8-2. External LEV Box.....	15
8-3. Drain pump	16

1. SPECIFICATIONS

Wall mounted

PKFY-P-VLM-E, VKM-E

Model		PKFY-P10VLM-E	PKFY-P15VLM-E	PKFY-P20VLM-E
Power source		1-phase 220-240V 50Hz, 1-phase 220-230V 60Hz	1-phase 220-240V 50Hz, 1-phase 220-230V 60Hz	1-phase 220-240V 50Hz, 1-phase 220-230V 60Hz
Cooling capacity (Nominal)	*1 kW	1.2	1.7	2.2
	*1 kcal / h	1,000	1,500	1,900
	*1 BTU / h	4,100	5,800	7,500
	Power input	kW	0.02	0.02
(220V)	Current input	A	0.20	0.20
Heating capacity (Nominal)	*2 kW	1.4	1.9	2.5
	*2 kcal / h	1,200	1,600	2,200
	*2 BTU / h	4,800	6,500	8,500
	Power input	kW	0.01	0.01
(220V)	Current input	A	0.15	0.15
External finish		Plastic, MUNSELL (0.7PB 9.2/0.4)	Plastic, MUNSELL (0.7PB 9.2/0.4)	Plastic, MUNSELL (0.7PB 9.2/0.4)
External dimension HxWxD		mm	299x773x237	299x773x237
		in.	11-25/32 x 30-7/16 x 9-11/32	11-25/32 x 30-7/16 x 9-11/32
Net weight		kg(lbs)	11 (25)	11 (25)
Heat exchanger		Cross fin (Aluminum fin and copper tube)	Cross fin (Aluminum fin and copper tube)	Cross fin (Aluminum fin and copper tube)
FAN	Type x Quantity		Line flow fan x 1	Line flow fan x 1
	External static press.	Pa	0	0
		mmH ₂ O	0	0
	Motor Type		DC motor	DC motor
	Motor output		kW	0.030
	Driving mechanism		Direct-driven	Direct-driven
	Airflow rate (Low-Mid2-Mid-High)	m ³ / min	3.3-3.5-3.8-4.2	4.0-4.2-4.4-4.7
		L/s	55-58-63-70	67-70-73-78
cfm		117-124-134-148	141-148-155-166	
Sound pressure level (measured in anechoic room)		dB <A>	22-24-26-28	
Insulation material		Polyethylene sheet	Polyethylene sheet	
Air filter		PP honeycomb	PP honeycomb	
Protection device		Fuse	Fuse	
Refrigerant control device		LEV	LEV	
Connectable outdoor unit		R410A CITY MULTI	R410A CITY MULTI	
Diameter of refrigerant pipe	Liquid (R410A)	mm(in.)	6.35(1/4) Flare	
	Gas (R410A)	mm(in.)	12.70(1/2) Flare	
Field drain pipe size		mm(in.)	I.D. 16(5/8)	
Drawing	External		-	
	Wiring		-	
	Refrigerant cycle		-	
Standard attachment	Document		Installation Manual, Instruction Book	
	Accessory		-	
Optional parts	External LEV Box		PAC-SK17LE-E	
	Drain pump		PAC-SK01DM-E	
Remarks		* Details on foundation work, duct work, insulation work, electrical wiring, power source switch, and other items shall be referred to the Installation Manual. * Due to continuing improvement, above specification may be subject to change without notice.		

Notes:	*1 Nominal cooling conditions (subject to JIS B8615-1)	*2 Nominal heating conditions (subject to JIS B8615-1)	Unit converter
	Indoor: 27°C.D.B./19°C.W.B. (81°F.D.B./66°F.W.B.) Outdoor: 35°C.D.B. (95°F.D.B.) Pipe length: 7.5 m (24-9/16 ft.) Level difference: 0 m (0 ft.)	20°C.D.B. (68°F.D.B.) 7°C.D.B./6°C.W.B. (45°F.D.B./43°F.W.B.) 7.5 m (24-9/16 ft.) 0 m (0 ft.)	kcal/h = kW x 860 BTU/h = kW x 3,412 cfm = m ³ /min x 35.31 lbs = kg/0.4536
			*The specification data is subject to rounding variation.

1. SPECIFICATIONS

Wall mounted

Model			PKFY-P25VLM-E	PKFY-P32VLM-E	PKFY-P40VLM-E	
Power source			1-phase 220-240V 50Hz, 1-phase 220-230V 60Hz	1-phase 220-240V 50Hz, 1-phase 220-230V 60Hz	1-phase 220-240V 50Hz, 1-phase 220-230V 60Hz	
Cooling capacity (Nominal)	*1	kW	2.8	3.6	4.5	
	*1	kcal / h	2,400	3,100	3,900	
	*1	BTU / h	9,600	12,300	15,400	
	Power input		kW	0.03	0.04	0.04
(220V)		Current input	A	0.25	0.35	0.35
Heating capacity (Nominal)	*2	kW	3.2	4.0	5.0	
	*2	kcal / h	2,800	3,400	4,300	
	*2	BTU / h	10,900	13,600	17,100	
	Power input		kW	0.02	0.03	0.03
(220V)		Current input	A	0.20	0.30	
External finish			Plastic, MUNSELL (0.7PB 9.2/0.4)	Plastic, MUNSELL (0.7PB 9.2/0.4)	Plastic, MUNSELL (0.7PB 9.2/0.4)	
External dimension HxWxD		mm	299x773x237	299x773x237	299x898x237	
		in.	11-25/32 x 30-7/16 x 9-11/32	11-25/32 x 30-7/16 x 9-11/32	11-25/32 x 35-3/8 x 9-11/32	
Net weight		kg(lbs)	11 (25)	11 (25)	13(29)	
Heat exchanger			Cross fin (Aluminum fin and copper tube)	Cross fin (Aluminum fin and copper tube)	Cross fin (Aluminum fin and copper tube)	
FAN	Type x Quantity		Line flow fan x 1	Line flow fan x 1	Line flow fan x 1	
	External static press.	Pa	0	0	0	
		mmH ₂ O	0	0	0	
	Motor Type		DC motor	DC motor	DC motor	
	Motor output		kW	0.030	0.030	0.030
	Driving mechanism		Direct-driven	Direct-driven	Direct-driven	
	Airflow rate (Low-Mid2-Mid-High)	m ³ / min	4.0-4.6-5.4-6.7	4.3-5.4-6.9-8.4	6.3-7.4-8.6-10.0	
L/s		67-77-90-112	72-90-115-140	105-123-143-167		
cfm		141-162-191-237	152-191-244-297	222-261-304-353		
Sound pressure level (measured in anechoic room)		dB <A>	22-27-31-35	24-31-37-41	29-34-37-40	
Insulation material			Polyethylene sheet	Polyethylene sheet	Polyethylene sheet	
Air filter			PP honeycomb	PP honeycomb	PP honeycomb	
Protection device			Fuse	Fuse	Fuse	
Refrigerant control device			LEV	LEV	LEV	
Connectable outdoor unit			R410A CITY MULTI	R410A CITY MULTI	R410A CITY MULTI	
Diameter of refrigerant pipe	Liquid (R410A)	mm(in.)	6.35(1/4) Flare	6.35(1/4) Flare	6.35(1/4) Flare	
	Gas (R410A)	mm(in.)	12.70(1/2) Flare	12.70(1/2) Flare	12.70(1/2) Flare	
Field drain pipe size		mm(in.)	I.D. 16(5/8)	I.D. 16(5/8)	I.D. 16(5/8)	
Drawing	External		-	-	-	
	Wiring		-	-	-	
	Refrigerant cycle		-	-	-	
Standard attachment	Document		Installation Manual, Instruction Book	Installation Manual, Instruction Book	Installation Manual, Instruction Book	
	Accessory		-	-	-	
Optional parts	External LEV Box		PAC-SG95LE-E	PAC-SG95LE-E	PAC-SG95LE-E	
	Drain pump		PAC-SK01DM-E	PAC-SK01DM-E	PAC-SK01DM-E	
Remarks			* Details on foundation work, duct work, insulation work, electrical wiring, power source switch, and other items shall be referred to the Installation Manual. * Due to continuing improvement, above specification may be subject to change without notice.			

Notes:	*1 Nominal cooling conditions (subject to JIS B8615-1)	*2 Nominal heating conditions (subject to JIS B8615-1)	Unit converter
	Indoor: 27°C D.B./19°C W.B. (81°F D.B./66°F W.B.) Outdoor: 35°C D.B. (95°F D.B.) Pipe length: 7.5 m (24-9/16 ft.) Level difference: 0 m (0 ft.)	20°C D.B. (68°F D.B.) 7°C D.B./6°C W.B. (45°F D.B./43°F W.B.) 7.5 m (24-9/16 ft.) 0 m (0 ft.)	kcal/h = kW x 860 BTU/h = kW x 3,412 cfm = m ³ /min x 35.31 lbs = kg/0.4536
			*The specification data is subject to rounding variation.

1. SPECIFICATIONS

Wall mounted

PKFY-P-VLM-E, VKM-E

Model		PKFY-P50VLM-E	PKFY-P63VKM-E	PKFY-P100VKM-E	
Power source		1-phase 220-240V 50Hz, 1-phase 220-230V 60Hz	1-phase 220-240V 50Hz, 1-phase 220V 60Hz	1-phase 220-240V 50Hz, 1-phase 220V 60Hz	
Cooling capacity (Nominal)	*1 kW	5.6	7.1	11.2	
	*1 kcal / h	4,800	6,100	9,600	
	*1 BTU / h	19,100	24,200	38,200	
	Power input	0.05	0.05	0.08	
(220V)	Current input	A	0.45	0.37	0.58
Heating capacity (Nominal)	*2 kW	6.3	8.0	12.5	
	*2 kcal / h	5,400	6,900	10,800	
	*2 BTU / h	21,500	27,300	42,600	
	Power input	0.04	0.04	0.07	
(220V)	Current input	A	0.40	0.30	0.51
External finish		Plastic, MUNSELL (0.7PB 9.2/0.4)	Plastic, MUNSELL (1.0Y 9.2/0.2)	Plastic, MUNSELL (1.0Y 9.2/0.2)	
External dimension HxWxD		mm	299x898x237	365x1170x295	
		in.	11-25/32 x 35-3/8 x 9-11/32	14-3/8 x 46-1/16 x 11-5/8	14-3/8 x 46-1/16 x 11-5/8
Net weight		kg(lbs)	13(29)	21(46)	21(46)
Heat exchanger		Cross fin (Aluminum fin and copper tube)	Cross fin (Aluminum fin and copper tube)	Cross fin (Aluminum fin and copper tube)	
FAN	Type x Quantity		Line flow fan x 1	Line flow fan x 1	Line flow fan x 1
	External static press.	Pa	0	0	0
		mmH ₂ O	0	0	0
	Motor Type		DC motor	DC motor	DC motor
	Motor output		0.030	0.056	0.056
	Driving mechanism		Direct-driven	Direct-drive	Direct-drive
	Airflow rate (Low-Mid2-Mid-High)	m ³ / min	6.8-8.3-10.2-12.4	16-20	20-26
		L/s	113-138-170-207	267-333	333-433
cfm		240-293-360-438	565-706	706-918	
Sound pressure level (measured in anechoic room)		dB <A>	31-36-41-46	39-45	41-49
Insulation material		Polyethylene sheet	Polyethylene sheet	Polyethylene sheet	
Air filter		PP honeycomb	PP honeycomb	PP honeycomb	
Protection device		Fuse	Fuse	Fuse	
Refrigerant control device		LEV	LEV	LEV	
Connectable outdoor unit		R410A CITY MULTI	R410A CITY MULTI	R410A CITY MULTI	
Diameter of refrigerant pipe	Liquid (R410A)	mm(in.)	6.35(1/4) Flare	9.52(3/8) Flare	9.52(3/8) Flare
	Gas (R410A)	mm(in.)	12.70(1/2) Flare	15.88(5/8) Flare	15.88(5/8) Flare
Field drain pipe size		mm(in.)	I.D. 16(5/8)	I.D. 16(5/8)	I.D. 16(5/8)
Drawing	External		-	-	-
	Wiring		-	-	-
	Refrigerant cycle		-	-	-
Standard attachment	Document		Installation Manual, Instruction Book	Installation Manual, Instruction Book	Installation Manual, Instruction Book
	Accessory		-	-	-
Optional parts	External LEV Box		PAC-SG95LE-E	PAC-SG95LE-E	-
	Drain pump		PAC-SK01DM-E	PAC-SH94DM-E	PAC-SH94DM-E
Remarks		* Details on foundation work, duct work, insulation work, electrical wiring, power source switch, and other items shall be referred to the Installation Manual. * Due to continuing improvement, above specification may be subject to change without notice.			

Notes:	*1 Nominal cooling conditions (subject to JIS B8615-1)	*2 Nominal heating conditions (subject to JIS B8615-1)	Unit converter
	Indoor: 27°C.D.B./19°C.W.B. (81°F.D.B./66°F.W.B.) Outdoor: 35°C.D.B. (95°F.D.B.) Pipe length: 7.5 m (24-9/16 ft.) Level difference: 0 m (0 ft.)	20°C.D.B. (68°F.D.B.) 7°C.D.B./6°C.W.B. (45°F.D.B./43°F.W.B.) 7.5 m (24-9/16 ft.) 0 m (0 ft.)	kcal/h = kW x 860 BTU/h = kW x 3,412 cfm = m ³ /min x 35.31 lbs = kg/0.4536
			*The specification data is subject to rounding variation.

PKFY-P10, 15, 20, 25, 32VLM-E

Unit: mm

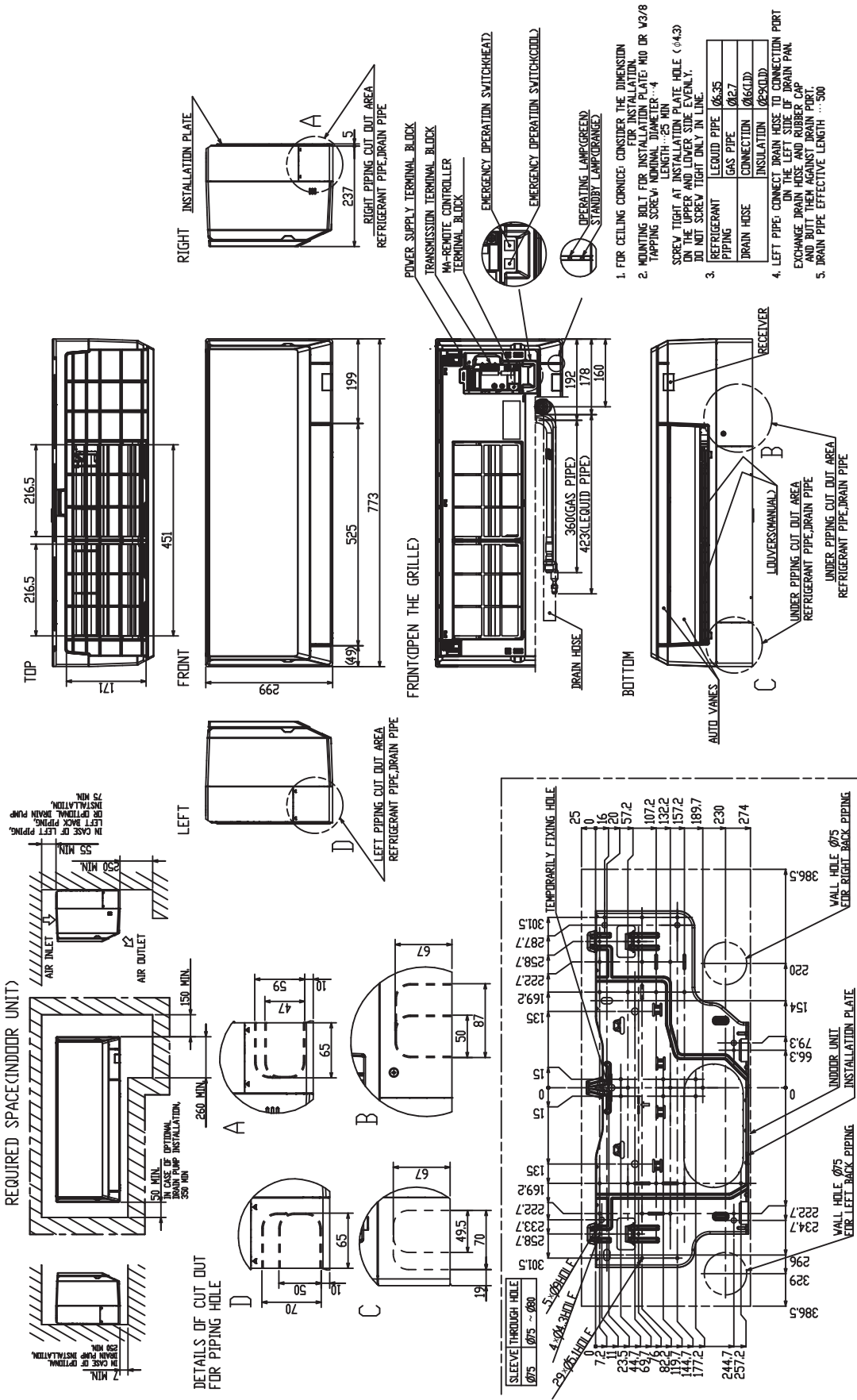

1. FOR CEILING CORNICE: CONSIDER THE DIMENSION FOR INSTALLATION.
2. MOUNTING BOLT FOR INSTALLATION PLATE: M10 OR V3/8 LENGTH: 25 MIN
3. REFRIGERANT PIPING: TAPPING SCREW: NOMINAL DIAMETER: 4
4. LEFT PIPE: CONNECT DRAIN HOSE TO CONNECTION PORT ON THE LEFT SIDE OF DRAIN PAN EXCHANGE DRAIN HOSE AND RUBBER CAP AND BUTT THEM AGAINST DRAIN PORT
5. DRAIN PIPE EFFECTIVE LENGTH: 300

REFRIGERANT PIPING	LIQUID PIPE	Ø6.35
DRAIN HOSE	GAS PIPE	Ø12.7
INSULATION	Ø6.0(Ø)	

PKFY-P-VLM-E, VKM-E

PKFY-P63, 100VKM-E

Unit : mm

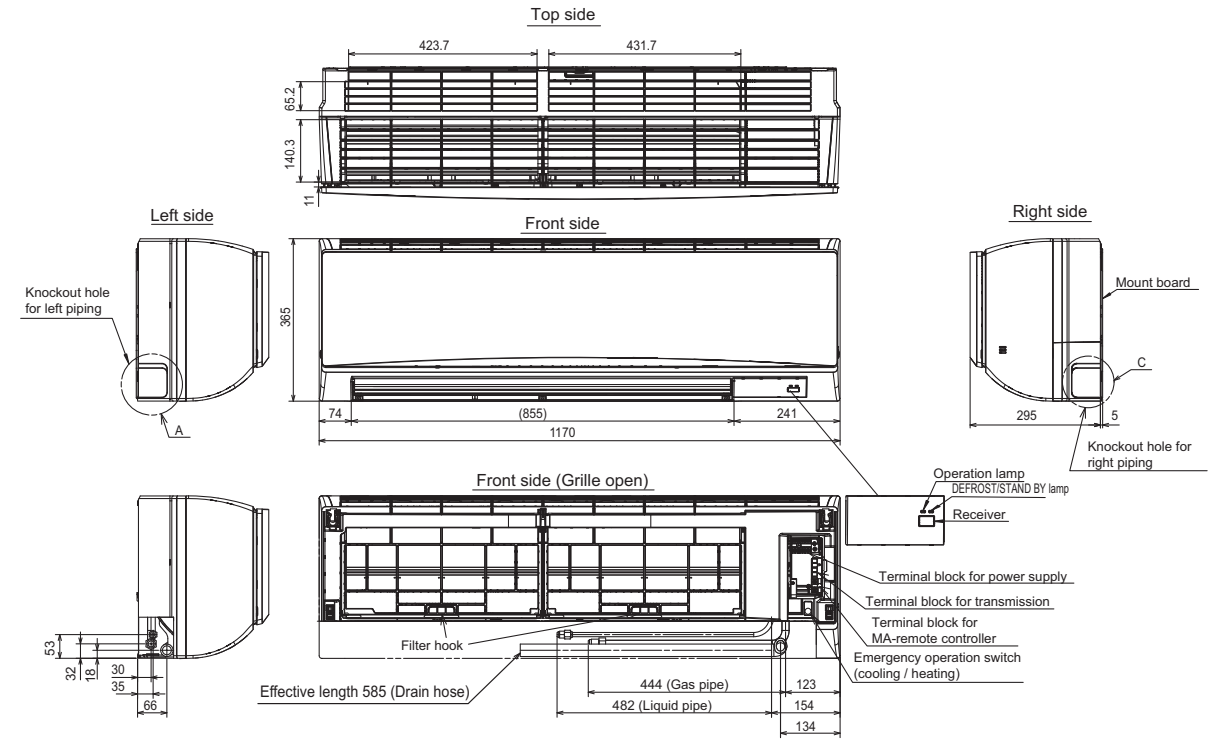

Sleeve (purchased locally)	Through hole
φ75	φ75~φ80

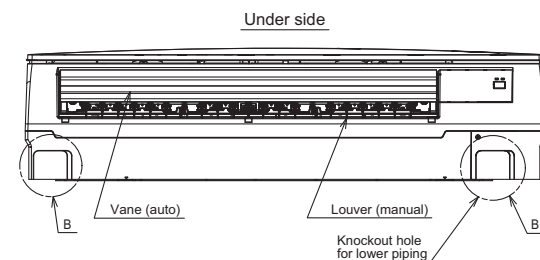

	Size	
	P63	P112
① Liquid pipe	Refrigerant pipe : φ9.52	Flared connection : 3/8F
② Gas pipe	Refrigerant pipe : φ15.88	Flared connection : 5/8F
③ Drain hose	φ16 O.D	

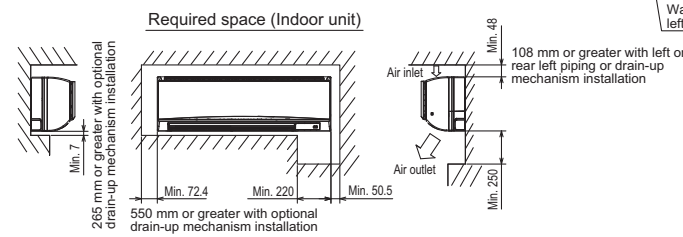
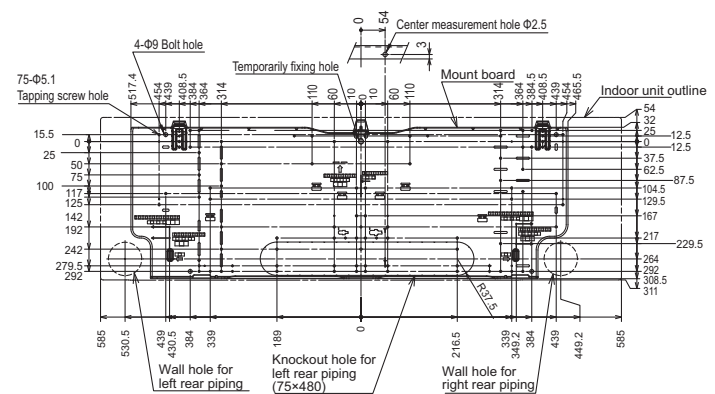
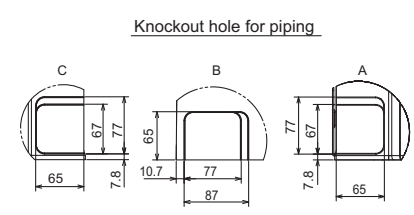

PKFY-P-VLM-E, VKM-E

PKFY-P-VLM-E, VKM-E

PKFY-P-VLM-E, VKM-E

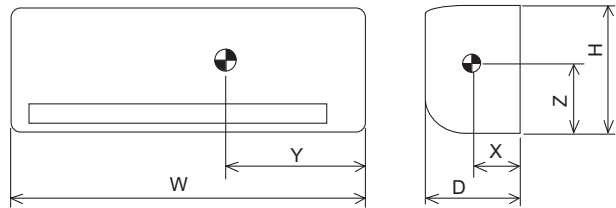

(mm)

Model	W	D	H	X	Y	Z
PKFY-P10VLM-E	773	237	299	130	340	150
PKFY-P15VLM-E	773	237	299	130	340	150
PKFY-P20VLM-E	773	237	299	130	340	150
PKFY-P25VLM-E	773	237	299	130	340	150
PKFY-P32VLM-E	773	237	299	130	340	150
PKFY-P40VLM-E	898	237	299	120	390	150
PKFY-P50VLM-E	898	237	299	120	390	150
PKFY-P63VKM-E	1170	295	365	190	460	190
PKFY-P100VKM-E	1170	295	365	190	460	190

PKFY-P10, 15, 20, 25, 32, 40, 50VLM-E

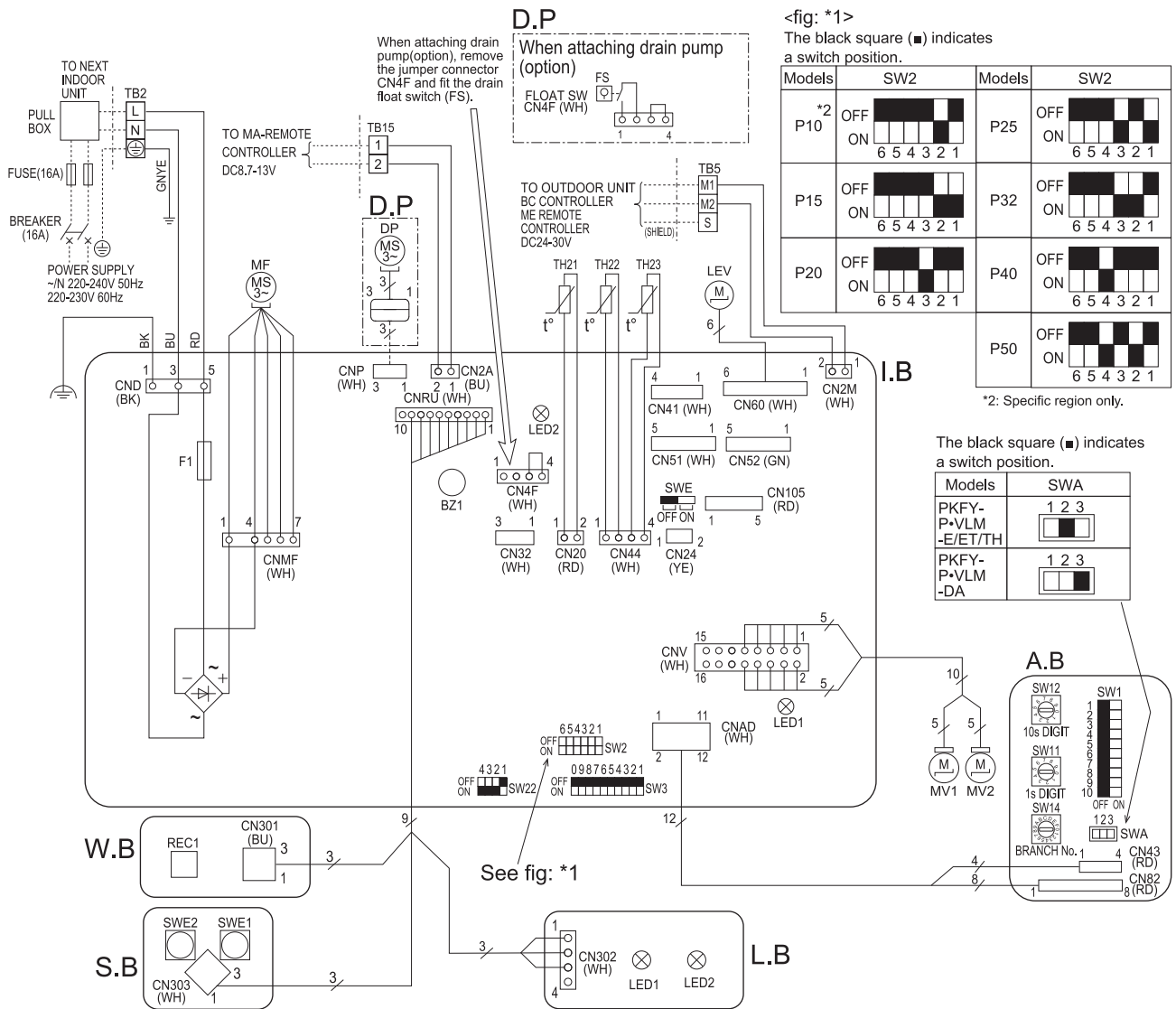

SYMBOL	NAME	SYMBOL	NAME
I.B	INDOOR CONTROLLER BOARD	TH21	THERMISTOR ROOM TEMP. DETECTION (0°C/15kΩ, 25°C/5.4kΩ)
CN32	CONNECTOR REMOTE SWITCH	TH22	PIPE TEMP. DETECTION / LIQUID (0°C/15kΩ, 25°C/5.4kΩ)
CN51	CENTRALLY CONTROL	TH23	PIPE TEMP. DETECTION / GAS (0°C/15kΩ, 25°C/5.4kΩ)
CN52	REMOTE INDICATION		
CN105	IT TERMINAL	A.B	ADDRESS BOARD
BZ1	BUZZER	SWA	SWITCH REGION SELECTION
F1	FUSE (T3,15AL250V)	SW1	SWITCH MODE SELECTION
LED1	POWER SUPPLY (I.B)	SW11	SWITCH ADDRESS SETTING 1s DIGIT
LED2	POWER SUPPLY (MA-REMOTE CONTROLLER)	SW12	SWITCH ADDRESS SETTING 10s DIGIT
SW2	SWITCH CAPACITY CODE	SW14	SWITCH BRANCH No.
SW3	SWITCH MODE SELECTION	S.B	SWITCH BOARD
SW22	SWITCH PAIR NO. SETTING	SWE1	SWITCH EMERGENCY OPERATION(HEAT)
SWE	SWITCH FAN-DRAIN PUMP (TEST MODE)	SWE2	SWITCH EMERGENCY OPERATION(COOL)
LEV	LINEAR EXPANSION VALVE	W.B	PCB FOR WIRELESS REMOTE CONTROLLER
MF	FAN MOTOR	REC1	RECEIVING UNIT
MV1	VANE MOTOR (UPPER)	L.B	LED BOARD
MV2	VANE MOTOR (LOWER)	LED1	LED(OPERATING INDICATOR:GREEN)
TB2	TERMINAL POWER SUPPLY	LED2	LED(STANDBY FOR HEATING : ORANGE)
TB5	BLOCK TRANSMISSION	D.P	DRAIN PUMP KIT (OPTION)
TB15	BLOCK MA-REMOTE CONTROLLER	FS	DRAIN FLOAT SWITCH
		DP	DRAIN PUMP

NOTES:

1. At servicing for outdoor unit, always follow the wiring diagram of outdoor unit.
2. In case of using MA-Remote controller, please connect to TB15. (Remote controller wire is non-polar.)
3. In case of using M-NET, please connect to TB5. (Transmission line is non-polar.)
4. Symbol [S] of TB5 is the shield wire connection.
5. Symbols used in wiring diagram above are, [] : terminal block, [] : connector.
6. The setting of the SW2 dip switches differs in the capacity. For the detail, refer to the fig : *1.

LED on indoor controller board for service

Symbol	Meaning	Function
LED1	Main power supply	Main power supply (Indoor unit:220-240V) Power on → Lamp is lit
LED2	Power supply for MA-Remote controller	Power supply for MA-Remote controller on → Lamp is lit

PKFY-P63, 100VKM-E

SYMBOL	NAME	SYMBOL	NAME
I.B	INDOOR CONTROLLER BOARD	TH21	THERMISTOR ROOM TEMP. DETECTION (0°C/15kΩ, 25°C/5.4kΩ)
CN32	CONNECTOR REMOTE SWITCH	TH22	PIPE TEMP. DETECTION / LIQUID (0°C/15kΩ, 25°C/5.4kΩ)
CN51	CENTRALLY CONTROL	TH23	PIPE TEMP. DETECTION / GAS1 (0°C/15kΩ, 25°C/5.4kΩ)
CN52	REMOTE INDICATION	TH24	PIPE TEMP. DETECTION / GAS2 (0°C/15kΩ, 25°C/5.4kΩ)
CN100	IT TERMINAL	A.B	ADDRESS BOARD
BZ1	BUZZER	SWA	SWITCH FAN SPEED SELECTOR
FUSE	FUSE (T3.15AL 250V)	SW1	MODE SELECTION
LED1	POWER SUPPLY(I.B)	SW11	ADDRESS SETTING 1s DIGIT
LED2	POWER SUPPLY(I.B)	SW12	ADDRESS SETTING 10ths DIGIT
SW2	SWITCH CAPACITY CODE	SW14	BRANCH No.
SW3	MODE SELECTION	S.B	SWITCH BOARD
SW4	MODEL SELECTOR	SWE1	EMERGENCY OPERATION(HEAT)
SWE	DRAIN PUMP(TEST MODE)	SWE2	EMERGENCY OPERATION(COOL)
X1	AUX.RELAY DRAIN PUMP(OPTION)	W.B	PCB FOR WIRELESS REMOTE CONTROLLER
LEV	LINEAR EXPANSION VALVE	LED1	LED(OPERATION INDICATOR:GREEN)
MF	FAN MOTOR	LED2	LED(PREPARATION FOR HEATING : ORANGE)
MV	VANE MOTOR	RU	RECEIVING UNIT
TB2	TERMINAL POWER SUPPLY	DP	DRAIN PUMP (OPTION)
TB5	BLOCK TRANSMISSION	FS	DRAIN FLOAT SWITCH (OPTION)
TB15	MA-REMOTE CONTROLLER		

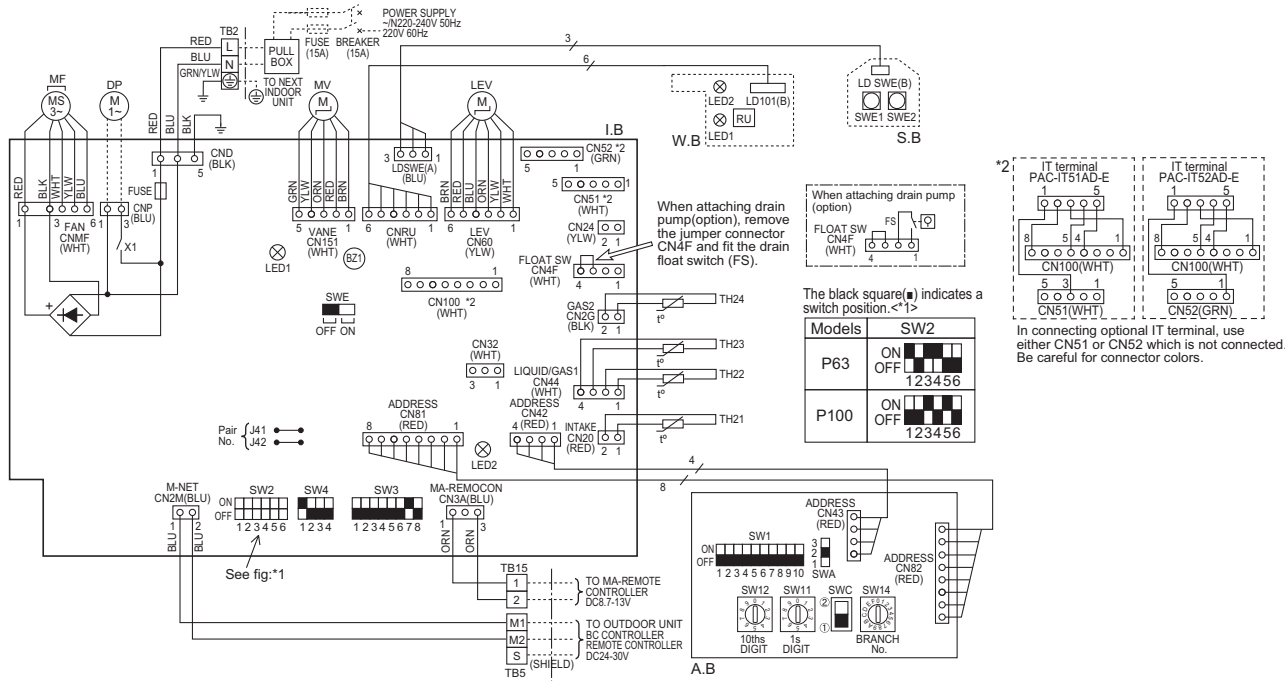

NOTES:

- At servicing for outdoor unit, always follow the wiring diagram of outdoor unit.
- In case of using MA-Remote controller, please connect to TB15. (Remote controller wire is non-polar.)
- In case of using M-NET, please connect to TB5. (Transmission line is non-polar.)
- Symbol [S] of TB5 is the shield wire connection.
- Symbols used in wiring diagram above are, : terminal block, : connector.
- The setting of the SW2 dip switches differs in the capacity. For the detail, refer to the fig.*1.

LED on indoor board for service

Mark	Meaning	Function
LED1	Main power supply	Main power supply (Indoor unit:220-240V) Power on → lamp is lit
LED2	Power supply for MA-Remote controller	Power supply for MA-Remote controller on → lamp is lit

5-1. Sound levels

Wall mounted

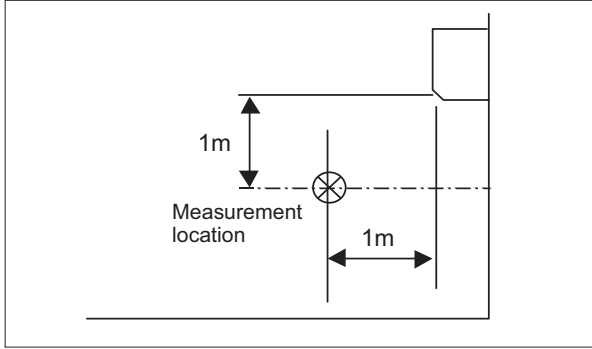

Sound level at anechoic room: Low-(Middle2-Middle)-High

Model	Sound level dB (A)
PKFY-P10VLM-E	22-24-26-28
PKFY-P15VLM-E	22-24-26-28
PKFY-P20VLM-E	22-26-29-31
PKFY-P25VLM-E	22-27-31-35
PKFY-P32VLM-E	24-31-37-41
PKFY-P40VLM-E	29-34-37-40
PKFY-P50VLM-E	31-36-41-46
PKFY-P63VKM-E	39-45
PKFY-P100VKM-E	41-49

* Measured in anechoic room.

5-2. NC curves

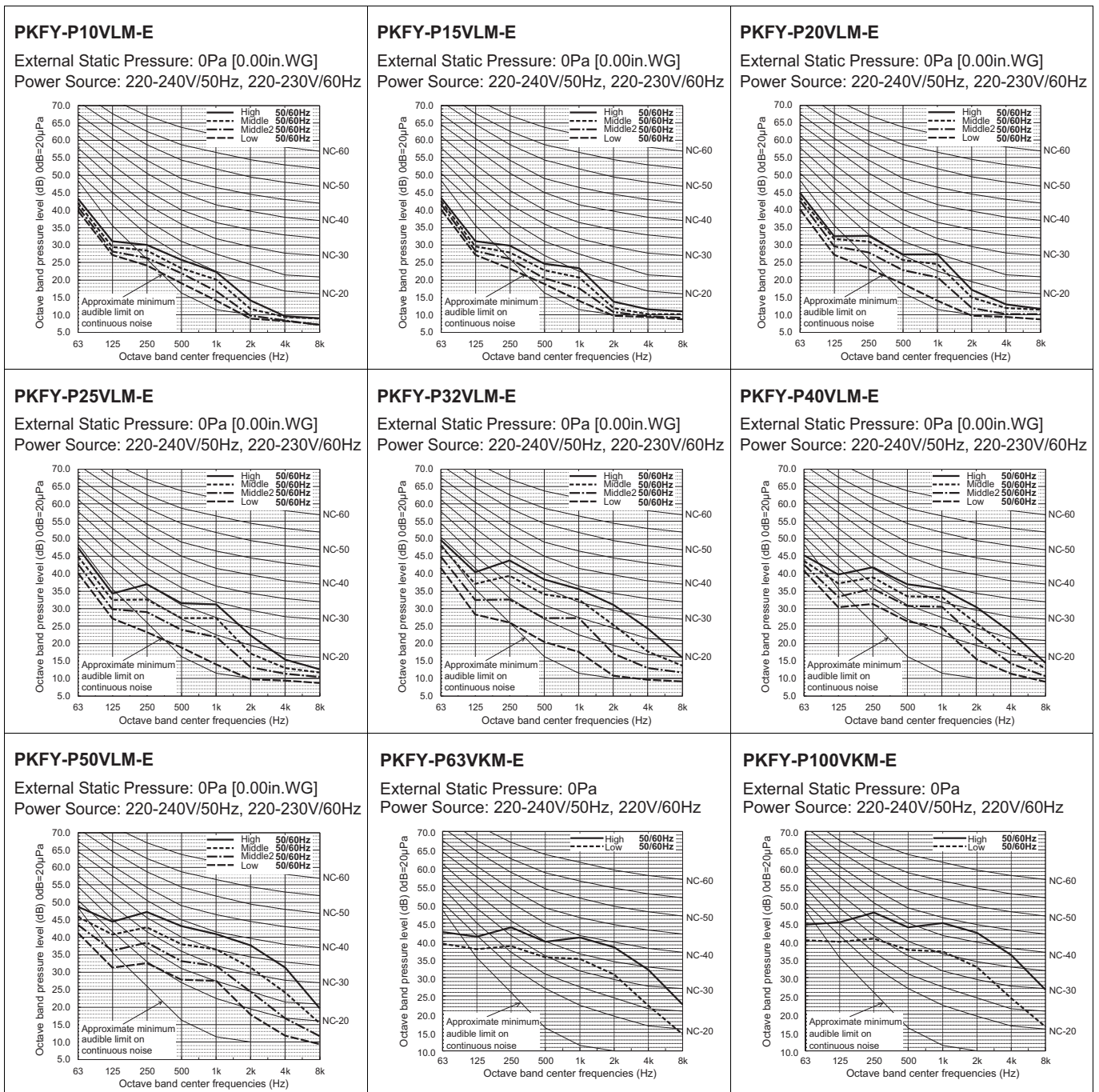

6-1. Temperature distributions

PKFY-P-VLM-E, VKM-E

PKFY-P32VLM-E

<Cooling mode>

Horizontal air flow

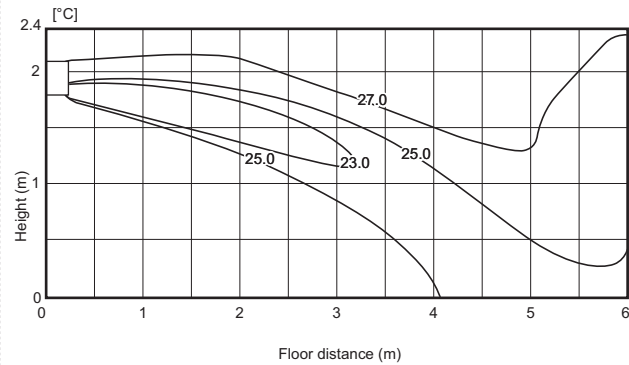

<Heating mode>

Downward air flow

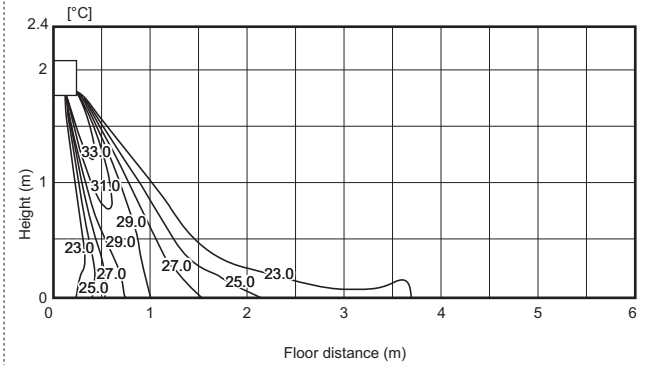

PKFY-P50VLM-E

<Cooling mode>

Horizontal air flow

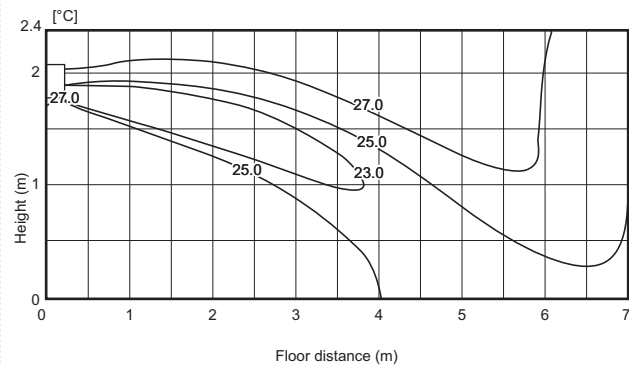

<Heating mode>

Downward air flow

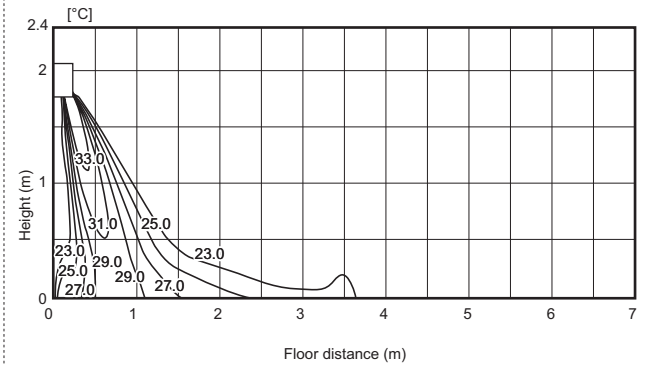

PKFY-P63, 100VKM-E

<Cooling mode>

Horizontal air flow

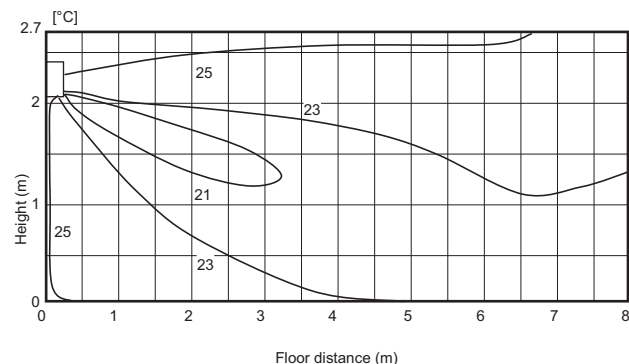

<Heating mode>

Downward air flow

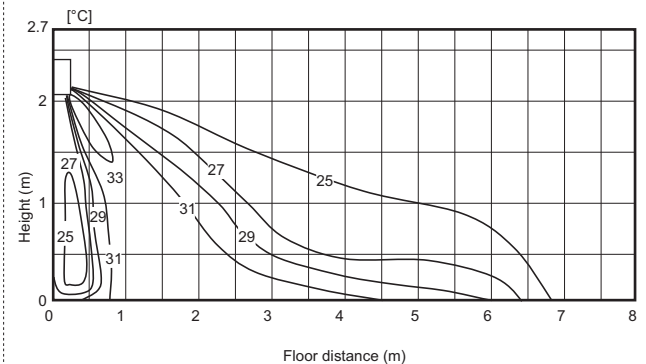

Note : These figures show typical temperature distributions in the conditions above. In the actual installation, they may differ from these figures under the influence of air temperature conditions, ceiling height, cooling/heating load, obstacles, etc.

6-2. Airflow distributions

PKFY-P32VLM-E

<Cooling mode>
Horizontal air flow

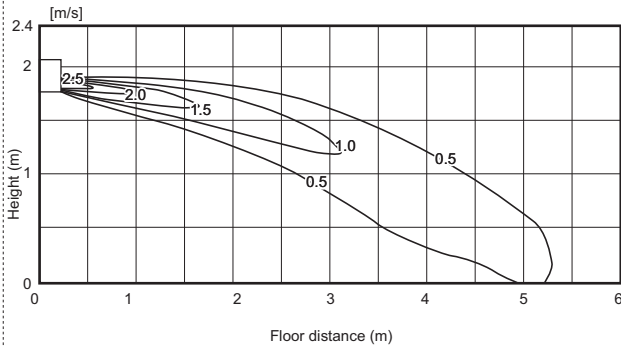

<Heating mode>
Downward air flow

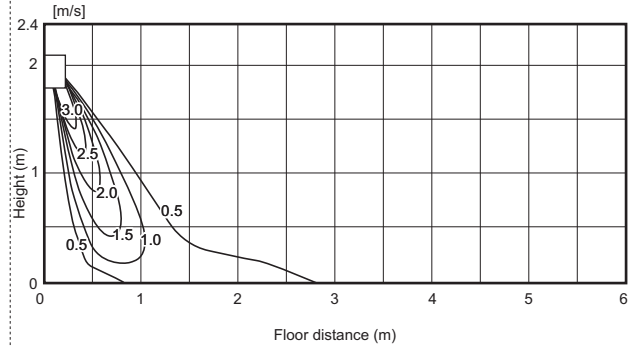

PKFY-P50VLM-E

<Cooling mode>
Horizontal air flow

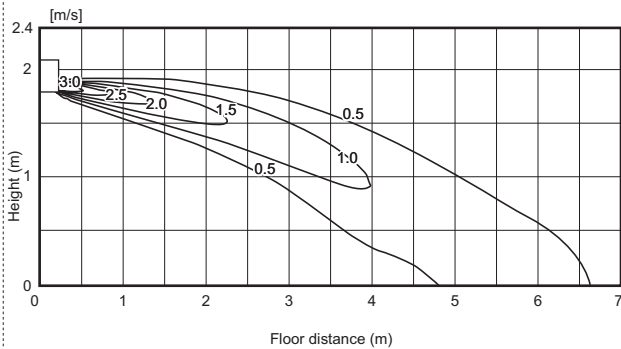

<Heating mode>
Downward air flow

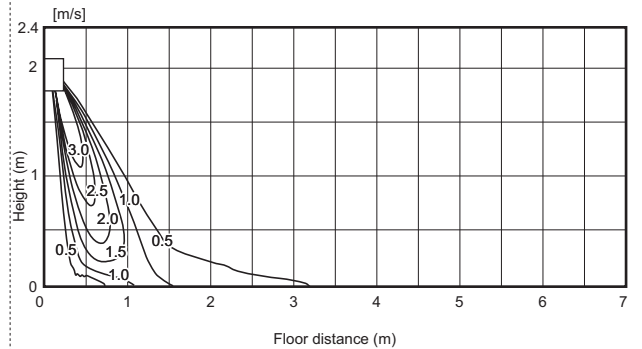

PKFY-P63, 100VKM-E

<Fan mode>
Horizontal air flow

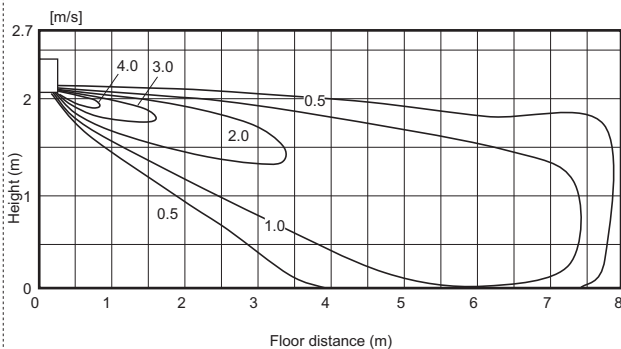

<Fan mode>
Downward air flow

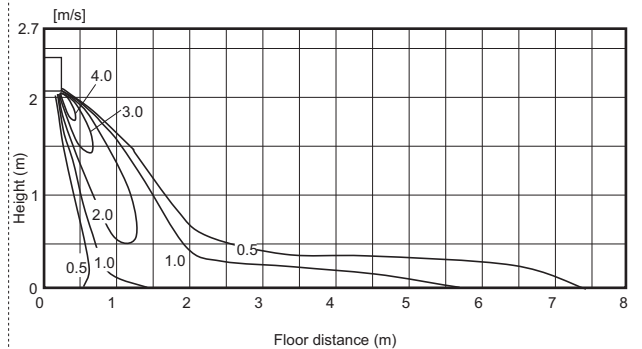

Note : These figures show typical airflow distributions in the conditions above. In the actual installation, they may differ from these figures under the influence of air temperature conditions, ceiling height, cooling/heating load, obstacles, etc.

7. ELECTRICAL CHARACTERISTICS

Wall mounted

Symbols: MCA (Max.Circuit Amps =1.25xFLA), FLA (Full Load Amps)
IFM (Indoor Fan Motor), Output (Fan motor rated output)

PKFY-P-VLM-E	Power supply			IFM	
	Volts/Hz	Range +-10%	MCA(A)	Output (kW)	FLA(A)
PKFY-P10VLM-E	220-240V/50Hz 220-230V/60Hz	Max.: 264V Min.: 198V	0.25	0.030	0.20
PKFY-P15VLM-E			0.25	0.030	0.20
PKFY-P20VLM-E			0.25	0.030	0.20
PKFY-P25VLM-E			0.32	0.030	0.25
PKFY-P32VLM-E			0.44	0.030	0.35
PKFY-P40VLM-E			0.44	0.030	0.35
PKFY-P50VLM-E			0.57	0.030	0.45

PKFY-P-VKM-E	Power supply			IFM	
	Volts/Hz	Range +-10%	MCA(A)	Output (kW)	FLA(A)
PKFY-P63VKM-E	220-240V/50Hz	Max.: 264V	0.36	0.056	0.29
PKFY-P100VKM-E	220V/60Hz	Min.: 198V	0.63	0.056	0.50

PKFY-P-VLM-E, VKM-E

8-1. Optional parts line up for the Indoor unit

	External LEV Box	Drain pump
PKFY-P10VLM-E	PAC-SK17LE-E	PAC-SK01DM-E
PKFY-P15, 20, 25, 32, 40, 50VLM-E	PAC-SG95LE-E	PAC-SK01DM-E
PKFY-P63, 100VKM-E	PAC-SG95LE-E (For P63 only)	PAC-SH94DM-E

8-2. External LEV Box

PAC-SK17LE-E

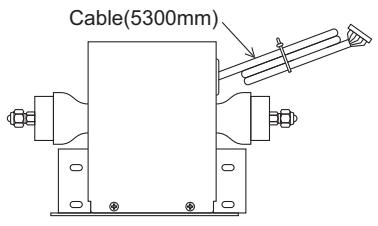
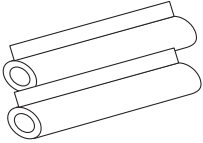
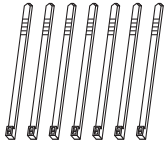
Item	① External LEV Box	② Pipe cover	③ Band
Quantity	1	2	7
Shape			

Detailed installation information should be referred to its Installation Manual.

PAC-SG95LE-E

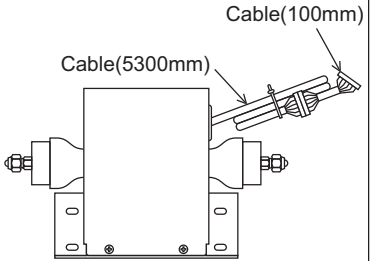
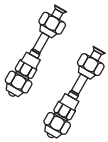
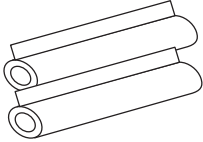
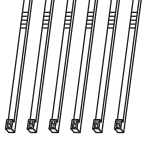
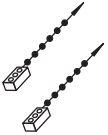

Item	① External LEV Box	② Joint pipe	③ Pipe cover	④ Band	⑤ Fastener
Quantity	1	2	2	6	2
Shape					

Detailed installation information should be referred to its Installation Manual.

8-3. Drain pump

PAC-SK01DM-E

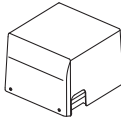

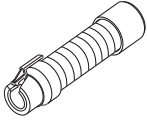
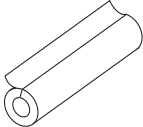
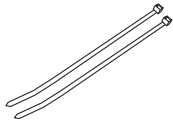
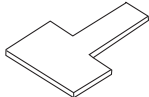
If drain water can not flow out the Indoor unit by gravity and gradient, a Drain-pump for draining is needed.
Drain pump PAC-SK01DM-E can pump water up to 850mm high from the drain pan.

Item	① Drain pump	② Screw	③ Drain hose	④ Flexible hose cover	⑤ Band
Quantity	1	(M4×16)×1, (M4×35)×6	1	1	2
Shape					
Item	⑥ Paper gauge				
Quantity	1				
Shape					

Detailed installation information should be referred to its Installation Manual.

PAC-SH94DM-E

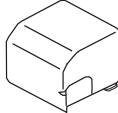
If drain water can not flow out the Indoor unit by gravity and gradient, a Drain-pump for draining is needed.
Drain pump PAC-SH94DM-E can pump water up to 800mm high from the drain pan.

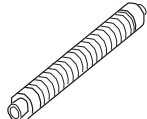
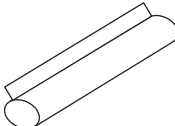
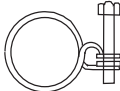
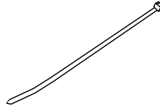
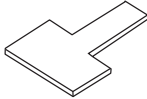
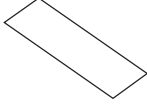
Item	① Drain pump	② Screw	③ Drain hose	④ Drain hose cover	⑤ Hose band
Quantity	1	(M4×16)×1, (M4×35)×6	1	1	1
Shape					
Item	⑥ Band	⑦ Installation plate	⑧ Wiring diagram		
Quantity	1	1	1		
Shape					

Detailed installation information should be referred to its Installation Manual.



for a greener tomorrow

Eco Changes is the Mitsubishi Electric Group's environmental statement, and expresses the Group's stance on environmental management. Through a wide range of businesses, we are helping contribute to the realization of a sustainable society.

⚠ Warning

- Do not use refrigerant other than the type indicated in the manuals provided with the unit and on the nameplate.
 - Doing so may cause the unit or pipes to burst, or result in explosion or fire during use, repair, or at the time of disposal of the unit.
 - It may also be in violation of applicable laws.
 - MITSUBISHI ELECTRIC CORPORATION cannot be held responsible for malfunctions or accidents resulting from the use of the wrong type of refrigerant.
- Our air conditioning equipment and heat pumps contain a fluorinated greenhouse gas, R410A.

MITSUBISHI ELECTRIC CORPORATION

www.MitsubishiElectric.com