



Advanced Test Equipment Rentals
www.atecorp.com 800-404-ATEC (2832)

OLYMPUS ZOOM STEREO MICROSCOPE

MODEL SZ-III
REPAIR MANUAL

OLYMPUS

PREFACE

1. It is generally considered very difficult to achieve optical alignment of a zoom stereomicroscope. In comparison with Olympus Stereo Microscopes such as Model VT-II, VB, etc., the zoom stereo microscope Model SZ-III is complicated in its structure, but not so such in its optical alignment. If you master the optical alignment of this microscope, other Olympus stereo microscopes become easier to you.

It is recommended to pay careful attention to the checking order as described in "II. CHECK POINTS". This order should be kept in the alignment procedure.

For instance, if you observe a double image through the binocular observation tube, points 1, 3 and/or 5 are/is involved. In case two or more points are involved, their alignment order should not be changed. If you check the optical alignment in the order of 3, 1 and 5, you have to repeat the alignment in the order of 1, 3 and 5.

2. Requisites for Repairs

A lot of screws used in microscopes have been cemented in position with various adhesives to prevent them from loosening in transit, operation, etc. If it is necessary to remove screws for repair, look at their heads and ascertain whether they are cemented with what kind of adhesive. You may be able to identify adhesives by their outside coloring and choose the best way to remove.

- a. "ARALDITE", tinted with white and translucent, requires heating before loosening screws with a screwdriver.
- b. "NEJI-LOCK" is slightly red. Screws cemented with "NEJI-LOCK" are removable with a screwdriver. If not, apply heat slightly before unscrewing.
- c. "SHELLAC" is brown. Shellacked screws are removable with a screwdriver. If not, moisten them with alcohol.
- d. "HIGH SUPER" (cemedine), tinted with white, requires heating before loosening screws.
- e. "PLIOBOND", sober yellow, requires a small amount of mixture (alcohol and ether) to loosen screws.

Others:

- (1) First of all, ascertain what parts of the microscope the user or owner of which wishes you to repair.
- (2) Never fail to check the entire function of the microscope before you commence its repair.
 - 1) Find out what parts are defective and how much they are damaged.
 - 2) Prior to repair, think of the best possible order of disassembling the defective parts in a most efficient way.
 - 3) After completing the repair, check the functions of not only the re-assembled parts but also the entire microscope to make sure no defect should be left unremedied.
 - 4) Be careful not to deform repair parts during the assembly; make the point of using tools and jigs specified for purpose.
 - 5) Make repairs promptly and accurately.

Diagram of Optical System

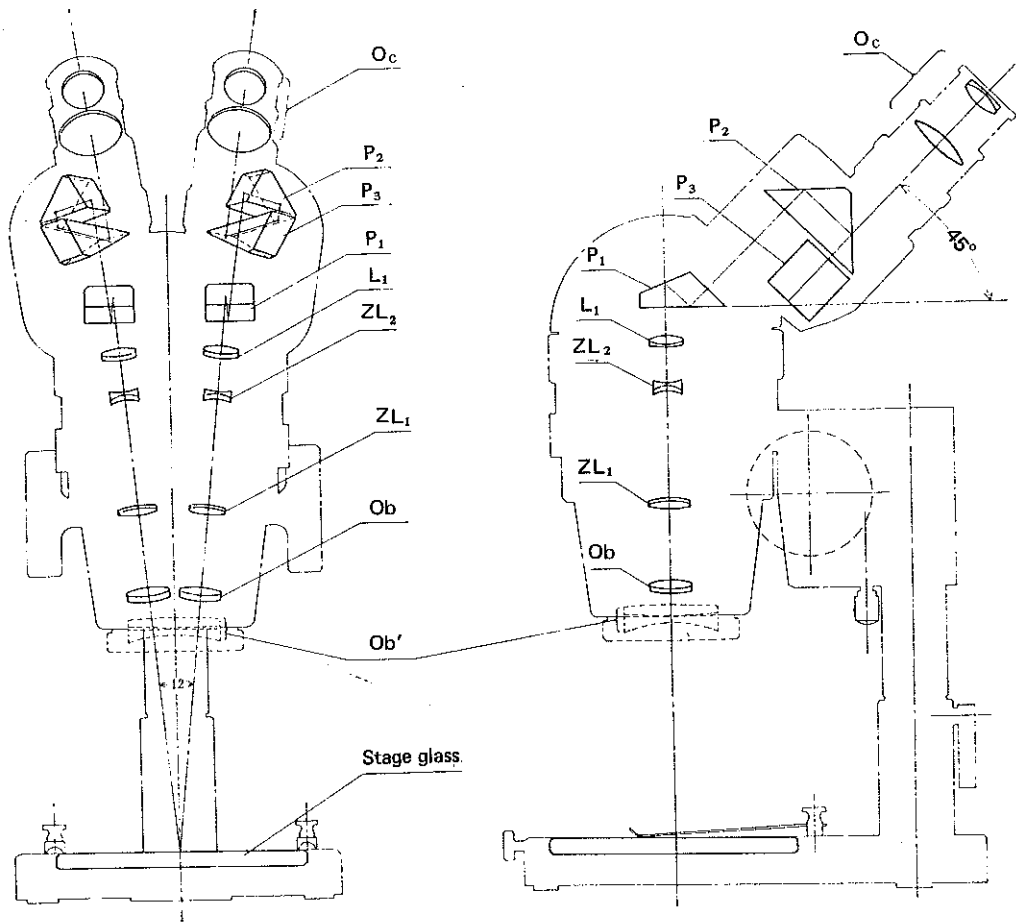

Model SZ

1. REPAIR TOOLS

C-2:	Eyepiece with cross hairs G10X	(for centration)
Regular eyepiece:	G10X	(for parfocality checks)
C-15:	Focusing magnifier PM-FT	(for parfocality checks)
KN0003:	Test plate with 5/100 concentric circles	
OT0011:	Screwdrives (set of 6 pcs.)	
OT0261:	Others: Hexagonal wrench	
OT1131:	Adhesive "LAC"	
OT0022:	Adjustable spanner (blade tip)	

2. CHECK POINTS

Order	Check	Description
1	Decentration of image at various interpupillary distances	Decentration of image should be corrected on right and left optical systems respectively.
2	Deterioration of focus when zooming	After focusing at high magnification, shift of focus when zooming to low magnification should be adjusted on the right and left hand optical systems, respectively.
-3	Decentration of image when zooming	After centration of image at high magnification, shift of image when zooming to low magnification should be adjusted on the right and left optical systems respectively.
4	Parfocality between right hand and left hand optical systems	After centration of image in the left hand optical system, shift of focus in the right hand optical system should be corrected.
5	Centration of right hand and left hand optical systems	After centration of image in the right hand optical system, decentration of the left hand optical system should be corrected.

3. ALIGNMENT PROCEDURE

Check Points	Working Steps	Tools
1. Decentration of image at various interpupillary distances	1) This alignment should be carried out in the same order of steps on the right and left hand optical systems, respectively.	<ul style="list-style-type: none"> o Test plate (5/100 concentric circles)

- 2) After coinciding the centers of the cross hairs and concentric circles, change the interpupillary of the center of the concentric circles.

- o G10X with cross hairs
- o Screwdrivers

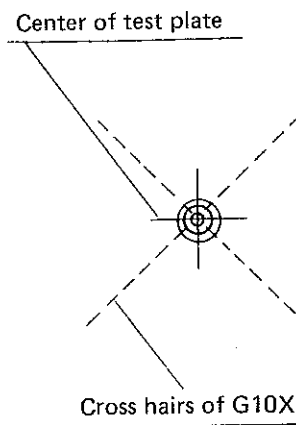

Fig. 1 Maximum interpupillary distance

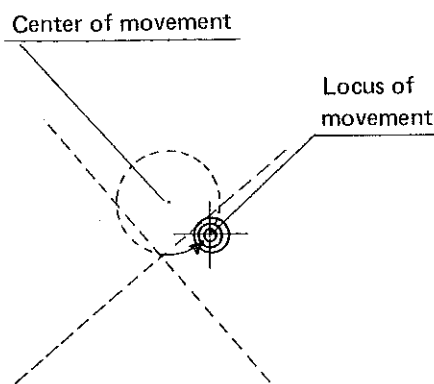
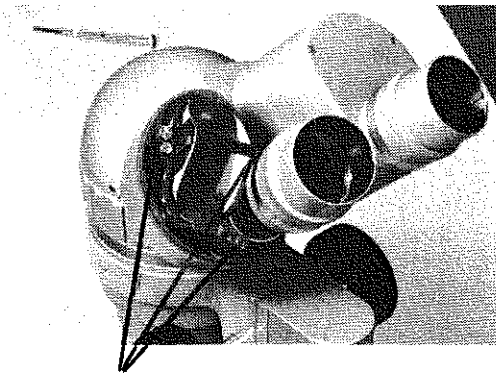

Fig. 2 Minimum interpupillary distance

- 3) If the center of the concentric circles moves in the direction of the arrow in Fig. 2, determine the center of rotation from the locus of

its movement. (the image moves around this center.)

- 4) After determination of the center of rotation, take the steps below:
 1. Remove eyepiece sleeves (AA072300, ZJ826800).
 2. Remove two screw (AA072000) and cover of prism housing (AA071900).
 3. Replace eyepiece sleeve.
 4. Loosen three CUK3 x 14SA screws and move prism P2 and prism mount AA068100 together until the centers of the cross hairs and concentric circles are coincident.



CMK3 x 14SA

Fig. 3

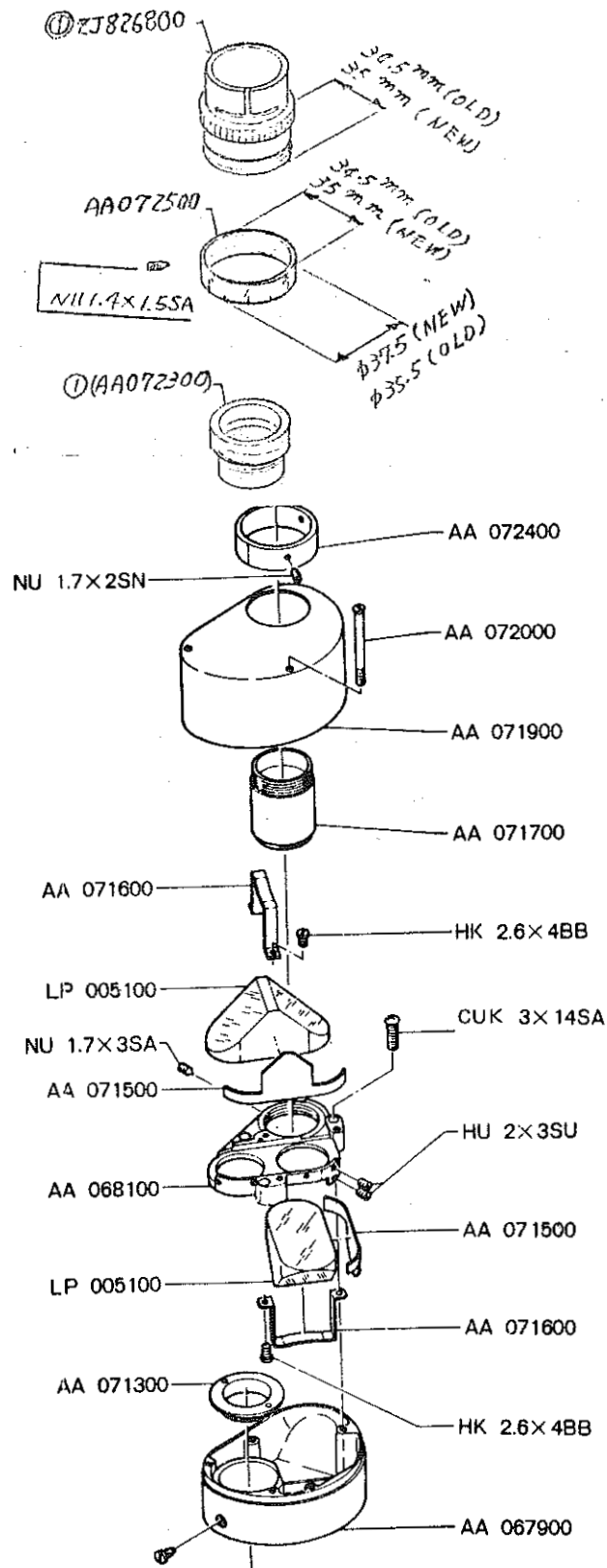

OLD PARTS ARE NO LONGER
 AVAILABLE.
 NEW PARTS ARE AVAILABLE
 PARTS ASSEMBLY (ZJ826800)
 WITH GRADUATED RING
 (AA072500).

- 5) After adjusting the prism P2, tighten the screws and check the centration in step 2).
- 6) Repeat the steps above until centration is complete.
- 7) Completing the alignment, secure the screws with a small amount of adhesive "LAC".
- 8) Replace prism housing cover.

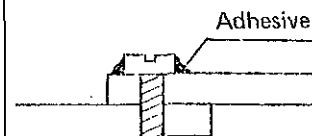

2. Deterioration of focus when zooming

- 1) Remove observation cover (AA072800). (Fig. 4)



Fig. 4

- A. Disassembly order of parts concerned with this alignment is as follows:
 - a. Loosening two set screws (3PUK 1.7 x 3SA), remove the observation tube cover (AA072800).
 - b. Loosening one AB4 x 10SP and two AB4 x 8SB screws, remove the observation tube (AA067700).
 - c. Loosening three set screws (HK2.6-146SA), remove the magnification ring (AA068400).
 - d. Remove the objective shroud (AA072900), rotating it counterclockwise.
 - B. Remount the observation tube on the microscope.
- 2) Align the right and left hand optical systems, respectively.
 - 3) Focus at highest magnification using eyepiece G10X and focusing magnifier PM-FT. (Ascertain that the helicoid ring of the observation tube is set at position "O".)

- o G10X
- o Test plate (5/100 concentric circles)
- o Focusing magnifier PM-FT
- o Screwdrivers
- o Hexagonal wrench

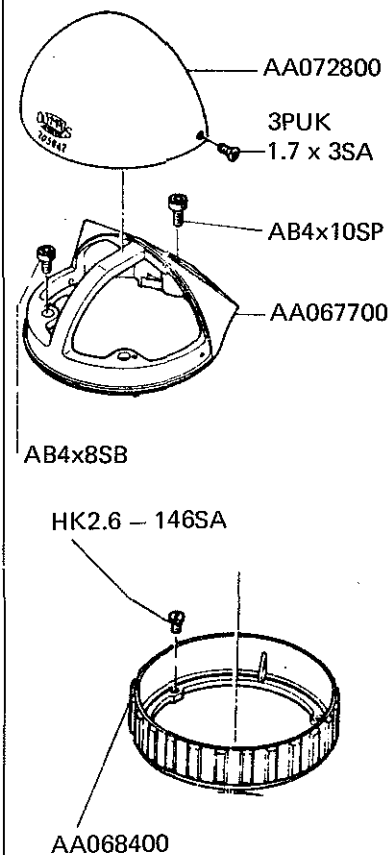

o Use of Focusing Magnifier PM-FT

1. Olympus eyepieces are corrected for two different diopters, regardless of magnifications. One type is corrected for -1 diopter, the other for -4 diopter. They can be identified by external appearances as illustrated below:

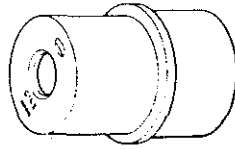

-1 diopter eyepiece
(currently used)

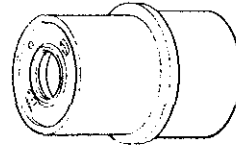

-4 diopter eyepiece
(old type)

These illustrations above represent the eyepiece G10X for stereo microscopes.

The -1 diopter eyepiece has a plain front surface, while the -4 diopter eyepiece has a recess on the front surface.

2. Focusing with Focusing Magnifier PM-FT

- A. In case of -1 diopter eyepieces:

Looking through the magnifier, move the eyepiece portion in or out until an object $1,000$ mm away from the magnifier is brought into focus.

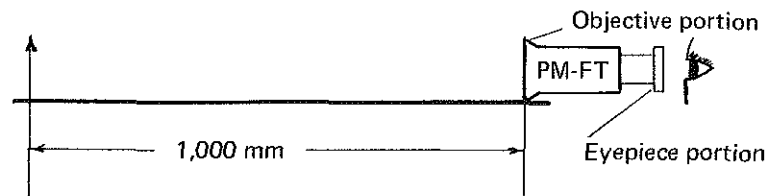

Fig. 5

- B. In case of -4 diopter eyepieces:

Place an object 250 mm away from the PM-FT and focus it in the same manner as with the -1 diopter eyepiece.

- 4) Place the PM-FT on the eyepiece of the microscope and, focusing at highest magnification, zoom to lowest magnification.
- 5) If image of specimen goes out of focus at lowest magnification, rotate the helicoid ring of the observation tube until the image is refocused.
- 6) During the rotation of the helicoid, confirm the direction of the rotation and read the amount of upward displacement of the helicoid (the helicoid rotates in the + direction), or downward displacement (the helicoid rotates in the - direction) on the scale engraved on the helicoid. (Fig. 6).
- 7) In case the helicoid moves upward (in the + direction):

- o Parts to align:

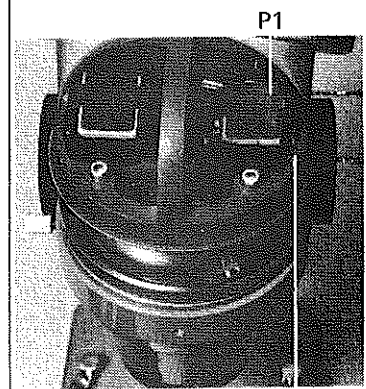

Frame
of L1

Fig. 6

This alignment is carried out by vertical movement of lens L1, beneath prism P1.

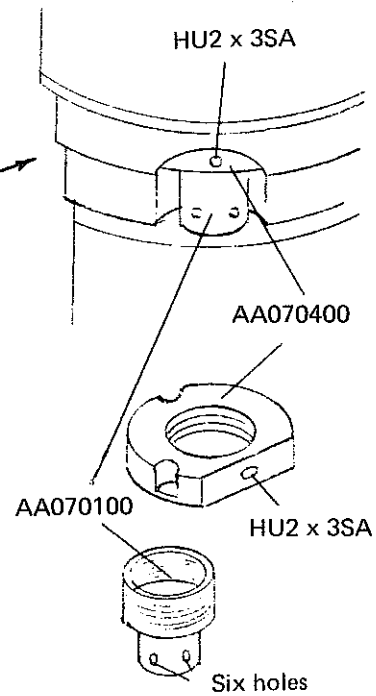
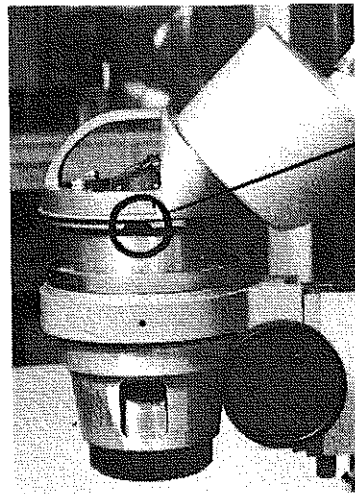

Fig. 7

- a. Loosen HU2 x 3SA screw as shown in the picture above.
 - b. After loosening HU2 x 3SA screw, lens L1 can be moved.
 - c. Rotate the lower part of lens L1 by successively inserting shank of small screwdriver into any one of six holes in lens mount, in such a way that the lens moves out.
As lens L1 rotate 360°, the helicoid can be adjusted by one increment on the scale.
 - d. Tighten HU2 x 3SA.
- 8) Completing the steps above, check the focus. If the focus is not correct, repeat steps 4) to 7).

NOTE:

Take extreme care not to scratch the lens surface.

NOTE:

If helicoid moves in (– direction), rotate lens L1 in reverse.

- Test plate
- G10X with cross hairs
- Screwdriver

3. Decentration of image when zooming

- 1) Coincide the centers of the cross hairs of G10X and concentric circles of the test plate, at maximum zoom position.

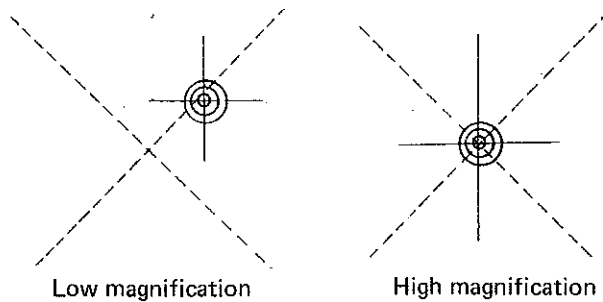

Fig. 8

- 2) Zoom to minimum zoom position and check for decentration of the centers.
- 3) If the center moves, adjust the lens frame AA070400 accordingly.
 - a. Loosen two HK2.6–346SA screws at the lens frame, but not completely. (Fig. 9)

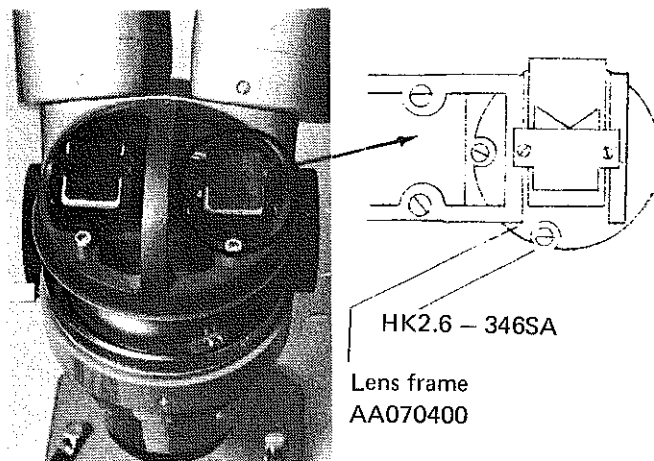

Fig. 9

NOTE:

It is recommended to loosen these screws in a manner that they permit the lens frame to move only little by little as you insert a small screwdriver into one of the screw holes in the lens frame and tap it from backward slightly.

- b. Align the lens frame.
- c. Completing the adjustment at minimum magnification, zoom the magnification to maximum, and repeat steps 1) and 2) to confirm image centration.
- d. Repeat the steps above until the adjustment is complete.

NOTE:

The image moves in a direction opposite to the moving direction of the lens frame.

- 4) Finally tighten screws and cement with adhesive.

4. Parfocality between right hand and left hand optical systems

- 1) Looking through the left eyepiece, focus at high magnification.
 - a. For this adjustment, ascertain that the helicoid is positioned at "O".
 - b. Use the PM-FT magnifier.
- 2) Re-insert eyepiece G10X into right observation tube.

- G10X
- Test plate
- Screwdrivers
- Adjustable spanner
- PM-FT
- Adhesive

- 3) Use PM-FT magnifier to confirm focus.
- 4) If image is out of focus, adjust helicoid of observation tube until it is in focus and check direction of helicoid movement in the + or – direction.
- 5) Focus can be adjusted by moving the objective in or out.

Fig. 10 shows the objectives as viewed from beneath. The objective (right) can be moved in or out with its thread.

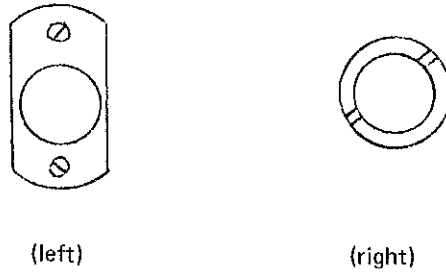

Fig. 10

- 6) If helicoid rotates in the + direction, adjust right objective to move inwards.
- 7) If helicoid rotates in the – direction, adjust right objective to move outwards.
- 8) Repeat above steps until alignment is complete.
- 9) Cement screws with adhesive.

5. Centration of right hand and left hand optical systems

- 1) Looking through right eyepiece, coincide centers of cross hairs and concentric circles.

- o G10X with cross hairs
- o Test plate
- o Screwdrivers
- o Adhesive

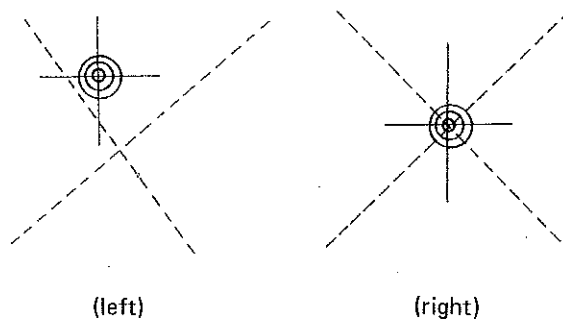

Fig. 11

	<p>2) Re-insert eyepiece into left eyepiece tube. If decentration is observed through left eyepiece, take the following steps:</p> <ol style="list-style-type: none"> a. Loosen two HK2-375BB screws that clamp the left objective. b. Center objective within the limit permitted by looseness between objective and its setscrews. c. After centration, do not move objective when tightening the screws. <p>3) Check and adjust, following steps 1) and 2) repeatedly.</p> <p>4) After completing adjustment, cement screws with adhesive.</p>	<p>The method for this step is same as in step 3.3) a.</p>
<p>6. Final check</p>	<p>Double check steps 1 to 5.</p>	

Refer to the Repair Manual X-II for the repair of the coarse adjustment mechanism.

MEMO

MEMO

**Progress
through
Precision**

OLYMPUS OPTICAL CO., LTD.

43-2, Hatagaya, 2-chome, Shibuya-ku, Tokyo, Japan

OLYMPUS OPTICAL CO. (EUROPA) GMBH.

2 Hamburg 1, Steindamm 105, West Germany

OLYMPUS CORPORATION OF AMERICA

4 Nevada Drive, New Hyde Park, N. Y. 11042, U.S.A.