



Model S-100 Floor Scale



Operation Manual

©Avery Weigh-Tronix, LLC. All rights reserved.

The information contained herein is the property of Avery Weigh-Tronix and is supplied without liability for errors or omissions. No part may be reproduced or used except as authorised by contract or other written permission. The copyright and the foregoing restriction on reproduction and use extend to all media in which the information may be embodied.

Salter Brecknell is a trading name of Avery Weigh-Tronix LLC

WARNINGS

Safe installation Safety



THE EQUIPMENT CONTAINS NO USER SERVICEABLE COMPONENTS.

Installation and maintenance of the equipment must only be carried out by trained and authorised personnel.

Electrical installation

The mains lead must be connected to a supply outlet with a protective earth contact. The electrical supply at the socket outlet must provide over current protection of an appropriate rating.

For your protection all mains (110V or 230V) equipment used out of doors or in wet or damp conditions should be supplied from a correctly fused source and protected by an approved ground fault protection device (RCD, GFCI etc.)

IF IN DOUBT SEEK ADVICE FROM A QUALIFIED ELECTRICIAN.



Routine maintenance

To avoid the possibility of electric shock or damage to the machine, always switch off the machine and isolate from the power supply before carrying out any routine maintenance.

To avoid the risk of the machine falling, where applicable, ensure that it is placed securely on a flat and level surface.

Safe use

Caution – Cleaning the indicator/weigh head

Harsh abrasives, solvents, scouring cleaners and alkaline cleaning solutions, such as washing soda, should not be used especially on the display windows. Under no circumstances should you attempt to wipe the inside of the machine.

The outside of standard products may be wiped down with a clean cloth, moistened with water containing a small amount of washing up liquid.

The outside of products waterproofed to IP65, IP66 and IP67 may be washed down with water containing a small amount of proprietary detergent.

Training

Do not attempt to carry out any procedure on a machine unless you have received the appropriate training or read the Instruction Manual.

EMC compliance

The following may be applicable to your machine.

WARNING:

This is a class A product. In a domestic environment this product may cause radio interference in which case the user may be required to take adequate measures.

Contents

WARNINGS	2
Product Identification Table	3
ASSEMBLY	4
Product Contents.....	4
Setting the Indicator Up for Use.....	4
Wire the cable attached to the base as shown (if necessary).....	4
Indicator and Platform Assembly.....	5
Display and Keypad.....	6
Manual symbols.....	6
Scale Operation	7
Turning On and Zeroing the Scale.....	7
Selecting Unit of Measure.....	7
Using the Tare.....	7
Hold function with automatic zero on next weigh.....	8
Hold function with manual release.....	8
Removing Hold.....	8
Print Function.....	8
USER CONFIGURATION SETTINGS	9
Setup Controls.....	9
Entering setup.....	9
User Configuration Settings.....	10
RS-232 data commands for SBI protocol.....	11
Other RS-232 Output Strings.....	12
RS232 serial interface wiring.....	12
Scale calibration	13
Calibration Configuration Settings –.....	13
Factory Calibration Settings shown in bold.....	13
Calibration Menu	14
Service Configuration Settings	15
Technical Specifications	16
Error Messages	16
Declarations of Compliance	17
Contact Information & Technical Support.....	17

Product Identification Table

Part Number	Capacity	Region	Power Supply (s)
816965001620	75 kg x 0.01kg / 150lb x 0.02lb	North America	US Version, UL
816965001637	150 kg x 0.02kg / 300lb x 0.05lb	North America	US Version, UL
816965001644	300 kg x 0.05kg / 600lb x 0.1lb.	North America	US Version, UL
816965002160	75 kg x 0.01kg / 150lb x 0.02lb.	UK/EU	3 pin UK & 3 pin EU ,CE approved
816965002177	150 kg x 0.02kg / 300lb x 0.05lb.	UK/EU	3 pin UK & 3 pin EU ,CE approved
816965002184	300 kg x 0.05kg / 600lb x 0.1lb.	UK/EU	3 pin UK & 3 pin EU ,CE approved
816965002719	75 kg x 0.01kg / 150lb x 0.02lb.	AUS/SA	3-pin Australia C-Tick approved, 3 pin South Africa
816965002726	150 kg x 0.02kg / 300lb x 0.05lb.	AUS/SA	3-pin Australia C-Tick approved, 3 pin South Africa
816965002733	300 kg x 0.05kg / 600lb x 0.1lb.	AUS/SA	3-pin Australia C-Tick approved, 3 pin South Africa

ASSEMBLY

Product Contents

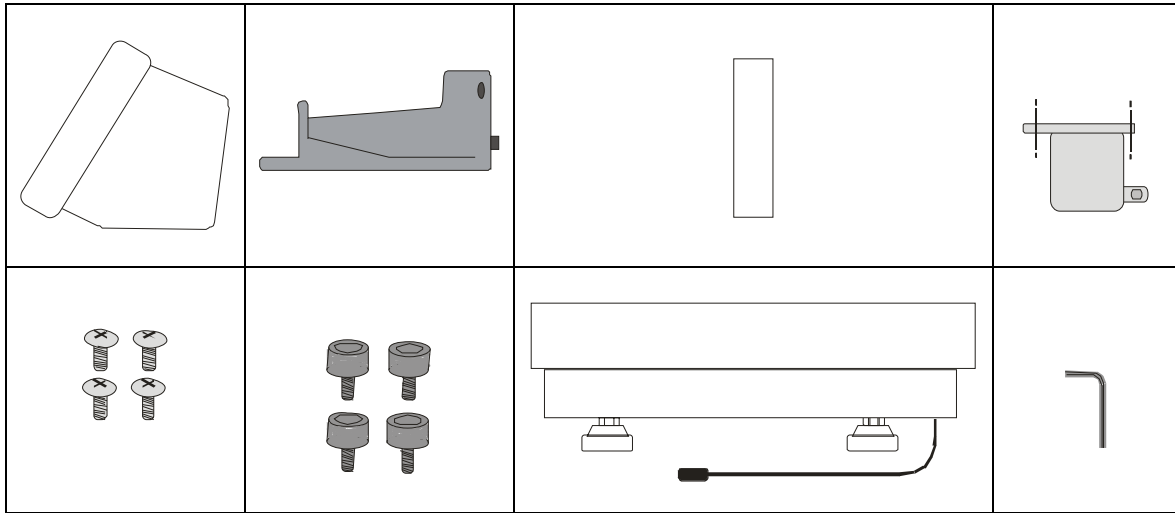

Setting the Indicator Up for Use

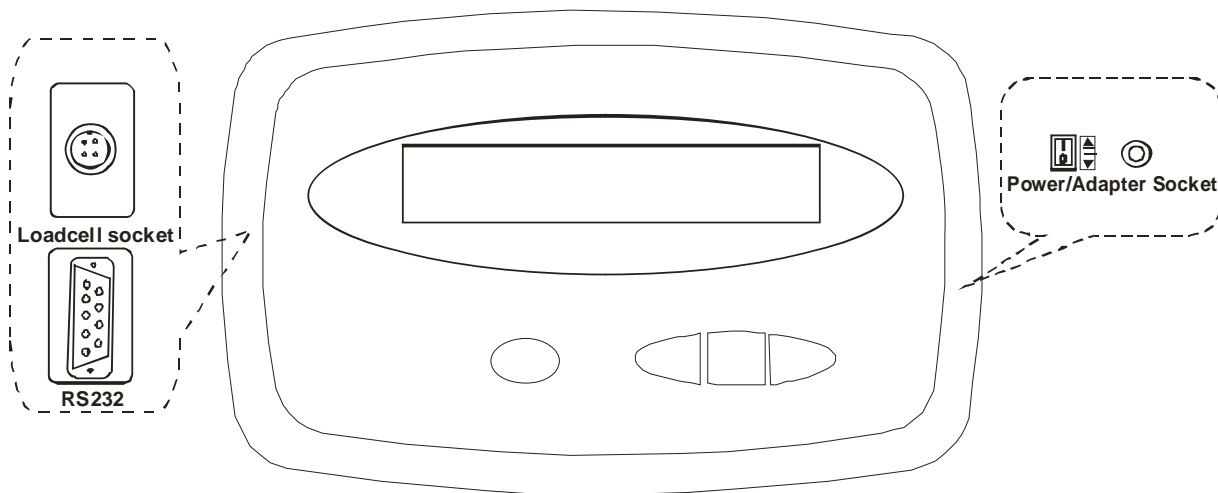

Power Supply

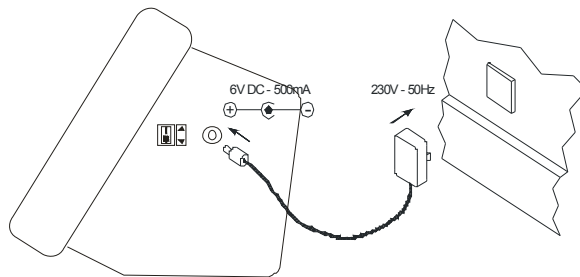

Connecting the Indicator to the Platform

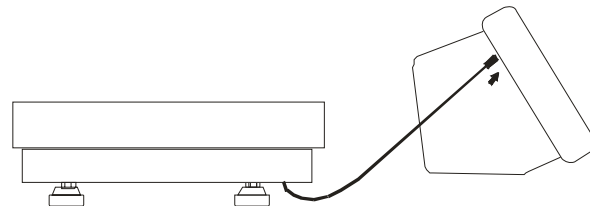

Wire the cable attached to the base as shown (if necessary)



Indicator and Platform Assembly

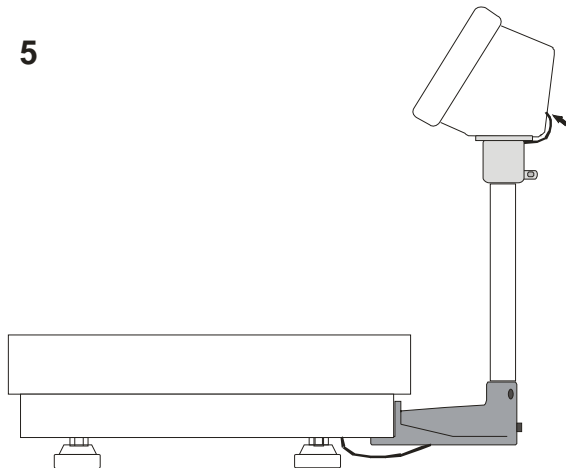
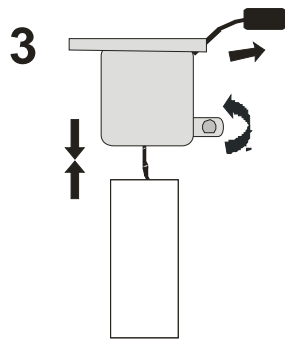
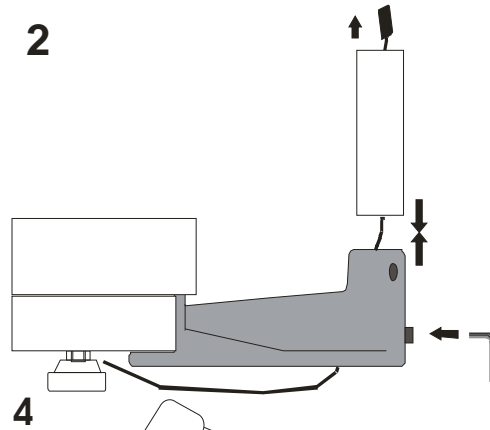
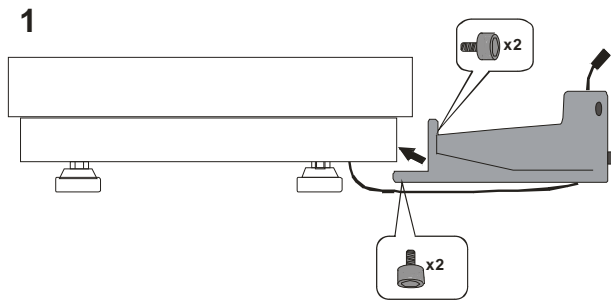
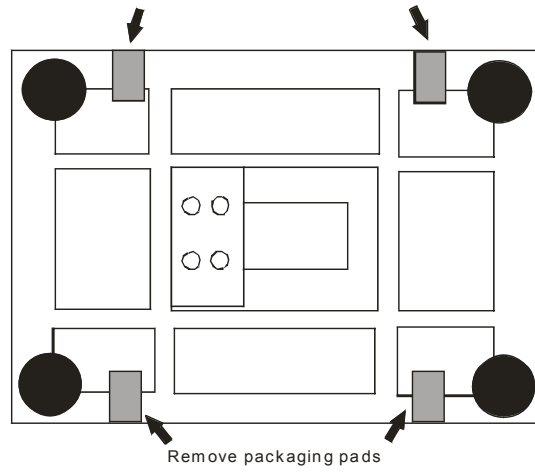

Display and Keypad

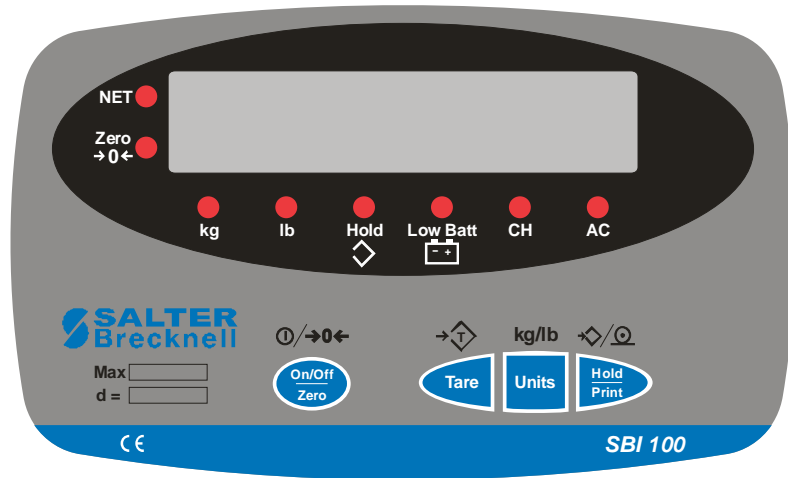

Function Keys	Annunicators
 Tare	NET ● Tare is activated
 On/Off/Zero	Zero ● Weight is zero
kg/lb Units Unit of measurement	kg ● lb ● Unit of measure (Flashing LED means that the weight reading is not stable.)
 Hold/Print	CH ● Battery is charging.
	AC ● Adapter is plugged in.
	Hold ● Hold is activated
	Low Batt ● Battery is low.

Manual symbols



Short Key Press



Multiple Key Press



Long key press

Scale Operation

Turning On and Zeroing the Scale

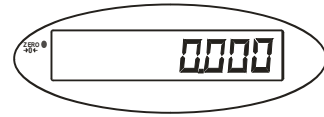
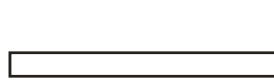

Turning off the scale

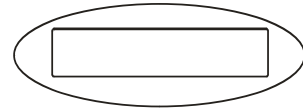

Selecting Unit of Measure

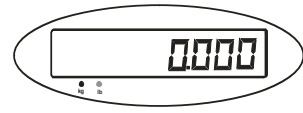
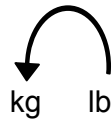

Using the Tare

1.

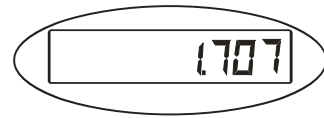
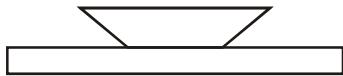

2.



3.

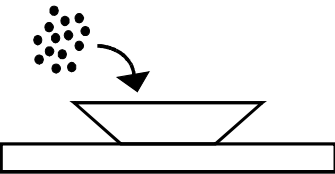

4.

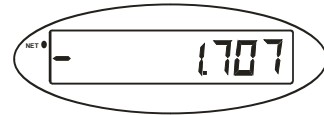
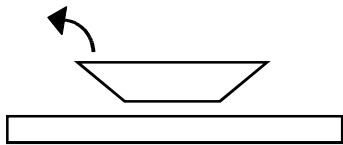

Removing the Tare

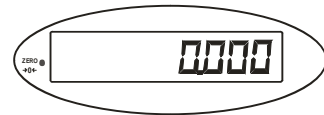
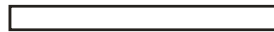

Hold function with automatic zero on next weigh.

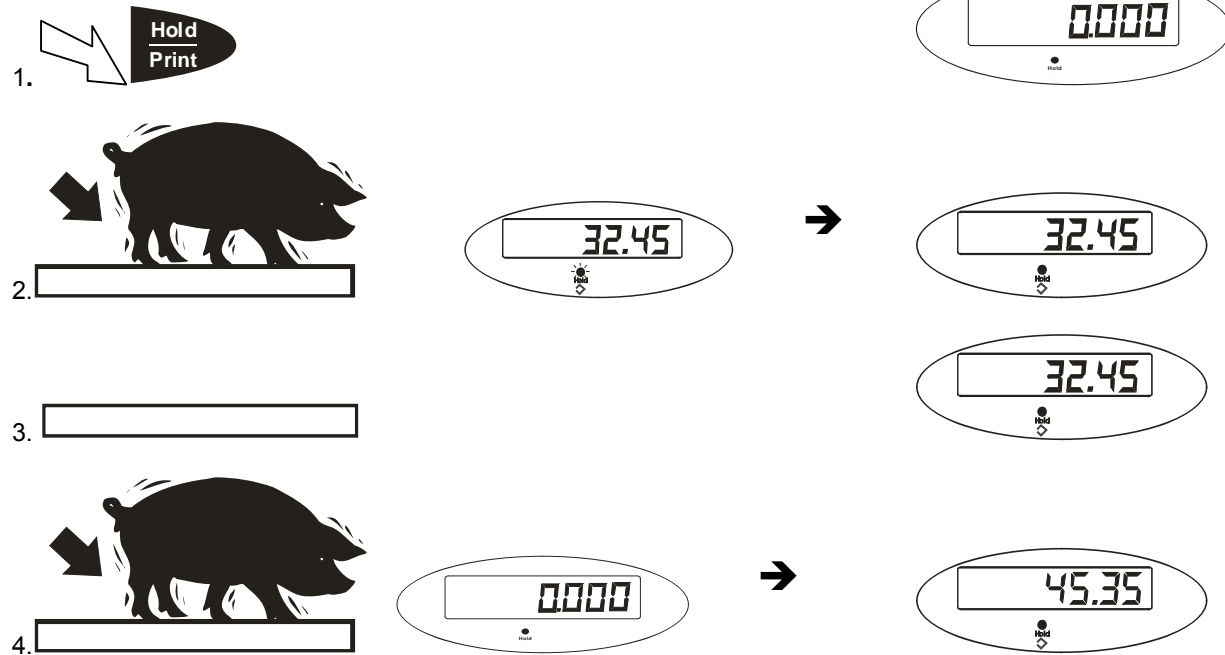

Hold function with manual release.

This function needs to be setup in Parameter P3.1 shown on page 10

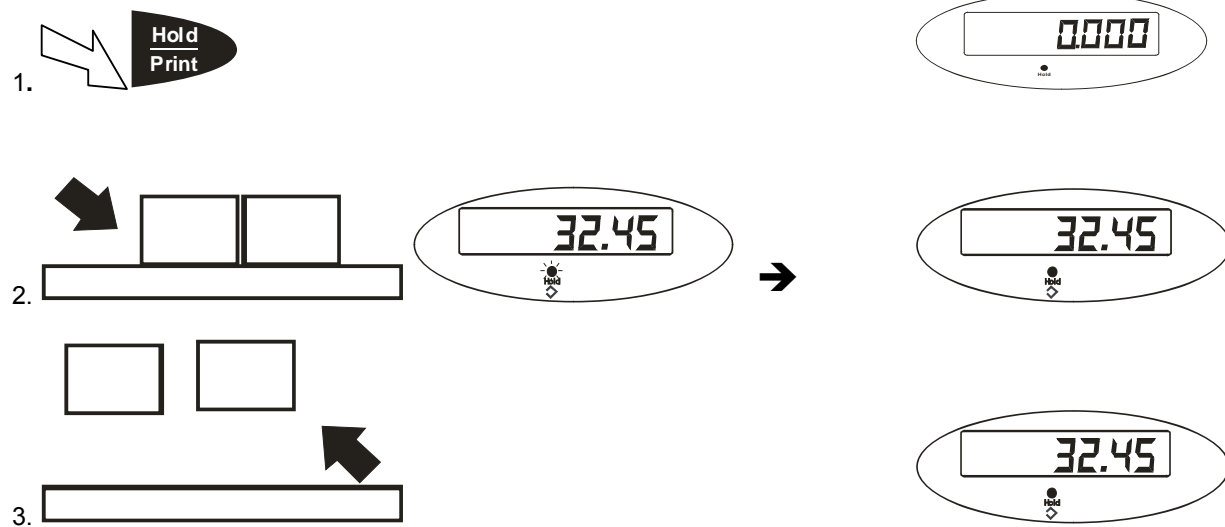

Removing Hold



Print Function

For communications to a printer or PC, the indicator has to be setup in the following parameters P2, P4, P5 and P6.

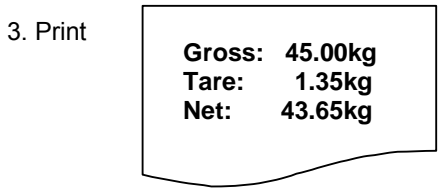
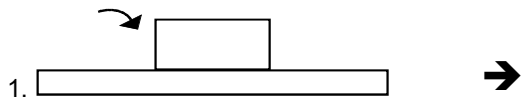

USER CONFIGURATION SETTINGS

Setup Controls

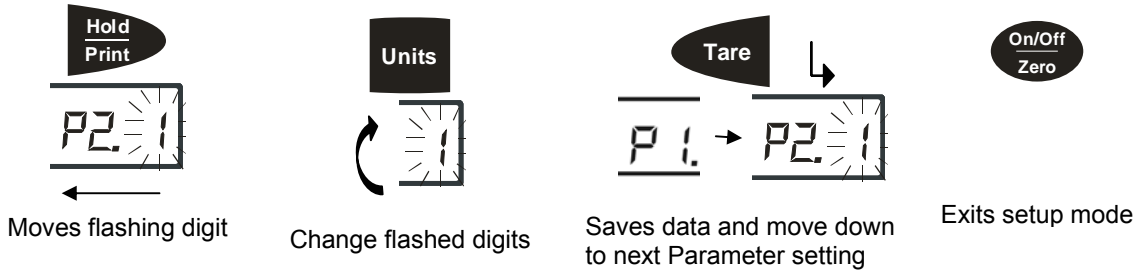

Entering setup



Selecting parameter



Changing data within the parameter



Saving data

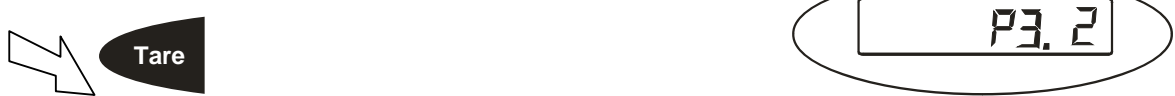

Exiting setup



User Configuration Settings

Parameter	Setting	Default settings in bold
P1.xy	Auto shutoff timer in minutes <i>Set up time for the auto off function.</i> (00 = Off, 01-15 = time in minutes)	P1.00 P1.01 – P1.15, P1.5 = 15 minutes
P2.x	Hold and print key functionality <i>Setup button function</i> 0 = Press button once to activate hold 1= Press button once to print 2= Press button to print/Press and hold button to activate hold.	P2.0= Hold P2.1= Print; P2.2= Print & Hold,
P3.xy	Hold Function Settings 0= <u>No hold function active.</u> 1= <u>Averaging hold with manual push button release.</u> The weight reading will be held on the display until a higher weight is applied, this will automatically release the held weight and re-hold it at the new higher weight reading. 2= <u>Averaging hold with automatic release and re-hold.</u> As above but The weight reading will be held on the display until the platform is emptied and the next weight reading over 10divisions is applied. 3-50= <u>Selectable hold window from +/- 3 to 50 divisions</u> Will hold display reading once stable within a selectable weight range, to release the hold button must be represses..	P3.0 P3.1 P3.2 P3.3 to 50
P4.x	RS232 – Serial Interface <i>Settings for serial interface</i> 0= No RS232 output 1= Print displayed data once stable when print key is pressed; 2= Print gross, tare and net weight once stable when print key is pressed 3= Continuously output gross weight 4= Continuously output gross, tare and net weight 5= Print displayed data once stable one time only. 6= Print gross, tare and net weight once stable, one time only. 7= Bidirectional - RS232, SBI protocol	P4.0 P4.1 P4.2 P4.3 P4.4 P4.5 P4.6 P4.7
P5.x	RS232 Baud rate	P5.0= 1200 P5.3= 9600 P5.1= 2400 P5.4= 19200 P5.2= 4800
P6.x	RS232 Data format 0 = 8 digits, no odd or even, 1 start bit, 1 stop bit 1 = 7 digits, 1 even, 1 start bit , 1 stop bit 2 = 7 digits, 1 odd, 1 start bit, 1 stop bit 3 = 8 digits, no parity, 1 start bit, 1 stop bit	P6. 0 P6. 1 P6. 2 P6. 3
P7-P19 .x	SERVICE CONFIGURATIONS ONLY <i>Any adjustment to these settings could seriously affect the indicators performance. Seek advice from a service engineer before changing.</i>	

RS-232 data commands for SBI protocol

The RS232 can be set so a bidirectional connection can be established between the indicator and the host. To establish this connection set parameter P4 to 7, and configure setting P5 (baud) and P6 (parity) to host device. Commands can then be sent from the host to the indicator using the following commands (ensure the letters entered are in CAPS) (<CR> - Enter)

Command	Action	Response
W<CR>	Takes a reading Over capacity - Under capacity - Zero point error - Reading (kg or lb)	<LF>^^^^^^^u1u2<CR><LF>H1H2H3<CR><ETX> <LF>_____u1u2<CR><LF>H1H2H3<CR><ETX> <LF>-----u1u2<CR><LF>H1H2H3<CR><ETX> <LF><p>w1w2w3w4w5w6<dp>w7u1u2<CR><LF>H1H2H3<CR><ETX>
S<CR>	Prints Status Bytes	<LF>H1H2H3<CR><ETX>
Z<CR>	Zeros the scale	<LF>H1H2H3<CR><ETX>
T<CR>	Sets up a tare	<LF>H1H2H3<CR><ETX>
U<CR>	Changes the units	<LF>u1u2<CR><LF>H1H2H3<CR><ETX>
L<CR>	Activates the hold function	<LF>H1H2H3<CR><ETX>
X<CR>	Switches off the scale	Indicator switches off.
?	Unrecognised command	<LF>?<CR><ETX>

Key Symbols

<LF> Line feed

<CR> Carriage Return

<ETX> End of text character

<SP> Space

H1H2H3 3 status bytes

<p> Polarity character including minus sign for negative weigh and a space character for positive.

W1-W7 Weight data

<dp> Decimal point

U1U2: Unit measure, kg, lb or oz

Output Status Bit Meaning:

Bit	Byte 1	Byte 2	Byte 3
0	0=Stable	0=Not Under Capacity	00=Not defined
	1=Unstable	1=Under Capacity	01=Normal working mode
1	0=Not at zero point	0=Not over capacity	10=Hold working mode
	1=At zero point	1=Over capacity	11=Not defined
2	Always 0	Always 0	0=Gross Weight 1=Net Weight
3	0=eprom OK 1=eprom error	Always 0	Always 0
4	Always 1	Always 1	Always 1
5	Always 1	Always 1	Always 1
6	Always 0	Always 1	Always 0
7	Parity	Parity	Parity

Other RS-232 Output Strings

P4-1 = Output Displayed data @ print key :

Format:

<LF>< reading, minus, decimal point, weight unit><CR><EXT>

Example:

xxxxx0.18lb

P4-2 = Output Gross, Tare, Net @ print key

Format:

<LF><Gross: reading, minus, decimal point, unit><CR><EXT>

<LF> <Tare: reading, decimal point, unit><CR><EXT>

<LF> <Net: reading, minus, decimal point, unit><CR><EXT>

Example:

Gross:xxxxx0.18lb

Tare:xxxxxx0.18lb

Net:xxxxxxx0.18lb

RS232 serial interface wiring

DE-9 Female Scale			DE-9 Male Host		
Pin	Name	Direction	Pin	Name	Direction
2.	TXD	Out	2.	RXD	In
3.	RXD	In	3.	TXD	Out
5.	SG	-	5.	Ground	-

Pins 1, 4, 6, 7, 8, 9 not used

Scale calibration

Calibration Configuration Settings –

The scale is configured from the factory to match the specified settings for each unit, as defined by the product specifications and sales brochure. Modification of the setting can be accomplished by altering user configuration settings P7-P10. **Caution:** Calibration and/or configuration of calibration settings of your scale should be accomplished by a trained service technician using certified weights to ensure proper operation and accuracy. Calibration is not covered under warranty.

Setup Controls



Moves flashing digit



Change flashed digits

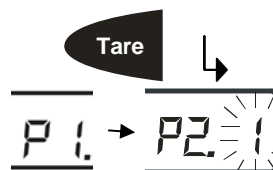

Saves data and move down to next Parameter setting



Exits setup mode

Config Menu	Avail. Settings	Default	Definition	Detailed Setting
P7	00-31	See table 2A	Displayed Resolution	(00) = 500 (08) = 2400 (15) = 7000 (01) = 600 (09) = 2500 (16) = 7500 (02) = 750 (10) = 3000 (17) = 8000 (03) = 800 (11) = 3500 (18) = 10,000 (04) = 1000 (12) = 4000 (19) = 12,000 (05) = 1200 (13) = 5000 (20) = 15,000 (06) = 1500 (14) = 6000 (21-31) = N/A (07) = 2000
P8	0,1,2	See table 2a	Division Increment	0 = 1 ; 1 = 2 ; 2 = 5
P9	0-5	See table 2a	Decimal Position	0 = 123456 ; 1 = 12345.6 ; 2 = 1234.56 ; 3 = 123.456 ; 4 = 12.3456 ; 5 = 1.23456
P10	0, 1	See table 2a	Calibration weight	0 = KG ; 1 = LB

Factory Calibration Settings shown in bold

Primary Capacity	Displayed Resolution	Units Selectable Capacity	P7	P8	P9	P10
150 lb x 0.02 lb	7500	75 kg x 0.01kg	16	1	2	1
150 x 0.05 lb	3000		10	2	2	1
150 x 0.1 lb	1500		06	0	1	1
300 lb x 0.05 lb	6000	150 kg x 0.02kg	14	2	2	1
300 x 0.1 lb	3000		10	0	1	1
300 x 0.2 lb	1500		06	1	1	1
600 lb x 0.1 lb	6000	300 kg x 0.05kg	14	0	1	1
600 x 0.2 lb	3000		10	1	1	1
600 x 0.5 lb	1200		05	2	1	1
75 kg x 0.01 kg	7500	150lb x 0.02lb	16	0	2	0
75 x 0.05 kg	1500		06	2	2	0
75 x 0.1 kg	750		02	0	1	0
150 kg x 0.02kg	7500	300lb x 0.05lb	16	1	2	0
150 x 0.05 kg	3000		10	2	2	0
150 x 0.1 kg	1500		06	0	1	0
300 kg x 0.05kg	6000	600lb x 0.1lb	14	2	2	0
300 x 0.1 kg	3000		10	0	1	0
300 kg x 0.2 kg	1500		06	1	1	0

Table 2a

You may choose to configure your scale for a higher resolution. The factory does not recommend increasing the resolution above 7,500 divisions for a stable weight reading. Certain environments may cause the scale to be unstable at factory settings, reduce the # of division settings to increase your stability.

Calibration Menu

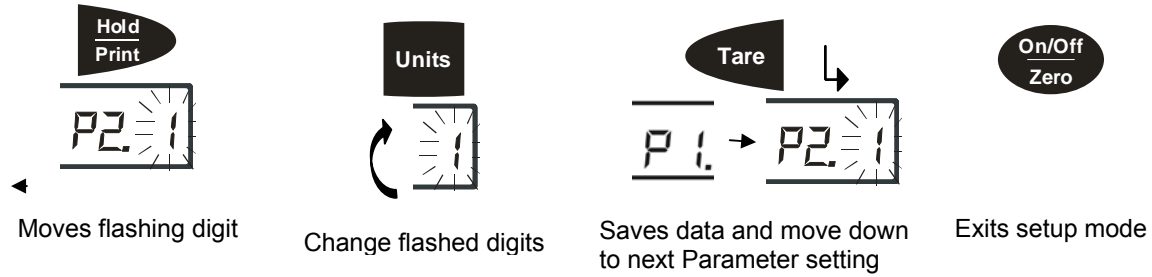

Calibration can be done with 25% to 100% of requested load and can be calibrated with 1 or 2 calibration points

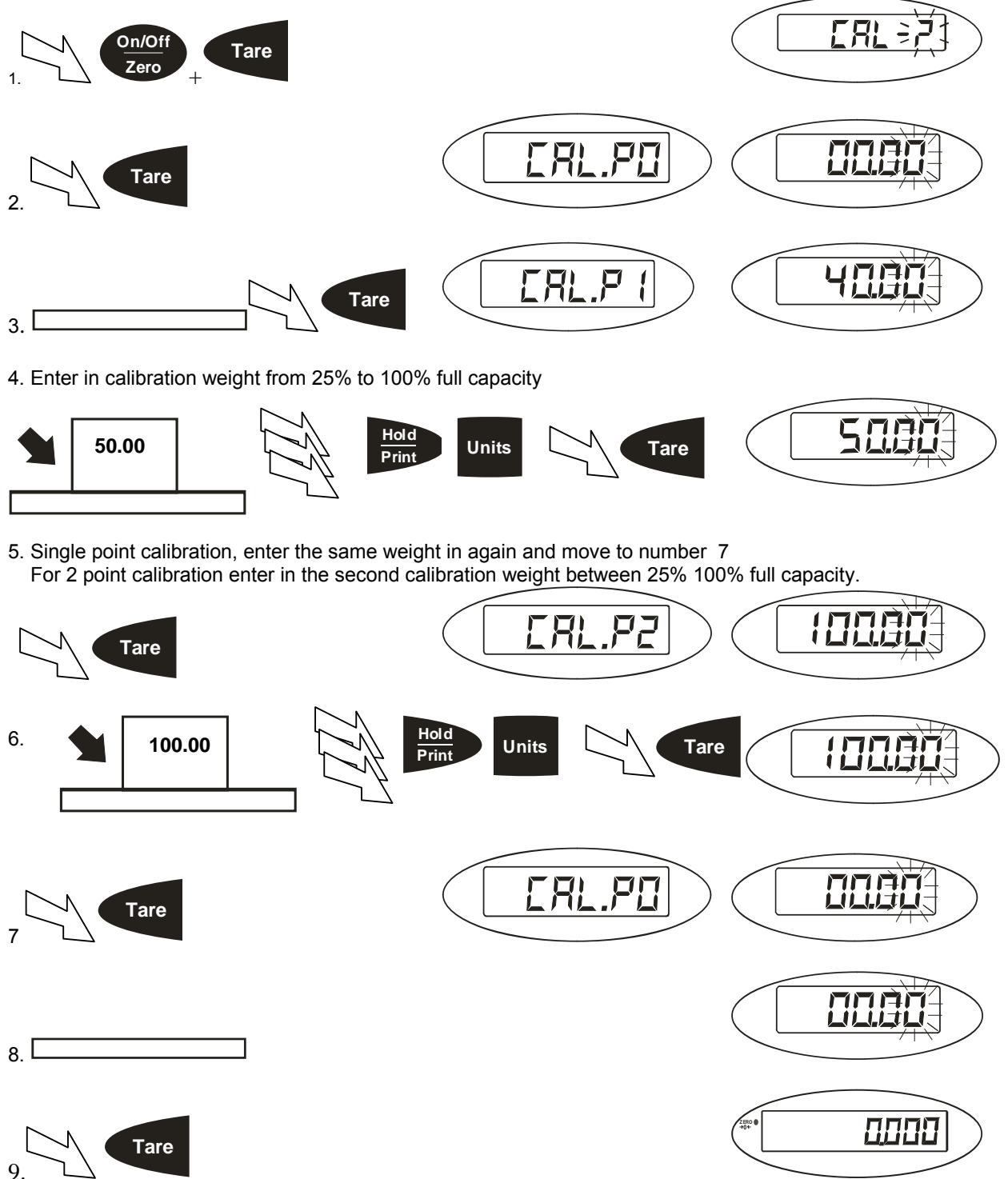

Service Configuration Settings

The scale is configured from the factory to match the specified settings for each unit, as defined by the product specifications and sales brochure. Modification of the setting can be accomplished by altering user configuration settings P11-P19. **Caution:** Configuration of the settings of your scale should be accomplished by a trained service technician to ensure proper operation and accuracy. Configuration is not covered under warranty.

Setup Controls

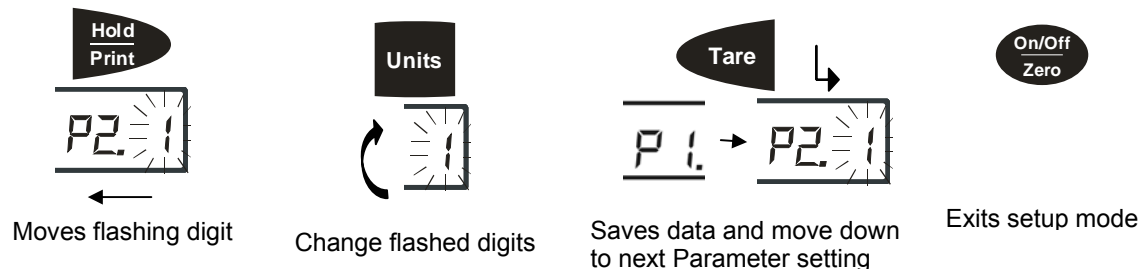

Config Menu	Avail. Settings	Default	Definition	Detailed Setting
P11	0,1,2	2	Units key configuration	0 = KG only ; 1 = LB only ; 2 = units key active KG and LB
P12	0-7	7	Power On zero range (full scale)	0 = +/- 1% ; 1 = +/- 2% ; 2 = +/- 5% ; 3 = +/- 10% ; 4 = +/- 20% ; 5 = +/- 50% ; 6 = +/- 100% ; 7 = no limitation
P13	00 - 15	3	Zero button range (Full scale)	(00) = +/- 1% (06) = +/- 20% (12) = + 5% (01) = +/- 2% (07) = +/-no limit (13) = + 10% (02) = +/- 3% (08) = + 1% (14) = + 20% (03) = +/- 4% (09) = + 2% (25) = + no limit (04) = +/- 5% (10) = + 3% (05) = +/- 10% (11) = + 4%
P14	0, 1, 2	0	Signal within power on zero point range	0 = current weight ; 1 = calibration zero ; 2 = power off zero point
P15	0, 1, 2	1	Signal not within power on zero point	0 = current weight ; 1 = calibration zero ; 2 = power off zero point ; 3 = continuously display "0-----"
P16	0-8	6	Zero tracking	0 = 0d AZT off ; 1 = +/- 0.25d, 2 = +/- 0.5d ; 3 = +/- 1d ; 4 = +/- 1.5d ; 5 = +/- 2d ; 6 = +/- 3d ; 7 = +/- 4d ; 8 = +/- 5d
P17	0-3	2	Data Filter	0 = very weak ; 1 = weak ; 2 = standard ; 3 = strong
P18	0 - 9	1	Weight stability	0 = +/- 0.5d ; 1 = +/- 1d ; 2 = +/- 1.5d ; 3 = +/- 2d ; 4 = +/- 3d ; 5 = +/- 4d ; 6 = +/- 5d ; 7 = +/- 6d ; 8 = +/- 7d ; 9 = +/- 8d
P19	0-9	1	Overload range Full scale	0 = 0% ; 1 = +9d ; 2 = 101% ; 3 = 102% ; 4 = 405% ; 5 = 110% ; 6 = 120% ; 7 = 150% ; 8 = 200% ; 9 = no limitation

Technical Specifications

Scale Indicator

Input signal range:	0mV ~ +30mV
Sensitivity:	>0.2uV/grad
Internal Resolution:	Approximately 520,000 counts
Display Resolution:	Can be selected between 500-100,000
System Linearity:	Within 0.01% of FS
Loadcell excitation Voltage:	+5 V _{DC} (MAX current: 85mA)

Loadcell

Sensitivity:	0.3mV/V --- 3mV/V (must be fit to >0.2uV/display grad.)
Input Resistor:	≥60 Ω
Output Resistor:	<10 KΩ

Temperature

Operation:	5°C - 35°C
Storage:	10°C - 70°C
Humidity:	≤95%RH (no condensation)

Power

Battery: 6V4AH lead acid battery, 30 hrs continuous use

When the voltage of battery is below 5.7V, the “Low Bat” annunciator will be lighted, plug in AC adapter to charge the battery. When “Lo.bAt” and actual weight is displayed alternately, this indicates the voltage of battery is below 5.5V and the scale will be turned off in two minutes automatically.

AC Adapter:
10.5-12V_{DC} 600mA, with central positive, 5.7 VDC -9 VDC



Error Messages

Error Message	Definition	Required Solution/Troubleshooting
0 ⁻⁻⁻⁻ :	Weight above range for calibrated zero point.	Remove load before zeroing Or Recalibrate the scale.
0 ₋₋₋₋ :	Weight below range for calibrated zero point.	Remove load before zeroing Or Recalibrate the scale.
----	Indicates an under range condition	Remove all loads and zero the scale.
----	Capacity exceeded	Remove the load and try again. If the load is great than 6 kg a scale with a larger capacity is required.
CAL-Er:	Calibration error	Restart calibration
Lo.bAt:	Low Battery	Recharge the battery. Upon initial use, it is recommended to charge battery for 8 hours prior to use.
EEP.E0	EEPROM can't be accessed	Replace S100 Indicator
EEP.E1	Configuration settings have changed and not been stored	Calibrate the scale to store settings
EEP.E2	P7-P9 settings exceed scale's normal range	Reconfigure P7-P9 setting

Declarations of Compliance

United States

This equipment has been tested and found to comply with the limits for a class A digital device, pursuant to Part 15 of the FCC Rules. These limits are designed to provide reasonable protection against harmful interference when the equipment is operated in a commercial environment. This equipment generates, uses, and can radiate radio frequency energy and, if not installed and used in accordance with the instruction manual, may cause harmful interference to radio communications. Operation of this equipment in a residential area is likely to cause harmful interference in which case the user will be required to correct the interference at his own expense.

Canada

This digital apparatus does not exceed the Class A limits for the radio noise emissions from digital apparatus set out in the Radio Interference Regulations of the Canadian Department of Communications.

Le présent appareil numérique n'émet pas de bruits radioélectriques dépassant les limites applicables aux appareils numériques de la Classe A prescrites dans le Règlement sur le brouillage radioélectrique édicté par le ministère des Communications du Canada.

		Declaration of Conformity	
Manufacturer		Salter Brecknell	
Type		S100	
Corresponds to the requirements of the following EC directives:-			
Electro Magnetic Compatibility Directive: Low Voltage Directive:		EMC 89/336/EEC LVD 73/23/EEC	
The application harmonised standards are:		EN60950 EN50081-1 EN50082-1	

A copy of the original signed declaration for this instrument is available from the UK address below.



USA
Salter Brecknell Weighing Products USA
1000 Armstrong Drive
Fairmont
MN 56031
Toll Free: 800-637-0529
Phone: 507-238-8702
Fax: 507-238-8271
email:sales@salterbrecknell.com
www.salterbrecknell.com

UK and Europe
Salter Brecknell Weighing
P.O. Box 9533, Smethwick,
West Midlands, B66 2TE.
United Kingdom.
Tel: +44 (0) 870 444 6132
Fax: +44 (0) 870 010 2241
email:sales@salterbrecknell.co.uk
www.salterbrecknell.co.uk