



# MODEL SB1227 10" 4-JAW INDEPENDENT CHUCK



## Instruction Sheet

PHONE: (360) 734-1540 • www.southbendlathe.com

### **⚠️ WARNING**

Chucks are heavy! Get assistance when installing or removing the chuck from the lathe. Wear heavy duty leather boots for foot and toe protection, and keep hands and fingers away from all pinch points. Ignoring this warning can lead to a severe crushing injury or finger amputation!



### Specifications

- OD Clamping..... 0.59"–8.46" (15–215mm)
- ID Clamping..... 2.95"–9.45" (75–240mm)
- Chuck Bore Diameter .....2.16" (55mm)
- Chuck Outer Diameter .....9.84" (250mm)
- Maximum Speed .....2750 RPM\*
- Mounting Type..... D1-5 Camlock
- Construction.....Fine-Grain Cast-Iron
- Chuck Weight..... 50 lbs
- Chuck Shipping Weight..... 51 lbs
- Country of Origin ..... Taiwan

\* The maximum speed listed above is ONLY possible with the chuck jaws and the workpiece in complete rotational symmetry. The workpiece weight must be within the limits of the lathe, and the workpiece mass must be of equal density throughout to prevent centrifugal imbalance or radial runout—even if a tailstock or other support is used for additional support.

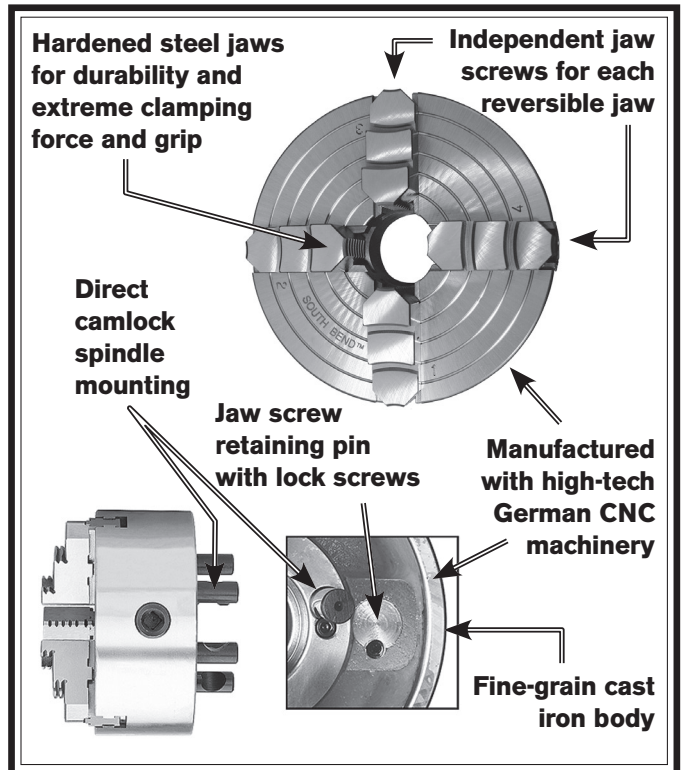

Figure 1. Features.

### Introduction

The Model SB1227 uses a direct mount D1-5 camlock system where the camlock studs are directly threaded into to the chuck body instead of being threaded into a backing plate that is bolted to the chuck. Without using a back plate to mount the chuck, the chuck jaws are positioned closer to the headstock which gives a longer distance between the jaws and the tailstock. Another benefit is that the distance between the jaws and the outboard spindle nose is reduced, so if a spider support is used on the outboard spindle, short gun barrels and other shorter workpieces can be held at both ends.

Copyright © October, 2010 by South Bend Lathe Co.

**WARNING:** No portion of this manual may be reproduced without written approval.

#CR13307 Printed in Taiwan

## Safety

- **Chuck Key Safety:** A chuck key left in the chuck can become a dangerous projectile when the spindle is started. Always remove the chuck key after using it. Develop a habit of not taking your hand off of a chuck key unless it is away from the machine.
- **Disconnect Power:** Disconnect the lathe from power before installing and removing the chuck or doing any maintenance or adjustments. Accidental lathe startup can cause severe injury or death.
- **Secure Clamping:** A thrown workpiece may cause severe injury or even death. When swapping the chuck jaw positions, keep in mind that maximum gripping force is attained at full jaw and jaw screw engagement. If only one is partially engaged, overall clamping force is reduced.
- **Speed Rates:** Operating the lathe where maximum chuck speed is exceeded, or at too high of a speed for an unbalanced workpiece, can cause the workpiece to be thrown from the chuck. Always use the appropriate feed and speed rates. A thrown workpiece may cause severe injury or even death.
- **Large Chucks:** Large chucks are very heavy and difficult to grasp, which can lead to crushed fingers or hands if mishandled. Get assistance when installing or removing large chucks to reduce this risk. Protect your hands and the precision ground ways by using a chuck cradle or piece of plywood over the ways of the lathe when servicing chucks.
- **Safe Clearances:** Often chuck jaws will protrude past the diameter of the chuck and can contact a coolant nozzle, tooling, tool post, or saddle. Before starting the spindle, make sure the workpiece and chuck jaws have adequate clearance by rotating then by hand through its entire range of motion by hand.
- **Stopping Lathe By Hand:** Stopping the spindle by putting your hand on the workpiece or chuck creates an extreme risk of entanglement, impact, crushing, friction, or cutting hazards. Never attempt to slow or stop the lathe chuck by using your hand. Allow the spindle to come to a stop on its own or use the brake (if equipped).
- **Long Stock Safety:** Long stock can whip violently if not properly supported, causing serious impact injury and damage to the lathe. Reduce this risk by supporting any stock that extends from the chuck/headstock more than three times its own diameter. Always turn long stock at slow speeds.

## Camlock Stud Installation

The camlock studs that are shipped with this chuck may be pre-installed from the factory. If so skip this section and complete **Chuck Installation and Removal on Page 4**; otherwise, install the camlock studs as outlined below:

1. Oil and thread each cam stud into the chuck until the alignment groove is flush with the chuck surface, as shown in **Figure 2**.
2. Install and tighten the locking cap screw for each stud, making sure that the camlock studs can slightly rotate back and forth.

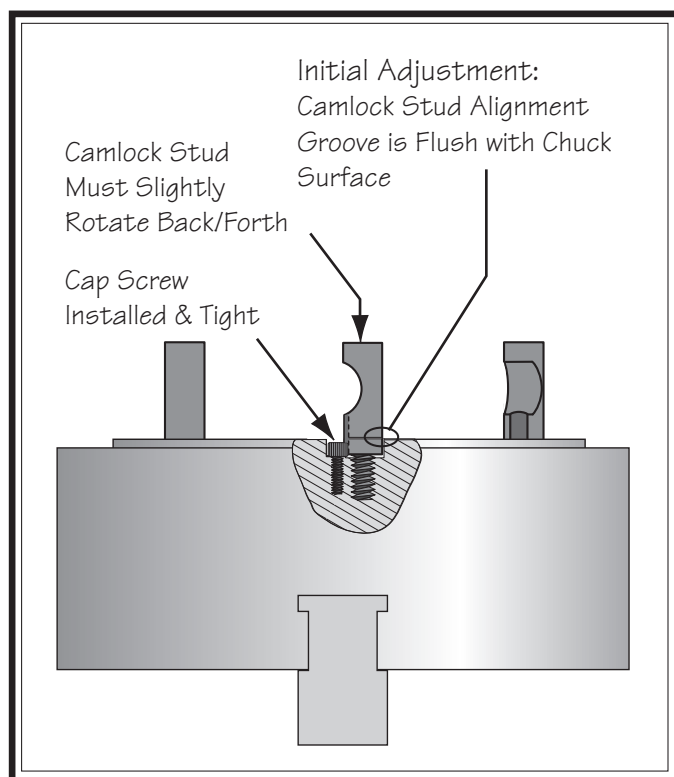
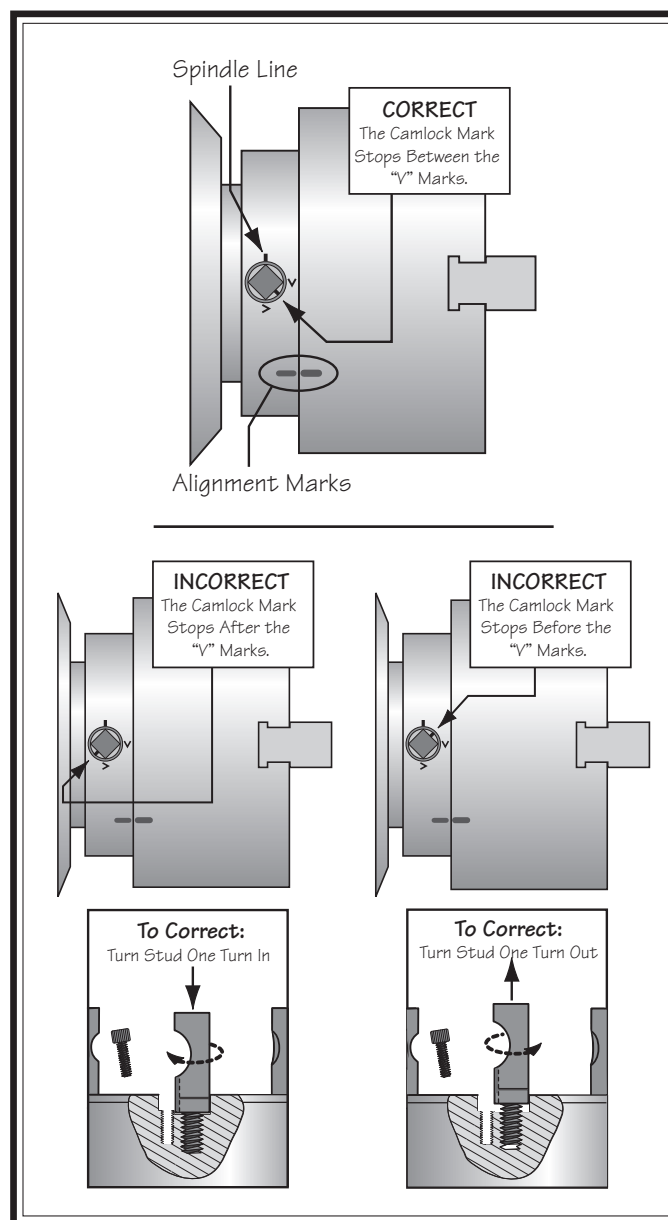

**Figure 2. Camlock stud installation.**

## Camlock Stud Adjustment

If the camlock studs have been pre-installed at the factory, or if you are installing them for the first time, slight machining differences between the lathe spindle and chuck can cause one or more camlocks to lock at the incorrect location.

If any cam line stops outside of a “V” mark when all of the camlocks have been tightened, remove the chuck and adjust the height of the offending stud one full turn up or down as illustrated below. After all camlocks operate correctly, stamp alignment marks in the chuck and spindle to ensure that the chuck can be re-installed in the same position after being removed.



**Figure 3. Camlock stud adjustment.**

## Chuck Installation and Removal

1. DISCONNECT LATHE FROM POWER!
2. Lay a chuck cradle (see **Figure 4**) or plywood under the chuck and over the bedway to protect the precision ground surfaces from damage and reduce the risk of fingers getting pinched.

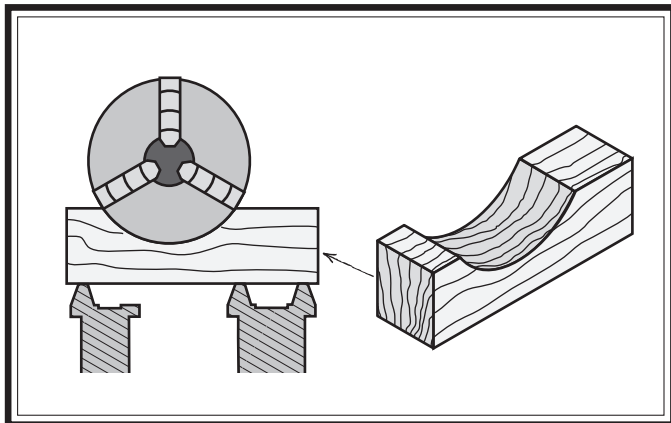

**Figure 4. Wooden chuck support cradle.**

3. Clean away debris and oily substances from the mating surfaces of the spindle and the chuck to ensure the best fit possible.
4. Inspect and make sure that all camlock studs are undamaged, clean, and lightly oiled.
5. Make sure that the camlock stud retaining cap screws are snug, but still allow the studs to be rotated back and forth slightly by hand. This free-play is critical to ensure that the camlocks tighten and lock with the studs completely, and will release without binding.
  - If a problem is found with the camlock locking or release, remove the offending stud and clean it with mineral spirits. Compare it with a good stud for any inconsistencies, and replace it if a problem is found. Inspect the bore, cap screw, seat depth, and threads with others that are known to be correct. Chase all threads, and remove any burrs or dings in the seat. Dry out the bore with compressed air and lightly re-lubricate with a drop or two of machine oil or way oil.

## NOTICE

Do not install the chuck without having the camlock cap screws in place or fully tightened. Otherwise, the camlock studs may turn with the camlocks on release, resulting in the chuck being permanently locked onto the spindle.

6. With the help of another person, or with the help of a chuck cradle, align the chuck with the spindle so the studs and camlock bores are aligned correctly, and carefully slide the chuck onto the lathe spindle. Never rest the chuck on its lower studs, as shown in **Figure 5**, and roll or push the top of the chuck into place on the spindle. This is a bad practice that may damage the studs and camlock bores.

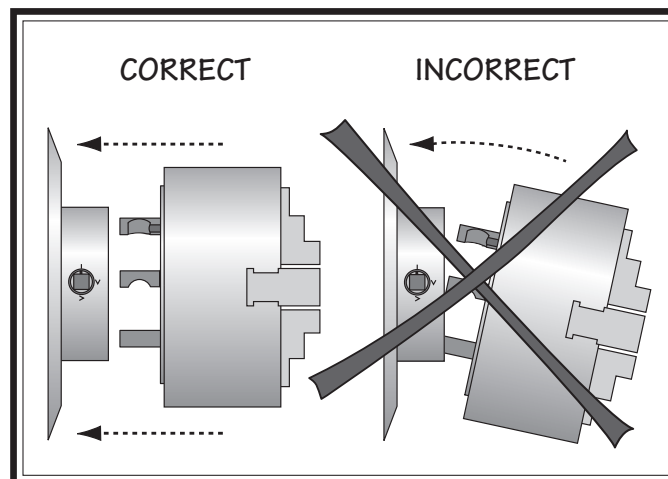

**Figure 5. Typical alignment of studs and camlock bores.**

## WARNING

Before turning the lathe ON, make sure the chuck key is removed! A thrown chuck key can cause serious injury or death to the operator or bystanders.

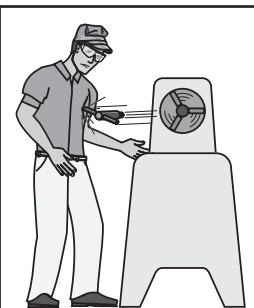

7. Tighten camlocks in a star pattern to draw the chuck in evenly and reduce the chance of misalignment. Make sure to tighten camlocks in an incremental manner to ensure that one camlock does not get fully tightened before the others (i.e., snug the camlocks on the first pass, then moderately tighten on the next pass, then fully tighten on the third pass).

As you tighten the camlocks, the chuck will seat with the spindle nose. When fully tightened, the cam line will fall between the two "V" marks on the spindle nose, as shown in **Figure 6**.

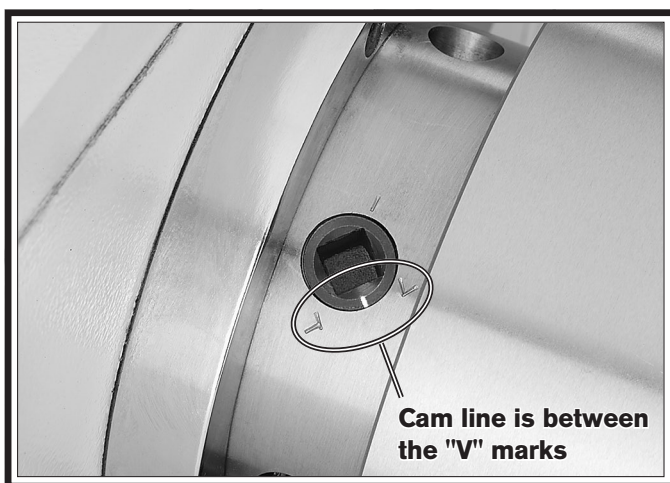

**Figure 6. Camlock is fully tightened with the camlock line positioned between the "V" marks.**

— If the cam is fully tightened, but the cam line is positioned outside of the "V" marks, remove the chuck and adjust the height of the offending camlock stud, as outlined in **Camlock Stud Adjustment** on **Page 3**.

8. When installation is complete and you are satisfied with the results, lightly stamp a set of alignment marks on the chuck and spindle.

**Note:** Alignment marks ensure that the chuck can be re-installed in the correct position every time for consistent chuck and spindle alignment. It also allows for the same camlocks and studs to operate together for consistent locking and unlocking.

### To remove the chuck:

1. DISCONNECT LATHE FROM POWER!
2. Lay a chuck cradle or plywood under the chuck and over the bedway to protect the precision ground surfaces from damage and reduce the risk of fingers getting pinched.

## ! WARNING

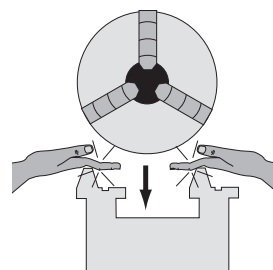

**PINCH HAZARD! Protect your hands and the precision ground bedways with plywood or a chuck cradle when removing the lathe chuck! The heavy weight of a falling chuck can cause serious injury.**

3. Loosen the camlocks by turning the key counterclockwise approximately one-third of a turn until the mark on the camlock aligns with the spindle mark on the spindle nose (see **Figure 7**). If the stud does not freely release from the camlock, wiggle the camlock until it stud releases.

**Note:** Camlocks can become very tight. A cheater pipe may be used to add leverage when loosening.

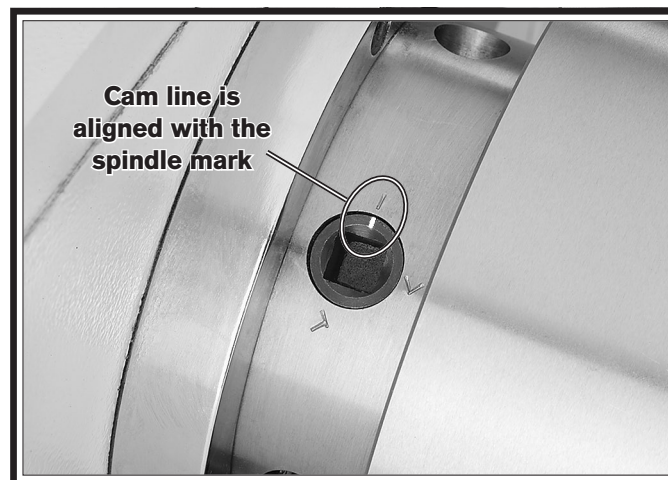

**Figure 7. Camlock is fully loosened when the camlock line is aligned with the spindle mark.**

**CAUTION: During the next step, the chuck may come off suddenly, so it is important that you are ready to support its weight with a chuck cradle to prevent crushing your fingers or dropping the chuck.**

4. Using a dead blow hammer or other soft mallet, lightly tap around the outer circumference of the chuck body to break the chuck free from the camlocks and the spindle nose taper.
5. Use a rocking motion to carefully remove the chuck from the spindle.

— If the chuck does not immediately come off, rotate the chuck approximately 60° and tap again. Make sure all the marks on the cams and spindle are in proper alignment for removal.

## Operation

Non-cylindrical parts can be held and brought into the spindle centerline for facing or boring. The other benefit is that the majority of workpieces can be positioned out of the spindle rotation axis if a bore (see **Figure 9**) or a step needs to be cut into a workpiece on an outlying edge. For the best grip possible on odd-shaped workpieces, one or more jaws can also be rotated 180° to grab more surface area for clamping. If all four jaws cannot be used to hold the workpiece, you must use faceplate to reduce the risk of a workpiece being thrown.

### To clamp a workpiece in the chuck:

1. DISCONNECT LATHE FROM POWER!
2. Install a center in the tailstock.
3. Retract each jaw and place the workpiece flat against the chuck face.
4. Slide the tailstock forward, so the tip of the dead center applies enough pressure against the workpiece to hold it in place, and then lock the tailstock in position.
5. Move each jaw until it makes light contact with the workpiece.

6. Following the sequence shown in **Figure 8**, tighten each jaw in small increments to move the workpiece into the required position. Check frequently to make sure the intended center point of the workpiece has not wandered away from the spindle centerline while the jaws are being tightened.

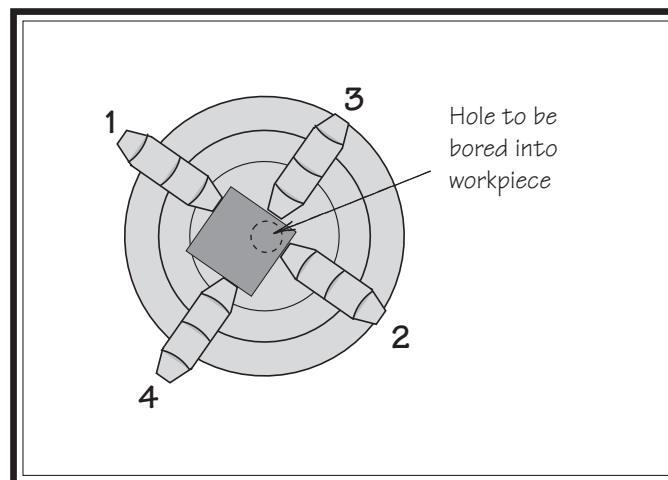

**Figure 8. Tightening sequence.**

7. After the workpiece is held in place by the jaws, turn the chuck by hand and pay attention to the workpiece alignment.

— If the workpiece is not correctly aligned for your operation, turn the chuck and make fine adjustments by slightly loosening one jaw and tightening the opposing jaw until the workpiece is correctly aligned (see **Figure 9** for an example).

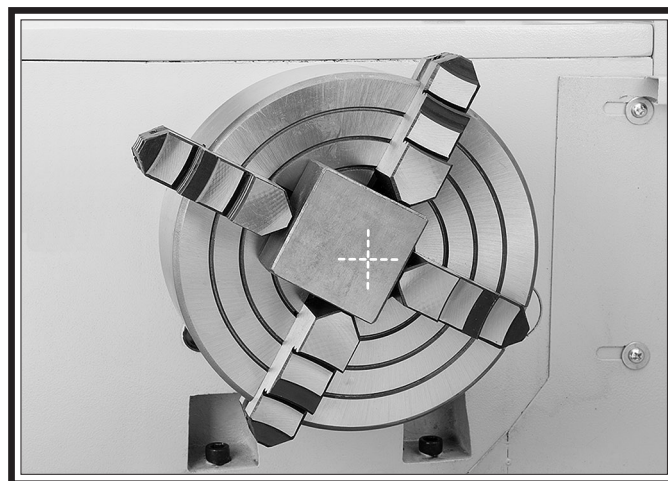

**Figure 9. Non-concentric workpiece correctly clamped in the 4-jaw chuck.**

## Care & Maintenance

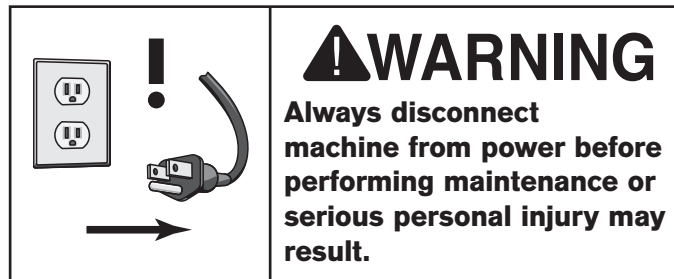

For optimum performance from your chuck, follow the maintenance schedule below. Never hammer on the chuck, jaws, or a workpiece that is clamped in the chuck; and never subject the chuck to abrasives, flame, or water.

### Daily:

- Check/correct loose mounting bolts.
- Keep the chuck clean and oiled.
- Use a vacuum, rag, or brush to clean the chuck after use. Never use air pressure to clean chips away from a chuck.
- Avoid leaving the chuck clamped on a workpiece, unload the chuck jaws daily.
- Make sure the chuck key is removed from the chuck when not in use.

If the chuck ever becomes stiff to operate, it may have been contaminated with metal chips or abrasives from incorrect or infrequent maintenance intervals. If this is the case, the chuck must be disassembled, cleaned, and re-lubricated.

### To disassemble the chuck for a full cleaning and lubrication service:

1. DISCONNECT LATHE FROM POWER!
2. Verify that chuck alignment marks are present so the chuck can be re-installed in the same position, and remove the chuck. Stamp the marks if they do not exist.
3. Leaving the camlock studs in place, disassemble the chuck in the sequence listed below and shown in **Figure 10**.
  - a. Place a set of wooden blocks under the chuck so the camlock studs do not rest on the table, and clamp the chuck to the table as shown in **Figure 10**.

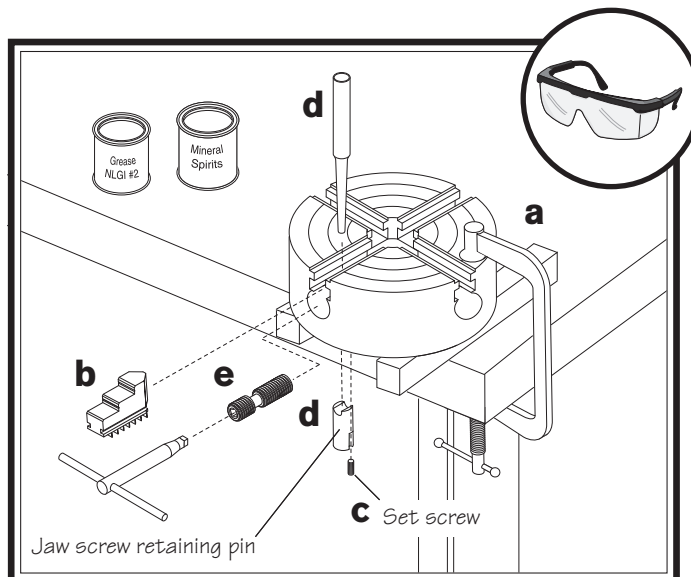

**Figure 10. Chuck sequence of disassembly.**

- b. Back the jaws out of the chuck
  - c. Remove the four set screws.
  - d. Put on safety glasses, and use a hammer and drift punch to tap out each jaw screw retaining pin.
  - e. Slide the jaw screws out of their bores.
4. Using mineral spirits, clean and dry all parts. Inspect and fix all bores, teeth, pins, and mating surfaces for wear, burrs, galling, rust, or cracks.
  5. Without changing the dimension of any part, use a wire brush, emery cloth, or dressing stones to remove all rust, burrs, or any high spots caused by galling.
  6. Coat all parts with any automotive NLGI #2 grease, and carefully re-assemble the chuck in the reverse order shown in **Figure 10**.
  7. Rotate the chuck key clockwise until the lead thread of each jaw screw is seen just entering the jaw guide, then insert each numbered jaw into its numbered slot.
  8. One at a time, hold each jaw against its jaw screw, and rotate the chuck key clockwise to engage the jaw screw with the jaw, then fully thread the jaw into the chuck.
  9. Align and re-install the chuck.

## Troubleshooting

Symptom	Possible Cause	Possible Solution
The chuck has hard spots or binds completely.	<ol style="list-style-type: none"> <li>1. Jaw is in a poor position for clamping.</li> <li>2. Lack of lubrication, rust, burr, or metal shavings inside of chuck.</li> <li>3. Broken tooth on the jaw or the jaw screw.</li> </ol>	<ol style="list-style-type: none"> <li>1. Re-install jaws for maximum engagement with jaw slot and jaw screw.</li> <li>2. Disassemble, de-burr, clean, and lubricate chuck.</li> <li>3. Disassemble chuck and repair/replace broken part.</li> </ol>
The workpiece slips in the jaws.	<ol style="list-style-type: none"> <li>1. Incorrect jaw or workpiece clamping position.</li> <li>2. Chuck is binding before full clamping force is achieved, or a jaw or jaw screw is binding.</li> <li>3. Cutting overload.</li> </ol>	<ol style="list-style-type: none"> <li>1. Re-install jaws for maximum engagement with jaw slot and jaw screw.</li> <li>2. Chuck is loaded up with contaminants. Disassemble and service chuck. Loosen and retighten the chuck key several times to distribute lubricant.</li> <li>3. Reduce cutting depth or feed rate.</li> </ol>
Clamping accuracy is poor.	<ol style="list-style-type: none"> <li>1. Workpiece improperly clamped or workpiece is misaligned.</li> <li>2. Chuck loose; mounting is off-center, or is improperly seated.</li> </ol>	<ol style="list-style-type: none"> <li>1. Remove jaws, clean, de-burr, and re-install; verify accuracy and recalibrate test/dial indicator.</li> <li>2. Remove chuck, clean and de-burr mounting; adjust camlock studs, and re-install chuck.</li> </ol>

## Parts List

REF	PART #	DESCRIPTION
1	P5B1227001	REVERSIBLE CHUCK JAW
2	P5B1227002	CHUCK BODY
3	P5B1227003	JAW SCREW
4	P5B1227004	JAW SCREW PIN
5	P5S02	SET SCREW 5/16-18 X 3/8
6	P5B1227006	CHUCK KEY
7	P5B1227007	D1-5 CAMLOCK STUD
8	PCAP04	CAP SCREW 1/4-20 X 1/2

## Parts Diagram

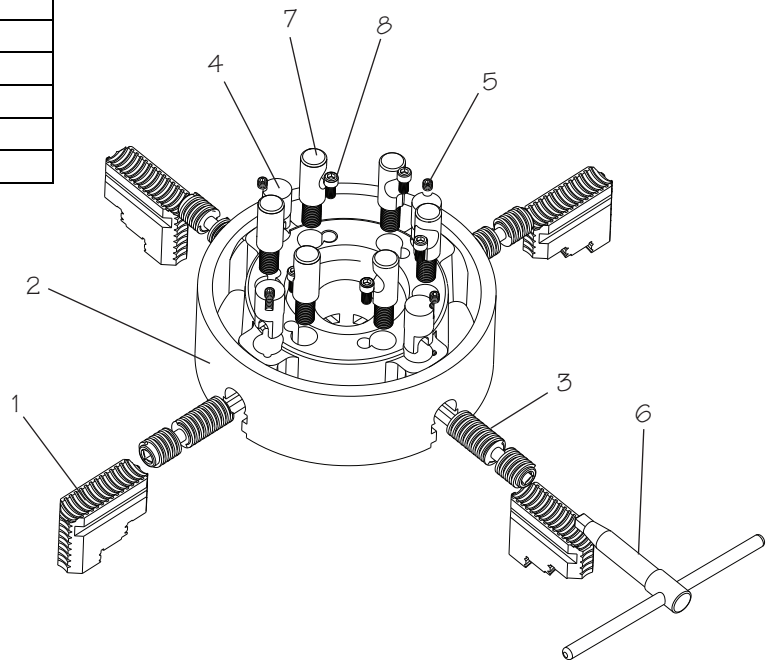

*If you need help with your new chuck, contact us at:*

**PHONE: (360) 734-1540**

**FAX: (360) 676-1075 (International)**

**FAX: (360) 734-1639 (USA Only)**

**EMAIL: sales@southbendlathe.com**

**Please Note:** We included this parts breakdown for service purposes only. Since many of the parts shown are machined to each individual chuck, they may not be available as replacement items.