



## Model SP4012

Equipped with a 35HP Briggs and Stratton Engine

Machine Serial # \_\_\_\_\_  
Engine Model & Spec # \_\_\_\_\_  
Engine Serial # \_\_\_\_\_  
Purchase Date \_\_\_\_\_  
Dealer \_\_\_\_\_

---

## Carlton

J.P. Carlton Company  
Div. D.A.F. Inc.  
121 John Dodd Road  
Spartanburg, SC 29303  
Ph. (864) 578-9335  
Fax (864) 578-0210  
[www.stumpcutters.com](http://www.stumpcutters.com)



**CALIFORNIA**

**Proposition 65 Warning**

**Diesel engine exhaust and some of its constituents are known to the State of California to cause cancer, birth defects, and other reproduction harm.**



**⚠ DANGER**

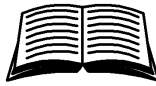

No inexperienced person may operate machine. Inexperience May cause injury.  
Read operation manual.

**⚠ WARNING**

IF THIS EQUIPMENT IS TURNED OVER, YOU WILL CAUSE ENGINE DAMAGE, HYDRAULIC DAMAGE, AND POSSIBLE PERSONAL INJURY.

**⚠ WARNING**



Loud noise. Flying debris.  
Hearing and eye protection must be worn while in operation.

**⚠ WARNING**



This machine may tip over sideways if operated on non level surface. Always use caution when operating on non-level surface.



**DAILY CHECKLIST:**

- ✦ Check engine oil. Check with engine sitting level. Add recommended oil (see engine owners manual) as required.
- ✦ Check air filters & precleaners. Inspect dry air cleaners. **DO NOT BLOW OUT OR TAP ON GROUND. REPLACE WITH MANUFACTURER RECOMMENDED AIR FILTER ONLY.**
- ✦ Check fuel filter for debris or water.
- ✦ Replenish fuel tank with fresh fuel.
- ✦ Check condition and tightness of belts.
- ✦ Check for any loose, broken or missing cutter teeth and pockets.
- ✦ Inspect bolts, hydraulic fittings, wiring harnesses, hoses, and equipment for tightness, wear, or leakage. Replace if necessary.
- ✦ Check hydraulic oil level. A sight gauge is located on the tank. Add oil if required.
- ✦ Check condition of tires. Inflate to proper pressure.
- ✦ Grease cutter wheel and jack shaft bearings before and after operation to keep dirt and moisture out. Purge until clean grease is seen.

↑ RIGHT	↑ FWD	↑ DOWN	↑ OUT	↑ LEFT
STEERING TRAVEL	UNIT TRAVEL	CUTTER WHEEL	TONGUE	HOOK TRAVEL
↓ LEFT	↓ REV	↓ UP	↓ IN	↓ RIGHT

**⚠ DANGER**

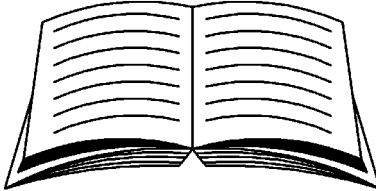

No inexperienced person may operate machine. Inexperience May cause injury.  
Read operation manual.

**⚠ WARNING**

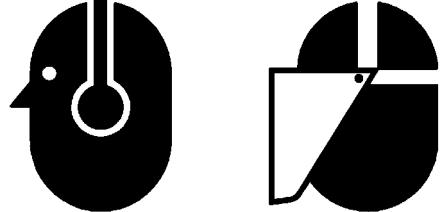

Loud noise. Flying debris.  
Hearing and eye protection must be worn while in operation.



 **WARNING**

IF THIS EQUIPMENT IS TURNED OVER, YOU WILL CAUSE ENGINE DAMAGE, HYDRAULIC DAMAGE, AND POSSIBLE PERSONAL INJURY.

 **WARNING**

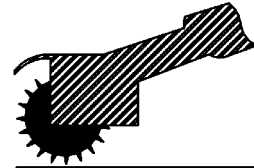

This machine may tip over sideways if operated on non level surface.  
Always use caution when operating on non-level surface.

 **DANGER**



**Stay clear while machine is in operation.**

**Cutter wheel will cause severe injury or death.**

JPC27

 **DANGER**

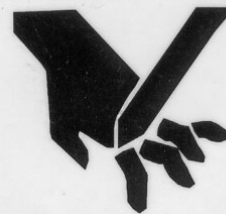

**Pinch Points**

**Keep body parts away while in operation.**

JPC09









DANGER

DO NOT MOVE,  
 POSITION, OR  
 TRANSPORT THIS  
 MACHINE WHILE  
 THE CUTTERWHEEL  
 IS ENGAGED.

JPC80

	<p style="text-align: center;"><b>WARNING (AVISO)</b> <b>(AVERTISSEMENT)</b></p> <p style="font-size: 0.8em;">TO PREVENT SERIOUS INJURY OR DEATH FROM MOVING PARTS:                  * KEEP HANDS, FEET, AND CLOTHING AWAY FROM MOVING PARTS.                  * CLOSE ALL GUARDS AND SHIELDS BEFORE OPERATING MACHINERY.</p>
	<p style="font-size: 0.8em;">PARA EVITAR LA LESION O LA MUERTE:                  * MANTENGANSE A DISTANCIA LAS MANOS, LOS                  PIES Y LA ROPA DE LAS PARTES MOVIMIENTOS DE LA MAQUINA.                  * CIERRAN TODAS LAS PROTECTORAS QUE HAY                  ANTES QUE HAGAN FUNCIONAR.</p> <p style="font-size: 0.8em;">AFIN D'ÉVITER TOUTE BLESSURE GRAVE OU LA MORT:                  * NE PAS RAPPROCHER LES MAINS, LES PIEDS                  OU LES VÊTEMENTS DES PIÈCES MOBILES.                  * S'ASSURER QUE TOUTES LES PIÈCES DE PROTECTION SONT EN                  PLACE AVANT DE METTRE EN MARCHÉ LA MACHINERIE.</p>

**WARNING (AVERTISSEMENT)**  
**(AVISO)**

	<ul style="list-style-type: none"> <li>• THREAD FULLY</li> <li>• TIGHTEN NUT</li> </ul>
<ul style="list-style-type: none"> <li>• ENROSCAR COMPLETAMENTE</li> <li>• APRETAR TUERCA</li> </ul>	<ul style="list-style-type: none"> <li>• VISSER À FOND</li> <li>• SERRER L'ÉCROU</li> </ul>

**WARNING**



KEEP AWAY FROM PRESSURIZED LEAKS

Pressurized leaks are not always visible. Check for pressurized leaks using cardboard or wood. Never use a finger, hand or other body part to check for leaks.

Injuries from pressurized leaks penetrating the skin will lead to serious health problems or death. CONSULT A PHYSICIAN IMMEDIATELY IF PENETRATION OCCURS, SURGICAL REMOVAL REQUIRED.

Release pressure from line before loosening, removing or replacing any hydraulic hoses or equipment.

0700317

**WARNING**



SEVERE ENGINE DAMAGE  
**WILL OCCUR IF THIS  
 ENGINE IS OPERATED AT  
 AN ANGLE GREATER  
 THAN 25°**

PROPER ENGINE OIL LEVEL  
 MUST BE MAINTAINED TO  
 ACHIEVE MAXIMUM ANGLE OF  
 OPERATION OF 25°  
 (SEE ENGINE OWNER'S MANUAL  
 FOR PROPER OIL LEVEL)

0700075A



## **⚠ WARNING**



### **FLAMMABLE FUEL**

THIS MACHINE USES DIESEL FUEL AND HYDRAULIC OIL.

NEVER FILL TANK WHILE ENGINE IS HOT, RUNNING, OR IN A CONFINED AREA. DANGER OF FIRE OR EXPLOSION EXIST.

LEAVE ROOM IN THE TANK FOR EXPANSION FROM HEAT - NEVER FILL TANK COMPLETELY FULL.

KEEP MACHINE AWAY FROM FIRE, SPARKS, AND OTHER SOURCES OF IGNITION DURING USE AND STORAGE.

NEVER PUT MACHINE IN STORAGE WITH FUEL IN THE TANK.

ALWAYS STORE FUEL IN APPROVED (RED) CONTAINERS AND AWAY FROM SOURCES OF IGNITION.

0700316

## **⚠ WARNING**

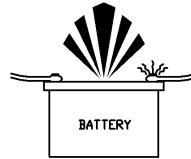

### **USE CAUTION IN EXTREME COLD! FROZEN BATTERY WILL EXPLODE!**

NEVER JUMP START A BATTERY IN FREEZING TEMPERATURES. INSPECT BATTERY FOR SIGNS OF FROST BEFORE STARTING IN EXTREME COLD. MOVE EQUIPMENT TO A HEATED, WELL VENTILATED AREA TO ALLOW BATTERY TO THAW BUT NOT NEAR FIRE, SPARKS, OR OTHER SOURCES OF IGNITION.

BATTERY FUMES ARE EXPLOSIVE. NEVER USE JUMPER CABLES OR RECHARGE BATTERY UNLESS IN AN OPEN OR WELL VENTILATED AREA AND AWAY FROM ALL SOURCES OF IGNITION.

BATTERY ACID CAN CAUSE SEVERE BURNS. KEEP AWAY FROM EYES, SKIN, AND CLOTHING.

ALWAYS REMOVE BATTERY BEFORE WELDING ON EQUIPMENT. FOLLOW PROCEDURES FOR WELDING AND GROUNDING BEFORE STARTING TO WELD ON THIS MACHINE OR EQUIPMENT DAMAGE AND POSSIBLY SEVERE PERSONAL INJURY WILL OCCUR.

0700314

## **NOTICE**

### **SERVICING BELTS AND BEARINGS**

ALWAYS TURN OFF ENGINE AND REMOVE KEY BEFORE SERVICING! ALLOW ALL PARTS TO COME TO A COMPLETE STOP AND COOL BEFORE TOUCHING!

- New belts stretch and get loose. After 2 hours of operation, check tension and tighten belts.
- Check tension and retighten every 4 hours of operation until tension stays consistent.
- See manual for instruction and proper tension.
- Thereafter, check belt tension every month until belts need replacing.

#### **AT LEAST ONCE A MONTH:**

- CHECK AND TIGHTEN BOLTS AND LOCK SETSCREWS ON ALL BEARINGS.
- CHECK AND TIGHTEN SCREWS ON ALL BELT PULLEY BUSHINGS.

**REFER TO MAINTENANCE SECTION**

0700311

## **NOTICE**

Premature engine failure could occur without proper maintenance of outboard bearing. See manual for further information.

JPC

**DIESEL MACHINES ONLY**

## **NOTICE**

DECALS SHOULD BE PROPERLY MAINTAINED AND REPLACED. IT IS THE DUTY OF THE OWNER OF THIS EQUIPMENT TO KEEP DECALS IN GOOD CONDITION.

REPLACEMENT DECALS MAY BE PURCHASED FROM  
J. P. CARLTON CO.

0700309





# STUMP GRINDER LIMITED WARRANTY

J.P. Carlton Co. Inc., hereafter referred to as the "Manufacturer", warrants each new Carlton Grinder to be free of defects in workmanship and material for a period of one year.

This warranty takes effect upon delivery to the original retail purchaser. The manufacturer, at its option, will replace or repair, at a point designated by the manufacturer, any parts which appear to have been defective in material or workmanship. The manufacturer is not responsible for consequential damages.

This warranty will not apply if the grinder is not operated in a manner recommended by the manufacturer. The following examples would void warranty:

1. The grinder has been abused.
2. The machine is involved in or damaged by an accident.
3. Repairs or attempted repairs were made without prior written authorization.
4. Including but not limited to repairs made due to normal wear.

The owner is responsible for all regular maintenance as explained in the operators' manual. Neglect in regular maintenance or failure to replace normal wear items such as teeth, pockets, lubrication oils, filters, belts, bearings, etc. may void warranty.

This warranty is expressly in lieu of any other warranties, expressed or implied, including any implied warranty or merchantability of fitness for a particular purpose and of any non-contractual liabilities including product liabilities based upon negligence or strict liability. J.P. Carlton Co. Inc. will not be liable for consequential damages resulting from breach of warranty.

IT IS NECESSARY TO RETURN THE WARRANTY VALIDATION FORM AND NOTIFY J.P. CARLTON CO. INC. IN WRITING WITHIN TEN (10) DAYS FROM DELIVERY DATE TO VALIDATE THIS WARRANTY.

NOTE: This warranty applies only to new and unused equipment or parts thereof manufactured by J.P. Carlton Co. Inc. ANY MACHINES USED FOR LEASE OR RENTAL - WARRANTY IS LIMITED TO 90 DAYS FROM FIRST DAY OF INITIAL SERVICE.

**NOTICE: All power units and associated components are NOT warranted by J.P. Carlton Co. Inc. or their dealers. It is the customers' responsibility to return machine to the local engine distributor.**

### INFORMATION PHONE NUMBERS TO FIND YOUR LOCAL ENGINE & PARTS SERVICE CENTERS:

- Honda ..... 1-770-497-6400 (GA-Eastern Time Zone)
- Kohler Engines..... 1-800-544-2444 (Toll Free)
- Briggs & Stratton Engines..... 1-800-233-3723 (Toll Free)
- Lombardini ..... 1-770-623-3554 (GA-Eastern Time Zone)
- Deutz Engines..... 1-800-241-9886 (Toll Free)
- John Deere Engines ..... 1-800-533-6446 (Toll Free)
- Caterpillar ..... 1-877-636-7658 (Toll Free)
- Kubota ..... 1-847-955-2500 (IL-Central Time Zone)
- Kawasaki Engines..... 1-616-949-6500 (MI-Eastern Time Zone)
- Wisconsin Engines ..... 1-800-932-2858 (Toll Free)
- Onan Engine ..... 1-800-888-6626 (Toll Free)

In order to process any warranty claims, it is the owners' responsibility to report claims promptly to us or our authorized dealer from whom the equipment was purchased. It is necessary to include the following information on any and all request for warranty:

- |                               |                                  |
|-------------------------------|----------------------------------|
| 1. Dealer from whom purchased | 5. Engine make and serial number |
| 2. Date of delivery           | 6. Length of time in use         |
| 3. Serial number of unit      | 7. Date of failure               |
| 4. Model number of unit       | 8. Nature of failure             |



## **EXPLANATION OF LIMITED WARRANTY**

The manufacturer will not reimburse the customer or dealer labor cost incurred for installing “bolt-on” or “slip-on” items, such as pumps and motors, bearings, belts, pulleys, etc. The manufacturer will provide replacement parts at no cost to the customer for defective parts during the warranty period. Defective parts must be returned to J.P. Carlton Company. It will be the customers’ responsibility to install the replacement parts unless arrangements are made with the selling dealer.

The manufacturer will not reimburse travel cost to servicing dealer. It is the customers’ responsibility to deliver machine to dealers facility, unless other arrangements have been agreed to between the selling dealer and the customer.

The manufacturer may elect, at its discretion, to reimburse reasonable labor cost to customer or dealer for major defect repairs. Prior approval must be obtained from J.P. Carlton Company Inc.

## **IMPORTANT NOTICE**

- 1. AIR FILTER MAINTENANCE IS CRITICAL ON STUMP GRINDING MACHINES. DIRT INGESTION WILL NOT BE WARRANTED BY THE ENGINE MANUFACTURER OR J.P. CARLTON COMPANY.**
- 2. OIL AND OIL FILTER MAINTENANCE AND STAYING WITHIN THE LIMITS OF THE ANGLE OF OPERATION IS ALSO CRITICAL ON STUMP GRINDING MACHINES. STARVING THE ENGINE FOR OIL WILL NOT BE WARRANTED BY THE ENGINE MANUFACTURER OR J.P. CARLTON COMPANY.**





# Warranty Validation Form

Congratulations on your purchase of a Carlton Stump Grinder. This product has been designed and manufactured to provide years of profitable service while minimizing maintenance and downtime. Please take the time now to complete this warranty validation form. This information is necessary for Carlton to instate your warranty.

Return Form To: J.P. Carlton Company, Div. D.A.F. Inc.  
121 John Dodd Road  
Spartanburg, SC 29303  
Phone: 1-864-578-9335

## Purchaser Information:

Company Name: \_\_\_\_\_ Street Address: \_\_\_\_\_  
City: \_\_\_\_\_ State: \_\_\_\_\_ Zip Code: \_\_\_\_\_  
Telephone: \_\_\_\_\_ Contact: \_\_\_\_\_

## Machine Information:

Model Number : \_\_\_\_\_ Engine Model : \_\_\_\_\_  
Serial Number : \_\_\_\_\_ Serial Number : \_\_\_\_\_

## Dealer Information:

Dealer Name: \_\_\_\_\_ Street Address: \_\_\_\_\_  
City: \_\_\_\_\_ State: \_\_\_\_\_ Zip Code: \_\_\_\_\_  
Contact Name: \_\_\_\_\_

1. \_\_\_\_\_ Customer has been instructed on operation and safety aspects of operating the equipment.
2. \_\_\_\_\_ Customer has been advised not to reach into cutter wheel area.
3. \_\_\_\_\_ Customer has been advised to stop machine and remove key before performing any type of maintenance.
4. \_\_\_\_\_ Customer has been warned not to operate the machine without the cutter wheel guard in place.
5. \_\_\_\_\_ Customer has been furnished with all parts and operators manuals.
6. \_\_\_\_\_ Customer has been instructed on equipment maintenance schedules and procedures.
7. \_\_\_\_\_ Customer has been advise that the engine or power unit that is used on this machine is warranted by the engine manufacturer and ***NOT J.P. Carlton Company***. All engine warranty issues should be addressed to the local engine dealer.
8. \_\_\_\_\_ Customer understands the importance of air and oil filter maintenance, and the importance of staying within the angle of operation of the engine. If either of these is not adhered to, the engine warranty is ***VOID***.
9. \_\_\_\_\_ Customer understands to keep locking collars tight and purge bearings with grease.
10. \_\_\_\_\_ All operation and warning decals are properly displayed on equipment.
11. \_\_\_\_\_ Customer understands it is his responsibility to train all operators on operator safety.

I have inspected this equipment and find it in good working condition. To the best of my knowledge, the customer and his personnel are aware of the above procedures.

Date: \_\_\_\_\_ Signed: \_\_\_\_\_  
Dealer Representative

The equipment has been thoroughly checked by the above named dealer representative, and I am satisfied with his instructions.

Date: \_\_\_\_\_ Signed: \_\_\_\_\_  
Purchaser



**INTRODUCTION**

FOREWORD	1
GENERAL INFORMATION	2
MACHINE FEATURES	3
MACHINE SPECIFICATIONS	4

**OPERATION**

SAFETY PRECAUTIONS	5
DAILY CHECKLIST	9
MACHINE CONTROLS	10
TRANSPORTING	20
MACHINE OPERATION	22

**MAINTENANCE**

MACHINE MAINTENANCE	25
LUBRICATION CHART	29
TROUBLESHOOTING GUIDE	30
SERVICING BELTS	32
SERVICING BEARINGS	41
SERVICING FRONT AXLE	49
SERVICING BOOM PIVOT	50
SERVICING CUTTER WHEEL	51
SERVICING HYDRAULICS	56
MACHINE WIRING	60

**PARTS**

HYDRAULIC ASSEMBLY	64
FRONT AXLE ASSEMBLY	77
REAR WHEEL ASSEMBLY	81
PIVOT ASSEMBLY	83
BOOM ASSEMBLY	86
CHIP GUARD ASSEMBLY	96
BACK	
RADIO CONTROL MANUAL	
ENGINE MANUAL	





Congratulations on your purchase of a new Carlton® Professional Stump Grinder! Carlton® Stump Grinders have a reputation for superior performance and reliability. A machine is not profitable if it's broken-down and we do our absolute *best* to help you avoid costly downtime. Each and every machine has been *over* designed and overbuilt to ensure years and years of trouble-free operation. In this, we take pride.

The Carlton® Model SP4012 is designed and intended for use in unique situations where size and maneuverability are foremost. As a result, the Model SP4012 has its own unique operational requirements.

Read this manual carefully and TAKE RESPONSIBILITY for thoroughly familiarizing yourself with the controls and the concepts behind the operation of this machine before attempting to operate it. Slowly experiment with the controls and gradually work yourself up to the full capabilities of this machine. The Carlton® Model SP4012 is a durable and profitable professional stump grinder. Read this manual, the engine manual and the safety and operational decals on the machine. Use proper safety precautions. Follow the instructions and use common sense and your "OX" will perform like its namesake. If getting more work done in a day, with less trouble, is your idea of good business, then you'll *love* your new Carlton® Stump Grinder.

We welcome your suggestions on how we might better build our machines. We solicit any and all questions concerning the safe operation or proper servicing of your new stump grinder.

Please feel free to write to us with any comments.  
We'll enjoy hearing from you!

The J. P. Carlton Company constantly strives to create the best professional tree equipment available in the industry. Therefore, the material in this manual is correct at the time of publication. Carlton® reserves the right to make improvements, modifications, and even discontinue features as we deem necessary to meet our goal. Carlton® also reserves the right to discontinue models without any prior notification or obligation.

Inspect your new Carlton Chipper as soon as you receive it. Any damages incurred during shipment are not warranted and, therefore, are not covered repairs. You should have the truck driver verify or acknowledge any damages caused during shipment. If not, contact the truck lines as soon as possible with your complaint.

Any reference made to the right, left, front, or rear in relationship to the chipper is illustrated in the following pictures. Please refer to these any time you call your dealer or J. P. Carlton for parts or assistance.

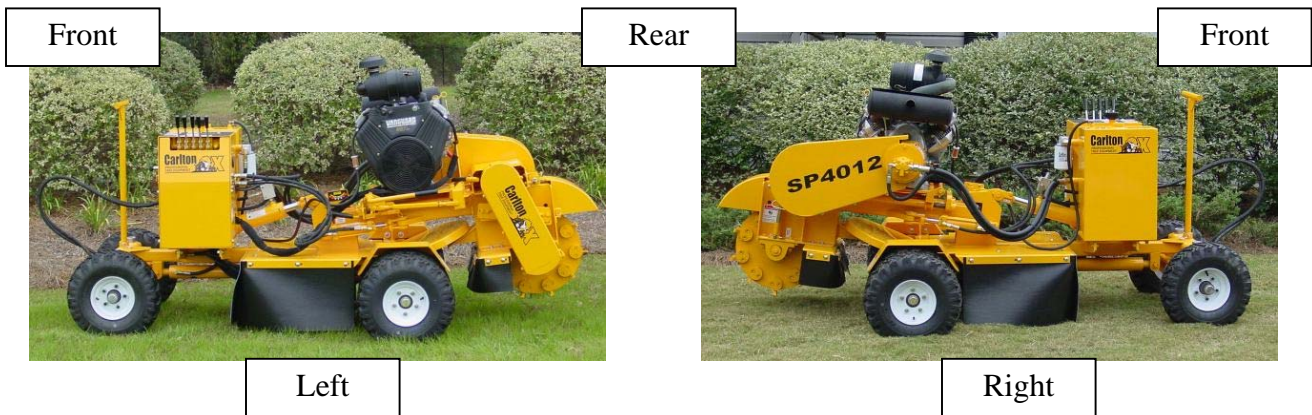



- Direct drive hydraulic pump
- Dual hydraulic motor propulsion
- Hydraulic controls
- Freewheeling capability
- Safety valves permit unaffected operation uphill, downhill or level
- Heavy construction
- 30" extension tongue
- Heavy duty tongue stake
- Counterbalancing valve
- Dual swing cylinders
- Hardened bushings in rotating cylinders
- Four wheel stance
- Hydraulic steering
- Adjustable Timken tapered roller bearings in the pivot head with hardened shafts
- Tapered roller bearings on cutter wheel & jackshaft
- 1" thick Blanchard ground cutter wheel
- 20 carbide tipped cutter teeth
- 35" width to clear narrow fence gates
- Double wire braid hose & hydraulic lines
- Safety tie down loops
- 1/4" plate fenders
- Epoxy primer
- DuPont Imron® protective finish
- Key start
- High capacity battery
- Premium tires
- Heavy duty rubber and metal chip guards
- Hour meter
- Large hydraulic tank
- Hydraulic and fuel filters
- Removable chip flap
- Poly Chain® Belt to cutter wheel
- Easy engine belt adjustment

**We Pride Ourselves  
in the strength and quality of each and every machine**

Engine.....	Briggs & Stratton 35HP Vanguard
Weight .....	1650 Lbs.
Length.....	8' 6"
Tongue Extension.....	30"
Height .....	46"
Width.....	35"
Cutting Depth Below Ground .....	13"
Cutting Height Above Ground .....	34"
Cutter Head Swing .....	40" Arc
Number of Teeth on Cutter Wheel .....	20
Cutter Wheel Diameter w/Teeth.....	21"
Cutter Wheel Thickness .....	1" Blanchard Ground
Jackshaft Bearings.....	1 11/16"
Cutter Wheel Bearings .....	1 11/16"
Tire size .....	8 ply 5.70-4
Fuel Tank Capacity .....	10.3 Gallons
Hydraulic Tank Capacity .....	3.6 Gallons



Before operating the stump cutter, read this manual, the engine manual, and all the safety decals on the machine. Know all parts of the machine and their functions, especially the shut down procedures in case of emergency. No inexperienced person may operate machine. Inexperience may cause injury.

**SAFETY FIRST ALWAYS!**

This is the **Safety-Alert Symbol**. This symbol is placed on the machine and in the manual to alert the operator to the potential for bodily injury or death. The operator should pay close attention to the instructions whenever they see this symbol.



The **Safety-Alert Symbol** will be accompanied by one of the following words:

**DANGER, WARNING, or CAUTION**

- A **DANGER** symbol means that if the instructions are not followed the possibility of serious personal injury or death is probable.
- A **WARNING** symbol means that if the instructions are not followed there is a possibility of serious personal injury or death.
- A **CAUTION** symbol means there is an unsafe condition or practice that may cause personal injury or property damage.

**PERSONAL PROTECTION:**

- ❖ Wear face shield and hearing protection
- ❖ Do not wear loose-fitting clothing
- ❖ Tie back long hair
- ❖ Do not wear jewelry
- ❖ Keep clear of cutter wheel
- ❖ Keep away from moving parts
- ❖ Only operate in a well ventilated area because of carbon monoxide

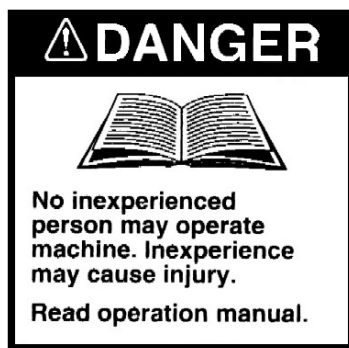
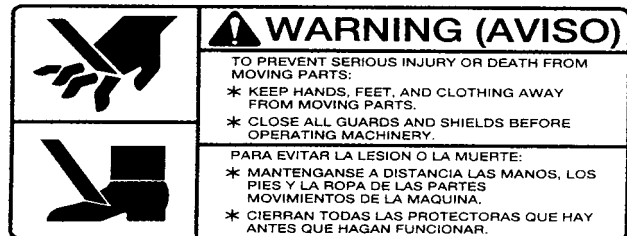

P/N 0700008



P/N 0700010



P/N 0700027

**Be Safe and Practice Safe Operation using the following guidelines.**



- Any individual operating this machine must first read and understand this manual, the engine manual, all component manuals, and all safety decals on machine.
- DO NOT permit children to operate machinery or to play near machinery during operation.
- Always wear face shield and hearing protection during operation. Loud noise and flying debris may cause severe injury.
- Keep hands, feet, legs, clothing, hair and all other body parts away from cutter wheel and other moving machine parts to eliminate the possibility of injury.
- Shut down machine completely and remove key before removing debris from work area (i.e. clearing rocks, wood chips, etc.).
- DO NOT modify or change any part without written approval from J. P. Carlton Company.
- Do not ride, sit, stand, lay or climb anywhere on this machine during operation, while running, or during transport.
- Do not move, position, or transport this machine while cutter wheel is engaged.
- DO NOT operate any machinery while under the influence of alcohol or drugs (prescription, over the counter, or otherwise).
- Do not refill fuel tank while engine is hot, running, or indoors. Danger of fire or explosion exists.
- Fuel and its vapors are highly flammable and explosive. **Handle with care.** Only use approved (red) fuel containers for storage.
- Do not store fuel containers near any open flames, sparks or other sources of ignition.
- Do not store equipment with fuel in the tank.
- Battery fumes are explosive. Recharge battery in an open area away from fire, sparks, or other sources of ignition.
- Battery acid can cause severe burns. Keep away from eyes, skin, and clothing.
- Always remove battery before welding on equipment.
- Never check for hydraulic leaks using hand or finger, use cardboard or wood. Keep away from pressurized leaks. Pressurized fluid can penetrate the skin and cause injury or even death. Seek immediate medical attention if penetration occurs. Always wear eye protection.



 **WARNING**

- **DO NOT OPERATE THE ENGINE AT AN ANGLE GREATER THAN 25° OR SEVERE ENGINE DAMAGE WILL OCCUR.** PROPER ENGINE OIL LEVEL MUST BE MAINTAINED TO ACHIEVE MAXIMUM ANGLE OF OPERATION OF 25°. (See Engine Owner's Manual for proper oil level.)
- Never allow spectators to stand and watch machine in operation without proper hearing and eye protection and standing at a safe distance. Loud noise and flying debris may cause severe injury.
- Do not operate around water, gas, power or phone lines. Check with property owner or call utilities if not sure.
- Avoid fences and clear away other objects (i.e. sticks, stones, metal, etc.).
- Be aware of the possibility of foreign objects imbedded in or buried around the stump. Do not cut crosswise of roots above ground to prevent roots being thrown.
- If unusual vibration occurs, stop engine immediately and correct problem before continuing operation.
- Keep all guards in place and properly secured during operation.
- Keep all safety devices working properly and all other machine parts in good working condition.
- Never leave the controls unattended while in operation. Be sure machine is not capable of operation when left unattended.

 **WARNING**



- Stop engine and remove key when repairing or adjusting machine or drive belts.
- Keep engine in good condition service as instructed in engine manual.
- Do not touch engine while running or hot (serious burns may result).
- Allow all machine parts to cool sufficiently before servicing or making adjustments. Hot machine parts can cause severe burns.

 **WARNING**

- Do not run the machine without a complete number of teeth in the cutter wheel tightened to the correct torque.
- Do not place machine in free wheel without first placing tongue stake in the ground.
- Park machine on level surfaces only. Lower cutter head to the ground and use wheel chocks to prevent unattended movement.

 **CAUTION**

- Do not operate stump cutter in dark, dim lit, or concealed areas.
- Keep machine clean and clear of debris to eliminate fire hazard. It is especially important to clean any oil or fuel spills to prevent the danger of fire.
- Keep cutter wheel skirt guards in good condition to help control chips during grinding.
- Keep safety and instructional decals clean and replace any that are damaged, difficult to read, or missing. Decals may be purchased from J. P. Carlton or an authorized dealer.

**ATTENTION:**

The Carlton® Model SP4012 Stump Grinder CAN be overturned on steep inclines. This can cause serious injury to operator and machine. **DO NOT OVERTURN!**



P/N 0700024

- Avoid steep side inclines when operating this machine! The narrow design width required in operating the model SP4012 in tight confines makes it susceptible to tipping over sideways. Overturning this machine can result in personal injury, property damage and/or seizing the engine.

**USE CAUTION.**

- Positioning the **cutter wheel uphill** and as close to the ground as possible while in transit will minimize the danger of tipping over and maximize the steadiness of the Model SP4012.
- When encountering a hill, the best approach is straight up or straight down. Avoid any side angles whenever possible.  
**NEVER ALLOW INEXPERIENCED PERSONS TO OPERATE THIS MACHINE.**

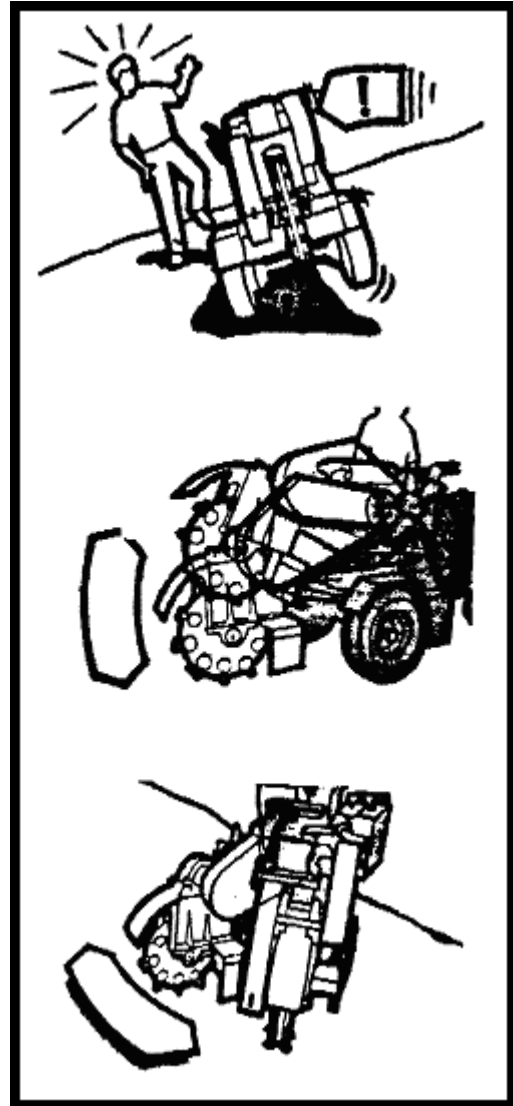

- Check engine oil at dipstick. Take reading with engine sitting level (see photos). Add recommended oil as required (see engine owners' Manual).
- Check fuel filter for debris or water.
- Replenish fuel tank with fresh fuel.
- Check condition and tightness of engine belts. (See Servicing Belts section) New belts will stretch and become loose as machine runs. Check belt tension often when belts are new.
- Check for any loose, broken or missing cutter teeth and pockets.
- Inspect bolts, hydraulic fittings, wiring harnesses, hoses and equipment for tightness, wear, or leakage. Replace if necessary.
- Inspect dry air filters. REPLACE, if necessary, WITH FACTORY AIR FILTER ONLY (see Maintenance Section for part numbers). Do not blow out or tap on ground. Follow engine manual procedure for removal and replacement. Because of the environment of a stump grinder, air filters need to be inspected and replaced more often than the engine manufacturer recommends.
- Replace inner safety filter when dirty or when the outer air filter has been changed 3 times. Do not blow out the inner safety filter or tap on ground. Do not allow dirt to get into engine when removing filters. Dirt ingestion will cause engine failure and is not warranted.
- Check hydraulic oil **daily**, with engine off and cool, and replenish as necessary. This Carlton stump grinder is equipped with a gauge that shows the level of oil and the temperature of the oil. When filling the tank with oil, the window of the gauge will also fill with oil, as the level gets higher in the tank. Never fill the oil tank above the **BLACK** line at the top of the gauge. Do not run the machine with the oil level below the **RED** line at the bottom of the gauge.
- Check condition of tires. Inflate to proper pressure.
- Grease cutter wheel and jackshaft bearings daily. Purge bearings until new grease is seen.



INCORRECT POSITION



CORRECT POSITION



OIL LEVEL/TEMP  
 GAUGE



ENGINE CONTROLS - Refer to engine manufacturers owners' manual for controls, operation, and service.

- The **Key Switch** for starting the engine is located on the Vanguard engine. There is also a choke lever and throttle lever on the engine. Read the engine manual for proper starting and operating instructions.

**DO NOT OPERATE THE ENGINE AT AN ANGLE GREATER THAN 25° OR SEVERE ENGINE DAMAGE WILL OCCUR. PROPER ENGINE OIL LEVEL MUST BE MAINTAINED TO ACHIEVE MAXIMUM ANGLE OF OPERATION OF 25°. (See Engine Owner's Manual for proper oil level.)**

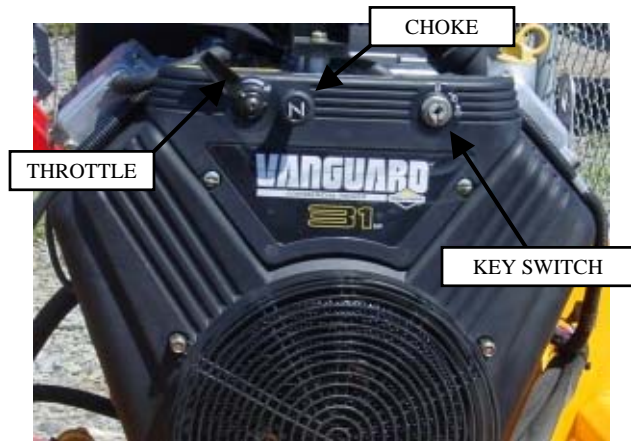

**HYDRAULIC CONTROLS**

- A series of hydraulic controls are located on the machine and are clearly marked.

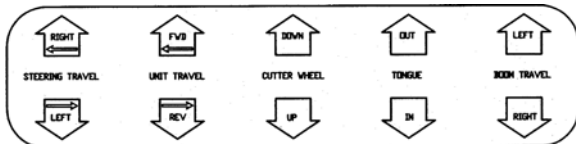

**STEERING TRAVEL - (lever 1)**

- Push or pull control lever to control steering, right or left.



**UNIT TRAVEL** - (lever 2)

- Push or pull control lever to control travel, forward or reverse. This lever controls the dual drive motors on the rear wheels.



The Cutter Head may be moved in any of three directions.

**CUTTER WHEEL (Lift)** - (lever 3)

(Shown as CUTTER HEAD –UP/DOWN on radio transmitter.)

- This lever operates the cutter head lift function, which raises and lowers the cutter head.



**TONGUE** - (lever 4)

- This lever operates the tongue extension function, which moves the machine toward the stump and pulls the machine back away from the stump.



**BOOM TRAVEL (Swing)** - (lever 5)

(Shown as CUTTER HEAD –RIGHT/LEFT on radio transmitter.)

- This lever operates the cutter head swing function, which swings the boom back and forth in a left-right-left-right-left... motion.



## GROUND STAKE

- Pushed firmly into the ground, the stake anchors the machine against pressure during cutting. Provides a “push point” for tongue extension. **Ground stake must be used during operation. The hydraulic motor will not keep machine from creeping while grinding stump.** After stake is in ground, place machine in freewheel position.



## CUTTER WHEEL ENGAGEMENT LEVER

**Never start engine with cutter wheel engaged.** With engine at idle, raise the engine slide lock, and slowly move the engagement lever towards the front of the machine to engage drive belts. **DO NOT ENGAGE OR DISENGAGE BELTS AT HIGH ENGINE SPEED. Injury and damage will occur.**



ENGAGEMENT LEVER

## ENGINE SLIDE LOCK

Using your thumb move the engine slide lock brace and raise the engine slide lock handle. This will unlock the engine slide and allow you to engage the cutter wheel.

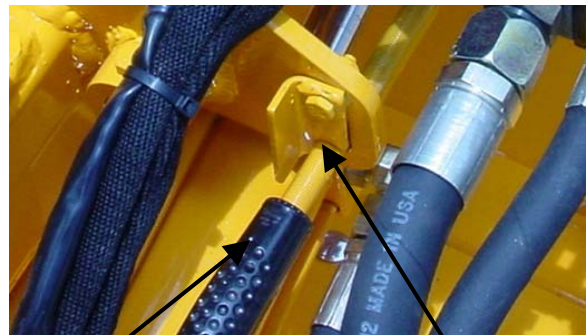

SLIDE LOCK HANDLE

SLIDE LOCK BRACE







**GEAR SELECTOR**

- Push switch up to run machine at high gear and push switch down to run machine at low gear. Machine has more climbing power in low gear. **MUST BE IN HIGH GEAR TO CHANGE INTO FREEWHEEL.**

**FREEWHEELING VALVE**

- Releases wheels from the drive system by overriding the hydraulics. To engage, push knob in and turn a quarter turn counter-clockwise. Tongue extension can be accomplished by setting the lever to freewheeling position. **Always make sure that the ground stake is in the ground before placing machine in free wheel.** To disengage freewheel, push knob in and turn clockwise back to original position. Knob will pop out when freewheeling is disengaged. **FREEWHEEL WILL ONLY OPERATE WITH GEAR SELECTOR IN THE HIGH POSITION.**

**TRAVEL SPEED ADJUSTMENT**

- Adjust travel speed for smooth operation. Turn valve counter-clockwise to decrease travel speed.

**SWING SPEED ADJUSTMENT**

- Adjust swing speed for smooth operation. Turn valve counter-clockwise to slow cutter head swing. Close valve by turning clockwise to allow head to move side to side at low RPM.



## OPTIONAL 4-WHEEL DRIVE AND BLADE FUNCTIONS

If a machine is ordered as a 4-wheel drive unit, it will come with drive motors on the front as well as the rear wheels. The 4-wheel drive unit can also be supplied with a Blade option. The following is the control operation information about these optional functions.

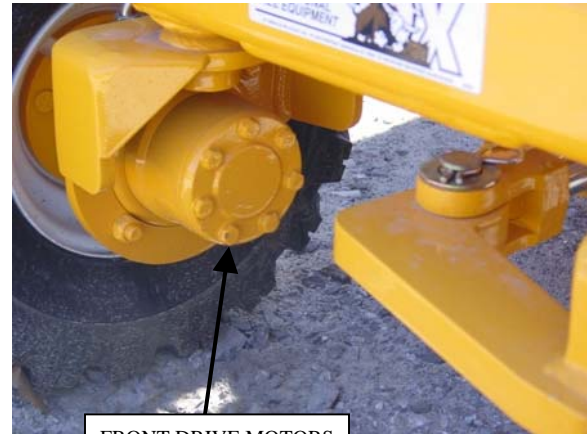

FRONT DRIVE MOTORS

### STEERING TRAVEL - (lever 1)

- Push or pull control lever to control steering, right or left. The steering travel function will operate in the same manner but the machine will look slightly different, as shown in the picture to the right.



### UNIT TRAVEL - (lever 2)

- Push or pull control lever to control travel, forward or reverse. This lever controls the four drive motors on the front and rear wheels.



### BLADE - (lever 4) (Optional)

- This lever operates the blade function, which moves the scrape blade up and down. To backfill the hole after grinding the stump, lower the scrape blade by pulling the lever back. At all other times keep the scrape in the raised position.



**OPTIONAL REMOTE CONTROL**

**OPERATION – WIRED**

- The control functions operate the same on a remote control machine as they do on a standard machine. Instead of having the machine mounted control levers as described earlier in this section, there are toggle switches on the machine control box and on the remote control unit. The toggle switches on the machine control panel can be used to operate the machine for short-term operation to position the machine or to test the operation of the functions.
- Use the switches on the remote transmitter to operate the machine when moving the machine to the job site and when grinding the stumps. For a remote control machine with a wired remote transmitter, turn the **Machine ON/Remote ON** switch to **Remote On** and turn the **Engine** switch on the transmitter to **RUN**. Now start the engine using the key switch, run the engine a few minutes to allow the oil to circulate before starting to operate the functions. After the engine has been running for a few minutes, test the remote transmitter by testing the functions for correct operation. After testing the functions and everything is operating correctly, proceed to the job site.
- Some functions require using the machine mounted controls, such as the Swing Speed Adjustment Valve, the Ground Speed Adjustment Valve, the Freewheel Valve on machines equipped with freewheel motion, and the Engagement Lever to engage the cutter wheel. The Swing Speed Adjustment, Freewheel, and Ground Speed Adjustment Valves are on opposite sides of the machine from the standard machine but still operate the same.

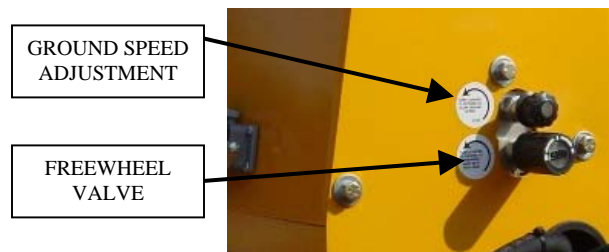
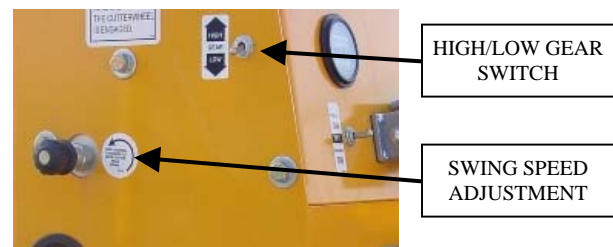
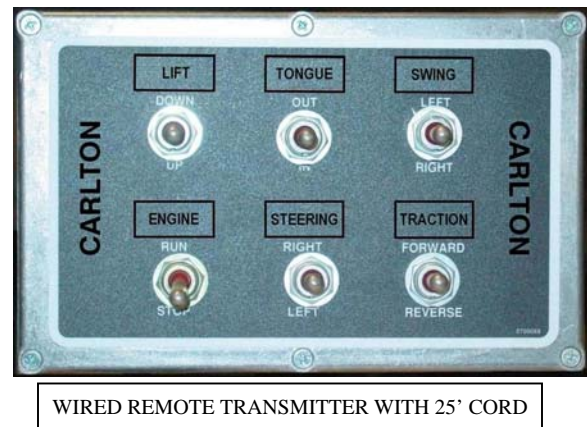
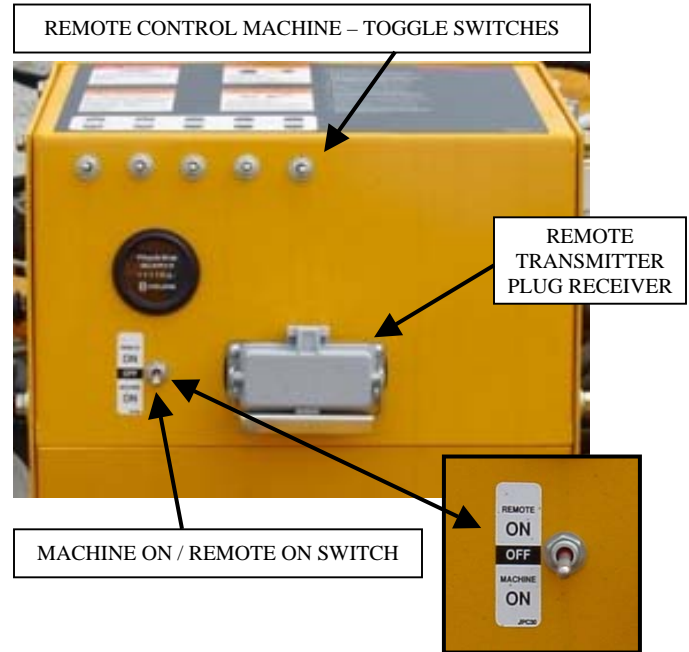

**SAFETY**

- **NEVER SERVICE A MACHINE WITH THE ENGINE RUNNING, SEVERE PERSONAL INJURY COULD OCCUR. TURN ENGINE OFF THEN REMOVE IGNITION KEY AND DISCONNECT POSITIVE BATTERY CABLE TO AVOID STARTING MACHINE ACCIDENTALLY.**
- **CUTTER WHEEL MUST BE DISENGAGED BEFORE TURNING ENGINE ON/OFF AND BEFORE SERVICING A MACHINE. OTHERWISE SEVERE PERSONAL INJURY COULD OCCUR AS WELL AS MACHINE DAMAGE.**
- **ALL MACHINE PARTS MUST COME TO A COMPLETE STOP AND HAVE TIME TO COOL COMPLETELY BEFORE SERVICING A MACHINE OR SEVERE INJURY COULD OCCUR, POSSIBLY SERIOUS BURNS AND/OR DISMEMBERMENT.**
- **PLACE THE CUTTER WHEEL ON THE GROUND WHEN PERFORMING SERVICE ON A MACHINE.**

**OPTIONAL REMOTE CONTROL**

**CONVERTING FROM WIRED TO RADIO TRANSMITTER**

- To change from a wired to a radio (wireless) transmitter, remove the lower cover on the control box. There are 2 bolts on each side.
- You can now see the wired remote control receiver. Remove the receiver cover. Drill holes in this cover for attaching the radio control receiver; make sure the hole locations match the bolt locations on the radio receiver.
- Bolt the radio receiver to the cover and then replace the cover on the wired remote receiver inside the control box.
- Use the wiring and connector diagrams, in the radio control manual included at the back of this manual, to wire directly to the appropriate contacts of the machine electronics. Contact your Carlton dealer if you need assistance not the radio control manufacturer.
- The radio transmitter and receiver will be programmed at the factory when purchased as a set.

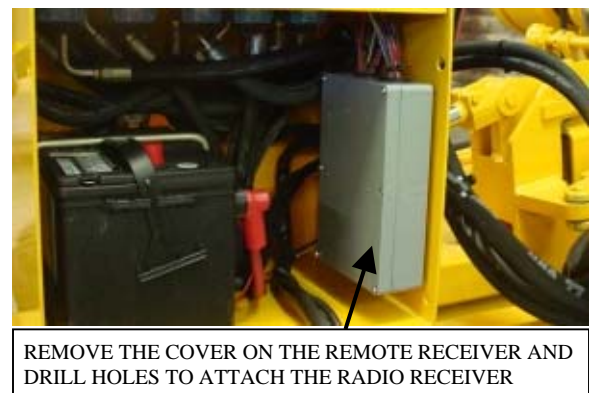

THE RADIO CONTROL RECEIVER, SHOWN AT THE RIGHT, MUST BE INSTALLED IN THE CONTROL BOX



**OPERATION – WIRELESS**

- THE CUTTER WHEEL MUST BE DISENGAGED BEFORE STARTING THE MACHINE.
- To start the engine and radio control transmitter, follow these instructions.
- On the machine, turn the ignition key switch to ON (see engine picture below right), the machine switch to **Remote On**, and make sure the Gear switch is in the HIGH position.
- On the transmitter, press the **E-STOP** button down.
- Toggle any switch on the transmitter.
- Twist the **E-STOP** button clockwise to release. Release the E-STOP button within 10 seconds to power up or the unit will power down. When the transmitter is operating there is a yellow light that will be flashing, the light is indicated in the picture at the right. (Read the radio control manual for more information on the meaning of different lights and colors.) If the transmitter doesn't start, check the transmitter for stuck switches, it will not start with a switch in the ON position.
- Now start the engine using the key switch. If the engine doesn't start right away and you have to restart it, make sure the light on the transmitter is still on, and restart the engine. If you lose the connection (light off), repeat the procedure from the beginning and perform each step exactly as described. Test controls for proper operation.
- The E-STOP button turns off the transmitter and the machine when it is pressed down.
- When the Gear switch is toggled up to HIGH, it only operates when the Travel function is being used.

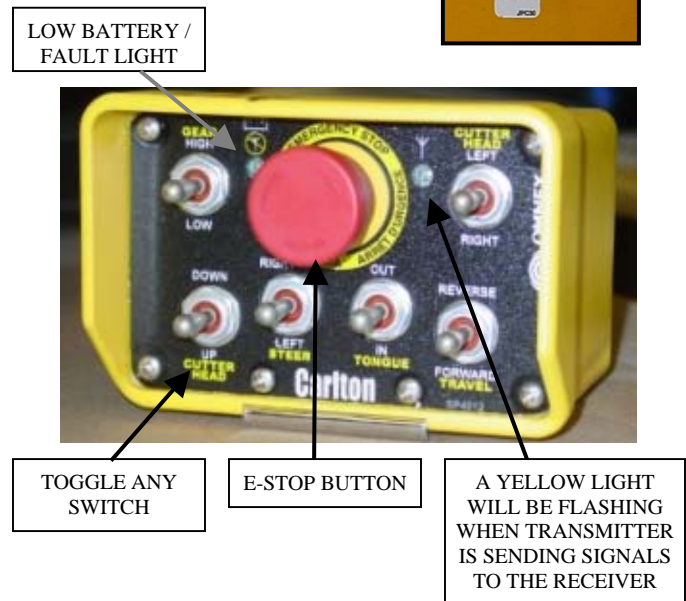
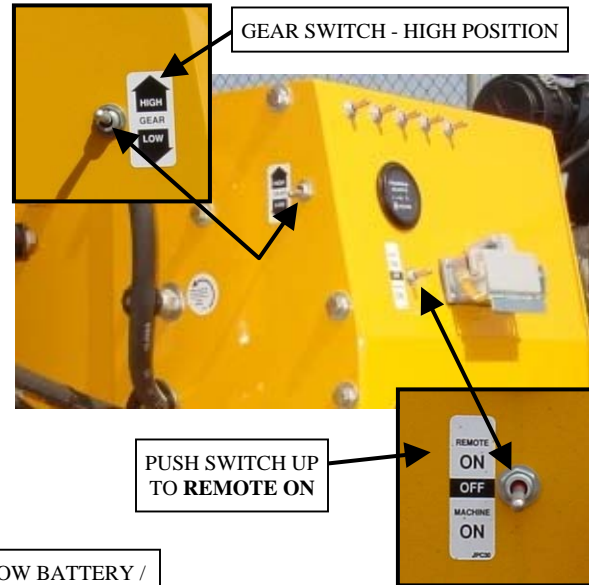

**NEVER WELD ON A MACHINE WITH RADIO CONTROLS WITHOUT FIRST DISCONNECTING THE RECEIVER WIRE HARNESS, OTHERWISE THE RADIO RECEIVER WILL BE DESTROYED.**

**PROGRAMMING – WIRELESS**

- If there is a problem with the receiver or the transmitter and either has to be replaced, you will need to program the new unit to communicate with the existing unit. Or if you have more than one transmitter for this machine, it will need to be programmed to communicate with the existing receiver.
- To program the transmitter and receiver, you have to download the transmitter's unique code into the receiver. There are complete instructions along with colored illustrations in the radio control manual included in the back of this manual.
- To access the receiver, remove the front cover from the machine control box.
- Remove the cover of the remote receiver with the radio receiver attached. This will make it easier to work with the radio receiver. Remove the radio receiver panel by unlatching the plastic tabs on either side of the receiver; see the radio control manual in this manual in the back. The receiver panel will now slide out of the cap.
- Follow the instructions in the radio control manual to download the ID Code. There are specific instructions that need to be followed and corresponding illustrations. The radio control manual is included in the back of this manual.
- Push the receiver panel back up into the cap until the tabs snap back into place.
- Always replace the machine cover when maintenance or troubleshooting is complete. **DO NOT RUN MACHINE WITHOUT ALL GUARDS & COVERS IN PLACE AND SECURED.**



REMOVE COVER



RELEASE THE RADIO RECEIVER CAP BY UNLATCHING THE TABS ON EACH SIDE

REMOVE THE REMOTE COVER TO ACCESS THE RADIO RECEIVER UNIT

**TROUBLESHOOTING**

**SEE THE RADIO CONTROL MANUAL FOR ANY OPERATING PROBLEMS WITH THE RADIO RECEIVER & TRANSMITTER**

(Included in the back of this manual)

- First check the batteries to make sure they are providing enough power to operate the transmitter.
- There is a low battery light on the transmitter, when it starts flashing you have approximately 10 hours of operation left.
- Remove the back cover on the transmitter. Remove old batteries and replace with new batteries. The transmitter operates using 4 AA alkaline batteries.
- Next, open the cover on the machine control box. You will need to be able to see the lights on the receiver to compare to the trouble indicators on the receiver diagnostic list in the radio control manual. Check the light configuration and compare it to the Receiver Diagnostic list in the radio control manual.
- If status light on radio receiver is flashing red, a fuse is blown. To change a fuse, remove the receiver panel from the cap and change the fuse. Inspect wiring for short circuits (e.g. bare wires). If problem re-occurs, call for service. Push the receiver panel back up into the cap until the tabs snap back into place.
- Always replace the machine cover when maintenance or troubleshooting is complete. **DO NOT RUN MACHINE WITHOUT ALL GUARDS & COVERS IN PLACE AND SECURED.**

LOW BATTERY LIGHT



REMOVE THE BACK COVER TO ACCESS THE BATTERIES – THERE ARE 4 SCREWS HOLDING IT IN PLACE. THE BATTERY COMPARTMENT IS LABELED FOR CORRECT BATTERY ORIENTATION.



REMOVE COVER



COMPARE THE LIGHT CONFIGURATION ON THE RECEIVER TO THE DIAGNOSTIC CHART IN THE RADIO CONTROL MANUAL



REPLACE FUSE

**DO NOT TOW! THE MODEL SP4012 IS DESIGNED TO BE TRANSPORTED TO THE JOB SITE AND WILL MOVE UNDER ITS OWN POWER ONCE ON SITE.**

**Transport machine in a suitable vehicle designed for a load of these dimensions and weight. A low trailer is recommended due to its decreased entry height, and will be safer all around. Always use safety tie down straps while transporting.**

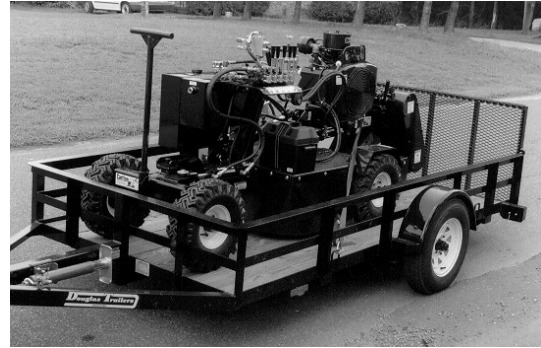

The model SP4012 can be loaded into a pick-up truck, but requires increased safety precautions against tipping. Tie-downs, a sturdy and stable loading ramp and extra caution are required.

- **LOADING RAMPS MUST BE STURDY AND ATTACHED TO THE TRANSPORT VEHICLE BEFORE ATTEMPTING TO LOAD\UNLOAD THIS MACHINE.**
- **TRAILER MUST BE SECURELY ATTACHED TO TOW VEHICLE BEFORE LOADING OR UNLOADING THE STUMP GRINDER.**
- Check trailer for security and make sure chains are properly installed.
- Check tires inflation.
- Check towing lights for proper operation
- Never transport with machine motor running.
- Towing will affect handling. Allow for extra stopping distances.
- Start and stop gradually.
- Tow at a safe reasonable speed. Obey posted speed limits.



## LOADING

- **TRAILER MUST BE SECURELY ATTACHED TO TOW VEHICLE BEFORE LOADING OR UNLOADING THE STUMP GRINDER.**
- **DO NOT LOAD OR UNLOAD ON ANYTHING OTHER THAN LEVEL GROUND.**
- Check valve to make sure machine is **NOT** in freewheeling mode. (See Machine Controls section for more information on freewheeling operation.)
- Start engine as recommended by the engine manufacturers manual.
- Increase engine RPM, and raise cutter head just off the ground.
- With operator in position, push the forward travel control lever and steer machine slowly up appropriate ramp into transport vehicle. **KEEP MACHINE AS LEVEL AS POSSIBLE.**
- Continually adjust cutter head height as you go, keeping the mass as low to the ground as possible.
- Once the machine is loaded, lower the cutter head, shut down engine and secure machine tightly with sufficient tie-downs to prevent any movement in transit.

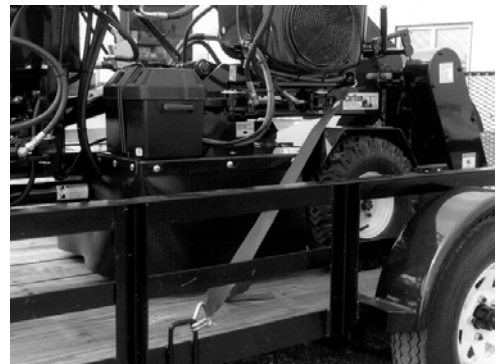

## UNLOADING

- **TRAILER MUST BE SECURELY ATTACHED TO TOW VEHICLE BEFORE LOADING OR UNLOADING THE STUMP GRINDER.**
- **DO NOT LOAD OR UNLOAD ON ANYTHING OTHER THAN LEVEL GROUND.**
- Freewheeling valve **MUST** be in “drive” position to avoid machine runaway on ramp. (See Machine Controls section for more information on freewheeling operation.)
- Undo tie down straps and check ramps for sturdiness and positioning.
- Start engine as recommended by the engine manufacturers manual.
- Increase engine RPM, and raise cutter head to just clear deck and/or ramp.
- Continually adjust cutter head height as you go, keeping the mass as low to the ground as possible.
- Proceed to work site using extreme caution on hills or uneven terrain.



**STARTING – READ ENGINE MANUFACTURERS OWNERS’ MANUAL BEFORE STARTING.**

- Check all fluids before starting.
- Belts must be disengaged before starting.
- Inspect all connections, teeth, tires, etc. (see Daily Checklist).
- Start engine at half speed and allow sufficient time for oil to circulate before proceeding. (See Machine Control section for starting the machine with a remote or radio control transmitter.)
- Test controls for proper operation.
- Avoid transverse slopes. Ascend/descend hills straight up and down. A hydraulic safety valve prevents the machine from picking up speed downhill. This may also be used as a brake by decreasing engine speed.
- Hydraulic motor **will not** hold machine as a parking brake. Machine will creep.
  
- **DO NOT OPERATE THE ENGINE AT AN ANGLE GREATER THAN 25° OR SEVERE ENGINE DAMAGE WILL OCCUR. PROPER ENGINE OIL LEVEL MUST BE MAINTAINED TO ACHIEVE MAXIMUM ANGLE OF OPERATION OF 25°. (See Engine Owner’s Manual for proper oil level.)**
- **DO NOT OPERATE AROUND WATER, GAS, POWER, OR PHONE LINES. IF IN DOUBT, CHECK BEFORE GRINDING.**
- **WEAR FACE SHIELD AND HEARING PROTECTION.**
- **KEEP CLEAR OF CUTTER WHEEL AND MOVING MACHINE PARTS.**
- **KEEP SPECTATORS AWAY.**

- Position machine at stump with cutter wheel a slight distance away from stump. **Do not engage cutter wheel when positioning machine near stump. Hitting the stump with cutter wheel running will break the Poly Chain® belt.**



- Remove clip and position ground stake as far into the earth as possible. Drive in with hammer if necessary.



- Reduce engine RPM to idle.
- Raise cutter head clear of stump.
- Engage cutter wheel belts by raising engine slide lock and then slowly pushing engagement lever toward front of machine. When the cutter wheel is fully engaged the engine slide lock will be in a raised position.
- Increase engine RPM to full.
- Test controls for proper operation, speed, and unobstructed movement.

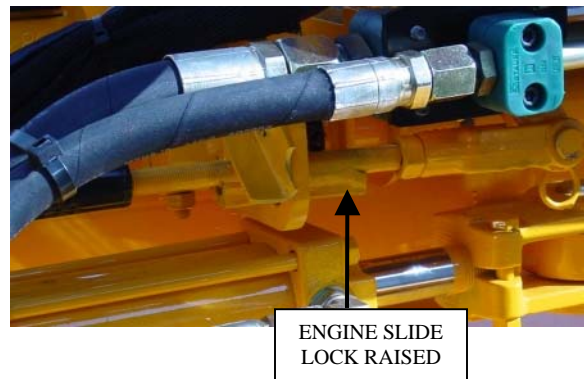
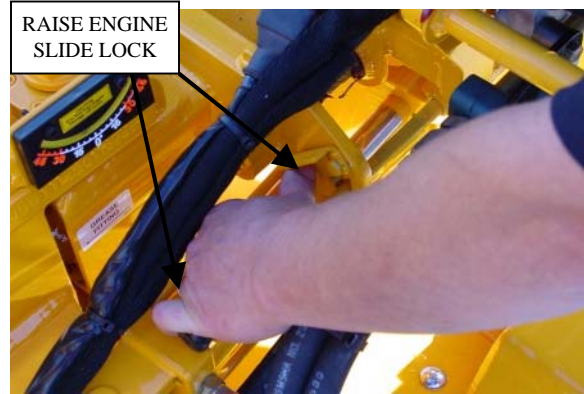

- Cutter head swing speed should be adjusted to a rate that will allow cutter wheel to pass through stump smoothly. If jerking, bouncing, or significant drops in engine speed occur, swing rate is too rapid and must be decreased.
- Swing speed should be determined and adjusted with the controls in the full open position.
- A counter-rotating valve is located within the hydraulic system to adjust this speed. Turning the handle counter-clockwise will open the bypass and slow swing action. Turning it clockwise will close the valve and increase swing rate.

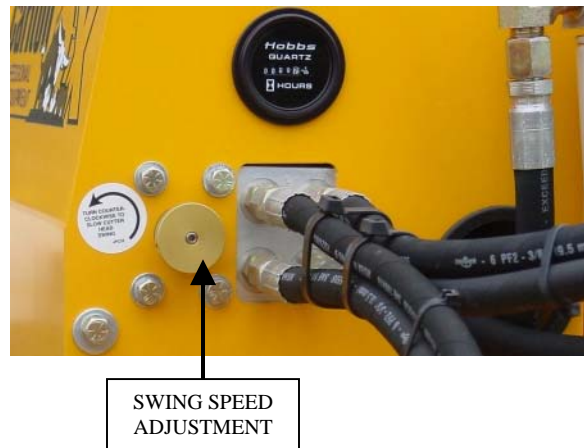

- Lower spinning cutter wheel to stump and make a few light passes at stump to get a feel for the cutting action.
- Gradually increase cutting action and work away at stump by swinging cutter wheel left-to-right-to-left through stump in a sideways motion. Smooth, effortless cutting lengthens machine life, minimizes downtime, and is more profitable in the long run.
- Continue cutting stump by adjusting cutter wheel progressively lower until stump is cut well below ground level.
  
- Raise cutter wheel and swing clear of stump then extend tongue to position machine closer to stump for next series of passes. Lower cutter wheel and continue cutting.
- Continue in this manner until stump has been removed.
- Larger stumps may require repositioning machine to work at best advantages.
  
- Raise cutter wheel clear of stump and return to center position.
- Reduce engine speed to idle. **DO NOT TURN MOTOR OFF.** Engine must be allowed to cool slowly at idle for 3 – 5 minutes to avoid damage.
- With engine speed at idle; disengage drive belts by slowly pushing the engagement lever back toward the cutter wheel. The engine slide will lock automatically when belt is disengaged.
- **DO NOT DISENGAGE DRIVE BELTS AT A HIGH ENGINE SPEED.** Damage to belts and machine will occur.
- Allow cutter wheel to come to a full stop before inspecting work area.
- Retract tongue extension; take machine out of freewheel control and pull the tongue stake out of the ground.
- Turn motor off.



**SAFETY**

- **NEVER SERVICE A MACHINE WITH THE ENGINE RUNNING, SEVERE PERSONAL INJURY COULD OCCUR. TURN ENGINE OFF THEN REMOVE IGNITION KEY AND DISCONNECT POSITIVE BATTERY CABLE TO AVOID STARTING MACHINE ACCIDENTALLY.**
- **CUTTER WHEEL MUST BE DISENGAGED BEFORE TURNING ENGINE ON/OFF AND BEFORE SERVICING A MACHINE. OTHERWISE SEVERE PERSONAL INJURY COULD OCCUR AS WELL AS MACHINE DAMAGE.**
- **ALL MACHINE PARTS MUST COME TO A COMPLETE STOP AND HAVE TIME TO COOL COMPLETELY BEFORE SERVICING A MACHINE OR SEVERE INJURY COULD OCCUR, POSSIBLY SERIOUS BURNS AND/OR DISMEMBERMENT.**
- **DO NOT OPERATE A MACHINE WITHOUT A COMPLETE NUMBER OF TEETH IN THE CUTTER WHEEL PROPERLY INSTALLED. EXCESSIVE MACHINE VIBRATION WILL OCCUR CAUSING PREMATURE BEARING FAILURE AND EQUIPMENT DAMAGE.**
- **PLACE THE CUTTER WHEEL ON THE GROUND WHEN PERFORMING SERVICE ON A MACHINE.**

- Check engine oil at dipstick **daily**; take reading with engine **sitting level** (see **photos**). Add recommended oil and change oil as required. (See engine owners' manual.)

**SP4012 Engine Filters**

- 0200141 Oil Filter
- 0200142 Fuel Filter
- 0200102C Air - Main Filter
- 0200102D Air - Safety Filter



INCORRECT POSITION



CORRECT POSITION

- Check hydraulic oil level daily. This Carlton stump grinder is equipped with a gauge that shows the level of oil and the temperature of the oil. When filling the tank with oil, the window of the gauge will also fill with oil, as the level gets higher in the tank. Never fill the oil tank above the **BLACK** line at the top of the gauge. Do not run the machine with the oil level below the **RED** line at the bottom of the gauge.
- The machine is equipped with Citgo AW32 hydraulic oil at the time of manufacture. Use the same or equivalent.
- For a new machine, change the hydraulic oil filter when the stump grinder has been operating for 10 hours. Replace with the same type of in-tank filter element supplied originally, available through Carlton or Carlton dealers. From this point on, change the filter every 200 hours of operation.
- Change hydraulic oil every 500 hours of operation or at least once a year depending on use. Flush the hydraulic tank when changing the hydraulic oil. Replace oil if it has a burnt odor or if it is contaminated. Replace oil if the stump grinder has been stored for a long period of time (all winter).
- Drain the hydraulic tank using the drain plug located on the bottom of the tank. Dispose of used oil according to state regulations.
- Check setscrews in Jackshaft Bearings and Cutter Wheel Bearings for tightness **weekly**.



- Check cutter wheel, pockets, and teeth for wear. If any repair is needed, see “Servicing Cutter Wheel” section for further instruction.



**Always clean tip of grease gun fitting and grease fitting on machine before attaching hose to prevent dirt from being forced into machine parts.**

- Grease jackshaft bearings **Daily**. These bearings should be purged using grease **EVERYDAY**. Purge till new grease comes out. Use Texaco® Starplex II grease. **Always clean tip of grease gun fitting and grease fitting on machine before attaching hose to prevent dirt from being forced into machine parts.**
- Grease cutter wheel bearings **Daily**. These bearings should be purged using grease **EVERYDAY**. Purge till new grease comes out. Use Texaco® Starplex II grease. **Always clean tip of grease gun fitting and grease fitting on machine before attaching hose to prevent dirt from being forced into machine parts.**
- Grease engine slide assembly every 15 – 20 hours of operation with approximately 2 to 4 shots of Texaco® Starplex II grease. (Total of 6 grease fittings.) **DO NOT OVER GREASE.**
- Grease engagement lever every 15 – 20 hours of operation with approximately 2 to 4 shots of Texaco® Starplex II grease.



ENGAGEMENT LEVER  
GREASE FITTINGS

- Clean out Poly Chain® Guard by removing bottom portion of guard **weekly**. **Chip build up will wear Poly Chain® Belt.**



- Grease boom pivot monthly, swing cutter wheel to the right to access grease fitting. Use Texaco® Starplex II grease. **DO NOT OVER GREASE.**

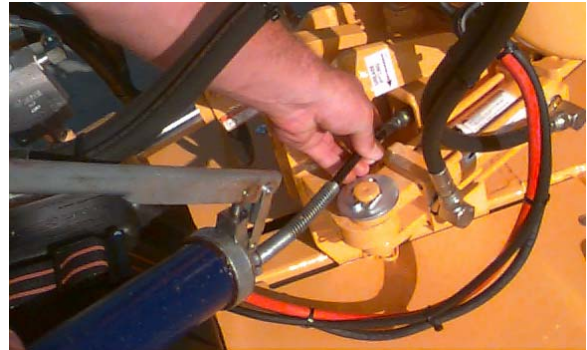

- Grease bottom pivot bearings monthly. Use Texaco® Starplex II grease. You cannot over grease this area all parts are heat-treated.



- Grease steering wheel pivots every 2-3 months. Use Texaco® Starplex II grease. **DO NOT OVER GREASE.**



- Extend the tongue and use a cloth covered with grease to lightly coat the tongue extension every 6 months.





- The model SP4012, as well as all of our machines, is built to be a rugged performer. Your new machine is sturdy and our design goals are simplicity and reliability.
- A regularly scheduled maintenance program will pay big dividends in machine life, performance and avoided downtime.

**Lubrication Schedule**

- Use Texaco® Starplex II grease.

CARLTON MODEL SP4012	Daily	15-20 Hr.	Monthly	2-3 Mon	6 Mon	Special Comments
- TONGUE					▨	Light coating
- ENGINE SLIDE ASSEMBLY		▨				1-2 Shots
- ENGAGEMENT LEVER		▨				1-2 Shots
- BEARINGS						
- Front Wheel Hubs					▨	Disassemble, clean and repack
- Steering Wheel Pivots				▨		Adjust as required.
- Pivot Head Lift			▨			Three fittings underneath machine
- Pivot Head Swing			▨			Adjust as required.
- Cutter Wheel	▨					Purge bearings daily.
- Jackshaft	▨					Purge bearings daily.
<b>ENGINE</b> REFER TO ENGINE MANUFACTURERS MANUAL FOR PROPER ENGINE SERVICING						

SP4012IS-8\_A

COMPLAINT	CAUSE	CORRECTION
Engine will not start. (See Engine Manufacturer Manual for further information.)	<ul style="list-style-type: none"> <li>• Loose ground wire.</li> <li>• Loose hot wire.</li> <li>• Dead battery.</li> </ul>	<ul style="list-style-type: none"> <li>• Clean and tighten.</li> <li>• Clean and tighten.</li> <li>• Recharge or replace.</li> </ul>
Hydraulic system loss of power.	<ul style="list-style-type: none"> <li>• Low oil.</li> <li>• Valve set too low.</li> <li>• Missing or sheared key on pump shaft.</li> <li>• Bad cylinder.</li> </ul>	<ul style="list-style-type: none"> <li>• Refill with correct oil.</li> <li>• Adjust relief valve.</li> <li>• Remove pump, replace or repair keyway.</li> <li>• Replace cylinder packing.</li> </ul>
Swing cylinder loss of power.	<ul style="list-style-type: none"> <li>• Cutter head speed adjustment screw turned wide open.</li> </ul>	<ul style="list-style-type: none"> <li>• To slow cutter head swing at high RPM turn valve counter-clockwise.</li> <li>• Re-adjust for “no bounce” cutting.</li> </ul>
Belt Squeal.	<ul style="list-style-type: none"> <li>• Belt tension too loose.</li> <li>• Belt out of line.</li> </ul>	<ul style="list-style-type: none"> <li>• Tighten.</li> <li>• Align Pulleys.</li> </ul>
Belt jumping off.	<ul style="list-style-type: none"> <li>• Engaging or disengaging belt at high engine RPM.</li> <li>• Belt keeper too far from belt.</li> </ul>	<ul style="list-style-type: none"> <li>• Only engage or disengage belts at low engine speeds.</li> <li>• Adjust keeper closer to belt.</li> </ul>
Cutter wheel vibration.	<ul style="list-style-type: none"> <li>• Tooth missing.</li> <li>• Pocket out of balance.</li> <li>• Improper tooth arrangement.</li> </ul>	<ul style="list-style-type: none"> <li>• Replace missing teeth.</li> <li>• Always replace pockets in pairs across from each other.</li> <li>• Install correctly with like pairs of teeth directly across from each other.</li> </ul>
Cutter wheel throwing teeth.	<ul style="list-style-type: none"> <li>• Bad pocket.</li> <li>• Dirt in pocket</li> <li>• Worn cutter wheel</li> </ul>	<ul style="list-style-type: none"> <li>• Replace pocket.</li> <li>• Clean pocket and replace missing teeth.</li> <li>• Replace cutter wheel</li> </ul>
Cutter wheel breaking teeth.	<ul style="list-style-type: none"> <li>• Teeth set too far out of pocket.</li> </ul>	<ul style="list-style-type: none"> <li>• Use gauge to set teeth correctly.</li> </ul>

COMPLAINT	CAUSE	CORRECTION
Cutter wheel stops turning.	<ul style="list-style-type: none"> <li>• Belt not engaged.</li> <li>• Engine belt broke.</li> <li>• Poly chain® belt broke.</li> <li>• Sheared key in shaft.</li> <li>• Broke cutter wheel shaft.</li> </ul>	<ul style="list-style-type: none"> <li>• Adjust yoke assembly.</li> <li>• Replace belt.</li> <li>• Replace belt.</li> <li>• Replace key.</li> <li>• Replace shaft.</li> </ul>
Roar in machine when cutter wheel is engaged.	<ul style="list-style-type: none"> <li>• Belt guards rubbing on jackshaft or cutter wheel shaft.</li> <li>• Jackshaft or cutter wheel bearings going bad.</li> </ul>	<ul style="list-style-type: none"> <li>• Re-position guards off of shafts.</li> <li>• Replace bearings.</li> </ul>
Traction loss of power.	<ul style="list-style-type: none"> <li>• Open free wheel valve.</li> <li>• Worn free wheel valve.</li> <li>• Relief valve set too low.</li> <li>• Hydraulic motor worn.</li> </ul>	<ul style="list-style-type: none"> <li>• Close free wheel valve.</li> <li>• Replace free wheel valve.</li> <li>• Increase relief valve pressure by turning relief valve screw inward.</li> <li>• Replace Hydraulic motor.</li> </ul>
Bearing will not take grease.	<ul style="list-style-type: none"> <li>• Grease fitting clogged.</li> </ul>	<ul style="list-style-type: none"> <li>• Replace fitting</li> </ul>
Cutter head swings faster one way than the other.	<ul style="list-style-type: none"> <li>• Counter balance valve is out of adjustment.</li> </ul>	<ul style="list-style-type: none"> <li>• Adjust counter balance valve to equalize swing speed.</li> </ul>

**For all Radio Transmitter or Receiver problems, see the Radio Control Manual included at the back of this manual.**

## Replacing V-Belt

### SAFETY

- **NEVER SERVICE A MACHINE WITH THE ENGINE RUNNING, SEVERE PERSONAL INJURY COULD OCCUR. TURN ENGINE OFF THEN REMOVE IGNITION KEY AND DISCONNECT POSITIVE BATTERY CABLE TO AVOID STARTING MACHINE ACCIDENTALLY.**
- **CUTTER WHEEL MUST BE DISENGAGED BEFORE TURNING ENGINE ON/OFF AND BEFORE SERVICING A MACHINE. OTHERWISE SEVERE PERSONAL INJURY COULD OCCUR AS WELL AS MACHINE DAMAGE.**
- **ALL MACHINE PARTS MUST COME TO A COMPLETE STOP AND HAVE TIME TO COOL COMPLETELY BEFORE SERVICING A MACHINE OR SEVERE INJURY COULD OCCUR, POSSIBLY SERIOUS BURNS AND/OR DISMEMBERMENT.**
- **DO NOT OPERATE A MACHINE WITHOUT A COMPLETE NUMBER OF TEETH IN THE CUTTER WHEEL PROPERLY INSTALLED. EXCESSIVE MACHINE VIBRATION WILL OCCUR CAUSING PREMATURE BEARING FAILURE AND EQUIPMENT DAMAGE.**
- **PLACE THE CUTTER WHEEL ON THE GROUND WHEN PERFORMING SERVICE ON A MACHINE.**

- Remove V-belt guard cover, which is held on with ten bolts.



- Belt should be disengaged. If it isn't, push the engagement lever back toward the cutter wheel as far as it will go. Engine slide will lock automatically when the belt is disengaged. Belt will be loose when disengaged.



- Remove pump drive. **Only remove the bolts at 12 o'clock and 6 o'clock.** Remove the pump plate with the pump still attached, not necessary to remove and cap hoses.



## Replacing V-Belt

- When you pull the pump off, the pump coupler and a rubber insert will come off with it. Take note of the insert and do not lose it.

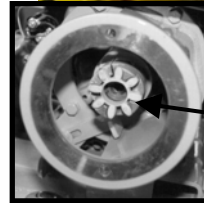
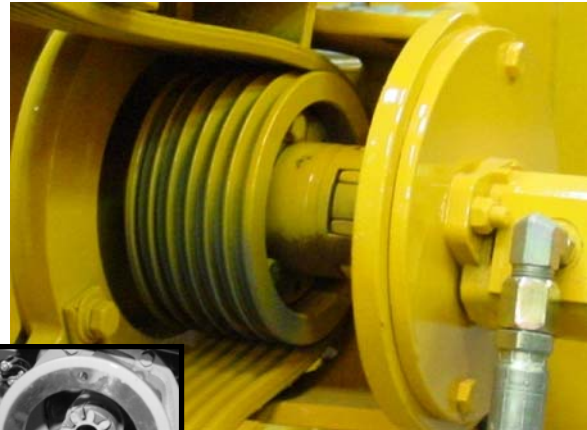

KEEP RUBBER INSERT  
TO PUT BACK INTO COUPLER

- Loosen, don't remove, all belt-keepers to remove the engine belt. There are two belt keepers on the jackshaft sheave. The beehive has two belt keepers inside it, one on top and one on bottom. The last belt keeper is beside the beehive.

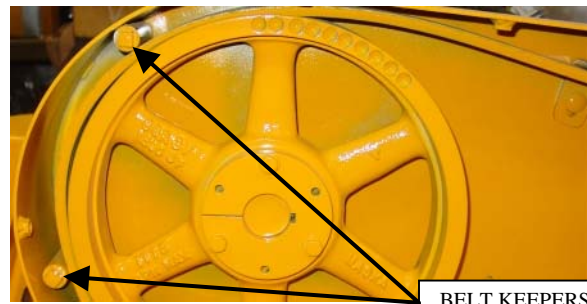

BELT KEEPERS

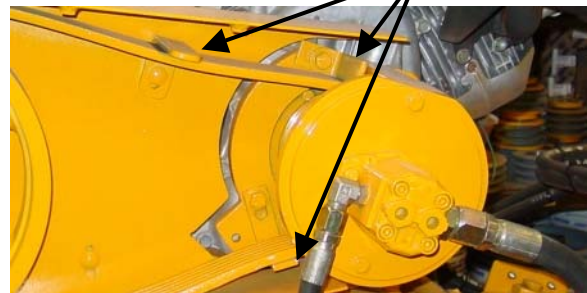

- Remove and replace the engine belt.



## Replacing V-Belt

- After replacing belt, check it for tension.
- Engage belt using the engagement lever. Raise the engine slide lock and push the engagement lever toward the front of the machine as far as it will go. Check belt tension. **When the V-belt is tensioned properly, it will deflect 1/4" with 25 lbs. of force applied to the center of the belt between the sheaves.** New belts will stretch and become loose as machine runs. Check belt tension often when belts are new.
- Disengage the belt. **DO NOT START THE ENGINE.** If any adjustment is required, there is a linkage assembly below the engagement handle on the operator side. Loosen jam nut and adjust clevis with wrench turning up toward machine. This will make engine slide further and will tighten the belt. Make only slight adjustments at a time and recheck tension; repeat as necessary until tension is correct. Once tightness is achieved, tighten jam nut back onto clevis.
- Use this same procedure to tighten loose belts.
- **DO NOT OVER TIGHTEN BELTS; OVERLY TIGHT BELTS CAN CAUSE BEARING AND ENGINE DAMAGE.** Turn the clevis down with a wrench if the belt is too tight. Make only slight adjustments at a time and recheck tension; repeat as necessary until tension is correct.
- Replace belts when worn or when repeated adjustments are necessary. Belts should never get so loose that all of the adjustment capability is used.
- Check to make sure the sheaves are still aligned. Place a straight edge against both sheaves to check alignment. If the sheaves were not removed or loosened, they should still be aligned.

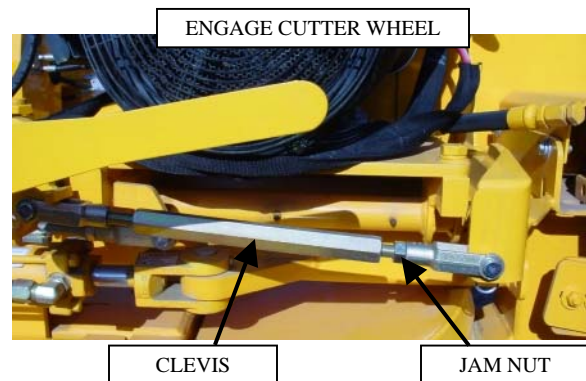

## Replacing V-Belt

- If the belt tension was adjusted, the engine slide lock will also have to be adjusted. This locks the engine in the disengaged position so that the cutter wheel will not accidentally engage. When adjusting the engine slide lock, turn the clevis clockwise to shorten the length of the engine slide lock when the engagement linkage was lengthened. The engagement linkage would be lengthened to put more tension on the belt. Lengthen the engine slide lock if the engagement linkage was shortened.
- Replace hydraulic pump making sure the insert is in place.
- Retighten all five belt-keepers when the belt tension has been adjusted. There are two belt keepers on the jackshaft sheave. The beehive has two belt keepers inside it, one on top and one on bottom. The last belt keeper is beside the beehive.

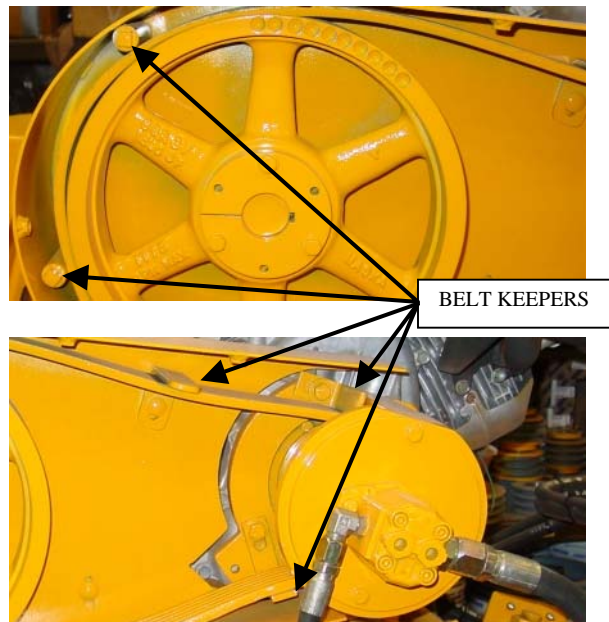
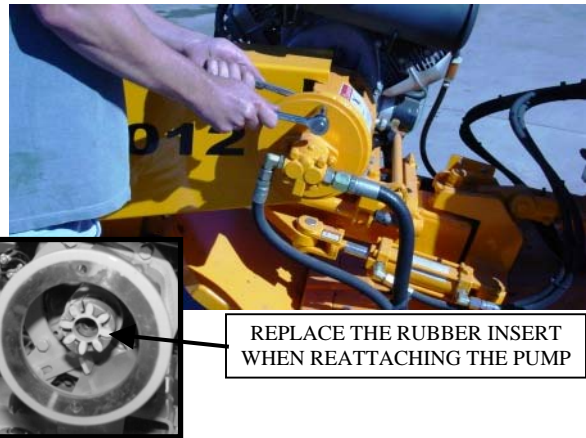

## Replacing V-Belt

- Replace V-belt guard cover and tighten bolts. **DO NOT RUN MACHINE WITHOUT ALL GUARDS IN PLACE AND SECURED.**



## GENERAL TENSIONING OF V-BELT DRIVES

Tensioning of belts on the V-belt drive is critical. A few simple rules about tensioning will satisfy most of your requirements:

1. The best tension for the V-belt drive is the lowest tension at which the belts will not slip under the highest load condition.
2. Check the tension on a new drive frequently during the first day of operation.
3. Thereafter, check the drive belt tension periodically.
4. Too much tension shortens belt and bearing life.
5. Keep belts and sheaves free from any foreign material that may cause slippage.



## Replacing Poly Chain® Belt

### SAFETY

- **NEVER SERVICE A MACHINE WITH THE ENGINE RUNNING, SEVERE PERSONAL INJURY COULD OCCUR. TURN ENGINE OFF THEN REMOVE IGNITION KEY AND DISCONNECT POSITIVE BATTERY CABLE TO AVOID STARTING MACHINE ACCIDENTALLY.**
- **CUTTER WHEEL MUST BE DISENGAGED BEFORE TURNING ENGINE ON/OFF AND BEFORE SERVICING A MACHINE. OTHERWISE SEVERE PERSONAL INJURY COULD OCCUR AS WELL AS MACHINE DAMAGE.**
- **ALL MACHINE PARTS MUST COME TO A COMPLETE STOP AND HAVE TIME TO COOL COMPLETELY BEFORE SERVICING A MACHINE OR SEVERE INJURY COULD OCCUR, POSSIBLY SERIOUS BURNS AND/OR DISMEMBERMENT.**
- **DO NOT OPERATE A MACHINE WITHOUT A COMPLETE NUMBER OF TEETH IN THE CUTTER WHEEL PROPERLY INSTALLED. EXCESSIVE MACHINE VIBRATION WILL OCCUR CAUSING PREMATURE BEARING FAILURE AND EQUIPMENT DAMAGE.**
- **PLACE THE CUTTER WHEEL ON THE GROUND WHEN PERFORMING SERVICE ON A MACHINE.**

Special care needs to be taken with your Poly Chain® belt. Alignment, tension, and cleanliness of this belt are very important. The Poly Chain® belt needs to be checked for tension approximately every 70 to 100 hours of use. The Poly Chain® belt must be running true. If you adjust one bearing more than the other, the belt will run on an angle and will cause belt failure. A belt broken straight across is the result of a shock load. In a shock load failure, the fibers are broken and over a period of time the belt will break down from the shock load and snap in half. A broken belt with lost teeth indicates that the belt was loose. After you have installed or re-tensioned the Poly Chain® belt, you will have to re-adjust the engine V-belts for proper tension.

- Remove the Poly Chain® guard cover and bottom cover.



### Replacing Poly Chain® Belt

- Loosen Poly Chain® belt by moving jackshaft bearings. **MARK THE BEARINGS SO THAT YOU KNOW HOW THEY ARE POSITIONED ON THE JACKSHAFT PLATE.** Loosen bolts on bearing closest to Poly Chain® guard and remove bolts on the bearing closest to engine belt guard so that side of the jackshaft may be raised to remove Poly Chain® belt.
- Loosen the jam bolts in the back and move the bearings back.
- Belt should be disengaged. If it isn't push the engagement lever back toward the cutter wheel as far as it will go. Engine slide should lock automatically when the belt is disengaged; check to make sure it does. (See Machine Controls section for engine slide lock.)
- Remove old belt and replace with new one. **Do not pry new belt over sprockets since this can break the fibers in the Poly Chain® belt.**



### Replacing Poly Chain® Belt

- Check alignment of Poly Chain® sprockets using a straight edge.
- To adjust tension of the belt, slide the bearings back into the place that you had marked. Tighten the jam bolts. To tighten the belts more if needed, loosen the front jam bolts and tighten each of the back jam bolts the same number of revolutions, to keep the alignment true. After the belt is adjusted, tighten the front jam bolts back against the bearing. **After the Poly Chain® belt has been adjusted; check the V-belt tension and alignment. When the V-belt is tensioned properly, it will deflect 1/4" with 25 lbs. of force applied.**
- Replace Poly Chain® belt guard cover and bottom cover and tighten bolts.  
**DO NOT RUN MACHINE WITHOUT ALL GUARDS IN PLACE AND SECURED.**

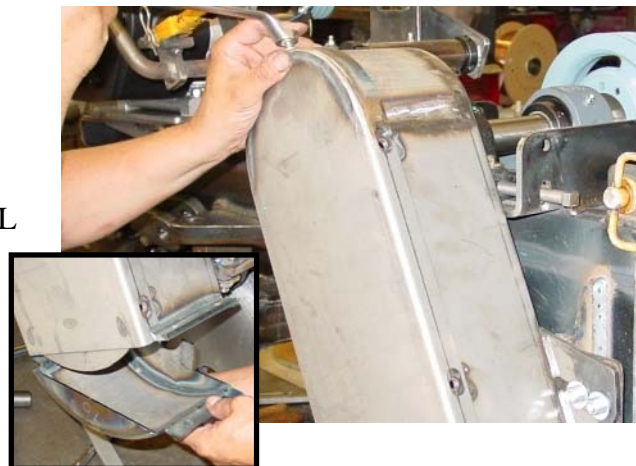

**Replacing Poly Chain® Belt**

**Tensioning Procedure for Gates Poly Chain® GT® Belts**

Gates Poly Chain GT belt's high performance characteristics dictate a need for correct installation tension. The following tables provide the required minimum and maximum deflection forces based on the belt pitch, pitch length, width and center distance. Deflection values are simplified based on full rated horsepower capacity per belt width. For drives not covered by the simplified tables, or drives not using full rated horsepower capacity, refer to Page 67 in Gates Poly Chain GT Drives Manual #17595.

**Step 1:** Based on belt pitch and width, locate the correct table.

**Step 2:** Locate the RPM of your faster shaft (smaller sprocket) in the first column.

**Step 3:** Locate the number of grooves on your small sprocket in the second column.

**Step 4:** Locate the correct column for your belt length (belt lengths shown at the top of each column).

**Step 5:** Under the correct belt length column, locate the center distance for your drive (center of driveR shaft to center of driveN shaft in inches).

**Step 6:** Read down to the intersection for the recommended minimum and maximum deflection force (pounds) for your drive.

**Step 7:** Apply that deflection force range for the appropriate deflection (1/64" per inch of span length). See sketch.

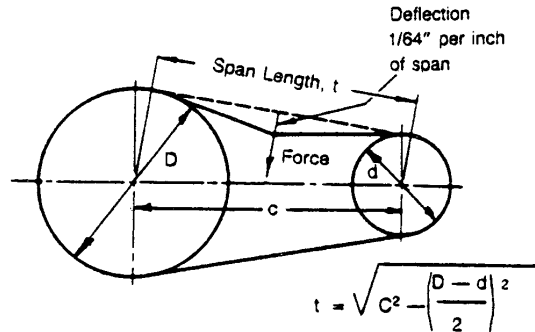

**8M-62 Minimum and Maximum Deflection Force (lbs) for 62 mm Wide Poly Chain GT Belts**

RPM of Faster Shaft	Number of Grooves on Small Sprocket	Center Distance (inches) for Belt Designation																																
		8M-640, 8M-720				8M-800, 8M-896				8M-1000, 8M-1120				8M-1280, 8M-1440				8M-1792, 8M-2000				8M-2240, 8M-2400				8M-2840, 8M-3200				8M-4000, 8M-4480				
		CD <= 8	CD > 8	CD <= 9	CD > 9	CD <= 13.9	CD > 13.9	CD <= 18.5	CD > 18.5	CD <= 23.5	CD > 23.5	CD <= 35.0	CD > 35.0	CD <= 45.0	CD > 45.0	CD <= 65.5	CD > 65.5	Min.	Max.	Min.	Max.	Min.	Max.	Min.	Max.	Min.	Max.	Min.	Max.	Min.	Max.	Min.	Max.	
5000 & Over	22 to 28	21.0	22.5	21.6	22.8	22.6	24.1	23.5	24.9	25.3	27.0	26.3	28.0	27.5	29.6	28.7	30.8	29.7	31.3	31.0	32.9	32.4	34.1	33.0	35.1	34.8	36.1	35.6	38.4	38.0	39.3	37.9	40.3	
	30 to 80	22.2	23.6	22.7	23.0	24.2	26.0	24.6	25.9	28.9	29.1	27.6	29.2	29.0	31.7	30.1	32.1	31.4	32.8	32.4	34.1	34.0	36.0	34.5	36.3	36.4	37.9	37.2	39.6	39.5	40.5	39.6	41.5	
Under 5000	22 to 28	21.6	23.1	22.2	23.2	23.3	24.8	24.2	25.6	26.1	27.8	27.1	28.9	28.4	30.6	29.6	31.9	30.8	32.4	32.1	34.0	33.6	35.3	34.1	36.3	36.1	37.4	36.9	39.8	39.5	40.7	39.3	41.8	
to 4000	30 to 80	22.5	23.4	23.1	23.4	24.6	26.0	25.1	25.9	27.4	29.5	28.2	29.5	29.7	32.3	30.9	32.6	32.3	34.3	33.3	34.8	35.0	36.8	35.5	37.1	37.5	39.0	38.4	40.7	40.8	42.1	40.9	42.7	
Under 4000	22 to 28	22.4	23.8	23.0	23.9	24.2	25.6	25.1	26.4	27.1	28.7	28.1	29.9	29.6	31.7	30.8	33.0	32.1	33.6	33.3	35.2	35.0	36.6	35.5	37.7	37.6	38.9	38.5	41.4	41.1	42.3	41.0	43.4	
to 3200	30 to 80	23.0	24.0	23.7	24.0	25.2	26.3	25.7	26.5	28.2	29.9	29.1	30.1	30.6	33.0	31.9	33.3	33.4	34.9	34.4	35.6	36.1	37.7	36.7	38.1	38.8	39.9	39.8	41.9	42.2	43.3	42.4	44.0	
Under 3200	22 to 28	23.3	24.9	23.9	25.0	25.2	26.8	26.1	27.6	28.2	30.0	29.3	31.2	30.9	33.3	32.1	34.5	33.5	35.3	34.8	36.9	36.5	38.4	37.1	39.5	39.3	40.8	40.2	43.4	43.0	44.4	42.9	45.6	
to 2400	30 to 80	23.8	25.0	24.5	25.0	26.0	27.2	26.6	27.6	29.1	30.9	30.1	31.4	31.6	34.0	33.1	34.7	34.5	36.1	35.6	37.1	37.4	38.3	38.1	39.8	40.1	41.7	41.4	43.8	43.8	45.1	44.2	46.1	
Under 2400	22 to 28	24.4	26.0	25.2	26.1	26.5	28.0	27.5	28.8	29.7	31.4	30.8	32.7	32.5	34.9	33.8	36.1	35.4	37.0	36.6	38.6	38.6	38.5	40.3	39.1	41.3	41.4	42.8	42.4	45.5	45.3	46.5	45.3	47.8
to 1800	30 to 80	24.9	26.1	25.7	26.1	27.1	28.3	27.9	28.9	30.3	32.0	31.5	32.7	33.0	35.4	34.6	36.3	36.0	37.5	37.3	38.8	39.1	41.1	40.0	41.6	42.0	43.6	43.4	45.6	45.9	47.0	46.4	48.2	
Under 1800	22 to 28	25.4	27.0	26.1	27.1	27.5	29.1	28.5	29.9	30.8	32.7	32.0	34.0	33.8	36.3	35.1	37.5	36.8	38.5	38.1	40.1	40.0	41.9	40.8	43.0	43.0	44.6	44.1	47.3	47.1	48.4	47.1	49.7	
to 1400	30 to 80	25.8	27.1	26.6	27.1	28.1	29.4	28.9	30.0	31.4	33.5	32.7	34.0	34.2	36.8	35.9	37.7	37.3	38.9	38.7	40.3	40.5	42.6	41.5	43.2	43.5	45.3	45.1	47.6	47.5	48.9	48.1	50.1	
Under 1400	22 to 28	26.9	28.8	27.7	28.9	29.2	31.2	30.2	31.9	32.7	34.9	33.9	36.2	35.8	38.8	37.2	40.1	39.1	41.2	40.4	42.8	42.5	44.8	43.1	45.9	45.7	47.7	46.8	50.5	49.9	51.8	50.0	53.1	
to 900	28 to 80	27.2	28.9	28.2	28.9	29.7	31.4	30.5	32.0	33.2	35.8	34.8	36.3	36.2	39.2	38.0	40.2	39.5	41.8	40.9	43.0	42.9	45.5	43.9	46.1	46.0	48.4	47.7	50.9	50.3	52.2	51.0	53.5	
Under 900	22 to 28	28.5	30.5	29.3	30.6	30.9	33.0	32.0	33.8	34.6	36.9	35.9	38.4	37.9	41.2	39.3	42.4	41.5	43.8	42.7	45.4	45.0	47.5	45.7	48.6	48.4	50.6	49.6	53.5	52.9	54.8	53.0	56.3	
to 600	30 to 80	28.8	30.6	29.8	30.7	31.4	33.2	32.3	33.9	35.1	37.9	36.5	38.4	38.2	41.5	40.1	42.5	41.8	44.1	43.3	45.5	45.3	48.2	46.4	48.8	48.7	51.2	50.5	53.9	53.2	55.3	54.0	56.7	
Under 600	22 to 28	30.3	32.3	31.1	32.3	32.9	34.9	34.0	35.7	36.8	39.0	38.1	40.5	40.3	43.5	41.8	44.8	44.2	46.3	45.4	47.9	47.9	50.3	48.5	51.3	51.5	53.5	52.7	56.5	56.2	57.9	56.4	59.5	
to 400	30 to 80	30.6	32.3	31.6	32.4	33.4	35.1	34.3	35.7	37.3	40.0	38.8	40.5	40.6	43.9	42.6	44.9	44.5	46.6	46.0	48.0	48.2	50.9	49.3	51.5	51.8	54.1	53.8	56.9	56.6	58.5	57.4	59.9	
Under 400	22 to 28	32.7	35.2	33.6	35.3	35.8	38.1	36.7	38.9	39.8	42.7	41.2	44.1	43.7	47.6	45.2	48.8	47.9	50.6	49.1	52.2	51.8	54.9	52.5	56.0	55.7	58.5	57.0	61.7	60.8	63.2	61.0	64.9	
to 200	30 to 80	33.1	35.3	34.2	35.3	36.1	38.3	37.1	39.0	40.3	43.7	41.9	44.2	43.9	47.9	46.0	48.9	48.1	50.9	49.7	52.3	52.1	55.5	53.3	56.2	56.0	59.1	58.0	62.0	61.2	63.9	62.0	65.3	

## Replacing Jackshaft Bearings

### SAFETY

- **NEVER SERVICE A MACHINE WITH THE ENGINE RUNNING, SEVERE PERSONAL INJURY COULD OCCUR. TURN ENGINE OFF THEN REMOVE IGNITION KEY AND DISCONNECT POSITIVE BATTERY CABLE TO AVOID STARTING MACHINE ACCIDENTALLY.**
- **CUTTER WHEEL MUST BE DISENGAGED BEFORE TURNING ENGINE ON/OFF AND BEFORE SERVICING A MACHINE. OTHERWISE SEVERE PERSONAL INJURY COULD OCCUR AS WELL AS MACHINE DAMAGE.**
- **ALL MACHINE PARTS MUST COME TO A COMPLETE STOP AND HAVE TIME TO COOL COMPLETELY BEFORE SERVICING A MACHINE OR SEVERE INJURY COULD OCCUR, POSSIBLY SERIOUS BURNS AND/OR DISMEMBERMENT.**
- **DO NOT OPERATE A MACHINE WITHOUT A COMPLETE NUMBER OF TEETH IN THE CUTTER WHEEL PROPERLY INSTALLED. EXCESSIVE MACHINE VIBRATION WILL OCCUR CAUSING PREMATURE BEARING FAILURE AND EQUIPMENT DAMAGE.**
- **PLACE THE CUTTER WHEEL ON THE GROUND WHEN PERFORMING SERVICE ON A MACHINE.**

In all Carlton® model Stump Grinders, you will find link belt bearings that are made to be purged with grease. It is necessary to purge these bearings everyday till clean grease is seen. **CAUTION** should be taken not to allow grease to build up inside the belt guards.

- Remove the V-belt guard cover.
- Remove engine belts and jackshaft pulley. (See Servicing Belt section to remove engine belts.) To remove the jackshaft pulley, remove the bolts from the bushing and use them to screw into the empty threaded holes to push the bushing out of the pulley. Tighten each screw just a little and go on to the next screw keep tightening a little at a time until the bushing and pulley are separated.



AFTER REMOVING BOLTS, SCREW BOLTS INTO THE THREADED HOLES TO PUSH THE BUSHING OUT OF THE PULLEY

### Replacing Jackshaft Bearings

- Remove Poly Chain® belt guard cover and bottom cover.
- Remove Poly Chain® sprocket by removing the bolts inside the sprocket and tapered bushing. Then screw one bolt into third hole to push sprocket off tapered bushing to remove.
- You may cut the jackshaft between the bearings and the Poly Chain® guard.
- Remove old bearings and shaft and replace with new bearings and shaft. Be sure to turn jackshaft with the longest keyway pocket toward the Poly Chain® belt side of the boom and make sure that the locking collars on the bearings are facing inward. Bolt new bearings and jackshaft back into place. Just snug bolts down, do not tighten all the way down, you will need to move them later to adjust belt tension.

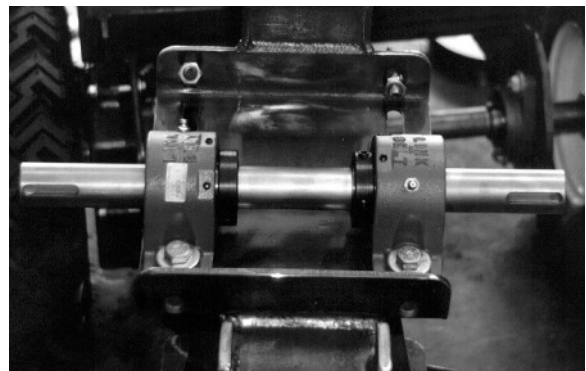
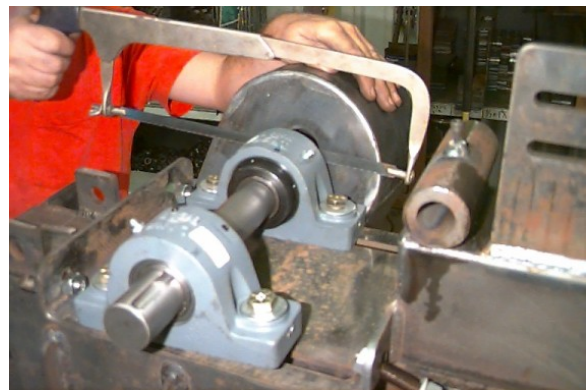

## Replacing Jackshaft Bearings

NOTE: To make shaft installation easier, place shaft in a freezer for approximately one hour or overnight if possible. This will shrink the shaft and make installation into the new bearings much easier.

- Place Poly Chain® sprocket and tapered bushing back onto jackshaft and tighten bolts. Replace Poly Chain® belt. **Alignment is very important, use a straight edge from the jackshaft sprocket down to the cutter wheel sprocket to line up sprockets.**



- After replacing the jackshaft pulley and bushing, use a straight edge and align the jackshaft pulley with the engine pulley. Tighten the three bushing bolts down. As you tighten the bushing bolts, make sure that the pulleys stay aligned.



- There are two setscrews in each bearing. Tighten one of them down, remove one, and punch a start point in the shaft to drill a 5/16" diameter hole just deep enough for the screw to enter the shaft. Do this for all four setscrews. This will help prevent shaft from spinning inside of bearing. When replacing setscrews in bearings, use LocTite® 242 to prevent screws from loosening up.



### Replacing Jackshaft Bearings

NOTE: Refer to **SERVICING BELTS** section for proper installation and tensioning of all belts.

- Replace V-belt guard cover and tighten bolts.



- Replace Poly Chain® belt guard cover and end guard cover and tighten bolts.

**DO NOT RUN MACHINE WITHOUT  
ALL GUARDS IN PLACE AND  
SECURED PROPERLY.**





## Replacing Cutter Wheel Bearings

### SAFETY

- **NEVER SERVICE A MACHINE WITH THE ENGINE RUNNING, SEVERE PERSONAL INJURY COULD OCCUR. TURN ENGINE OFF THEN REMOVE IGNITION KEY AND DISCONNECT POSITIVE BATTERY CABLE TO AVOID STARTING MACHINE ACCIDENTALLY.**
- **CUTTER WHEEL MUST BE DISENGAGED BEFORE TURNING ENGINE ON/OFF AND BEFORE SERVICING A MACHINE. OTHERWISE SEVERE PERSONAL INJURY COULD OCCUR AS WELL AS MACHINE DAMAGE.**
- **ALL MACHINE PARTS MUST COME TO A COMPLETE STOP AND HAVE TIME TO COOL COMPLETELY BEFORE SERVICING A MACHINE OR SEVERE INJURY COULD OCCUR, POSSIBLY SERIOUS BURNS AND/OR DISMEMBERMENT.**
- **DO NOT OPERATE A MACHINE WITHOUT A COMPLETE NUMBER OF TEETH IN THE CUTTER WHEEL PROPERLY INSTALLED. EXCESSIVE MACHINE VIBRATION WILL OCCUR CAUSING PREMATURE BEARING FAILURE AND EQUIPMENT DAMAGE.**
- **PLACE THE CUTTER WHEEL ON THE GROUND WHEN PERFORMING SERVICE ON A MACHINE.**

In all Carlton® model Stump Grinders, you will find link belt bearings that are made to be purged. It is necessary to purge these bearing everyday until clean grease is seen. **CAUTION should be taken not to allow grease to build up inside the belt guards.**

- Remove the Poly Chain® guard cover and bottom cover.



- Loosen Poly Chain® belt by moving jackshaft bearings. **MARK THEM SO THAT YOU KNOW HOW THEY ARE POSITIONED ON THE JACKSHAFT PLATE.** Loosen the four bolts that hold the jackshaft bearings down, do not remove the bolts.



### Replacing Cutter Wheel Bearings

- Loosen jam bolts in the back of the jackshaft bearings and move bearings back to remove the Poly Chain® belt. You may need to unbolt V-belt guard and lift jackshaft end up to remove belt.
- Remove the four bolts on the cutter wheel bearings. Cutter wheel will be free from machine at this point. With the Poly Chain® belt removed, you can start the machine and raise the boom up.
- Cut the cutter wheel shaft on one side of the cutter wheel so that you can get the cutter wheel off of the shaft.
- Remove Poly Chain® sprocket by removing the bolts inside the sprocket and tapered bushing. Then screw one bolt into third hole to push sprocket off tapered bushing to remove.

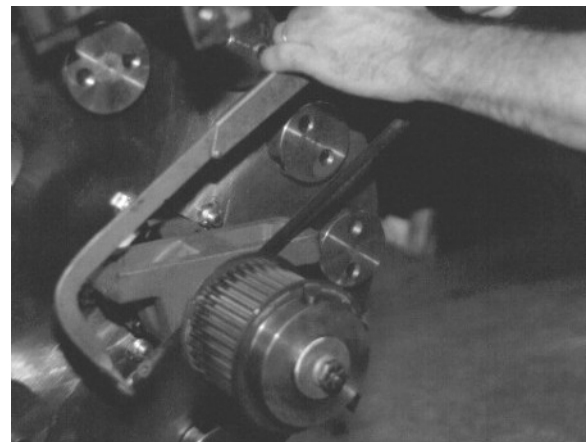
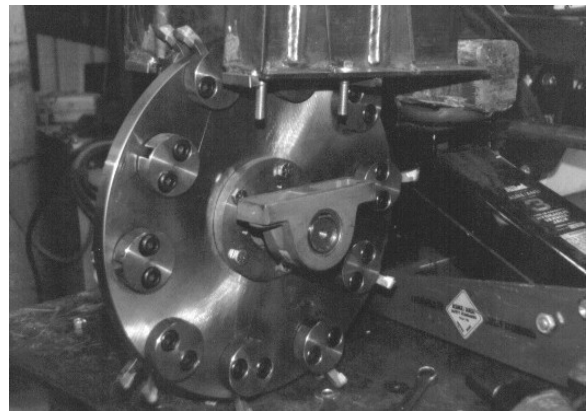

### Replacing Cutter Wheel Bearings

- Take out the three bolts that hold the bushing to the cutter wheel and place them in the empty threaded holes on the bushing and tighten slowly. This will push the bushing out of the cutter wheel. Remove bushing and cutter wheel.
- Place cutter wheel, bushing and bearings back on new shaft. Place back up under machine and lower boom box on to bearings.

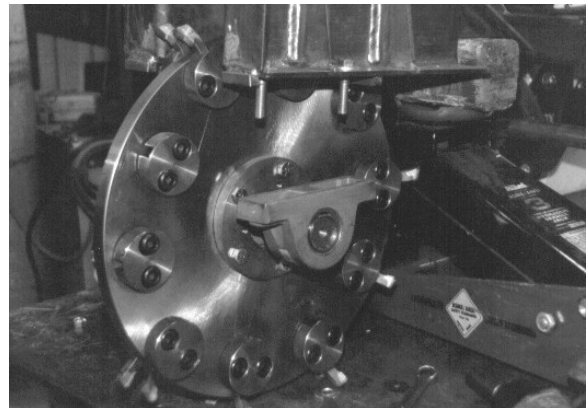
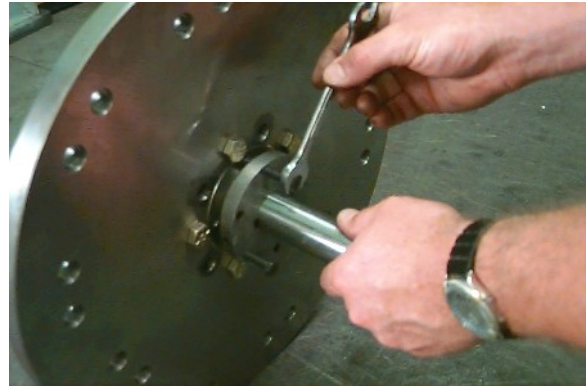

NOTE: To make shaft installation easier, place shaft in a freezer for approximately one hour or overnight if possible. This will shrink the shaft and make installation into the new bearings much easier.

- Bolt bearings and cutter wheel back to boom box and tighten bolts down.



### Replacing Cutter Wheel Bearings

- Place Poly Chain® sprocket and tapered bushing back onto cutter wheel shaft and tighten bolts. Replace Poly Chain® belt. **Alignment is very important, use a straight edge from the jackshaft sprocket down to the cutter wheel sprocket to line up sprockets.**



- There are two setscrews in each bearing. Tighten one of them down, remove one, and punch a start point in the shaft to drill a 5/16" diameter hole just deep enough for the screw to enter the shaft. Do this for all four setscrews. This will help prevent shaft from spinning and walking inside of bearing. When putting setscrew in bearing, use LocTite® 242 to prevent screw from loosening up.

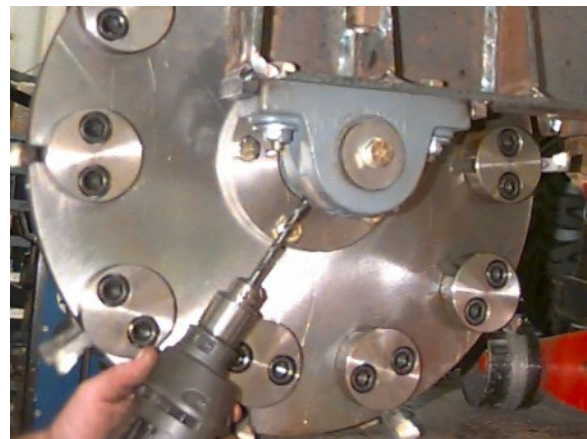

NOTE: Refer to **SERVICING BELTS** section for proper installation and tensioning of all belts.

- Replace Poly Chain® guard cover and bottom guard. Tighten bolts.

**DO NOT RUN MACHINE WITHOUT ALL GUARDS IN PLACE AND SECURED PROPERLY.**



**SAFETY**

- **NEVER SERVICE A MACHINE WITH THE ENGINE RUNNING, SEVERE PERSONAL INJURY COULD OCCUR. TURN ENGINE OFF THEN REMOVE IGNITION KEY AND DISCONNECT POSITIVE BATTERY CABLE TO AVOID STARTING MACHINE ACCIDENTALLY.**
- **CUTTER WHEEL MUST BE DISENGAGED BEFORE TURNING ENGINE ON/OFF AND BEFORE SERVICING A MACHINE. OTHERWISE SEVERE PERSONAL INJURY COULD OCCUR AS WELL AS MACHINE DAMAGE.**
- **ALL MACHINE PARTS MUST COME TO A COMPLETE STOP AND HAVE TIME TO COOL COMPLETELY BEFORE SERVICING A MACHINE OR SEVERE INJURY COULD OCCUR, POSSIBLY SERIOUS BURNS AND/OR DISMEMBERMENT.**
- **DO NOT OPERATE A MACHINE WITHOUT A COMPLETE NUMBER OF TEETH IN THE CUTTER WHEEL PROPERLY INSTALLED. EXCESSIVE MACHINE VIBRATION WILL OCCUR CAUSING PREMATURE BEARING FAILURE AND EQUIPMENT DAMAGE.**
- **PLACE THE CUTTER WHEEL ON THE GROUND WHEN PERFORMING SERVICE ON A MACHINE.**

- Grease steering pivots at least every 2-3 months. Use Texaco® Starplex II grease. **DO NOT OVER GREASE.**



The steering axle is equipped with industrial hubs. To service, jack up the front end, remove cap. Loosen nut and slide wheel off. You are then able to inspect back seals, bearings and races. If necessary you may re-grease and install back on spindle. Tighten axle nut till bearing is tight and wheel will hardly turn. Then back off one notch. Do this at least every 6 months. (See Front Axle Assembly for breakdown)

**SAFETY**

- **NEVER SERVICE A MACHINE WITH THE ENGINE RUNNING, SEVERE PERSONAL INJURY COULD OCCUR. TURN ENGINE OFF THEN REMOVE IGNITION KEY AND DISCONNECT POSITIVE BATTERY CABLE TO AVOID STARTING MACHINE ACCIDENTALLY.**
- **CUTTER WHEEL MUST BE DISENGAGED BEFORE TURNING ENGINE ON/OFF AND BEFORE SERVICING A MACHINE. OTHERWISE SEVERE PERSONAL INJURY COULD OCCUR AS WELL AS MACHINE DAMAGE.**
- **ALL MACHINE PARTS MUST COME TO A COMPLETE STOP AND HAVE TIME TO COOL COMPLETELY BEFORE SERVICING A MACHINE OR SEVERE INJURY COULD OCCUR, POSSIBLY SERIOUS BURNS AND/OR DISMEMBERMENT.**
- **PLACE THE CUTTER WHEEL ON THE GROUND WHEN PERFORMING SERVICE ON A MACHINE.**

- Swing the cutter wheel to the right to access the boom pivot grease fitting. Grease boom pivot monthly. **Do not over grease.** There is a Pop-Out Valve above the grease fitting, if the pin pops out enough grease has been applied. Wipe off excess grease. **Excess grease will attract dirt.**

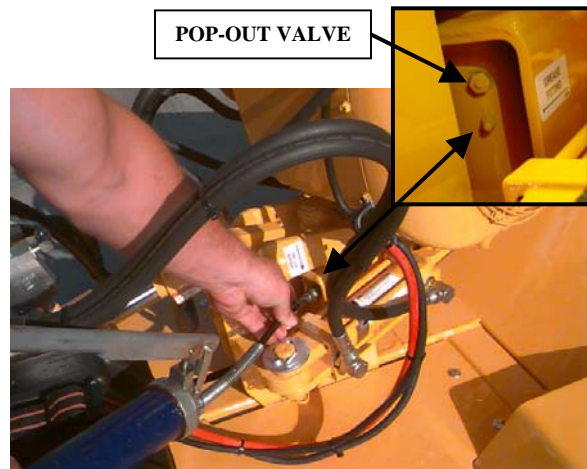

- The boom pivot is equipped with a hardened shaft and Timken® roller bearings. If the boom becomes loose, you will need to apply pressure to the bearings to tighten it. To apply more pressure to the bearings, hold the bottom nut where the cotter pin is. Remove the first nut and tighten the second nut, which will apply pressure to the roller bearings and the boom swing. You can place cutter wheel on ground and put slight pressure on cutter wheel to adjust pivot bearings.



If the main pivot bearings need replacing, you will have to remove the top pin and slide the main pivot out and install the new bearings. **See Upper Pivot Assembly for breakdown.**

- **Boom must be placed in a fixture to hold steady when you remove the pivot pin.**

**SAFETY**

- **NEVER SERVICE A MACHINE WITH THE ENGINE RUNNING, SEVERE PERSONAL INJURY COULD OCCUR. TURN ENGINE OFF THEN REMOVE IGNITION KEY AND DISCONNECT POSITIVE BATTERY CABLE TO AVOID STARTING MACHINE ACCIDENTALLY.**
- **CUTTER WHEEL MUST BE DISENGAGED BEFORE TURNING ENGINE ON/OFF AND BEFORE SERVICING A MACHINE. OTHERWISE SEVERE PERSONAL INJURY COULD OCCUR AS WELL AS MACHINE DAMAGE.**
- **ALL MACHINE PARTS MUST COME TO A COMPLETE STOP AND HAVE TIME TO COOL COMPLETELY BEFORE SERVICING A MACHINE OR SEVERE INJURY COULD OCCUR, POSSIBLY SERIOUS BURNS AND/OR DISMEMBERMENT.**
- **DO NOT OPERATE A MACHINE WITHOUT A COMPLETE NUMBER OF TEETH IN THE CUTTER WHEEL PROPERLY INSTALLED. EXCESSIVE MACHINE VIBRATION WILL OCCUR CAUSING PREMATURE BEARING FAILURE AND EQUIPMENT DAMAGE.**
- **PLACE THE CUTTER WHEEL ON THE GROUND WHEN PERFORMING SERVICE ON A MACHINE.**

- There are twenty (20) teeth to a complete set on the model SP4012. Two (2) straight teeth, nine (9) left 45° teeth and nine (9) right 45° teeth.



- A locking pin is provided to hold cutter wheel in position during tooth removal and re-installation. Locking pin will only lock on outer teeth.  
**NEVER PLACE HAND ON CUTTER WHEEL TO HOLD IN PLACE WHILE CHANGING TEETH. BE SURE TO REMOVE PIN BEFORE OPERATING.**



- A Tooth Setting Gauge (P/N 0450111) is provided with each machine for proper tooth installation. Line all teeth up with the inside edge of the groove in the gauge. Set **ALL** teeth to this edge with gauge against pocket, not against cutter wheel.  
**See Cutter Wheel Assembly for breakdown.**



**TOOTH ARRANGEMENT**

- Inspect pockets, teeth and bolts for damage and replace as required.
- When replacing pockets, always replace new pockets across from each other in order to prevent vibration.
- Replacement teeth must be carbide tipped and have like design as provided with the machine.
- Use anti-seize on threads to prevent bolts from “freezing up” in cutter wheel.
- When replacing complete set of teeth, be sure to duplicate original factory tooth arrangement.
- Torque bolts to 150 ft/lbs.

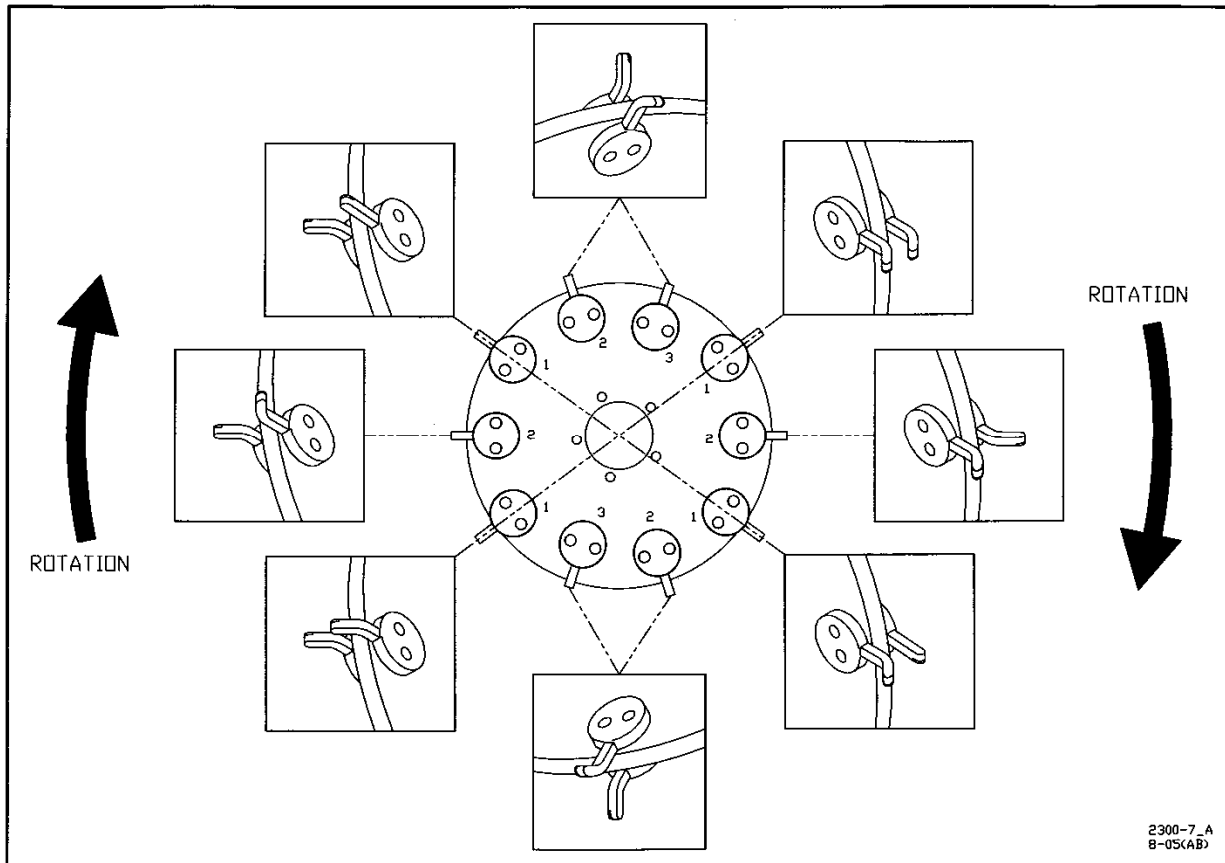

opposing outside pockets carry like arrangements of teeth to cancel vibration

- Straight teeth are mounted in **TWO OPPOSING OUTSIDE POCKETS.** A straight tooth must have a 45° tooth accompanying it in the same pocket set.
- The opposite pocket sets should have this same combination of straight and 45° teeth, except with positions reversed. Mounting these teeth opposite each other on the cutter wheel cancels damaging vibration.
- **Two Remaining Outside Pockets** must have 45° teeth overlapping centerline of wheel to make plunge cuts possible. Mount two left 45° teeth opposite two right 45° teeth.
- Inside pockets require 45° teeth mounted away from the wheel.



### OPTIONAL:

#### Sandvik® Dura Disk II Cutter Wheel

- If the machine is supplied with the optional Dura Disk II cutter wheel, there are thirty-two (36) teeth to a complete set. There are eight (12) Short Plow Bolt Bits (Carlton part #0450131) and twenty-four (24) Plow Bolt Bits (Carlton part #0450130).
- **DO NOT OPERATE A MACHINE WITHOUT A COMPLETE NUMBER OF TEETH IN THE CUTTER WHEEL PROPERLY INSTALLED. EXCESSIVE MACHINE VIBRATION WILL OCCUR CAUSING PREMATURE BEARING FAILURE AND EQUIPMENT DAMAGE.**
- A locking pin is provided to hold cutter wheel in position during tooth removal and re-installation.
- The locking pin will only lock in the deep slots of the outer teeth. Line the slot up with the locking pin slot and insert the pin to lock position. The pin will need to be removed and reinserted as wheel is rotated to change remaining teeth. (Some early machines will only lock on an outside 20° tooth.)
- **NEVER PLACE YOUR HAND ON THE CUTTER WHEEL TO HOLD IT IN PLACE WHILE CHANGING TEETH.**
- **BE SURE TO REMOVE THE PIN BEFORE OPERATING THE STUMP CUTTER.**
- The teeth do not require a setting gauge. The only requirement is to be installed in the proper direction and tightened to the proper torque as discussed in the next section.
- **When replacing a cutter wheel tooth, replace the tooth and nut as a set and use anti-seize on the threads.**



**TOOTH ARRANGEMENT**

- Inspect pockets, teeth and bolts for damage and replace as required.
- When replacing a cutter wheel tooth, replace the tooth and nut as a set and use anti-seize on the threads.
- When replacing teeth and pockets, also replace the teeth and pockets across from each other diagonally in order to maintain wheel balance and prevent vibration.
- All teeth and pockets are of a specific design and must be replaced with original manufacturer’s replacement parts. Replacement teeth must be carbide tipped.
- When replacing complete set of teeth, be sure to duplicate original factory tooth arrangement. SEE DIAGRAM BELOW.
- The seating surfaces of the tooth and pocket are formed, but make sure the tooth is inserted with the carbide facing the direction of rotation.
- The pictured view is the engraved side of the wheel. The wheel is engraved with outside pocket numbers, outside pocket angle/direction (20 R or 20 L), and wheel rotation. (The engraved side of wheel is marked left side of wheel; this is for manufacturing purposes only. It does not refer to the left side of the machine as described in the General Information section.)
- Outside pocket teeth are Short Plow Bolt Bits. These pockets are angled and welded in place. You can switch teeth from one outside pocket to a pocket that is the opposite direction to prolong tooth life, such as switching a tooth from a 20 R with a tooth from a 20 L pocket. The cutting edge is the corner and this will turn the opposite corner out for use.
- These teeth are tightened with Stover Lock Nuts. Torque on Stover locking nuts is not to exceed 270 ft/lbs.
- All teeth on cutter wheel sides are Plow Bolt Bits. When changing these teeth you must remove both teeth in the same pocket, one on each side of the wheel. When the nuts are torqued, the pocket is jammed and the teeth can only be removed this way.
- These teeth are also tightened with Stover Lock Nuts. Torque on Stover locking nuts is not to exceed 270 ft/lbs.
- The pocket will receive wear when cutting and can be switched from one side of the cutter wheel to the other to prolong life. Remember the teeth must be replaced in the original position on each side of the wheel.

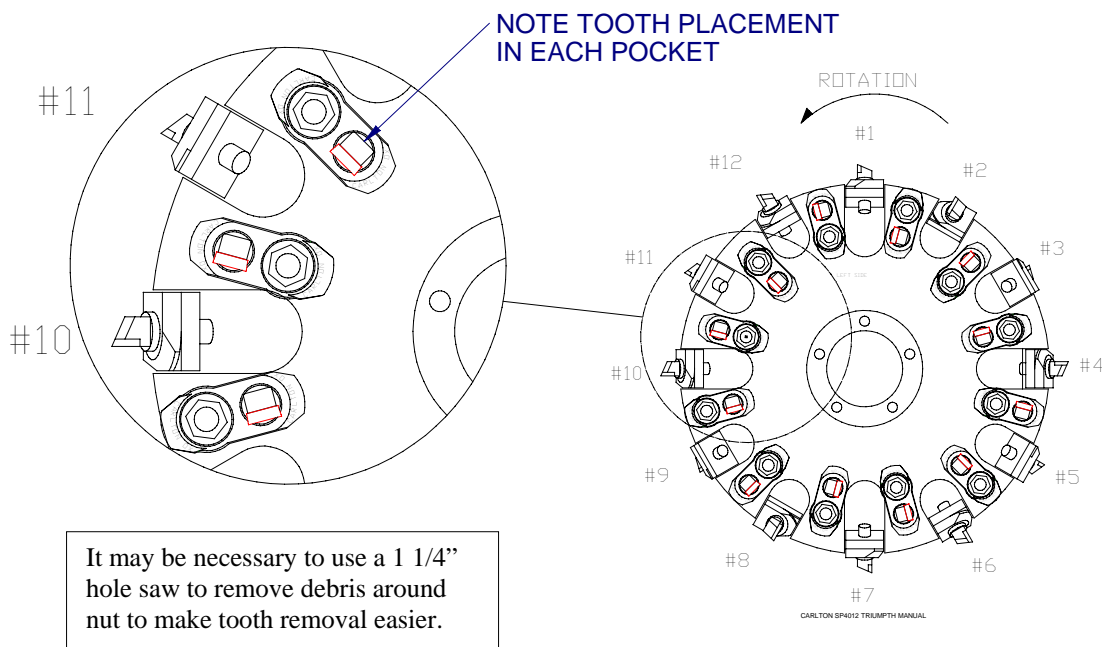

**TOOTH SHARPENING**

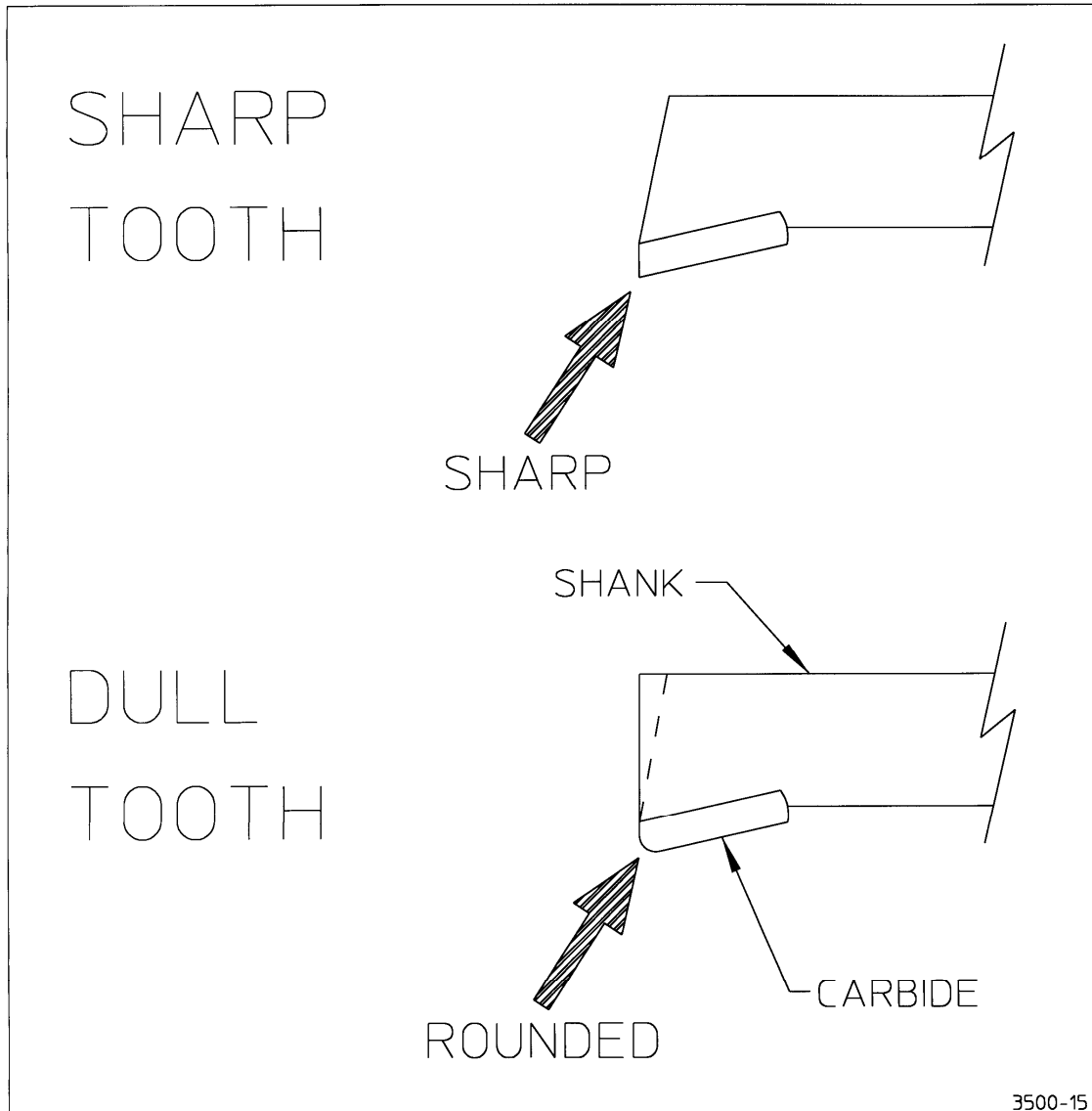

Begin by chamfering shank back past edge of carbide. You do this because if it is not back far enough the shank will hit the stump and not the carbide, thus causing a lot of vibration. Once the shank is angled far enough back, then begin sharpening carbide.

- **Cut shank with a standard rock and cut carbide with a silicone carbide or diamond rock.**  
**CAUTION: GRINDING CARBIDE CAN BE A HEALTH HAZARD.** Use facemask to prevent breathing in harmful material while grinding.

## **SAFETY**

- **NEVER SERVICE A MACHINE WITH THE ENGINE RUNNING, SEVERE PERSONAL INJURY COULD OCCUR. TURN ENGINE OFF THEN REMOVE IGNITION KEY AND DISCONNECT POSITIVE BATTERY CABLE TO AVOID STARTING MACHINE ACCIDENTALLY.**
- **CUTTER WHEEL MUST BE DISENGAGED BEFORE TURNING ENGINE ON/OFF AND BEFORE SERVICING A MACHINE. OTHERWISE SEVERE PERSONAL INJURY COULD OCCUR AS WELL AS MACHINE DAMAGE.**
- **ALL MACHINE PARTS MUST COME TO A COMPLETE STOP AND HAVE TIME TO COOL COMPLETELY BEFORE SERVICING A MACHINE OR SEVERE INJURY COULD OCCUR, POSSIBLY SERIOUS BURNS AND/OR DISMEMBERMENT.**
- **PLACE THE CUTTER WHEEL ON THE GROUND WHEN PERFORMING SERVICE ON A MACHINE.**
- **RELEASE HYDRAULIC PRESSURE BEFORE PERFORMING ANY SERVICE TO HYDRAULIC LINES OR OTHER COMPONENTS.**
- **FLUID UNDER PRESSURE CAN PENETRATE THE SKIN AND CAUSE SEVERE INJURY. SEEK IMMEDIATE MEDICAL ATTENTION IF SKIN IS PENETRATED. CHECK HOSES AND FITTINGS USING A BOARD OR CARDBOARD; DO NOT USE HAND OR FINGER. ALWAYS WEAR EYE PROTECTION.**

## **HYDRAULIC OIL & FILTER**

- Check hydraulic oil level daily. This Carlton stump grinder is equipped with a gauge that shows the level of oil and the temperature of the oil. When filling the tank with oil, the window of the gauge will also fill with oil, as the level gets higher in the tank. Never fill the oil tank above the **BLACK** line at the top of the gauge. Do not run the machine with the oil level below the **RED** line at the bottom of the gauge.
- The machine is equipped with Citgo AW32 hydraulic oil at the time of manufacture. Use the same or equivalent.



- For a new machine, change the hydraulic oil filter when the stump grinder has been operating for 10 hours. Replace with the same type of in-tank filter element supplied originally, available through Carlton or Carlton dealers. From this point on, change the filter every 200 hours of operation.
- Change hydraulic oil every 500 hours of operation or at least once a year depending on use. Flush the hydraulic tank when changing the hydraulic oil. Replace oil if it has a burnt odor or if it is contaminated. Replace oil if the stump grinder has been stored for a long period of time (all winter).
- Drain the hydraulic tank using the drain plug located on the bottom of the tank. Dispose of used oil according to state regulations.



### HYDRAULIC OIL COOLER

(only on remote control machines)

- There is a hydraulic oil cooler on all remote control machines to keep the hydraulic oil from over heating. There is a temp sensor in the bottom of the oil cooler and if the oil temperature rises to 140° or higher the fan comes on to cool the oil. The fan may go on and off as the temperature of the oil changes depending on the environment and the operation of the grinder.
- Keep the fins clean. Use a garden hose and a mild detergent. Do not use a power washer as it may cause the fins to bend. Do not use an industrial strength detergent that may cause the metal to deteriorate.
- Inspect all connections and hoses for leaks and wear. Replace if necessary. Use extra care when inspecting hoses with fluid under pressure. **DO NOT** use your finger or hand to inspect for leaks, use a board or cardboard. Follow all safety procedures at the beginning of the Servicing Hydraulics section.



### REPLACING HYDRAULIC PUMP

- Engine must be shut off.
- Disconnect hydraulic lines from pump and cap them.
- Remove bolts holding mounting plate to machine (located at 6 & 12 o'clock position)
- Remove plate/pump assembly by pulling assembly straight out. Drive coupling will separate and make removal possible. Make sure to set aside fiber spacer for later re-installation.
- Remove drive coupling half from pump shaft by loosening Allen screw. It may be necessary to pry apart coupling by inserting screwdriver into coupling split and relieving pressure on pump shaft. Set aside key-way for later re-installation.
- Remove pump from backing plate by removing mounting bolts.
- To install new pump, reverse this process. Making sure to replace fiber spacer in coupling.
- Recheck oil supply in reservoir.

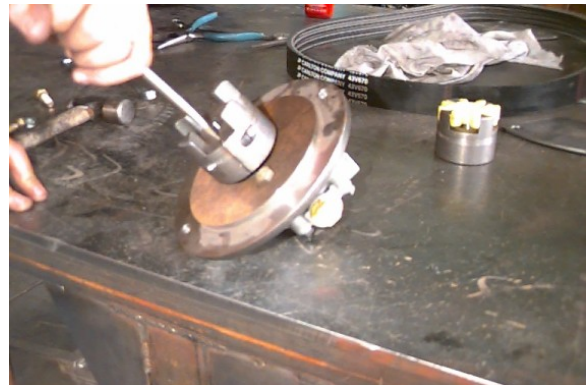
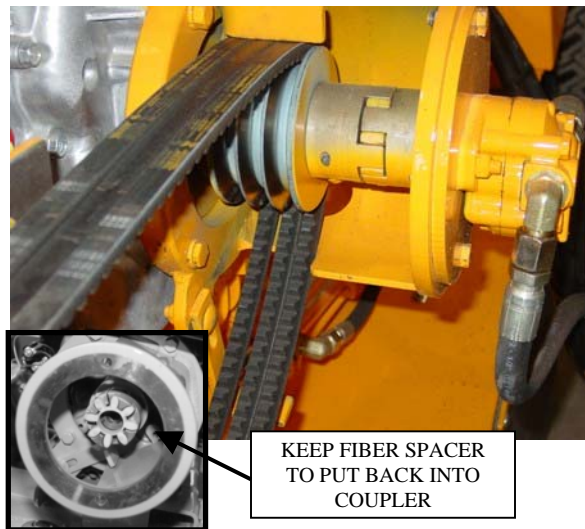

### REPLACING HARDENED BUSHINGS

- Hardened bushings have been incorporated into the machine to protect the frame from wear and damage.
- Should a bushing need replacing, disconnect the rod end from the frame and swing cylinder out of the way.
- Position the new bushing directly above the old bushing and gently tap new bushing down into position thus removing the old bushing.
- Swing cylinder back into position. Use new pin assemblies to re-install rod end to frame.





STANDARD WIRING DIAGRAM

SP4012 STANDARD MACHINE WIRING DIAGRAM (VANGUARD)

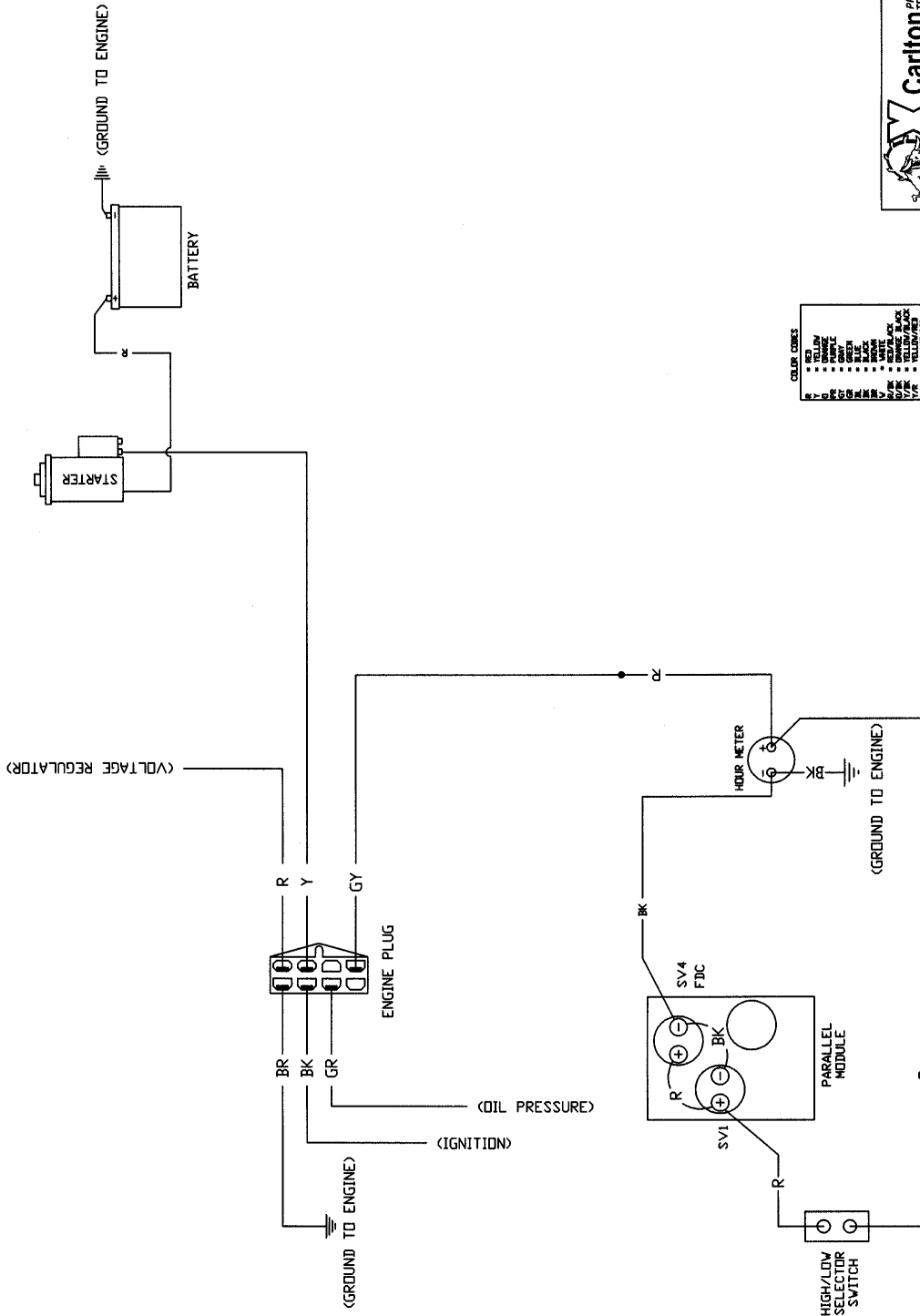

COLOR CODES

RED	RED/BLACK
YELLOW	YELLOW/BLACK
PINK	PINK/BLACK
ORANGE	ORANGE/BLACK
GREEN	GREEN/BLACK
BLUE	BLUE/BLACK
BROWN	BROWN/BLACK
BLACK	BLACK/BLACK
WHITE	WHITE/BLACK
GRAY	GRAY/BLACK
RED	RED/WHITE
YELLOW	YELLOW/WHITE
PINK	PINK/WHITE
ORANGE	ORANGE/WHITE
GREEN	GREEN/WHITE
BLUE	BLUE/WHITE
BROWN	BROWN/WHITE
BLACK	BLACK/WHITE
WHITE	WHITE/WHITE
GRAY	GRAY/WHITE
RED	RED/RED
YELLOW	YELLOW/YELLOW
PINK	PINK/PINK
ORANGE	ORANGE/ORANGE
GREEN	GREEN/GREEN
BLUE	BLUE/BLUE
BROWN	BROWN/BROWN
BLACK	BLACK/BLACK
WHITE	WHITE/WHITE
GRAY	GRAY/GRAY

**Carlton**  
PROFESSIONAL  
TREE EQUIPMENT

CHECKED BY: \_\_\_\_\_  
SP4012BS-10 CURRENT 6AB/10/19/02





REMOTE WIRING DIAGRAM

SP4012 MACHINE REMOTE WIRING DIAGRAM (VANGUARD)  
W/16-PIN CONNECTOR, DUAL DRIVE MOTORS  
& OIL COOLER

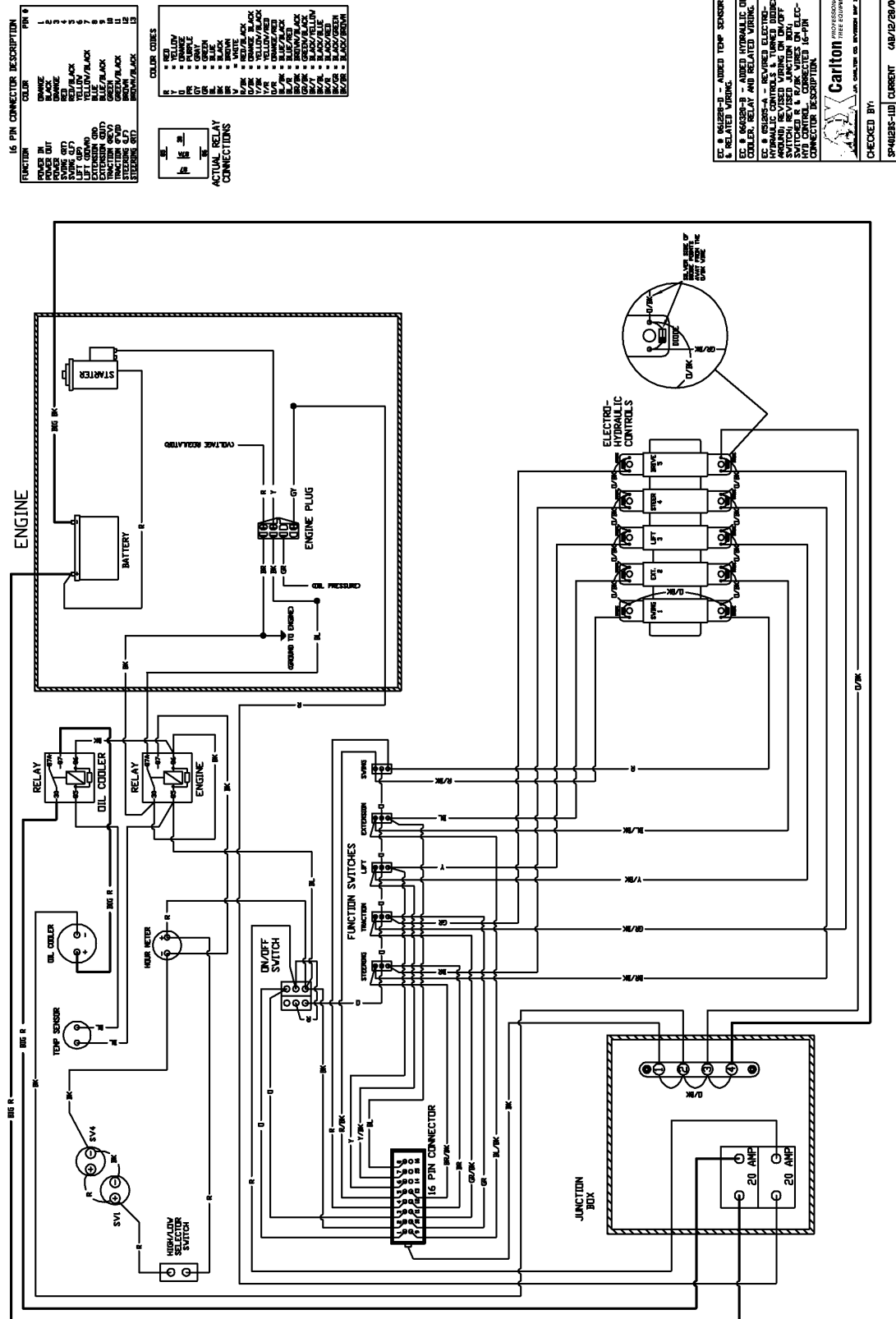

REMOTE BOX WIRING DIAGRAM

SP4012 REMOTE CONTROL WIRING DIAGRAM  
W/16-PIN CONNECTOR

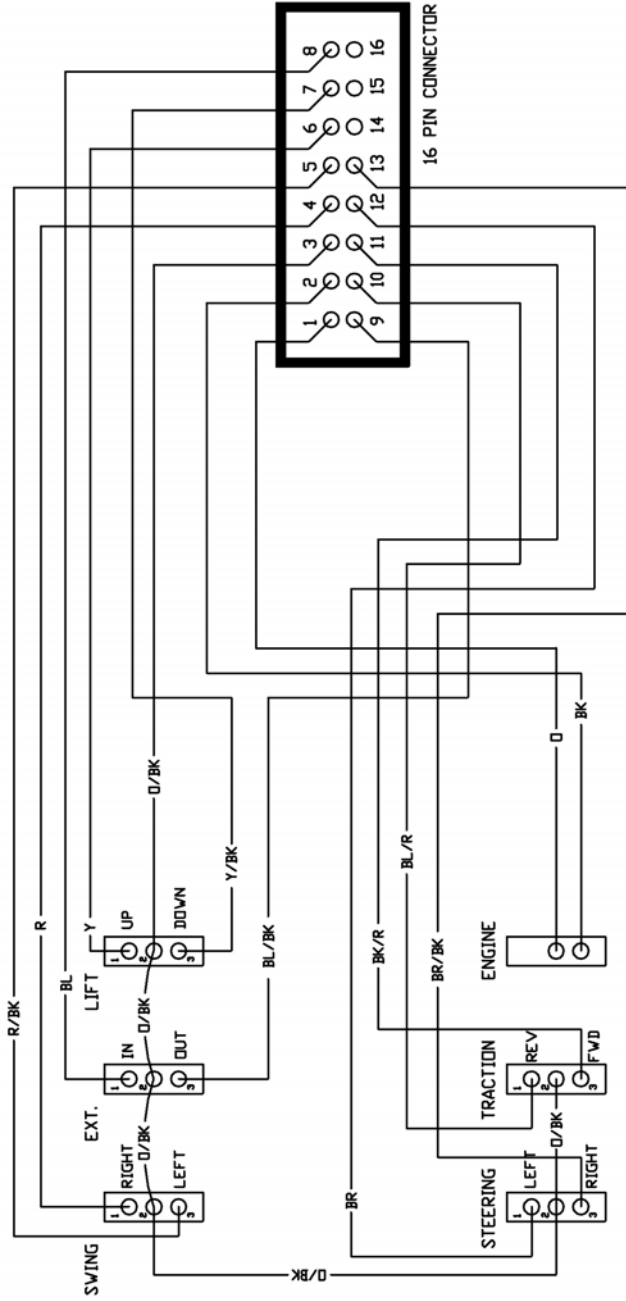

COLOR CODES

R	= RED
Y	= YELLOW
O	= ORANGE
PR	= PURPLE
GY	= GRAY
GR	= GREEN
BL	= BLUE
BK	= BLACK
BR	= BROWN
W	= WHITE
R/BK	= RED/BLACK
O/BK	= ORANGE/BLACK
Y/BK	= YELLOW/BLACK
Y/R	= YELLOW/RED
O/R	= ORANGE/RED
BL/BK	= BLUE/BLACK
BL/R	= BLUE/RED
BR/BK	= BROWN/BLACK
BK/Y	= BLACK/YELLOW
BK/BL	= BLACK/BLUE
BK/R	= BLACK/RED

16-PIN CONNECTOR FUNCTIONS

FUNCTION	COLOR	PIN #
POWER IN	ORANGE	1
POWER OUT	BLACK	2
SWING (D)	ORANGE/BLACK	3
SWING (L)	RED/BLACK	4
SWING (R)	YELLOW	5
LIFT (UP)	YELLOW/BLACK	6
LIFT (DOWN)	BLUE	7
EXTENSION (IN)	BLUE/BLACK	8
EXTENSION (OUT)	BLUE/RED	9
TRACTION (REVERSE)	BLACK/RED	10
TRACTION (FORWARD)	BROWN	11
STEERING (LEFT)	BLACK/BLUE	12
STEERING (RIGHT)	BROWN/BLACK	13

EC # 060918-A - CORRECTED 16-PIN CONNECTOR DESCRIPTIONS.	<p><b>Carlton</b> PROFESSIONAL TREE EQUIPMENT J.P. CARLTON CO. DIVISION IMP INC</p>
EC # 040402 - WAS 2500-12B (MACHINE WAS RENAMED)	
CHECKED BY:	
SP4012-12A	CURRENT (AB/9/18/06)

RADIO WIRING DIAGRAM

SP4012 MACHINE REMOTE WIRING DIAGRAM (VANGUARD)  
W/16-PIN CONNECTOR, R-160 CONNECTOR,  
DUAL DRIVE MOTORS & OIL COOLER

**R160 CONNECTOR DIAGRAM**

PIN#	COLOR	FUNCTION
A1	BLACK	RELAY
A2	BLACK/WHITE	RELAY
A3	BLACK/WHITE/RED	RELAY
A4	RED	RELAY
A5	ORANGE/GREEN	RELAY
A6	WHITE/BLACK	RELAY
A7	WHITE/BLACK	RELAY
A8	BLACK/RED	RELAY
A9	BLACK/RED	RELAY
A10	BLACK/RED	RELAY
A11	BLACK/RED	RELAY
A12	BLACK/RED	RELAY
A13	BLACK/RED	RELAY
A14	BLACK/RED	RELAY
A15	BLACK/RED	RELAY
A16	BLACK/RED	RELAY
A17	BLACK/RED	RELAY
A18	BLACK/RED	RELAY
A19	BLACK/RED	RELAY
A20	BLACK/RED	RELAY
A21	BLACK/RED	RELAY
A22	BLACK/RED	RELAY
A23	BLACK/RED	RELAY
A24	BLACK/RED	RELAY
A25	BLACK/RED	RELAY
A26	BLACK/RED	RELAY
A27	BLACK/RED	RELAY
A28	BLACK/RED	RELAY
A29	BLACK/RED	RELAY
A30	BLACK/RED	RELAY
A31	BLACK/RED	RELAY
A32	BLACK/RED	RELAY
A33	BLACK/RED	RELAY
A34	BLACK/RED	RELAY
A35	BLACK/RED	RELAY
A36	BLACK/RED	RELAY
A37	BLACK/RED	RELAY
A38	BLACK/RED	RELAY
A39	BLACK/RED	RELAY
A40	BLACK/RED	RELAY
A41	BLACK/RED	RELAY
A42	BLACK/RED	RELAY
A43	BLACK/RED	RELAY
A44	BLACK/RED	RELAY
A45	BLACK/RED	RELAY
A46	BLACK/RED	RELAY
A47	BLACK/RED	RELAY
A48	BLACK/RED	RELAY
A49	BLACK/RED	RELAY
A50	BLACK/RED	RELAY
A51	BLACK/RED	RELAY
A52	BLACK/RED	RELAY
A53	BLACK/RED	RELAY
A54	BLACK/RED	RELAY
A55	BLACK/RED	RELAY
A56	BLACK/RED	RELAY
A57	BLACK/RED	RELAY
A58	BLACK/RED	RELAY
A59	BLACK/RED	RELAY
A60	BLACK/RED	RELAY
A61	BLACK/RED	RELAY
A62	BLACK/RED	RELAY
A63	BLACK/RED	RELAY
A64	BLACK/RED	RELAY
A65	BLACK/RED	RELAY
A66	BLACK/RED	RELAY
A67	BLACK/RED	RELAY
A68	BLACK/RED	RELAY
A69	BLACK/RED	RELAY
A70	BLACK/RED	RELAY
A71	BLACK/RED	RELAY
A72	BLACK/RED	RELAY
A73	BLACK/RED	RELAY
A74	BLACK/RED	RELAY
A75	BLACK/RED	RELAY
A76	BLACK/RED	RELAY
A77	BLACK/RED	RELAY
A78	BLACK/RED	RELAY
A79	BLACK/RED	RELAY
A80	BLACK/RED	RELAY
A81	BLACK/RED	RELAY
A82	BLACK/RED	RELAY
A83	BLACK/RED	RELAY
A84	BLACK/RED	RELAY
A85	BLACK/RED	RELAY
A86	BLACK/RED	RELAY
A87	BLACK/RED	RELAY
A88	BLACK/RED	RELAY
A89	BLACK/RED	RELAY
A90	BLACK/RED	RELAY
A91	BLACK/RED	RELAY
A92	BLACK/RED	RELAY
A93	BLACK/RED	RELAY
A94	BLACK/RED	RELAY
A95	BLACK/RED	RELAY
A96	BLACK/RED	RELAY
A97	BLACK/RED	RELAY
A98	BLACK/RED	RELAY
A99	BLACK/RED	RELAY
A100	BLACK/RED	RELAY

**16 PIN CONNECTOR DESCRIPTION**

FUNCTION	COLOR	PIN #
POWER IN	BLACK	1
POWER OUT	BLACK	2
STARTER	BLACK	3
SWING SET	RED	4
SWING SET	YELLOW/BLACK	5
LEFT DRIVE	YELLOW/BLACK	6
LEFT DRIVE	BLACK/BLACK	7
EXTENSION OIL	BLACK/BLACK	8
EXTENSION OIL	GREEN/BLACK	9
STEERING SET	BROWN/BLACK	10
STEERING SET	BROWN/BLACK	11
STEERING SET	BROWN/BLACK	12

**COLOR CODES**

- RED
- YELLOW
- PURPLE
- ORANGE
- GREEN
- BLACK
- BROWN
- RED/BLACK
- YELLOW/BLACK
- YELLOW/RED
- BLACK/BLACK
- GREEN/BLACK
- ORANGE/BLACK
- WHITE/BLACK
- BLACK/WHITE
- BLACK/RED
- BLACK/BROWN

**ACTUAL RELAY CONNECTIONS**

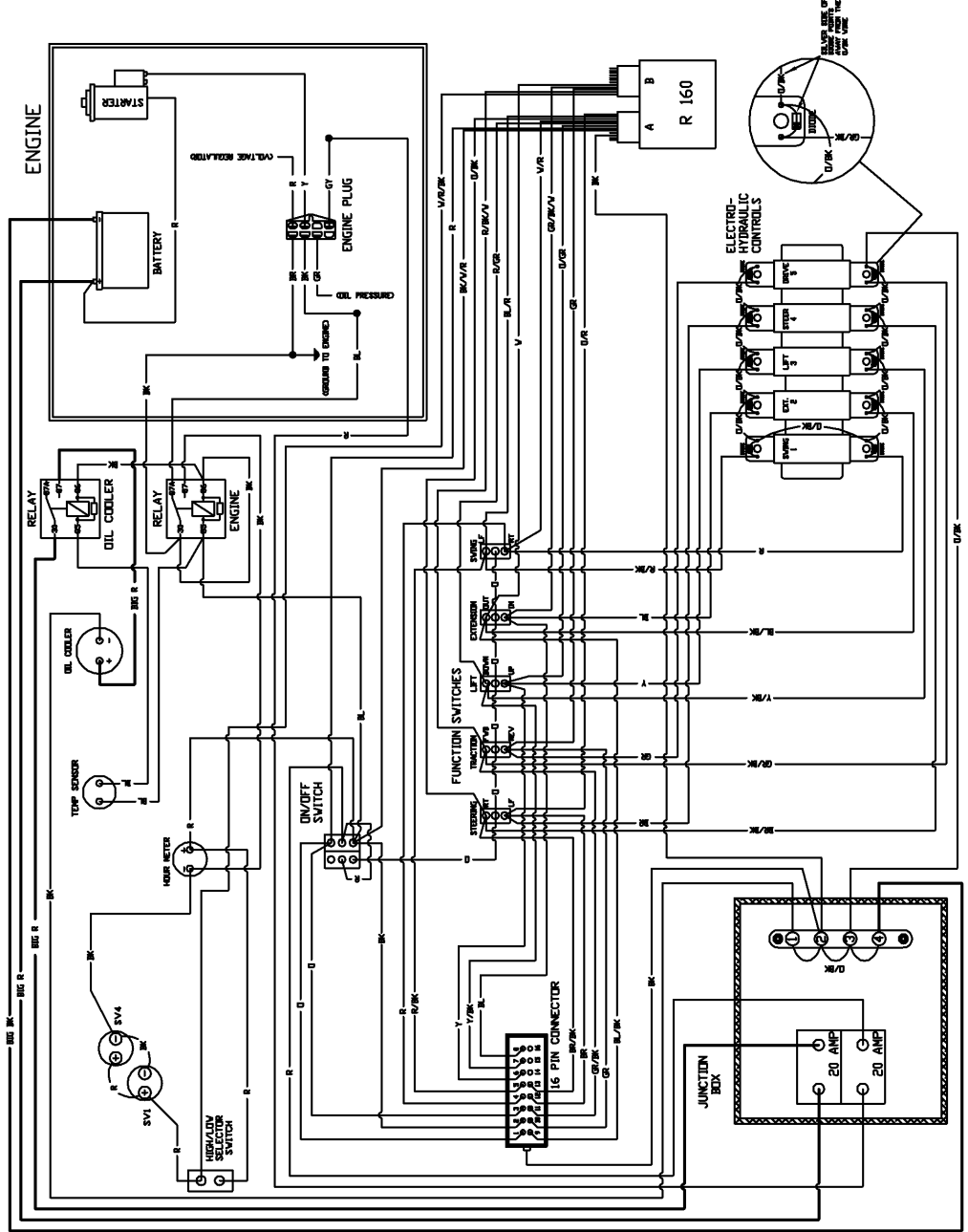

ES & OILERS - AIRBID TEMP SENSOR & RELATED WIRING.  
ES & OILERS-C - AIRBID DMEK CONNECTOR AND WIRING.  
ES & OILERS-B - AIRBID HYDRAULIC OIL COOLER, RELAY AND RELATED WIRING.  
ES & OILERS-A - REVISED ELECTRICAL AND HYDRAULIC WIRING ON OILERS AND HYDRAULIC WIRING ON ELECTRO-HYD CONTROL. CORRECTION 16-PIN CONNECTOR DESCRIPTION.

**Carlton**  
PROFESSIONAL  
TREE EQUIPMENT

CHECKED BY: \_\_\_\_\_  
SP4012S-1E CURRENT 6/8/17(16/17)

SEE RADIO CONTROL MANUAL, INCLUDED IN THIS MANUAL, FOR MORE

**HYDRAULIC INLET ASSEMBLY**

ITEM NO	PART NO	DESCRIPTION	QTY
1	0300199	Work Section	1
2	0300142G	Hyd Pump 4012 –Bucher	1
3	0300354J1	3/4 Hose - 3/4 FJ45T- Dayco	1
4	0300212	3/4 JIC - 5/8 ORB - 6400-12-10	1
5	0300219	1/2 JIC - 1/2 ORB 90 - 6801-8	1
6	0300236	1/2 JIC-1/2 ORB- 6400-8	1
7	H250401	Hose Assembly	1
8	H250402	Hose Assembly	1

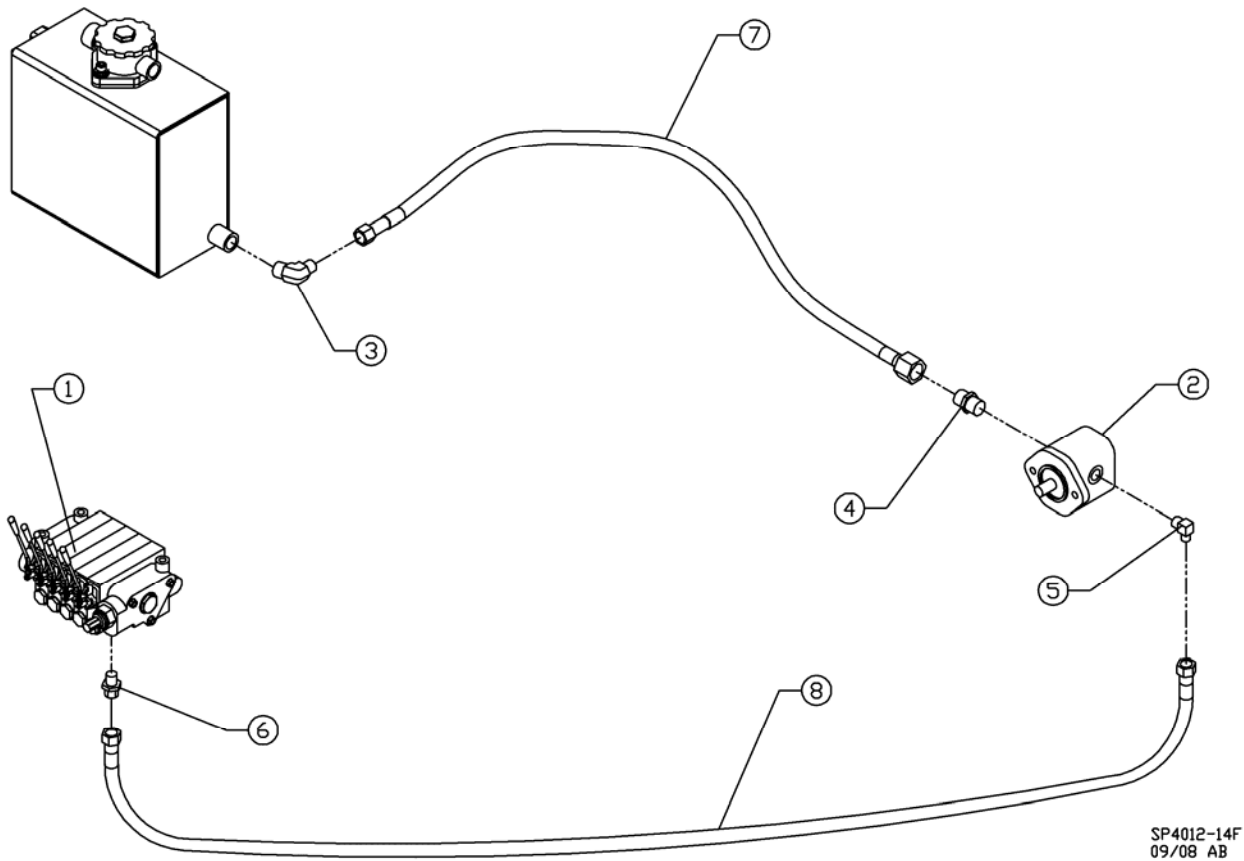

SP4012-14F  
 09/08 AB

**STEERING HYDRAULIC ASSEMBLY**

ITEM NO	PART NO	DESCRIPTION	QTY
1	0300199	Work Section	1
2	0300105A	Hydraulic Cylinder – 2x4	1
3	0300257	3/8 JIC- 1/2 ORB - 6400-6-8	2
4	0300279	3/8JIC-1/2ORB45 - 6802-6-8	2
5	H250426	Hose Assembly	1
6	H250425	Hose Assembly	2

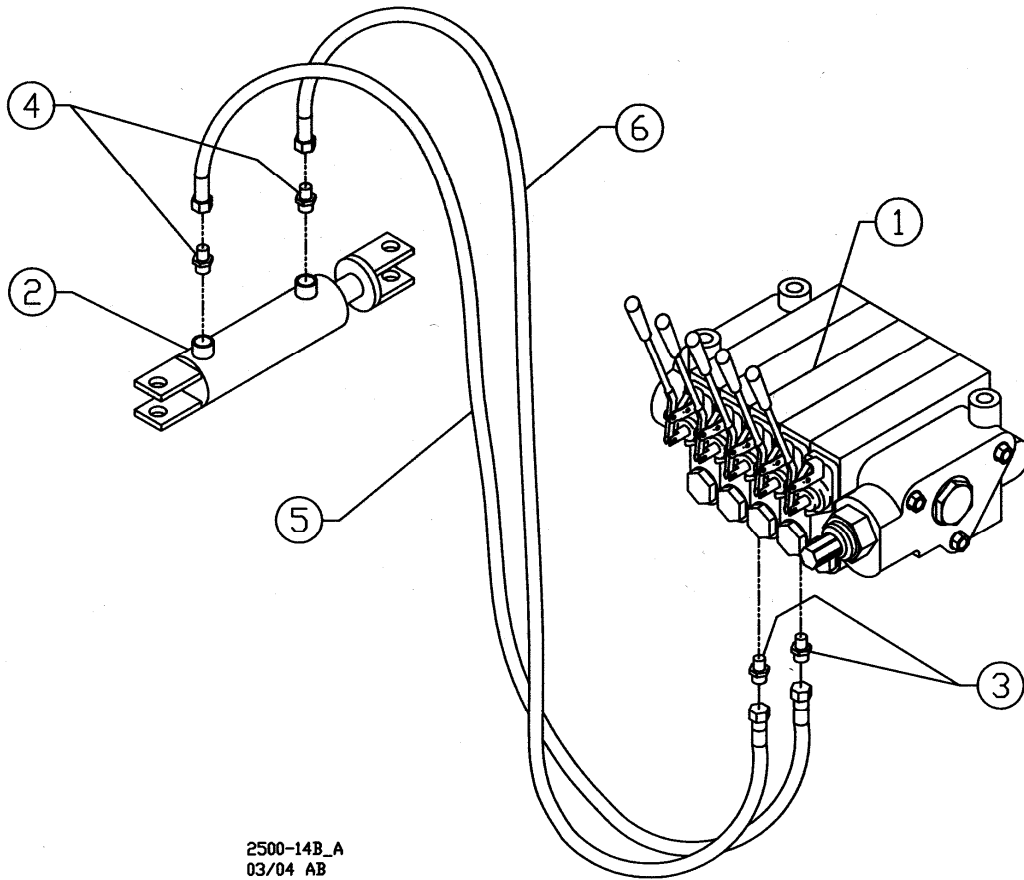

**TRACTION HYDRAULIC ASSEMBLY**

ITEM NO	PART NO	DESCRIPTION	QTY
1	0300199	Work Section	1
2	0300138	Vickers Needle Cartridge	1
3	0300127C	Deltroll Freewheel Valve Ctg	1
4	0300128	2500 Series-Parallel Module	1
5	0300120A	C/B Cartridge Valve - CBCG-LKN	2
6	0300118A1	Hyd Mtr - 2500-4 Drv 2 Mtrs-RH	1
7	0300118A11	Hyd Mtr - 2500-4 Drv 2 Mtrs-LH	1
8	0300128A	2500 Flow Divider Cartridge	1
9	0300128B	2500 4W 2P Cartridge	1
10	0300128C	2500 3W 2P Cartridge	1
11	0300128D	2500 Solenoid	1
12	0300257	3/8 JIC- 1/2 ORB - 6400-6-8	2
13	0300211	3/8 JIC-5/8 ORB - 6400-6-10	4
14	0300237	3/8 JIC-3/8 ORB - 6400-6-6	6
15	H250421	Hose Assembly	1
16	H250404	Hose Assembly	1
17	H250417	Hose Assembly	2
18	H250418	Hose Assembly	2

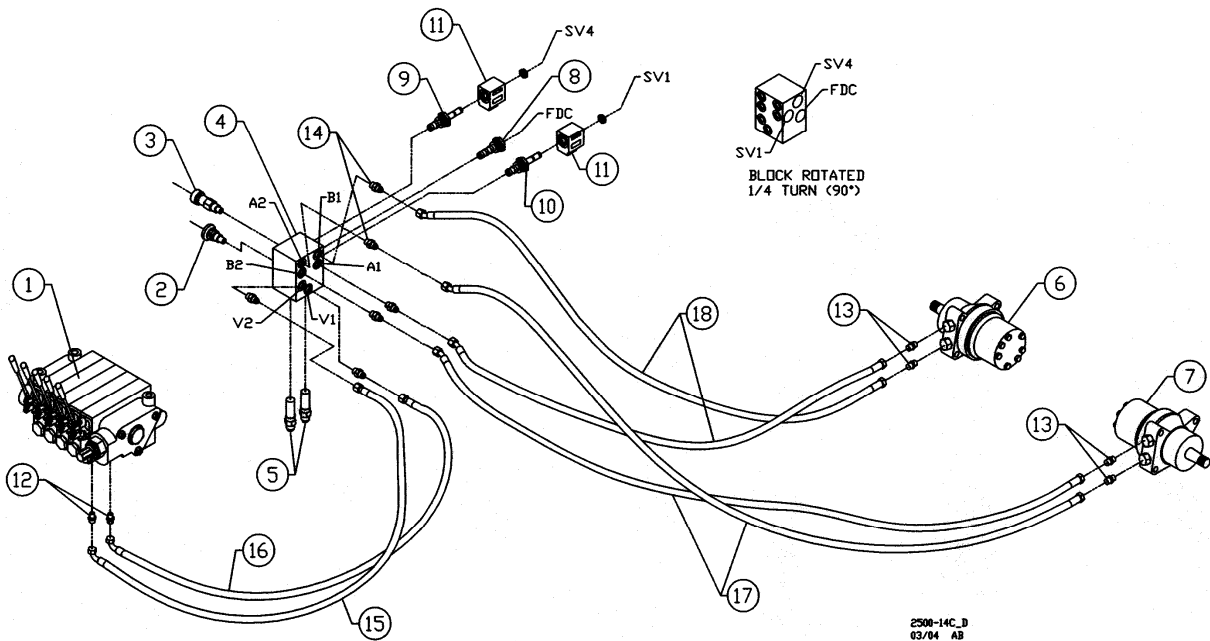

**LIFT HYDRAULIC ASSEMBLY**

ITEM NO	PART NO	DESCRIPTION	QTY
1	0300199	Work Section	1
2	0300122	Lift Valve Body - ECB	1
3	0300120	C/B Cartridge Valve - CBCA-LHN	1
4	0300105F	Hydraulic Cylinder - 3x12	1
5	0300257	3/8 JIC- 1/2 ORB - 6400-6-8	2
6	0300224	1/2FP-1/2FP-1/2MPTee5602-8	1
7	0300231	1/2MP-3/8MP Nipple - 5404-8-6	1
8	0300210	3/8 MP - 3/8 JIC - 2404-6-6	1
9	0300213	3/8 JIC - 1/4 MP 90 - 2501-6-4	1
10	H250414	Hose Assembly	1
11	H250413	Hose Assembly	1
12	H250412	Hose Assembly	1

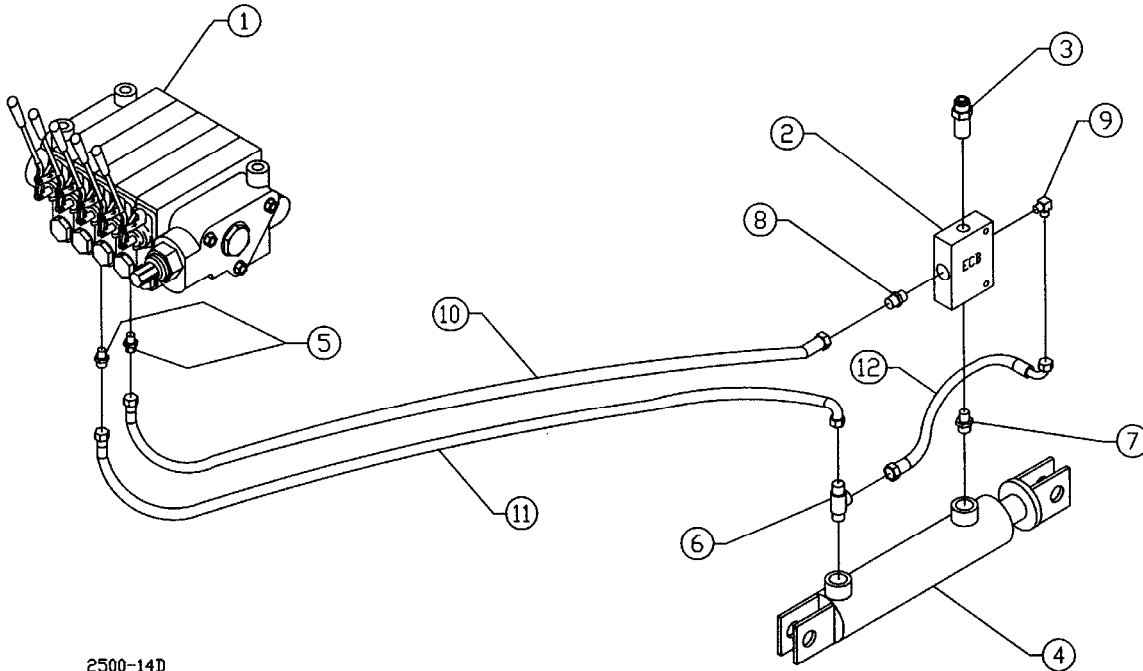

2500-14D

**TONGUE HYDRAULIC ASSEMBLY**

ITEM NO	PART NO	DESCRIPTION	QTY
1	0300199	Work Section	1
2	0300105B	Hydraulic Cylinder - 2 1/2 x 30	1
3	0300257	3/8 JIC- 1/2 ORB - 6400-6-8	2
4	0300215	3/8JIC-1/2MP90 - 2501-6-8	2
5	H250423	Hose Assembly	1
6	H250424	Hose Assembly	1

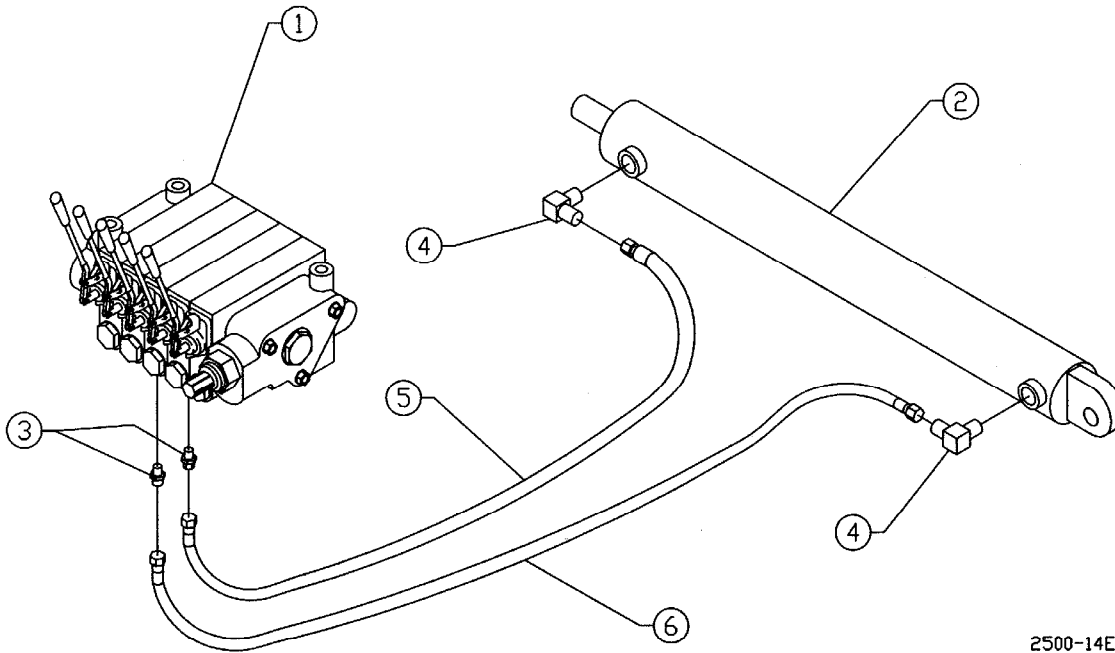



**SWING HYDRAULIC ASSEMBLY**

ITEM NO	PART NO	DESCRIPTION	QTY
1	0300199	Work Section	1
2	0300138	Vickers Needle Cartridge	1
3	0300127A	25-4 Swg Mnfld with Ndle Cvty	1
4	0300120A	C/B Cartridge Valve - CBCG-LKN	2
5	0300105	Hydraulic Cylinder - 2x4	2
6	0300257	3/8 JIC- 1/2 ORB - 6400-6-8	8
7	0300219	1/2 JIC - 1/2 ORB 90 - 6801-8	4
8	H250416	Hose Assembly	1
9	H250410	Hose Assembly	1
10	H250407	Hose Assembly	1
11	H250409	Hose Assembly	1
12	H250408	Hose Assembly	1
13	H250406	Hose Assembly	1

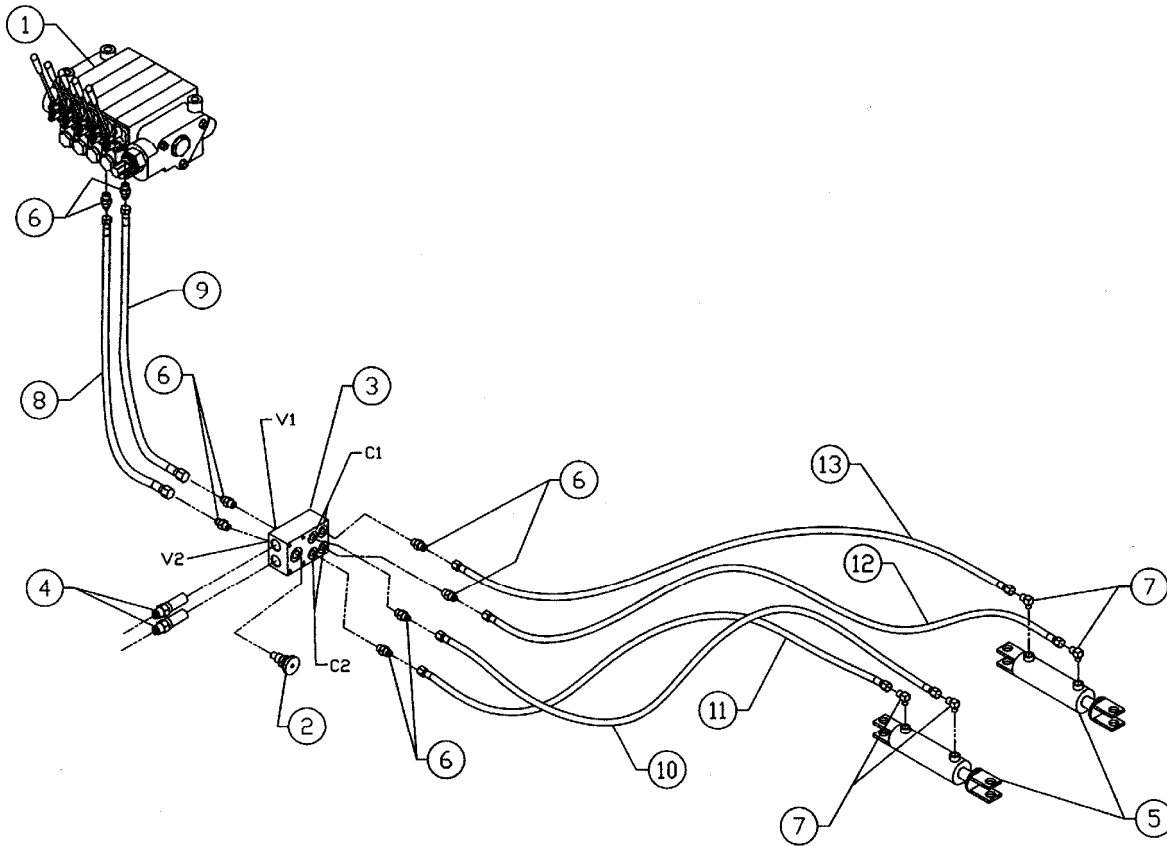

2500-14A\_B  
 03/04 AB

**HYDRAULIC RETURN ASSEMBLY**

ITEM NO	PART NO	DESCRIPTION	QTY
1	0300199	Work Section	1
2	0300135E	Hydraulic In Tank Filter STF	1
3	0300135F	Hydraulic In Tank Filter Eleme	1
4	0300266A	Hydraulic Site Gauge w/Temp	1
5	0300236	1/2 JIC-1/2 ORB- 6400-8	1
6	0300245A	1/2 JIC- 3/4 ORB - 6400-8-12	1
7	0150712H	7/16-14 x 1 1/2" SHC	2
8	0150412	7/16 Lock Washer	2
9	0150303B	7/16 Flat Washer	2
10	H250403	Hose Assembly	1

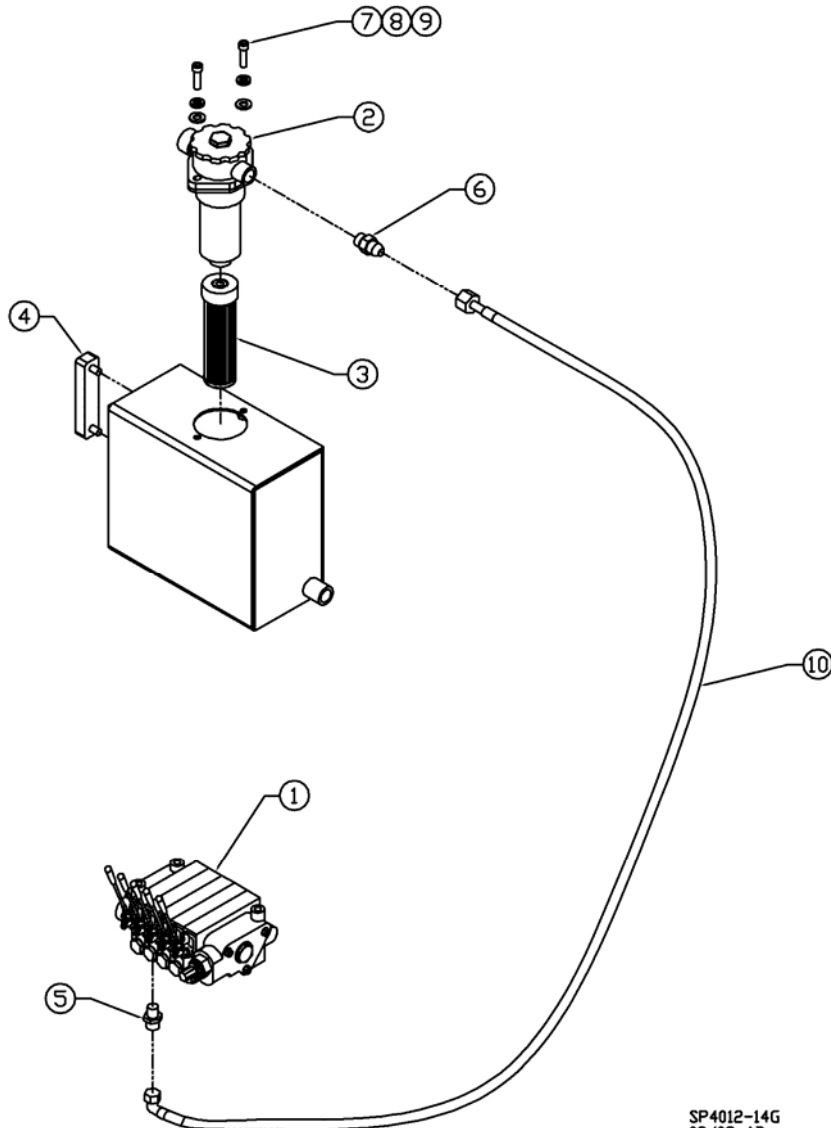

SP4012-14G  
 09/08 AB

**CONTROL VALVE ASSEMBLY**

ITEM NO	PART NO	DESCRIPTION	QTY
1	0300199F	Work Section - SVS1GA1AA	4
2	0300199G	Valve Section - SVH1BA1AA	1
3	0300199H	Prince Inlet Section - SVI	1
4	0300199I	Outlet Section – SVE	1
5	0300064	Relief Valve	1
6	0300261	Steel Plug, 1/2 SAE	2
7	0300072	O-Ring	1
8	0300069	Back-Up Washer	1
9	0300073	O-Ring	1
10	0300074	O-Ring	1
11	0300075	O-Ring	14
12	0300065	Relief Plug	10
13	0300199L	Valve Spool End Cap	5
14	0300060	Handle Flange	5
15	0300199M	Prince Handle Linkage	5
16	0300199N	Prince Valve Spool Extension	5
17	0300199K1	Valve Handle Kit	5
18	0300076	O-Ring	4
19	0300070	Spool Back-Up Washer	10
20	0300077	O-Ring	10
21	0300078	O-Ring	16
22	0300066	Load Check Poppet	5
23	0300067	Spring	5
24	0300068	Load Check Plug	5
25	0300071	Back-Up Washer	10
26	0300079	O-Ring	10

**NOTES:**

1. SVS work section seal kit - P/N 0300199ZA - Includes items 11,18,20,21,25.
2. SVH work section seal kit - P/N 0300199ZB - Includes items 10,11,20,21,25.
3. SVI inlet section seal kit - P/N 0300199ZC - Includes items 10,11.



CONTROL VALVE ASSEMBLY

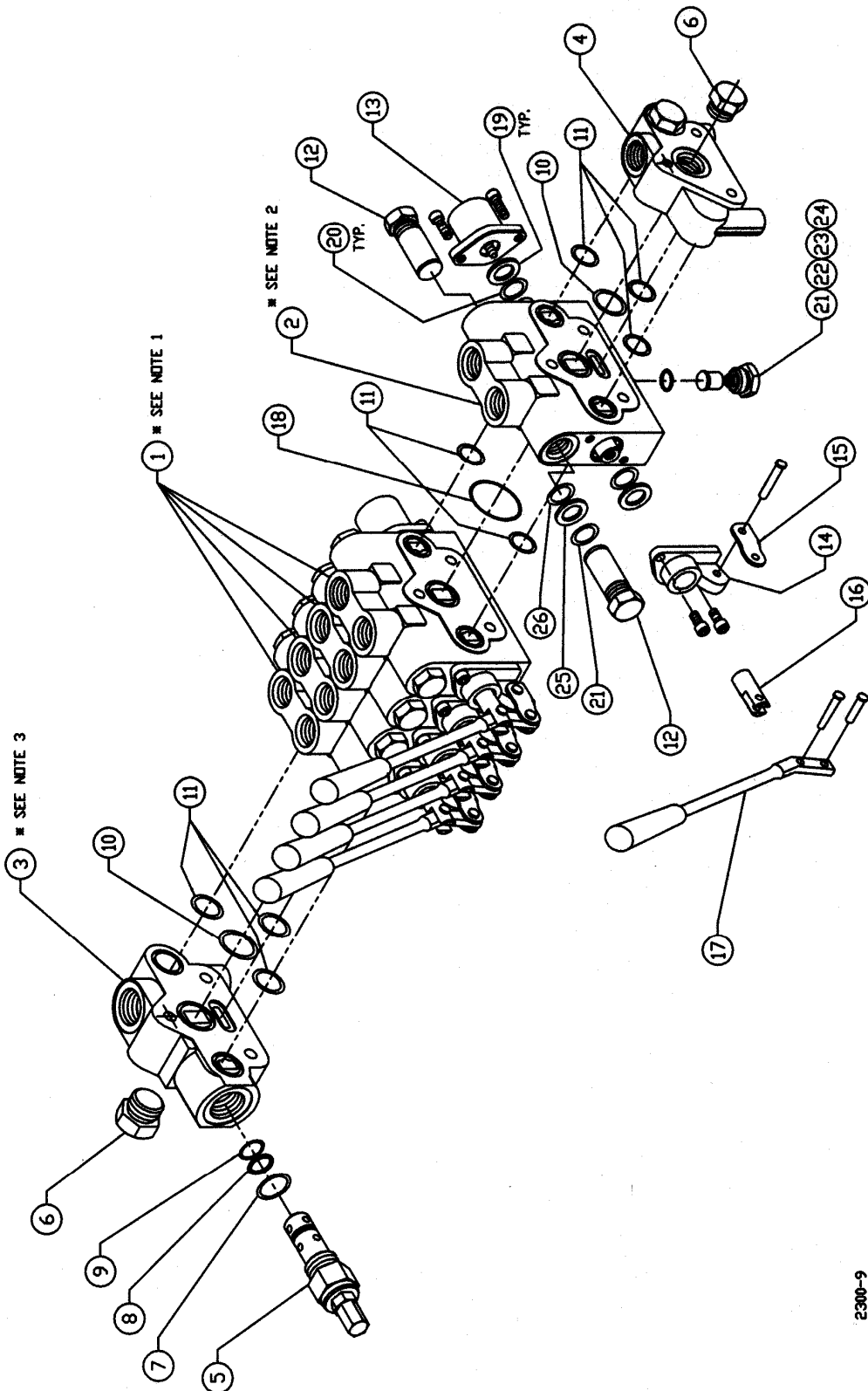

2300-9

**OPTIONAL:**  
**STEERING HYDRAULIC ASSEMBLY**  
 (ALL WHEEL DRIVE)

ITEM NO	PART NO	DESCRIPTION	QTY
1	0300199	Work Section	1
2	0300105W	Hydraulic Cylinder – 2 x 6	1
3	0300257	3/8 JIC- 1/2 ORB - 6400-6-8	2
4		1/2" O-Ring - 3/8" JIC 90°	2
5	H250426	Hose Assembly	1
6	H250425	Hose Assembly	2

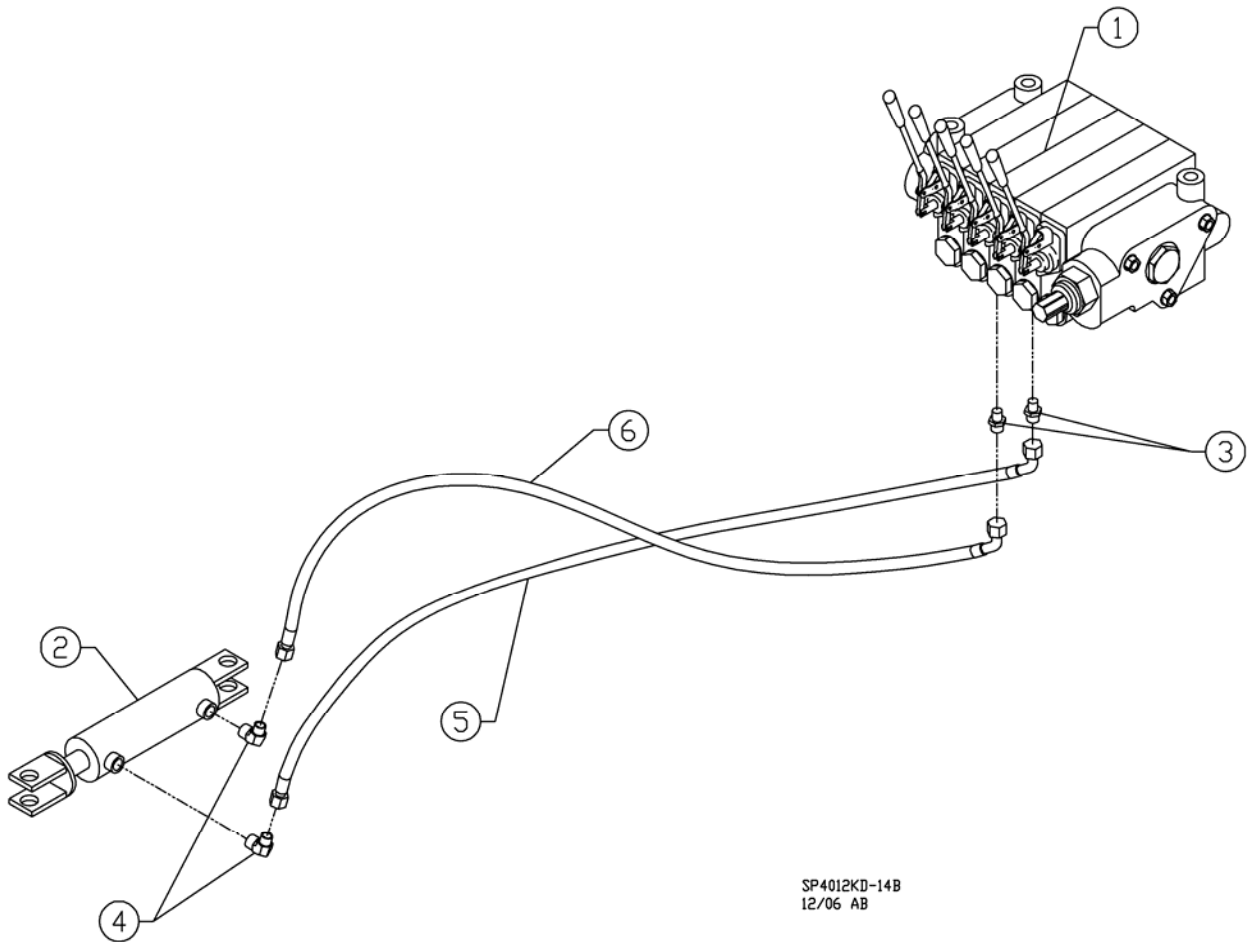

**OPTIONAL:**  
**TRACTION HYDRAULIC ASSEMBLY**  
 (ALL WHEEL DRIVE)

ITEM NO	PART NO	DESCRIPTION	QTY
1	0300199	Work Section	1
2	0300138	Vickers Needle Cartridge	1
3	0300127C	Deltroll Freewheel Valve Ctg	1
4	0300128	2500 Series-Parallel Module	1
5	0300120A	C/B Cartridge Valve - CBCG-LKN	2
6	0300118A1	Hyd Mtr - 2500-4 Drv 2 Mtrs-RH	2
7	0300118A11	Hyd Mtr - 2500-4 Drv 2 Mtrs-LH	2
8	0300128A	2500 Flow Divider Cartridge	1
9	0300128B	2500 4W 2P Cartridge	1
10	0300128C	2500 3W 2P Cartridge	1
11	0300128D	2500 Solenoid	2
12	0300257	3/8 JIC- 1/2 ORB - 6400-6-8	2
13	0300211	3/8 JIC-5/8 ORB - 6400-6-10	8
14	0300237	3/8 JIC-3/8 ORB - 6400-6-6	6
15	0300128E	SPC2	1
16		Hose Assembly	1
17		Hose Assembly	1
18		Hose Assembly	1
19		Hose Assembly	1
20		Hose Assembly	1
21		Hose Assembly	1
22		Hose Assembly	1
23		Hose Assembly	1

**OPTIONAL:  
TRACTION HYDRAULIC ASSEMBLY  
(ALL WHEEL DRIVE)**

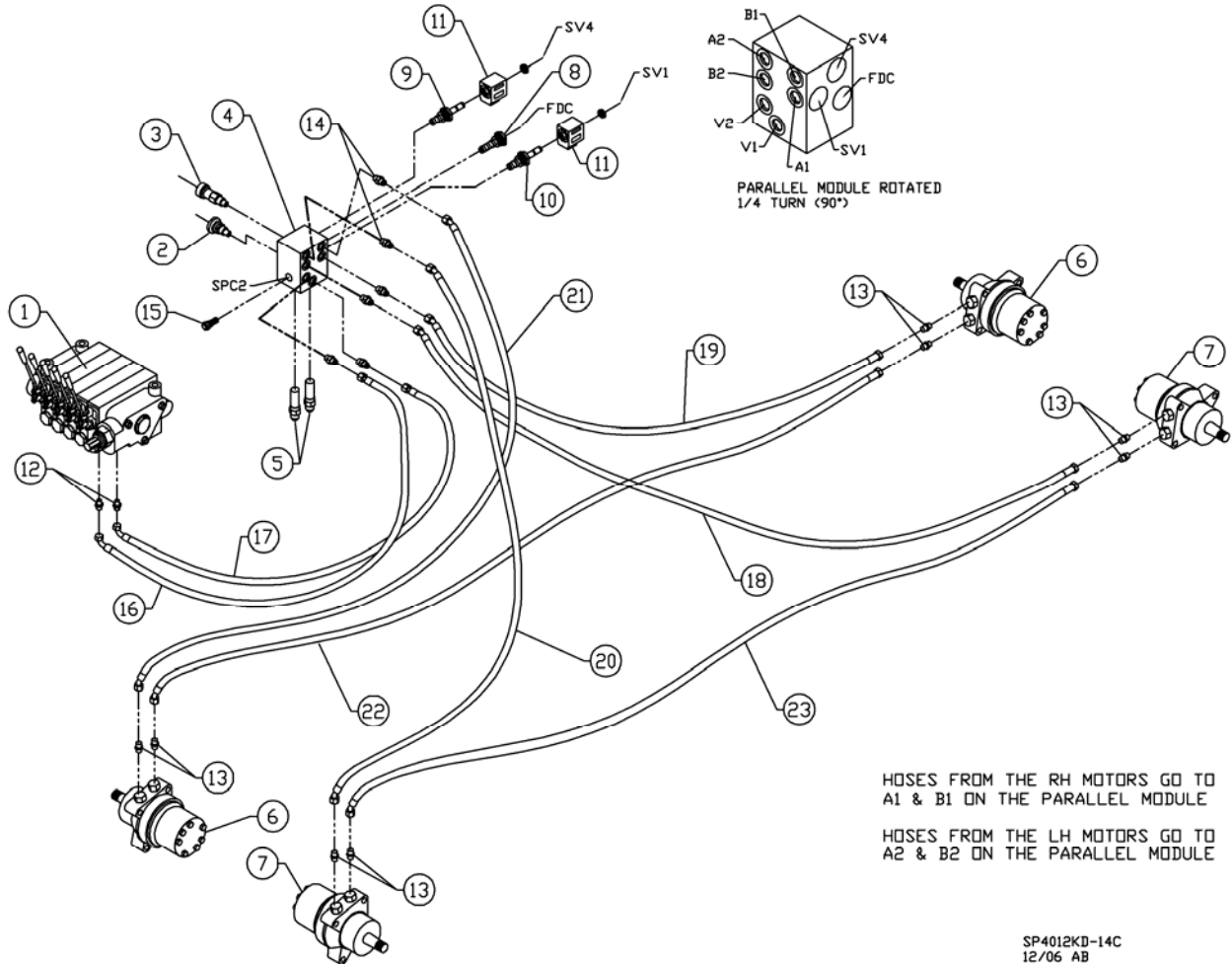

**OPTIONAL:  
 BLADE HYDRAULIC ASSEMBLY**

ITEM NO	PART NO	DESCRIPTION	QTY
1	0300199	Work Section	1
2	0300105A	Hydraulic Cylinder – 2x4	1
3	0300257	3/8 JIC- 1/2 ORB - 6400-6-8	2
4		1/2" O-Ring - 3/8" JIC 90°	2
5		Hose Assembly	1
6		Hose Assembly	1

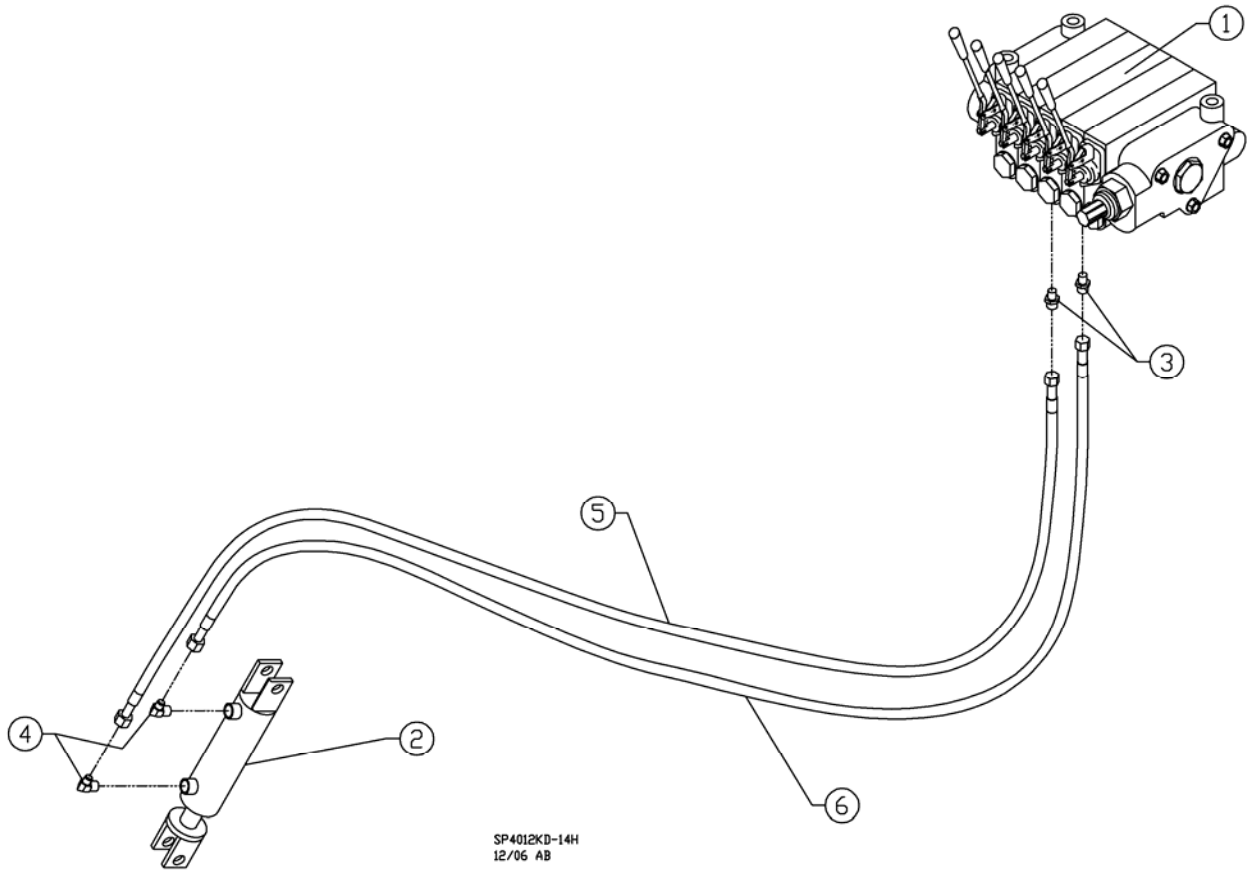



ITEM NO	PART NO	DESCRIPTION	QTY
1	05500091	Tire Assembly 25-4 5 Lug	2
2	0550102	Lug Nut – 1/2-20	10
3	2300289	R/H Steering Frame	1
4	2300290	L/H Steering Frame	1
5	0550208	E/Z Lube Grease Seal	2
6	0550209	Inner Bearing – 3500#	2
7	0550210	Inner Bearing Race – 3500#	2
8	0550212	Hub w/Cups & Studs	2
9	0550213	Outer Bearing Race – 3500#	6
10	0550214	Outer Bearing – 3500#	6
11	0550215	Spindle Washer	4
12	0550216	Spindle Jam Nut - 1”-14	4
13	0550217	Tang Washer	4
14	0550218	Grease Cap - E/Z Lube – 3500#	2
15	0550219	Rubber Plug for EZ Lube Cap	2
16	3504133	Steering Linkage	1
17	2300280	Weld-on Seal Ring	2
18	12G-1010	Shoulder Bolt, 5/8” x 1 1/4" (1/2-13)	2
19	0150305	5/8 Flat Washer	2
20	0300105	Hydraulic Cylinder - 2x4	1
21	0150801	Hardened Spring Bushing - 1”	2
22	0300105N	Prince Cyl. Pin – Short	2
23		1/4-28 x 2” HHCS	4
24	2300158	Ground Stake Rod - 2500	1
25	0150604	Lock Pin - 3/8 x 2 3/4	1
26	0150805	Hardened Spring Bushing - 5/8”	2
27	0150304	1/2 Flat Washer	2
28	0550104	Grease Seal – 10-9	2
29	0550109	End Cap – 3500#	2
30	0150206	1/2-13 Lock Nut	2

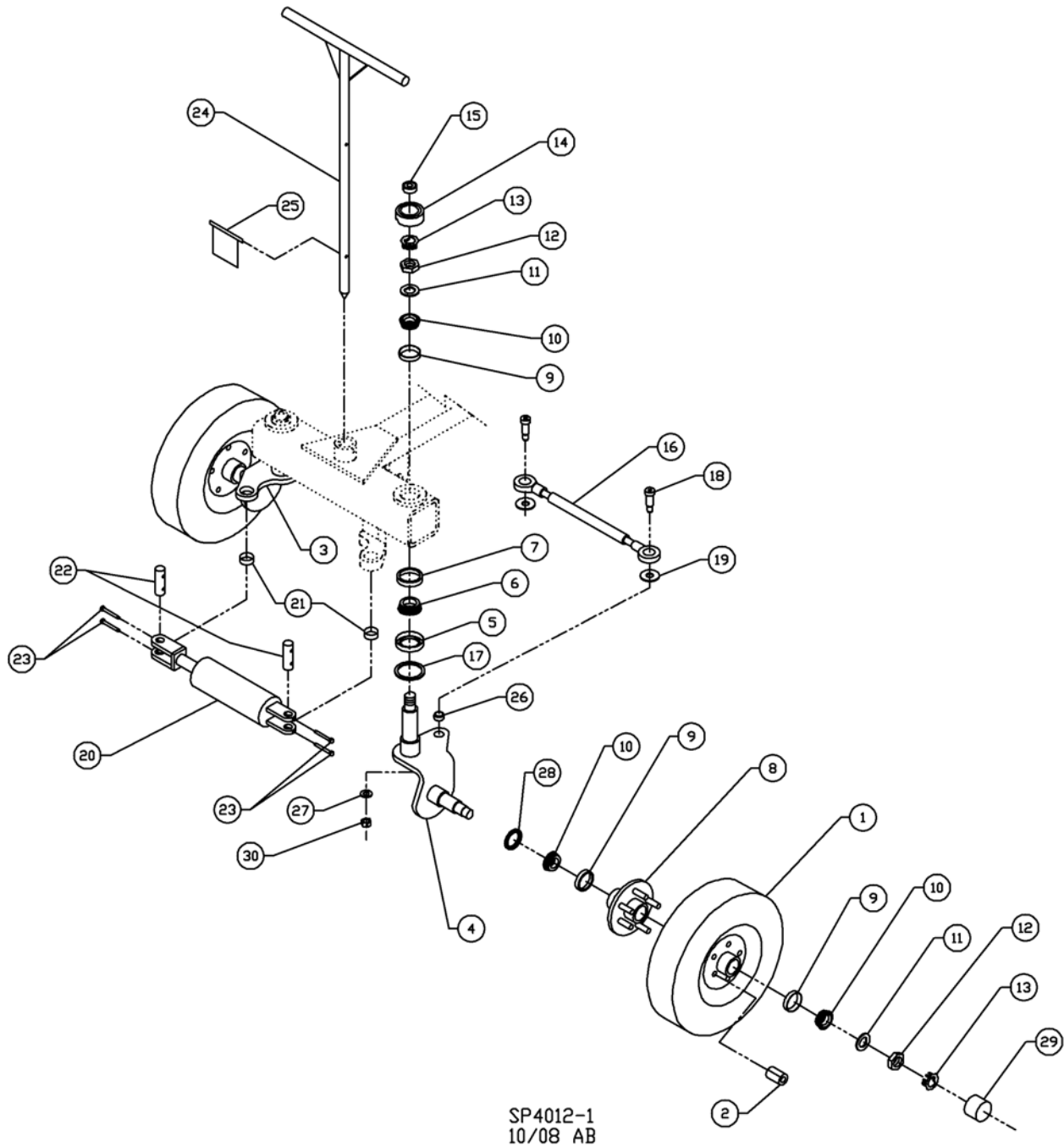

Part # 8 comes complete with parts # 9, 10, 11, 12, 13, 28, & 29 as shown for front wheel.  
 All parts can be purchased separately also.

**OPTIONAL:  
 ALL WHEEL DRIVE**

ITEM NO	PART NO	DESCRIPTION	QTY
1	05500091	Tire Assembly 25-4 5 Lug	2
2	0550102	Lug Nut – 1/2-20	10
3	14060030	Weldment, Mount, AWD Motor, RH	1
4	14060031	Weldment, Mount, AWD Motor, LH	1
5	0550208	E/Z Lube Grease Seal	2
6	0550209	Inner Bearing – 3500#	2
7	0550210	Inner Bearing Race – 3500#	2
8	0550009H	Rear Tapered Hub 25-4	2
9	0550213	Outer Bearing Race – 3500#	2
10	0550214	Outer Bearing – 3500#	2
11	0550215	Spindle Washer	2
12	0550216	Spindle Jam Nut - 1”-14	2
13	0550217	Tang Washer	2
14	0550218	Grease Cap - E/Z Lube – 3500#	2
15	0550219	Rubber Plug for EZ Lube Cap	2
16	14060033	Assy, Steering Linkage, AWD	1
17	12G-1010	Shoulder Bolt, 5/8” x 1 1/4” (1/2”-13)	2
18	0150305	5/8 Flat Washer	2
19	0150304	1/2 Flat Washer	2
20	0150206	1/2 Lock Nut	2
21	0300118A11	Hyd Mtr - 2500-4 Drv 2 Mtrs-LH	1
22	0300118A1	Hyd Mtr - 2500-4 Drv 2 Mtrs-RH	1
23	0300105W	Hydraulic Cylinder 2 x 6	1
24	0300105O	Prince Cyl. Pin - Long	2
25		Hitch Pin Clip (with 0300105O)	4
26	0150801	Hardened Spring Bushing - 1”	2
27	0150805	Hardened Spring Bushing - 5/8”	2
28	0150106G	1/2”-13 x 2 3/4” HHCS	8
29		Woodruff Key – 1/4” x 1” (with motor)	2
30	0150304	1/2 Flat Washer	8
31		Axle Nut – 1” Slotted Hex (with motor)	2
32	0150501	Cotter Pin – 3/16 x 2	2
33		Weld-on Seal Ring	2

**OPTIONAL:  
 ALL WHEEL DRIVE**

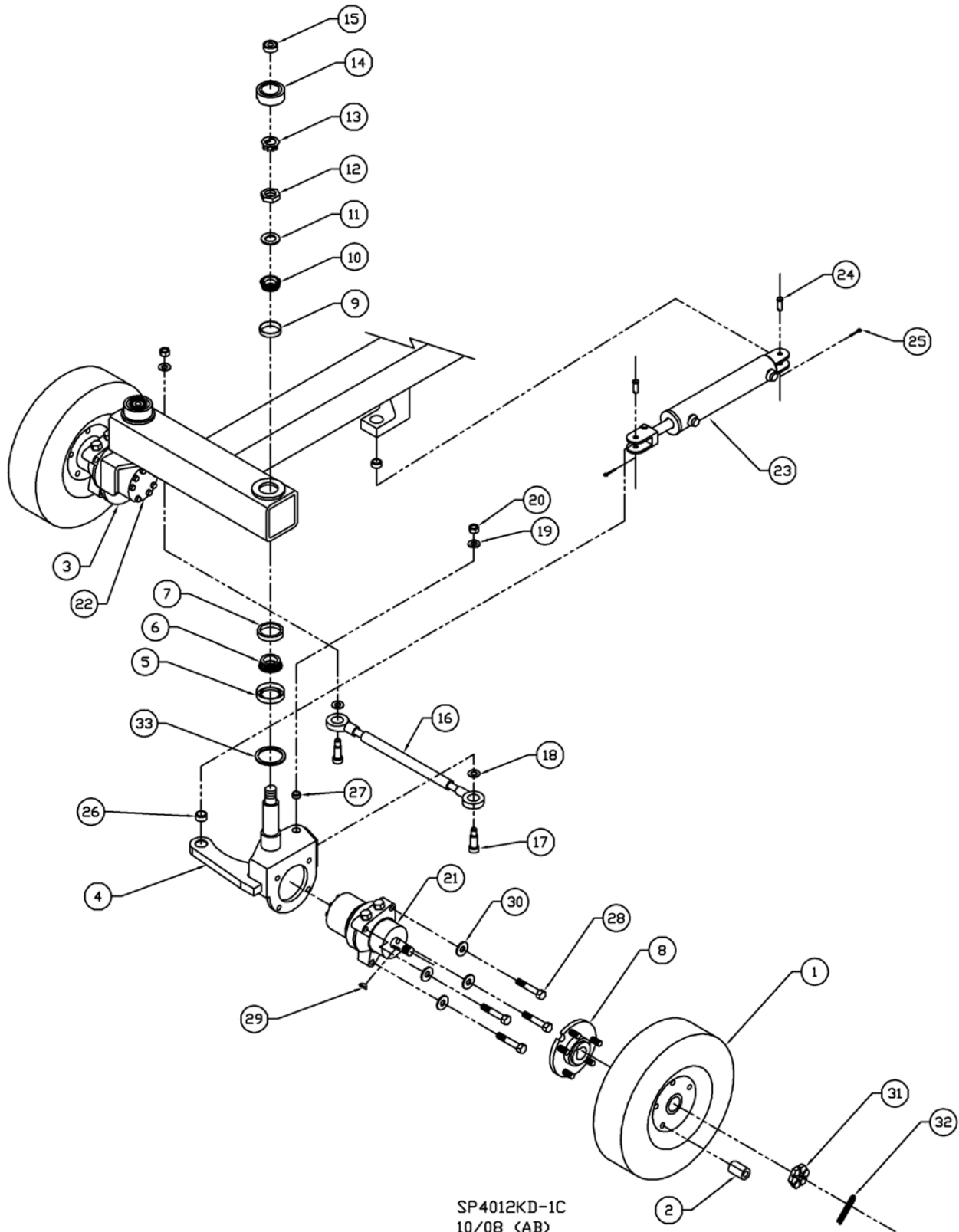

SP4012KD-1C  
 10/08 (AB)

ITEM NO	PART NO	DESCRIPTION	QTY
1	0300118A1	Hyd Mtr - 2500-4 Drv 2 Mtrs-RH	1
2	0300118A11	Hyd Mtr - 2500-4 Drv 2 Mtrs-LH	1
3	0150304	1/2 Flat Washer	8
4	0150106G	1/2"-13 x 2 3/4" HHCS	8
5	0150206	1/2-13 Lock Nut	8
6	0550009H	Rear Tapered Hub 25-4	2
7	05500091	Tire Assembly 25-4 5 Lug	2
8	0550102	Lug Nut - 1/2-20	10
9	0550009E	Axle Nut - 1" Slotted Hex	2
10	0150501	Cotter Pin - 3/16" x 2"	2

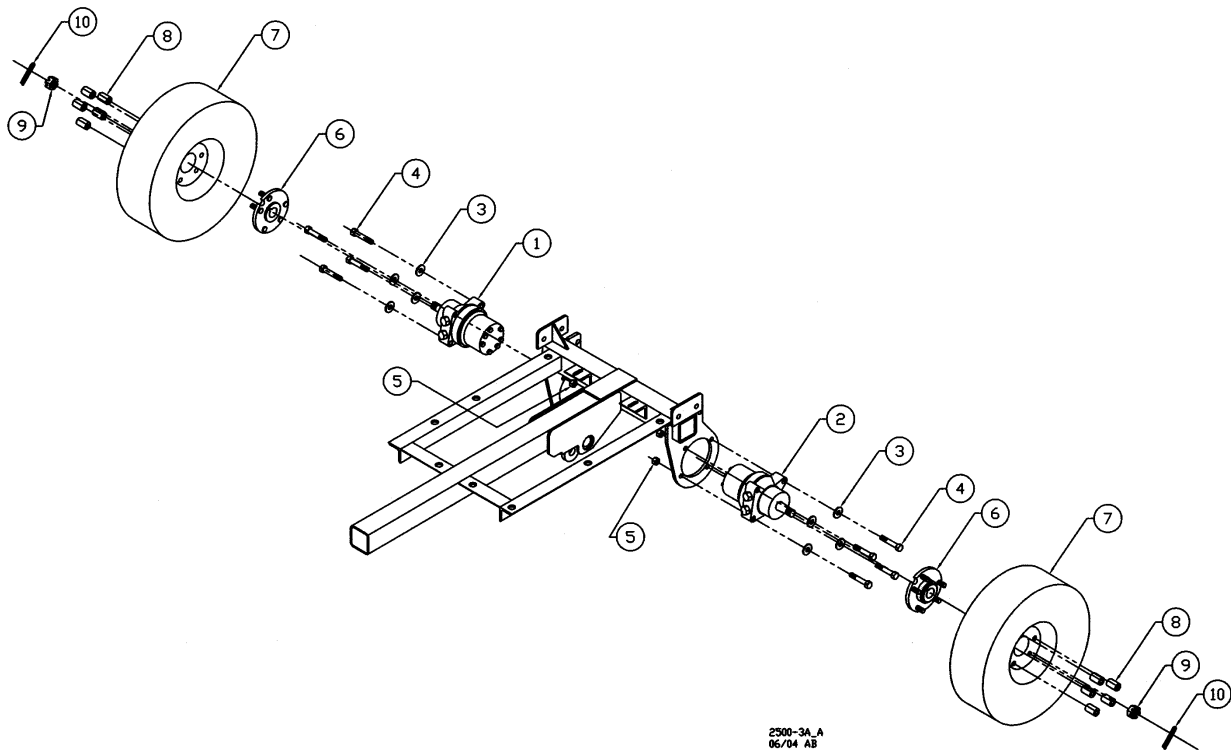

**DUAL WHEEL ASSEMBLY**

(Parts List For Two Assemblies, Only One Shown.)

ITEM NO	PART NO	DESCRIPTION	QTY
1	2500357A	Dual Wheel Hub – 5 Bolt	2
2	2500358A	Dual Wheel Spacer – 5 Bolt	2
3	05500091	Tire Assembly 25-4 5 Lug	2
4	0550102	Lug Nut – 1/2-20	10
5	0150308	1” SAE Flat Washer	2
6	0150409	1” Lock Washer	2
7	0150150A	1-8 x 7” HHCS	2

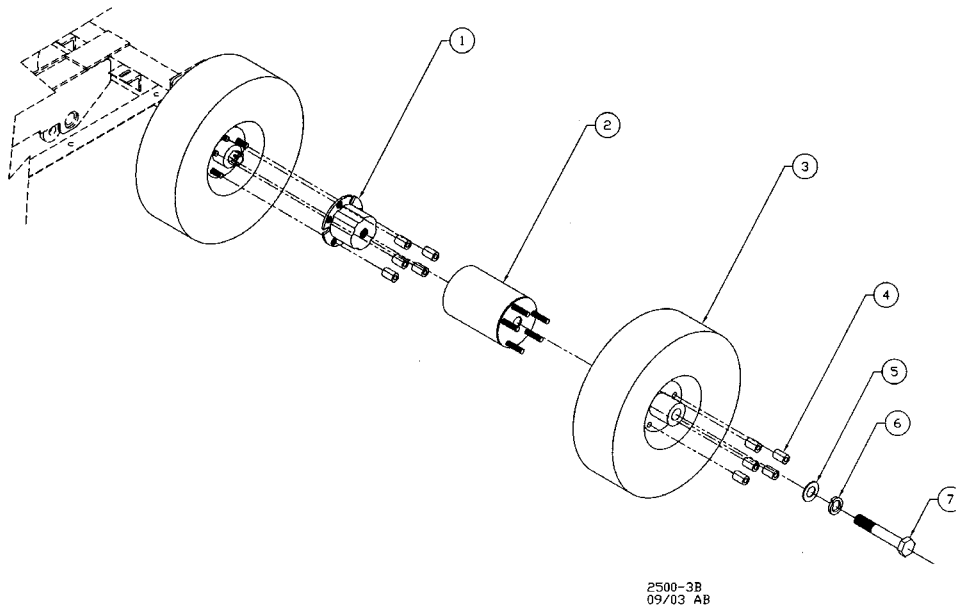

**ASSEMBLY INSTRUCTIONS**

1. Remove lug nuts and install inner hub.
2. Replace lug nuts and tighten.
3. Bolt wheel spacer to dual wheel and tighten with new lug nuts.
4. Place dual wheel up to rear wheel and bolt through center of wheel to inner hub.
5. Tighten.
6. Repeat for other side.

**LOWER PIVOT ASSEMBLY**  
**TWO WHEEL DRIVE WITH TONGUE EXTENSION**

ITEM NO	PART NO	DESCRIPTION	QTY
1	2300189	Lift Pivot Shaft - 2500	1
2	0150801	Hardened Spring Bushing - 1"	8
3	0150308	1" SAE Flat Washer	2
4	0150209	1-14 Hex Castle Nut	2
5	0150501	Cotter Pin - 3/16" x 2"	2
6	0300105F	Hydraulic Cylinder - 3x12	1
7	0300105O	Prince Cyl. Pin - Long	2
8		Hitch Pin Clip (with 0300105O)	2
◆ 9	2500162	Side Pivot Tube 2500	2
◆ 10	2500280	Side Pivot Gusset 2500	2
◆ 11	2300125	Pivot Shaft Tube 2500	1
12	0150600	Grease Fitting -1/4 NPT	3
13	H250429	Grease Hose Assembly - 42"	1
14	H250428	Grease Hose Assembly - 41"	1
15	H250427	Grease Hose Assembly - 40"	1
16	0300346	1/4 MJIC - 1/8 NPT- 2405-4-2	3

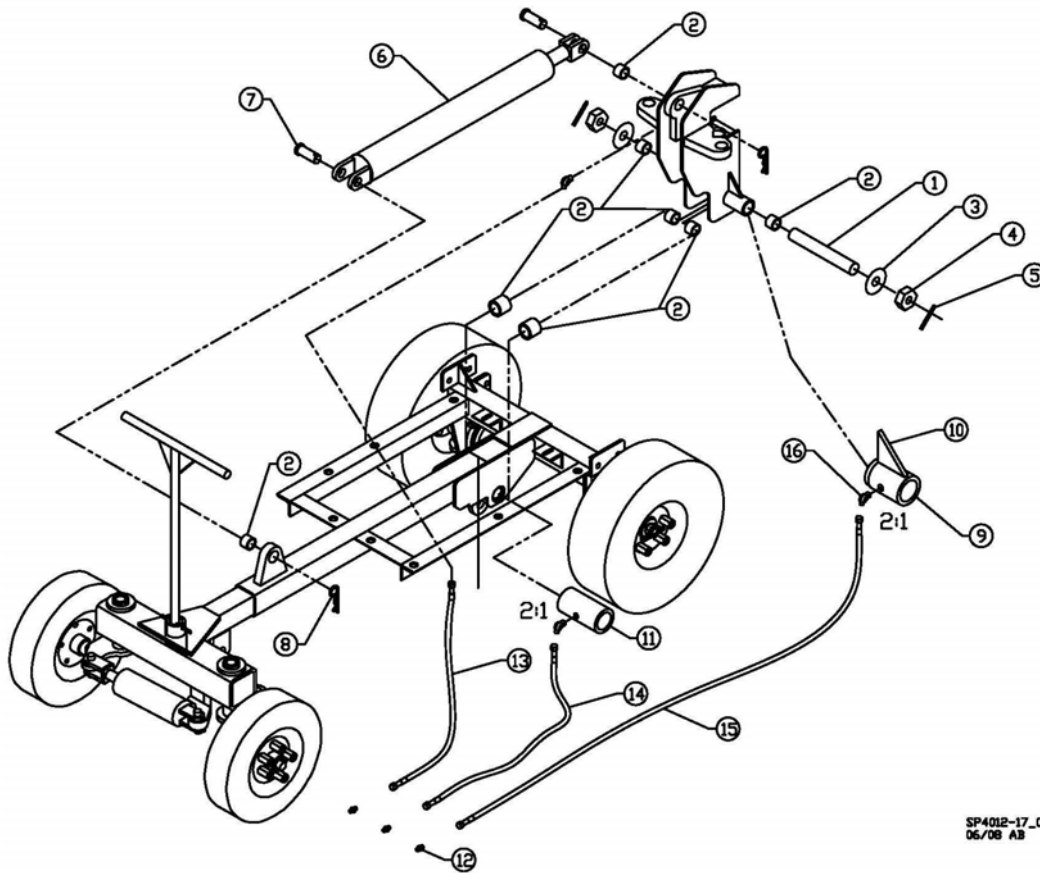

SP4012-17\_C  
 06/08 AB

◆ PARTS # 9 & 10 ARE WELDED TO THE PIVOT ASSEMBLY AFTER THE BOOM IS LEVEL  
 #11 IS WELDED IN THE FRAME ASSEMBLY

**UPPER PIVOT ASSEMBLY**

ITEM NO	PART NO	DESCRIPTION	QTY
1	2300159	Swing Pivot Shaft - 1" - 23/25	1
2	0150801	Hardened Spring Bushing - 1"	4
3	0500201	Race - 23/25 # 15250	2
4	0500121	Bearing - 1" - 23/25 # 15100	2
5	0500407	Seal - 23/25	2
6	2300255	Top Pivot Inner Bushing - 2500	1
7	2300256	Bottom Pivot Bushing - 2500	1
8	0150208	1-14 Hex Jam Nut	2
9	0150209	1-14 Hex Castle Nut	1
10	0150501	Cotter Pin - 3/16" x 2"	1
11	0150123	5/16-18 x 3/4 SHCP	6
12	0150124	5/16-18 x 3/4 FHSCP	6
13	2300257	Top Pivot Bushing - 2500	1
14	0300105N	Prince Cyl. Pin - Short	4
15		1/4"-28 x 2" HHCS	8
16	0500500	Snap Ring for 2500 Pivot 2.5"	2
17	0150308	1" SAE Flat Washer	1
18	0150600	Grease Fitting - 1/4 NPT	1
19		Pop-Out Valve	1
◆ 20	2300107	Boom Pivot Tube	1

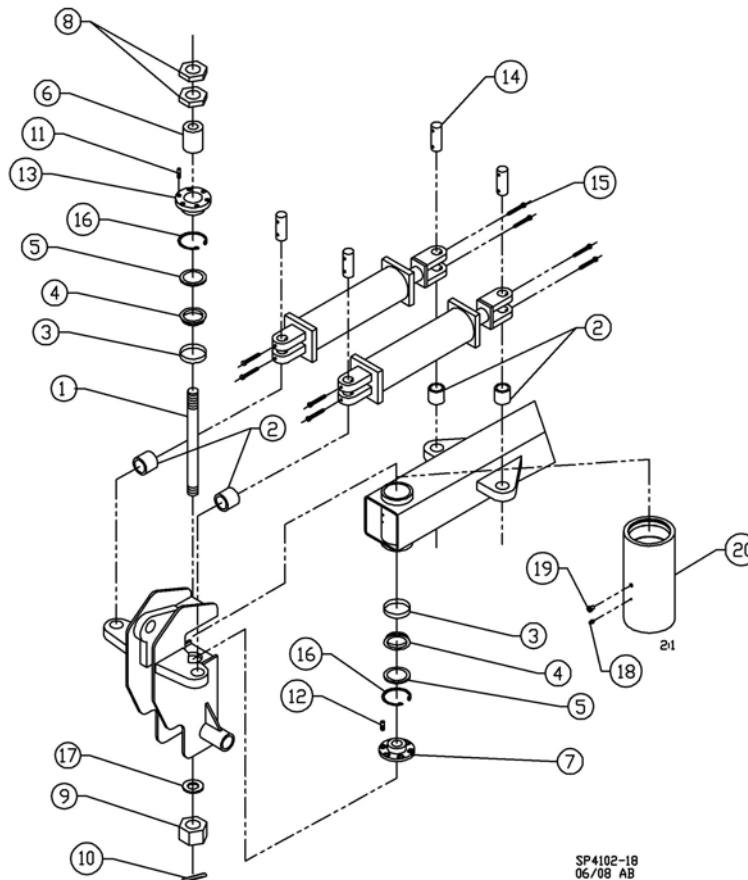

SP4102-18  
06/08 AB

◆ PART #20 IS WELDED IN THE PIVOT ASSEMBLY



**LOWER PIVOT ASSEMBLY  
ALL WHEEL DRIVE**

ITEM NO	PART NO	DESCRIPTION	QTY
1	2300189	Lift Pivot Shaft -2500	1
2	0150801	Hardened Spring Bushing - 1"	8
3	0150308	1" SAE Flat Washer	2
4	0150209	1-14 Hex Castle Nut	2
5	0150501	Cotter Pin - 3/16" x 2"	2
6	0300105F	Hydraulic Cylinder - 3x12	1
7	0300105O	Prince Cyl. Pin - Long	2
8		Hitch Pin Clip (with 0300105O)	2
◆ 9	2500162	Side Pivot Tube 2500	2
◆ 10	2500280	Side Pivot Gusset 2500	2
◆ 11	2300125	Pivot Shaft Tube 2500	1
12	0150600	Grease Fitting -1/4 NPT	3
13	H250429	Grease Hose Assembly - 42"	1
14	H250428	Grease Hose Assembly - 41"	1
15	H250427	Grease Hose Assembly - 40"	1
16	0300346	1/4 MJIC - 1/8 NPT- 2405-4-2	3

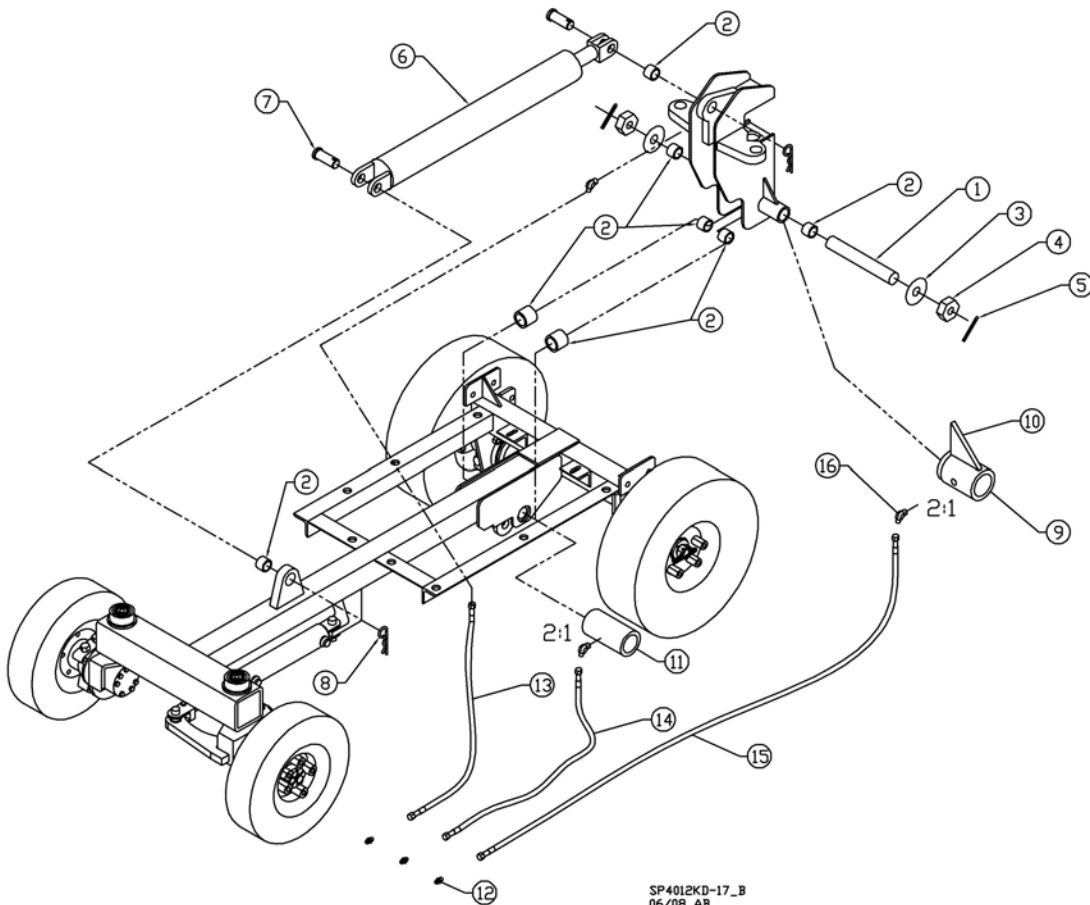

SP4012KD-17\_B  
06/08 AB

◆ PARTS # 9 & 10 ARE WELDED TO THE PIVOT ASSEMBLY AFTER THE BOOM IS LEVEL  
#11 IS WELDED IN THE FRAME ASSEMBLY

**SAFETY**

- **NEVER SERVICE A MACHINE WITH THE ENGINE RUNNING, SEVERE PERSONAL INJURY COULD OCCUR. TURN ENGINE OFF THEN REMOVE IGNITION KEY AND DISCONNECT POSITIVE BATTERY CABLE TO AVOID STARTING MACHINE ACCIDENTALLY.**
- **CUTTER WHEEL MUST BE DISENGAGED BEFORE TURNING ENGINE ON/OFF AND BEFORE SERVICING A MACHINE. OTHERWISE SEVERE PERSONAL INJURY COULD OCCUR AS WELL AS MACHINE DAMAGE.**
- **ALL MACHINE PARTS MUST COME TO A COMPLETE STOP AND HAVE TIME TO COOL COMPLETELY BEFORE SERVICING A MACHINE OR SEVERE INJURY COULD OCCUR, POSSIBLY SERIOUS BURNS AND/OR DISMEMBERMENT.**
- **DO NOT OPERATE A MACHINE WITHOUT A COMPLETE NUMBER OF TEETH IN THE CUTTER WHEEL PROPERLY INSTALLED. EXCESSIVE MACHINE VIBRATION WILL OCCUR CAUSING PREMATURE BEARING FAILURE AND EQUIPMENT DAMAGE.**
- **PLACE THE CUTTER WHEEL ON THE GROUND WHEN PERFORMING SERVICE ON A MACHINE.**

- There are twenty (20) teeth to a complete set on the model SP4012. Two (2) straight teeth, nine (9) left 45° teeth and nine (9) right 45° teeth.



- A locking pin is provided to hold cutter wheel in position during tooth removal and re-installation. Locking pin will only lock on outer teeth.  
**NEVER PLACE HAND ON CUTTER WHEEL TO HOLD IN PLACE WHILE CHANGING TEETH. BE SURE TO REMOVE PIN BEFORE OPERATING.**



- A Tooth Setting Gauge (P/N 0450111) is provided with each machine for proper tooth installation. Line all teeth up with the inside edge of the groove in the gauge. Set **ALL** teeth to this edge with gauge against pocket, not against cutter wheel.  
**See Cutter Wheel Assembly for breakdown.**



**TOOTH ARRANGEMENT**

- Inspect pockets, teeth and bolts for damage and replace as required.
- When replacing pockets, always replace new pockets across from each other in order to prevent vibration.
- Replacement teeth must be carbide tipped and have like design as provided with the machine.
- Use anti-seize on threads to prevent bolts from “freezing up” in cutter wheel.
- When replacing complete set of teeth, be sure to duplicate original factory tooth arrangement.
- Torque bolts to 150 ft/lbs.

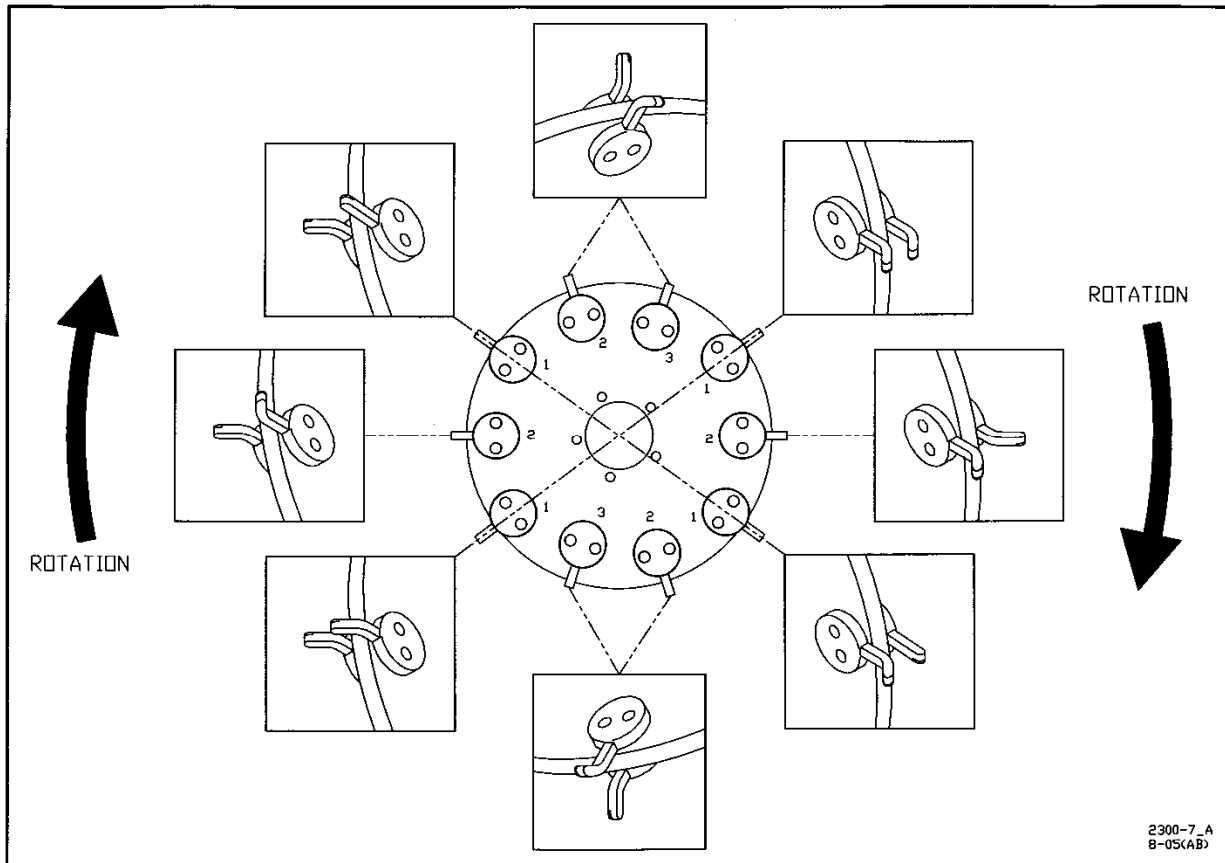

opposing outside pockets carry like arrangements of teeth to cancel vibration

- Straight teeth are mounted in **TWO OPPOSING OUTSIDE POCKETS.** A straight tooth must have a 45° tooth accompanying it in the same pocket set.
- The opposite pocket sets should have this same combination of straight and 45° teeth, except with positions reversed. Mounting these teeth opposite each other on the cutter wheel cancels damaging vibration.
- **Two Remaining Outside Pockets** must have 45° teeth overlapping centerline of wheel to make plunge cuts possible. Mount two left 45° teeth opposite two right 45° teeth.
- Inside pockets require 45° teeth mounted away from the wheel.

### OPTIONAL:

#### Sandvik® Dura Disk II Cutter Wheel

- If the machine is supplied with the optional Dura Disk II cutter wheel, there are thirty-two (36) teeth to a complete set. There are eight (12) Short Plow Bolt Bits (Carlton part #0450131) and twenty-four (24) Plow Bolt Bits (Carlton part #0450130).
- **DO NOT OPERATE A MACHINE WITHOUT A COMPLETE NUMBER OF TEETH IN THE CUTTER WHEEL PROPERLY INSTALLED. EXCESSIVE MACHINE VIBRATION WILL OCCUR CAUSING PREMATURE BEARING FAILURE AND EQUIPMENT DAMAGE.**
- A locking pin is provided to hold cutter wheel in position during tooth removal and re-installation.
- The locking pin will only lock in the deep slots of the outer teeth. Line the slot up with the locking pin slot and insert the pin to lock position. The pin will need to be removed and reinserted as wheel is rotated to change remaining teeth. (Some early machines will only lock on an outside 20° tooth.)
- **NEVER PLACE YOUR HAND ON THE CUTTER WHEEL TO HOLD IT IN PLACE WHILE CHANGING TEETH.**
- **BE SURE TO REMOVE THE PIN BEFORE OPERATING THE STUMP CUTTER.**
- The teeth do not require a setting gauge. The only requirement is to be installed in the proper direction and tightened to the proper torque as discussed in the next section.
- **When replacing a cutter wheel tooth, replace the tooth and nut as a set and use anti-seize on the threads.**



**TOOTH ARRANGEMENT**

- Inspect pockets, teeth and bolts for damage and replace as required.
- When replacing a cutter wheel tooth, replace the tooth and nut as a set and use anti-seize on the threads.
- When replacing teeth and pockets, also replace the teeth and pockets across from each other diagonally in order to maintain wheel balance and prevent vibration.
- All teeth and pockets are of a specific design and must be replaced with original manufacturer’s replacement parts. Replacement teeth must be carbide tipped.
- When replacing complete set of teeth, be sure to duplicate original factory tooth arrangement. SEE DIAGRAM BELOW.
- The seating surfaces of the tooth and pocket are formed, but make sure the tooth is inserted with the carbide facing the direction of rotation.
- The pictured view is the engraved side of the wheel. The wheel is engraved with outside pocket numbers, outside pocket angle/direction (20 R or 20 L), and wheel rotation. (The engraved side of wheel is marked left side of wheel; this is for manufacturing purposes only. It does not refer to the left side of the machine as described in the General Information section.)
- Outside pocket teeth are Short Plow Bolt Bits. These pockets are angled and welded in place. You can switch teeth from one outside pocket to a pocket that is the opposite direction to prolong tooth life, such as switching a tooth from a 20 R with a tooth from a 20 L pocket. The cutting edge is the corner and this will turn the opposite corner out for use.
- These teeth are tightened with Stover Lock Nuts. Torque on Stover locking nuts is not to exceed 270 ft/lbs.
- All teeth on cutter wheel sides are Plow Bolt Bits. When changing these teeth you must remove both teeth in the same pocket, one on each side of the wheel. When the nuts are torqued, the pocket is jammed and the teeth can only be removed this way.
- These teeth are also tightened with Stover Lock Nuts. Torque on Stover locking nuts is not to exceed 270 ft/lbs.
- The pocket will receive wear when cutting and can be switched from one side of the cutter wheel to the other to prolong life. Remember the teeth must be replaced in the original position on each side of the wheel.

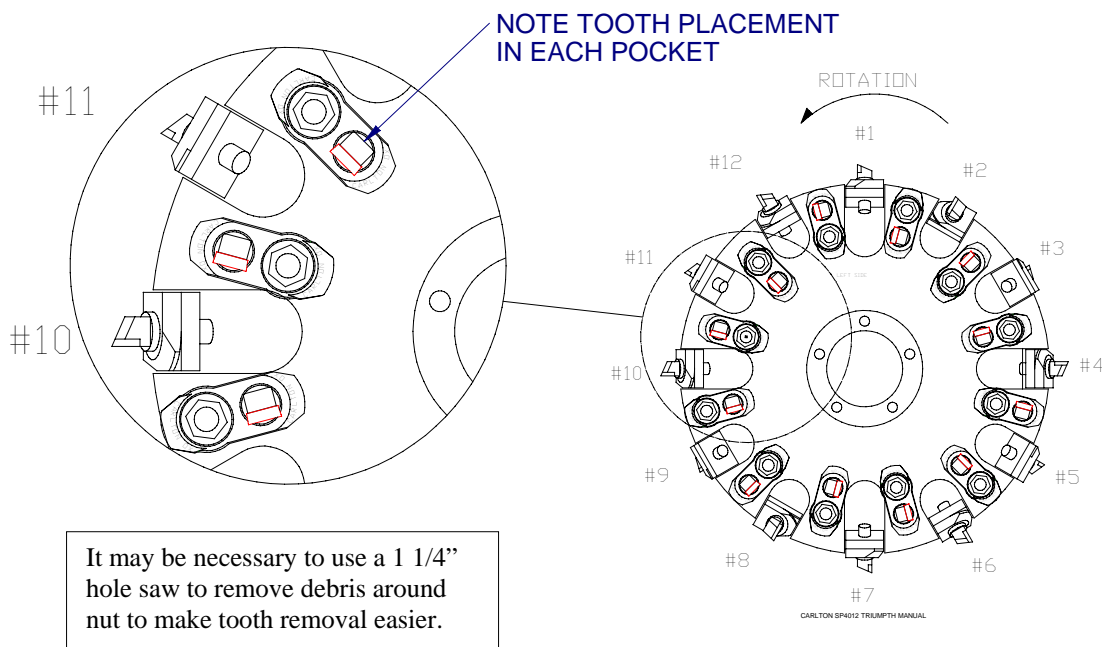

**TOOTH SHARPENING**

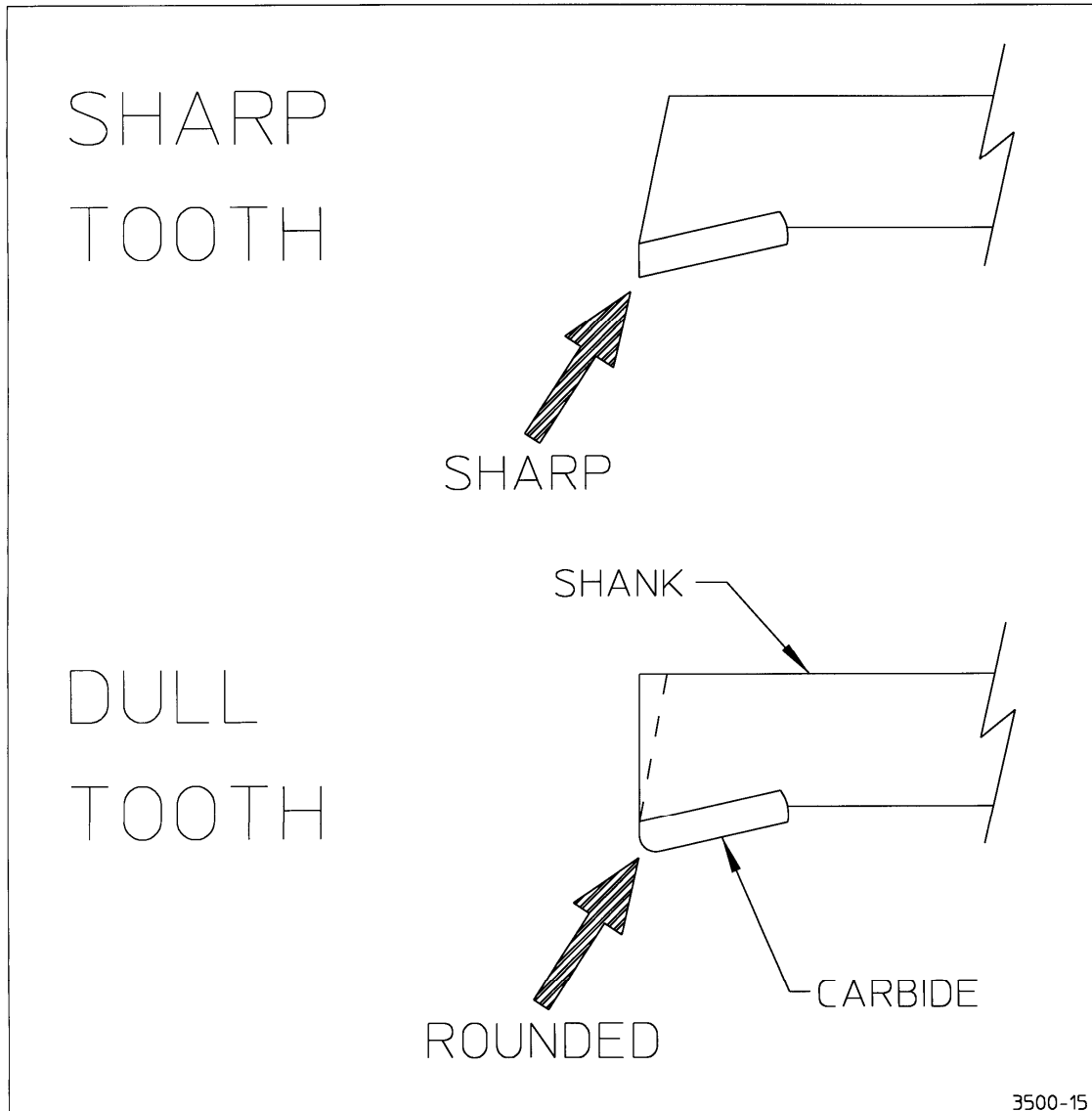

Begin by chamfering shank back past edge of carbide. You do this because if it is not back far enough the shank will hit the stump and not the carbide, thus causing a lot of vibration. Once the shank is angled far enough back, then begin sharpening carbide.

- **Cut shank with a standard rock and cut carbide with a silicone carbide or diamond rock.**  
**CAUTION: GRINDING CARBIDE CAN BE A HEALTH HAZARD. Use facemask to prevent breathing in harmful material while grinding.**

**POLY CHAIN® BELT ASSEMBLY**

ITEM NO	PART NO	DESCRIPTION	QTY
1	2300249	PC Belt Guard 2500	1
2	0150117	3/8"-16 x 1" Carriage Bolt	4
3	0150303	3/8" Flat Washer	4
4	0150207	3/8"-16 Lock Nut	4
5	0250115A	PC Sprkt 8M-40S-62 Taper Lock	2
6	0250115F1	2012 1 11/16" Taper Lock Bshn	2
7	0150712H	7/16"-14 x 1 1/2" SHC	4
8	0400112	PC 2300 2500 SP4012 8M-1200-62	1
9	2300225	PC Guard Bottom - 2500	1
10	0150116	5/16"-18 x 1" Hex Cap Screw	4
11	0150212	5/16"-18 Lock Nut	4
12	2300248	PC Guard Cover - 2500	1
13	0150118	3/8"-16 x 1" HH Bolt	8
14	0150404	3/8" Lock Washer	8

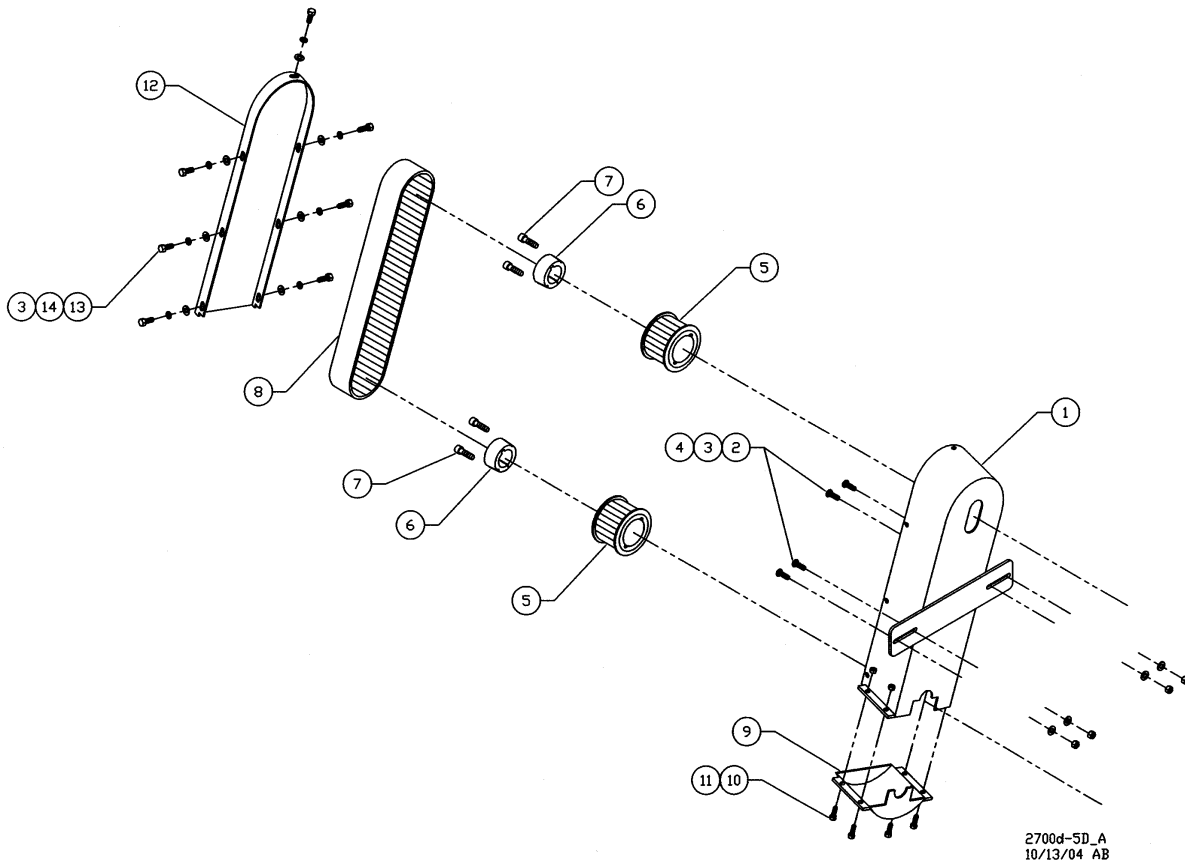

**CUTTER WHEEL ASSEMBLY**

ITEM NO	PART NO	DESCRIPTION	QTY
1	2700D184	Cutter Wheel Shaft 1 11/16"	1
2	0500113	Bearing – 1 11/16" – Link Belt	2
3	0150125B	5/8"-11 x 2 3/4" HHCS	4
4	0150305	5/8" Flat Washer	8
5	0150216	5/8"-11 Lock Nut	4
6	A160T013	Key - 3/8 x 1 7/8	1
7	A160T014	Key - 3/8 x 3	1
8	0250122	Bushing - 35/44 JS -SK 1 11/16	1
9	2300186	Cutter Wheel – 23/25	1
10	2300188	Cutter Wheel Hub – SK600A	1
11	2700D194	2 1/2 CW Shaft Washer- 1 11/16	1
12	2700D195	3 1/2 CW Shaft Washer- 1 11/16	1
13	0250115A	PC Sprkt 8M-40S-62 Taper Lock	1
14	0250115F1	2012 1 11/16" Taper Lock Bshn	1
15	0150712H	7/16"-14 x 1 1/2" SHC	2
16	2300197	Shaft Washer 1 7/16"	1
17	0150106B	1/2"-13 x 1 1/4" Hex Cap Screw	1
18	0450106	Round Pocket - C/S	10
19	0450107	Round Pocket - Thd.	10
20	0450101	Tooth - Straight	2
21	0450102	Tooth - Right 45 Degree	9
22	0450103	Tooth - Left 45 Degree	9
23	0450109	Tooth Bolt - 5/8-18 x 2 1/8"	20



**CUTTER WHEEL ASSEMBLY**

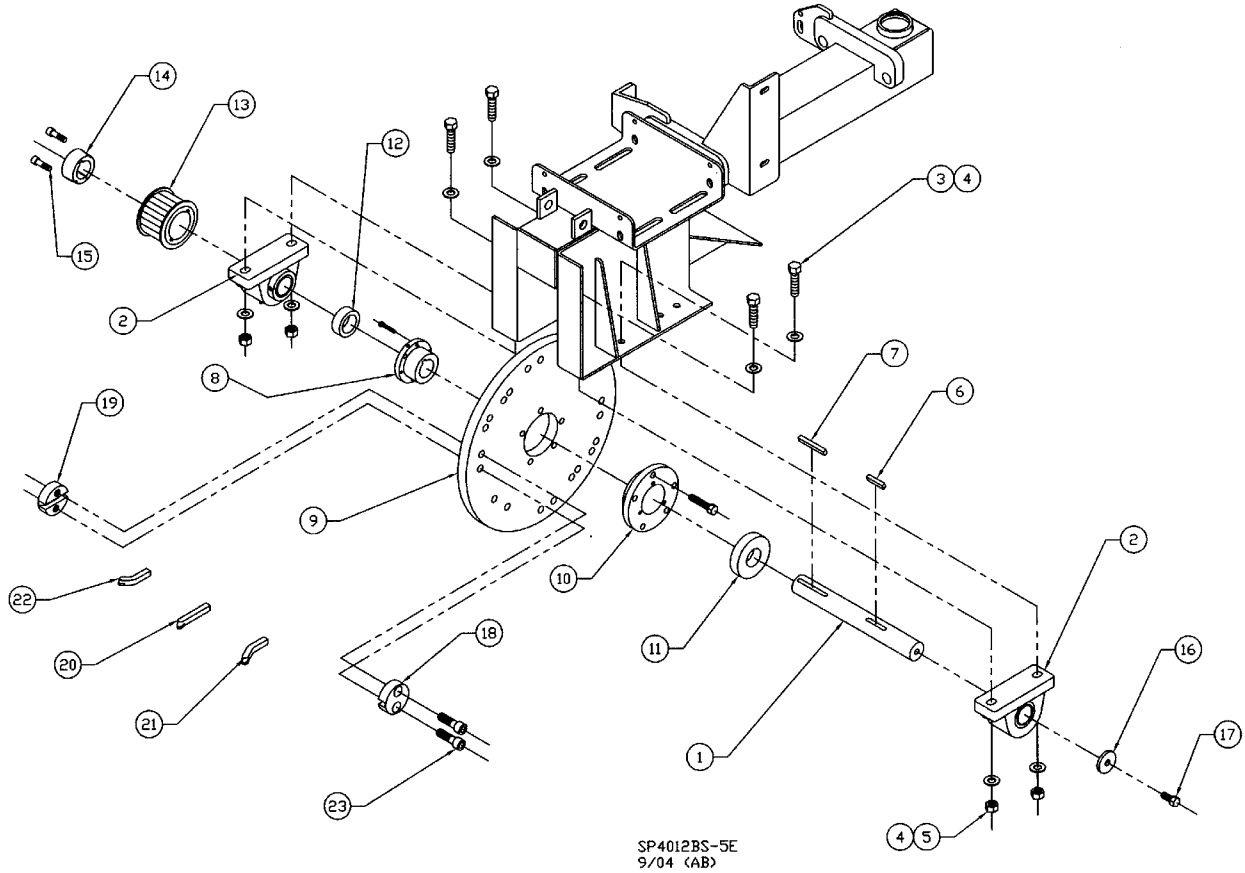

**CUTTER WHEEL ASSEMBLY**  
 (SANDVIK WHEEL OPTION)

ITEM NO	PART NO	DESCRIPTION	QTY
1	2700D184	Cutter Wheel Shaft 1 11/16"	1
2	0500113	Bearing – 1 11/16" – Link Belt	2
3	0150125B	5/8"-11 x 2 3/4" HHCS	4
4	0150305	5/8" Flat Washer	8
5	0150216	5/8"-11 Lock Nut	4
6	A160T013	Key - 3/8 x 1 7/8	1
7	A160T014	Key - 3/8 x 3	1
8	0250122	Bushing - 35/44 JS -SK 1 11/16	1
9	14030053	Sandvik Cutter Wheel Weldment	1
10	2300188	Cutter Wheel Hub - SK600A	1
11	2700D194	2 1/2 CW Shaft Washer- 1 11/16	1
12	2700D195	3 1/2 CW Shaft Washer- 1 11/16	1
13	0250115A	PC Sprkt 8M-40S-62 Taper Lock	1
14	0250115F1	2012 1 11/16" Taper Lock Bshn	1
15	0150712H	7/16"-14 x 1 1/2" SHC	2
16	2300197	Shaft Washer 1 7/16"	1
17	0150106B	1/2"-13 x 1 1/4" Hex Cap Screw	1
18	0450130	JP Sandvik Plow Bolt Tooth	24
19	0450131	JP Sandvik Short P/B Tooth	8
20	0450132	JP Sandvik Plow Bolt Holder	24
21	0450125	Sandvik Stover Jam Nut	32

**CUTTER WHEEL ASSEMBLY  
(SANDVIK WHEEL OPTION)**

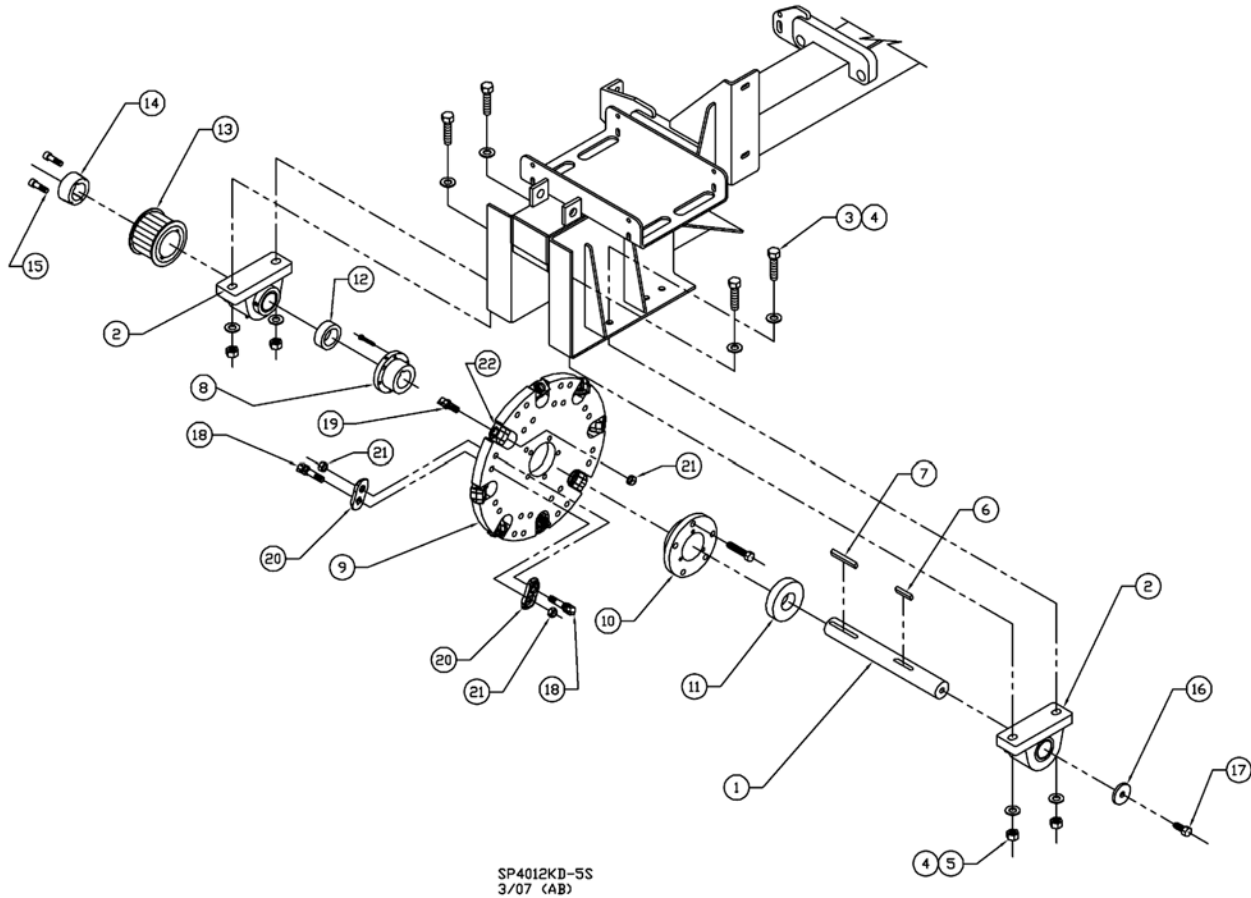



ITEM NO	PART NO	DESCRIPTION	QTY
1	2300134	2500 Deck Plate - R/H	1
2	2300135	2500 Deck Plate - L/H	1
3	0150119	3/8-16 x 3/4 Carriage Bolt	30
4	0150303	3/8 Flat Washer	34
5	0150207	3/8-16 Lock Nut	34
6	2300310	Front Rubber Chip Guard	1
7	2300311	Side Rubber Chip Guard	2
8	0150133H	3/4-10 x 6" Hex Head Bolt	1
9	2300218	Chip Guard Front Bracket	2
10	2300217	Chip Guard Side Bracket	2
11	2300193	Pan Guard - 2500	1
12	0150106B	1/2-13 x 1 1/4" Hex Cap Screw	2
13	0150206	1/2-13 Lock Nut	2
14	2300221	Boom Chip Guard Deck	1
15	0150117	3/8-16 x 1" Carriage Bolt	4
16	2300313	Front Boom Rubber Chip Guard	1
17	2300312	Side Boom Rubber Chip Guard	2
18	2300234	Chip Guard Bracket	4
19	2300261	Cutter Wheel Flap - 2500	1
20	0150211	3/4-10 Lock Nut	1
21	0150116	5/16-18 x 1" Hex Cap Screw	1
22	0150212	5/16-18 Lock Nut	1

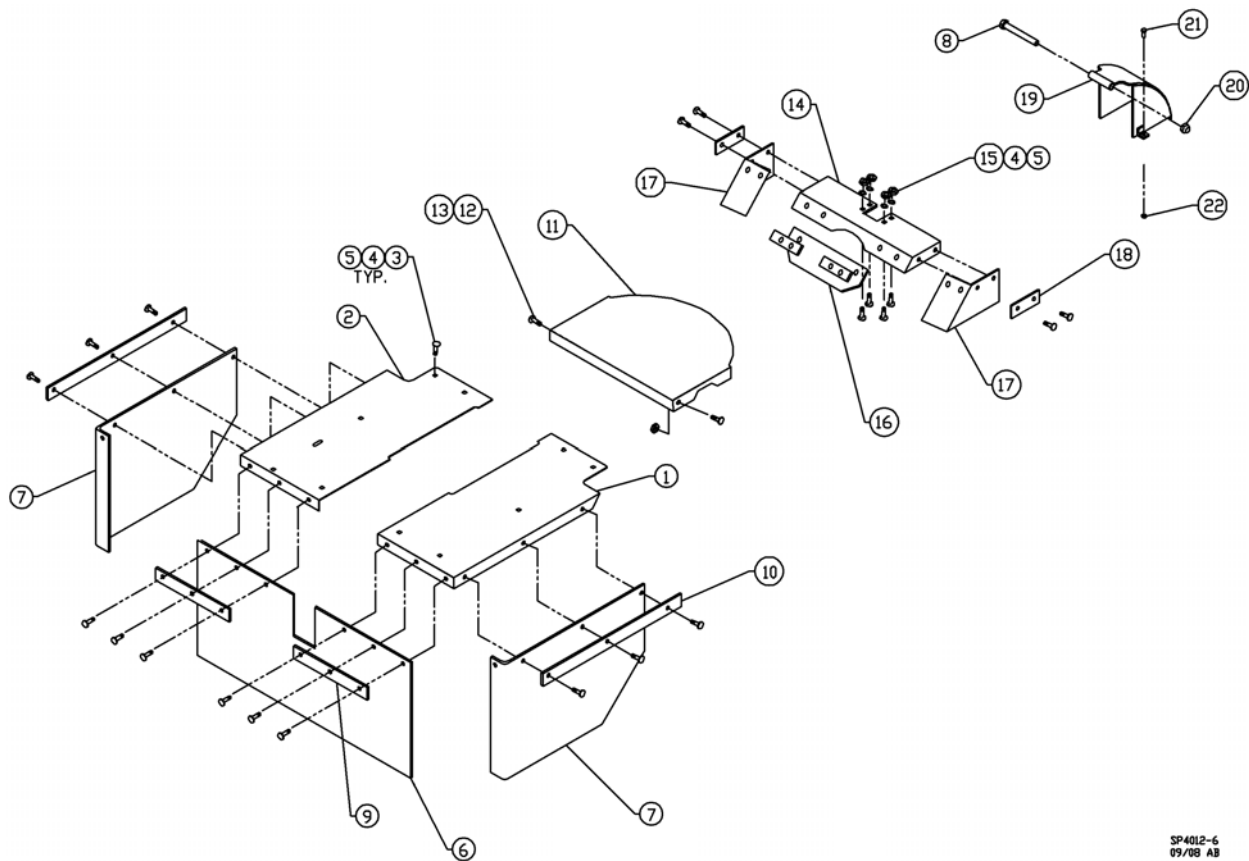

SP4012-6  
09/08 AB

MODEL	TYPE	ENGINE	HP	FUEL	CUTTING DEPTH	CUTTING HEIGHT	CUT SWING	NO. TEETH	WHEEL DIA.	WHEEL THICKNESS	TONGUE EXTENSION	WEIGHT (lbs.)
900H	Walk-Behind	Honda	13	Gas	9"	21"	N/A	12	12.25"	.5"	N/A	220
SP2000	Walk-Behind	Kohler	27	Gas	24"	27"	N/A	16	19"	.5"	N/A	695
SP4012	Self-Propelled	Kohler	27	Gas	13"	34"	40" arc	20	21"	1"	30"	1,550
	Self-Propelled	Briggs-Vanguard	35	Gas	13"	34"	40" arc	20	21"	1"	30"	1,650
	Self-Propelled	Lombardini	28.7	Diesel	13"	34"	40" arc	20	21"	1"	30"	1,650
SP7015	Self-Propelled	Deutz Turbo	60	Diesel	15"	43"	70" arc	32	26.5"	1"	N/A	3,500
SP7015TRX	Track-Mounted	Deutz Turbo	60	Diesel	15"	43"	70" arc	32	26.5"	1"	N/A	4,300
SP8018 TRX	Track-Mounted	Deutz Turbo	78	Diesel	18"	43"	80" arc	32	26.5"	1"	N/A	5,420
HURRICANE RS	Track-Mounted	John Deere Turbo	140	Diesel	25"	53"	360°	48	31"	1.5"	N/A	8,500
HURRICANE TRX	Track-Mounted	John Deere Turbo	140	Diesel	25"	72"	360°	64	36"	1.5"	N/A	12,000
	Track-Mounted	John Deere Turbo	175	Diesel	25"	72"	360°	64	36"	1.5"	N/A	12,000
	Track-Mounted	John Deere Turbo	250	Diesel	25"	72"	360°	64	36"	1.5"	N/A	12,000
3500D	Tow-Behind	Deutz Turbo	60	Diesel	15"	40"	80" arc	32	26.5"	1"	48"	2,900
7500	Tow-Behind	Deutz Turbo	78	Diesel	24"	46"	92" arc	48	31"	1.5"	60"	4,400

Call and ask about Carlton's line of Chippers or visit our website: [www.stumpcutters.com](http://www.stumpcutters.com)

**CARLTON—QUALITY PRODUCTS AND EXCEPTIONAL SERVICE**



J.P. Carlton Company Div. DAF, Inc.  
121 John Dodd Road  
Spartanburg, South Carolina 29303  
864-578-9335 • 800-243-9335 • FAX 864-578-0210

Carlton Owner's Manual
SP4012
Revised: 10/2008



**OMNEX**  
TRUSTED WIRELESS

# **JP Carlton SP4012**

**Installation / Configuration Manual**

**T151 Transmitter  
R160 Receiver**

December 21, 2005

DM-R160-0190A

Revision 2

This page is intentionally left blank.

# Table of Contents

System Overview .....	4
Features .....	4
T151 Dimensions and Controls .....	4
Installing the Receiver .....	5
Special Functions .....	6
Installation Considerations .....	6
Power the Transmitter .....	7
Test the Transmitter / Receiver Link .....	7
Download ID Code .....	8
Diagnostics—T151 Transmitter .....	10
Diagnostics—R160 Receiver .....	11
Trouble Shooting Guide .....	12
Parts & Accessories .....	16
Specifications .....	16
Warranty Information .....	16

**NOTE:** These instructions are intended only for installing and operating the remote control equipment described here. This is not a complete Operator's Manual. For complete operating instructions, please read the Operator's Manual appropriate for your particular machine.

## Safety Precautions

### READ ALL INSTRUCTIONS

**CAUTION:** Changes or modifications not expressly approved by the party responsible for compliance could void the user's authority to operate the equipment.

Failure to follow the SAFETY PRECAUTIONS may result in radio equipment failure and serious personal injury

#### Installation

PROVIDE A SAFETY CUTOFF SWITCH. If maintenance is required, the radio must be disconnected from power  
USE PROPER WIRING. Loose or frayed wires can cause system failure, intermittent operation, machine damage, etc.  
DO NOT INSTALL IN HOT AREAS. This apparatus can be damaged by heat in excess of 158° F (70° C)

#### Personal Safety

MAKE SURE MACHINERY AND SURROUNDING AREA IS CLEAR BEFORE OPERATING. Do not activate the remote system unless it is safe to do so.

TURN OFF THE RECEIVER POWER BEFORE WORKING ON MACHINERY. Always disconnect the remote system before doing any maintenance to prevent accidental operation of the machine

#### Care

KEEP DRY. Do not clean the transmitter / receiver under high pressure. If water or other liquids get inside the transmitter battery or receiver compartment, immediately dry the unit. Remove the case and let the unit air dry

CLEAN THE UNIT AFTER OPERATION. Remove any mud, dirt, concrete, etc. from the unit to prevent clogging of buttons, switches, etc. by using a damp cloth.

#### Maintenance / Welding

DISCONNECT THE RADIO RECEIVER BEFORE WELDING on this machine. Failure to disconnect will result in the destruction of the radio receiver.



## System Overview

The **ORIGA T151 / R160** is a portable, long range, programmable radio remote control system. Designed as a compact and easy-to-use product, this member of the **ORIGA** family puts complete control of your crane where it's needed most, with the operator. It's robust, easy to install and has complete self-diagnostics. This system can be a simple cable replacement or add intelligence to make it a total crane control package. It's a radio, a PLC and a valve driver all in one.

The **ORIGA T151 / R160** system uses Frequency Hopping Spread Spectrum (FHSS) technology. FHSS devices concentrate their full power into a very narrow signal that randomly hops from frequency to frequency within a designated band. This transmission pattern, along with CRC-16 error-checking techniques, enables signals to overcome interference that commonly affects licensed radios.

The **R160 receiver** is designed to be powered from a 12VDC or 24VDC system. It features 19 solid state, high-side driver input / output controls and a reliable E-Stop control.

The **T151 transmitter** comes with 4 to 7 switches. It uses standard, long lasting AA batteries. Each T151 transmitter uses a unique ID code to ensure that no two systems will conflict at a job site.

### Features

- FCC, ISC, CE approved
- License free
- 1200 foot range @ 900 MHz (900 ft. @ 2.4 GHz)
- Hand held / weatherproof / ergonomic
- Simple "wire-and-use" installation
- Resilient to impact and shock
- Available in both 900 MHz and 2.4 GHz
- Available with E-Stop for ensured operator safety
- Factory configurable for all custom applications.



R160 Receiver

T151 Transmitter

### T151 Dimensions and Controls

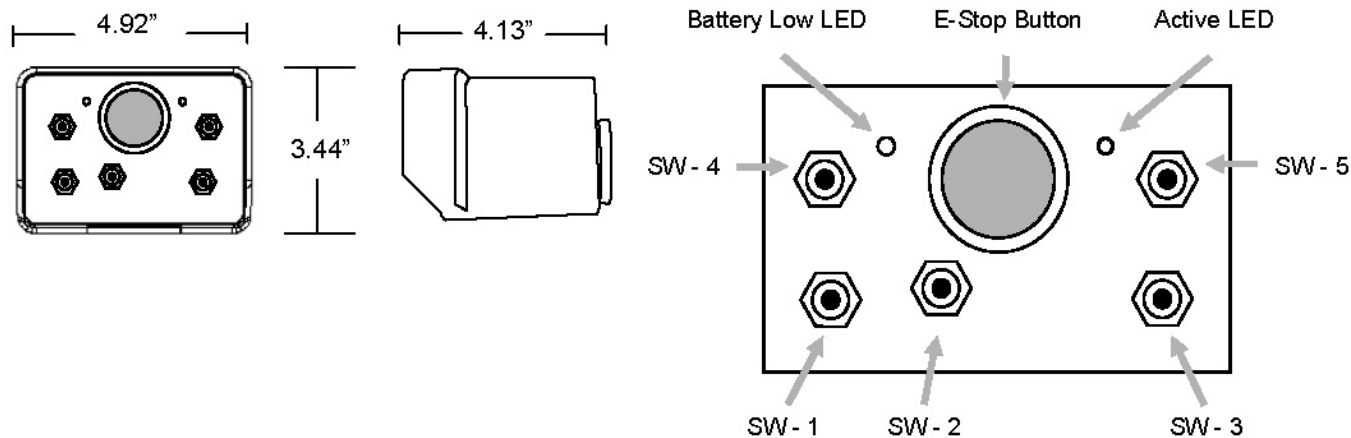

## Installing the Receiver

Use the **Wiring Diagram** and the **Connector Diagram** below to connect the receiver pins directly to the appropriate contacts of the machine electronics. R160 Output Cables can be provided with every system to simplify the wiring process. The Wire Color column below only applies to the OMNEX Output Cable configuration. Tips on mounting, power connections and filtering are also provided under **Installation Considerations**.

### Wiring Diagram

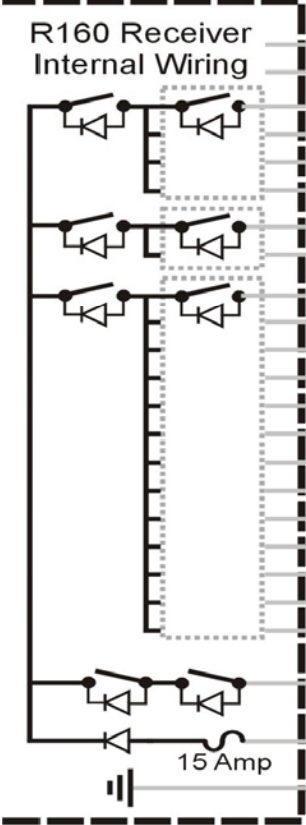

Pin-Output	Wire Colors	Functions	Notes
B7		Factory Configurable Only	
B8		Factory Configurable Only	
B12 - 19	Black/Red	Input / Output	
B11 - 18	White/Black	Input / Output	
B10 - 17	Blue/White	Input / Output	
A1 - 16	Blue/Black	Input / Output	
A2 - 15	Black/White	Input / Output	
A4 - 14	Green/Black	Input / Output	
B9 - 13	Red/White	Input / Output	
B6 - 12	Orange	Input / Output	
B5 - 11	White	Tongue Out	
B4 - 10	Green/Black/White	Tongue In	
B3 - 9	Green	Travel Reverse	
B2 - 8	Red/Black/White	Travel Forward	
B1 - 7	White/Red/Black	Gear Low	
A12 - 6	Orange/Red	Steer Left	
A10 - 5	Orange/Black	Steer Right	
A11 - 4	Blue/Red	Cutter Head Left	
A9 - 3	White/Red	Cutter Head Right	
A8 - 2	Red/Green	Cutter Head Down	
A7 - 1	Orange/Green	Cutter Head Up	
A5	Black/White/Red	Switches to Power with Link	
A6	Red	Power Input (+9V to 30VDC)	
A3	Black	Ground	

**Outputs:** 19 solid state, high-side driver outputs, 5A max. each, total combined current 15A  
**Inputs:** All output pins can be factory configured as inputs.

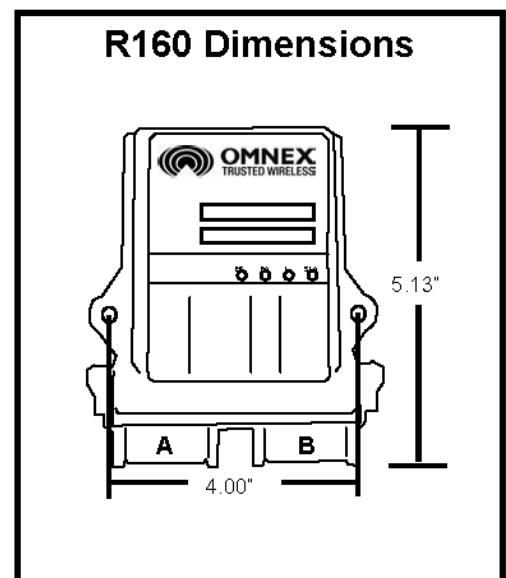
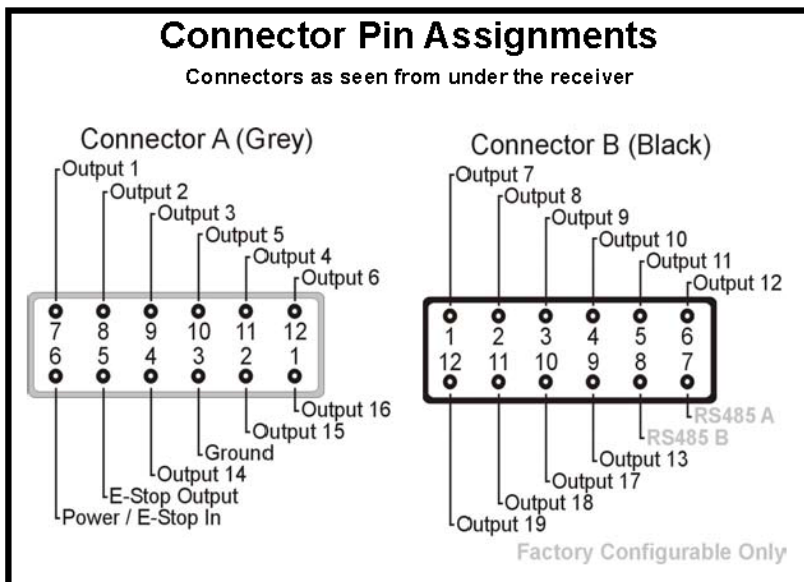

## Special Functions

*Note: The following functions are operational while the receiver has link with the transmitter. If link is not established, all receiver outputs will be unlatched (turned OFF).*

Receiver outputs controlling CUTTER (Up, Down, Right, Left), STEER (Right, Left), TRAVEL (Forward, Reverse), and TONGUE functions (In, Out) turn ON momentarily while the corresponding transmitter switches are toggled.

The receiver output controlling the GEAR (Low) function is a latching output. Once ON, it will remain ON until GEAR (High) is pressed or loss of link occurs.

Pressing E-Stop will turn off the transmitter and immediately turn OFF (unlatch) all outputs.

## Installation Considerations

### Mounting and Installation

The receiver can be mounted by fastening two ¼" bolts through the two mounting holes in the unit's enclosure. When mounting, ensure that the receiver is oriented so that the text is reading right.

**When selecting a mounting point for the receiver, it is recommended that the location require only a minimal length of wiring to connect it to the control panel, that it will be in a visible area where it has good exposure to the operator and that it is mounted on a surface that is protected from the weather and sustains minimal vibration. It is also recommended that the receiver have the best possible line of sight with the transmitter**

### Power Connections and Wiring

Whenever a power connection is made to an electronic device, it is a good practice to make both the Power (+) and Ground (-) connections directly to the Battery and avoid connecting the power from the charging side of existing wiring or making use of existing "ACC" or other peripheral connection points.

Make sure that wire of sufficient gauge and insulator type is used when connecting the outputs of the receiver to the control panel. Observe any component manufacturer's instructions and recommendations for proper integration of their product. This includes the power ratings and requirements of such components as relays, valves, solenoids, etc.

Be sure to test each of the outputs with a multi-meter prior to connecting the outputs to your end devices. This will ensure that each output has been programmed to operate in the manner required by each end device.

### Filtering and Noise Suppression

Whenever a solenoid or electromagnetic switch is controlled by the receiver, it is a good practice to install a Diode across its terminals to ensure that surges and spikes do not continue back into the circuit. Appropriate 36V Bi-directional Diodes kits can be ordered under the OMNEX part number "AKIT-2492-01".

When the receiver has been installed, install batteries into the transmitter and turn it on as explained below.

### 1. Install Batteries

Remove the battery cover on the back of the transmitter using a slotted screwdriver and insert 4 "AA" alkaline batteries. Orientation of the batteries is embossed inside the battery housing.

**NOTE:** For operation at temperatures below  $-10^{\circ}\text{C}$  to  $-40^{\circ}\text{C}$ , lithium batteries are recommended. Low temperatures reduce battery performance for both alkaline and lithium types. Refer to the battery manufacturer's specifications for detailed information on low temperature performance.



T151 Battery Housing

### 2. Turn on the Transmitter

Refer to the **Light Legend** below for diagram details.

#### 1. Press [E-Stop]

If the transmitter's (Active) light does not flash, check the battery orientation.

To turn off the transmitter, press the [E-Stop] button.

Follow these steps to ensure that there is a radio link between the transmitter and receiver.  
Refer to the **Light Legend** below for diagram details



If the receiver's (Link) light does not flash GREEN, follow the steps under **Download ID Code** below.

**The ORIGA system is now ready for use.**

## Download ID Code (Use in case of Link Test failure)

Follow these steps to download the transmitter's unique ID Code into the receiver. This will allow the receiver to establish a radio link with a specific transmitter or up to four transmitters (used individually). When downloading the first transmitters ID use step 4.1. and not 4.2.; for the remaining three transmitters use step 4.2. and not 4.1.

**NOTE:** It is necessary to download the ID Code when replacing either the transmitter or the receiver.

### 1. Opening the Receiver Case

The cap is held on by two plastic tabs at opposing sides, which can be unlatched as shown using a screwdriver. Once the cap is free, the R160 can slide open.

Use a small slotted screwdriver to press the Side Tabs inward.

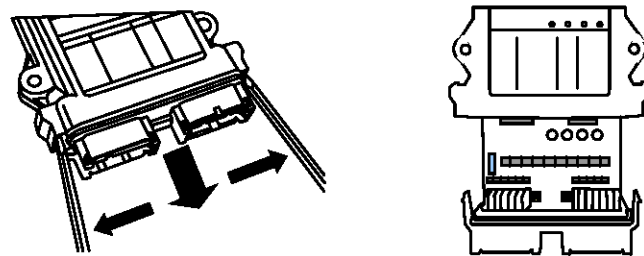

### 2. Prepare T151, Power R160

A. Press [E-Stop]

B. Twist clockwise & release [E-Stop]

C. Supply power to the receiver

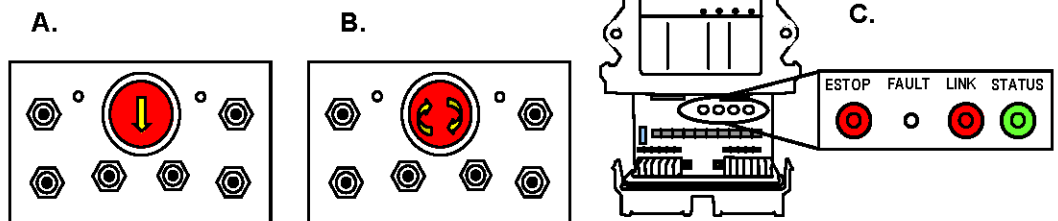

### 3. Power T151 into Configuration Mode

A. Hold [SW-5] switch UP

B. Press [E-Stop]

C. Twist clockwise & release [E-Stop]

D. Release [SW-5] Switch

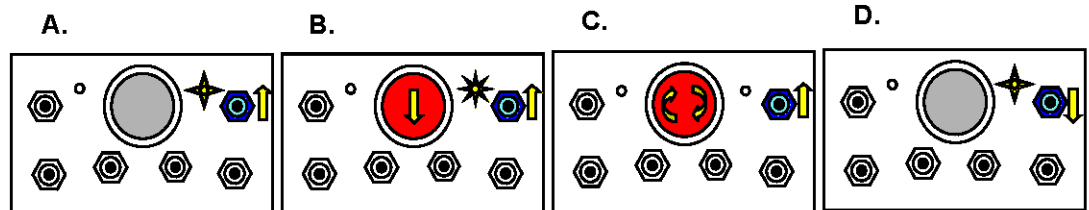

## Download ID Code (Con't)

### 4.1. Put Receiver into Setup Mode for Primary ID

- A. Press & hold [Setup] button until (Status) light goes from slow flash to fast flash
- B. Release [Setup] button. (Status) light goes to solid GREEN, (Link) light turns off

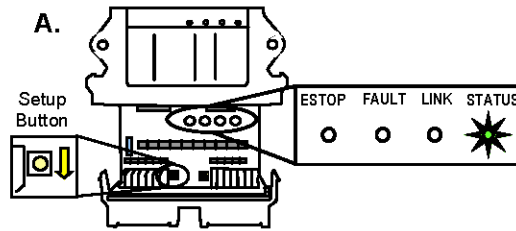

**NOTE 1:** Programming the Primary ID will clear all other ID's already programmed into the receiver.

**NOTE 2:** If left idle in Setup Mode for over 30 seconds, the receiver will time out. The (Link) light and (Status) light will flash RED rapidly. To return to Setup Mode, repeat step 4.

OR

### 4.2. Put Receiver into Setup Mode for Secondary ID's

- A. Press & hold [Setup] button until (Status) light goes from slow flash to fast flash to medium flash (approx. 10 Sec.)
- B. Release [Setup] button. (Status) light goes to solid GREEN, (Link) light turns off

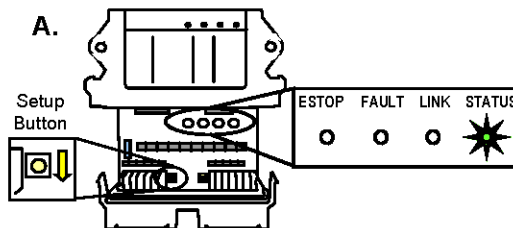

**NOTE 1:** The Receiver will hold up to 4 Transmitter ID's. When the 5th Transmitter ID is downloaded, it's ID will replace the ID of the least recently used transmitter (i.e. The receiver will retain the ID's of the three transmitters that have been most recently linked).

**NOTE 2:** If left idle in Setup Mode for over 30 seconds, the receiver will time out. The (Link) light and (Status) light will flash RED rapidly. To return to Setup Mode, repeat step 4.

## 5. Download ID Code

- A. Press [SW-5] switch UP
- B. (Link) light goes to GREEN. Once complete, (Link) light goes to RED as the transmitter turns off

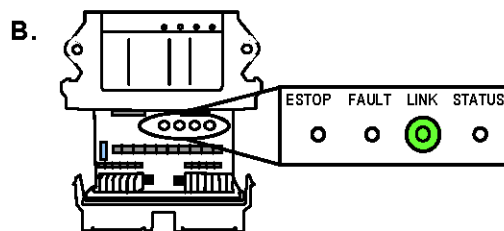
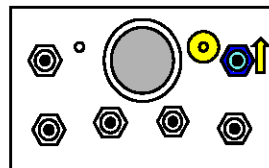

**NOTE:** When replacing the receiver cover, ensure the cover snaps completely into place to create a weather proof seal around the base of the receiver.

## 6. For multiple ID Downloading

- A. Repeat steps 3-5, **using step 4.2. instead of 4.1.** for all remaining Transmitters. Then check the link of all Transmitters one at a time by following the instructions on page 7, Test the Transmitter/Receiver Link.

## Diagnostics—T151 Transmitter

	Low battery. Unit will run approximately 10 hours after Battery light starts flashing.
	Flashing rapidly for 10 seconds indicates a transmitter failure.
	<b>Normal Operation</b> The Active light will flash several times per second, indicating that the transmitter is sending signals to the receiver. The Active light will remain on momentarily whenever a function changes
	<b>On Power Up</b> Release the E-Stop button within 10 seconds to power up the transmitter, or the unit will power down.
	<b>Normal Operation</b> The transmitter is in Download Mode.
	<b>On Power Up</b> Press and release the E-Stop button within 10 seconds to power up the transmitter, or the unit will power down.
	Stuck switch detected. Ensure that all switches are in a centered position. The transmitter will not power up when a function is ON.
	<b>On Power Down</b> Unit is still powered. Check for stuck switches, as the transmitter will not power down when a function is ON. Alternating flash means that the transmitter is in Calibration Mode.

<b>Light Legend</b>	Solid	Slow Flash	Fast Flash	Red Light	Green Light	Yellow Light	Alternating Red & Green Light
---------------------	-------	------------	------------	-----------	-------------	--------------	-------------------------------



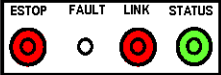
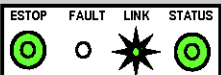
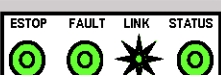
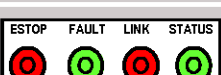

# Diagnostics - R160 Receiver

## Normal Operation

	Transmitter is OFF If the transmitter is off, the receiver is operating properly.
	Transmitter is ON When the transmitter is turned on, the Link light (fast flashing) and E-Stop (GREEN) indicates the receiver is operating properly
	Transmitter is in Operation When a function is activated on the transmitter, the Fault light will turn on GREEN. This indicates the receiver is operating properly
	Transmitter is OFF When a latched function is activated then the transmitter is turned off, the Fault light will stay on GREEN. If the system was intentionally designed this way, the receiver is operating properly, if not call for service.

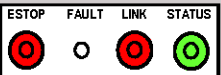
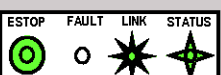
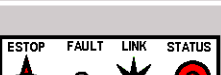
## Trouble Indicators

*Note: In some cases, the indicator lights will be different depending on whether the transmitter is on or off. Please note the transmitter status in the "Description" column for each case.*

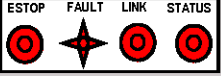
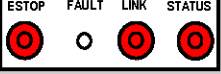
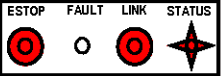
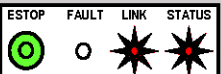
Indicator Lights	Description	Solution
	Transmitter is ON The reason is the transmitter is not communicating with the receiver.	Refer to <b>Trouble Shooting Chart #3</b> for solutions
	Transmitter is ON A low battery condition has been detected.	To detect intermittent conditions caused by poor or corroded ground or power circuits, the GREEN light will continue to flash for 30 seconds after the condition has been removed.
	Transmitter is ON An internal fault with the E-Stop has been detected.	Inspect E-Stop wiring for short circuit. Disconnect E-Stop wire as close to the receiver output as possible. If the Status light changes to: <ul style="list-style-type: none"> <li>• GREEN, a short occurs after disconnection point.</li> <li>• Stays flashing RED, send it in for service .</li> </ul>
	Transmitter is ON A short to ground or excessive current draw on an output. It is most likely caused by a wiring fault.	Ensure transmitter is functioning properly, check status of each output connection: Press each function button and observe Fault Light. <ul style="list-style-type: none"> <li>• If GREEN, everything is OK.</li> <li>• If RED, there is a short in that connection.</li> </ul>
	Transmitter is ON The E-Stop output has been connected with one of the other outputs	Follow the wire and check for connections with other wires, disconnect to see if condition clears. If not, call for service.
	Transmitter is OFF A wiring short to the battery has been detected.	Refer to <b>Trouble Shooting Chart #1</b> for solutions
	Transmitter is OFF The receiver has detected an internal fault.	Refer to <b>Trouble Shooting Chart #1</b> for solutions
	Transmitter is OFF Blown fuse detected.	Refer to <b>Page 8</b> for instructions on how to open the receiver case to access fuse. Check wiring for shorts or bare spots. If fuses continue to blow, call for service.
	Transmitter is ON A setup failure has occurred.	Either hold the Setup button for 5 seconds to return to Setup mode or cycle power to return to the normal operating mode.
	Transmitter is OFF The receiver is powered incorrectly.	Most likely cause of this condition is that an output wire or the E-Stop wire has been connected to the power supply while the power wire is disconnected from the power supply.

Light Legend	Solid	Slow Flash	Fast Flash	Red Light	Green Light	Yellow Light	Alternating Red & Green Light
							



Test the Receiver—R160

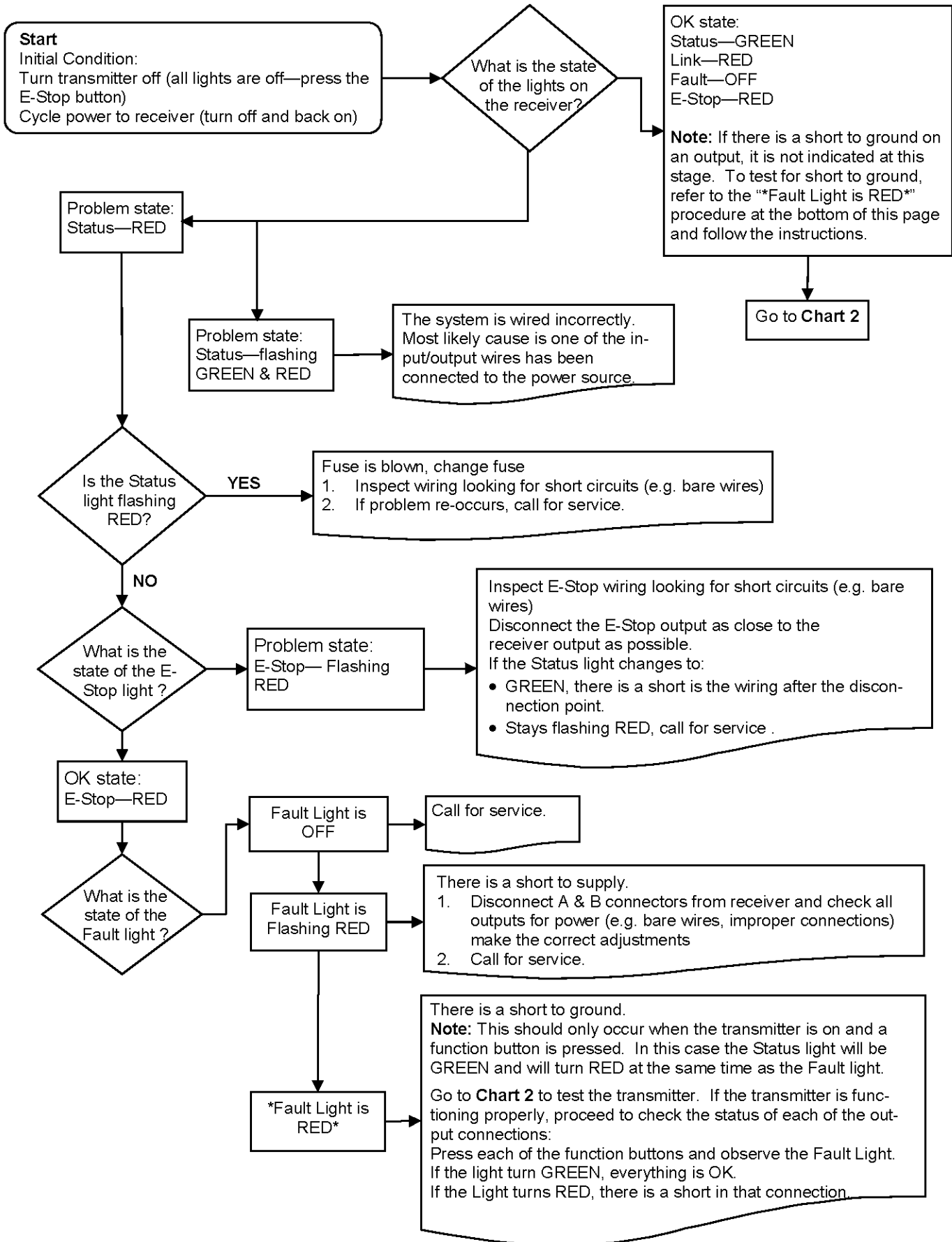

Test the Transmitter—T151

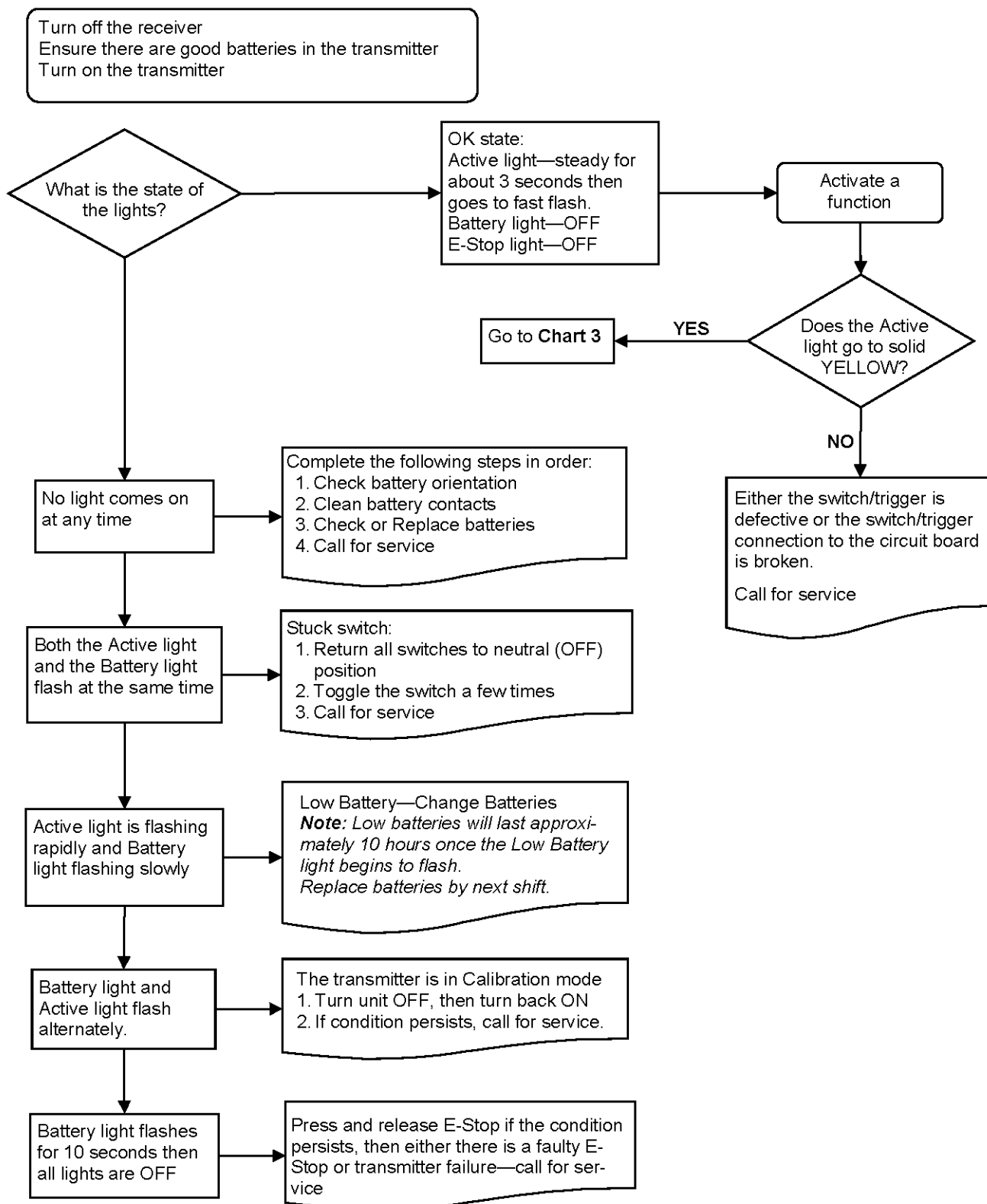

Testing the Transmitter / Receiver Communication

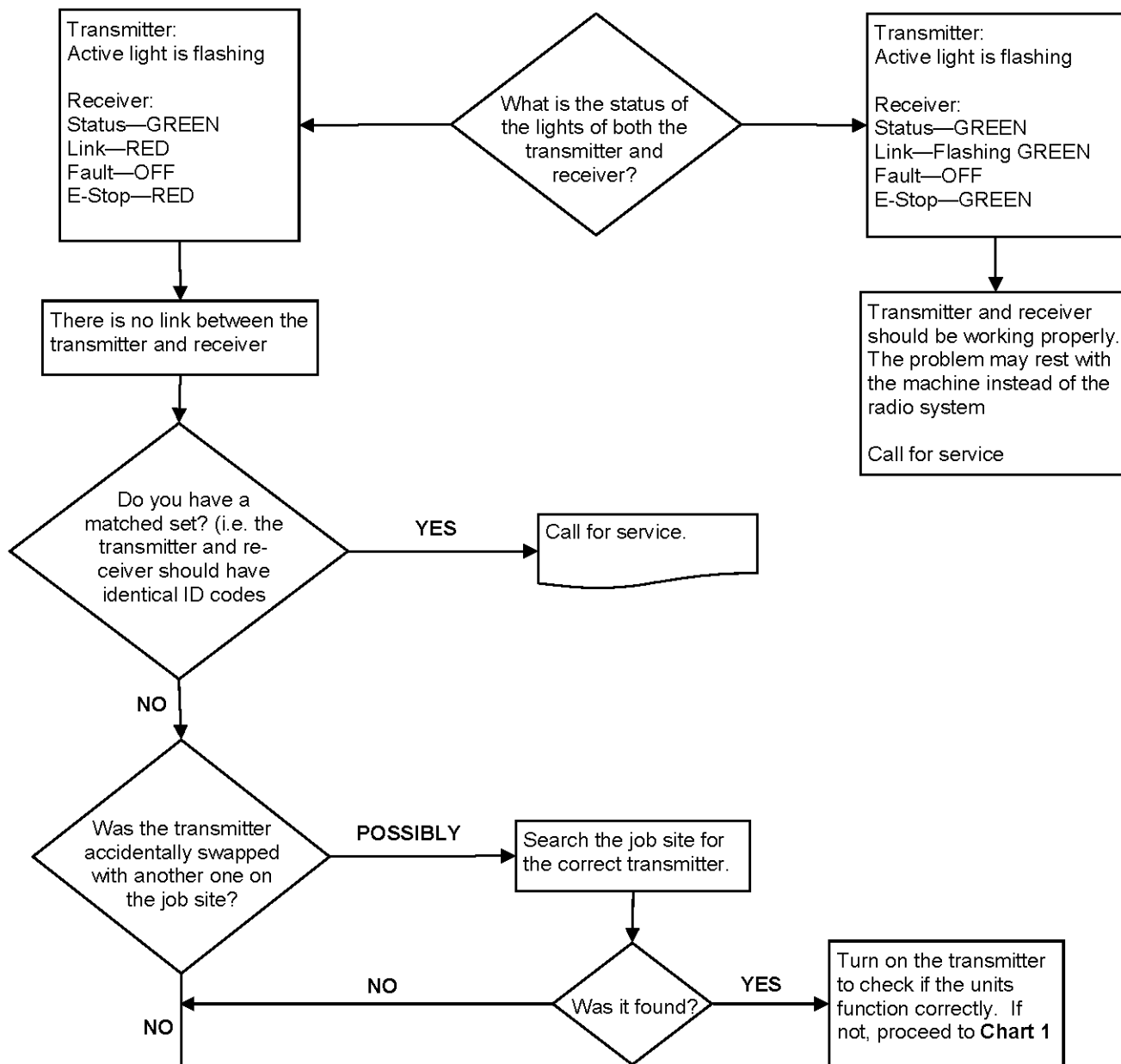

**!!Caution!!**

**Note:** Before you proceed with the Download ID procedure located on **Page 8**, great care and caution must be adhered to. Also, refer to **Chart #4** for Tips and Considerations.

If by accident, the transmitters have been switched with another unit, by downloading the ID code to a new receiver, it is possible for the transmitter to operate 2 units at the same time (if the original receiver unit is still on the job site). Therefore it must be certain that the transmitter / receiver pair are the correct set.

Secondly, once the download procedure is completed, ensure all other units on the job site are stopped. Test the operation of the newly configured set to ensure no other machines on the site work with the same transmitter.

Once you are certain that the transmitter / receiver pair are a unique set, continue normal operations.

## Considerations when Downloading the ID

### Potential downloading issues

If testing of the receiver and transmitter both show the system as working (Chart 1 & 2), then the transmitter and receiver will both go into Download/Configuration mode.

Possible issues could arise during Step 4, the download phase of reprogramming. In this case there are 2 symptoms to look for:

1. The Link light on the receiver will not turn GREEN when the power switch is toggled on the transmitter to download
2. The receiver will “time out” indicating that it didn’t receive a signal from the transmitter within the 30 seconds from the time the receiver was put into Setup Mode.

If all indications appear normal during the download phase, test the link by turning on the transmitter (note: the transmitter shuts off after transmitting the ID code in Step 4)

1. If the Link light on the receiver doesn’t turn GREEN, the receiver didn’t receive all of the information that was sent from the transmitter.

### Possible Solutions

1. Try the Downloading steps again
2. If this doesn’t correct the problem, send both the transmitter and receiver in for service.

***Note:** you could try to determine whether the fault lies with the transmitter or receiver by completing the downloading procedure with a different transmitter. If this step works, then the fault lies with the original transmitter. If not, the fault may lie with the receiver.*

### !!Caution!!

**Note:** Before attempting downloading with another transmitter, understand that reprogramming the receiver with another transmitter, could result in two receivers on the job site responding to the one transmitter. If the original transmitter was sent in for repair, Disconnect the receiver (disconnect connector A) to continue using the machine without remote capability and without fear of inadvertently operating the machine with the other transmitter.

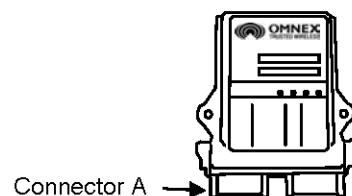

### Reprogramming Tips:

1. Use a pointy instrument to depress the Setup button on the receiver (i.e. a pen) as the button is relatively small
2. Follow each step as laid out in the procedure
3. Never lay the receiver circuit board down on anything metallic (there are contact points on the back which could contact the metal and damage the receiver)

## Parts & Accessories

Part	Part Number	Description
Batteries	B0010	4 x AA alkaline
R160 Output Cables	ACAB-2493-01	Generic Output Cable- see illustration
Toggle Switch	AKIT-1504-04	Honeywell 1TL1-7
E-Stop Button	AKIT-1821-02	RAFIX16, 25mm, C&K 1.30074.2810300 See illustration
Magnet Back	AKIT-2498-02	see illustration
Bipolar Diode Kit	AKIT-2492-01	36V, Bi-directional, Motorols P6KE36CA
Fuse	F0039	Bussman ATC-15
Socket Connectors	J0418	Grey, 12-pin, Deutsch DTM06-12SA
Socket Connectors	J0419	Black, 12-pin, Deutsch DTM06-12SB
	J0420	12 pos., Deutsch WM12S
Pin	J0417	Female, Size 20, Deutsch 0462-201-20141
Sealing Plug	J0421	Size 20, Deutsch 0413-204-2005
R160 Connector Kit	AKIT-2337-01	Includes Deutsch socket connectors, wedges, pins and sealing plugs.



R160 Output Cable



E-Stop



Magnet Back

## Specifications

	R160 Receiver	T151 Transmitter
Size	5.1" x 4.7" x 1.4" (130mm x 119mm x 36mm)	3.44" x 4.9" x 4.13" (87mm x 124mm x 105mm)
Weight	0.65lbs (0.295kg)	1.8lbs (0.817kg)
Construction	High impact plastic, weatherproof	High impact, low temperature plastic, weatherproof
Input Power	+9V to 30VDC	4AA alkaline batteries
Battery Life	N/A	>120 hours (continuous use)
Operating Temperature Range	-40F to 158F (-40C to 70C)	-40F to 158F (-40C to 70C)
Outputs	3A (max) each (sourcing), 10A (max) each (combined)	N/A
Antenna	Internal	Internal
Approvals	USA- FCC part 15.247 Canada- ISC RSS 2210 Europe- EN 440 Australia- C-Tick	

### FCC Rules and Compliance

This device complies with Part 15 of the FCC Rules. Operation is subject to the following two conditions: (1) This device may not cause harmful interference, and (2) this device must accept any interference received, including interference that may cause undesired operation.

FCC Part 15.247  
ISC RSS 210

### Warranty

OMNEX Control Systems Inc. warrants to the original purchaser that the OMNEX products are free from defects in materials and workmanship under normal use and service for a period of ONE YEAR, parts (EXCLUDING: SWITCHES, CRYSTALS, OR PARTS SUBJECT TO UNAUTHORIZED REPAIR OR MODIFICATION) and labor from the date of delivery as evidenced by a copy of the receipt. OMNEX's entire liability and your exclusive remedy shall be, at OMNEX's option, either the (a) repair or (b) replacement of the OMNEX product which is returned within the warranty period to OMNEX freight collect by the OMNEX APPROVED carrier with a copy of the purchase receipt and with the return authorization of OMNEX. If failure has resulted from accident, abuse or misapplication, OMNEX shall have no responsibility to repair or replace the product under warranty. In no event shall OMNEX be responsible for incidental or consequential damage caused by defects in its products, whether such damage occurs or is discovered before or after replacement or repair and whether or not such damage is caused by the negligence of OMNEX Control Systems Inc.

**OMNEX Control Systems Inc.**