

# Models And Specifications

### Mark One Globe Valve

The Mark One is designed for most gas and liquid applications. The valve's unique construction handles pressures from vacuum to 15,000 psi (1034 Bar) and temperatures from -423° to 1500° F (-253° to 816° C).

The Mark One uses a spring cylinder actuator for stiffness, high positioning accuracy, repeatability, controlled high speed, and instant response. Because the cylinder is rated up to 150 psi (10.3 Bar) air supply, the actuator has the thrust necessary to shutoff against high fluid pressures. [Note: 150 psi (10.3 Bar) is rated for sizes 25, 50 and 100 cylinders; others may be rated at lower pressures.] The spring, the air supply pressure, the fluid pressure itself, and a self-aligning seat ring all contribute to exceptionally tight shutoff.

Most common maintenance and operational problems with globe valves can be traced to cage-guiding, where the plug head is guided in a metal cage. The close metal-to-metal contact between the cage and plug often results in galling and sticking. However, the Mark One is designed with double-top stem guiding that is out of the flow stream. Its heavy-duty design eliminates contact between the plug and seat retainer (or cage), thus galling and sticking are eliminated.

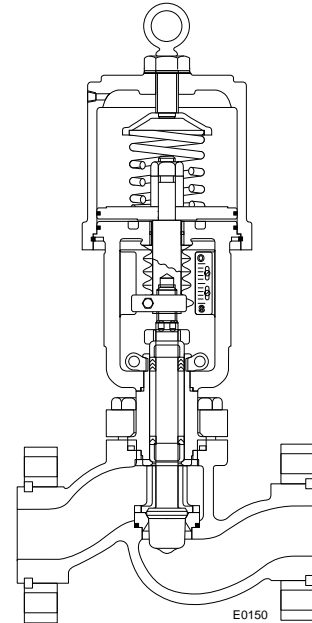

**Figure 2-1: Mark One**

**Table 2-1: Mark One Body Specifications**

Sizes	1/2 – 48 inch: class 150 thru 600 1 – 24 inch: class 900 thru 2500 1 – 12 inch: class 4500
Forms	Globe, angle, 3-way, Y-body, expanded outlet, sweep angle, offset
End Connections	Separable flange, integral flange, NPT, socketweld, buttweld, Grayloc, RTJ
Body Materials	Carbon and stainless steels, chrome-moly, alloy 20, Hastelloy B, Hastelloy C, Monel, nickel, titanium, bronze, other castable materials
Bonnet Types	Standard, extended, special extended, cold box, metal bellows seal
Trim	Equal percentage, linear or quick-open flow characteristics; pressure-balanced, hard facing and soft seats available

**Table 2-2: Linear Actuator Specifications**

Types	Double-acting cylinder with fail-safe spring action; diaphragm; manual handwheel; hydraulic
Sizes	Cylinder: 25, 50, 100, 200, 300, 400, 500, 600, 1000; diaphragm: 80; manual handwheel: 9, 12, 18, and 24-inch diameters; hydraulic: 2 1/2, 3 1/4 and 5-inch bores
Action	Air-to-open, air-to-close (field reversible); lock in last position
Maximum Supply Pressure	Cylinder: 150 psig (10.3 Bar); Some limitations apply – see Section 22
Auxiliary Handwheels	Side- and top-mounted continuously-connected; top-mounted push only
Positioners	Beta positioner with pneumatic module for 3-15, 3-9, 9-15 psi (0-1, 0-0.6, 0.6-1 Bar) input signal, additional and split range models available); Beta positioners with electro-pneumatic module for 4-20 and 10-50 mA input signal

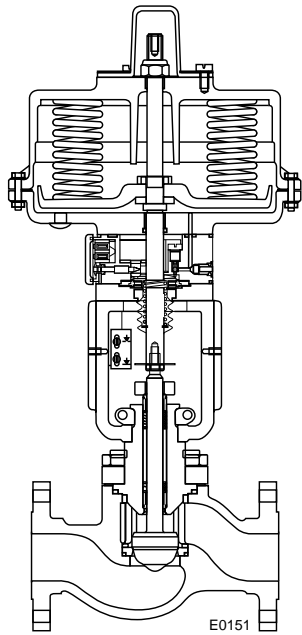

**Figure 2-2: Trooper**

### Trooper Globe Valve

The Valtek Trooper valve is a high performance general service control valve with a high thrust diaphragm actuator. It is designed for use in ANSI Class 150 or 300 service applications with temperatures ranging from -20° to 650° F (-30° to 345° C).

In addition to its high thrust, the reversible actuator is compact. An optional integral I/P or P/P positioner ensures high positioning accuracy proportional to the valve instrument signal. The integrally mounted positioner eliminates external tubing requirements, reduces pinch points and keeps moving parts safe from external dirt and damage. Reversing actuator does not require positioner or tubing changes, extra parts, etc.

The actuator accepts air supply pressures up to 60 psig (4 Barg) which allows the valve to shutoff against high pressure drops. Different spring sets are available to meet individual application requirements. Removing the reversible actuator from the valve is easy with Valtek's unique yoke design and yoke clamps.

Many of Valtek's standard Mark One valve features are included in the Trooper general service valve, including: heavy-duty, stem guides; self-centering, clamped-in seat ring; raised face integral flanges; multiple trim reductions and easy top-entry valve accessibility.

The Trooper valve is available in 1, 1½, 2, 3, 4-inch valve sizes and with carbon steel or stainless steel bodies. Valve sizes 1 thru 2-inch are also available in socketweld or NPT end connections.

**Table 2-3: Trooper Body Specifications**

Sizes	1, 1½, 2, 3 and 4-inch, ANSI Class 150 and 300
Form	Globe
Materials	Carbon and stainless steel
End Conn.	Integral flange; NPT or socketweld for 1 thru 2-inch only
Trim	Equal percentage or linear available in 316 Stainless Steel, 316 with TFE seat, 316 with stellite, 416 heat-treated
Packing	Teflon, AFP, SafeGuard and SureGuard
Bonnet Types	Standard and Purge with twin packing
Flow	Flow-under with air-to-open or air-to-close fail direction

**Table 2-4: Diaphragm Actuator Specifications**

Sizes	Diaphragm area: 31 and 77.5 in <sup>2</sup> (200 and 500 cm <sup>2</sup> )
Action	Air-to-open, air-to-close, reversible
Supply Pressure	20 - 60 psig (1.4 - 4 Barg)
Positioners	Optional integral I/P or P/P positioner with 4-20 mA or 3-15 psig (0-1 Barg) input signal
Spring Set Range (psig)	3-15, 4-13, 7-16, 13-27, 14-31, 20-43, 25-54
Material	Actuator Cases – Aluminum Diaphragms – CR w/ polyimide fabric
Accessories	Top-mounted handwheel, 3-way solenoid valve, Position Pac, External I/P (explosion proof), filter regulator

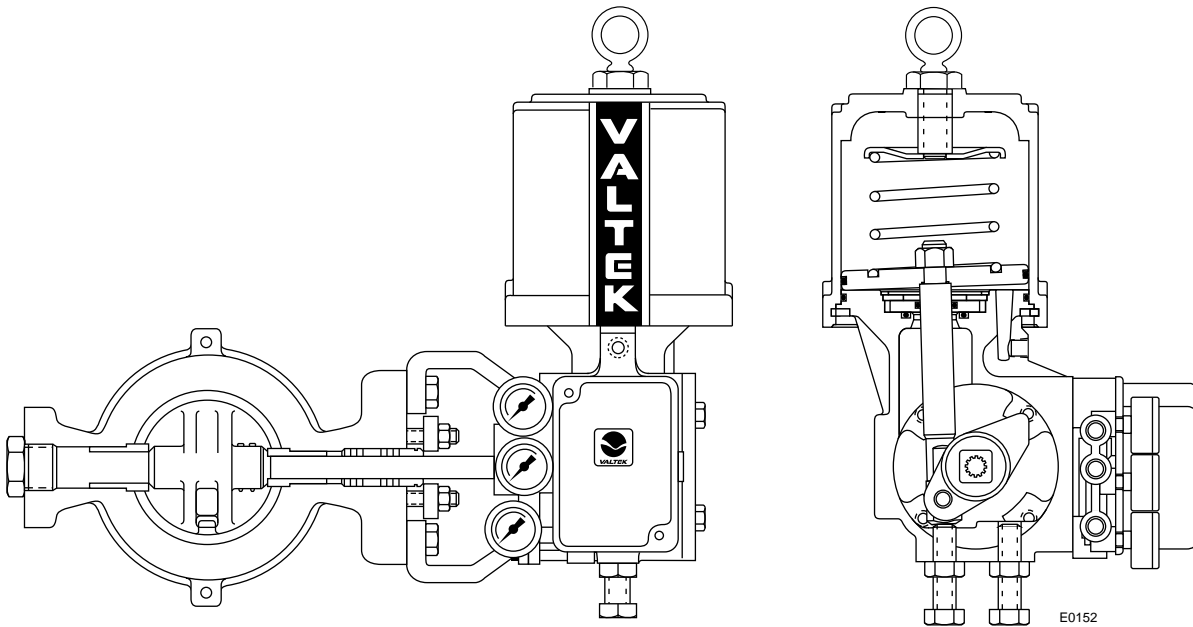

**Figure 2-3: Valdisk**

### Valdisk Rotary Valve

Valdisk is a lightweight rotary-style control valve designed with an eccentric and cammed disk that provides high capacity, tight-shutting, high-performance service. It performs at pressures from vacuum to 1000 psi, and temperatures from -423° to 1200° F (-253° to 650° C).

Valdisk's wafer-style body permits easy handling. A short face-to-face dimension permits shorter flange bolts. (Long bolts increase the chance of leakage during external fires.) Each body has a disk stop to prevent

over-stroking and damage to the seat and to identify disc position after line installation. The disk pulls away from the seat immediately upon opening, permitting better throttling and minimizing seat wear.

The rotary-motion cylinder actuator is similar to the linear-motion actuator on the Mark One. Many parts are interchangeable between the two designs, such as the cylinder and O-rings. The actuator is attached to the shaft by a single pivot point, minimizing lost motion.

**Table 2-5: Valdisk Body Specifications**

Sizes	2 – 36 inch
Ratings	ANSI Class 150 – 2500
Style	In-line wafer
Materials	Carbon and stainless steels, chrome-moly, alloy 20, Hastelloy B, Hastelloy C, Monel, nickel, titanium, bronze, other castable materials
Seat Forms	Soft seat, metal seat, soft seat with metal back-up
Disc Characteristics	Modified equal percent (inherent), linear (easily characterizable with positioner cam)
Stand. & Opt. Class of Disc	2 – 12 inch: class 150, 300 14 – 30 inch: class 150
Shaft Materials	17 – 4 PH, Nitronic 50, Inconel, Monel, Hastelloy C

**NOTE:** Valtek also manufactures Valdisk valves for high pressure or high temperature applications.

**Table 2-6: Rotary Actuator Specifications**

Types	Double-acting cylinder with fail-safe spring action; Toggle-link cylinder, electric, hydraulic, electro-hydraulic
Sizes	Cylinder sizes: 25, 50, 100 and 200
Action	Air-to-open, air-to-close, fail-in-place (field reversible)
Max. Supply Pressure	150 psig (10.3 Barg) for sizes 25, 50 and 100. 80 psig (5.5 Barg) size 200 actuator only (Some limitations apply-see Section 16)
Auxiliary Handwheels, Handlevers	Declutchable; manual gear-operated; 12-inch handlever (sizes 1 thru 6-inch) 18-inch handlever (sizes 8 and 10-in.)
Positioners	Beta and Model 80R pneumatic positioners; Beta I/P and Model 80R electro-pneumatic positioners (See Table 2-2 for input signals.)

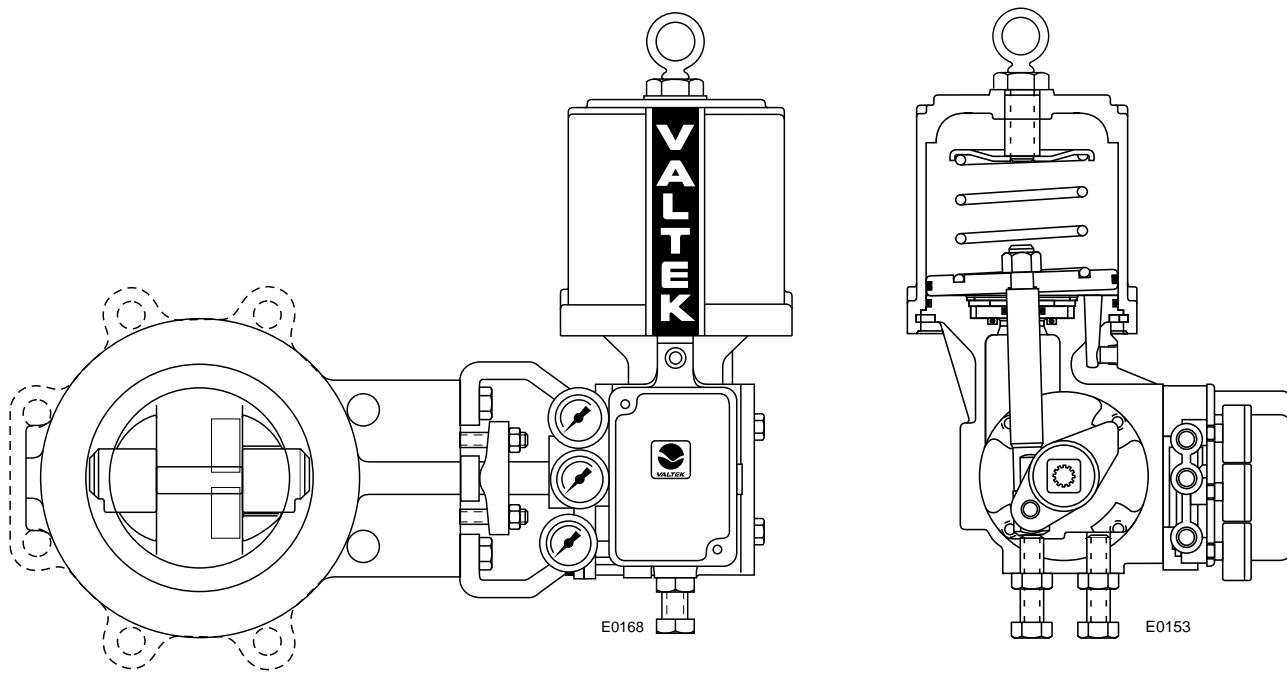

**Figure 2-4: Valdisk 150**

### Valdisk 150 Rotary Valve

The Valdisk 150 high-performance rotary valve is designed to control ANSI Class 150 processes. It is available in a wafer or lug-style body providing tight shutoff at a low cost with quick delivery schedules.

The Valdisk 150 rotary valve is available in size 2 thru 36-inches with an operating temperature range of -100° to 400° F (75° to 205° C).

**Table 2-7: Valdisk 150 Body Specifications**

Sizes (inches)	2 – 36-inch
Body Forms	Wafer, lug
Body Rating	ANSI Class 150
Shutoff Rating	ANSI Class VI
Operating Temperature	-100° to 400° F (-73° to 204° C); -20° F (-29° C) for carbon steel
Fire Seat Rating	API 607
Actuator Types	Pneumatic (sq.in.): 25, 50, 100, 200; electro-pneumatic; manual (see rotary actuator specifications, page 8)
Positioner Signals	Pneumatic: 3-15, 3-9, 9-15 psig (0-1, 0-0.6 and 0.6-1 Barg), additional range and split-range models available; electro-pneumatic: 4-20, 10-50mA

The typical liquid pressure recovery factor ( $F_L$ ) of the Valdisk 150 rotary valve is better than most butterfly valves, reducing the tendency to cavitate or choke.

The Valdisk 150 has an eccentric-cammed disc that rotates out of the seat upon opening. This double-offset disc design reduces seat wear and leakage and allows a low breakout torque requirement.

A floating self-centering seat is held in place by an internal seat retainer that increases sealing capacity as it aligns with the disc.

**Table 2-8: Materials of Construction**

Body, disc, retainer	Carbon steel, stainless steel, Alloy 20, Hastelloy C, Inconel, Monel, nickel
Shaft	17-4 PH (std.), stainless steel, Alloy 20, Hastelloy C, Inconel, Monel, Nitronic 50
Bearing	Ryload (rolled stainless steel with Teflon insert)
Packing	Teflon V-ring (std.), Grafoil, SafeGuard, SureGuard
Seat	Teflon energized with Viton O-ring

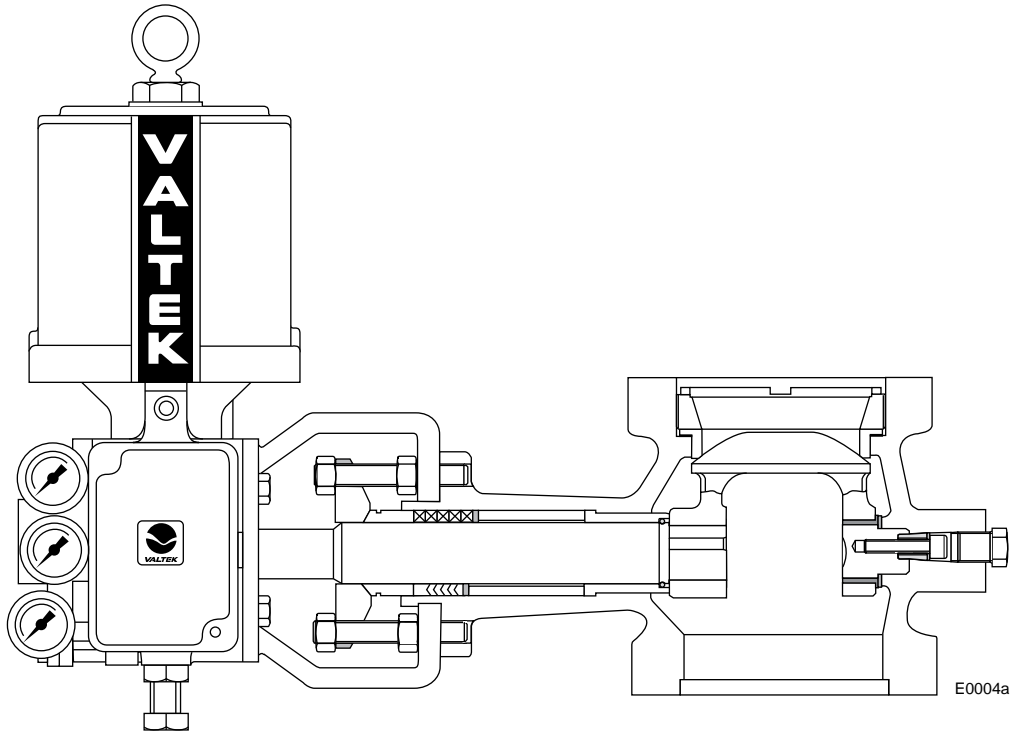

**Figure 2-5: MaxFlo**

### MaxFlo Rotary Plug Valve

The MaxFlo is a high performance rotary control valve using an eccentric plug which provides high rangeability, zero breakout torque and durable trim with a significant increase in valve life.

Designed for use in a wide variety of applications ranging from petrochemical to low content slurry and pulp service to severe service, the MaxFlo can handle pressure drops up to 1450 psig (100 Barg). Operation temperatures can range from -150° F to 800° F (-100° C to 430° C).

The eccentric plug provides rangeability greater than 100:1, compared to 50:1 for typical globe valves and 20:1 for most butterfly valves. The shutoff rating reaches Class IV for metal seats and Class VI for soft seats. NACE certification is also available.

MaxFlo will fail either open or closed in the event of air or signal loss. Flow with the shaft upstream for fail-closed and shaft downstream for fail-open.

A high thrust cylinder actuator and eccentric plug allow high flow capacities in rugged applications giving Valtek's MaxFlo rotary control valve the advantage.

**Table 2-9: MaxFlo Body Specifications**

Type	Eccentric rotary plug
Sizes	1 – 12-inch
Ratings	ANSI Class 150, 300, 600
Body Materials	Stainless steel, carbon steel
Ends	Flanged, flangeless
Plug Materials	17-4 (std.), 316L with Stellite overlay
Seal Materials	17-4 (std.), 316L with Stellite overlay PTFE (soft)
Packing Materials	Teflon V-ring, Braided TFE/Kevlar, Grafoil, SafeGuard, SureGuard
Actuators	High thrust cylinder sizes 25, 50 100, 200-square inch and manual
Positioner	Beta positioner with pneumatic or electro-pneumatic module

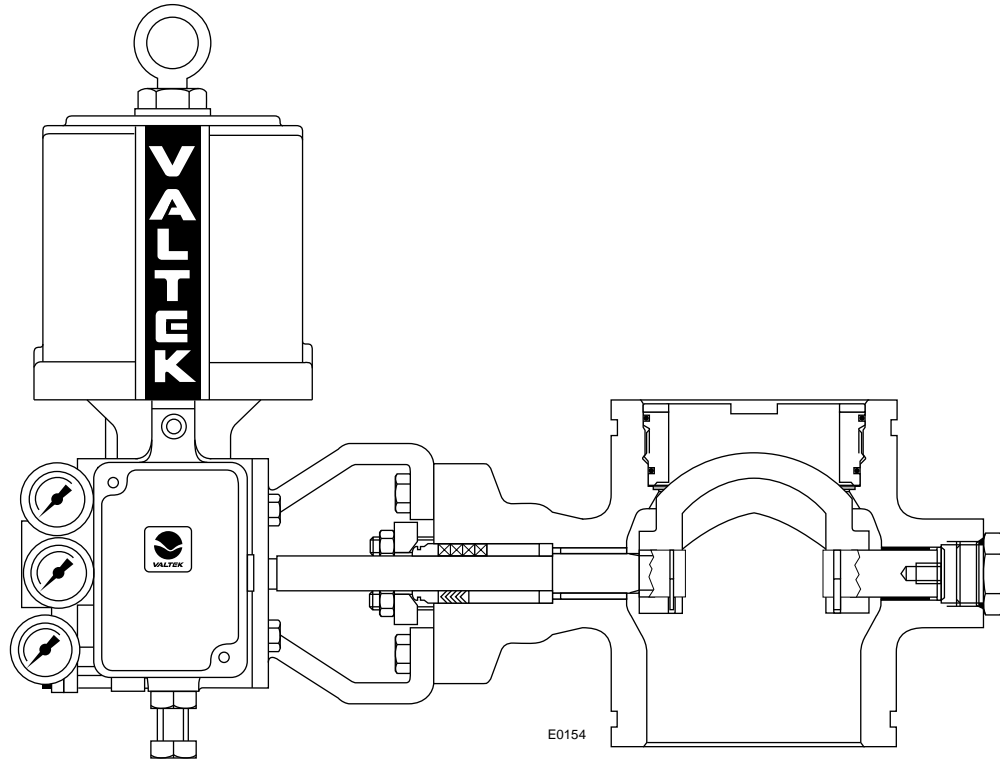

**Figure 2-6: ShearStream**

### ShearStream Ball Valve

The Valtek ShearStream ball valve features a segmented V-notch ball to reduce clogging, to improve shearing action and to exceed 300:1 rangeability. The one-piece body provides high performance by preventing piping forces from altering the seat tightness (as is the case with two-piece bodies).

ShearStream's bi-directional Flex-loc™ seal is pressure-assisted to provide better than ANSI Class IV shutoff with a metal seal and bubble-tight shutoff with a soft seal. A flow ring is also available for throttling applications with Class II leakage. The self-centering seal improves shutoff, allows for easier installation and requires no shims.

ShearStream maintenance is easy. The seal can be replaced without removing the ball and shaft. The shaft is also serviceable from the outboard end of the valve.

The body features a full, uninterrupted gasket surface for improved gasket alignment. The actuator and packing box are completely interchangeable with the Valdиск rotary valve.

**Table 2-10:  
ShearStream Body Specifications**

Sizes	1 – 16 inch
Ratings	ANSI Class 150, 300, 600: 1, 1½, 2, 3, 4, 6, 8, 12-inch; ANSI Class 150, 300: 10, 16-inch
Style	In-line ball
End Connections	Flangeless (standard), separable flange, integral flange
Body Materials	316 stainless steel, carbon steel, other materials as required
Ball Materials	317 stainless steel with hard chrome plating, Stellite faced
Shaft Materials	17-4 PH, Nitronic 50
Seal Forms	Bi-directional Flex-loc metal seal, soft seal, flow ring
Characteristic	Equal percentage, linear
Ball Rotation (to open)	Counterclockwise (as viewed from the actuator)
Actuator	Refer to Valdиск

## Severe Service Valves

Valtek has engineered several special trims to handle high pressure drop service. The trims are designed to eliminate cavitation, reduce high noise levels and handle flashing applications often associated with high pressure drop service.

The ChannelStream cartridge uses specially designed channels and intersecting holes (plenums) in series to prevent single point, large pressure recovery which can cause cavitation and hydrodynamic noise.

For less serious cavitation applications, Valtek offers a CavControl retainer that minimizes cavitation damage by controlling the location of imploding vapor bubbles.

The MegaStream attenuator reduces gaseous noise levels up to 15 dBA with staged pressure reduction through a series of drilled-hole cylinders.

Tiger-Tooth stacks effectively reduce gaseous and hydrodynamic noise levels up to 30 dBA and eliminate the damaging effects of cavitation in liquids.

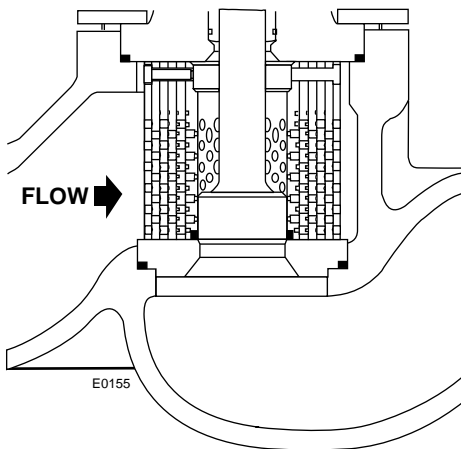

**Figure 2-7: ChannelStream**

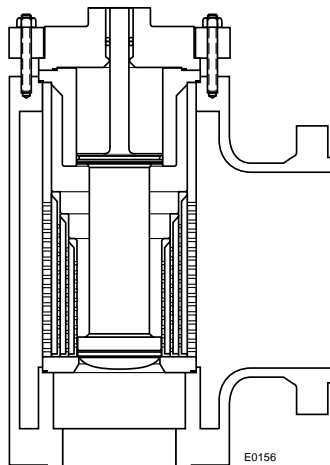

**Figure 2-8: MegaStream**

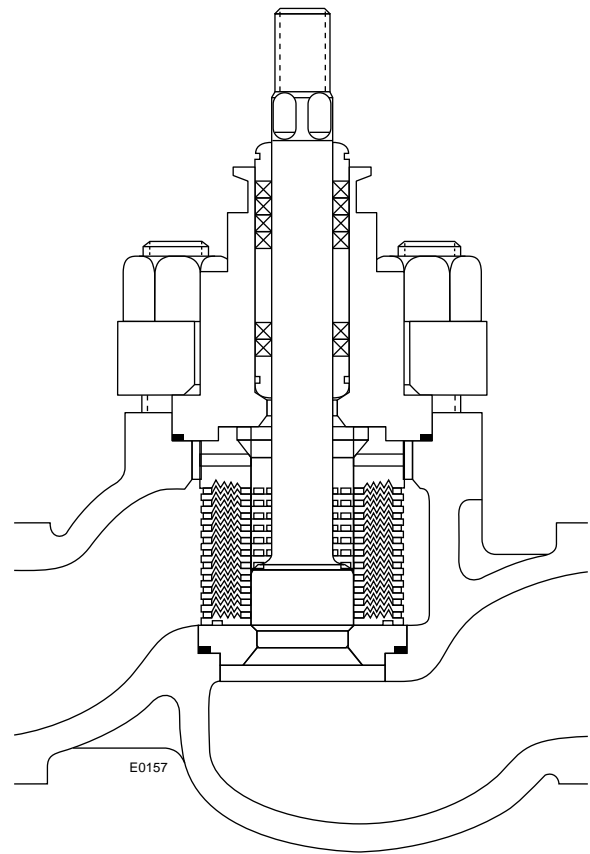

**Figure 2-9: Tiger-Tooth**

**Table 2-11:  
Severe Service Valve Specifications**

Sizes	1 – 42 inch thru ANSI Class 600 1 – 24 inch thru ANSI Class 2500 1 – 12 inch thru ANSI Class 4500
Forms	Globe, angle, Y-body, expanded outlet, fabricated angle
Body Material	Carbon and stainless steels, chrome-moly, alloy 20, Hastelloy B, Hastelloy C, Monel, nickel, titanium, bronze, other castable materials
Trim	Liquid Applications: ChannelStream cartridge, CavControl retainer, Tiger-Tooth; Gas Applications: MegaStream attenuator, Tiger-Tooth
Linear Actuators	Refer to Table 2-2.

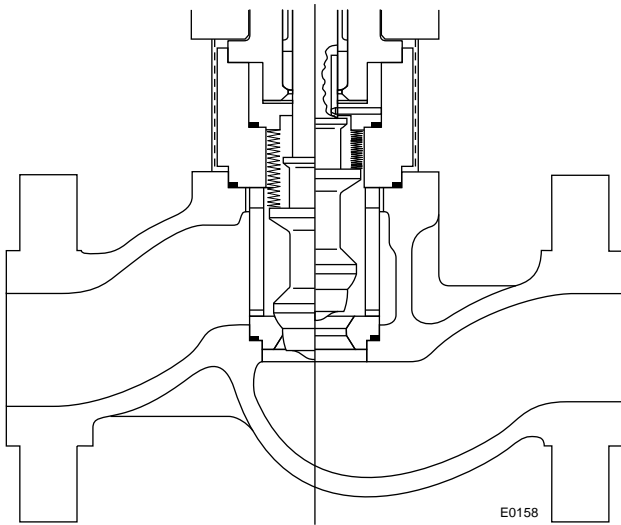

**Figure 2-10: Guardian**

**Guardian Metal Bellows Seal**

The Guardian Metal Bellows Seal control valve is designed for those services that require zero leakage. The compact guardian metal bellows seal assembly can be installed in Valtek's Mark One globe valves and handle temperatures up to 650° F (343° C) and pressures to 400 psi (27.6 Bar). The typical cycle life for Valtek's basic design when throttling between 25 and 75 percent open is 200,000 cycles. The bellows is in a relaxed state at 50 percent open. This reduces stress during throttling. An anti-rotation pin prevents accidental rotation of the plug and bellows housing which will cause bellows failure.

**Guardian II Metal Bellows Seal**

The Guardian II metal bellows seal valve is the most recent designed valve that allows no fugitive emissions. The Guardian II uses a formed metal bellows design with minimal welded joints and has a full-cycle life of up to 5 million cycles. This formed metal bellows seal assembly can be installed in Valtek's Mark One globe valves. It is reliable in hazardous processes ranging from -320° to 1000° F (-196° to 538° C) and pressures to 1100 psig (76 Barg).

A metal shroud envelopes the bellows acting as a pressure boundary in service, allowing use of a single, pressurized gasket seal and preventing fluid contact with the bellows housing during normal operation. External pressurization of the bellows increases cycle life and the maximum allowable pressure, while eliminating "bellows squirm." The replaceable plug head allows trim changes without changing the bellows assembly. The bellows is relaxed with the plug seated.

Each bellows assembly is helium leak tested. Additionally, a tell-tale tape located in the bellows housing may be monitored visually, electronically or by pressure, allowing fast detection of bellows failure.

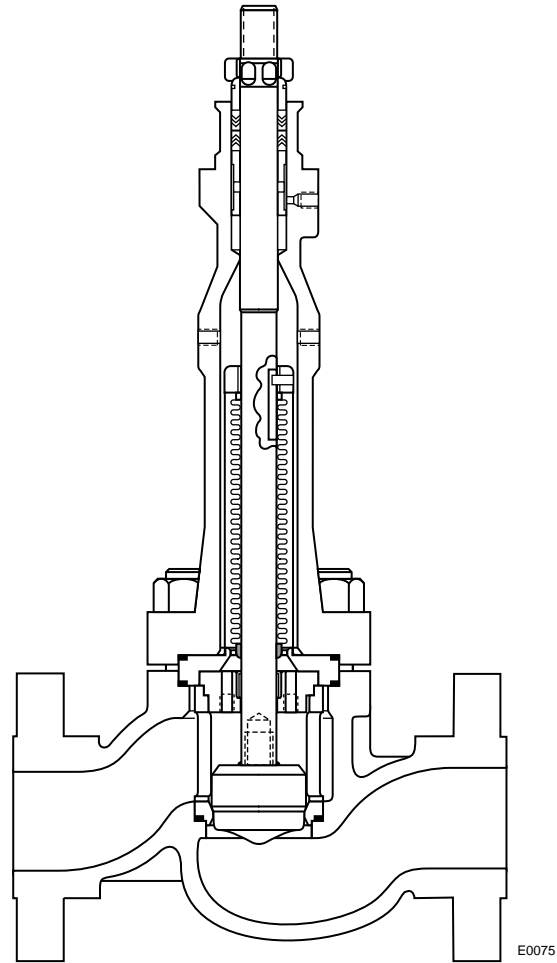
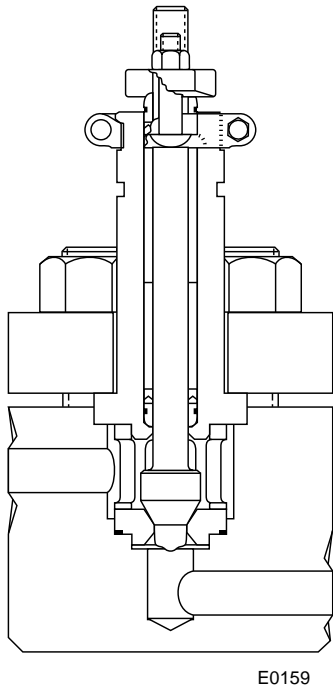

**Figure 2-11: Guardian II**

**Table 2-12: Guardian II Body Specifications**

Sizes	½, ¾, 1, 1½, 2, 3, 4, 6, 8
Forms	Globe, angle, expanded outlet
Characteristics	Equal percentage, linear, quick-open
Bellows Material	Inconel 625 (std.), Hastelloy C- 22, other materials
Bonnet	One-piece including bellows housing
Packing	Double set
Packing Material	Teflon V-ring, glass-filled Teflon, asbestos-free packing w/Inconel wire, Grafoil, others as required
Gasket Types	Flat: Teflon, Kel-F Spiral wound: stainless steel / Grafoil
Guides	Glass-loaded Teflon, Grafoil, bronze, Stellite

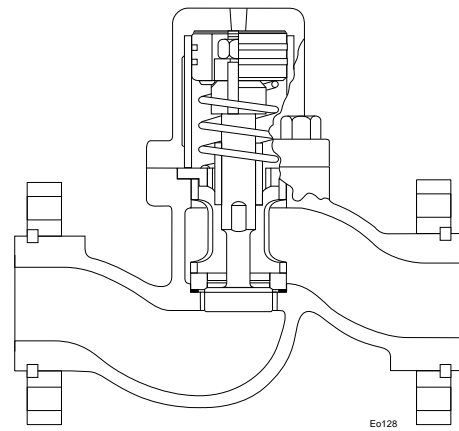



**Figure 2-12: Mark Two Offset with Butt-weld Ends**

**Mark Two**

Fabricated from barstock, the Mark Two can be machined in high pressure classes and/or special alloys where fast delivery is required. Many parts are interchangeable with the Mark One. Available in sizes 1/2 thru 6-inch and ratings to ANSI Class 4500, the Mark Two has four major body styles: in-line, angle, offset, and three-way. The offset and angle configurations are the most economical to produce. Because of difficult machining angles, the in-line configuration is the least economical to manufacture.



**Figure 2-13: Mark Three**

**Mark Three**

The Mark Three is a line operated on/off valve. Upstream pressure is directed through an electrically operated solenoid. When energized, the solenoid allows upstream line pressure to open the valve. The steel producing industry uses this valve for steam injection during coke oven cleaning, soot blowing. It is available in standard Mark One sizes.

**Tek-Check**

Used extensively in the oil and gas industry, Valtek's piston check valve features a non-slaming piston which is effective in dampening pulsating flow. The Tek-Check has a clamped-in seat and top-entry design for easy maintenance. The body and seat ring are interchangeable with the standard Mark One. It is available in sizes 1 thru 36-inch, and in ratings through ANSI Class 2500.

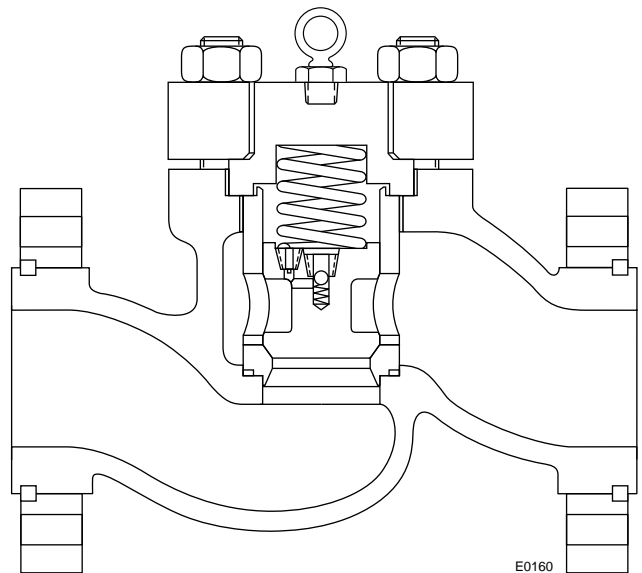

**Figure 2-14: Tek-Check Non-Slam Piston**

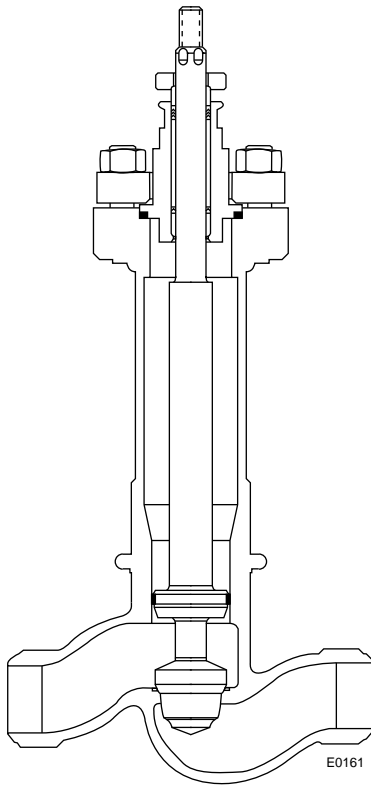

**Figure 2-15: Mark Six**

### Mark Six

Installed in cold box-style cryogenic applications down to  $-452^{\circ}\text{F}$  ( $-269^{\circ}\text{C}$ ), the Mark Six provides easy maintenance from outside the cold box. It is constructed from bronze or austenitic stainless steel for maximum impact strength at low temperatures. To minimize heat transfer into the cold box, the body is constructed with a lightweight, fabricated extension which is designed to keep an insulating vapor barrier between the liquified gas and the packing box. The standard Mark Six is available in sizes 1 thru 10-inch and in ratings through ANSI Class 600. Special high pressure Mark Six pressure designs are also available.

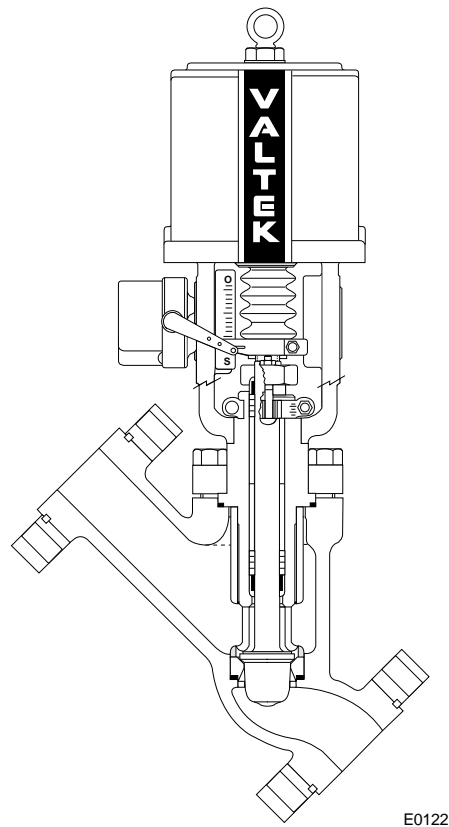

**Figure 2-16: Eight**

### Mark Eight

The unique "Y" body design of the Mark Eight allows a higher flow capacity per given size than a conventional globe valve. Because of the nearly straight-through flow, the valve generates less pressure drop through the valve than a conventional globe valve. All parts are interchangeable with the Mark One except the body, retainer, bonnet and plug. Mark Eight is available in sizes 1 thru 18-inch and through ANSI Class 2500.

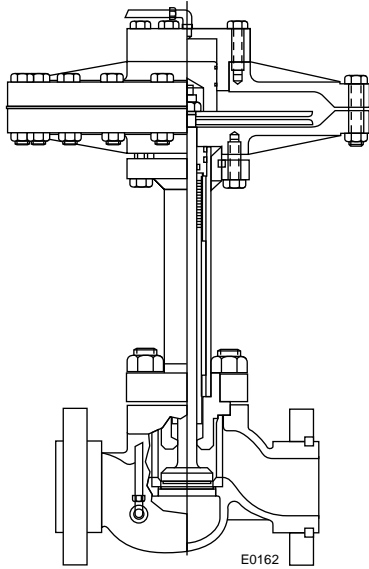

**Figure 17: DeltaStream**

**DeltaStream**

The DeltaStream is a pressure-balanced regulator used primarily by the aerospace industry in high temperature gas applications. Upstream pressure is delivered to a small piston within the diaphragm actuator. (This piston has the same area as the plug.) Downstream pressure is delivered to the top of the diaphragm. A separate pneumatic signal is sent to the bottom of the diaphragm. As the downstream pressure decreases the pressure in the top of the actuator decreases and the valve opens allowing the downstream pressure to increase. It is available in 3 and 4-inch sizes, Class 150 through 600.

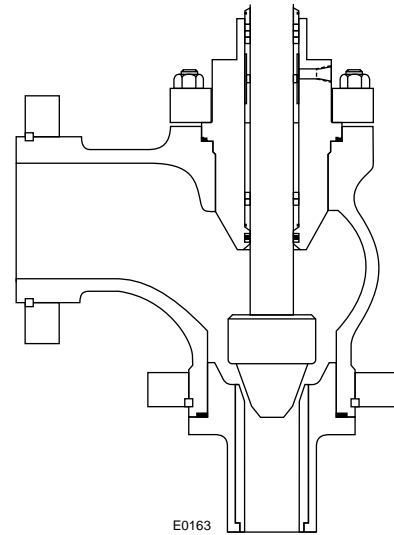

**Figure 19: Survivor**

**Survivor**

A globe style valve with a sweep angle body, the Survivor is used in slurry applications where erosion would cause damage in standard valves. There is no conventional seat retainer, instead, the seat is retained from the bottom of the valve. A large gallery reduces the velocities in the valve body alleviating erosion. It is currently available in Sizes 1 through 14-inch. The Survivor has also been used with special ceramic trim for high pressure slurry letdown in mining operations.

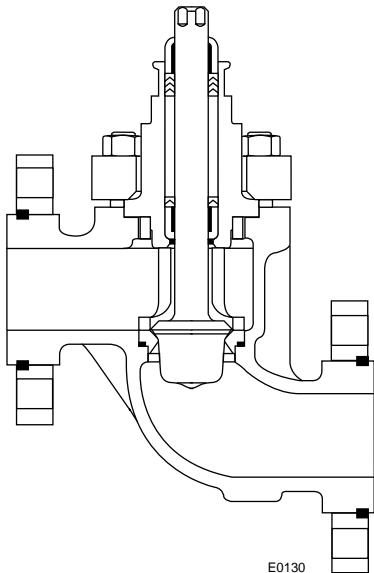

**Figure 18: Mark Eleven**

**Mark Eleven**

The Mark Eleven is designed for installation in offset piping configurations. All parts, except the body, are identical to the Mark One.

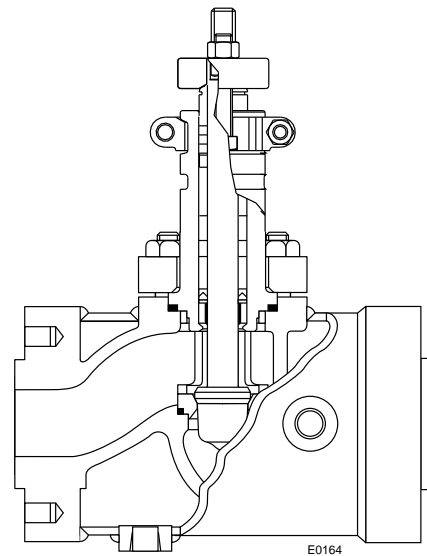

**Figure 20: Steam Jacketed**

**Steam Jacketed**

Steam jacketed valves use standard Mark One globe valves with oversize, blind flanges for a full jacket or standard flanges for a partial jacket. The jacket is rated for 150 psi (10.3 Bar) and is equipped with a 3/4-inch NPT supply and drain connection.

## Nuclear-grade Valves

Valtek is ASME authorized to produce Class I, II and III nuclear grade valves and spare parts. Valtek's quality assurance capabilities include maintaining complete material traceability of component parts and testing.

## Downstream Devices

Valtek provides a wide variety of economical downstream, noise reduction devices. Often, one of these noise reduction devices in series with a Mark One, MegaStream, ChannelStream or Tiger-Tooth control valve can be selected to attenuate noise to within the acceptable sound pressure level (SPL) required while reducing noise attenuation costs. The capabilities of these devices are as follows:

MegaStream plates and diffusers for SPL reductions up to 15 dBA.

Tiger-Tooth downstream attenuators for SPL reductions up to 30 dBA.

In-line silencers for venting applications or for SPL reductions beyond 25 dBA.

The following describes the construction and operation of these devices:

### MegaStream Plate

Installed between raised face flanges immediately downstream from the valve, the MegaStream plate incorporates a series of stages to control line turbulence and absorb the pressure drop. The number of stages varies according to the application. It is available in sizes 1½ thru 42-inch and is constructed from carbon or stainless steels (other materials are available upon request).

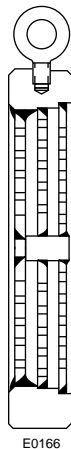

Figure 2-21: MegaStream Plate

### MegaStream Diffuser

MegaStream diffusers share the high pressure drop with the valve. By design the length of the diffuser and the number of holes vary to accommodate the flow capacity required. Available designs include standard diffuser, standard diffuser with outer shell, and a vent diffuser. Sizes include 1 thru 42-inch, in either carbon or stainless steel.

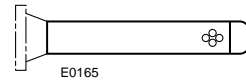

Figure 2-22: MegaStream Diffuser

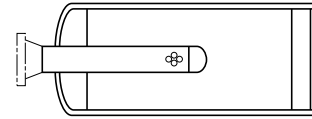

Figure 2-23: MegaStream Diffuser with Vent Diffuser

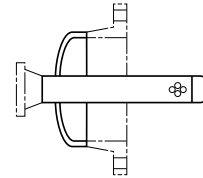

Figure 2-24: MegaStream Diffuser with Outer Shell

## Tiger-Tooth Vent Element

With the vent element, flow is directed across a series of Tiger-Tooth discs, each of which has a series of concentric grooves (or teeth) machined into the face. This allows a series of expansions and contractions to occur, permitting the pressure drop to occur gradually. The discs are clamped in place by the housing and can easily be disassembled. Vent elements are available in sizes 1½ thru 42-inch.

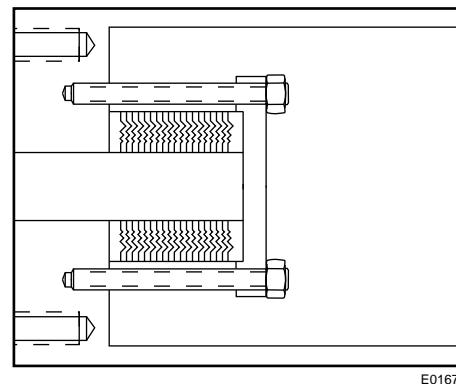

Figure 2-25: Tiger-Tooth Vent Element

## Special Testing

With an in-house engineering flow lab, Valtek is capable of performing specialized valve tests, such as: noise, cavitation, seat leak, cryogenic, high temperature, life cycle, corrosion, stroke, seismic static deflection, nozzle loading, modal analysis, vibration, metal analyzing and verification, and mass spectrometer leak measurement. If necessary, other special tests can also be performed.