



FAIRBANKS NIJHUIS™

MODELS D5430, D5730, D2430,
M, MT, MV, MVS, W, WD

**SUBMERSIBLE
SOLIDS HANDLING PUMPS**

INSTALLATION, OPERATION AND MAINTENANCE MANUAL

NOTE! To the installer: Please make sure you provide this manual to the owner of the equipment or to the responsible party who maintains the system.

PUMP/MOTOR IDENTIFICATION

Carefully record all of the following data from your pump/motor nameplate. It will aid in obtaining the correct replacement parts for your pump. In addition to the nameplate, the pump serial number is also stamped on the discharge flange.

Pump:

Serial Number _____

Size _____ Model # _____

GPM _____ Head _____ (feet)

BHP: _____ RPM: _____

Pump Weight _____ (lbs.) _____

Motor:

Horsepower _____

Serial Number _____

Motor Frame _____

Full Load Speed _____

Full Load Amps _____

Phase/Hz/Volts _____ / _____ / _____

Motor Weight _____

Motor Identification Number _____

Date Placed in Service _____

D5430, D5730, D2430 M, MT, MV, MVS, W, WD Submersible Solids Handling Pumps

Installation, Operation and Maintenance

TABLE OF CONTENTS

PUMP/MOTOR IDENTIFICATION	2	ASSEMBLY DRAWINGS	
WARRANTY HIGHLIGHTS	4	D5430MT Pull-Up thru 365 Frame	39
LOSS OR DAMAGE IN TRANSIT	4	D5430MT Pull-Up thru 365 Frame Larger Elbow	40
WARRANTY KC685 (5-Year) (03/93)	5	D5430MT Pull-Up, 400/440/490 Frame	41
WARRANTY KC885 (15-Month) (03/93)	6	D5430MT Pull-Up, 400/440/490 Frame Larger Elbow	42
WARRANTY KC985 (9-Month) (03/93)	7	D5430MV Pull-Up thru 365 Frame	43
INTRODUCTION	8	D5430MV Pull-Up thru 365 Frame Larger Elbow	44
PRE-START UP & START-UP CHECKLIST	9	D5430MV Pull-Up 400/440/490 Frame	45
SAFETY	10	D5430MV Pull-Up 400/440/490 Frame Larger Elbow	46
STORAGE OF PUMPS	11	D5430MVS Straight Thru Discharge Pull-Up	47
GENERAL	12	D5430W	48
		D5430WD	49
INSTALLATION		D5430CWD	50
General	13	D5731MV Pull-Up, 12"	51
Piping	13	D5731MV Centerline Pull-Up, 14" and 16"	52
5430, 5730, 2430 MT or MV	14	D5733MV 14" Centerline Pull-Up	53
5430, 5730, 2430 W	17	D5731MV Centerline Pull-Up, 18" and 20"	54
5430, 5730, 2430 WD	19	D5731MVS 12" C/L Pull-Up, Straight Thru Discharge	55
OPERATION		D5731MVS 14" Centerline Pull-Up, Straight Thru Discharge	56
General	23	D5731W 12" thru 24"	57
Duty Cycles	23	D5731WD Dry Pit Submersible 12" thru 24"	58
Starting the Pump	25	D5731CWD Dry Pit Submersible 12", 14" and 16" Combination Base Elbow	59
Stopping the Pump	26	D2436M Pull-Up	60
Seasonal Operating Instructions	26	D2430MV Centerline Pull-Up	61
Emergency Procedures	26	D2430W 12" and 16"	62
		D2430WD 12" and 16"	63
TROUBLESHOOTING	27	PARTS LIST	64
MAINTENANCE		MOTOR DRAWINGS	
General	28	210 and 220 Frame	65
Pump Disassembly	28	250 Frame	66
Motor Disassembly	29	250 Frame, Jacketed	67
Motor Assembly	30	320/360/365 Frame	68
Pump Assembly	31	320/360/365 Frame, Jacketed	69
Wear Rings	33	400/440/445/490 Frame	70
Maintenance History	34	400/440/445/490 Frame, Jacketed	71
Maintenance Notes	31	SUBMERSIBLE MOTORS MATERIAL SPECIFICATIONS	72
REPAIR PARTS		AUXILIARY DIAGRAMS	73
Ordering Parts	36	OPTIONAL SURE PICK LIFTING SYSTEM	82
Returning Parts	36		
SERVICE			
Warranty Service	36		
Service After Warranty	36		
TECHNICAL DATA	37		

WARRANTY HIGHLIGHTS

- 1) Seller warrants products of its own manufacture against defects in materials and workmanship under normal use and service for: five (5) years, prorated, from date of shipment for permanent Public Works installations; 15 months, prorated, for permanent Industrial installations; and 9 months for portable Construction/Mining installations.
- 2) Accessories and components not manufactured by seller are warranted only to the extent of the original manufacturer's warranty.
- 3) No allowances will be made for repairs or alterations effected without specific written authorization from Seller.
- 4) The equipment as manufactured by Fairbanks Nijhuis™ is precision machinery. Proper care can give a lifetime of satisfactory service. Warranties of performance are based on the use of original equipment manufactured (OEM) replacement parts. Fairbanks Nijhuis shall assume no responsibility when alterations, nonauthorized design modifications and/or non-OEM replacement parts are incorporated.
- 5) This warranty is VOID unless the purchaser provides protective storage, installs and maintains the equipment in accordance with manufacturer's instructions.
- 6) Under the terms of this warranty, Seller shall not be responsible nor liable for:
 - a) Consequential, collateral or special losses or damages.
 - b) Equipment conditions caused by fair wear and tear, abnormal conditions of use, accident, neglect, or misuse of said equipment.
 - c) In-shop labor charges after the first 12 months from installation.
 - d) Loss or damage resulting from supplying of defective part(s) or improper repairs by unauthorized person(s).
 - e) Damage caused by abrasive materials, chemicals, scale deposits, corrosion, lightning, improper voltage or mishandling.
 - f) Labor charges for installation, removal or reinstallation of equipment.
- 7) The above listed warranty highlights do not constitute our total terms and conditions regarding warranty. For complete warranty information please refer to complete warranty statement herein.

LOSS OR DAMAGE IN TRANSIT

Immediately upon receipt, a complete inspection and accounting against the packing list should be made of all major components, and accompanying boxes or pallets. All material is shipped F.O.B. our factory, or our vendor's shipping point unless optional contractual arrangements are made. Under these terms, any claims for loss or damage in transit should be immediately directed to the delivering freight carrier. Fairbanks Nijhuis will assist the customer in receiving fair compensation, but assumes no responsibility to mediate such claims. This policy includes shipments wherein Fairbanks Nijhuis pays freight costs as part of the sales terms.

If there is any indication of oil leakage from the motor oil chamber, advise the factory immediately and request instructions for proper handling.

5 YEAR WARRANTY

FAIRBANKS NIJHUIS™ SUBMERSIBLE PUMPS AND MOTORS FOR USE IN MUNICIPAL SEWAGE COLLECTION: PERMANENT INSTALLATION

Fairbanks Nijhuis ("Seller") extends a five (5) year prorated limited warranty from date of shipment on submersible pumps and motors of its own manufacture against defects in materials and workmanship. The Buyer must give written notice of any alleged defect covered by this warranty within a reasonable time after the claim arises which time shall not exceed thirty (30) days. No claim made after the expiration of the warranty shall be valid. Seller does not warrant accessories or components that are not manufactured by Seller. However, to the extent possible, Seller agrees to assign to Buyer its rights under the original manufacturer's warranty, without recourse to Seller.

Guarantees of performance and warranties are based on the use of original equipment, manufactured (OEM) replacement parts. Seller assumes no responsibility or liability if alterations, nonauthorized design modifications and/or non-OEM replacement parts are incorporated.

This warranty shall run for a period of five (5) years from the date of shipment for pumps and motors, permanently installed, maintained and operated in accordance with the Fairbanks Nijhuis Installation, Operation and Maintenance Manuals in use at the time of sale and as amended from time to time to the extent the Buyer has notice of such amendments. Warranty is void if moisture detectors and thermostats are not properly wired and if electrical cable between motor control panel and motor is spliced.

If requested by Seller, any equipment (or its component parts) must be promptly returned to Seller prior to any attempted repair, or sent to an authorized service station designated by Seller, and Buyer shall prepay all shipping expenses. Seller shall not be liable for any loss or damage to goods in transit, nor will any warranty claim be valid unless the returned goods are received intact and undamaged as a result of shipment. Repaired or replaced material returned to customer will be shipped F.O.B. Seller's factory. Seller will not give Buyer credit for parts or equipment returned to Seller, and will not accept delivery of any such parts or equipment, unless Buyer has obtained Seller's approval in writing.

Repair parts of its own manufacture sold after the original warranty period are warranted for a period of one (1) year from shipment against defects in materials and workmanship under normal use and service. This warranty applies to the replacement parts, and labor to replace those parts, and is not extended to the product or any other component of the product being repaired.

THIS WARRANTY IS THE SOLE WARRANTY OF FAIRBANKS NIJHUIS AND FAIRBANKS NIJHUIS EXPRESSLY DISCLAIMS AND BUYER WAIVES ALL OTHER WARRANTIES EXPRESSED, IMPLIED IN LAW OR IMPLIED IN FACT, INCLUDING ANY WARRANTIES OF MERCHANTABILITY OR FITNESS FOR A PARTICULAR PURPOSE. This warranty does not apply to parts that fail due to abuse or normal wear (including, but not limited to impeller, wearing rings, seals and bearings). Under the terms of this warranty, Fairbanks Nijhuis shall not be liable for: (a) consequential, incidental, collateral, special or liquidated losses or damages; (b) equipment conditions caused by normal wear and tear, abnormal conditions of use, improper operation, acts of God, accident, neglect, or misuse of said equipment; (c) the expense of, and loss or damage caused by, repairs or alterations made by anyone other than those authorized by Fairbanks Nijhuis; (d) damage caused by abrasive materials, chemicals, scale deposits, corrosion, lightning, improper voltage, mishandling, or other similar conditions; (e) any loss, damage or expense relating to or resulting from installation, removal or reinstallation of equipment; (f) any expense of shipment of equipment or repaired or replacement parts; or (g) any other loss damage or expense of any nature. The liability of Fairbanks Nijhuis shall in no event exceed the purchase price of the individual unit of equipment paid by the original Buyer.

The Buyer's exclusive remedy under this warranty shall be for Fairbanks Nijhuis to repair on an adjusted basis the parts failing due to defects in materials, workmanship and labor to replace those parts during the warranty period. The Buyer will be invoiced for such repairs at the prorated percentage rate in the table below:

Repair Parts Price Factor

Months After Shipment	Sell Price Factor
0-18*	No Charge
Thru 36	.50
37 - 48	.70
49 - 60	.80

* Or not to exceed 12 months after installation, whichever comes first.

All repairs or service which are not covered by this warranty will be charged in accordance with standard prices in effect. In-shop labor for motor or pump repairs for the first 12 months after installation will be at no charge. After this period, labor charges for repair are the responsibility of the Buyer. Charges for removal, transportation, reinstallation and all associated additional cost, are not covered under warranty. Fairbanks Nijhuis shall have the option, but shall not be obligated, to provide in lieu of repair a replacement for any equipment that is defective.

CONDITION TO WARRANTY WORK: If Buyer is in default (including, but not limited to, the failure of Buyer to maintain a current account with Seller) under the Order or any other agreement between Buyer and Seller, Buyer's rights under the warranty shall be suspended and the original warranty period will not be extended.

PERFORMANCE: Equipment performance is not warranted or guaranteed unless separately agreed to by Seller in accordance with its guarantee policy. Performance curves and other information submitted to Buyer are approximate and no warranty or guarantee shall be deemed to arise as a result of such submittal. All testing shall be done in accordance with Seller's standard policy..

KC685/0393 (Revised)

15 MONTH PRORATED WARRANTY

FAIRBANKS NIJHUIS™ SUBMERSIBLE PUMPS AND MOTORS FOR USE IN INDUSTRIAL: PERMANENT INSTALLATION

Fairbanks Nijhuis ("Seller") warrants Submersible Pumps & Motors of its own manufacture against defects in materials and workmanship under normal use and service for 15 months from the date of shipment. Seller does not warrant accessories or components that are not manufactured by Seller. However, to the extent possible, Seller agrees to assign to Buyer its rights under the original manufacturer's warranty, without recourse to Seller. Buyer must give Seller notice in writing of any alleged defect covered by this warranty (together with all identifying details, including the serial number, the type of equipment, and the date of purchase) within thirty (30) days of the discovery of such defect during the warranty period. No claim made more than 30 days after the expiration of the warranty period shall be valid.

The Buyer's exclusive remedy under this warranty shall be for Seller to repair on an adjusted basis the parts failing due to defects in materials and workmanship during the warranty period. The Buyer will be invoiced for such repairs at the prorated percentage rate in the table below:

Repair Parts Price Factor

Months After Shipment	Sell Price Factor
0 - 7-1/2	No Charge
7-1/2 - 15	.50

Guarantees of performance and warranties are based on the use of original equipment manufactured (OEM) replacement parts. Fairbanks Nijhuis assumes no responsibility or liability if alterations, non-authorized design modifications and/or non-OEM replacement parts are incorporated.

Warranty is void if moisture detectors and thermostats are not properly wired and if electrical cables between motor control panel and motor is spliced.

If requested by Seller, any equipment (or its component parts) must be promptly returned to Seller prior to any attempted repair, or sent to an authorized service station designated by Seller, and Buyer shall prepay all shipping expenses. Seller shall not be liable for any loss or damage to goods in transit, nor will any warranty claim be valid unless the returned goods are received intact and undamaged as a result of shipment. Repaired or replaced material returned to customer will be shipped F.O.B. Seller's factory. Seller will not give Buyer credit for parts or equipment returned to Seller, and will not accept delivery of any such parts or equipment, unless Buyer has obtained Seller's approval in writing.

The warranty extends to repaired or replaced parts of Seller's manufacture for ninety (90) days or for the remainder of the original warranty period applicable to the equipment or parts being repaired or replaced. This warranty applies to the repaired or replaced part and is not extended to the product or any other component of the product being repaired.

Repair parts of its own manufacture sold after the original warranty period are warranted for a period of one (1) year from shipment against defects in materials and workmanship under normal use and service. This warranty applies to the replacement part only and is not extended to the product or any other component of the product being repaired.

Seller may substitute new equipment or improve part(s) of any equipment judged defective without further liability. All repairs or services performed by Seller, which are not covered by this warranty, will be charged in accordance with Seller's standard prices then in effect.

THIS WARRANTY IS THE SOLE WARRANTY OF SELLER AND SELLER HEREBY EXPRESSLY DISCLAIMS AND BUYER WAIVES ALL OTHER WARRANTIES EXPRESSED, IMPLIED IN LAW OR IMPLIED IN FACT, INCLUDING ANY WARRANTIES OF MERCHANTABILITY OR FITNESS FOR A PARTICULAR PURPOSE. Seller's sole obligation under this warranty shall be, at its option, to repair or replace any equipment (or its component parts) which has a defect covered by this warranty, or to refund the purchase price of such equipment or part. Under the terms of this warranty, Seller shall not be liable for (a) consequential, collateral, special or liquidated losses or damages; (b) equipment conditions caused by normal wear and tear, abnormal conditions of use, accident, neglect, or misuse of said equipment; (c) the expense of, and loss or damage caused by, repairs or alterations made by anyone other than the Seller; (d) damage caused by abrasive materials, chemicals, scale deposits, corrosion, lightning, improper voltage, mishandling, or other similar conditions; (e) any loss, damage, or expense relating to or resulting from installation, removal or reinstallation of equipment; (f) any expense of shipment of equipment or repaired or replacement parts; or (g) any other loss, damage or expense of any nature. The liability of Fairbanks Nijhuis shall in no event exceed the purchase price of the individual unit of equipment paid by the original Buyer.

All repairs or service which are not covered by this warranty will be charged in accordance with standard prices in effect. In-shop labor for motor or pump repairs for the first 7-1/2 months after shipment will be at no charge. In-shop labor for motor or pump repairs between 7-1/2 months and 15 months after shipment will be covered 50% by this warranty. After this period, labor charges for repair are the responsibility of the Buyer.

CONDITION TO WARRANTY WORK: If Buyer is in default (including, but not limited to, the failure of Buyer to maintain a current account with Seller) under the Order or any other agreement between Buyer and Seller, Buyer's rights under the warranty shall be suspended and the original warranty period will not be extended.

PERFORMANCE: Equipment performance is not warranted or guaranteed unless separately agreed to by Seller in accordance with its guarantee policy. Performance curves and other information submitted to Buyer are approximate and no warranty or guarantee shall be deemed to arise as a result of such submittal. All testing shall be done in accordance with Seller's standard policy.

KC885/0393

9 MONTH WARRANTY

FAIRBANKS NIJHUIS™ SUBMERSIBLE PUMPS AND MOTORS FOR USE IN CONSTRUCTION/MINING: PORTABLE INSTALLATION

Fairbanks Nijhuis ("Seller") warrants Submersible Pumps & Motors of its own manufacture against defects in materials and workmanship under normal use and service for 9 months from the date of shipment. Seller does not warrant accessories or components that are not manufactured by Seller. However, to the extent possible, Seller agrees to assign to Buyer its rights under the original manufacturer's warranty, without recourse to Seller. Buyer must give Seller notice in writing of any alleged defect covered by this warranty (together with all identifying details, including the serial number, the type of equipment, and the date of purchase) within thirty (30) days of the discovery of such defect during the warranty period. No claim made more than 30 days after the expiration of the warranty period shall be valid.

Guarantees of performance and warranties are based on the use of original equipment manufactured (OEM) replacement parts. Seller assumes no responsibility or liability if alterations, non-authorized design modifications and/or non-OEM replacement parts are incorporated.

Warranty is void if moisture detectors and thermostats are not properly wired and if electrical cables between motor control panel and motor is spliced.

If requested by Seller, any equipment (or its component parts) must be promptly returned to Seller prior to any attempted repair, or sent to an authorized service station designated by Seller, and Buyer shall prepay all shipping expenses. Seller shall not be liable for any loss or damage to goods in transit, nor will any warranty claim be valid unless the returned goods are received intact and undamaged as a result of shipment. Repaired or replaced material returned to customer will be shipped F.O.B. Seller's factory. Seller will not give Buyer credit for parts or equipment returned to Seller, and will not accept delivery of any such parts or equipment, unless Buyer has obtained Seller's approval in writing.

The warranty extends to repaired or replaced parts of Seller's manufacture for ninety (90) days or for the remainder of the original warranty period applicable to the equipment or parts being repaired or replaced. This warranty applies to the repaired or replaced part and is not extended to the product or any other component of the product being repaired.

Repair parts of its own manufacture sold after the original warranty period are warranted for a period of one (1) year from shipment against defects in materials and workmanship under normal use and service. This warranty applies to the replacement part only and is not extended to the product or any other component of the product being repaired.

Seller may substitute new equipment or improve part(s) of any equipment judged defective without further liability. All repairs or services performed by Seller, which are not covered by this warranty, will be charged in accordance with Seller's standard prices then in effect.

THIS WARRANTY IS THE SOLE WARRANTY OF SELLER AND SELLER HEREBY EXPRESSLY DISCLAIMS AND BUYER WAIVES ALL OTHER WARRANTIES EXPRESSED, IMPLIED IN LAW OR IMPLIED IN FACT, INCLUDING ANY WARRANTIES OF MERCHANTABILITY OR FITNESS FOR A PARTICULAR PURPOSE. Seller's sole obligation under this warranty shall be, at its option, to repair or replace any equipment (or its component parts) which has a defect covered by this warranty, or to refund the purchase price of such equipment or part. Under the terms of this warranty, Seller shall not be liable for (a) consequential, collateral, special or liquidated losses or damages; (b) equipment conditions caused by normal wear and tear, abnormal conditions of use, accident, neglect, or misuse of said equipment; (c) the expense of, and loss or damage caused by, repairs or alterations made by anyone other than the Seller; (d) damage caused by abrasive materials, chemicals, scale deposits, corrosion, lightning, improper voltage, mishandling, or other similar conditions; (e) any loss, damage, or expense relating to or resulting from installation, removal or reinstallation of equipment; (f) any expense of shipment of equipment or repaired or replacement parts; or (g) any other loss, damage or expense of any nature. The liability of Fairbanks Nijhuis shall in no event exceed the purchase price of the individual unit of equipment paid by the original Buyer.

All repairs or service which are not covered by this warranty will be charged in accordance with standard prices in effect. In-shop labor for motor or pump repairs for the first 9 months after shipment will be at no charge. After this period, labor charges for repair are the responsibility of the Buyer. by this warranty. After this period, labor charges for repair are the responsibility of the Buyer.

CONDITION TO WARRANTY WORK: If Buyer is in default (including, but not limited to, the failure of Buyer to maintain a current account with Seller) under the Order or any other agreement between Buyer and Seller, Buyer's rights under the warranty shall be suspended and the original warranty period will not be extended.

PERFORMANCE: Equipment performance is not warranted or guaranteed unless separately agreed to by Seller in accordance with its guarantee policy. Performance curves and other information submitted to Buyer are approximate and no warranty or guarantee shall be deemed to arise as a result of such submittal. All testing shall be done in accordance with Seller's standard policy.

KC985/0393

INTRODUCTION

Congratulations! You are the new owner of the finest pump commercially available. If you give it the proper care as outlined and recommended by this manual, it will provide you with reliable service and long life.

IMPORTANT

- **Read this complete manual and manuals for all component equipment before assembly or installation is started. It contains information which is the result of engineering and research efforts. It is designed to supply adequate instructions for the installation, operation and maintenance of your pump. Failure or neglect to properly install, operate or maintain your pump may result in personal injury, property damage or unnecessary damage to the pump.**

This manual applies to the pump installation, operation and maintenance. They are intended to be general and not specific. If your operating conditions ever change, always refer to the factory for reapplication. Always refer to the manuals provided by manufacturers of the accessory equipment for their separate instructions.

Variations exist in both the equipment used with these pumps and in the particular installation of the pump and driver. Therefore, specific operating instructions are not within the scope of this manual. The manual contains general rules for installation, operation and maintenance of the pump. If there are questions regarding the pump or its application which are not covered in this manual, please contact the factory as follows:

Fairbanks Nijhuis™
3601 Fairbanks Avenue
Kansas City, Kansas 66106
Phone 913/371-5000, Fax 913/748-4025

To obtain additional data on hydraulics and pump selection and operation, we suggest you purchase both of the following reference books:

1. The Fairbanks Nijhuis “Hydraulic Handbook” available from the Kansas City factory.
2. “Hydraulic Institute Standards” from the Hydraulic Institute, 9 Sylvan Way, Parsippany, NJ 07054-3802.

SUBMERSIBLE PUMP/MOTOR PRESTART-UP AND START-UP CHECKLIST

Contractor _____ Pump Serial Number _____
 Project Name _____ Pump Model Number _____
 Date of Shipment _____ Motor Serial Number _____

Procedure	Yes	No	N/A	Comments
1. Shipment				
Was there any damage in transit? (If so, has freight claim been filed?)				_____
Were all items received?				_____
2. Storage				
Has equipment been protected from the elements?				_____
Was equipment subject to flooding?				_____
3. Installation (All)				
Is grouting under base or elbow properly compacted?				_____
Is grouting of the non-shrink type?				_____
Have proper anchor bolts been used?				_____
Have the bolts been properly tightened?				_____
If motor is furnished with a water jacket and piped to external water source, what are flow & pressure readings? _____ GPM, _____ PSI.				_____
Installation (M or MV Pull-Up)				
Is fit between pull-up adapter and elbow correct?				_____
Are guide rails plumb and straight?				_____
Is power and control cable protected from possible damage?				_____
Installation (W)				
Has discharge been checked for pipe strain?				_____
Installation (W/D)				
Have both suction & discharge been checked for pipe strain?				_____
4. Rotation				
Has the rotation of the drives been checked for correct rotation?				_____
Are moisture detectors wired into controls?				_____
Are thermostats wired into controls?				_____
Is motor wired to a continuous meggering device?				_____
Do controls have proper disconnect protection?				_____
Are heater coils correctly sized and installed properly?				_____
Are controls wired with an alarm that will promptly notify personnel if a problem develops?				_____
6. System				
Has the system been checked to insure that it is free of foreign matter which could be damaging to the pump?				_____
Is liquid available to the pump?				_____
Has assurance been obtained from responsible parties that all piping is secure and that the routing of flow has been established and is correct?				_____
Are liquid levels properly set?				_____
7. Start-Up				
Has flow been established? Flow rate: _____ GPM				_____
Have gauge readings been taken? Suction pressure: _____ PSI				_____
Discharge pressure: _____ PSI				_____
Is excessive vibration present?				_____
What is recorded line voltage? _____ volts				_____
What is motor amp draw on each leg? 1.) _____ 2.) _____ 3.) _____				_____
8. Safety				
Have all safety labels been read and understood?				_____

Name _____ Date _____
 Name _____ Date _____

CALIFORNIA PROPOSITION 65 WARNING:**WARNING:**

This product and related accessories contain chemicals known to the State of California to cause cancer, birth defects or other reproductive harm.

SAFETY

Safety should be of utmost importance when in close proximity of this pumping equipment. Before attempting to operate this equipment, you should read this manual in its entirety, taking special notice of all CAUTIONS, WARNINGS and/or DANGER notifications. These warnings apply to pumps supplied by Fairbanks Nijhuis™. Refer to manuals supplied by the manufacturer of accessory items for additional warnings before operating this equipment. The words DANGER, WARNING and CAUTION have different connotations and are generally defined as follows:

 **DANGER**

- **DANGER** indicates an imminently hazardous situation which, if not avoided, will result in death or serious injury.

 **WARNING**

- **WARNING** indicates a potentially hazardous situation that, if not avoided, will result in serious injury.

 **CAUTION**

- **CAUTION** indicates a potentially hazardous situation that, if not avoided, may result in minor or moderate injury or may indicate that improper practices will result in equipment malfunction or failure. It may also be used to alert against unsafe practices.

IMPORTANT

- **Another notation will appear throughout this manual. IMPORTANT indicates the highlight or accent of specific information.**

The installation, use and operation of this type of equipment is affected by various Federal, State and Local Laws, and the regulations concerning OSHA. Compliance with such laws relating to the proper installation and safe operation of this type of equipment is the responsibility of the equipment Owner and all necessary steps should be taken by the Owner to assure compliance with such laws before operating the equipment.

 **DANGER**

- **Do not attempt to service the pump until the electrical power has been disconnected and it has been verified that the pump cannot start. Because many installations utilize automatic starting equipment, the pump unit may start at any time without warning. Proper precautions should be taken to avoid injury as a result of automatic starting of the equipment.**

 **DANGER**

- **This product has been designed specifically for operation in water or sewage. Do not use with other liquids without first consulting the factory.**

 **WARNING**

- **Do not attempt to try to clean the pump with bare hands. The pumped material may contain items that may present health hazards such as needles, and other sharp objects. Always wear heavy puncture resistant gloves.**

 **WARNING**

- Before attempting to service this pump:
 1. Familiarize yourself with this manual.
 2. Disconnect or lock out the power source to insure the pump will not start. Confirm power source disconnect with appropriate electrical test equipment.
 3. Close the discharge valve, and if present, the suction valve.

After the pump has been installed, make certain that the pump and all piping connections are tight and are properly supported prior to start-up and operation.

 **WARNING**

- Certain procedures in disassembly and assembly require parts be heated to high temperatures. Heat resistant gloves must be worn when handling heated parts. Heated parts can cause severe personal injury.

 **CAUTION**

- This manual contains general instructions for installation and operation of Explosion-Proof Submersible Pumps. Since pumping station designs and selected electrical controls will vary significantly between various installations, only general wiring diagrams for the motor and controls are shown in this manual.

STORAGE OF PUMPS

IMPORTANT

- If the equipment is not to be immediately installed and operated, **THE FOLLOWING INSTRUCTIONS SHOULD BE ADHERED TO AS A MINIMUM.**

Consider a unit in storage when:

1. It has been delivered to the jobsite and is awaiting installation.
2. It has been installed but operation is delayed pending completion of plant construction.
3. There are long (30 days or more) periods between operation cycles.
4. The plant (or facility) is shut down.

NOTE: Improper storage could result in product failures or restoration not covered by warranty.

If the pumps and motors are not immediately installed and operated, vertically store them in a clean, dry, well-ventilated area, free from vibration, moisture, and rapid or wide variations in temperature. Rotate the motor shaft by hand several revolutions every 4 weeks to ensure the bearing and seal components are coated with oil for protection against corrosion.

 **CAUTION**

- Keep ends of power and control cables clean and dry, do not submerge in water or sewage. Doing so will result in permanent damage.

GENERAL

The Model D5430, D5730 and D2430 pumps consist of several components. The following is a list of those major parts (or component assemblies) and a brief description of their design and function.

Impellers All Models 5430, 5730, 2430

The impeller is a balanced solids-handling type made of close-grained cast iron. The impeller is a one piece, single suction, enclosed radial flow design with well-rounded leading vanes and then tapered toward the trailing edge for a circular flow pattern. The waterways through the impeller have extremely smooth contours, devoid of sharp corners, so as to minimize rags, stringy or fibrous material from catching or clogging. The impeller is balanced and secured to the shaft by means of a bolt and key. The arrangement is such that the impeller cannot be loosened from torque in either forward or reverse rotation.

Volute/Sliding Bracket (Pull-Up) (D5430, D5730, D2430 M, MT, MV, MVS)

The volute is matched to the impeller and made of close-grained cast iron. The volute is of one-piece constant velocity, equalizing pressure design with smooth fluid passage large enough to pass any size solid that can pass through the impeller and shall include a flanged discharge connection.

The sliding bracket assembly is a part of the pumping unit, constructed so that when lowered onto the discharge base/elbow, the knifing action of the vertical metal-to-metal seal provides a self-cleaning, solids-handling, UL listed, non-sparking assembly.

Guide Rail Brackets (Pull-Up) (D5430, D5730, D2430 M, MT, MV, MVS)

An upper guide bracket is supplied to support and align the guide rails (supplied by others). When specified, an intermediate guide bracket is supplied for additional support.

Discharge Base (Pull-Up)

A rigid discharge base-elbow, designed to support the total weight of the pumping unit, is provided. The base is to be bolted to the foundation with appropriate anchor bolts in full contact with grout. The 90 degree elbow having a 125 lb. ANSI flange discharges vertically (MVS discharges horizontally).

Fits and Hardware

The volute and fronthead are manufactured with concentric shoulder fits to assure accurate alignment. All bolts, nuts and capscrews are stainless steel and are of the hex-headed type.

Motor

The Fairbanks Nijhuis™ Hazardous Location Submersible Motors are suitable for application in gases, where vapor or gas ignition temperatures are higher than the operating temperatures shown on the motor nameplate. The motors have a rated maximum operating skin temperature of 160 degrees C.

Motors up to and including 50 HP are designed for standard use with either 230V or 460V three-phase service depending on the nameplate rating. Standard motors larger than 50 HP are 460V only. On special order other voltages are available. All motor ratings are noted on the motor nameplate, and are based on operating in a 40 degree C ambient temperature. Insulation may be Class F, Class H or inverter duty as noted on the motor nameplate.

The standard motors have duty ratings for any one of three operating conditions: continuous duty in air, continuous duty submerged, and short time duty in air (one-hour duty in air for 210 frame motors, and 15 minutes for 250 and larger frame motors). For a more detailed discussion of these conditions, see the section on "Operation." The 250 Frame and larger motors have an optional water jacket construction, and are then rated for continuous operation in air.

The motor is mounted directly on the pump volute, and the pump impeller is installed on the motor shaft. For those motors with the optional water jackets, cooling water is provided continuously by the circulator, without any external piping or connections. (Optional external water source cooling is available.) All motor housing joints are equipped with long rabbet fits and O-ring seals. The housing and the water jacket are made of close grain cast iron. The motor shaft and all external nuts and bolts are stainless steel.

Motors have single row, upper radial ball bearing. The 210 frame uses a single row, lower thrust ball bearing. The 220 frame uses a single row roller ball radial and thrust bearing. The 250 through 490 frame motors incorporate double row, lower thrust ball bearings. All bearings are grease lubricated for life (except 210 and 220 frames which are oil lubricated.)

The motor shaft is sealed with two mechanical seals, mounted in a tandem arrangement, and with an oil chamber between them. For 210 thru 365 frames the internal seal has Carbon/Ni-resist seal faces; the external seal, Carbon-Ceramic faces (optional seal materials are available.) Remaining seal components are Stainless Steel and Buna-N. For 400 thru 445 frames the inner seal is Ni-resist/Carbon seal faces; the external seal Silicon/Tungsten faces. For the 490/495 frame, the inner seal is Tungsten/Carbon seal faces; the outer seal is Silicon/Tungsten.

Since all mechanical seals must seep moisture to provide lubrication to the sealing faces, two moisture detector probes have been installed in the seal chamber. This system monitors the quantity of water in the oil chamber. When a mixture of 25 to 30% of water to oil is reached, the moisture controller will signal that it is time to change the oil. O-ring sealed fill and drain plugs are included for ease of changing oil in the oil chamber.

Thermostats in the motor windings are standard, and protect the motor from excessive winding temperatures. Power and control cables are epoxy-potted into the cover to prevent moisture from intruding into the motor. For additional protection of maintenance and operation personnel, it is highly recommended that the motor power circuitry have ground fault interruption capabilities.

Non-Clog: The term non-clog is commonly applied to centrifugal pumps designed for the municipal sewage market. Pumps referred to as non-clog are specially designed to accommodate the pumping of solids by providing larger than normal passage ways through the impeller and volute, minimizing the number of impeller vanes and volute cutwaters. In addition, the leading edges of the impeller vanes and the volute cutwater are well rounded to promote the shedding of long fibrous material. These features make non-clog pumps more resistant to plugging from the accumulation of solids in the pump than a pump of conventional design. However, no pump can ever be described as being completely resistant to clogging.

When the content of the pumpage includes large amounts of fibrous solids which cannot be removed prior to the pump, the sump design should be of the nature to allow the pumps to be run at near full speed, drawing down the sump and cycling the pumps on and off as required. This is particularly true during low flow periods when solids tend to settle out and accumulate at the bottom of the sump and in the suction piping. Low speed and low velocity pumping can even cause plugging in a vertical leg of the discharge piping. Reduced pump speed and low suction velocities must be avoided to reduce the tendency to clog. The sump and suction piping design should be of the "self-cleaning" design to avoid the accumulation of solids at these locations.

INSTALLATION

General



- **Carefully read all sections of this manual and all other instruction manuals supplied by manufacturers of other equipment supplied with this pump.**

Upon receipt of this shipment, unpack and inspect the pump/driver assembly and individual parts to ensure none are missing or damaged. Carefully inspect all boxes and packing material for loose parts to ensure none are missing or damaged. Carefully inspect all boxes and packing material for loose parts before discarding them. Report immediately to the factory, and the transportation company involved, any missing parts or damage incurred during shipment, and file your "damaged and/or lost in shipment" claim with the carrier immediately.

Piping



- **All piping connections must be made with the pipe in a rigid supported state, and without the need to apply vertical or side pressure to obtain alignment of the piping with pump flange.**

For all "W" and "WD" style units, all piping should be independently supported so that neither mechanical nor hydraulic pipe strain exists.

Discharge Piping

Discharge pipe should be as direct as possible with a minimum of valves to reduce pipe friction losses. A check valve and closing valve should be installed in the discharge line. The check valve, between the pump and closing valve, prevents reverse rotation in the event of power failure. The closing valves are used to isolate the pump for repairs.

Suction Piping

Suction pipe on “WD” pumps must be air tight and sloped upward to the pump flange to avoid air pockets which will impair satisfactory pump operation.

Installation 5430, 5730 and 2430 M, MT, MV or MVS

- A. Install the top guide bracket. Plumb the guide rails from the top guide bracket to locate the pump discharge base/elbow and assure proper alignment of the guide rails. Failure to do so will result in the pump discharge not properly seating against the discharge elbow, and could cause binding of the pump as it is raised and lowered in the sump.
- B. Lower the base elbow (76) onto the anchor bolts.
- C. Level the base elbow using metal shims or metal wedges spaced close enough to give uniform support and stability. When level and perpendicular, tighten the anchor bolt nuts snugly, but not too firmly.
- D. After leveling, the base elbow is to be grouted in place with a good quality non-shrinking grout. Leveling devices are to be removed or backed off and the pump base elbow tightened solidly against the grout bed. All pockets and/or holes left by removal of leveling devices are to be filled with grout.
- E. Install the discharge piping tightening all bolts and check for pipe strain.
- F. Install the guide rails (460), provided by others, (2” or 3” galvanized or stainless steel pipe) to the base elbow. If the guide rails are less than 20 feet in length, proceed to step H.
- G. If the guide rails are over 20 feet in length, an intermediate guide bracket is used. Install the “u”-bolt around the discharge pipe near the top of the lower section of guide rail, and hand tighten the bolts to the bracket. Slip the rubber bushings down inside the guide rails and tighten with the spreader bolts. Tighten the “u”-bolt nuts securing the bracket to the discharge pipe. Lower the top rails onto the intermediate guide bracket.
- H. Install the top guide bracket over the guide rails inserting the rubber bushings into the guide rails and tighten with the spreader bolts. Shim between the back of the top guide bracket and the well curb to obtain strain-free vertical positioning of the guide rails.
- I. Tighten the bolts of the retainer bracket support to the well curb.
- J. Attach one end of a suitable lifting cable or chain to the metal motor bail with the other end attached to a suitable lift or hoist.

- **Note: If the Optional Sure Pick Lifting System is to be used, refer to that section in this manual.**

WARNING

- **Prior to lifting the unit, check to ensure all hooks, cables, chains and hoists are of adequate strength and size. Refer to Pump Data Section of this manual for approximate pump weights.**
 - **Lifting mechanism capability should NOT exceed two times the weight of the pump to avoid damage. (Refer to Technical Data tables.)**
 - **Lifting mechanism sheave shall have a diameter large enough so as to not crimp or severely bend the lifting cable. Small diameter or angle type sheaves could cause cable failure.**
 - **Do not lift by the power or control cable. Damage will result.**
- K. With an adequate hoist, lower the pump onto the guide rails and into the wet pit. **The location of the hoist should be in a position so that the centerline of the pump pull up bracket guide is within 1/2” of the centerline of the guide rails.**
 - L. The pump is self-connecting to the base elbow. No bolting or other fastening is required. Check to ensure there is proper seating between the pump discharge flange and the base elbow flange. If not, raise the pump partially back up the guide rails and again lower onto the base below.
 - M. Install the controls per the control manufacturer’s recommendations.
 - N. Wire the motor protection devices.

The 210 through 400 frame motors are supplied with one 4-lead power cable. 440 and larger frame motors are supplied with two 4-lead power cables. On the 250 through 400 frame motors that have the RTD bearing detector, the control wire has 7 wires. Control cable on standard motors is 5-lead. On 440 frames and larger, the control cable is 8-lead. Lead color codes and terminal connections are outlined in the following tables:

Power Cable Terminal Connections (1)					
Lead Color Code					
Frame	Black	White	Red	Orange	Green
210 through 400	T3	T1	T2	-----	Ground
440 thru 495	T3, T5	T1, T6	T2, T4	-----	Ground

Control Cable Terminal Connections (2)									
Control Device	Frame	Lead Color Code							
		Black	Blue	White	White/ Black	Red/ Black	Red	Orng	Grn
Thermo- stats	210 Thru 400	P2	N/A	P1	N/A	N/A	N/A	N/A	Grd
	440/445	P2	N/A	P1	N/A	N/A	N/A	N/A	Grd
	490/495	P2	N/A	P1	N/A	N/A	N/A	N/A	Grd
Moisture Detector	210 Thru 400	N/A	N/A	N/A	N/A	W2	N/A	W1	Grd
	440/445	N/A	N/A	N/A	N/A	W1	N/A	W2	Grd
	490/495	N/A	N/A	N/A	N/A	W2	N/A	W1	Grd
Optional Bearing RTD	250 Thru 365	N/A	R3	N/A	R2	N/A	N/A	N/A	Grd
	440/445	N/A	R1	N/A	R2	N/A	R3	N/A	Grd
	490/495	N/A	R1	N/A	R2	N/A	R3	N/A	Grd

(1) Power leads connect the motor to the power supply.

(2) Control leads connect thermostats, moisture detectors and optional thrust bearing RTD controls.

CAUTION

- The cable cannot be spliced.

Figure #3 in the drawing section of this manual shows the simplified schematic wiring diagram for 210 and 220 frame motors. Figures #4 and #5 show the simplified schematic wiring diagram for 250, 320, and 360/365 frame motors. Figures #6 and #7 show the simplified schematic wiring diagrams for 440 and larger frame motors which are wye start, and when reduce voltage started and delta run. The thermostats should be wired in series with the stop button. Provision for manual reset of the motor after the thermostats trip is required. The thermostats themselves will reset automatically after the motor windings cool down.

WARNING

- All electric controls and motor starting equipment must be located outside the hazardous area unless they are approved for hazardous locations.

DANGER

- The disconnect switch must be opened and locked out before any work is done on the motor-pump unit. Failure to take this precaution can result in serious injury or death.

The current through the thermostat shall not exceed the limits in the following table:

ALTERNATING CURRENT		
Volts	Continuous Amperes	In Rush Amperes
110-120	3.0	30.0
220-240	1.5	15.0
440-480	0.75	7.5
550-600	0.60	6.0

IMPORTANT

- **Thermostats must be connected in the circuit and must be operative. Running the motor with inoperative thermostats will void the warranty. Thermostat contact rating 120-600 VAC, 360 VA maximum.**

NOTE: Thermostats are not designed for locked rotor protection during cold starts. Panel should be wired so that quick trip heaters will take the motor off-line under this condition.

Fig. #8 included in the drawing section of this manual shows a typical wiring diagram for the moisture detectors for cable lengths of 125 feet or less. The detectors can be wired to shutdown the motor or to activate an indicator or alarm device, or to do both. (Sample moisture detection controllers are located in the drawing section of this manual.) A compatible controller must be connected to properly protect the motor. A controller rated for 500 volts A/C with a triggering resistance across the probes of 25,000 Ohm's is required.

IMPORTANT

- **Moisture detectors must be connected and functional. Operation of the pump without operative moisture detectors will void the motor warranty.**
- O. The direction of rotation should be checked before the pump is put in operation. Raise the pump back out of the wet-well and carefully lay it horizontally. The correct rotation of the pump is indicated by an arrow cast on the volute. While looking into the pump suction, "bump" start the motor to observe rotation.

DANGER

- **Do not put hands or any item in the volute suction to determine direction of rotation, as doing so will cause serious personal injury.**

Bump start is generally accomplished on three-phase motors by engaging and immediately disengaging the power switch. It is seldom necessary to engage the power source for more than one second to determine motor rotation.

Note the direction of impeller rotation. If the impeller rotates opposite the arrow on the pump volute, reverse any two of the three power leads and motor rotation will be reversed. (On the 440 and larger frame motors, two "sets" of power leads must be reversed.)

Both motor mechanical seals are lubricated and cooled by the oil in the oil chamber. Oil chamber is filled at the factory prior to shipment.

Installation 5430, 5730, 2430 W

A. Attach one end of a suitable lifting cable or chain to the metal motor bale or lifting harness with the other end attached to a suitable lift or hoist.

- **Note: If the Optional Sure Pick Lifting System is to be used, refer to that section in this manual.**



WARNING

- **Prior to lifting the unit, check to ensure all hooks, cables, chains and hoists are of adequate strength and size. Refer to the Pump Data Section of this manual for approximate pump weights.**
- **Lifting mechanism capability should NOT exceed two times the weight of the pump.**
- **Lifting mechanism sheave shall have a diameter large enough so as to not crimp or severely bend the lifting cable. Small diameter or angle type sheaves could cause cable failure.**
- **Do not lift by the power or control cable. Damage will result.**

B. With an adequate hoist, lower the pump into the wet pit.

C. Connect the discharge piping tightening all bolts and eliminate any pipe strain.

D. Install the controls per the control manufacturer's recommendations.

E. Wire the motor and motor protection devices.

The 210 through 400 frame motors are supplied with one 4-lead power cable. 440 and larger frame motors are supplied with two 4-lead power cables. On the 250 through 400 frame motors that have the RTD bearing detector, the control wire has 7 wires. Control cable on standard motors is 5-lead. If the optional thrust bearing RTD is supplied, the control cable is 8-lead. Lead color codes and terminal connections are outlined in the following tables:

Power Cable Terminal Connections (1)					
Lead Color Code					
Frame	Black	White	Red	Orange	Green
210 through 400	T3	T1	T2	-----	Ground
440 thru 495	T3, T5	T1, T6	T2, T4	-----	Ground

Control Cable Terminal Connections (2)									
Control Device	Frame	Lead Color Code							
		Black	Blue	White	White/ Black	Red/ Red	Red/ Black	Orng	Grn
Thermo- stats	210 Thru 400	P2	N/A	P1	N/A	N/A	N/A	N/A	Grd
	440/445	P2	N/A	P1	N/A	N/A	N/A	N/A	Grd
	490/495	P2	N/A	P1	N/A	N/A	N/A	N/A	Grd
Moisture Detector	210 Thru 400	N/A	N/A	N/A	N/A	W2	N/A	W1	Grd
	440/445	N/A	N/A	N/A	N/A	W1	N/A	W2	Grd
	490/495	N/A	N/A	N/A	N/A	W2	N/A	W1	Grd
Optional Bearing RTD	250 Thru 365	N/A	R3	N/A	R2	N/A	N/A	N/A	Grd
	440/445	N/A	R1	N/A	R2	N/A	R3	N/A	Grd
	490/495	N/A	R1	N/A	R2	N/A	R3	N/A	Grd

(1) Power leads connect the motor to the power supply.

(2) Control leads connect thermostats, moisture detectors and optional thrust bearing RTD controls.

CAUTION

- The cable cannot be spliced.

Figure #3 in the drawing section of this manual shows the simplified schematic wiring diagram for 210 and 220 frame motors. Figures #4 and #5 show the simplified schematic wiring diagram for 250, 320 and 360/365 frame motors. Figures #6 and #7 show the simplified schematic wiring diagrams for 440 and larger frame motors which are wye start, and when reduce voltage started and delta run. The thermostats should be wired in series with the stop button. Provision for manual reset of the motor after the thermostats trip is recommended. The thermostats themselves will reset automatically after the motor windings cool down.

WARNING

- All electric controls and motor starting equipment must be located outside the hazardous area unless they are approved for hazardous locations.

DANGER

- The disconnect switch must be opened and locked out before any work is done on the motor-pump unit. Failure to take this precaution can result in serious injury or death.

The current through the thermostat shall not exceed the limits in the following table:

ALTERNATING CURRENT		
Volts	Continuous Amperes	In Rush Amperes
110-120	3.0	30.0
220-240	1.5	15.0
440-480	0.75	7.5
550-600	0.60	6.0

IMPORTANT

- **Thermostats must be connected in the circuit and must be operative. Running the motor with inoperative thermostats will void the warranty. Thermostat contact rating 120-600 VAC, 360 VA maximum.**

Fig. #8 included in the drawing section of this manual shows a typical wiring diagram for the moisture detectors for cable lengths of 125 feet or less. The detectors can be wired to shutdown the motor or to activate an indicator or alarm device, or to do both. (Sample moisture detection controllers are located in the drawing section of this manual.) A compatible controller must be connected to properly protect the motor. A controller rated for 500 volts A/C with a triggering resistance across the probes of 25,000 Ohm's is required.

IMPORTANT

- **Moisture detectors must be connected and functional. Operation of the pump without operative moisture detectors will void the motor warranty.**

F. The direction of rotation should be checked before the pump is put in operation. Raise the pump back out of the wet-well and carefully lay it horizontally. The correct rotation of the pump is indicated by an arrow cast on the volute. While looking into the pump section, "bump" start the motor to observe rotation.

DANGER

- **Do not put hands or any item in the volute suction to determine direction of rotation, as doing so will cause serious personal injury.**

Bump start is generally accomplished on three-phase motors by engaging and immediately disengaging the power switch. It is seldom necessary to engage the power source for more than one second to determine motor rotation.

Note the direction of impeller rotation. If the impeller rotates opposite the arrow on the pump volute, reverse any two of the three power leads and motor rotation will be reversed. (On 440 frame motors two "sets" of power leads must be reversed.)

Both motor mechanical seals are lubricated and cooled by the oil in the oil chamber. Oil chamber is filled at the factory prior to shipment.

Installation 5430, 5730 and 2430 WD

- A. The pump should be installed as near the wet well as possible so that a short direct suction pipe can be used to keep suction losses at a minimum. Total net position suction head available (NPSHA), which includes suction lift and pipe friction losses, must be greater than the net positive suction head required (NPSHR) by the pump. Discharge piping should be direct and with as few elbows and fittings as possible.
- B. Pump should be located in an area that will permit periodic inspection and maintenance. Head and access room should be provided.
- C. Lower the unit onto the foundation and position the base so the anchor bolts are aligned in the middle of the holes in the base.

WARNING

- **Prior to lifting the unit, check to ensure all hooks, cables, chains and hoists are of adequate strength and size. Refer to Pump Data Section of this manual for approximate pump weights.**
 - **Do not lift by the power or control cable. Damage will result.**
- D. Set the base on metal shims or metal wedges placed directly under the part of the base carrying the greatest weight, and spaced close enough to give uniform support and stability.

Adjust the metal shims or wedges until level or vertical as appropriate. Make sure that all shims or wedges fit firmly between the foundation and the base.

If leveling nuts are installed on the anchor bolts and are used for alignment, follow the same procedure as with shims or wedges. Support the base with additional shims or wedges if necessary. Make sure that all nuts and shims are in firm contact with the base. Tighten the foundation bolts snugly, but not too firmly.

- E. The unit should be grouted using a high grade non-shrinking grout. The base is designed to be completely filled with grout.

CAUTION

- **Damaging vibration may result if the baseplate is not solidly in contact with the grout bed.**

Do not fill the pipe sleeves with grout. If leveling nuts are used, make sure they are not imbedded in grout. Provide access in the grout to the leveling nuts so that they can be backed off after the grout has cured.

Allow the grout to fully cure before backing off the leveling nuts (if used) or removal of shims, and firmly tightening the foundation bolts.

CAUTION

- **All piping connections must be made with the pipe in a rigid support state, and without the need to apply vertical or side pressure to obtain alignment of the piping with pump flange.**

- F. All piping should be independently supported near the pump so that pipe strain will not be transmitted to the pump casing. The weight of the piping and of the contained liquid must be considered in support design. Suction and discharge piping should be one or two sizes larger than the pump flange sizes, especially where the piping is of considerable length. Any flexible joints installed in the piping must be equipped with tie rods to absorb piping axial thrust.

Suction pipe must be air tight and sloped upward to the pump flange to avoid air pockets which will impair satisfactory pump operation. The discharge pipe should be as direct as possible with a minimum of valves to reduce pipe friction losses.

A check valve and closing valve should be installed in the discharge line. The check valve, between the pump and closing valve, prevents reverse rotation in the event of power failure. Closing valves are used for priming and to isolate the pump for repairs. The pump must never be throttled by the use of a valve in the suction line.

- G. In addition to the primary piping connections, your pump may require connections to the water jacket (if external water source is used), and suction and discharge pressure gauges. All of these connections should now be made.

IMPORTANT

- **These auxiliary pipe lines must be kept clean for satisfactory pump operation and pump life.**

- H. Wire the motor protection devices.

The 210 through 400 frame motors are supplied with one 4-lead power cable. 440 and larger frame motors are supplied with two 4-lead power cables. On the 250 through 400 frame motors that have the RTD bearing detector, the control wire has 7 wires. Control cable on standard motors is 5-lead. If the optional thrust bearing RTD is supplied, the control cable is 8-lead. Lead color codes and terminal connections are outlined in the following tables:

Power Cable Terminal Connections (1)					
Lead Color Code					
Frame	Black	White	Red	Orange	Green
210 through 400	T3	T1	T2	-----	Ground
440 thru 495	T3, T5	T1, T6	T2, T4	-----	Ground

Control Cable Terminal Connections (2)									
Control Device	Frame	Lead Color Code							
		Black	Blue	White	White/ Black	Red	Red/ Black	Orng	Grn
Thermo- stats	210 Thru 400	P2	N/A	P1	N/A	N/A	N/A	N/A	Grd
	440/445	P2	N/A	P1	N/A	N/A	N/A	N/A	Grd
	490/495	P2	N/A	P1	N/A	N/A	N/A	N/A	Grd
Moisture Detector	210 Thru 400	N/A	N/A	N/A	N/A	W2	N/A	W1	Grd
	440/445	N/A	N/A	N/A	N/A	W1	N/A	W2	Grd
	490/495	N/A	N/A	N/A	N/A	W2	N/A	W1	Grd
Optional Bearing RTD	250 Thru 365	N/A	R3	N/A	R2	N/A	N/A	N/A	Grd
	440/445	N/A	R1	N/A	R2	N/A	R3	N/A	Grd
	490/495	N/A	R1	N/A	R2	N/A	R3	N/A	Grd

(1) Power leads connect the motor to the power supply.

(2) Control leads connect thermostats, moisture detectors and optional thrust bearing RTD controls.

CAUTION

- The cable cannot be spliced.

Figure #3 in the drawing section of this manual shows the simplified schematic wiring diagram for 210 and 220 frame motors. Figures #4 and #5 show the simplified schematic wiring diagram for 250, 320 and 360/365 frame motors. Figures #6 and #7 show the simplified schematic wiring diagrams for 440 and larger frame motors which are wye start, and when reduce voltage started and delta run. The thermostats should be wired in series with the stop button. Provision for manual reset of the motor after the thermostats trip is recommended. The thermostats themselves will reset automatically after the motor windings cool down.

WARNING

- All electric controls and motor starting equipment must be located outside the hazardous area unless they are approved for hazardous locations.

DANGER

- The disconnect switch must be opened and locked out before any work is done on the motor-pump unit. Failure to take this precaution can result in serious injury or death.

The current through the thermostat shall not exceed the limits below:

ALTERNATING CURRENT		
Volts	Continuous Amperes	In Rush Amperes
110-120	3.0	30.0
220-240	1.5	15.0
440-480	0.75	7.5
550-600	0.60	6.0

IMPORTANT

- **Thermostats must be connected in the circuit and must be operative. Running the motor with inoperative thermostats will void the warranty. Thermostat contact rating 120-600VAC, 360 VA maximum.**

Fig. #8 included in the drawing section of this manual shows a typical wiring diagram for the moisture detectors for cable lengths of 125 feet or less. The detectors can be wired to shutdown the motor or to activate an indicator or alarm device, or to do both. (Sample moisture detection controllers are located in the drawing section of this manual.) A compatible controller must be connected to properly protect the motor. A controller rated for 500 volts A/C with a triggering resistance across the probes of 25,000 Ohm's is required.

IMPORTANT

- **Moisture detectors must be connected and functional. Operation of the pump without operative moisture detectors will void the warranty.**
- I. The direction of rotation should be checked before the pump is put in operation. Remove the volute handhold cover (or suction elbow cleanout cover.) The correct rotation of the pump is indicated by an arrow cast on the volute. While looking into the cleanout opening, "bump" start the motor to observe rotation.

DANGER

- **Do not put hands or any item in cleanout to determine direction of rotation. To do so will cause serious personal injury.**

Bump start is generally accomplished on three-phase motors by engaging and immediately disengaging the power switch. It is seldom necessary to engage the power source for more than one second to determine motor rotation.

Note the direction of impeller rotation. If the impeller rotates opposite the arrow on the pump volute, reverse any two of the three power leads and motor rotation will be reversed. (On 440 frame motors two "sets" of power leads must be reversed.)

Both motor mechanical seals are lubricated and cooled by the oil in the oil chamber. Oil chamber is filled at the factory prior to shipment.

OPERATION

General

This section contains general rules for operation. Because variations may exist in a particular installation between the pumps, the drivers and the accessory equipment, specific operating instructions are not within the scope of this manual.

WARNING

- Before starting or operating the pump, read this entire manual and the control manufacturer's instructions for proper operating of the system, especially complying with the following instructions:

1. Duty Cycles:

5430, 5730, 2430 M, MT, MV or MVS

It is important that the motor be operated within the limits of its rating. Carefully note the "Duty" block on the motor nameplate. One of the following three ratings will be on the motor nameplate:

- a) If the Duty cycle reads "Cont. Submerged," it is required that the motor be continuously submerged.
- b) If the Duty cycle reads "Continuous in Air," it may be run non-submerged at its rated load. "Continuous in Air" units can also run submerged at its rated load.
- c) A Duty cycle of "Short Time in Air 15 Min." requires the following:

The capacity of the pump should be selected to be greater than the maximum flow into the wet well. Under maximum flow conditions, the pump must draw-down the sump from the top of the motor, Level A, to the bottom flange on the motor, Level B, within 15 minutes. See Fig. #1.

- d) A Duty cycle of "Short Time in Air 1 Hour" requires the following (210 and 220 frame only):

The capacity of the pump should be selected to be greater than the maximum flow into the wet well. Under maximum flow conditions, the pump should draw-down the sump from the top of the motor, Level A, to the bottom flange on the motor, Level B, within 1 hour. See Fig. #1.

The power frequency shall not vary by more than +/-5%, and the voltage by more than +/-10% of the nameplate data. Voltage deviation from the nameplate ratings will have an effect on pump speed and, therefore, on pump performance. The pump will deliver the rated head and capacity only when running at the rated speed.

Note: Voltage should not vary from phase to phase by more than 2% without derating the motor's horsepower rating. Damage may occur to the motor if operated with more variation.

CAUTION

- Proper voltage is required or permanent damage to the motor may occur. Check to ensure input voltage is the same as the motor rated voltage.

NOTE: Pumps should not be operated for extended periods of time (no more than 2-3 days) with the moisture indicator light on.

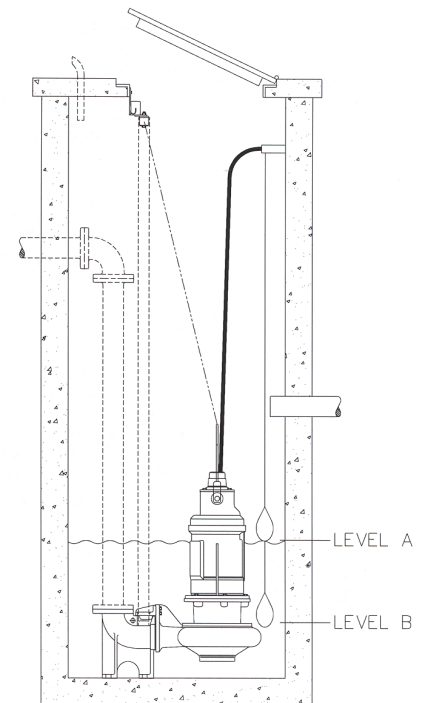

Figure 1

5430, 5730, 2430 W

It is important that the motor be operated within the limits of its rating. Carefully note the "Duty" block on the motor nameplate. One of the following three ratings will be on the motor nameplate:

- If the Duty cycle reads "Cont. Submerged", it is required that the motor be continuously submerged.
- If the Duty cycle reads "Continuous in Air", it may be run non-submerged at its rated load. "Continuous in Air" units can also run submerged at its rated load.
- A Duty cycle of "Short Time in Air 15 Min." requires the following:

Under maximum flow conditions, the pump must draw-down the sump from the top of the motor, Level A, to the bottom flange of the motor, Level B, within 15 minutes (see Fig. #2.)

- A Duty cycle of "Short Time in Air 1 Hour" requires the following (210 and 220 frameonly):

The capacity of the pump should be selected to be greater than the maximum flow into the wet well. Under maximum flow conditions, the pump should draw-down the sump from the top of the motor, Level A, to the bottom flange on the motor, Level B, within 1 hour. See Fig. #1.

The power frequency shall not vary by more than +/-5%, and the voltage by more than +/-10% of the nameplate data. Voltage deviation from the nameplate ratings will have an effect on the pump speed and, therefore, on pump performance. The pump will deliver the rated head and capacity only when running at the rated speed.

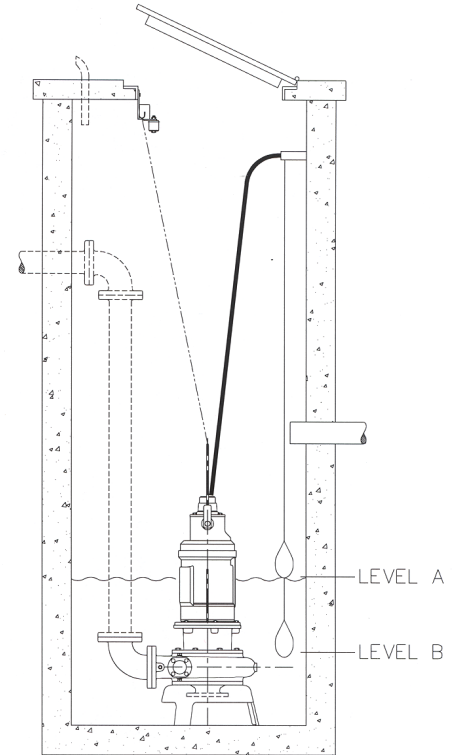

Figure 2

Note: Voltage should not vary from phase to phase by more than 2% without derating the motor's horsepower rating. Damage may occur to the motor if operated with more variation.

⚠ CAUTION

- **Proper voltage is required or permanent damage to the motor may occur. Check to ensure input voltage is the same as the motor rated voltage.**

5430, 5730, 2430 WD

It is important that the motor be operated within the limits of its rating. Carefully note the "Duty" block on the motor nameplate. One of the following two ratings will be on the motor nameplate:

- If the Duty cycle reads "Continuous in Air," it may be run non-submerged at its rated load. "Continuous in Air" units can also run submerged at its rated load.
- If the Duty cycle reads "Continuous in Air, Jacketed," it may be run non-submerged at its rated load.

The power frequency shall not vary by more than +/-10%, and the voltage by more than +/-10% of the nameplate data. Voltage deviation from the nameplate ratings will have an effect on pump speed and, therefore, on pump performance. The pump will deliver the rated head and capacity only when running at the rated speed.

Note: Voltage should not vary from phase to phase by more than 2% without derating the motor's horsepower rating. Damage may occur to the motor if operated with more variation.

⚠ CAUTION

- **Proper voltage is required or permanent damage to the motor may occur. Check to ensure input voltage is the same as the motor rated voltage.**

ALL PUMPS:

2. Make sure the moisture detection system is operational at all times. Note that all mechanical seals must seep to provide lubrication to the rotating faces. This is trapped in the oil chamber between the inner and outer seals. During

the initial run-in period, new seals may seep enough to cause the moisture alarm to go off. This is normal, change the oil and put the unit back into service.

3. Make sure both the suction (if required) and discharge valves are open.
4. Observe all caution, warning and danger tags that may be attached to the equipment.
5. Never run the pump longer than 15 minutes without liquid in the volute as close running fits within the pump are lubricated by the liquid. This condition may result in pump seizure, and/or seal damage.
6. Because of tight internal clearances these pumps should not run against a closed valve, unless approved by the factory.

Starting the Pump

5430, 5730, 2430 M, MT, MV, MVS or W

- A. Be sure the pump is submerged properly and that the liquid level exceeds the minimum operating level recommended.
- B. Refer to the motor nameplate for operation limits before proceeding.
- C. The pump requires no special procedures or adjustments before starting, except to check for rotation. The control system should be set to ensure no more than 10 across the line starts per hour on the 210 through the 365 frame motors, and 1 across the line start per hour on the 400 frame and larger motors.



- **Under no circumstances should any flammable liquids be pumped.**
- D. Start the unit.
 - E. Immediately after the pump has been started, check the following:
 - 1) Observe the unit for any unusual noise or vibration.
 - 2) The voltage should be within +/- 10% of the rated nameplate voltage across each phase. There should be no more than 2% variation between the average voltage and each leg.
 - 3) The amp reading of each phase should be less than the rated nameplate amps.
 - 4) Observe the unit for proper pressure and flow output.
 - 5) Continue to observe the unit's operation for at least the next four hours.
 - F. For any problems, consult the "Troubleshooting" section of this manual.

5430, 5730, 2430 WD

- A. The pump must be primed to initial start up and the prime must be maintained through subsequent start-stop cycles. The priming procedure is different for positive and negative suction head systems and the following procedures should be followed:
 1. Positive suction head:
 - a. open vent on the highest point on the pump casing.
 - b. open all suction valves.
 - c. allow the liquid to flow from the vent hole until all air bubbles are vented, then close the vent.
 2. Negative suction head:
 - a. install an ejector or vacuum pump on the vent on the highest point on the pump casing.
 - b. open the suction valve.
 - c. start ejector or vacuum pump.
 - d. allow liquid to flow until a continuous flow is exhausted from the ejector, then close the valve to the vent.
- B. Refer to the motor nameplate for operation limits before proceeding.

- C. The motor requires no special procedures or adjustments before starting, except to check for rotation. The control system should be set to ensure no more than 10 across the line starts per hour on the 210 through 365 frame motors, and 1 across the line start per hour on the 400 frame and larger motors.

 **WARNING**

- **Under no circumstances should any flammable liquids be pumped.**
- D. For motors with water jackets that utilize an external water source, ensure water is flowing to the water jacket. Refer to the Technical Data section for cooling water flow requirements.
- E. After the pump is primed and the external cooling water is running, if required, start the unit.
- F. Immediately after the unit has started, check the following:
- 1) Observe the unit for any unusual noise or vibration.
 - 2) The voltage should be within +/- 10% of the rated nameplate voltage across each phase. There should be no more than 2% variation between the average voltage and each leg.
 - 3) The amp reading of each phase should be less than the rated nameplate amps.
 - 4) Observe the unit for proper pressure and flow output.
 - 5) Continue to observe the unit's operation for at least the next four hours.
- G. For any problems, consult the "Troubleshooting" section of this manual.

Stopping the Pump

Pump stations are usually designed to have the pumps started and stopped automatically. Since this is a function of station design, the operators should be familiar with the systems operating parameters. The general procedure to shut down the pump is as follows:

- A. Disconnect the electrical motor.
- B. If the pump is to be removed for repair, close the suction and discharge valves.

Seasonal Operating Instructions

If the pump is located in an area that is subject to below freezing temperatures and will not be operated enough to prevent freezing, it should be drained to prevent damage to the casing caused by freezing. Particular attention should be made to jacketed units using an external water source.

Emergency Procedures

Many installations are equipped with emergency shut off switches near the pump location. These locations should be plainly marked and be readily accessible at all times.

The control panel (if used) may be equipped with an emergency start/stop button or switch.

IMPORTANT

- **The operator or persons working around the equipment should be familiar with locations of emergency start-up and shut-off points.**

TROUBLESHOOTING

If you have followed the installation and start up procedures outlined in this manual, your pump should provide reliable service and long life. However, if operating problems occur, significant time and expense can be saved if you use the following checklist to eliminate the most common causes of those problems.

Insufficient Pressure or Flow	
Cause	Remedy
1. Wrong direction of rotation.	Reverse any two motor lead connections. Check O&M manual.
2. Impeller running clearance too great.	Reset impeller clearance per O&M manual.
3. Speed too low.	Check driver voltage and electrical source.
4. Impeller passage partially plugged.	Clean impeller passages.
5. Insufficient net positive suction head.	Raise wet well level.
6. Air in liquid.	De-aerate liquid. Increase submergence to prevent vortexing.
7. Impeller damaged.	Check and repair or replace.
8. Impeller diameter too small.	Replace impeller with larger diameter. Check driver HP.
The following for "WD" Models only.	
9. Suction lift too high.	Reduce suction line losses.
10. Insufficient suction line submergence.	Increase submergence.
11. Air leaks into suction piping or gaskets.	Check flange connections for proper seal. Tighten connections.

Excessive Power Consumption	
Cause	Remedy
1. Pump too much liquid.	Change system. Reduce pump speed. Trim impeller.
2. Speed too high.	Check driver speed and voltage.
3. Improper line voltage or frequency.	Check driver voltage. Change power source or driver.
4. Incorrect diameter impeller.	Determine correct impeller diameter and replace or trim impeller.
5. Shaft bent.	Replace shaft.
6. Specific gravity or viscosity of liquid pumped is too high.	Reduce pump capacity.

Vibration or Noise	
Cause	Remedy
1. Pipe strain.	Improperly supported or aligned. Check pipe supports adjust or realign.
2. Wrong rotation.	Reverse any two motor lead connections. Check O&M manual.
3. Pumps too much liquid and exceeds NPSHR.	Increase system head. Reduce pump speed. Trim impeller.
4. Shaft bent.	Replace shaft.
5. Pump running at shut-off position.	Open discharge valve. Check for obstructions.
6. Air in liquid.	Increase submergence.
7. Impeller passages plugged.	Clean impeller passages.

Overheating	
Symptom	Remedy
1. Shaft bent.	Replace shaft.
2. Insufficient submergence.	Increase submergence.
3. Rotating element binds.	Determine cause and correct.
4. Water cooling line plugged. (External water source only.)	Clean cooling water line. Provide clean source of liquid.
5. Water jacket passageways restricted.	Clean water jacket.
6. Excessive load.	Increase system head. Check for mechanical interference.
7. Excessive cycles.	Change level controls, change system.
8. Excessively high or low voltage.	Correct voltage source.

Liquid Level Above High Limit	
Cause	Remedy
1. Excessive flow to wet well.	Reduce influent. Increase pump capacity.
2. Solids collecting around the pump suction reducing pump capacity.	Remove solids accumulation.
3. Controls improperly set on the high level.	Reset controls.
4. Improper sump design.	Correct sump design.
5. Pump has been inoperative temporarily and excess water has accumulated in wet well.	Operate pump to reduce level. (If a higher than normal water level has existed and was not witnessed, it can easily be detected by examining the sump for a scum line above the normal high level limit.)

MAINTENANCE

General

- A. With proper application of the pump/motor unit and proper installation of all the protective devices, no periodic maintenance of the equipment is necessary.
- B. Should the moisture detector indicate intrusion of moisture, the pump should be shut-down as soon as possible. Oil should be drained from the motor by removing the oil cavity inspection plug. With the motor in position with the inspection plug hole at the top, refill the seal chamber with oil (refer to the oil capacity table on page 38 of this manual) and place the unit back in service. (In some cases, the seal faces require time to seal properly and some water may have passed by the seal faces into the seal oil chamber causing an alarm to signal.)

Note that all mechanical seals must seep to provide lubrication to the rotating faces. This is trapped in the oil chamber between the inner and outer seals. During the initial run-in period, new seals may seep enough to cause the moisture alarm to go off. This is normal, change the oil and put the unit back into service.

- C. Should a malfunction be indicated by the motor protection devices or observed in the operation of the pump, the pump should be removed and serviced and the cause of the problem corrected. Refer to the **REPAIR PARTS** section of this manual for instructions on ordering.
- D. Motor overheating may be caused by an accumulation of foreign material collecting on the outside of the motor housing. For non-jacketed motors, the outside of the motor housing should be cleaned. In the case of jacketed motors, it may also be necessary to wash the internal and external surfaces of the cooling jacket and the stand pipe tube (71D) per the following instructions.

The water jacket is supplied with two taps, one labeled “in” and the second “out.” Before removing the jacket for cleaning, try cleaning out the cooling cavity by flushing water through the “out” tap and out the “in” tap. Reinstall the unit and test for overheating by running the unit.

Pump Disassembly

WARNING

- **Read this entire disassembly procedure and refer to the sectional drawings in this manual before starting.**

A. Prepare the pump for disassembly according to the following procedures:

1. Disconnect and lock out the power to the motor.

 **DANGER**

- **Check with appropriate electrical test equipment to ensure the motor cannot be accidentally started.**
 2. Remove the pump and motor from the sump.
 3. If pump/motor inspection, maintenance or repair must be performed at another location, disconnect the motor leads at the controller.
- B. Remove the capscrews holding the motor to the volute.
 1. Remove the motor and impeller assembly from the volute.
 2. Store the motor in a clean, dry place if no motor repair is required.
- C. Remove the impeller capscrew (9) and impeller washer (9A). Because the impeller capscrew (9) is installed with Loctite, it may be necessary to heat the capscrew to break the bond. Excessive heating may damage the lower seal.

 **WARNING**

- **To prevent possible serious personal injury, heat resistant gloves must be worn when handling heated parts.**
- D. Remove the impeller (1) and the impeller key (102) from the motor shaft.
 1. The impeller (1) has a straight bore fit, with a close tolerance. It may be necessary to use a wheel puller or similar device.
 2. Note the location and number of shims placed between the impeller hub (or circulator if provided) and the shaft shoulder.

IMPORTANT

- **Care should be taken not to damage the impeller when using a puller or similar device. Attach the puller or other equipment at the impeller vane area only, do not use the impeller shroud.**

IMPORTANT

- **Do not try to remove the shaft from the motor or disassemble any part of the motor.**
- E. If the impeller or fronthead wear rings require replacement, or if the pump is to be retrofitted for wear rings, refer to the **WEAR RINGS** section of this manual. Always use genuine **Fairbanks Nijhuis™** parts.

Note: It is not necessary to remove the volute (30) from the fronthead (33) unless those items require service.
- F. If the fronthead (33) must be removed, remove the capscrews and remove from the volute (30). Remove the cleanout over (202) and gasket (203), if provided.

Motor Disassembly

The motor requires no periodic service, with the exception of changing the mechanical seal oil every 4000 hours of operation, not to exceed one year. Motor bearings are lubricated for life.

A. Cover/Cable Removal

1. With the motor in a vertical position remove the cover capscrews, loosening slowly to allow any pressure to escape.
2. Break the seal between the cover and the housing.
3. Lift cover, turn over, and secure to housing with one cover capscrew.
4. Remove the terminal board nuts and lead wires.

B.

1. Drain oil from seal chamber through the inspection plug (34G), and properly dispose of oil.
2. Remove the seal retaining ring (4G).
3. Remove the seal protective cup, seal spring retainer and spring.
4. Remove the rotating portion of the seal.
5. Remove the gland capscrews (31A).
6. Remove the gland (31).
7. Remove stationary portion of seal from the gland.

- C. On the 250 frame motors, first remove the Water Jacket Retaining Ring (71A) by spreading it with a blunt screwdriver. On 320 and larger frame motors, remove the jacket capscrews (71F) and retainers (71E). Match-mark the water jacket and motor. Remove the jacket by tapping on the lugs at the bottom end of the jacket. Flush the outside of the motor. Remove both O-Rings (71B) and (71C) and clean the O-Ring grooves. Check and clean the cooling water inlet and outlet passages from any obstructions. Pay particular attention to cleaning of the stand pipe tubes (71D). If necessary, remove the motor from the volute to inspect and clean the Water Circulator (39), and the water channels in the back of it. Flush and clean the water jacket.

For reassembly, proceed in the reverse order. Installation of new O-Rings (71B) and (71C) is recommended after each disassembly. Realign the water jacket and motor to the match-mark(s), by rotation of the jacket in a counter-clockwise direction.

CAUTION

- **Never attempt to disassemble the motor without first allowing it to cool down. Residual heat in the motor windings can cause high temperatures and pressures within the motor. Escaping hot gas or oil may cause serious personal injury.**

Motor Assembly

WARNING

- **Read this entire assembly procedure before starting.**

A. Outer Mechanical Seal and Gland Installation

1. Inspect the shaft.
2. Buff out all nicks that could cut the seal elastomer.

IMPORTANT

- **Caution must be exercised while buffing to avoid creating flat spots on the shaft under the elastomer. Wipe the shaft clean with a soft cloth. Keep the material out of the oil cavity.**
3. Clean the machined surfaces.
 4. Clean the oil cavity and replace the inspection plug.

5. Fill the moisture detection cavity (cavity around the inner seal) with oil according to the table on page 38 of this manual.
 6. Install the gland O-Ring (31B) on the gland (31).
 7. Run a small bead of 525 Loctite® Form-a-Gasket around the face of the lower bearing housing (34).
 8. Install the gland and bolt together.
 9. Lubricate the rubber component of the stationary part of the seal with a water base rubber lubricant (Pac-Ease or equal) and install it into the gland.
 10. Lubricate the inner diameter of the rubber boot on the rotating portion of the seal with Pac-Ease (or equal) water base rubber lubricant.
 11. Install rotating portion of the seal. Be sure not to damage the seal while it passes over the step on the shaft. Take care passing the seal over the retaining ring groove. Be sure not to touch the face of the seal.
 12. Install the seal spring, seal protective cup and outer mechanical seal retaining ring, (4G) compressing the spring until the retaining ring seats into its groove.
- B. Cover Cable Assembly
1. Install the cover O-Ring (32A) onto the cover.
 2. Connect the control and power cable lead wires to the terminal board as shown on the drawings in the Auxiliary Diagrams section of this manual.
 3. Run a small bead of 525 Loctite® Form-a-Gasket around the motor housing (90) or to the top motor housing (on 320 and 360 frames) to seal it to the cover.
 4. Place the cover onto the motor housing or top motor housing and bolt up.

Pump Assembly



- **Read this entire assembly procedure before starting.**

The following step-by-step instructions for assembly of the pump are essentially the reverse order of the instructions for disassembly.

- A. Prepare the pump for assembly according to the following procedures:
1. Thoroughly clean all parts to remove all oil, grease and any foreign material.
 2. Inspect all parts including the motor shaft for wear or damage and replace if required.
 3. Gaskets should not be reused and should always be replaced.
- B. If the impeller or fronthead wear rings are being replaced, or if the pump is to be retrofitted for wear rings, refer to the **Wear Rings** section of this manual. Always use **Fairbanks Nijhuis™** parts.

C. Thoroughly clean the impeller bore, the end of the shaft, the shaft and keyway.

1. Inspect and measure the impeller bore, the shaft fit diameter, the key and the keyway for wear.

Note: Measure in several locations along the length of the fit.

2. If wear is noticed and the clearance between the shaft and the impeller (1) exceeds 0.003" anywhere along the length of the impeller bore, contact the factory for instructions for rework or replacement of the components.
3. Install the impeller key (102) in the motor shaft. Replace the shaft shims and if provided the circulator. Slide the impeller (1) in place, making sure it butts firmly against the shaft shims or circulator.
4. With the impeller washer (9A) in place, install the impeller capscrew (9) and tighten securely. (Refer to the Technical Data section for torquing values.)

D. If the volute (30) and fronthead (33) have been removed proceed as follows:

1. Use new cleanout cover gaskets (203) and install the cleanout cover (202), if provided.
2. Install a new volute gasket (156) and install the fronthead (33) on the volute (30) and secure with capscrews.

E. Install the motor with impeller in the volute (30) and securely tighten the capscrews holding the motor to the volute (30).

F. Check the impeller/fronthead clearance as follows:

1. Measure the clearance between the impeller face and the suction head and record this value.
2. If the clearance is not between the values shown below, remove the impeller and shim between the impeller hub and shaft until the proper clearance is obtained.

Pump	Nominal Clearance
2" thru 5" 5431-5434	.010 - .020
4" 5435	.0075 - .015
6" and 8" 5413-5415	.015 - .025
10" 5435	.020 - .030
5" thru 8" 5436	.020 - .030
All 5700 Series	.030 - .040
All 2400 Series	.025 - .035

G. After the proper clearance has been obtained remove the impeller capscrew.

1. Apply 3 or 4 drops of Loctite® No. 609 to the capscrew threads.
2. With the impeller washer (9A) in place, install the capscrew (9) and torque to the values shown in the Technical Data section of this manual.

IMPORTANT

- **This capscrew torque value is for SAE grade 8 steel capscrews only. If other material is used, consult with the Fairbanks Nijhuis™ engineering department for proper torque values.**

H. Install the motor/impeller assembly in the volute and tighten the capscrews.

Note: Allow the Loctite® to cure before starting the pump.

I. The pump assembly is complete.

J. Return the unit to the sump and resume operation.

Wear Rings

Replacing Existing Wear Rings

If the pump is equipped with wear rings and replacement is required, refer to Wear Ring Removal below.

If this pump is to be fitted with wear rings, and was not originally so equipped, contact the factory for correct dimensions.

CAUTION

- **Machine work should be done by a qualified machinist experienced in similar machining work.**

WARNING

- **To prevent possible serious personal injury, heat resistant gloves must be worn when handling heated parts.**
- **To prevent possible serious personal injury, protective eye glasses should be worn while working on this equipment.**

Wear Ring Removal

If the wear ring requires replacement it can be removed by heating it to 350-400°F to break the Loctite® bond.

Wear Ring Installation

If the wear rings are to be replaced they should be replaced with genuine Fairbanks Nijhuis™ wear rings. Install the wear rings as follows:

- A. Apply a bead of Loctite® No. 290 completely around the middle of the impeller wear ring (17) and fronthead wear ring (16) fit, and press the wear rings into place.

IMPORTANT

- **To ensure proper bonding, thoroughly clean all mating parts with solvent to remove all grease, oil, dirt, etc.**
- **To avoid distortion and ensure proper installation, be careful to press the wear rings evenly and completely in place. They should be firmly butted against the corresponding impeller or fronthead shoulder at the bottom of the wear ring fit.**

REPAIR PARTS

Ordering Parts

When ordering parts, give the pump serial number, figure number, and a complete description and item number of each part. Refer to the drawing and parts list located in this manual. You may order parts from your local Fairbanks Nijhuis™ distributor. Consult your local telephone yellow pages under “pumps” for the office nearest you.

You may also order parts directly from the factory as follows:

Fairbanks Nijhuis
3601 Fairbanks Avenue
Kansas City, KS 66106
913/371-5000
Fax 800/848-3696

Returning Parts

All materials or parts returned to the factory must have prior approval and a “Returned Goods Tag,” listing the material to be returned and the reasons for the return. All material to be returned should be carefully packed to avoid damage in route from rough handling or exposure to weather. Contact the factory for shipping instructions. All material is to be returned freight prepaid.

Fairbanks Nijhuis makes improvements on its products from time to time, and reserves the right to furnish improved parts for repairs. A part that is received and is not identical in appearance, or has a different symbol from the original part, may be interchangeable. Examine the part carefully before contacting your Fairbanks Nijhuis representative. The parts should never be returned to the factory without first obtaining proper authorization from your Fairbanks Nijhuis representative.

SERVICE

Warranty Service

For Warranty Service contact the factory at:

Fairbanks Nijhuis
3601 Fairbanks Avenue
Kansas City, KS 66106
913/371-5000
Fax 877/417-1777

Service After Warranty

For service after warranty on this pump, or any other pumping equipment, contact:

Pump Services Group – 1-800-648-PUMP

Or write:

Pump Services Group
Fairbanks Nijhuis
3601 Fairbanks Avenue
Kansas City, KS 66106
913/371-5000
Fax 913/371-0515

TECHNICAL DATA

Pump Size/Model	Motor Frame	Approx Weight	Impeller Capscrew Torque Values (Foot-Pounds)
4" D5431	210	625	60
2" D5432	210	630	60
3" D5432	210	650	60
4" D5432 MV	210	670	60
	250	700	60
4" D5432	210	660	60
	250	690	60
3" D5433	210	950	60
	250	1180	60
4" D5433	210	770	60
	250	1200	60
4" D5433 MV	320	1500	200
	210	750	60
	250	1180	60
5" D5433	320	1480	200
	210	925	60
	250	1350	60
6" D5433	320	1650	200
	250	1400	60
	320	1700	200
6" D5433 MV	250	1375	60
	320	1675	200
4" D5434	250	1750	60
	320	2060	200
5" D5434	360	2060	300
	250	1890	60
	320	2170	200
6" D5434	250	1975	60
	320	2290	200
6" D5434 MV	250	1950	60
	320	2260	200
8" D5434 S	250	2050	60
	320	2430	200
8" D5434 SMV	250	2025	60
	320	2410	200
8" D5434 L	250	2100	60
	320	2480	200
8" D5434 LMV	250	2075	60
	320	2460	200
4" D5435	210	1450	60
	250	1850	60
4" D5435 MV	320	2150	200
	210	1425	60
	250	1825	60
8" D5435	320	2125	200
	320	2690	200
	360	2890	300
8" D5435 MV	440	5700	300
	320	2630	200
	360	2860	300
	440	5670	300
10" D5435	360	2960	300
	440	5900	300
10" D5435 MV	360	2930	300
	440	5870	300

Pump Size/Model	Motor Frame	Approx Weight	Impeller Capscrew Torque Values (Foot-Pounds)
5" D5436	250	1925	60
	320	2475	200
5" D5436 MV	250	1925	60
	320	2475	200
	360	2700	300
6" D5436L	360	2700	300
	250	2025	60
	320	2575	200
8" D5436	360	2825	300
	440	5150	300
	360	2775	300
	440	5700	300
8" D5436 MV	360	2725	300
	440	5670	300
12" 2434	360	RTF	
	365	RTF	
12" 2435	400	RTF	
	440	RTF	
	360	RTF	
	365	RTF	
12" 2436	400	RTF	
	440	RTF	
	360	RTF	
	364	RTF	
16" 2434 16" 2435	400	RTF	
	440	RTF	
	440	RTF	
16" 2436	440	RTF	
12" 5731	250	2200	
	320	3440	
14" 5731	360	3200	
	320	3275	
	360	3755	
12" 5731 MV	364	3755	
	400	6710	
	440	6710	
	250	2875	
	320	3440	
14" 5731 MV	360	3920	
	320	4210	
	360	4690	
	365	4750	
	400	7145	
16" 5731 MV	440	7145	
16" 5731 MV	440	RTF	
20" 5731 MV	440	RTF	
14" 5732 MV	490	RTF	
14" 5732 W	490	RTF	
14" 5733 MV	490	RTF	
20" 5731 MV	490	RTF	
24" 5731 MV	490	RTF	

Moisture Detection Cavity Oil Capacities

Frame Size	One Port Capacity	Two or Three Port Capacity
210	19 oz.	28 oz.
250	22 oz.	38 oz.
320	52 oz.	74 oz.
360	48 oz.	71 oz.
365	N/A	71 oz.
400	N/A	71 oz.
440	N/A	62 oz.
490	N/A	174 oz.

External Cooling Water Requirements

Frame Size	Flow Rate (1)
250	3 GPM
320	6 GPM
360	10 GPM
365	10 GPM
400	15 GPM
440	25 GPM
490	30 GPM

Seal Oil

Manufacturer		Description
Primary	Texaco	Cygnus Hydraulic Oil 32
Alternate	Amoco	5NF White Mineral Oil
Alternate	Texaco	Texpar 13
Alternate	Mobile	Whiterex 425
Alternate	Atlantic Richfield	Arcoprine Oil 90
Alternate	Lyondell Petrochemical	Alpha Pac Oil 90
Alternate	Chevron	Lubricating Oil FM ISO 32

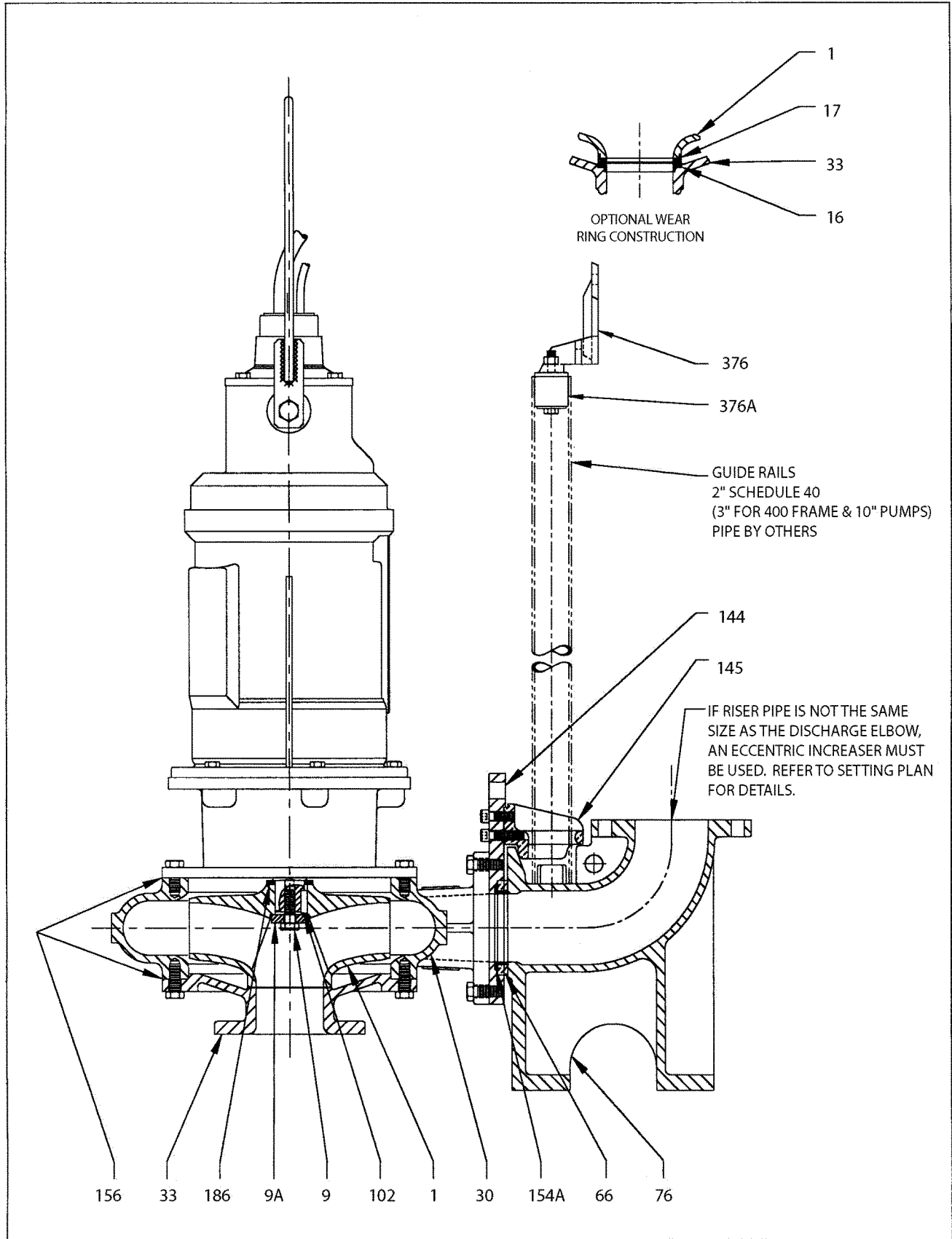

ASSEMBLY, D5430MT, PULL-UP SUBMERSIBLE
 THRU 365 FRAME FAIRBANKS NIJHUIS MOTOR

PENTAIR FAIRBANKS NIJHUIS™	
DWG NO 543MA101	REV NO 4

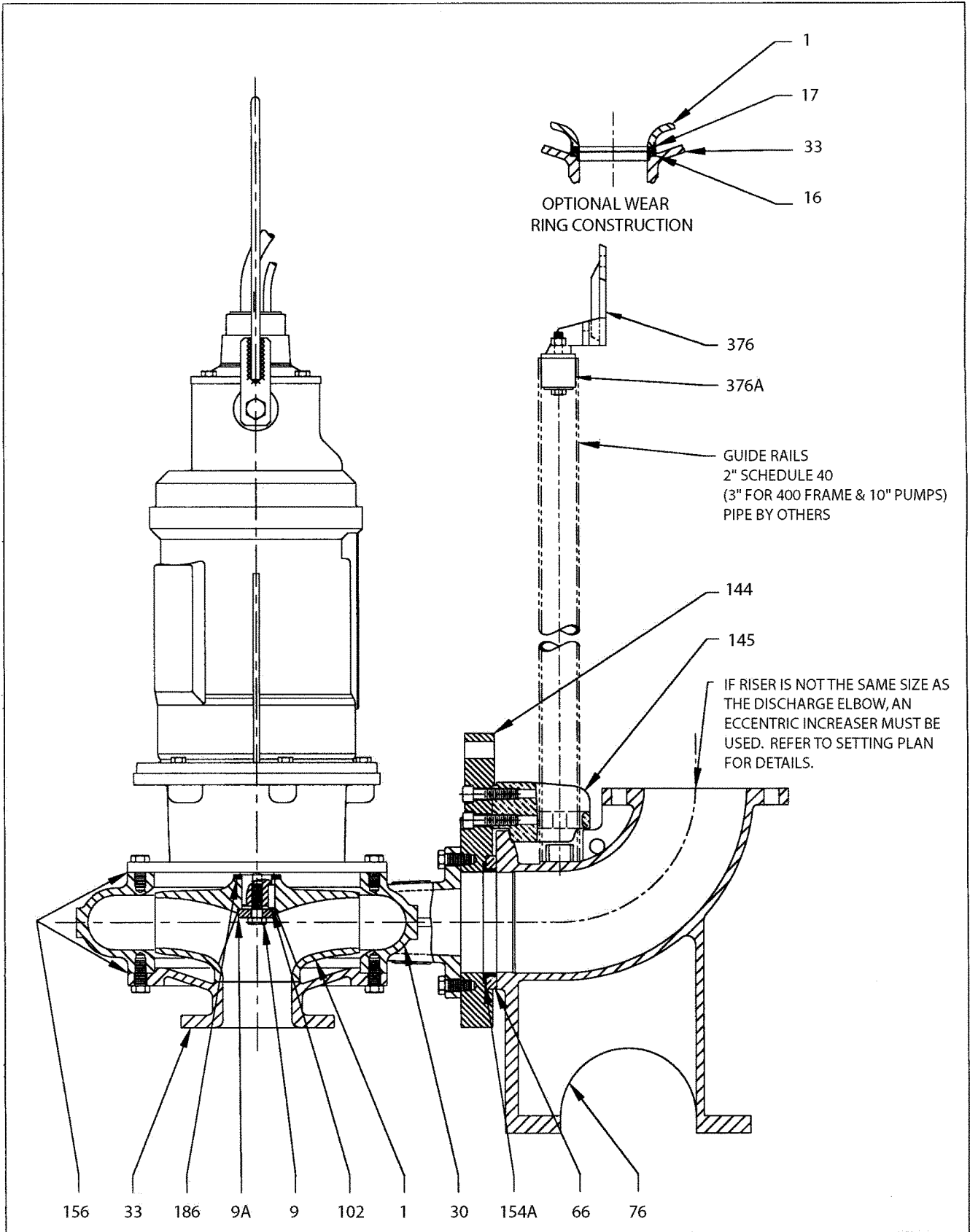

ASSEMBLY, D5430MT, PULL-UP SUBMERSIBLE
THRU 365 FRAME, SIZE LARGER ELOBW, F.N. MOTOR

PENTAIR FAIRBANKS NIJHUIS

DWG NO	543MA107	REV NO	1
--------	----------	--------	---

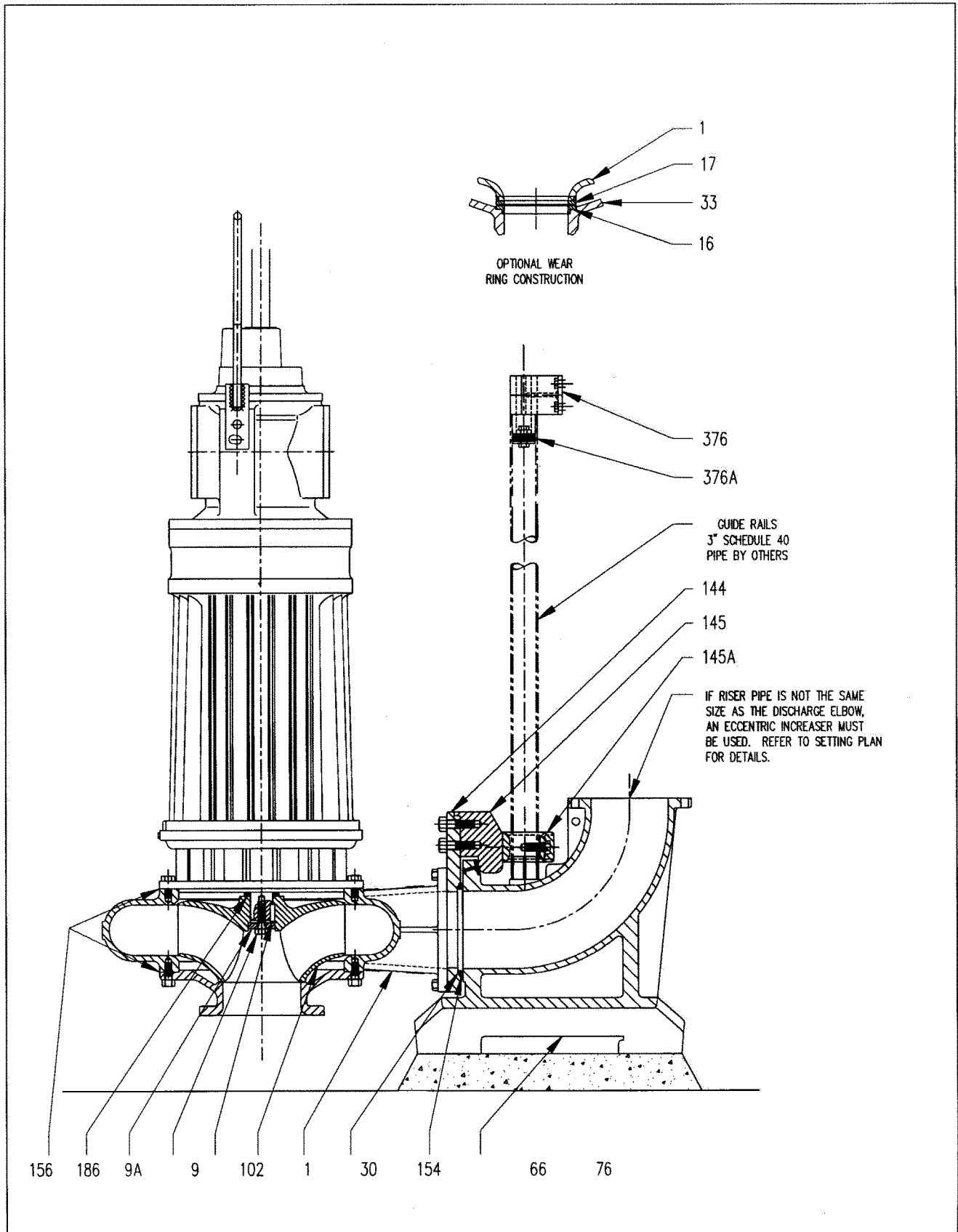

ASSEMBLY, D5430MT, PULL-UP SUBMERSIBLE
 400, 440 & 490 FRAME FAIRBANKS NIJHUIS MOTOR

PENTAIR FAIRBANKS NIJHUIS™	
DWG NO 543MA102	REV NO 5

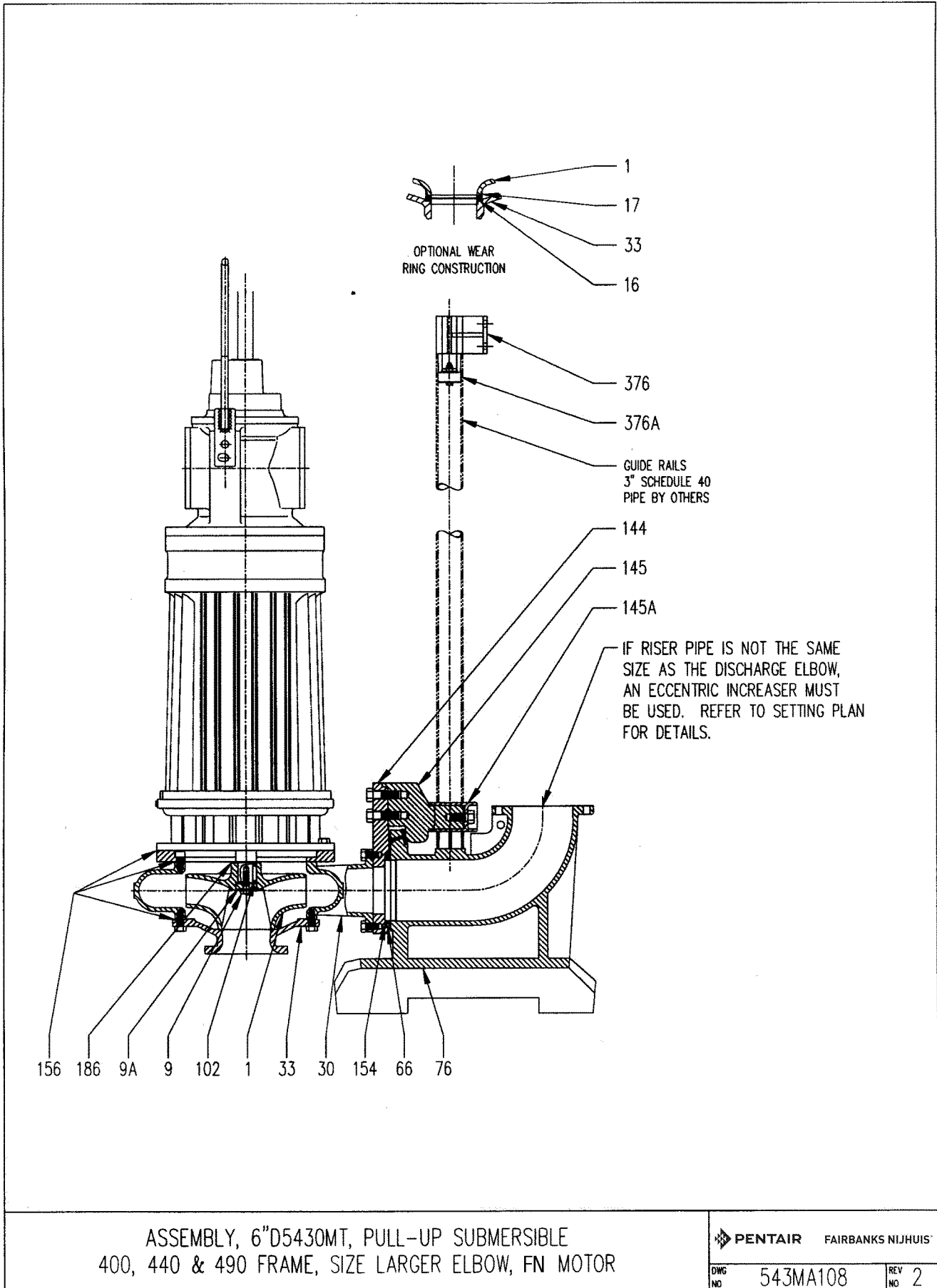

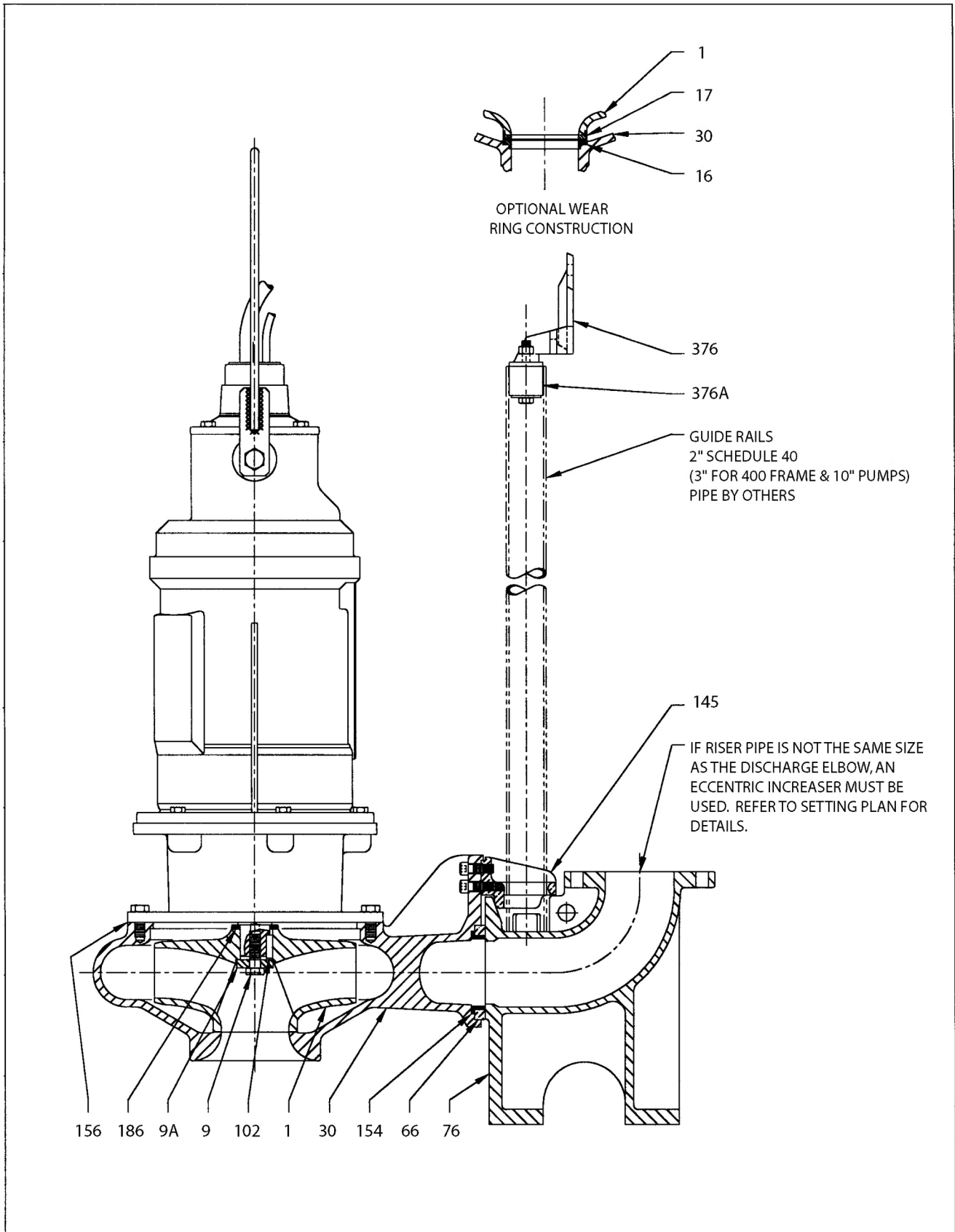

ASSEMBLY, D5430MV, PULL-UP SUBMERSIBLE
 THRU 365 FRAME, FAIRBANKS NIJHUIS MOTOR

PENTAIR FAIRBANKS NIJHUIS™	
DWG NO 543MA005	REV NO 3

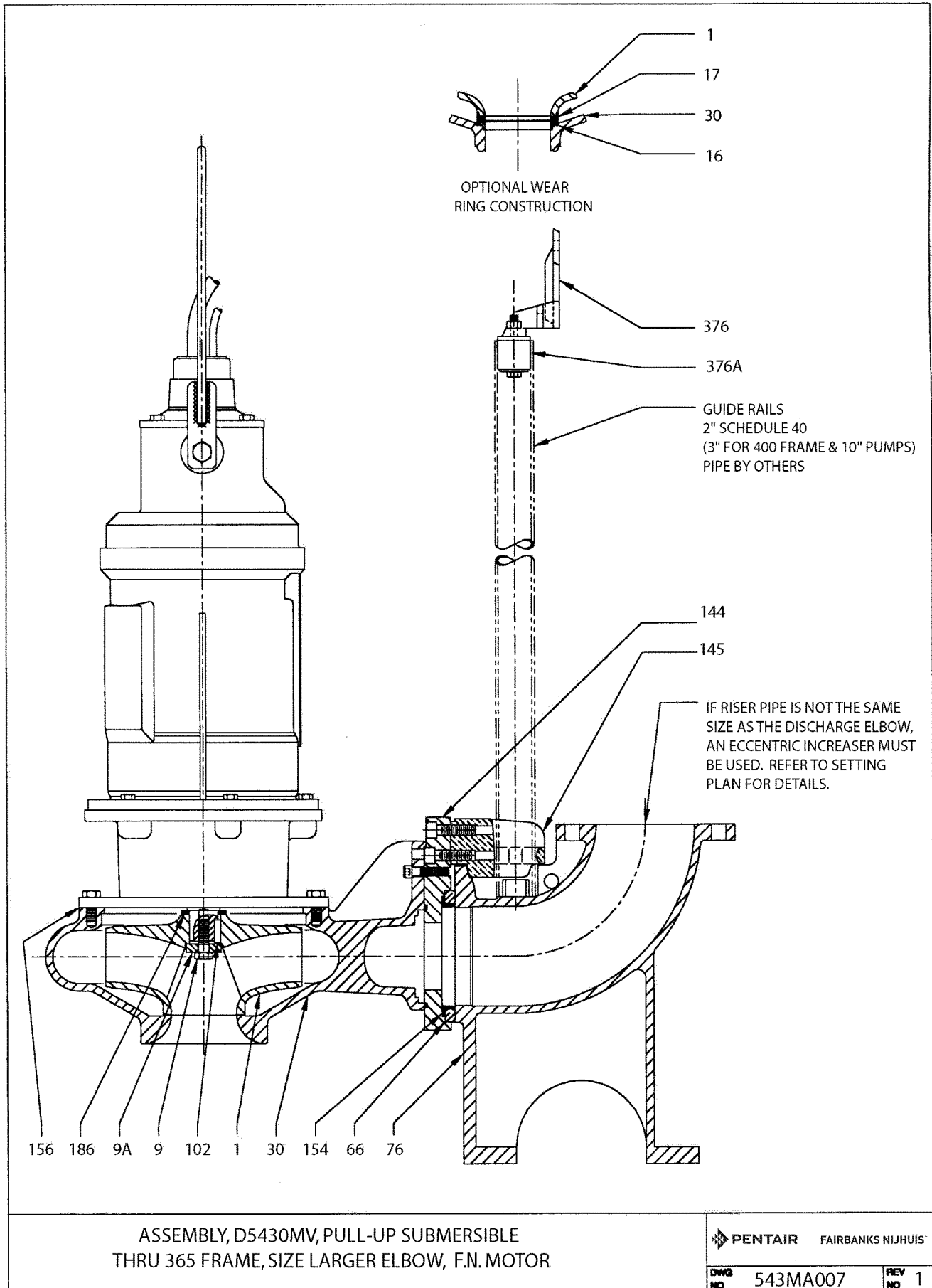

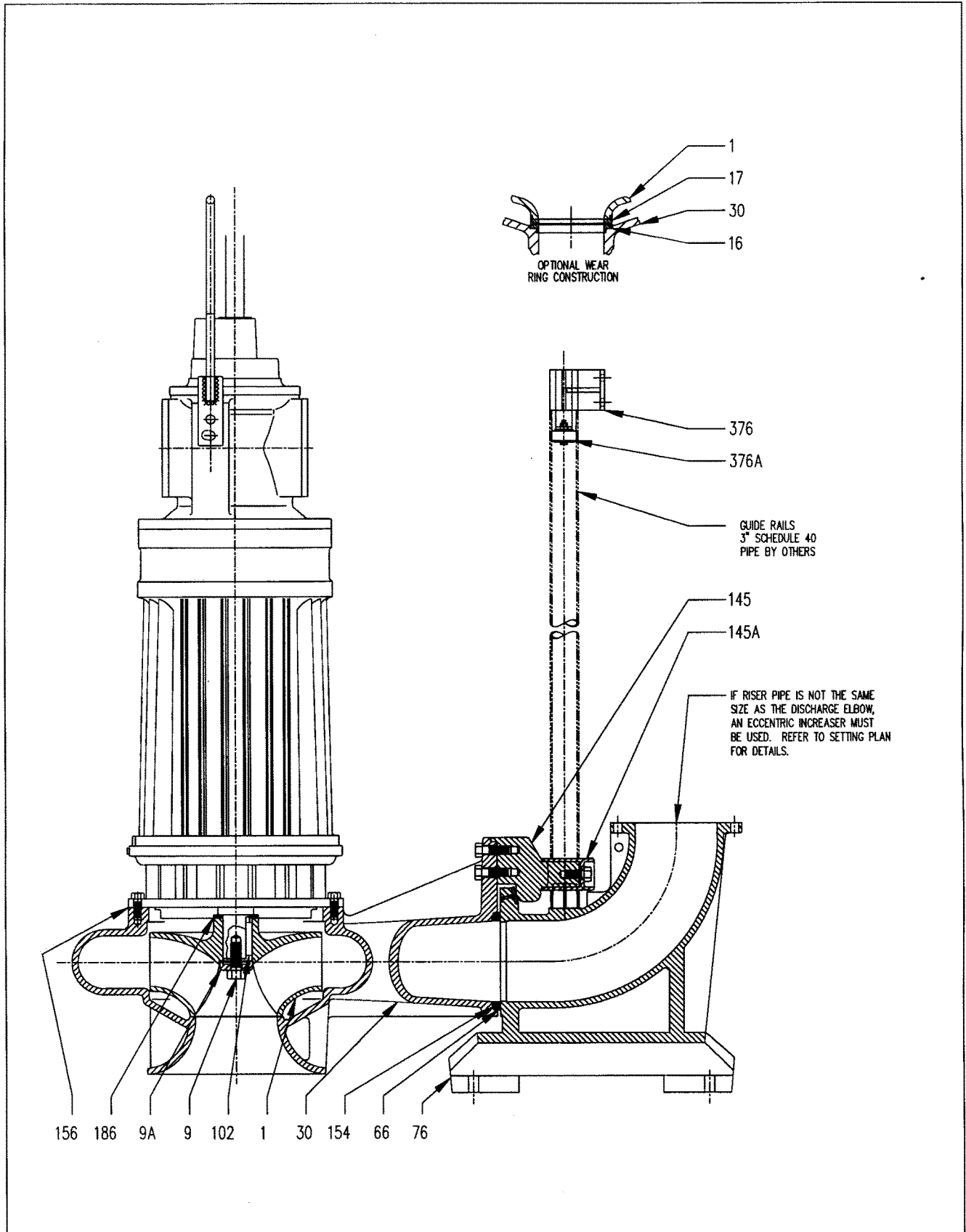

ASSEMBLY, D5430MV, PULL-UP SUBMERSIBLE
 400, 440 & 490 FRAME FAIRBANKS NIJHUIS MOTOR

PENTAIR FAIRBANKS NIJHUIS™

DWG NO 543MA006 REV NO 2

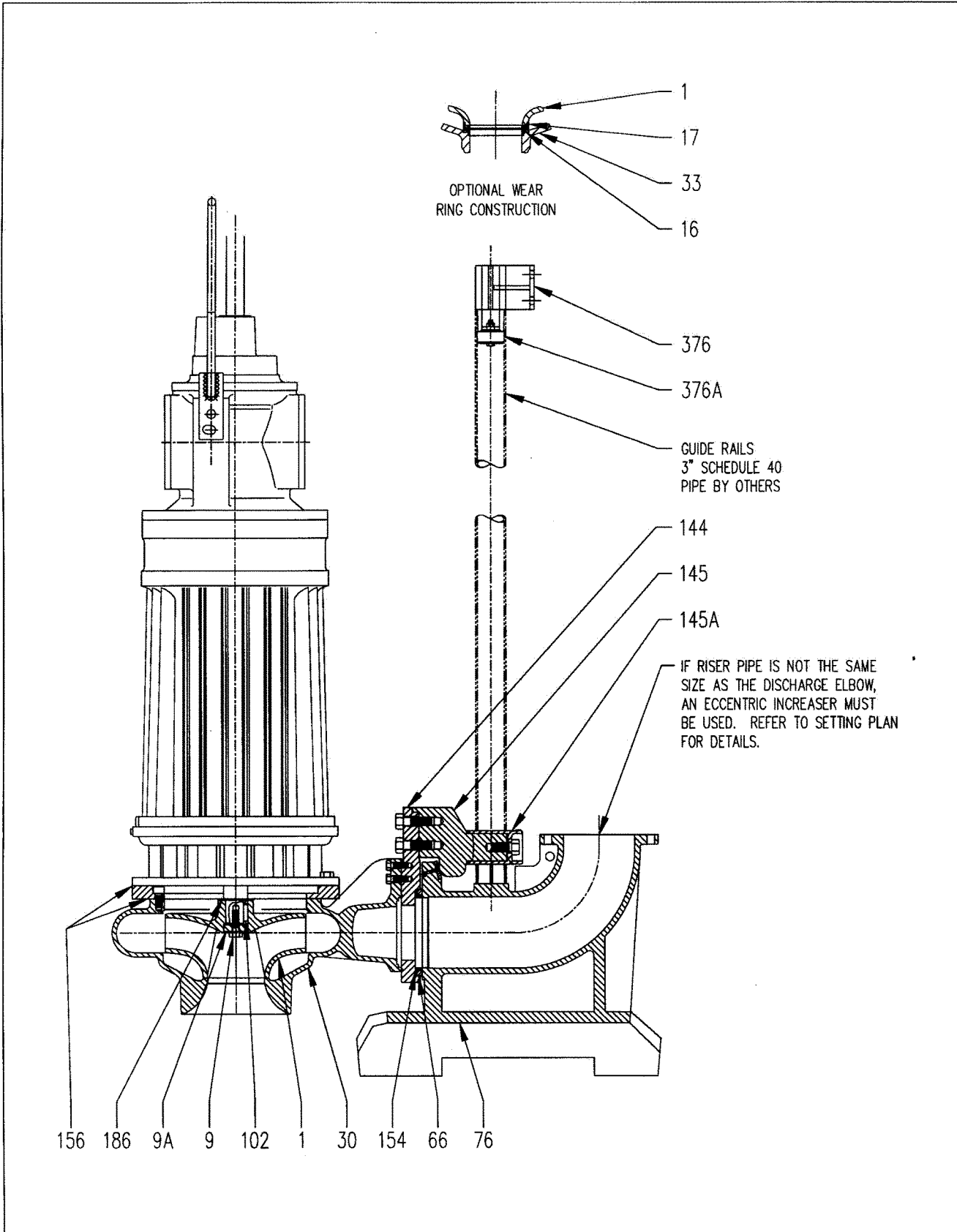

ASSEMBLY, 6" D5430MV, PULL-UP SUBMERSIBLE, 400,
440 & 490 FRAME, SIZE LARGER ELBOW, FN MOTOR

PENTAIR FAIRBANKS NIJHUIS	
DWG NO	543MA008
REV NO	2

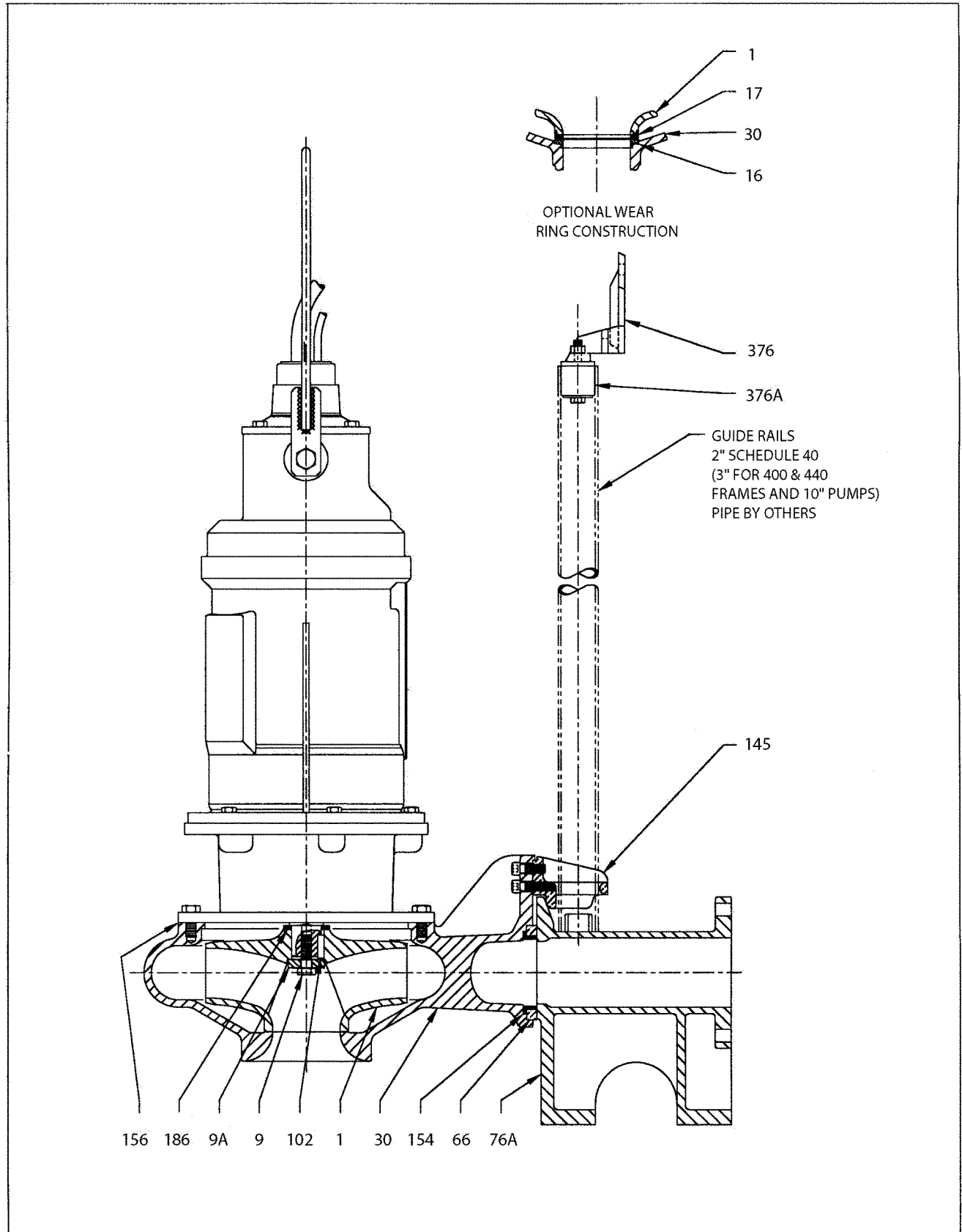

ASSEMBLY, D5430MVS, PULL-UP SUBMERSIBLE
 STRAIGHT THRU DISCHARGE

PENTAIR FAIRBANKS NIJHUIS™	
DWG NO 543MA103	REV NO 0

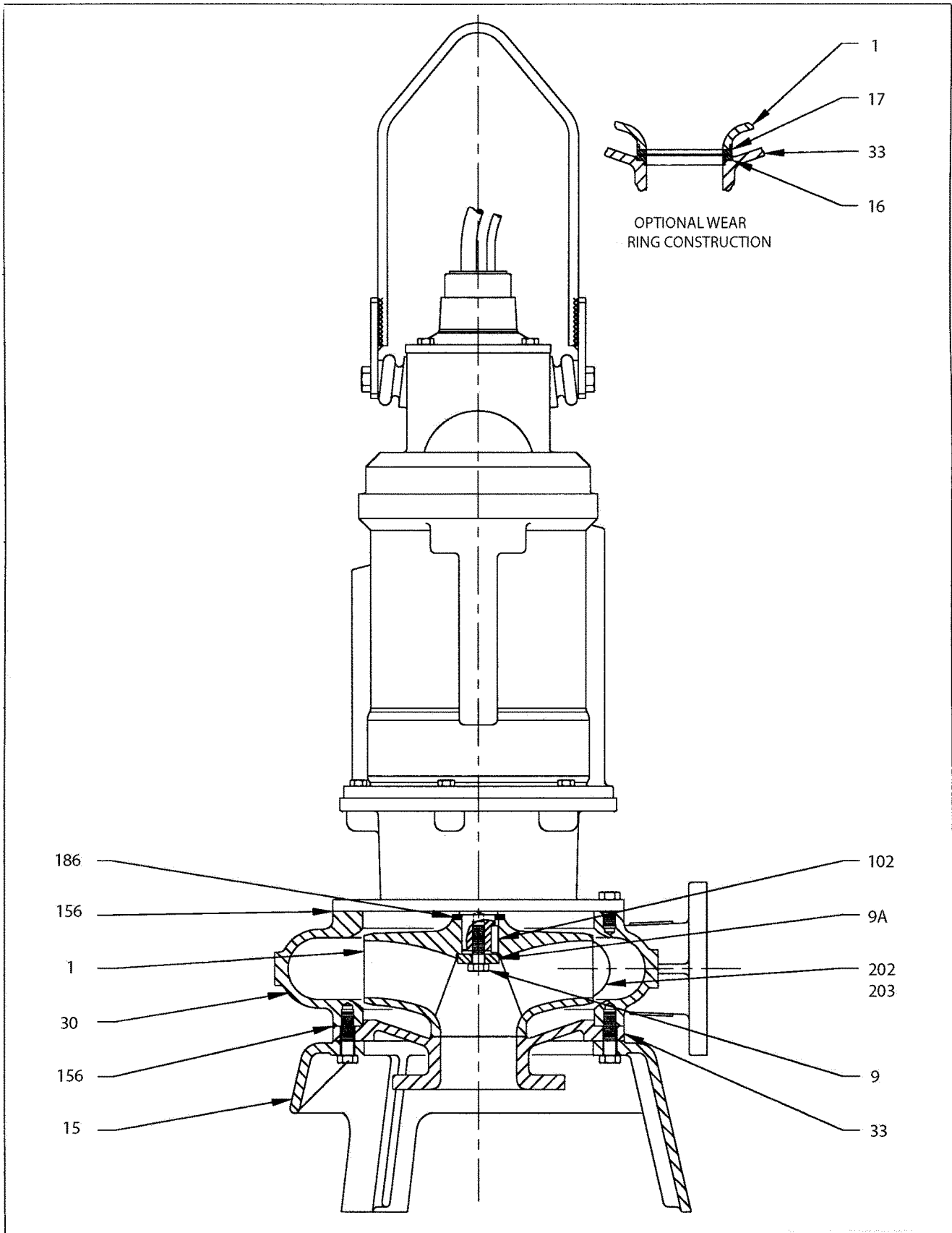

ASSEMBLY, D5430W, SUBMERSIBLE
FAIRBANKS NIJHUIS MOTOR

PENTAIR		FAIRBANKS NIJHUIS
DWG NO	543WA001	REV NO 1

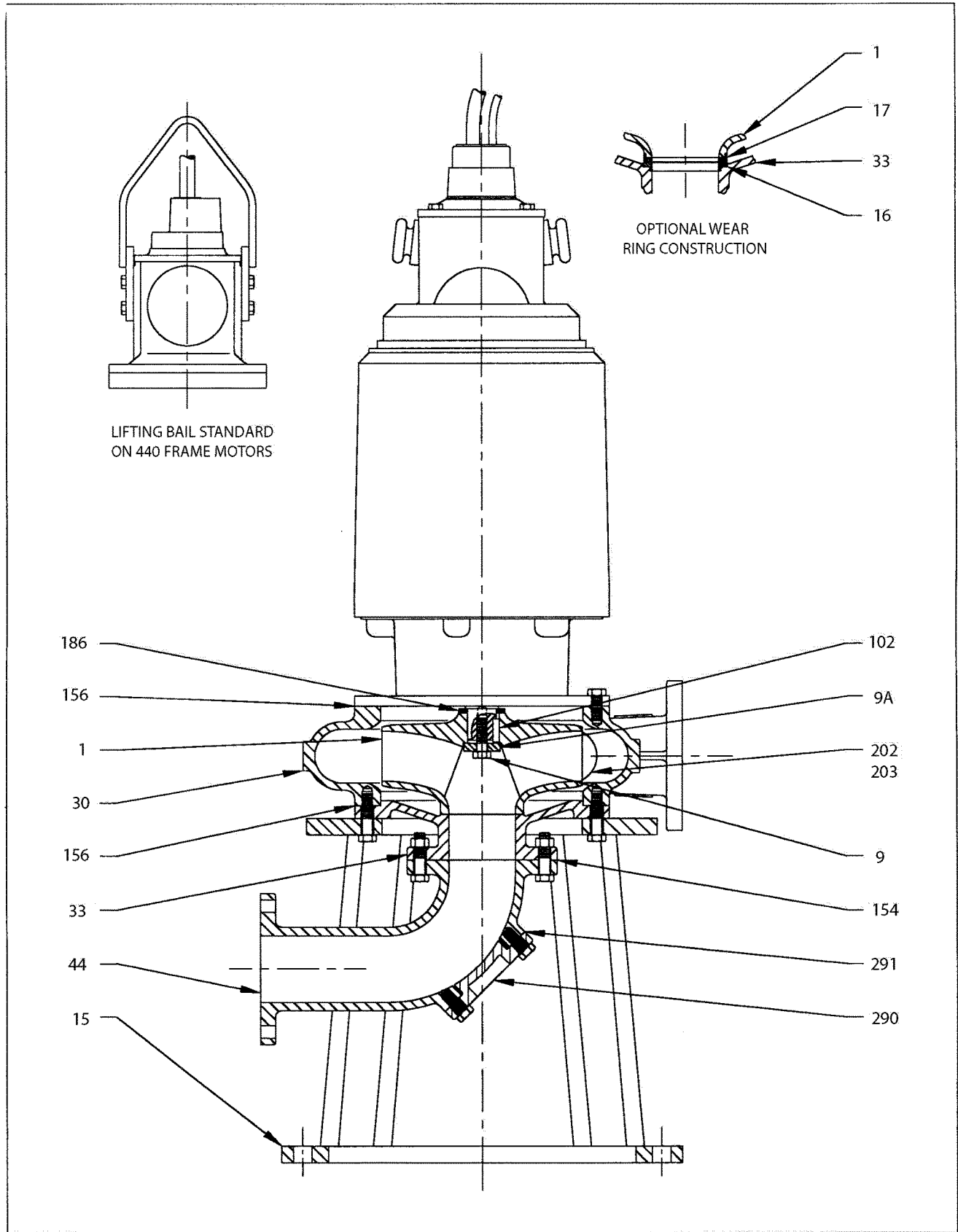

ASSEMBLY, D5439WD, SUBMERSIBLE
 FAIRBANKS NIJHUIS MOTOR

PENTAIR FAIRBANKS NIJHUIS™	
DWG NO 543WA009	REV NO 1

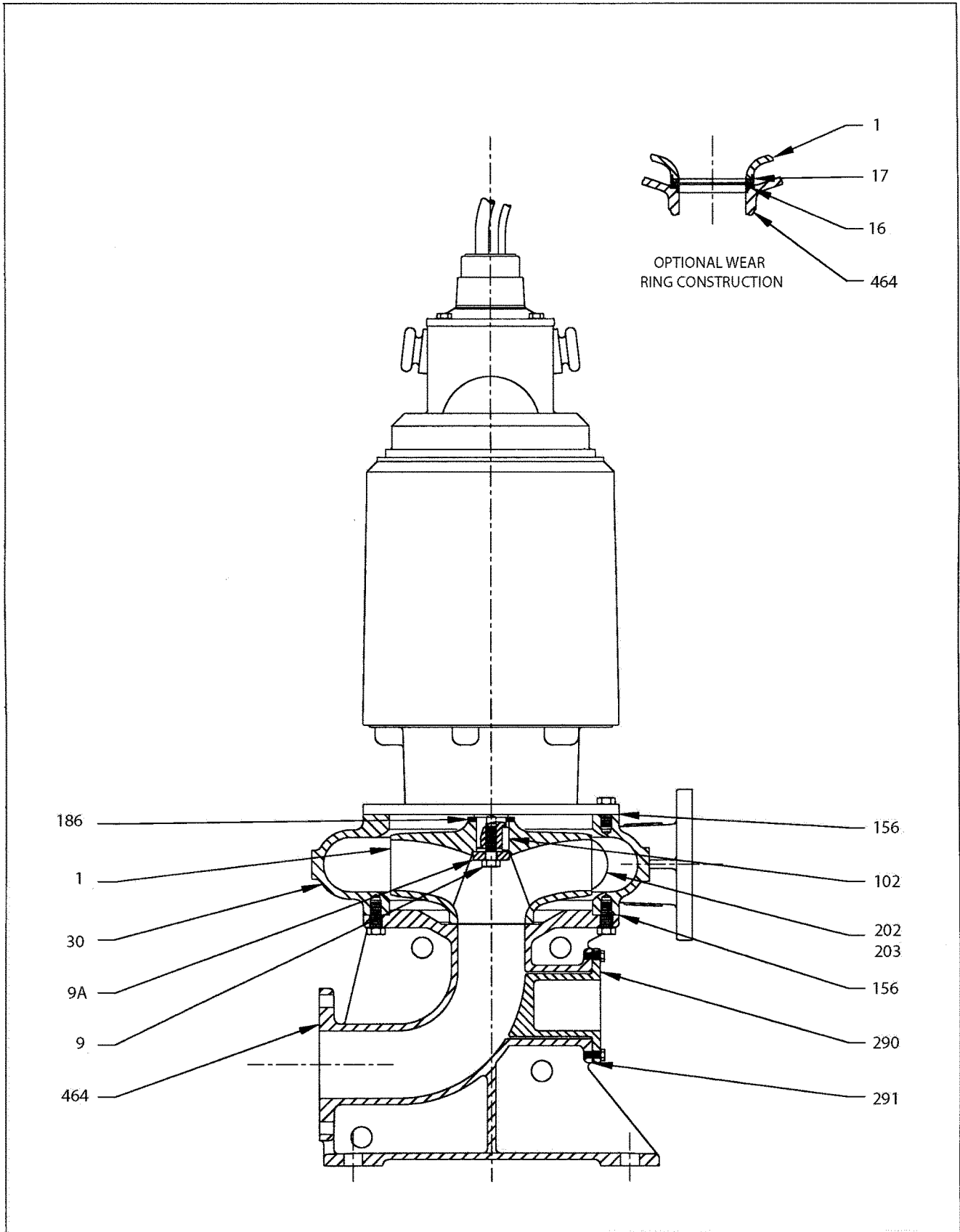

ASSEMBLY, D5430CWD, SUBMERSIBLE
COMBINATION BASE ELBOW AND F.N. MOTOR

 PENTAIR		FAIRBANKS NIJHUIS™
DWG NO	543WA017	REV NO 0

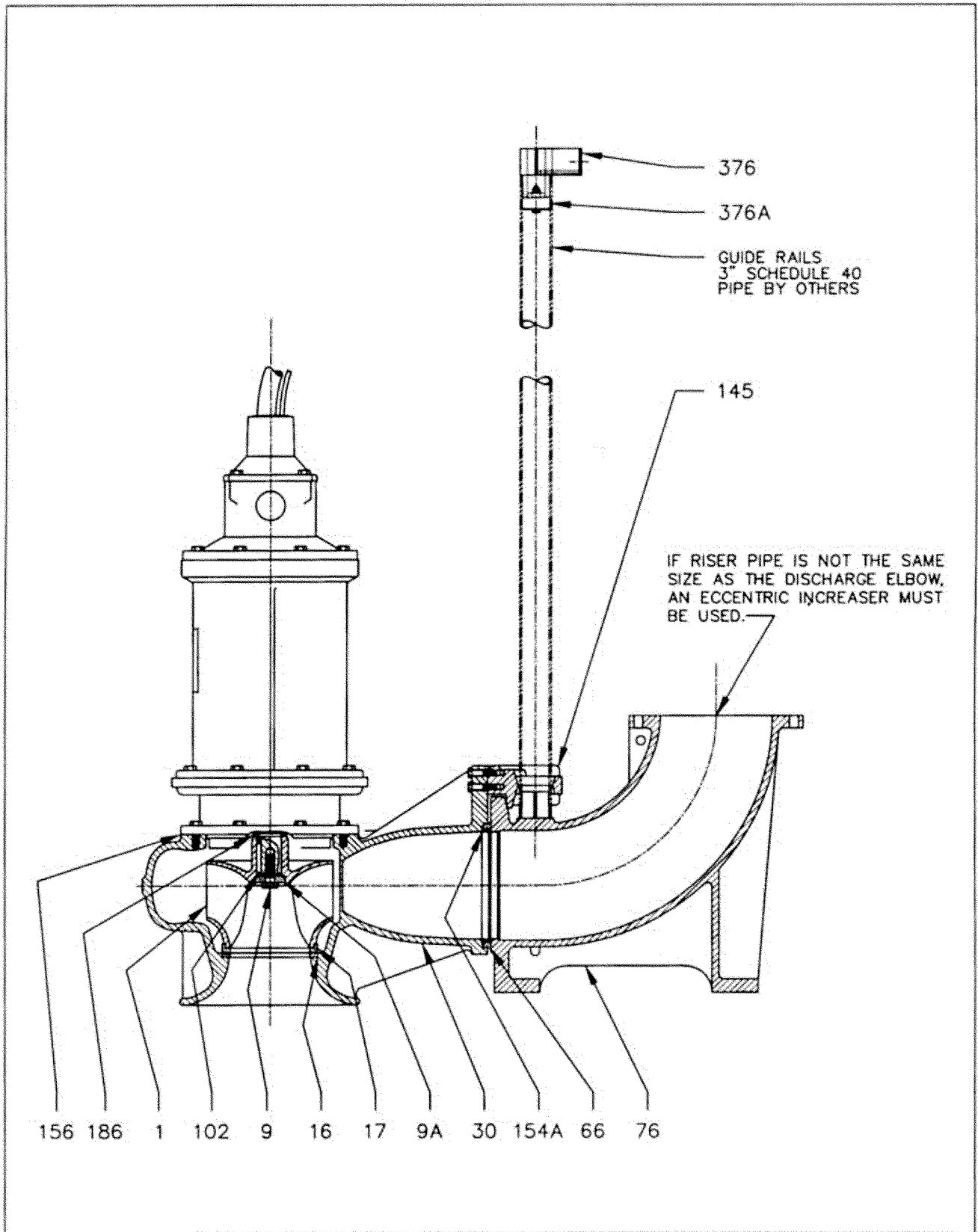

156 186 1 102 9 16 17 9A 30 154A 66 76

ASSEMBLY, 12" D5731MV, SUBMERSIBLE CENTERLINE
 PULL-UP, FAIRBANKS NIJHUIS MOTOR

PENTAIR FAIRBANKS NIJHUIS	
DWG NO 573MA031	REV NO 1

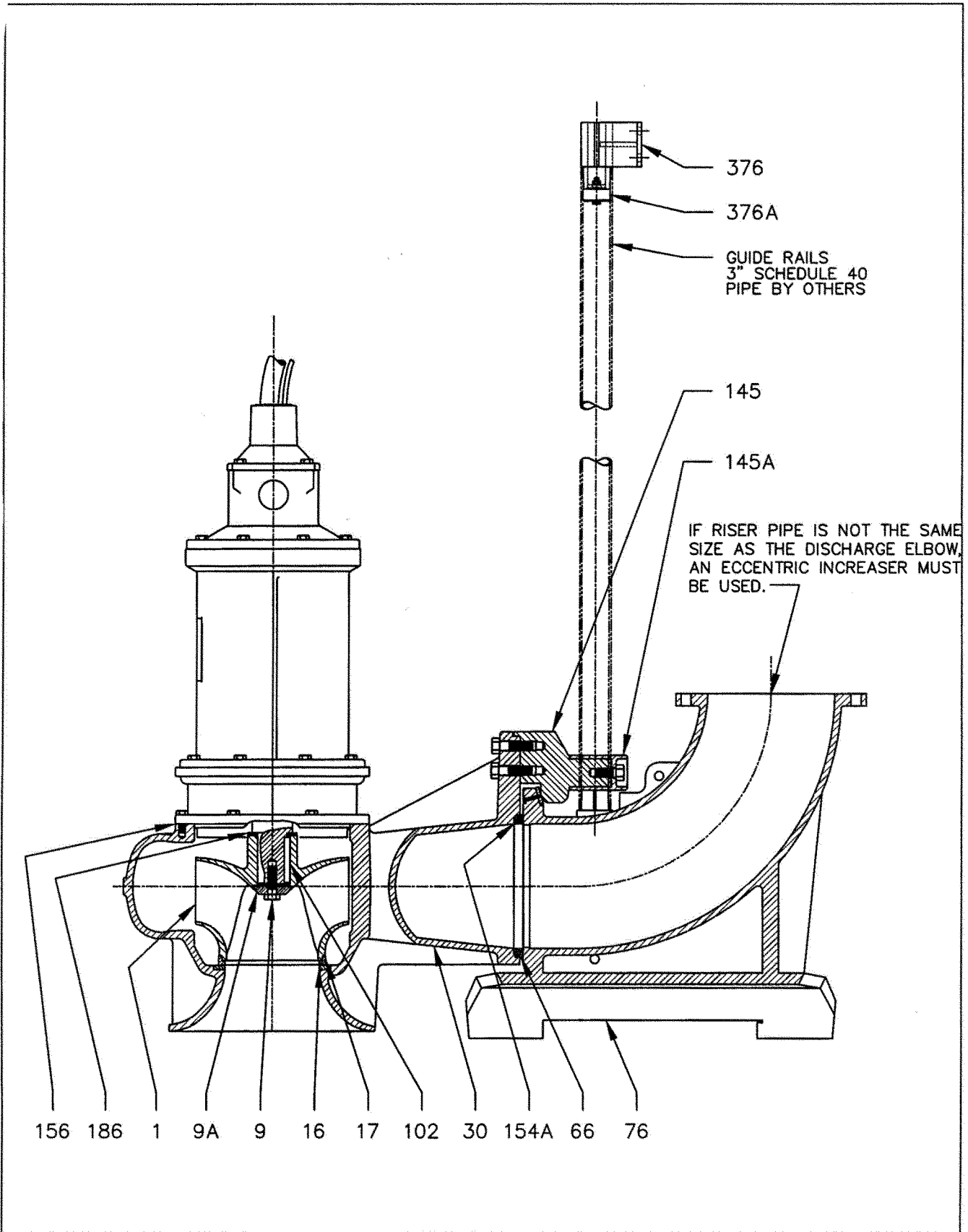

ASSEMBLY, 14" & 16" D5731MV, SUBMERSIBLE
 CENTERLINE PULL-UP, FAIRBANKS NIJHUIS MOTOR

PENTAIR FAIRBANKS NIJHUIS	
DWG NO 573MA033	REV NO 1

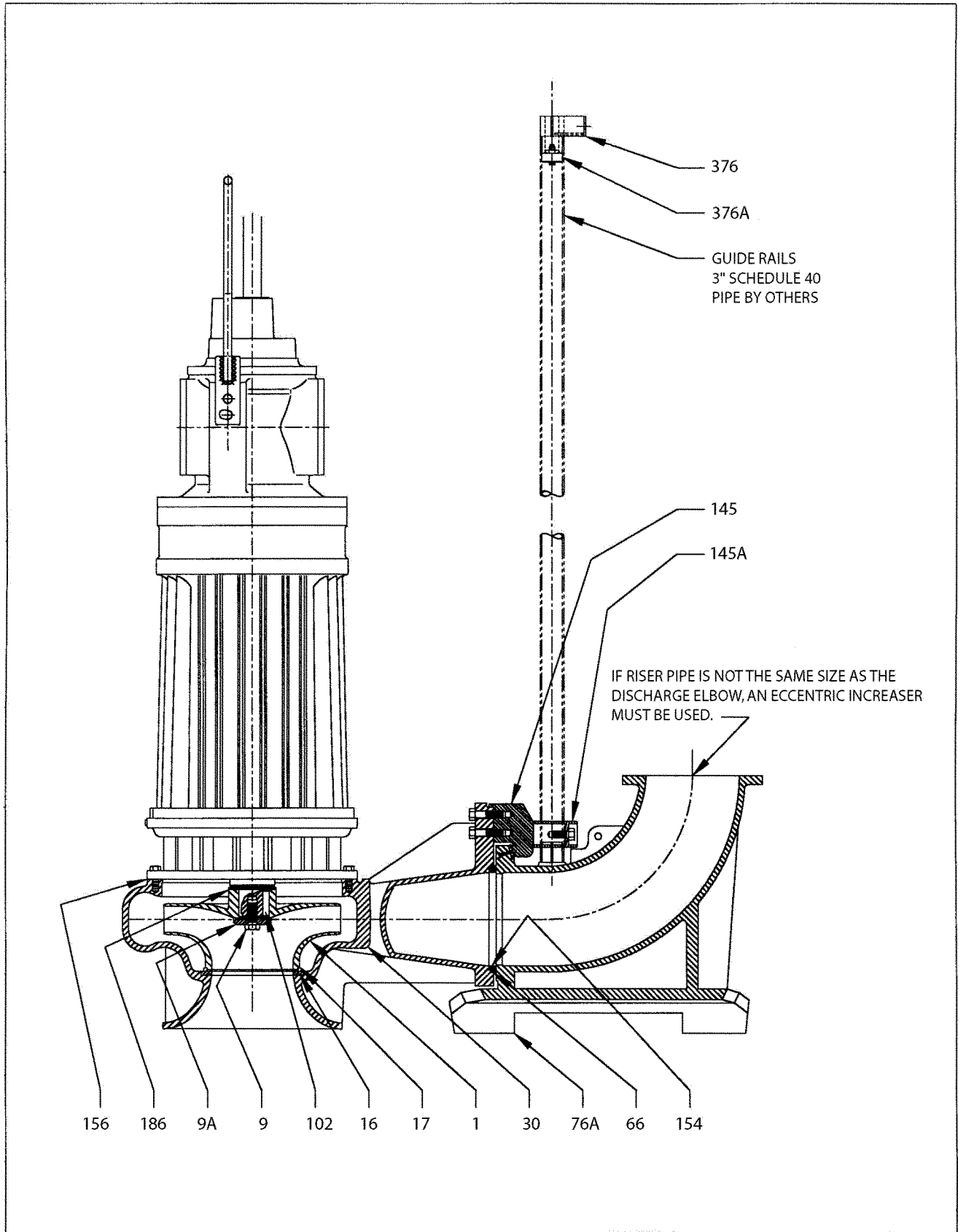

ASSEMBLY, 14" D5733MV, SUBMERSIBLE CENTERLINE
 PULL-UP, FAIRBANKS NIJHUIS MOTOR

PENTAIR FAIRBANKS NIJHUIS	
DWG NO 573MA013	REV NO 0

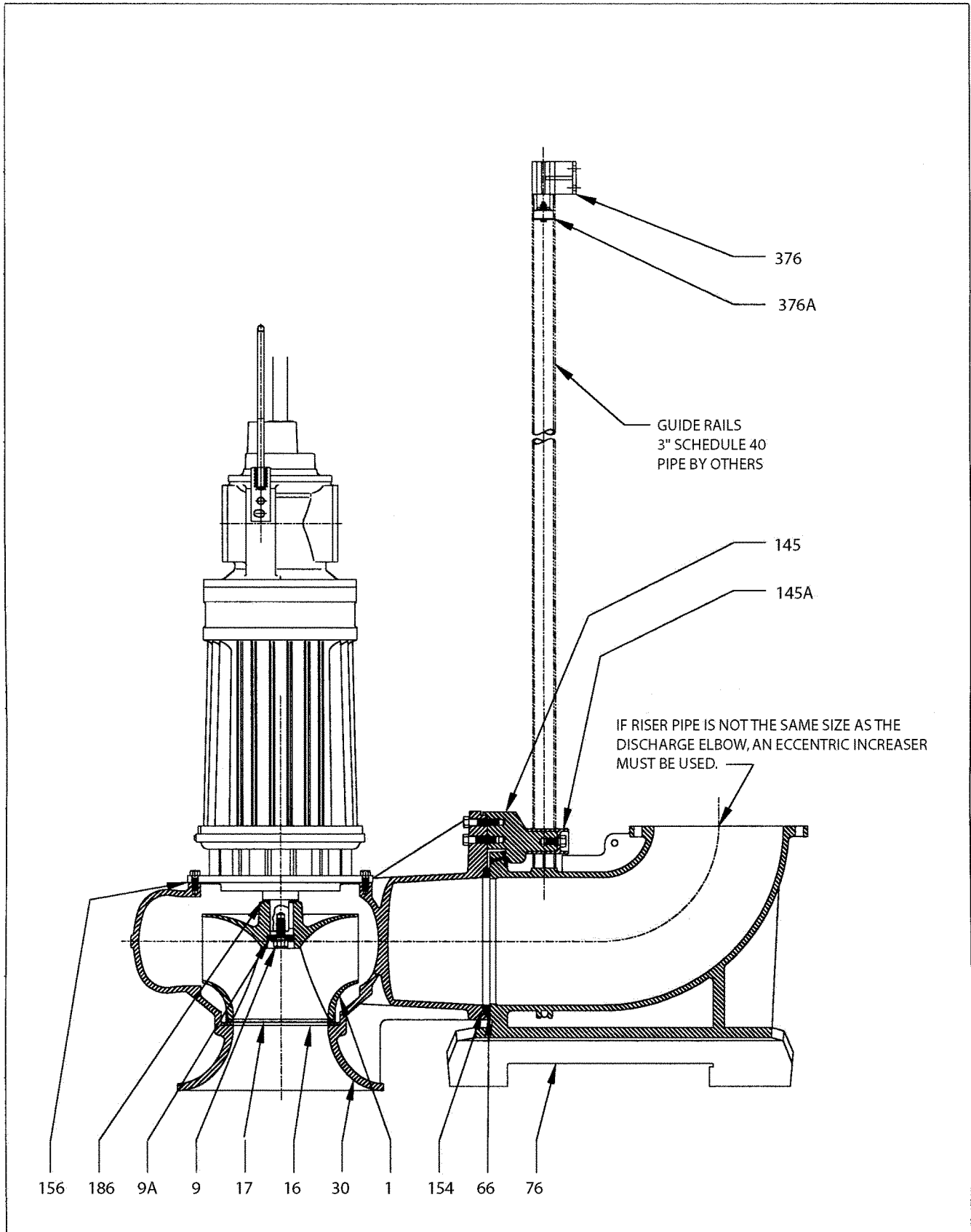

ASSEMBLY, 18" & 20" D5831MV, CENTERLINE
SUBMERSIBLE PULL-UP, FAIRBANKS NIJHUIS MOTOR

PENTAIR FAIRBANKS NIJHUIS

DWG NO 573MA035 REV NO 0

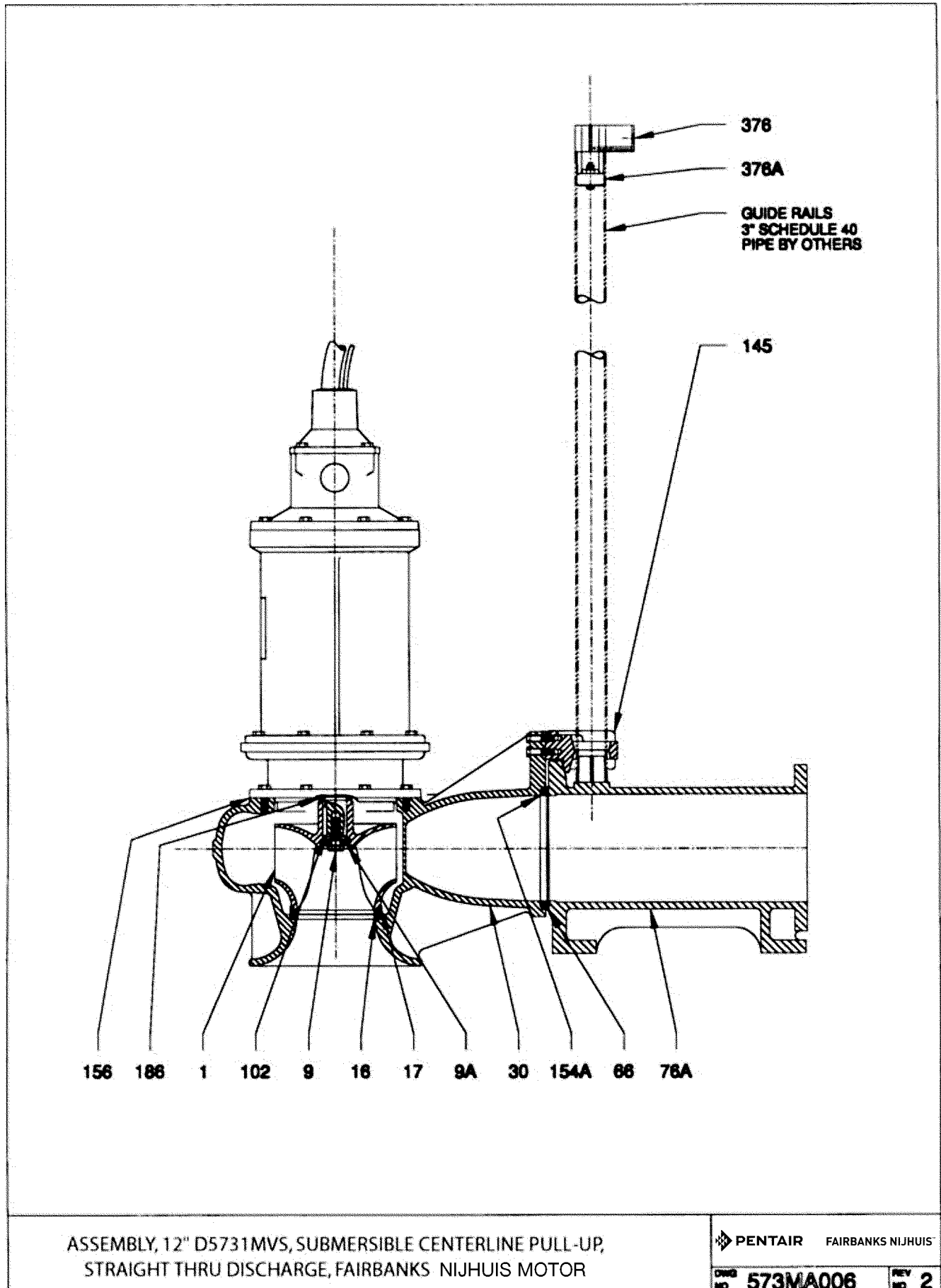

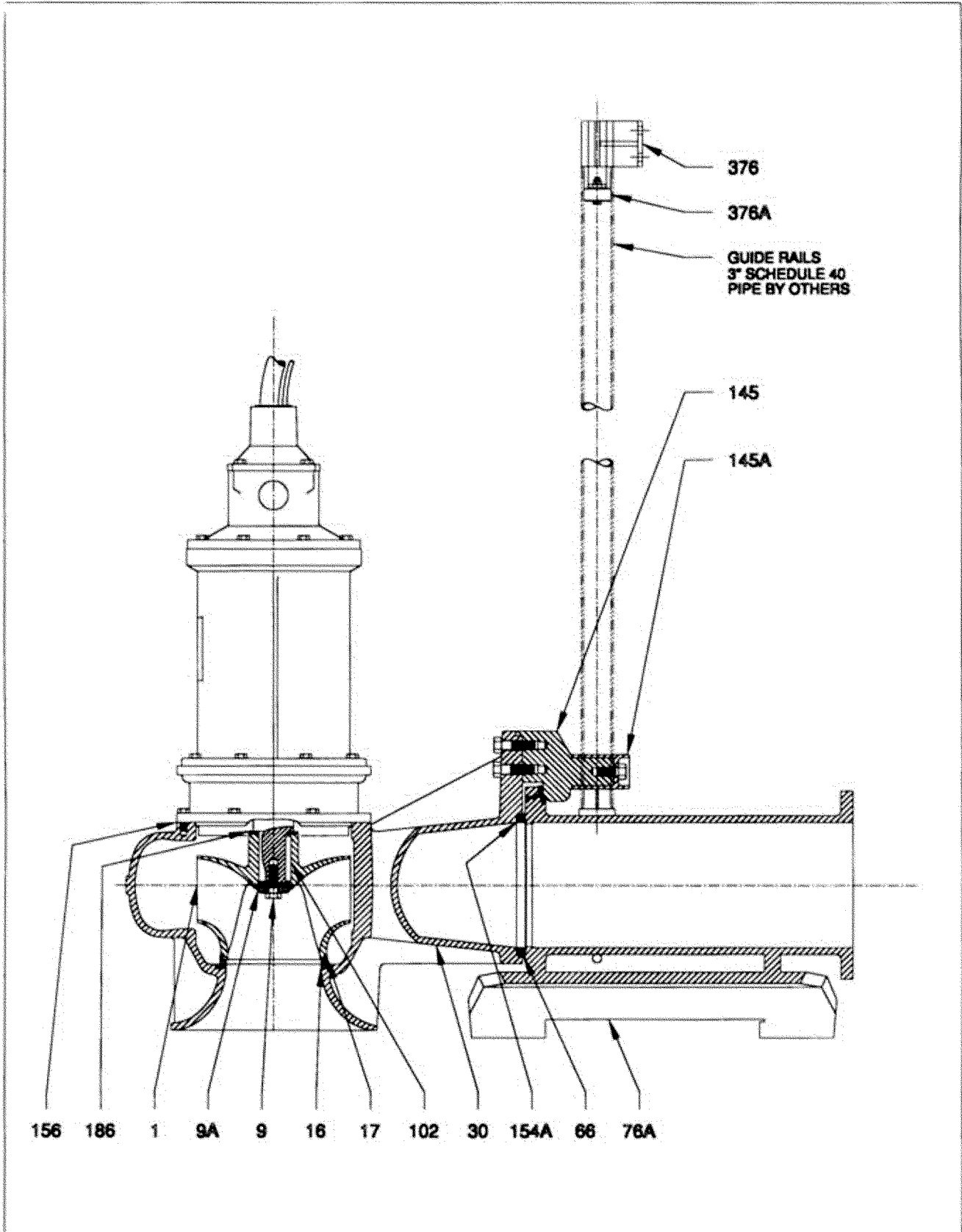

ASSEMBLY, 14" D5731MVS, SUBMERSIBLE CENTERLINE PULL-UP,
STRAIGHT THRU DISCHARGE, FAIRBANKS NIJHUIS MOTOR

 PENTAIR	FAIRBANKS NIJHUIS
DRWG NO 573MA007	REV NO 0

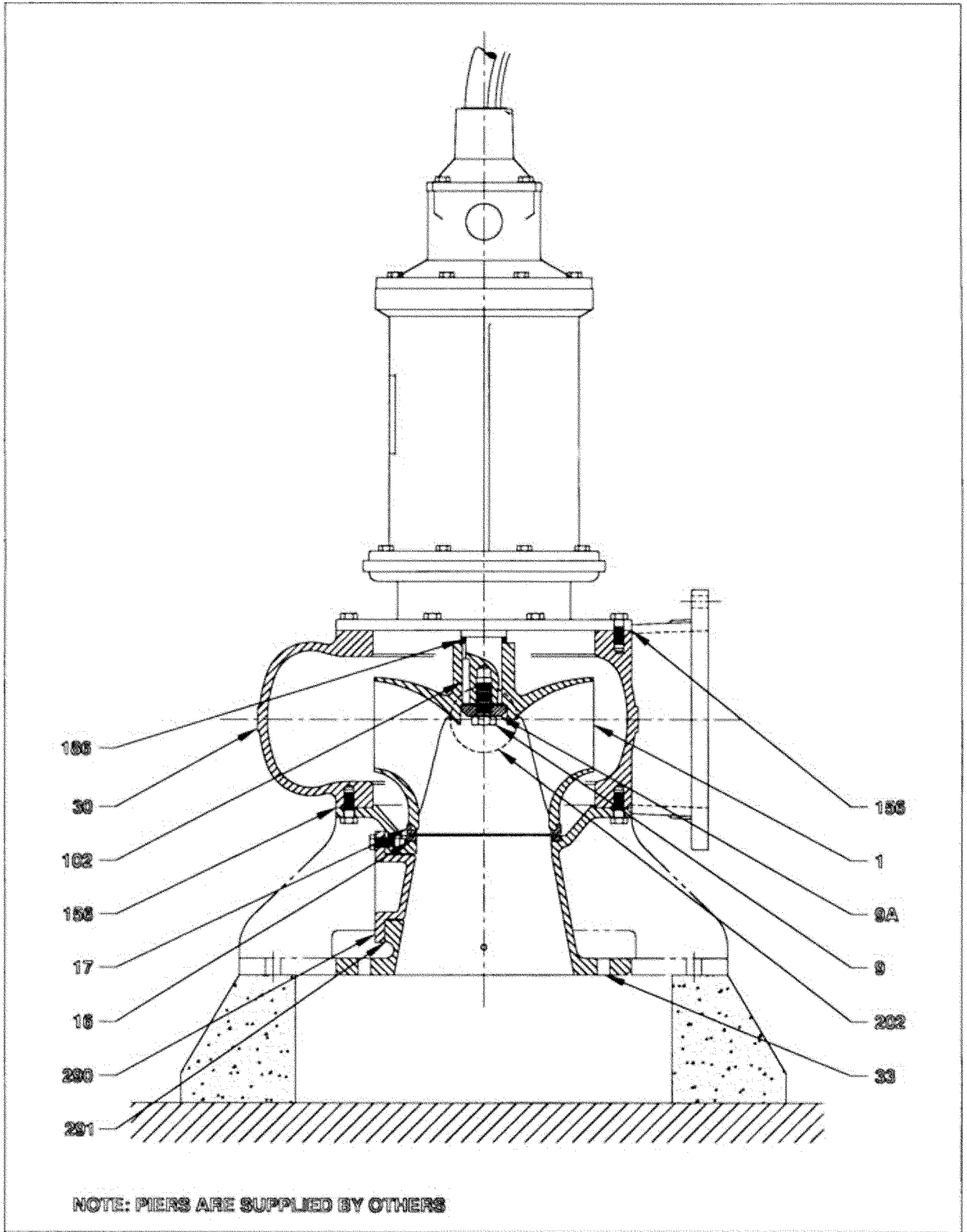

NOTE: PIERS ARE SUPPLIED BY OTHERS

**ASSEMBLY, 12" THRU 24" D5731W, SUBMERSIBLE
 FAIRBANKS NIJHUIS MOTOR**

PENTAIR FAIRBANKS NIJHUIS	
DWG NO 573WA003	REV NO 2

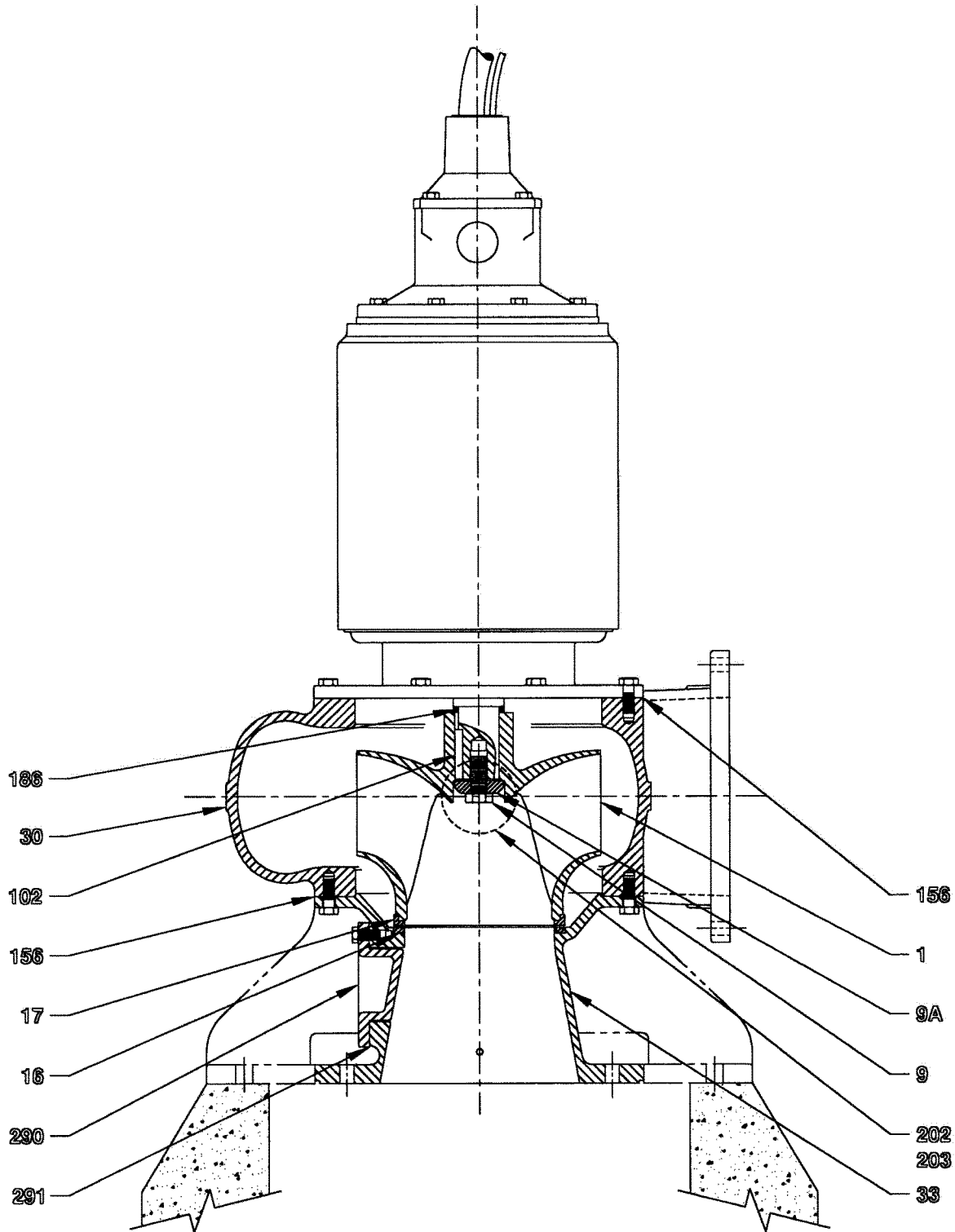

NOTE: PIERS ARE SUPPLIED BY OTHERS

ASSEMBLY, 12" THRU 24" D5731WD, DRY-PIT SUBMERSIBLE
FAIRBANKS NIJHUIS MOTOR

PENTAIR FAIRBANKS NIJHUIS™

DWG NO 573WA023 REV NO 1

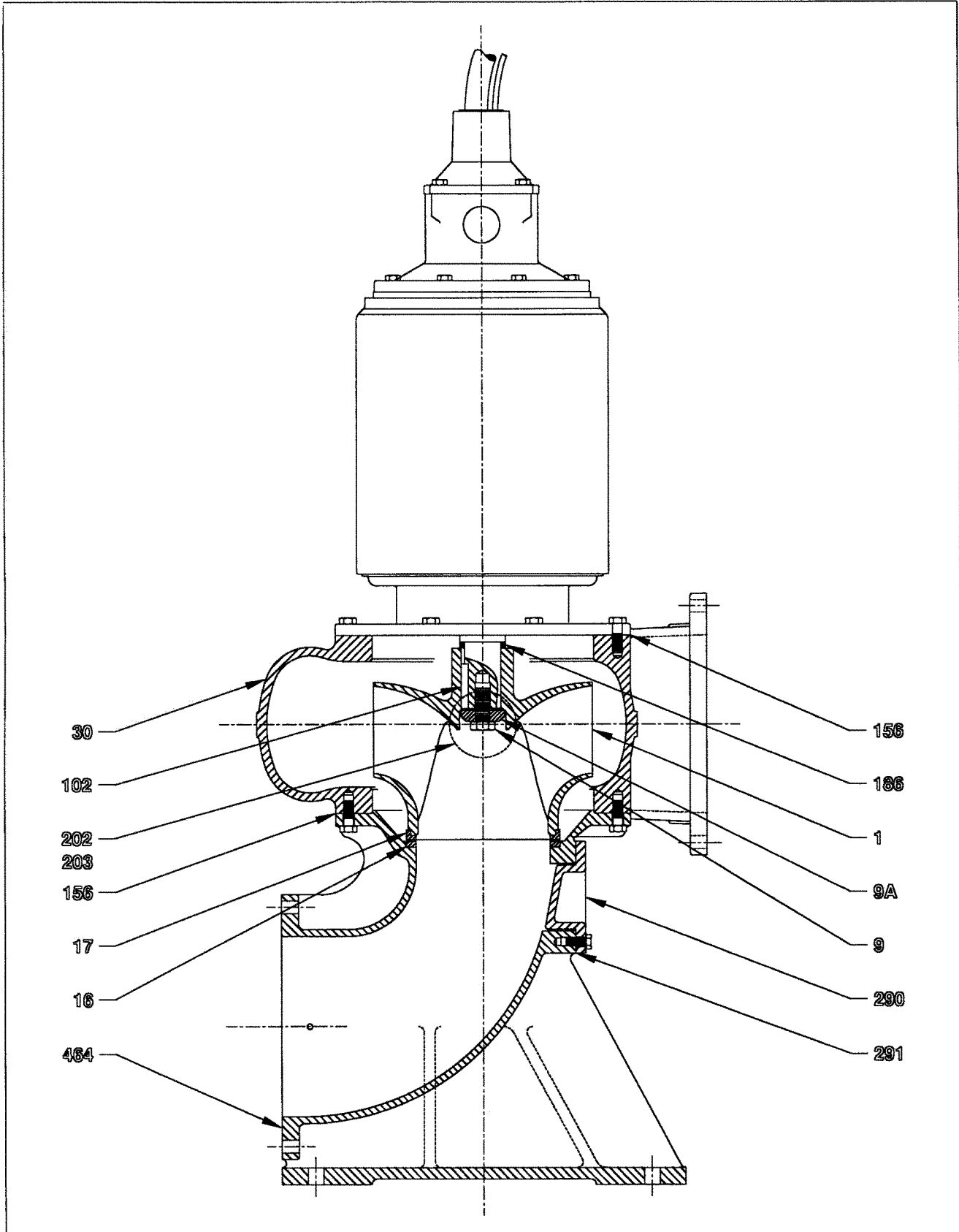

ASSEMBLY, 12", 14", & 16" D5731CWD, DRY-PIT SUBMERSIBLE COMBINATION BASE ELBOW AND FAIRBANKS NIJHUIS MOTOR

PENTAIR FAIRBANKS NIJHUIS

DWG NO	573WA033	REV NO	1
--------	----------	--------	---

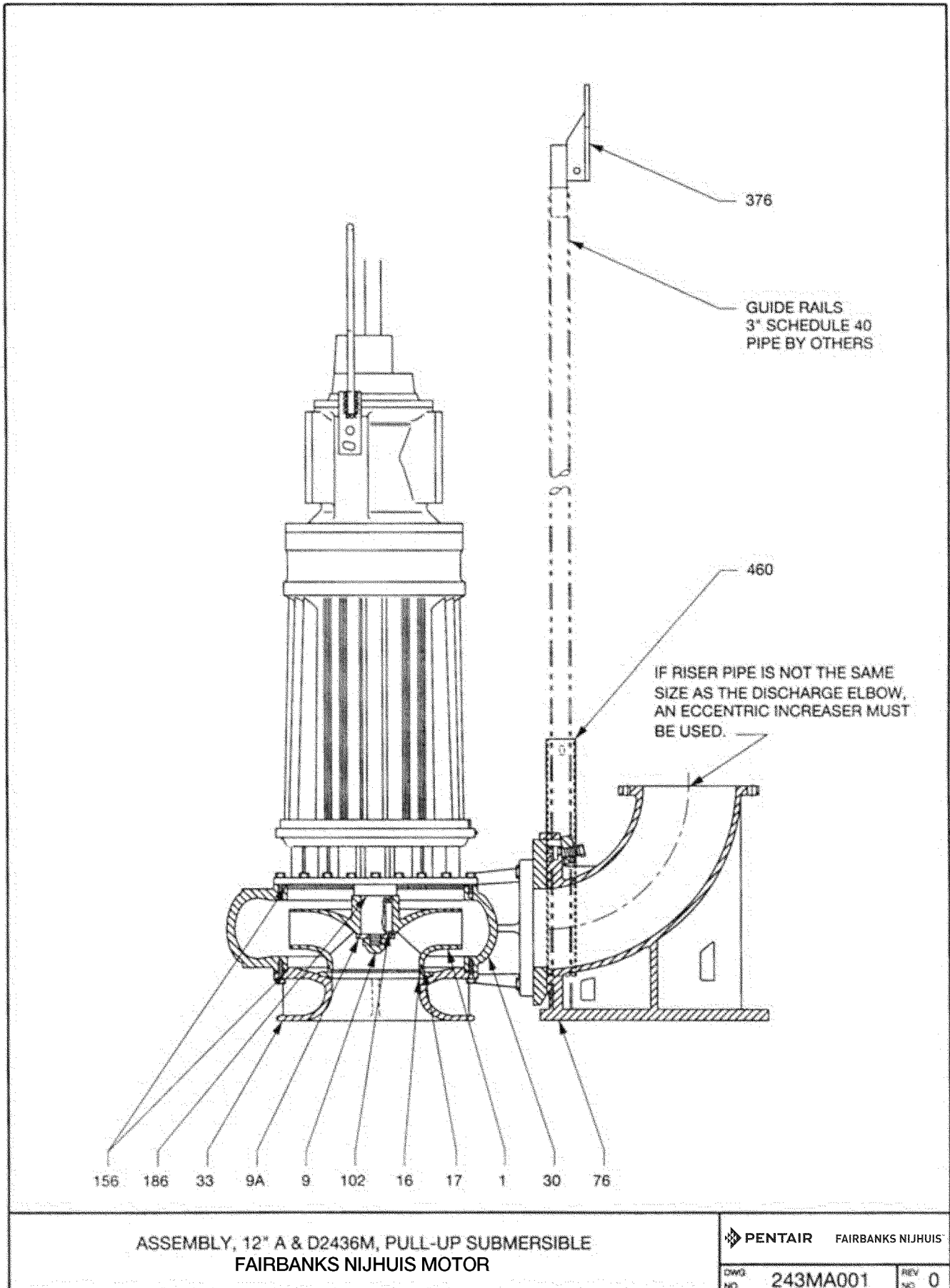

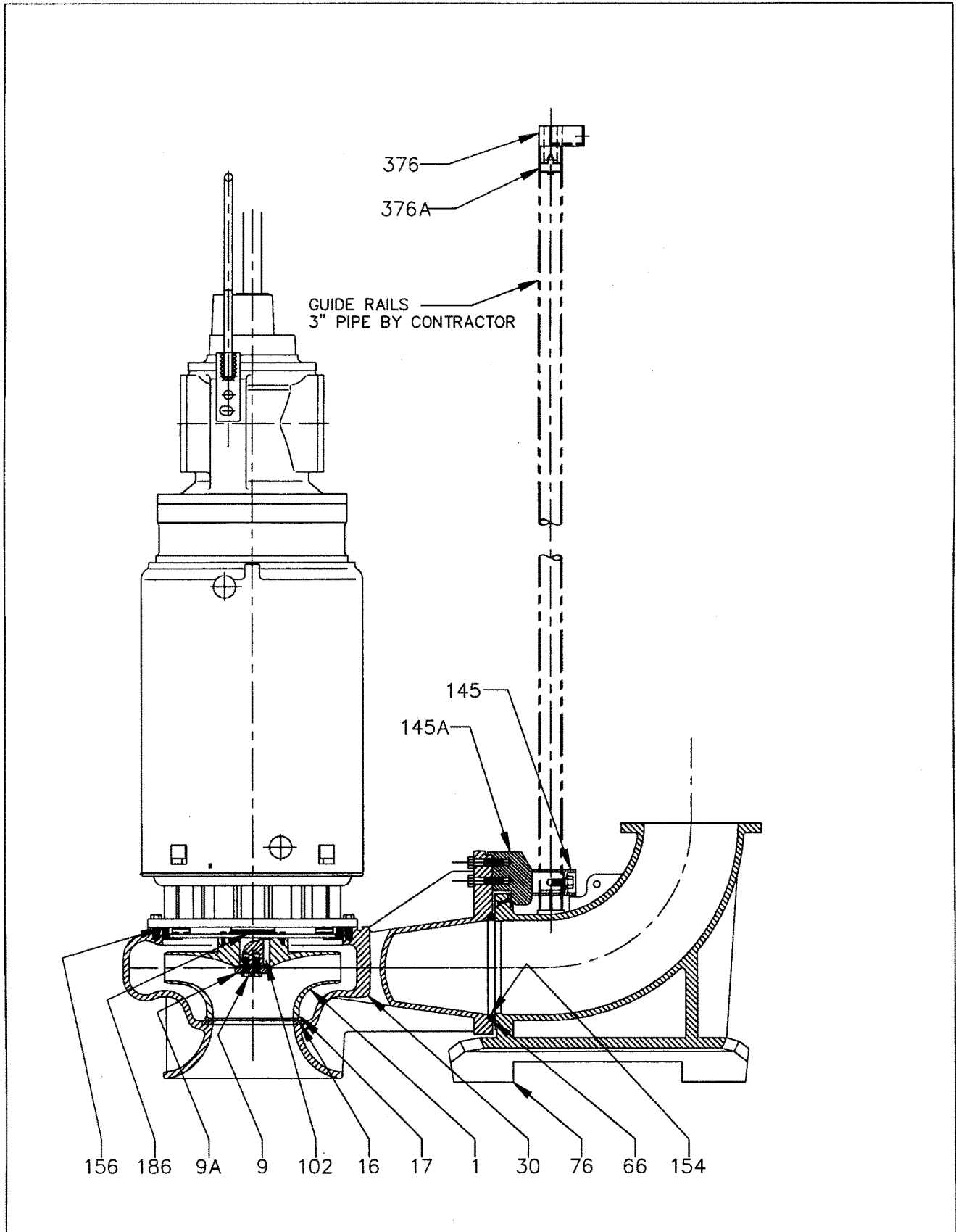

ASSEMBLY, D2430MV, SUBMERSIBLE
 CENTERLINE PULL-UP, FAIRBANKS NIJHUIS MOTOR

PENTAIR FAIRBANKS NIJHUIS	
DWG NO	2430M005 REV NO 0

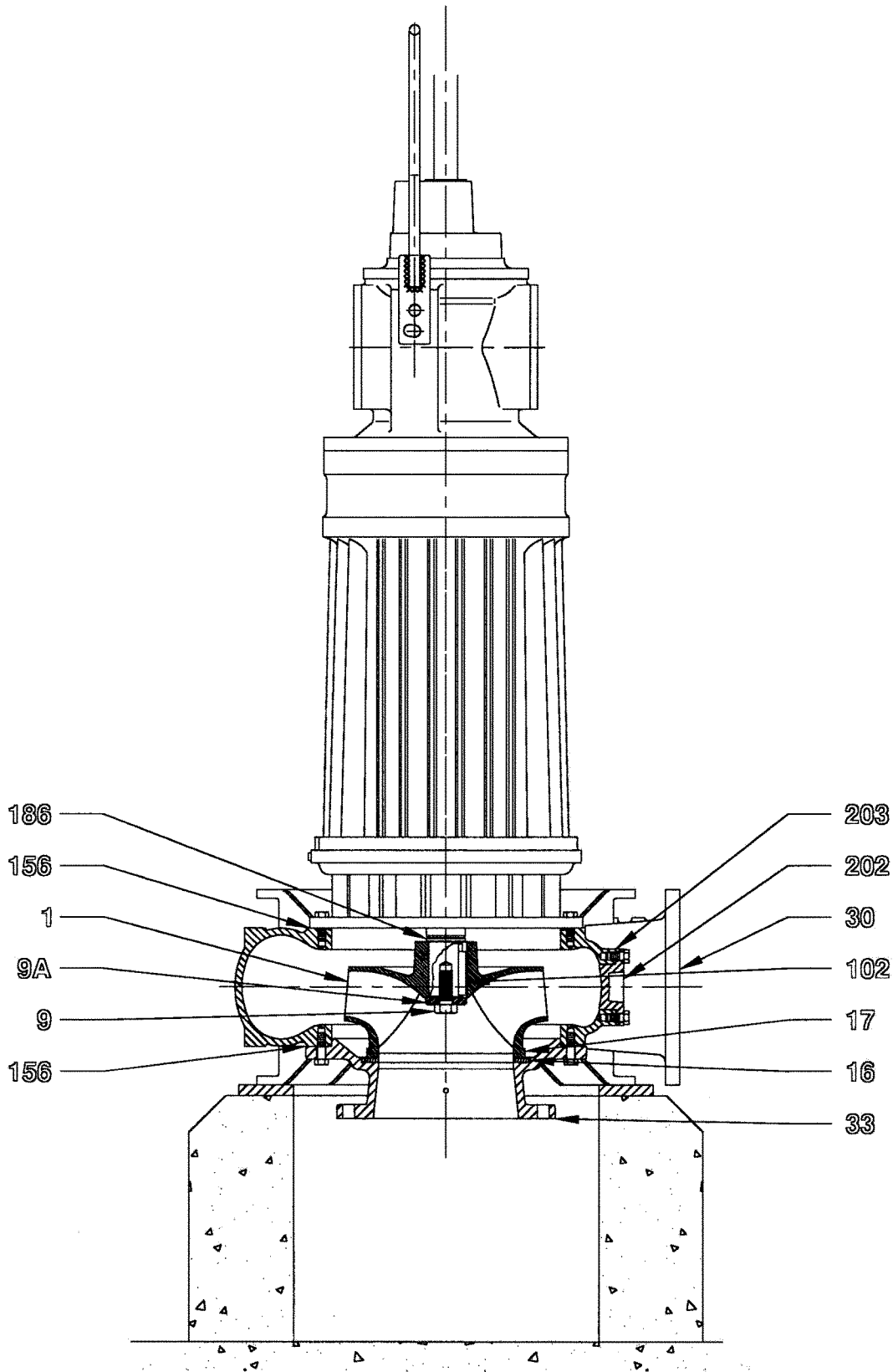

NOTE: PIERS ARE SUPPLIED BY OTHERS.

ASSEMBLY, 12" AND 16"D2430W, SUBMERSIBLE
FAIRBANKS NIJHUIS MOTOR

PENTAIR FAIRBANKS NIJHUIS

DWG NO 243WA001 REV NO 0

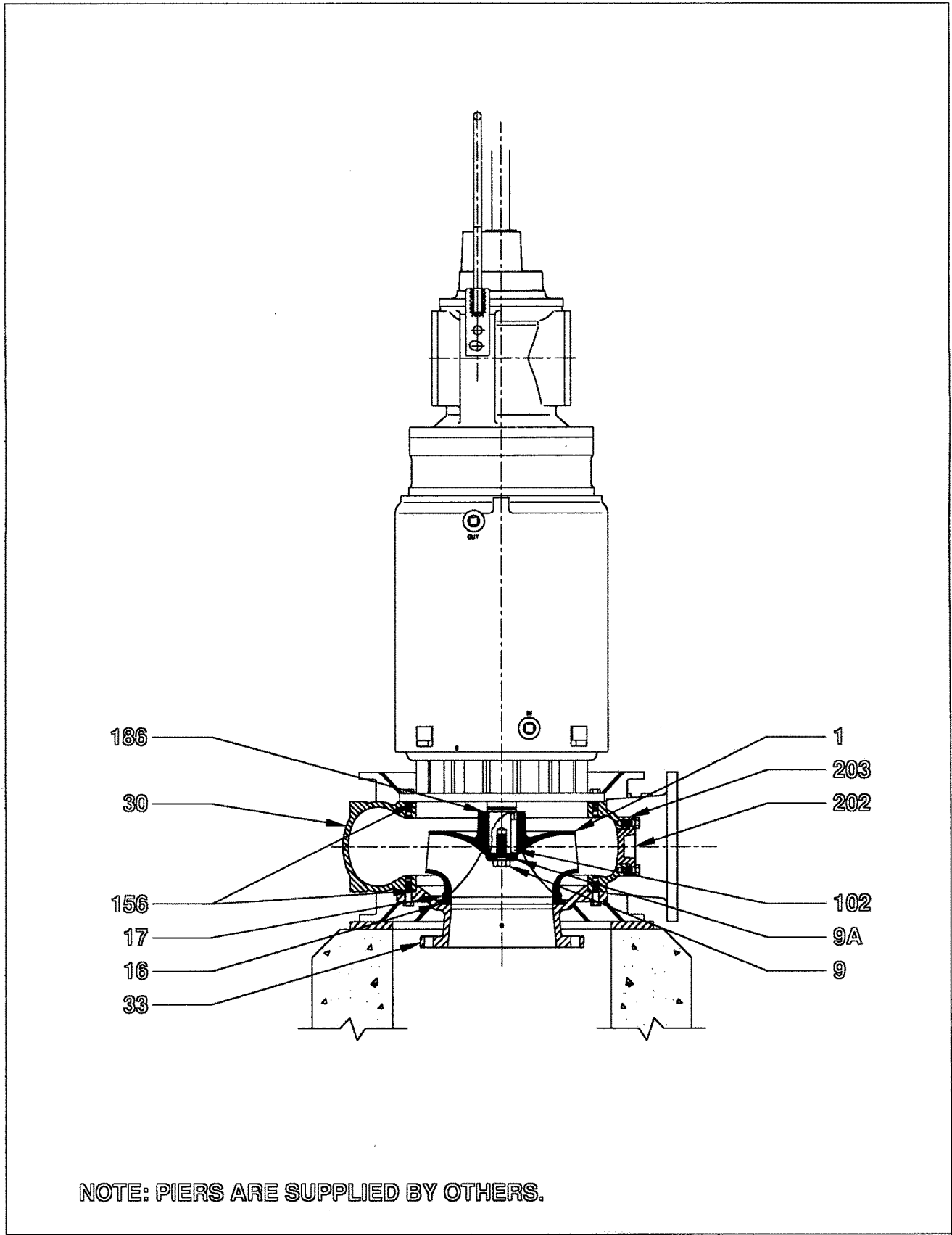

NOTE: PIERS ARE SUPPLIED BY OTHERS.

ASSEMBLY, 12" AND 16" D2430WD, SUBMERSIBLE FAIRBANKS NIJHUIS MOTOR		PENTAIR FAIRBANKS NIJHUIS
DWG NO 243WA009	REV NO 0	

D5430, 5730 and 2430 M&W Parts Identification List

REFERENCE NUMBER	DESCRIPTION
1	Impeller
9	Capscrew, Impeller
9A	Washer, Impeller
15	Base
16	Wear Ring, Fronthead
17	Wear Ring, Impeller
30	Volute
33	Fronthead
44	Elbow, Suction
66	Ring, Flange
76	Base Elbow, Discharge
102	Key, Impeller
145	Bracket, Guide
154	Gasket, Elbow
154A	Seal, Flange
156	Gasket, Volute
186	Shim, Impeller
202	Cover, Volute Handhole
203	Gasket, Volute Handhole Cover
290	Cover, Suction Elbow Handhole
291	Gasket, Suction Elbow Handhole Cover
376	Bracket, Upper Guide
376A	Bushing, Upper Guide Bracket
460	Coupling, Discharge

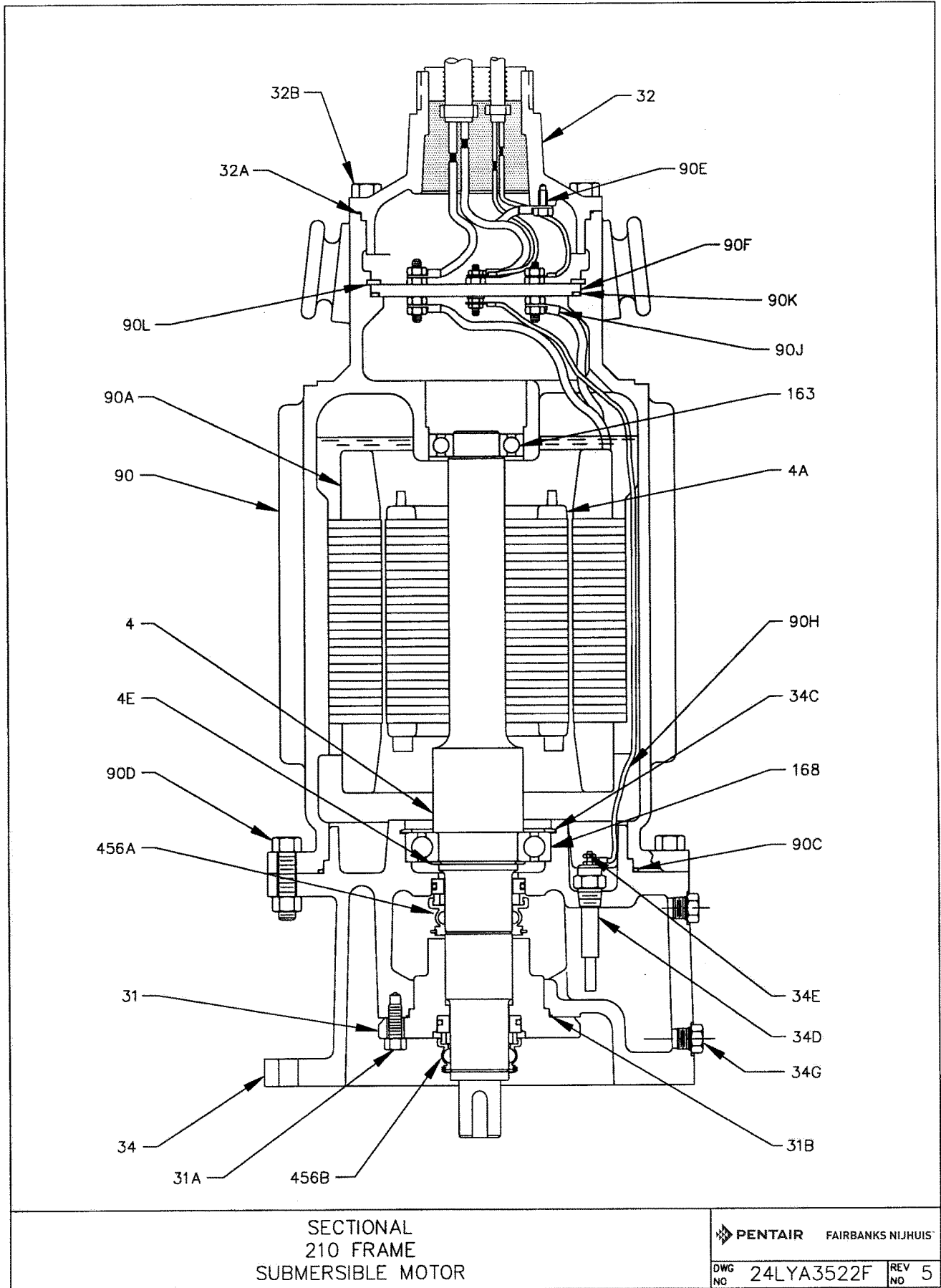

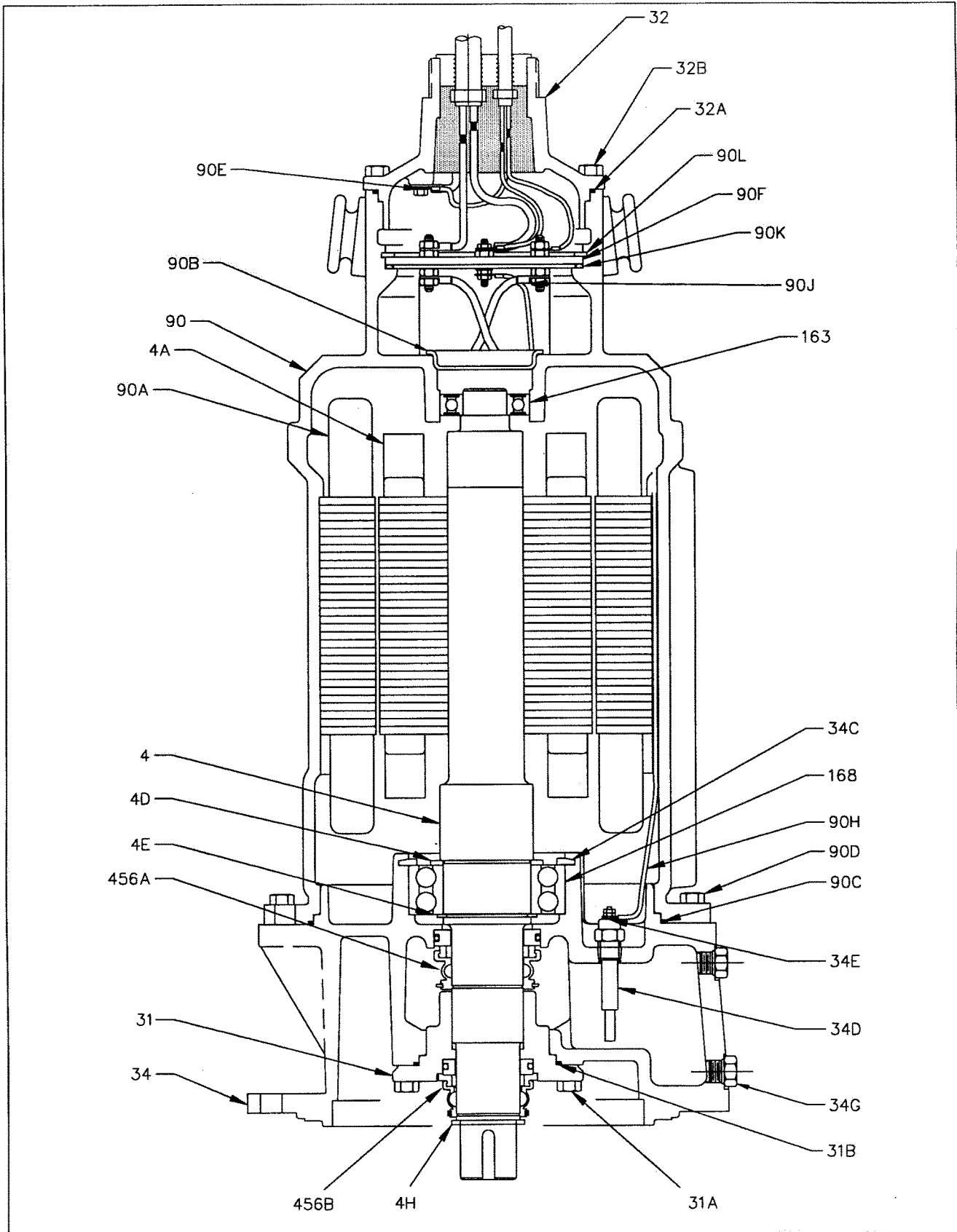

SECTIONAL
250 FRAME
SUBMERSIBLE MOTOR

 PENTAIR FAIRBANKS NIJHUIS	
DWG NO	24LYA3522D
REV NO	6

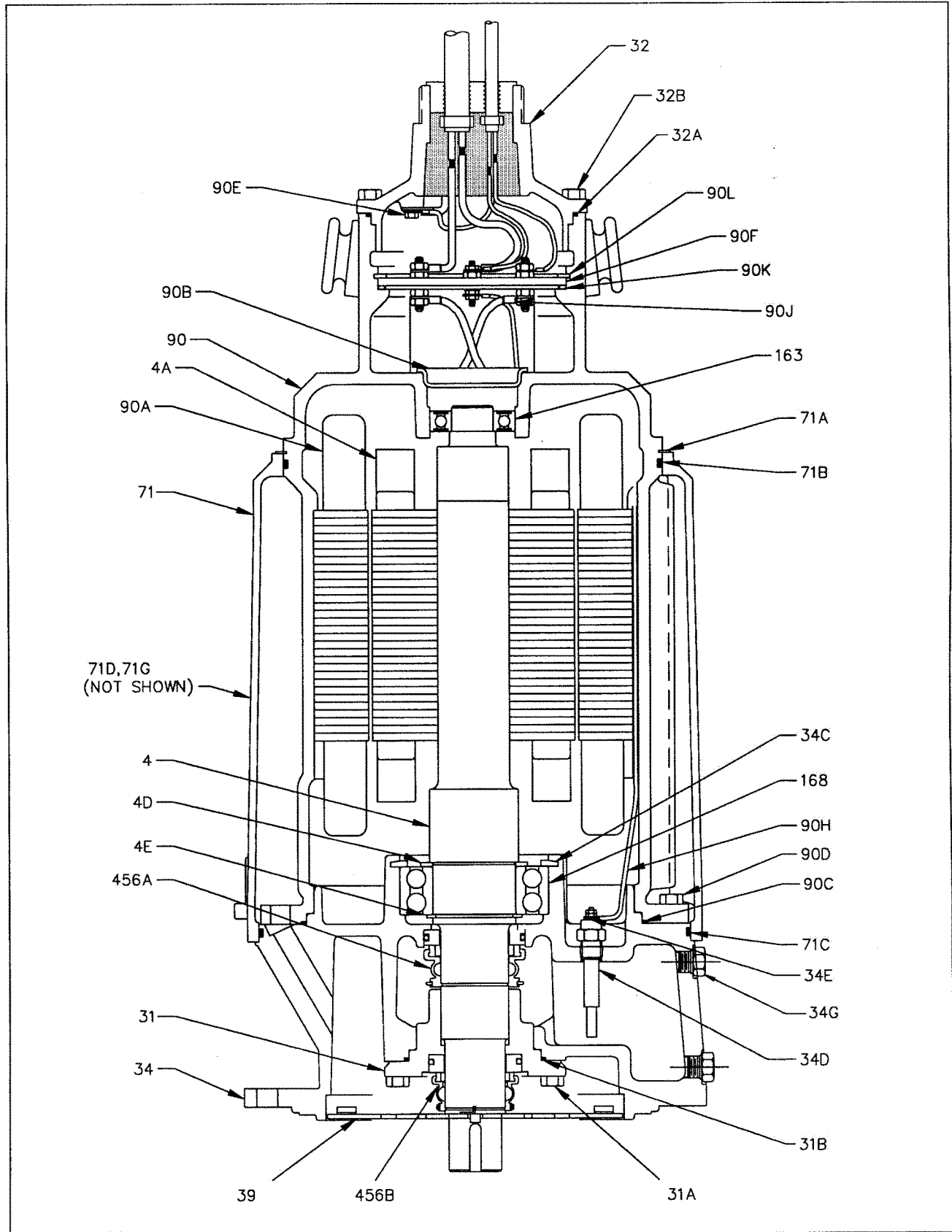

SECTIONAL
 250 FRAME
 SUBMERSIBLE MOTOR WITH JACKET

PENTAIR FAIRBANKS NIJHUIS™

DWG NO	24LYA3522C	REV NO	8
--------	------------	--------	---

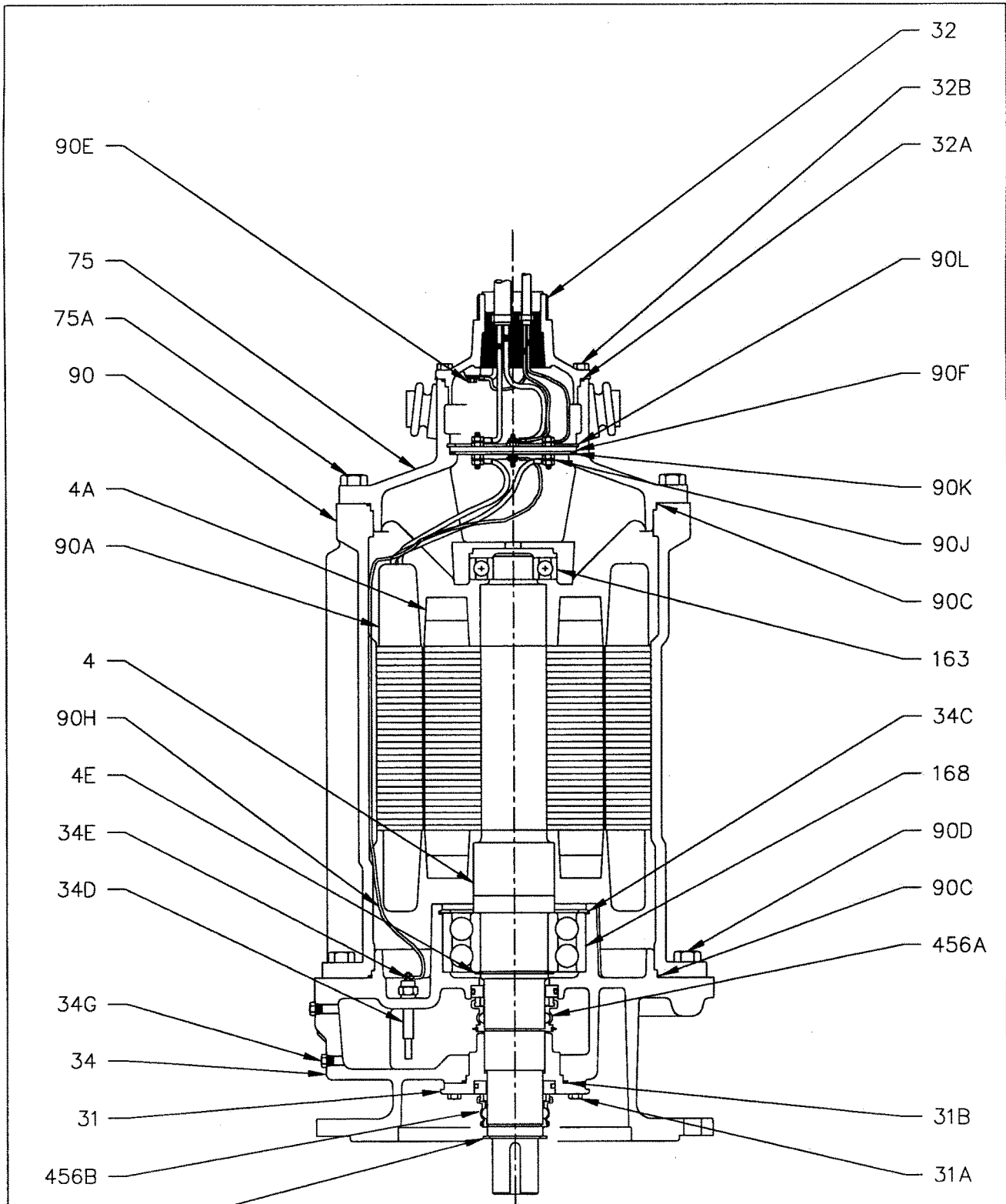

STANDARD DESIGN 320 FRAME MOTOR
OPTIONAL DESIGN 360 & 365 FRAME MOTOR

SECTIONAL
320, 360 & 365 FRAME
SUBMERSIBLE MOTOR

 PENTAIR FAIRBANKS NIJHUIS™	
DWG NO	24LYA3522J
REV NO	7

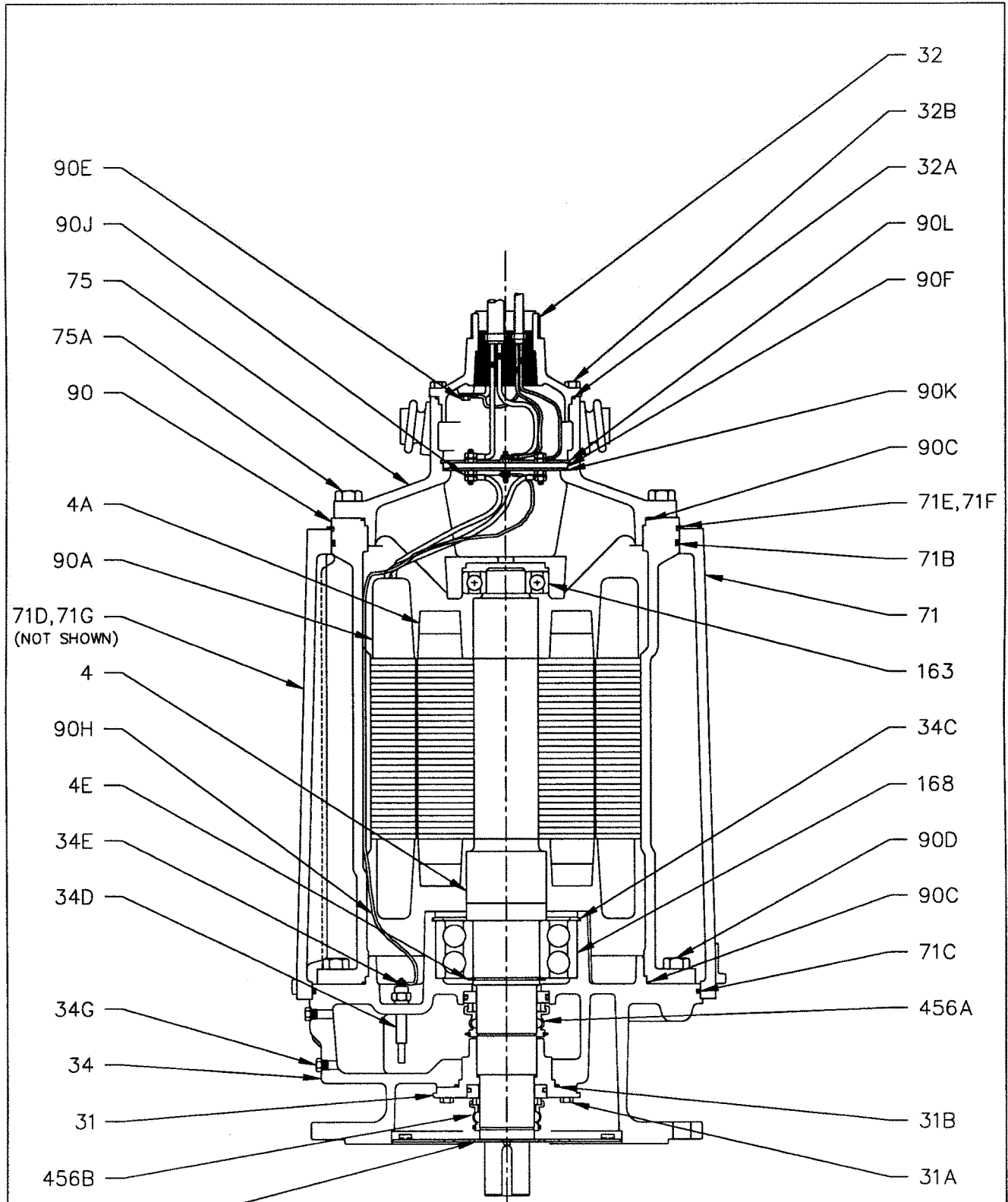

STANDARD DESIGN 320 FRAME MOTOR
 OPTIONAL DESIGN 360 & 365 FRAME MOTOR

SECTIONAL
 320, 360 & 365 FRAME
 SUBMERSIBLE MOTOR WITH WATER JACKET

PENTAIR FAIRBANKS NIJHUIS™	
DWG NO 24LYA3522H	REV NO 7

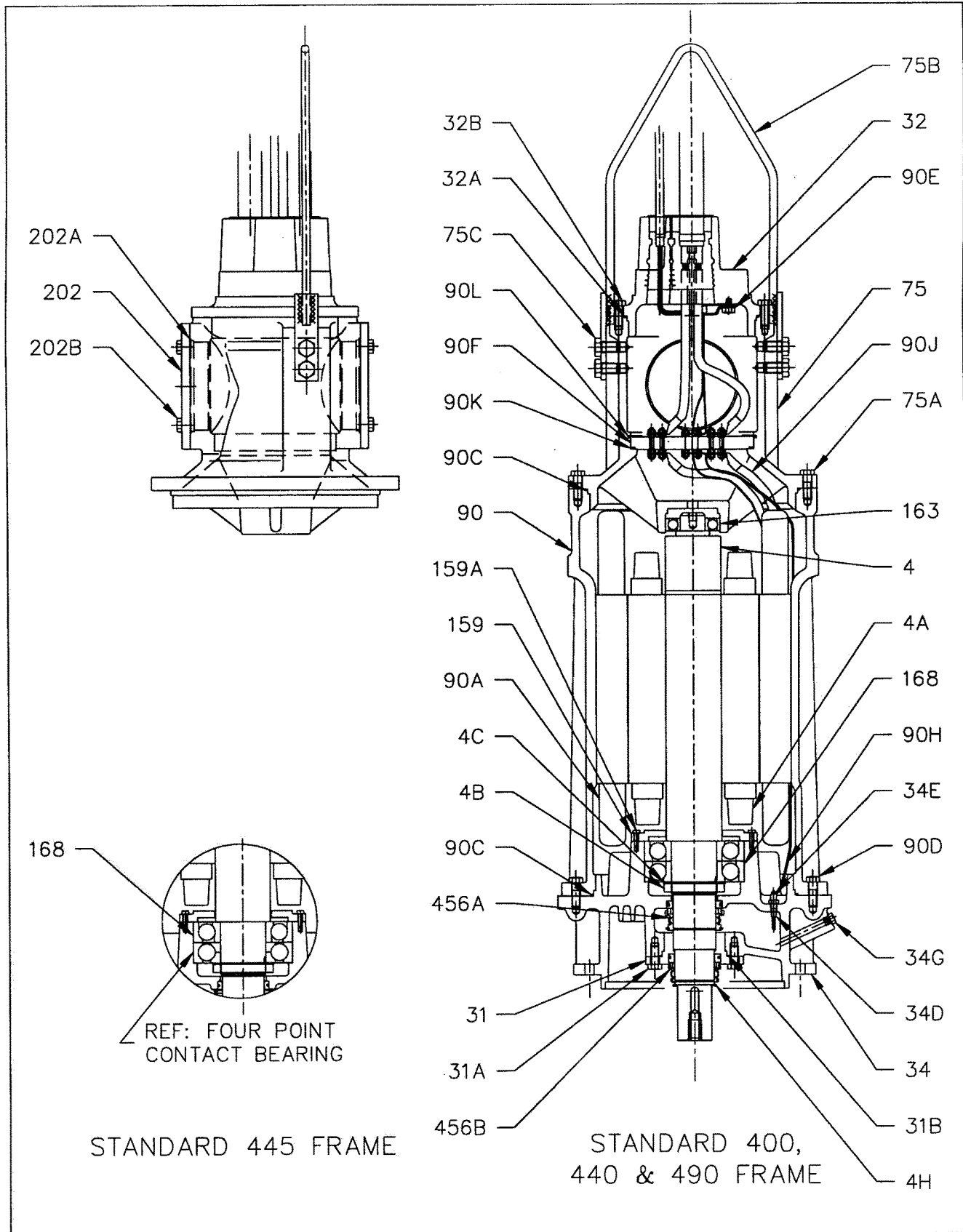

SECTIONAL
400, 440, 445 & 490 FRAME
SUBMERSIBLE MOTOR

PENTAIR FAIRBANKS NIJHUIS

DWG NO 24LYA3522L REV NO 3

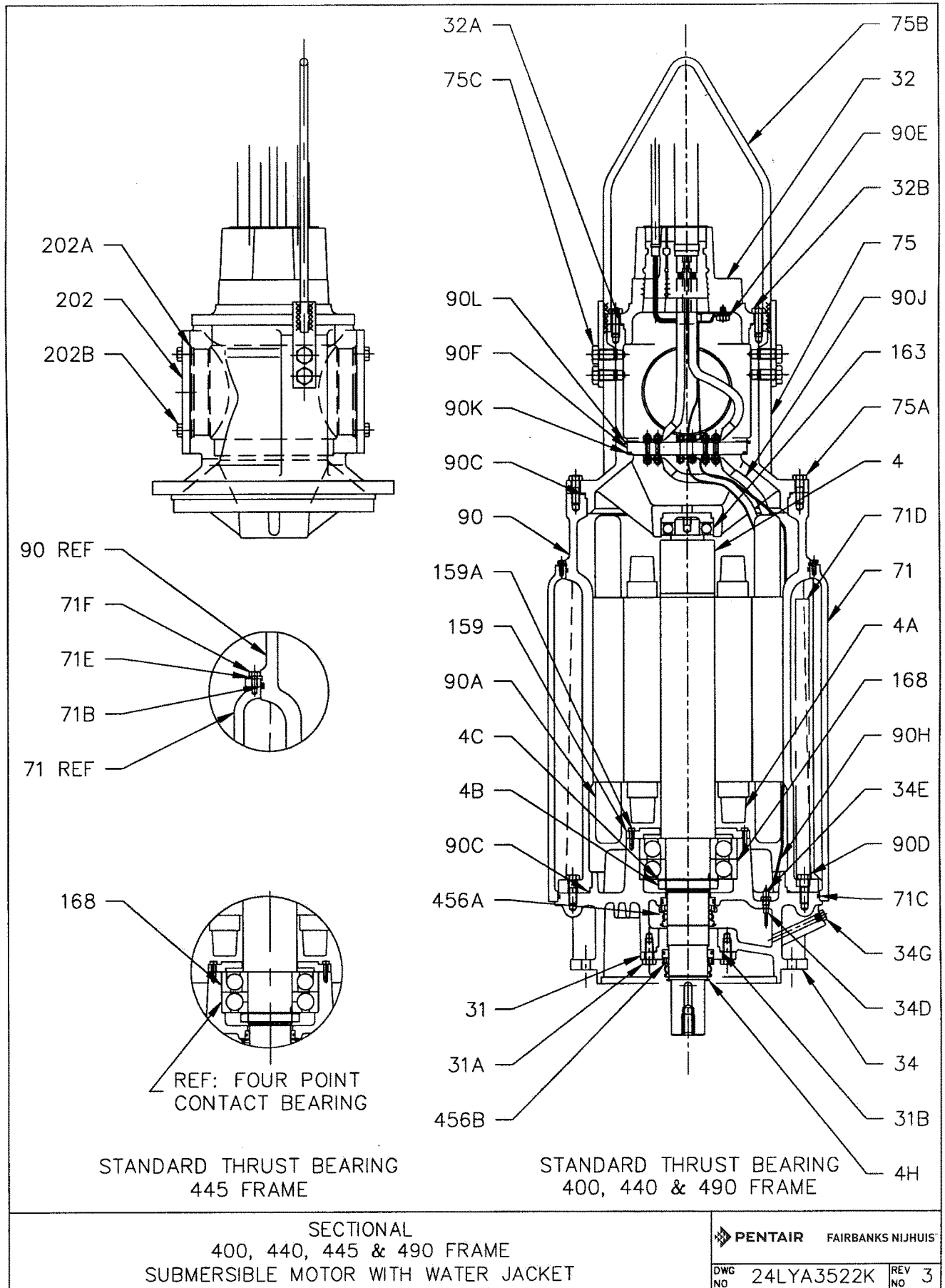

REF. NO.	DESCRIPTION	MATERIAL	SPECIFICATION (1)
4	SHAFT, MOTOR	STAINLESS STEEL	A582 TYPE 416
4A	ROTOR	_____	_____
4B	LOCKNUT	STEEL	COMMERCIAL
4C	LOCKWASHER	STEEL	COMMERCIAL
4D	WASHER, PRECISION	STEEL	COMMERCIAL
4E	RETAINING RING, BEARING	STEEL	COMMERCIAL
4H	SPACER	STAINLESS STEEL	18-8
31	GLAND, SEAL	CAST IRON	A48 CL30
31A	CAPSCREW, GLAND SEAL	STAINLESS STEEL	AISI TYPE 316
31B	O-RING, GLAND SEAL	RUBBER	BUNA-N
32	COVER, CABLE ASSEMBLY	_____	_____
32A	O-RING, COVER	RUBBER	BUNA-N
32B	CAPSCREWS, COVER	STAINLESS STEEL	AISI TYPE 316
34	LOWER BEARING HOUSING	CAST IRON	A48 CL30
34C	RETAINING RING, BEARING	STEEL	COMMERCIAL
34D	MOISTURE DETECTORS	_____	COMMERCIAL
34E	RESISTOR	_____	_____
34F	PIPE PLUGS, WATER SEAL	CAST IRON	COMMERCIAL
34G	INSPECTION PLUG	STAINLESS STEEL	18-8
39	CIRCULATOR	STAINLESS STEEL	A167 TYPE 304
71	WATER JACKET	CAST IRON	A48 CL30
71A	RETAINING RING, WATER JACKET	STAINLESS STEEL	COMMERCIAL
71B	O-RING, UPPER JACKET	RUBBER	BUNA-N
71C	O-RING, LOWER JACKET	RUBBER	BUNA-N
71D	STAND TUBE	STAINLESS STEEL	AISI TYPE 316
71E	RETAINER, JACKET	STAINLESS STEEL	AISI TYPE 316
71F	CAPSCREW, JACKET	STAINLESS STEEL	AISI TYPE 316
71G	PIPE PLUG, NPT	CAST IRON	COMMERCIAL
75	MOTOR HOUSING, TOP	CAST IRON	A48 CL30
75A	CAPSCREWS, TOP HOUSING	STAINLESS STEEL	AISI TYPE 316
75B	BAIL, LIFTING	STAINLESS STEEL	AISI TYPE 316 OR 17-4PH
75C	CAPSCREWS, BAIL	STAINLESS STEEL	AISI TYPE 316
90	MOTOR HOUSING	CAST IRON	A48 CL30
90A	STATOR	_____	_____
90B	HOLE COVER	STEEL	COMMERCIAL
90C	O-RING, HOUSING	RUBBER	BUNA-N
90D	CAPSCREW, HOUSING	STAINLESS STEEL	AISI TYPE 316
90E	GROUND SCREW	_____	COMMERCIAL
90F	TERMINAL BOARD ASSEMBLY	_____	_____
90H	LEADS, MOISTURE DETECTOR	_____	_____
90J	INSULATOR, SHRINK TUBE	POLYOLEFIN	COMMERCIAL
90K	O-RING, TERM BOARD	RUBBER	BUNA-N
90L	RETAINING RING, TERM BOARD	STEEL	COMMERCIAL
159	COVER, LOWER BEARING	CAST IRON	A48 CL30
159A	CAPSCREW, LOWER BEARING COVER	STAINLESS STEEL	AISI TYPE 316
163	BEARING, RADIAL	STEEL	COMMERCIAL
168	BEARING, THRUST	STEEL	COMMERCIAL
456A	INNER MECHANICAL SEAL	_____	_____
456B	OUTER MECHANICAL SEAL	_____	_____
202	COVER, HANDHOLE	CAST IRON	A48 CL30
202A	O-RING, HANDHOLE COVER	RUBBER	BUNA-N
202B	CAPSCREW, HANDHOLE COVER	STAINLESS STEEL	AISI TYPE 316

NOTES:

1. ALL MATERIAL SPECIFICATIONS ARE ASTM UNLESS OTHERWISE NOTED, AND ARE FOR DESCRIPTION OF CHEMISTRY ONLY.
2. OPTIONAL O-RING MATERIAL VITON AND OPTIONAL MECHANICAL SEAL MATERIALS ARE AVAILABLE.

MATERIAL SPECIFICATIONS
FAIRBANKS NIJHUIS
SUBMERSIBLE MOTORS

 **PENTAIR** FAIRBANKS NIJHUIS

DWG NO 24LYA3522E REV NO 6

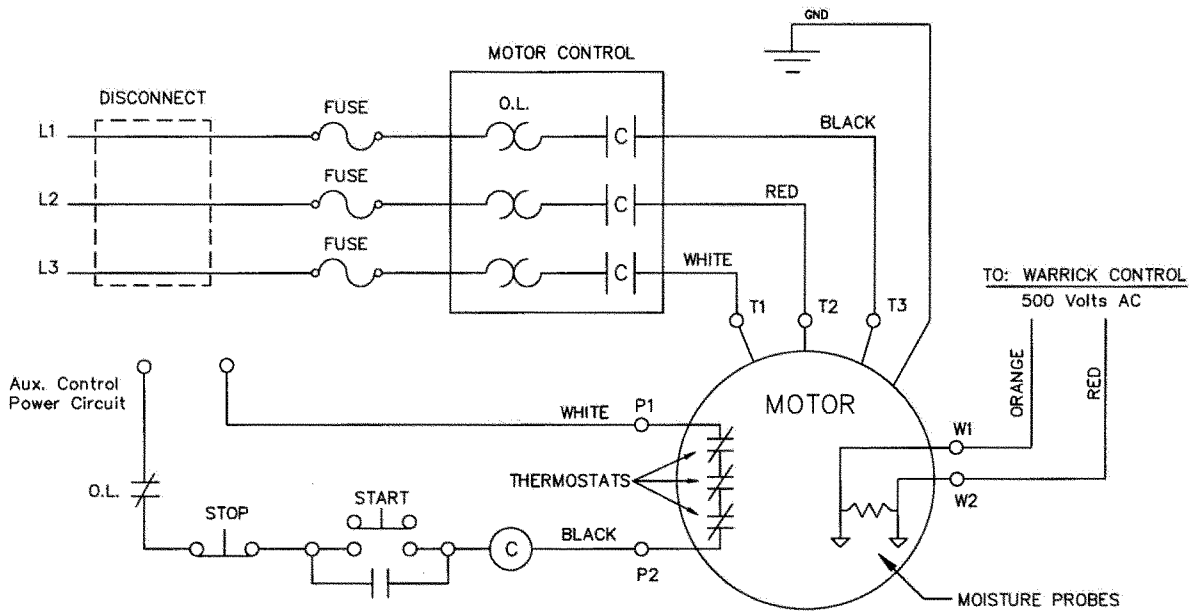

Figure 3

FAIRBANKS NIJHUIS
 SUBMERSIBLE MOTOR WIRING DIAGRAM
 210T, 220T FRAME MOTORS

PENTAIR FAIRBANKS NIJHUIS	
DWG NO	543MM001
REV NO	1

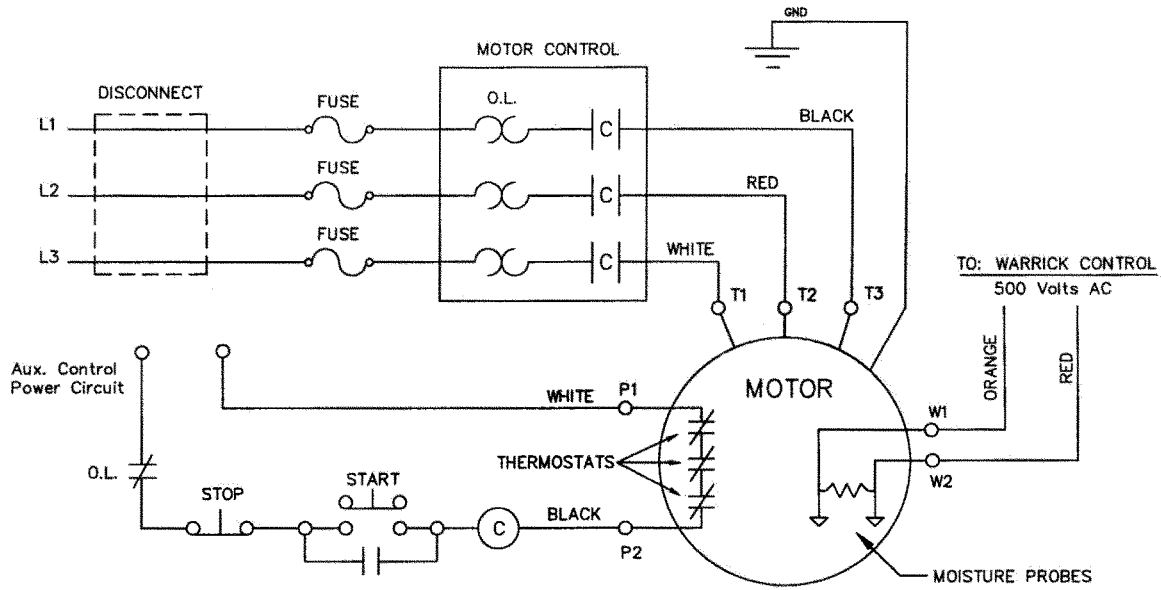

Figure 4

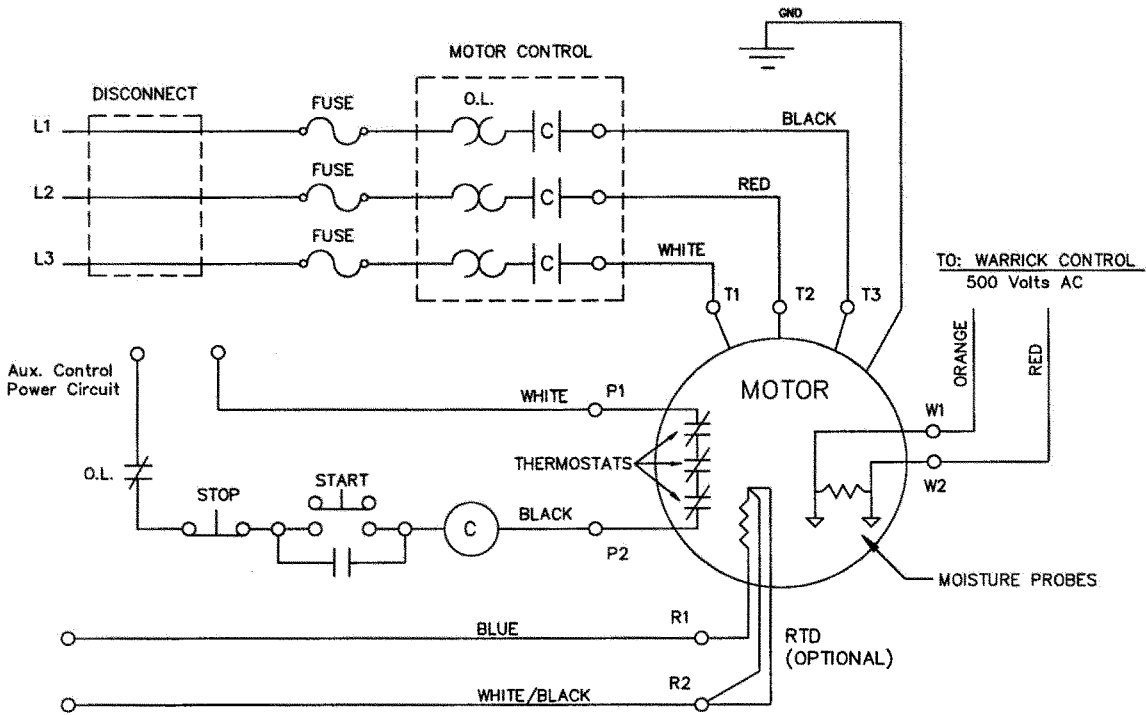
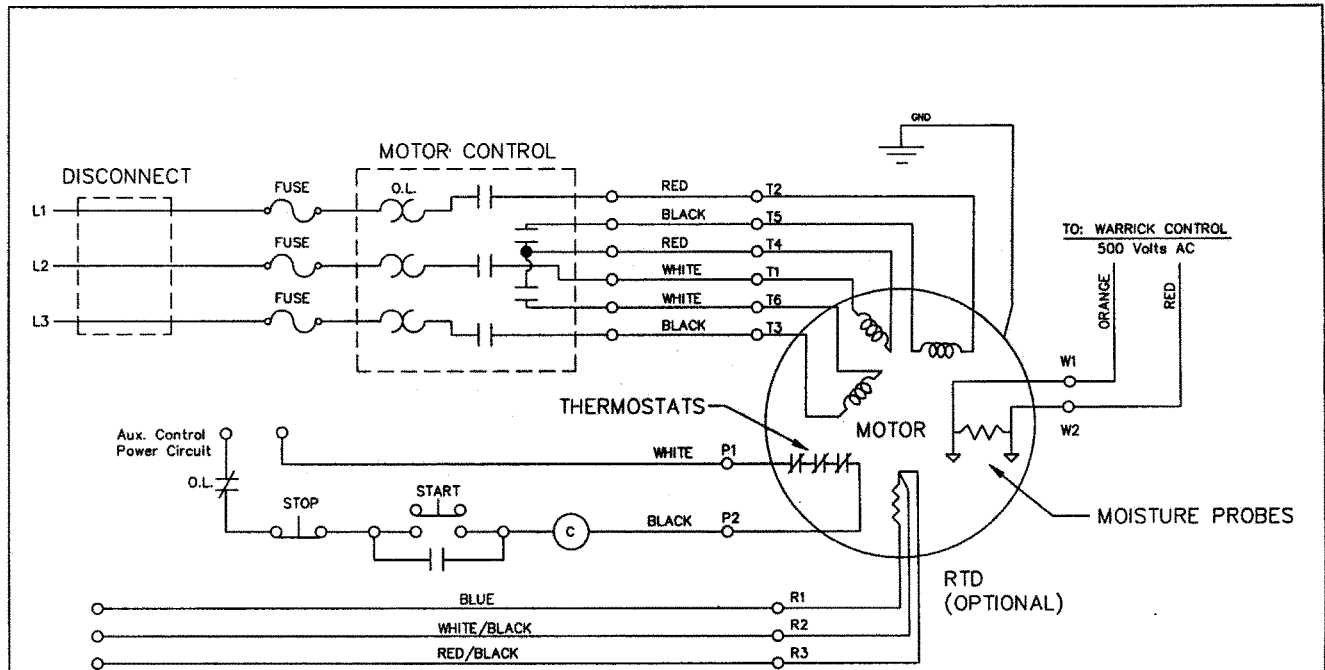

Figure 5

FAIRBANKS NIJHUIS
 SUBMERSIBLE MOTOR WIRING DIAGRAM
 250T, 320T & 360T/365T FRAME MOTORS

DWG NO	543MM002
REV NO	1



WYE--START DELTA RUN

Figure 6

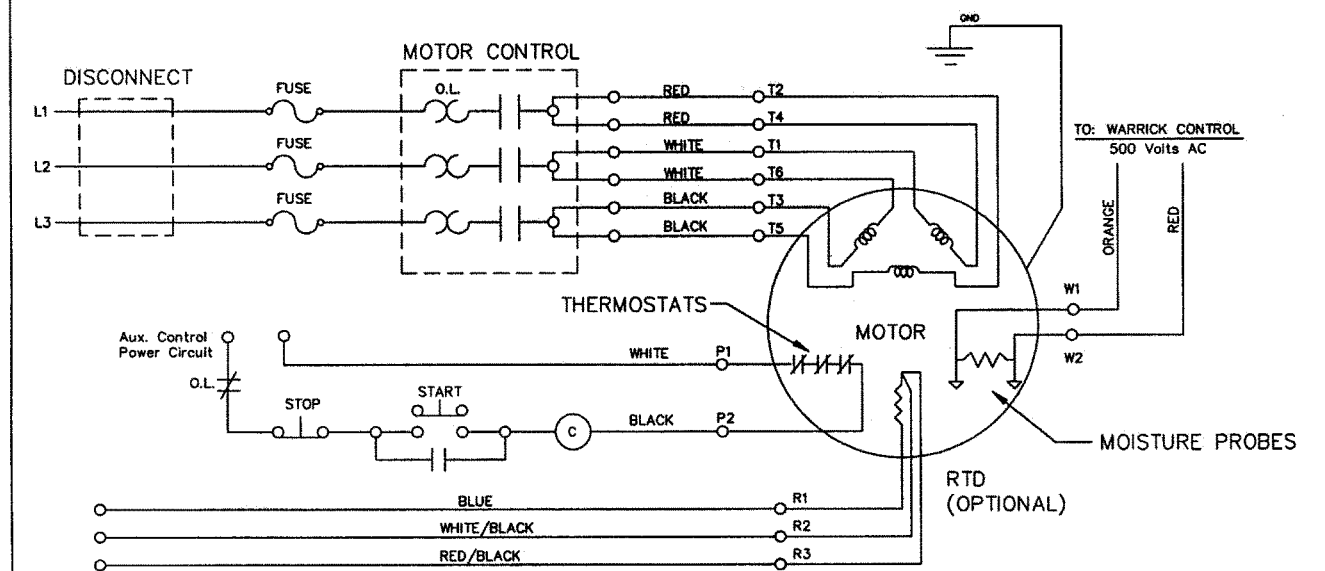

DELTA START DELTA RUN

Figure 7

FAIRBANKS NIJHUIS
 SUBMERSIBLE MOTOR WIRING DIAGRAM
 440T/445T & 490T/495T FRAME MOTORS

PENTAIR FAIRBANKS NIJHUIS
 DWG NO 543MM003 REV NO

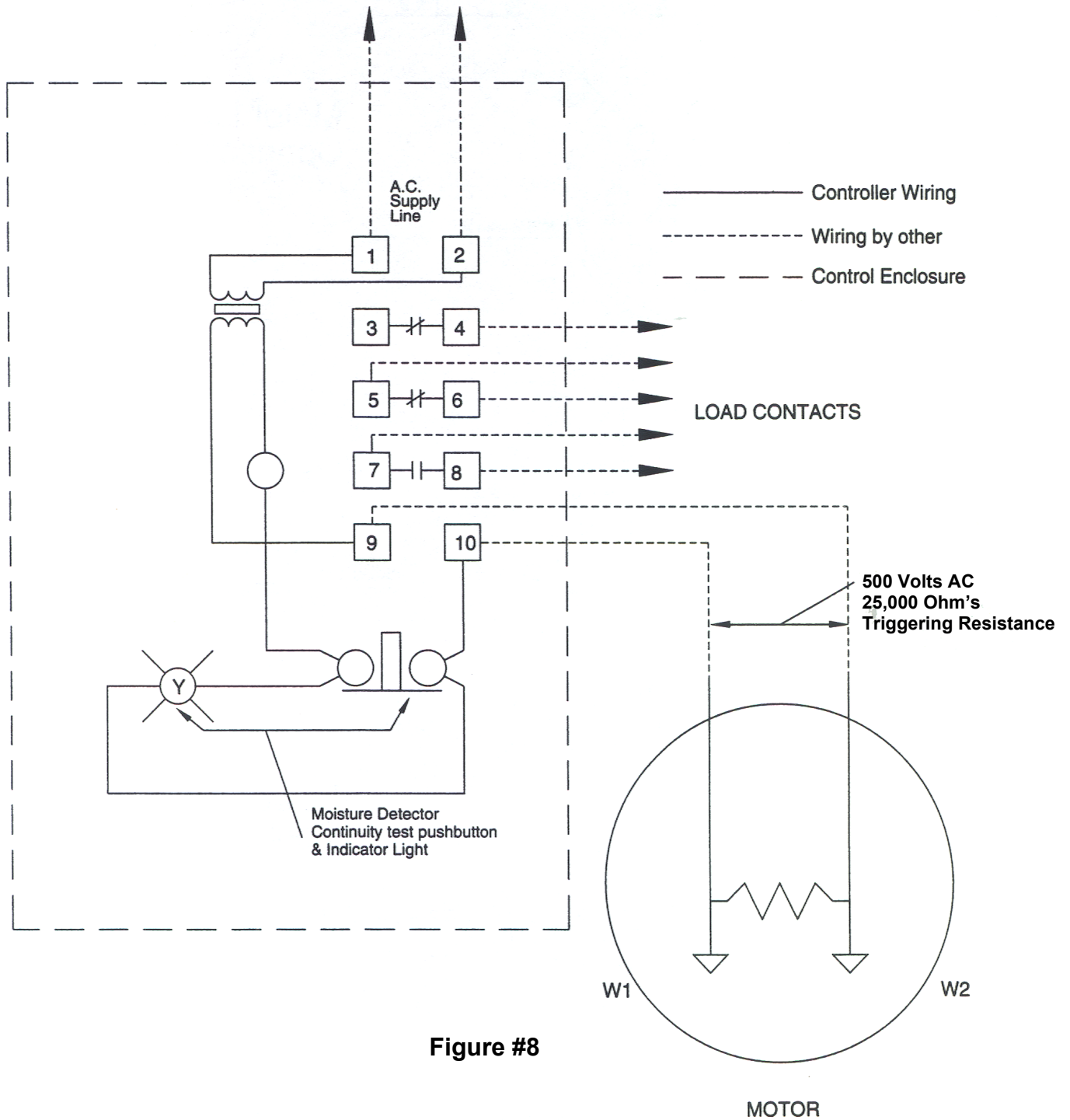
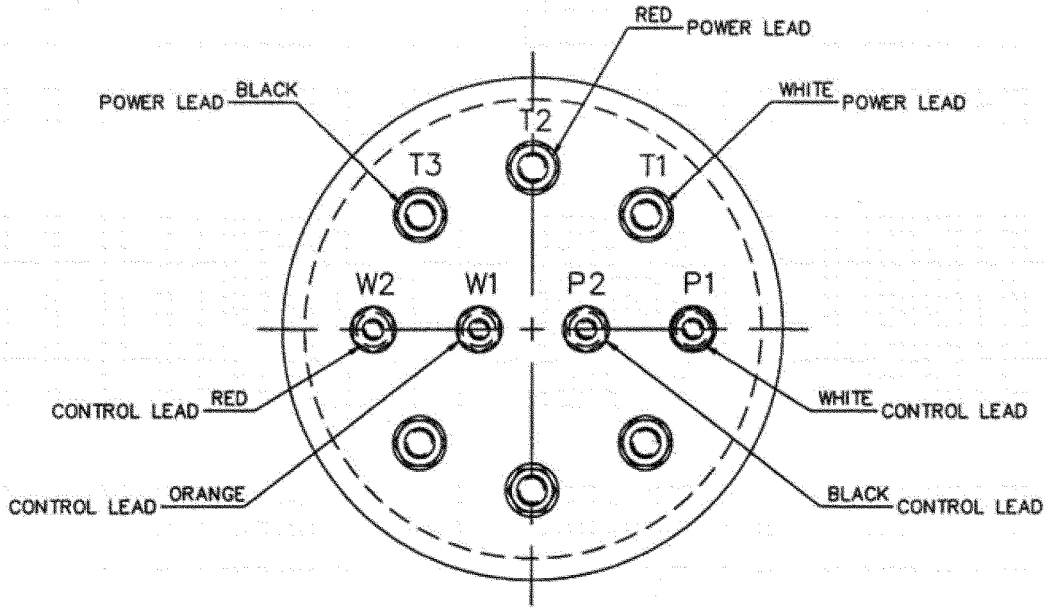
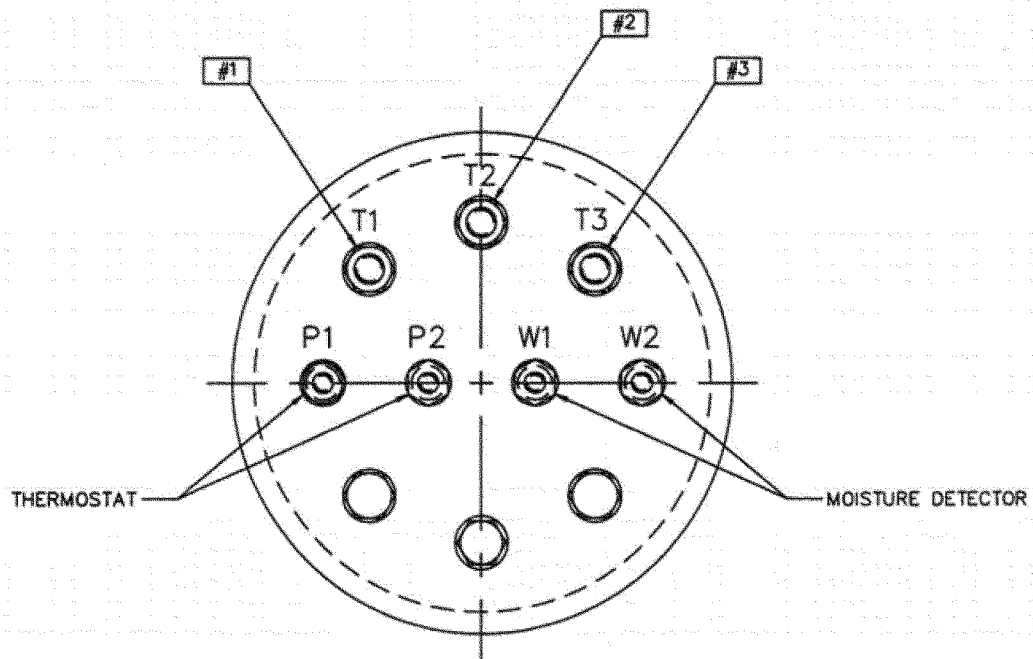

Figure #8

MOISTURE DETECTION CONTROLLER



CABLE LEAD SIDE CONNECTIONS
 FIGURE #7



MOTOR LEAD SIDE CONNECTIONS
 FIGURE #8

FAIRBANKS NIJHUIS TERMINAL BOARD CONNECTIONS 210T - 400T FRAME SINGLE VOLTAGE MOTORS	PENTAIR FAIRBANKS NIJHUIS
DWG NO 543MM015-4	REV NO 0

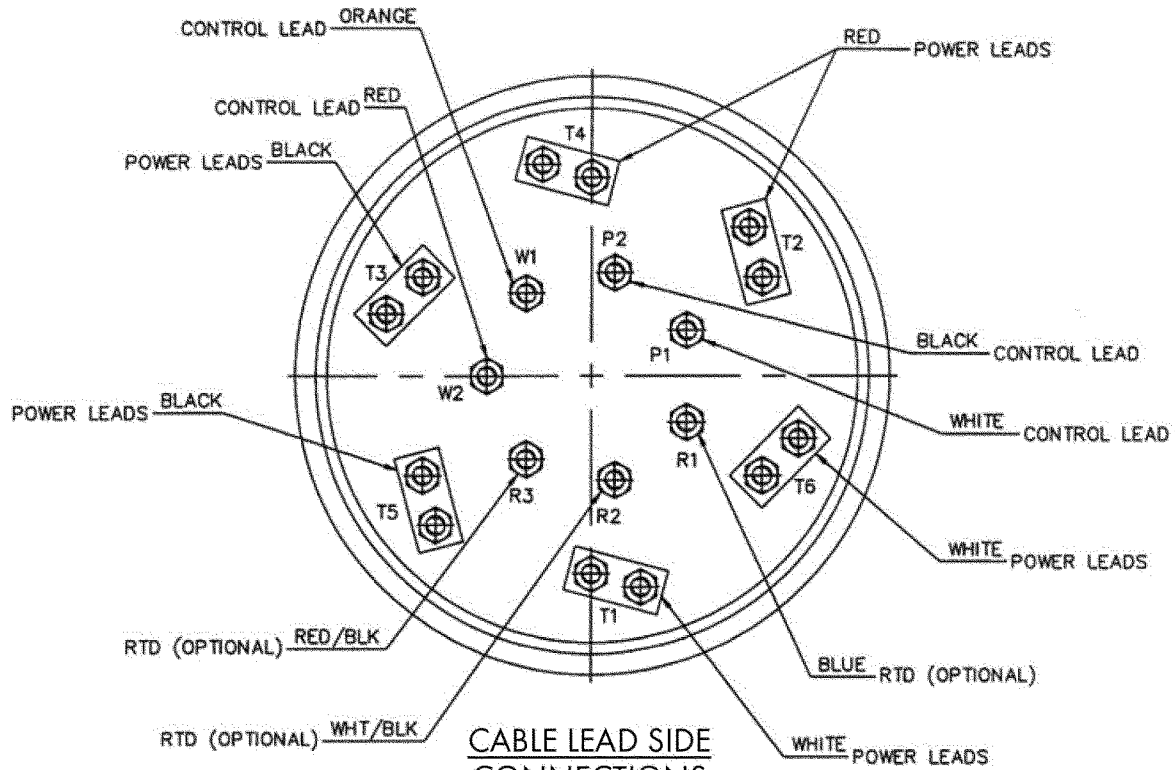

CABLE LEAD SIDE CONNECTIONS

FIGURE #9

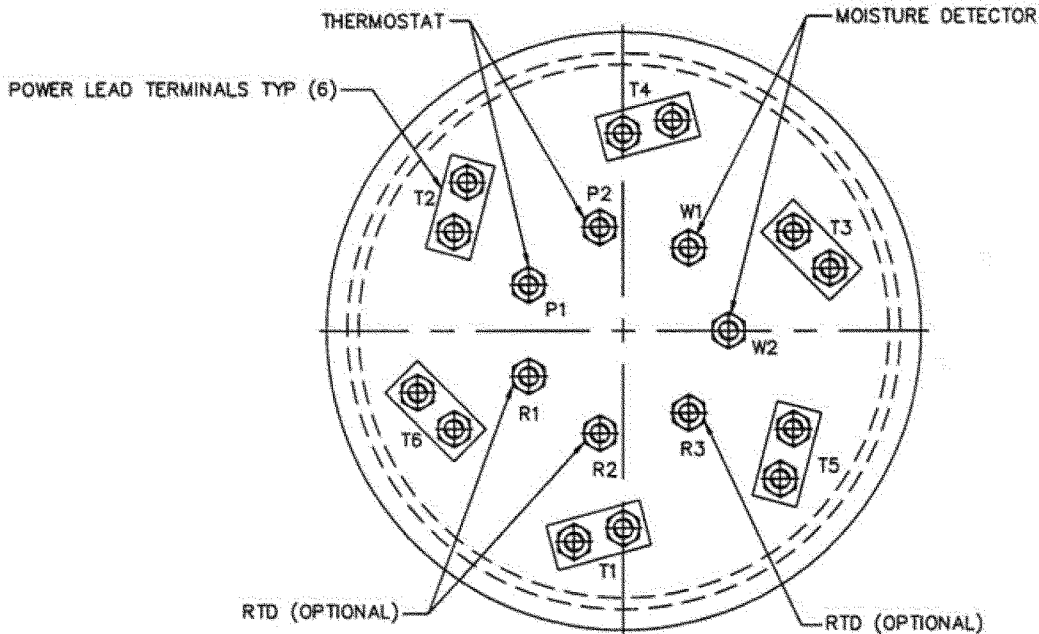

MOTOR LEAD SIDE CONNECTIONS

FIGURE #10

FAIRBANKS NIJHUIS
TERMINAL BOARD CONNECTIONS
440T - 445T FRAME MOTORS

PENTAIR FAIRBANKS NIJHUIS
DWG NO 543MM015-2 REV NO 0

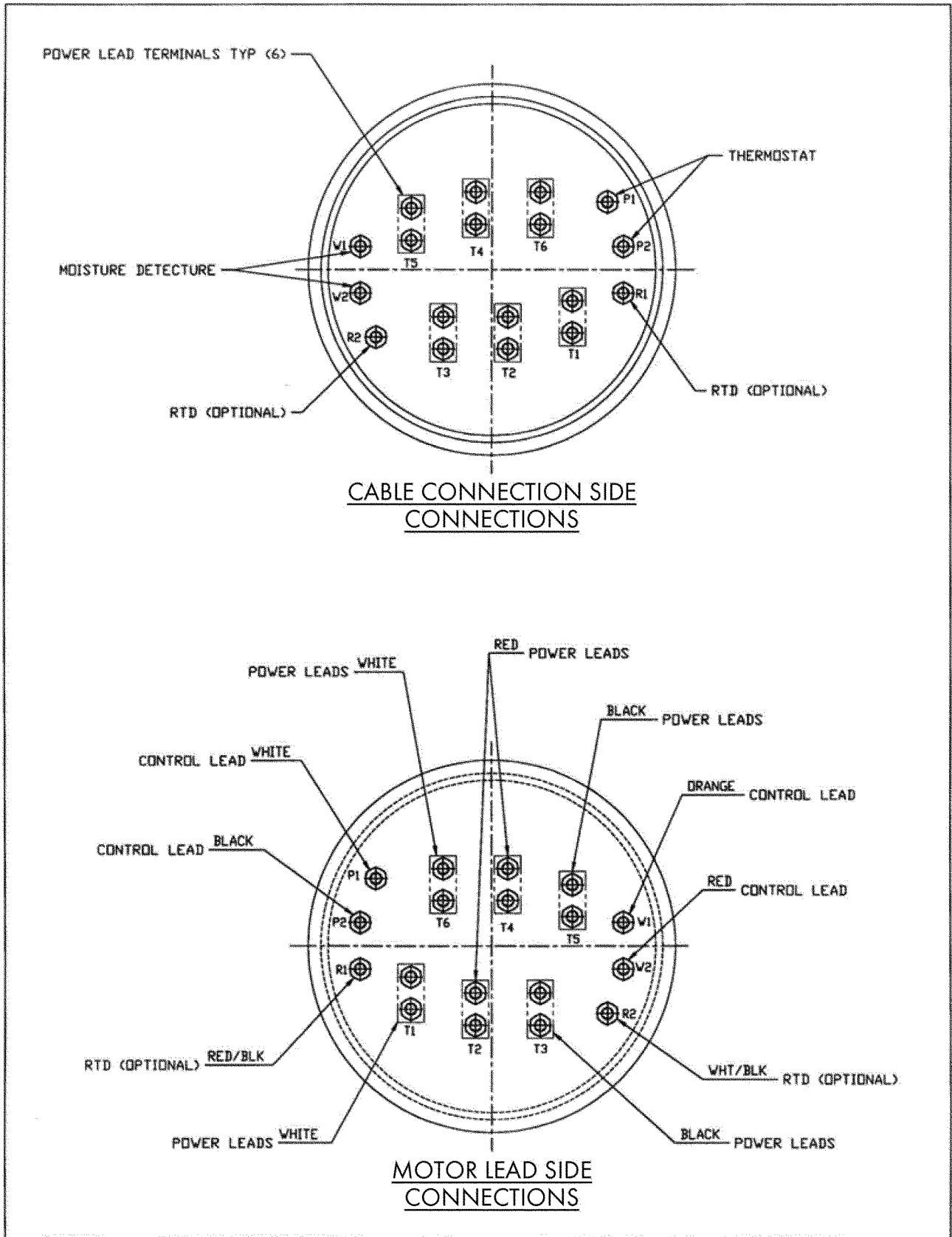

FAIRBANKS NIJHUIS TERMINAL BOARD CONNECTIONS 490T FRAME 460V MOTORS		PENTAIR FAIRBANKS NIJHUIS
DWG NO	543MM015-1	REV NO 0

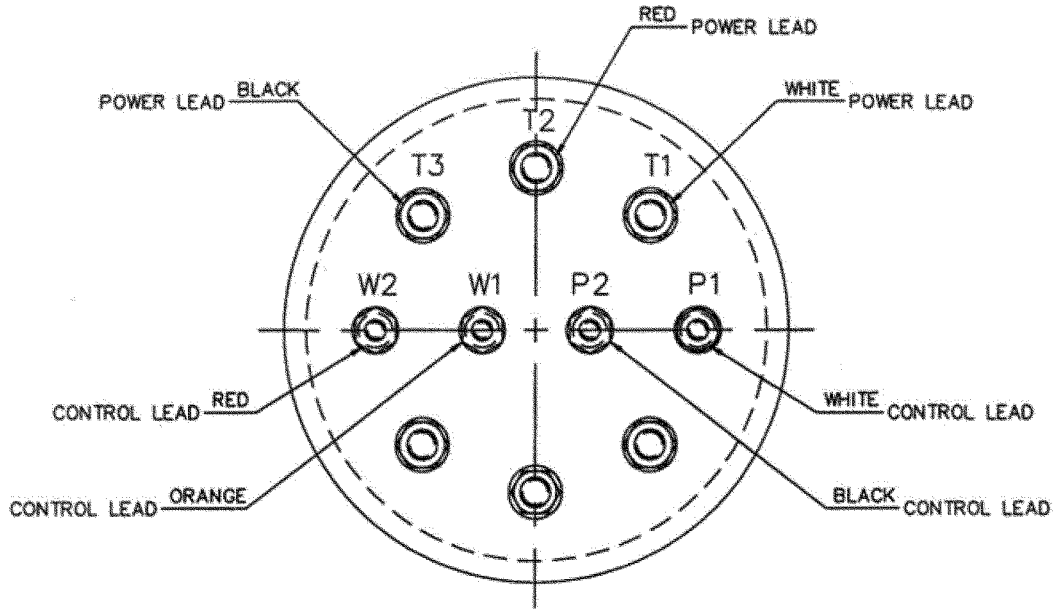

CABLE LEAD SIDE
CONNECTIONS
FIGURE #7

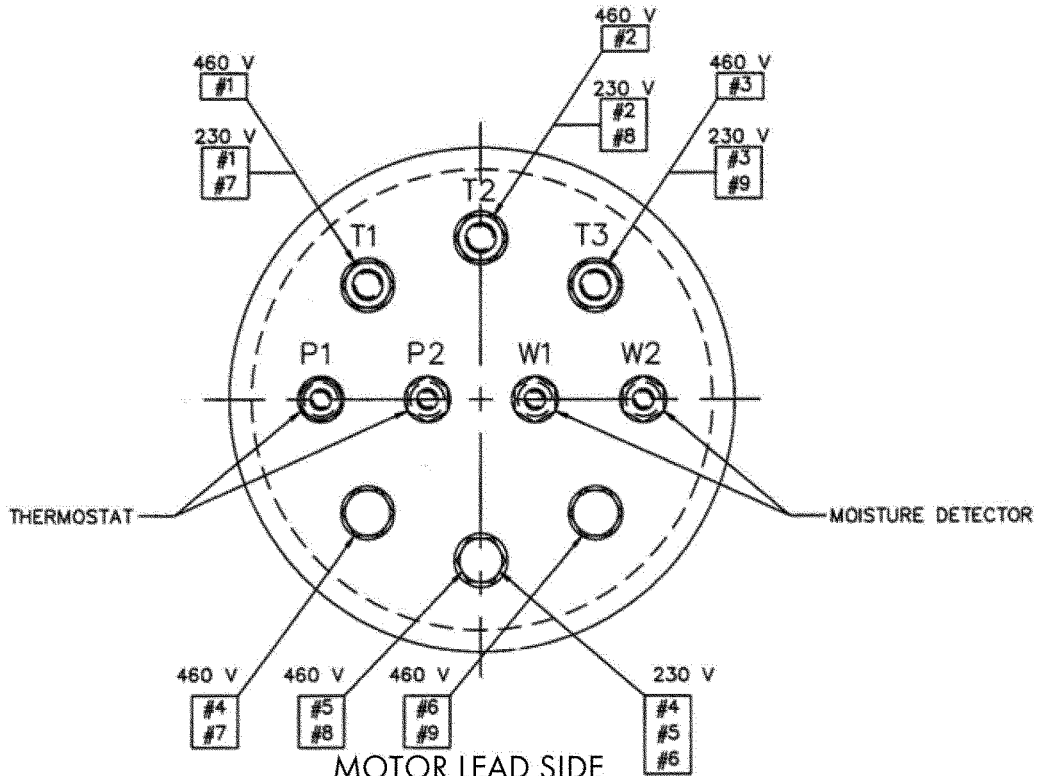

MOTOR LEAD SIDE
CONNECTIONS
FIGURE #8

FAIRBANKS NIJHUIS
TERMINAL BOARD CONNECTIONS, 3HP - 40HP,
210T - 320T FRAME DUAL VOLTAGE MOTORS

PENTAIR FAIRBANKS NIJHUIS

DWG NO 543MM015-3 REV NO 0

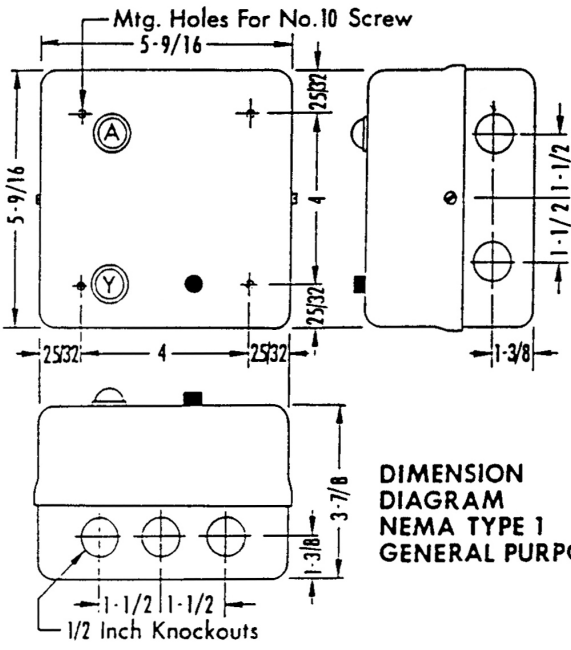
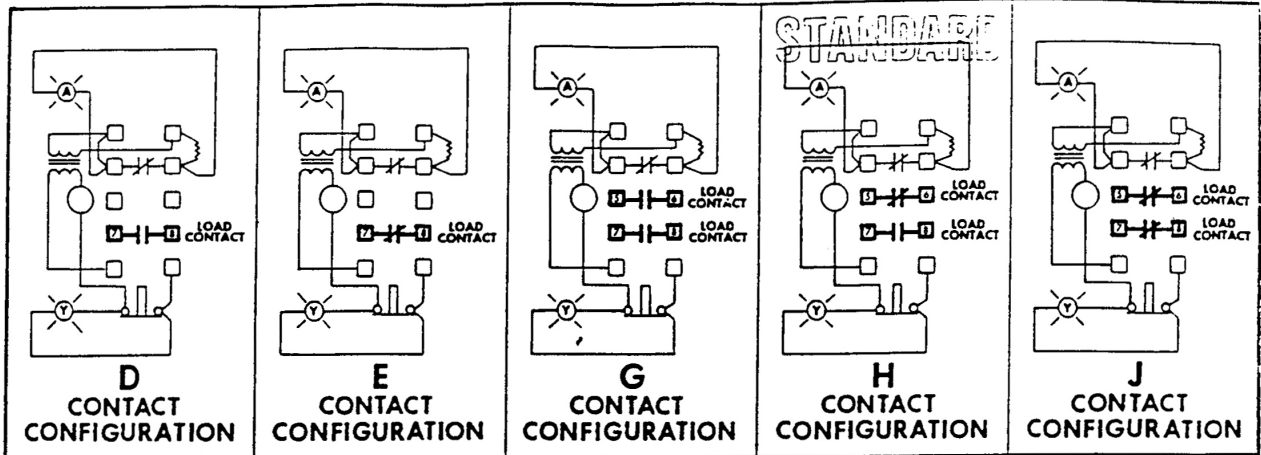

**DIMENSION DIAGRAM
 NEMA TYPE 1
 GENERAL PURPOSE**

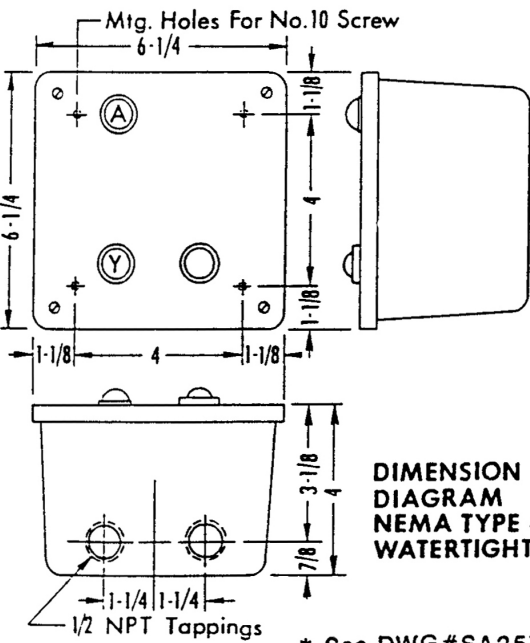

**DIMENSION DIAGRAM
 NEMA TYPE 4
 WATERTIGHT**

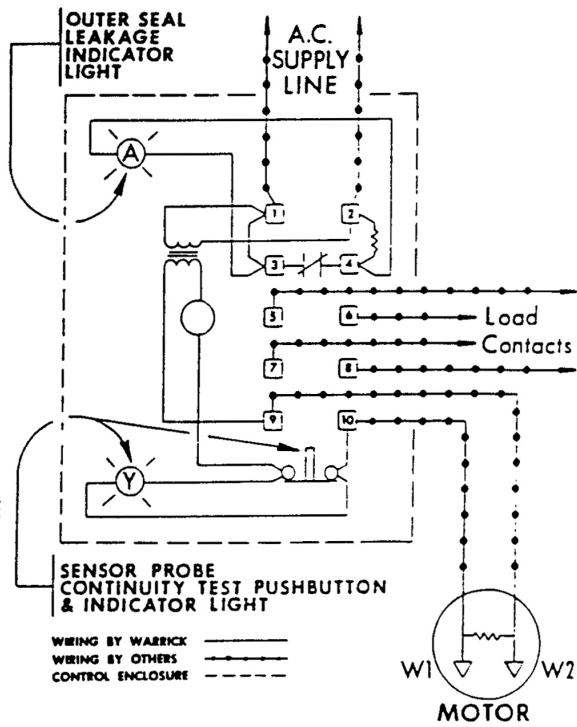

WIRING BY WARRICK ———
 WIRING BY OTHERS - - - - -
 CONTROL ENCLOSURE

TYPE 2 8 1 0

FORM

- ENCLOSURE TYPE
 1-NEMA1 or 4-NEMA4 or 4X-NEMA4X
- CONTACT CONFIGURATION
 D, E, G, H or J from diagrams at top
- SUPPLY LINE VOLTAGE
 1- 115VAC
 2- 230VAC
 4- 460VAC
 5- 575VAC

SUBMERSIBLE MOTOR MOISTURE DETECTION CONTROL	
DATE: MARCH 73 DRAWN BY: JW	
WARRICK CONTROLS, INC 4237 NORMANDY CT., ROYAL OAK, MI	
DWG NO:	B2810W1A

* See DWG#SA2579 for Dimensions of 4X

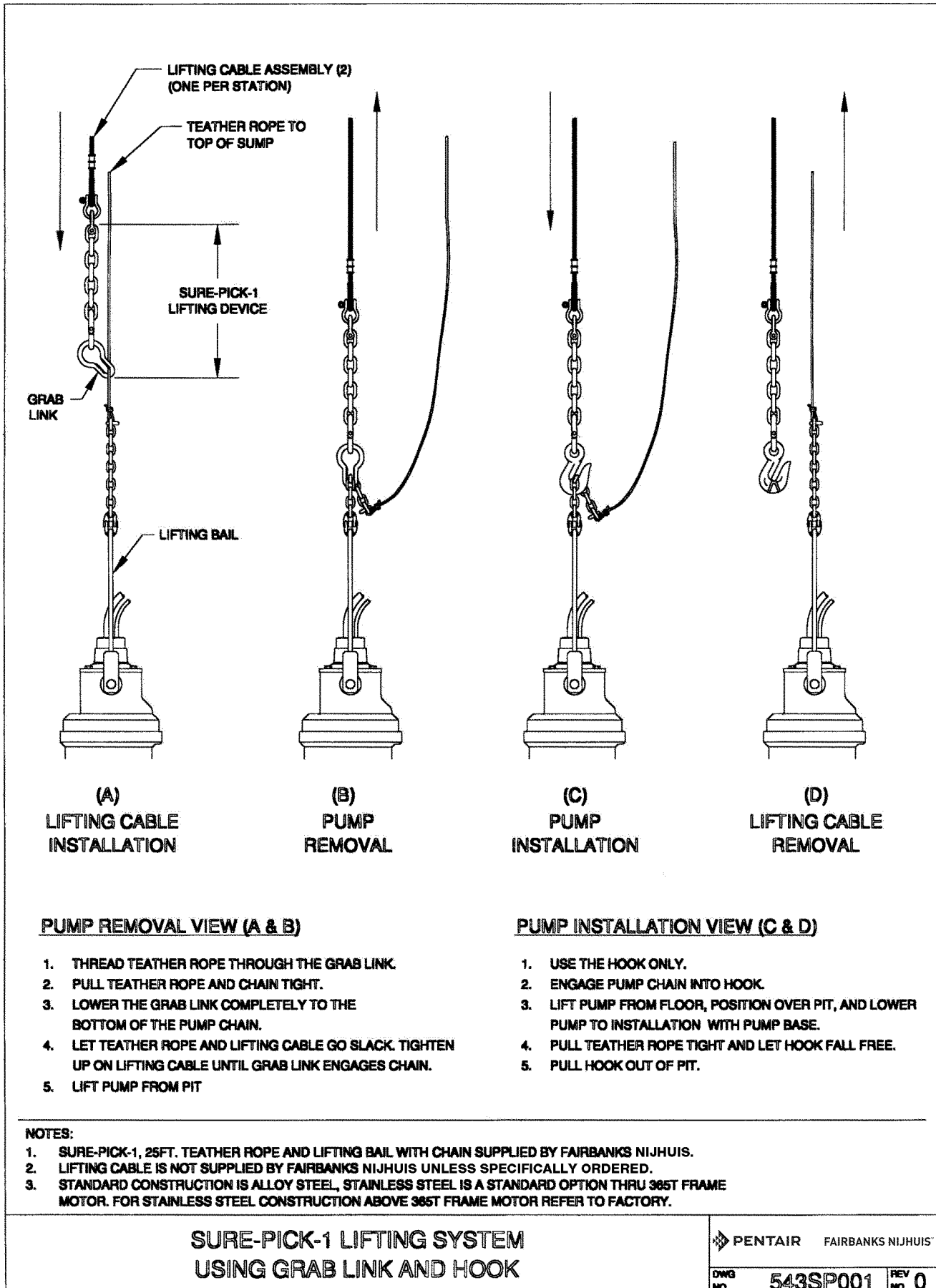

MT PUMP MODEL	FRAME	A (INCHES)	WEIGHT
2" D5431MT	210T	58 1/2	480
3" D5431MT	210T	58 1/2	480
4" D5431MT	210T	60	565
2" D5432MT	210T	58 1/2	555
3" D5432MT	210T	60	605
4" D5432MT	210T	64 1/2	730
4" D5432MT	250T	68 1/2	945
3" D5433MT	210T	60	710
3" D5433MT	250T	64	920
4" D5433MT	210T	61 1/2	760
4" D5433MT	250T	65 1/2	975
5" D5433MT	210T	69 1/2	880
5" D5433MT	250T	73 1/2	1065
6" D5433MT	210T	64 1/2	860
6" D5433MT	250T	68 1/2	1110
4" D5434MT	210T	62 1/2	940
4" D5434MT	250T	67	1140
5" D5434MT	210T	63	1080
5" D5434MT	250T	67	1295
5" D5434MT	320T	75 1/2	1790
6" D5434MT	210T	64 1/2	1180
6" D5434MT	250T	68 1/2	1395
6" D5434MT	320T	77	1845
6" D5434MT	360T	77 1/2	2285
6" D5434MT	365T	79 1/2	2360
6" D5434SMT	210T	72 1/2	1220
6" D5434SMT	250T	76 1/2	1435
6" D5434SMT	320T	85	1910
6" D5434SMT	360T	85 1/2	2350
6" D5434LMT	210T	72 1/2	1325
6" D5434LMT	250T	76 1/2	1540
6" D5434LMT	320T	85	2035
6" D5434LMT	360T	85 1/2	2460
4" D5435MT	210T	62 1/2	690
4" D5435MT	250T	66 1/2	1090
4" D5435MT	320T	75	1560
6" D5435MT	320T	80	2745
6" D5435MT	360T	80 1/2	3185
6" D5435MT	365T	82 1/2	3260
10" D5435MT	360T	89 1/2	3430
10" D5435MT	365T	91 1/2	3505
5" D5436MT	250T	69	1145
5" D5436MT	320T	77 1/2	1845
6" D5436MT	250T	72 1/2	1600
6" D5436MT	320T	81	2095
6" D5436MT	360T	81 1/2	2545
6" D5436LMT	320T	82	1820
6" D5436LMT	360T	82 1/2	2390
6" D5436LMT	365T	84 1/2	2435
6" D5436SMT	320T	81 1/2	2000
6" D5436SMT	360T	82	2440
6" D5436SMT	365T	84	2515
6" D5436MT	360T	77 1/2	3235
6" D5436MT	365T	79 1/2	3310

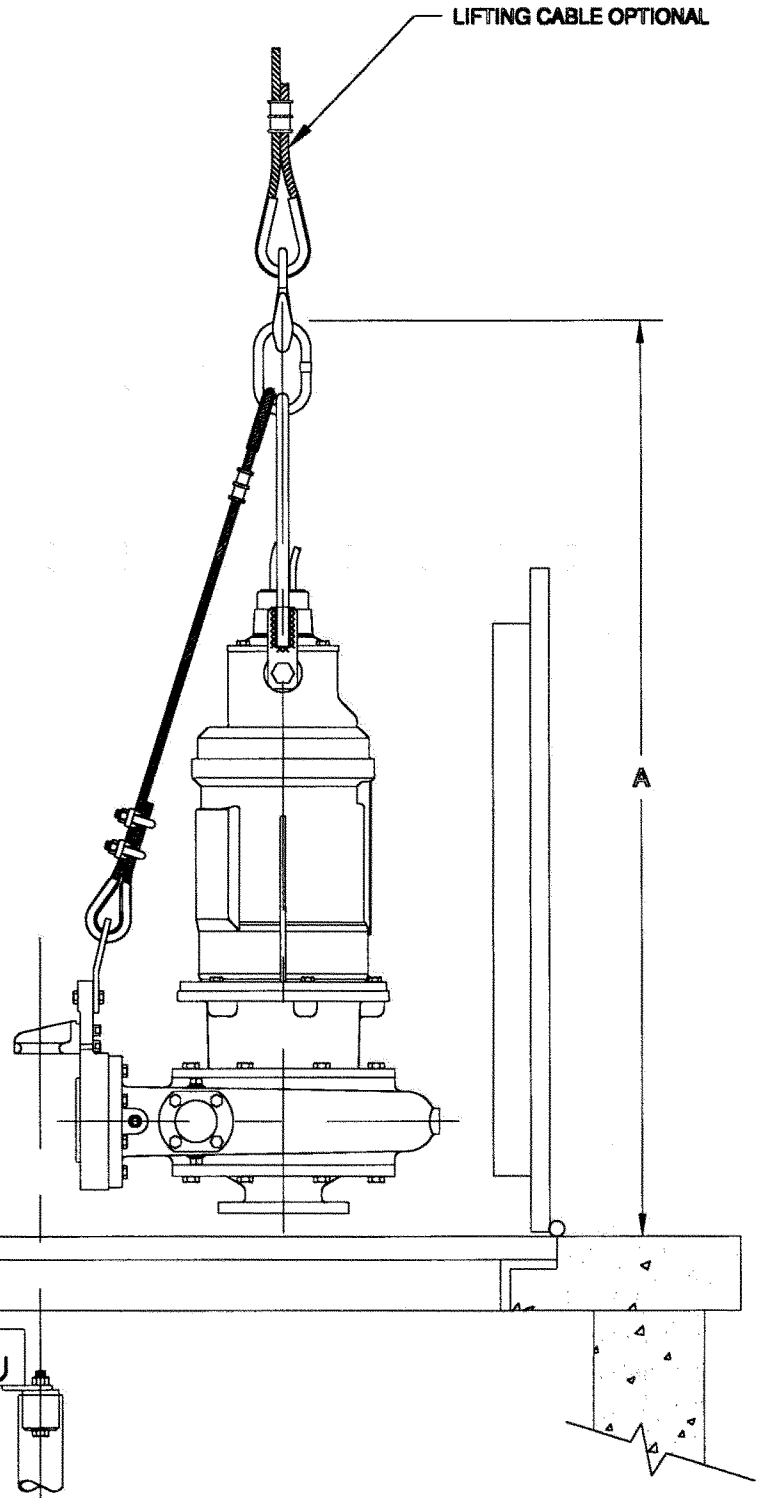

FMPC PUMP, MT (AS LISTED)
 MINIMUM LIFT-OUT CLEARANCE

PENTAIR FAIRBANKS NIJHUIS
 DWG NO 543MA142 REV NO 2

MT PUMP MODEL	FRAME	A (INCHES)	WEIGHT
4" D5433MT	320T	66	1470
5" D5433MT	320T	67	1585
6" D5433MT	320T	71	1610
4" D5434MT	320T	68 1/2	1660
4" D5434MT	360T	70	2140
4" D5434MT	365T	72	2215
5" D5434MT	360T	70	2235
5" D5434MT	365T	72	2310
6" D5435MT	400T	RTF	
10" D5435MT	400T	RTF	
5" D5436MT	320T	71 1/2	1845
5" D5436MT	360T	72	2245
5" D5436MT	365T	74	2320
5" D5436MT	400T	RTF	
6" D5436MT	365T	77 1/2	2620
6" D5436MT	400T	RTF	
6" D5436MT	440T	105 1/2	5295
6" D5436LMT	400T	RTF	
6" D5436LMT	440T	107 1/2	5060
6" D5436SMT	400T	RTF	
6" D5436SMT	440T	105 1/2	5140
6" D5436MT	400T	RTF	
6" D5436MT	440T	108 1/2	5885

MV PUMP MODEL	FRAME	A (INCHES)	WEIGHT
6" D5436MV	320T	RTF	
6" D5436MV	360T	RTF	
6" D5436MV	365T	RTF	
6" D5436MV	400T	RTF	
6" D5436MV	440T	RTF	

MV PUMP MODEL	FRAME	A (INCHES)	WEIGHT
4" D5432MV	210T	64	575
4" D5432MV	250T	58	585
4" D5433MV	210T	64 1/2	640
4" D5433MV	250T	58 1/2	660
4" D5433MV	320T	67	1530
6" D5433MV	210T	58	800
6" D5433MV	250T	62	1020
6" D5433MV	320T	70 1/2	1530
4" D5434MV	210T	57 1/2	790
4" D5434MV	250T	61 1/2	1005
4" D5434MV	320T	68 1/2	910
4" D5434MV	360T	69 1/2	1125
4" D5434MV	365T	71 1/2	910
6" D5434MV	210T	66	1010
6" D5434MV	250T	63	1225
6" D5434MV	320T	72	1750
6" D5434MV	360T	72	2190
6" D5434S MV	210T	58 1/2	1085
6" D5434S MV	250T	63 1/2	1280
6" D5434S MV	320T	72 1/2	1800
6" D5434S MV	360T	73 1/2	2240
6" D5434L MV	250T	62 1/2	1350
6" D5434L MV	320T	71 1/2	1850
6" D5434L MV	360T	72 1/2	2300
4" D5435MV	210T	57	750
4" D5435MV	250T	61	950
4" D5435MV	320T	70	1450
6" D5435MV	320T	76	2370
6" D5435MV	360T	77	2810
6" D5435MV	365T	79	2885
6" D5435MV	400T	RTF	
6" D5435MV	440T	111 1/2	5510
10" D5435MV	360T	86 1/2	3320
10" D5435MV	440T	116	6020
5" D5436MV	210T	RTF	
5" D5436MV	250T	RTF	
5" D5436MV	320T	RTF	
5" D5436MV	360T	RTF	
5" D5436MV	365T	RTF	
5" D5436MV	400T	RTF	

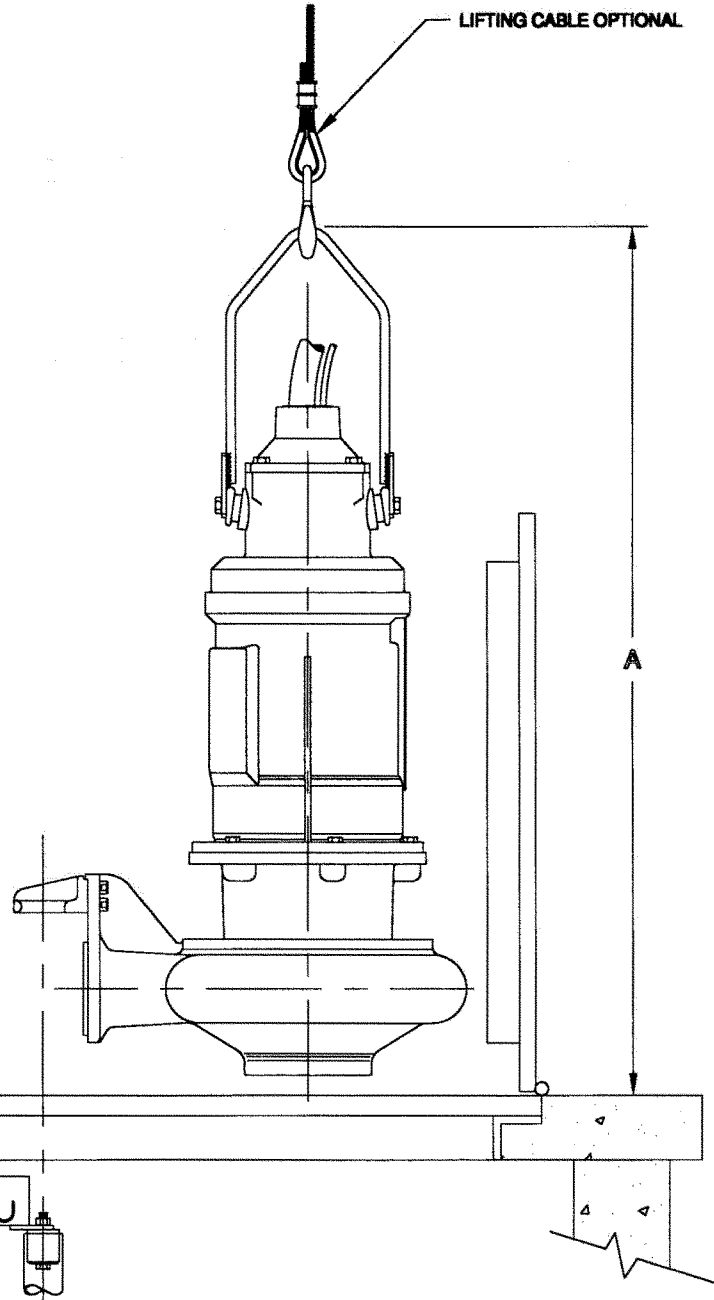

FMPC PUMP, MV (ALL) & MT (AS LISTED)
MINIMUM LIFT-OUT CLEARANCE

PENTAIR FAIRBANKS NIJHUIS™

DWG NO **543MA141** REV NO **4**

THIS PAGE INTENTIONALLY LEFT BLANK

THIS PAGE INTENTIONALLY LEFT BLANK

THIS PAGE INTENTIONALLY LEFT BLANK

