



Models EST12, EST24 and EST32 Installation and Maintenance Instructions

THE FOLLOWING ARE CAUTIONARY STATEMENTS THAT MUST BE READ AND FOLLOWED DURING BOTH INSTALLATION AND OPERATION

WARNING: *Raritan Engineering Company, Inc. recommends that a qualified person or electrician install this product. Equipment damage, injury to personnel or death could result from improper installation. Raritan Engineering Company, Inc. accepts no responsibility or liability for damage to equipment, or injury or death to personnel that may result from improper installation or operation of this product.*



WARNING: **HAZARD OF SHOCK AND FIRE** - Always use recommended fuse/circuit breaker and wire size.



WARNING: **HAZARD OF FLOODING** - Always shut off sea cocks before leaving boat unattended.



Double clamp all hose fittings below the waterline, check hose clamps frequently for integrity.

WARNING: *The electro scan operates on an Electrochemical principle. Introduction of any substance other than salt water, human waste, Raritan C.P. or toilet tissue may cause heat build up and extensive damage. If any other substance is introduced by accident, the electro scan must not be turned on until entire system is flushed out with water.*



electroscan with control



electro scan™ is a U. S. Coast Guard Certified Type I Marine Sanitation Device for use on inspected and uninspected vessels 65 feet (19.7 Meters) and under. It must be operated within areas that are not declared a Federal No Discharge Zone (NDZ) by the U.S. Environmental Protection Agency (EPA). This is applicable for all U.S. territorial waters inside the three mile limit. Other countries - check with local authorities.

electro scan is designed for recreational use and accommodates most marine toilets*. It can be used with one or, in some cases, two toilets. The electro scan is available in 12, 24 or 32 VDC.

The system consists of a Control Unit, LCD Display, System Status Panel and Treatment Tank.

Model and Serial

*for use with the VacuFlush® marine toilet manufactured by Sealand Technology, Inc., (See Application note L286)
VacuFlush® is a registered trademark of Sealand Technology, Inc.

Single Button operation -

Both toilet and electro scan are operated by one of the following options:

Option #1: Toilet Push Button - (recommended)

Flushing toilet will activate treatment cycle. Flush toilet as often as necessary until system status green light begins to blink, flush must not exceed 1.5 gallons.

Option #2: System status panel Touch Pad

"Start/Stop" button activates both the toilet and treatment cycle. **Note:** Toilet flush time is factory pre-set for 10 seconds and is adjustable, see "setting toilet flush time" on page 3

Independent Button operation -

Used with manual flush toilets or if electric toilet is being activated separately from electro scan. "Start/Stop" button must be pressed before toilet is flushed. Flush toilet as often as necessary until system status green light begins to blink. Flush must not exceed 1.5 gallons

Automatic Flush Sensor operation -

If purchased separately and installed the electro scan cycle will automatically start when manual toilet is flushed (part# 31-605)

To Stop Treatment Cycle -

Pressing "Start/Stop" again stops the treatment cycle, If wired per option #2 it will also stop the toilet from flushing.

Notes:

- 1) Total flush volume must not exceed 1.5 gallons (5.7 liters) per cycle.
- 2) Operating with red light for extended periods will damage electrode and void warranty.

Salt Feed System Options

IMPORTANT:

A salt feed tank is required when operating system with fresh or brackish water. Operating in low salt conditions without the addition of salt will shorten life expectancy of the electrode plate and will void warranty.

The following are available to purchase:

NOT FOR USE WITH PRESSURIZED FRESH WATER TOILETS:

Two Gallon (7.6 liters) Salt Feed Tank

(Part #31-3001) - Tank must be filled with a saturated salt solution which is dispensed via a T-check valve into incoming water. One system per toilet. For use in slightly brackish water. If used in fresh water tank will only last for approximately 15 flushes of the toilet.

Four Gallon (15.2 liters) Salt Feed Tank

(Part #31-3005) - Tank must be connected to pressurized fresh water and filled with solar salt. The saturated salt solution is dispensed via a T-check into incoming water. One system per toilet. Requires manual adjustment as water salinity changes.

OK FOR USE WITH PRESSURIZED FRESHWATER TOILETS:

Four Gallon (15.2 liters) Salt Feed Tank with Pump

(Part #32-3005 12 Volt and #33-3005 24 Volt) The tank must be connected to pressurized fresh water and filled with solar salt. The pump is controlled by the control box. This system can only be used with the electro scan. One system per electro scan. This is the most accurate system to use as the amount of saturated salt solution is controlled by the actual operating conditions of the electro scan.

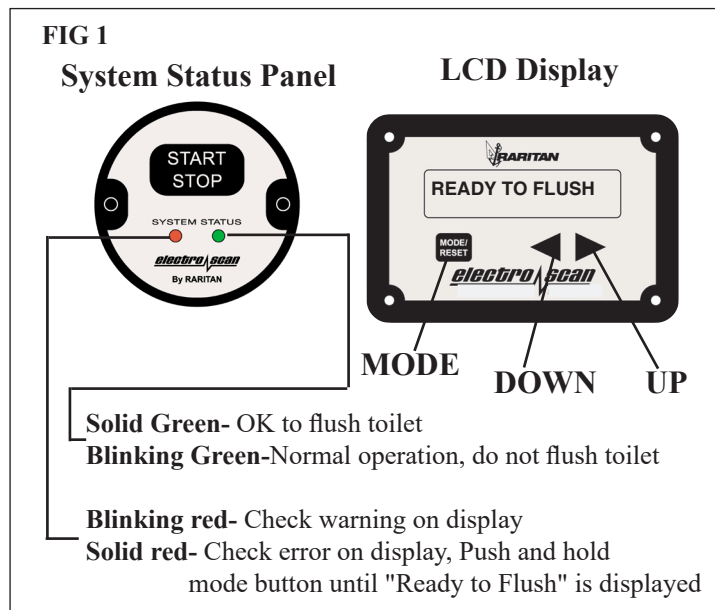

The **electro scan** has four basic components:

- **System Status Panel** - Begins treatment cycle and if wired, flushes an electric toilet at the same time (FIG 2).
- **Control Unit** - Serves as the systems central control. The unit contains three boards: **Main** (contains the power and logic components), **Microprocessor/Memory** (contains system program and stores operational data) and **I/O** (where connections are made for accessories).
- **Treatment Tank** - Consists of two chambers and electrode pack that temporarily converts saltwater into a powerful bactericide for the duration of the treatment cycle.
- **LCD Display** - Provides information during treatment cycle and summary of historical data. Also contains RESET button if system error occurs .

Setting time and date on LCD Display (FIG 4):

- Scroll to "time screen" using < and > keys when unit is not in cycle.
- Hold "mode" button until digits flash
- use < and > button to set hour in 24 hour time
- Push "mode" again for next digits (minutes)
- Use < and > to set minutes
- Repeat above until time and date are set
- Use < or > to move to next screen when no digits are flashing.

Setting toilet Flushtime on LCD Display (FIG5):

- Scroll to "flushtime" screen using < and > keys when unit is not in cycle.
- Hold "mode" button until digits flash
- Use < or > keys to set time in seconds for toilet 1
- Repeat above for toilet 2 (flushtime 2).

Toilet only flush:

Use only for servicing, storage or recommissioning. It is illegal to discharge untreated sewage in U.S. waters.

- Scroll to Flushtime (1 or 2) screen using < or > keys when unit is not in cycle.
- Hold "mode" button and press < or > key.
- Toilet will flush for set time.

FIG 2
System Status Panel



FIG 3
Control Unit

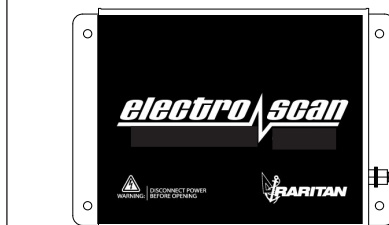

FIG 4
LCD Display

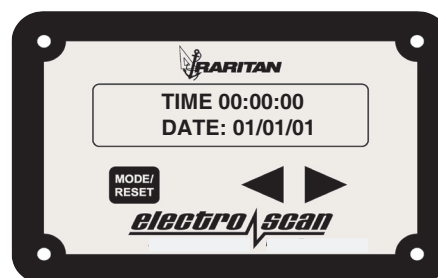
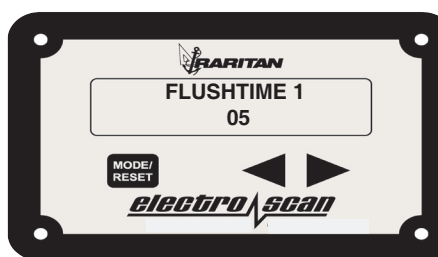

FIG 5
LCD Display



Most operation and troubleshooting information is displayed on the LCD display panel.

Following is the description of display screens and what they mean.

RED LED blinks for warning and is solid for errors

Display	Panel LEDs		Status
	Red	Green	
READY TO FLUSH	<input type="radio"/>	<input type="radio"/>	Previous cycle ended normally. Ready for next cycle
****WARNING**** VOLTAGE LOW	<input checked="" type="radio"/>	<input type="radio"/>	Previous cycle completed with low voltage, Ready for next cycle, low voltage should be corrected
****WARNING**** AMPS < 14	<input checked="" type="radio"/>	<input type="radio"/>	Previous cycle completed with low electrode amps, Ready for next cycle, low amps should be corrected .
PRETREATMENT VOLTAGE= 100%	<input type="radio"/>	<input checked="" type="radio"/>	Unit is in pretreatment cycle after start, voltage displayed.
TREATMENT VOLTAGE= 100%	<input type="radio"/>	<input checked="" type="radio"/>	Unit goes to treatment cycle after pretreatment for 120 seconds, voltage and amps are displayed alternately.
TREATMENT AMPS = 15	<input type="radio"/>	<input checked="" type="radio"/>	
****WARNING**** AMP = 10	<input checked="" type="radio"/>	<input type="radio"/>	During the treatment cycle if electrode amps drop below 14, Warning is displayed, and cycle is extended up to 240 seconds.
****WARNING**** VOLTAGE < 87%	<input checked="" type="radio"/>	<input type="radio"/>	During the entire cycle if voltage drops below 89% of full battery voltage, warning is displayed, cycle continues.

Treatment terminates in ERROR condition for reasons listed below. To clear error condition after corrective action is taken, hold mode/reset button on display until "Ready to Flush" is displayed.

*****ERROR**** LOW VOLTAGE	<input checked="" type="radio"/>	<input type="radio"/>	Voltage was less than 83% of full voltage during the cycle; check battery, connections and wire sizes.
*****ERROR***** LOW ELECTROD AMP	<input checked="" type="radio"/>	<input type="radio"/>	Electrode amps were lower than 7 amps, check salt, clean electrode per electrode cleaning page 5, check all connections.
*****ERROR***** MIX MOTOR OVERLD	<input checked="" type="radio"/>	<input type="radio"/>	Mixer motor amps high, refer to troubleshooting.
*****ERROR***** MAC MOTOR OVERLD	<input checked="" type="radio"/>	<input type="radio"/>	Macerator motor amps high, refer to troubleshooting.
*****ERROR***** ELECTROD OVERLD	<input checked="" type="radio"/>	<input type="radio"/>	Electrode amps were higher than 28 amps during fresh water operation, check for excessive salt, shorted electrode, wiring.
*****ERROR***** POS FUSE BLOWN	<input checked="" type="radio"/>	<input type="radio"/>	Positive/Negative fuse on I/O connection board is blown due to some external short, check toilet solenoid type, wiring to solenoid.
*****ERROR***** NEG FUSE BLOWN	<input checked="" type="radio"/>	<input type="radio"/>	Solenoid (relay) to toilet must be isolated coil type or Raritan solenoid part # CDS12 (for 12V)

Following screens can be seen by scrolling up (>) and down (<) keys. These screens display historical summaries of the data and allow setting of clock and flush timers

TIME 00:00:00 DATE: 01/01/00	FLUSHTIME 1 05	FLUSHTIME 2 10	NUMBER OF CYCLES 00100	CYCLE W/O LST 000
NUMBER OF RESETS 00	LOW AMP 14-18 000	LOW AMPS 7-14 000	LOW AMP SHUTDOWN 000	LOW VOLTS < 90% 05
LOW VOLT < 83% 01	LOW VOLT SHUTDOWN 05	MIN TEMPERATURE 20° F	MAX TEMPERATURE 90° F	

Cleaning Instructions

IMPORTANT: Do not use bowl cleaners that contain ammonia, ethyl acetate, phosphoric acid or concentrated chlorine bleach. C.P. is the only toilet bowl cleaner recommended by Raritan part # 1PCP22

WARNING: If the treatment system is activated with these cleaners, serious damage to the system will occur.

Recommended Visual Inspection

- ✓ Leaks at hose connections
- ✓ Hose clamps
- ✓ Condition of hoses
- ✓ Seacocks
- ✓ Condition of wires and connections

Treatment/Electrode cleaning

Note: Cleaning is recommended every SIX MONTHS or if red light and warning for low electrode amps are always on during treatment cycle.

WARNING: electro scan must not be activated without disconnecting electrode and motor wires while cleaning solution is in the system.

Raritan recommends using our product: C.H. Cleans Hoses for cleaning the electro scan. Part # 1PCHGAL, instructions for use with electro scan on label of C.H.

OPTIONAL MURIATIC ACID TREATMENT:

1. Activate the electro scan and flush toilet several times, allowing all waste to be treated.
2. Turn off water supply and flush toilet as dry as possible.

NOTE: Check toilet manufacturer's instructions to ensure no damage is done to any components.

3. Turn Power off
4. Disconnect red, white and orange wires at electro scan control box.
5. In plastic bucket combine 1.5 pints (.852 liters) of muriatic acid with 3 gallons (13.635 liters) of fresh water.
6. Carefully pour solution into the toilet and flush until bowl is as dry as possible.
7. Pour one gallon (3.8 liters) of additional fresh water into bowl to dilute any acid remaining.
8. Allow to stand for a **maximum** of 45 minutes.
9. Turn on water supply and flush only the toilet a minimum of 10 gallons (38.0 liters) of water to dilute and discharge muriatic acid solution.
See Page 3 OPERATION Toilet only flush (if using one button operation)
9. Reconnect wires and turn power on to electro scan.

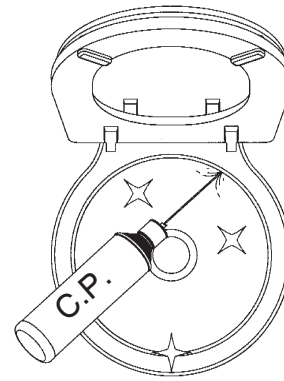

Using Raritan's C.P. Cleans Potties, a bio-enzymatic toilet bowl cleaner, will keep the bowl clean and fresh smelling and won't damage the treatment system.

Storage

Short Term - If system will not be used for a week, flush toilet and run treatment cycle several times.

Long Term - If system will not be used for several weeks, flush toilet and run treatment cycle several times. Then flush freshwater into system. Prior to use - flush toilet several times to re-fill treatment tank with ocean salinity salt water.

Refer to Recommissioning & Start-Up to initialize the system after storage (page 6)

IMPORTANT

- **Improper winter lay up is a major cause of failure due to freezing or buildup.**

Steps

1. Flush toilet and activate electro scan several times to clean out hoses and tank.
2. Turn off water supply and flush toilet as dry as possible.

NOTE: Check toilet manufacturer's instructions to ensure no damage is done to any components.

3. Turn off power and disconnect wires to electro scan.
4. Close seacocks.
5. Slowly open cross-over plug (FIG 6).

Caution: Open plug slowly as unit may be under pressure.

5. Using a pump and 3/8" tube, remove water from each side of partition in treatment tank through crossover plug.
6. Disconnect and drain hoses.

Recommissioning & Start-Up

1. Reconnect hoses and open seacocks.
2. Reconnect wires and turn power on.

NOTE: electro scan treatment tank must be full with **ocean water salinity, 3.5% salt water** before activating a cycle.

3. Flush toilet using one of the following methods to fill the treatment tank with salt water.
 - Scroll to Flushtime (1 or 2) screen using < or > keys when unit is not in cycle. Hold "mode" button and press < or > key. Toilet will flush for set time.
 - Separate operation - flush toilet allowing three gallons of water to pass into electro scan.
 - if toilet operates electro scan - you must disconnect power from electro scan while flushing to allow three gallons (13.6 liters) of water to pass into electro scan.

NOTE: In fresh and brackish water operation, salt content of treatment tank must be ocean water salinity prior to using unit for treatment. Ocean water salinity is 3.5% or approximately four ounces of salt to one gallon of water (32g/liter).

4. Inspect all connections for leaks.
5. System is ready for use.

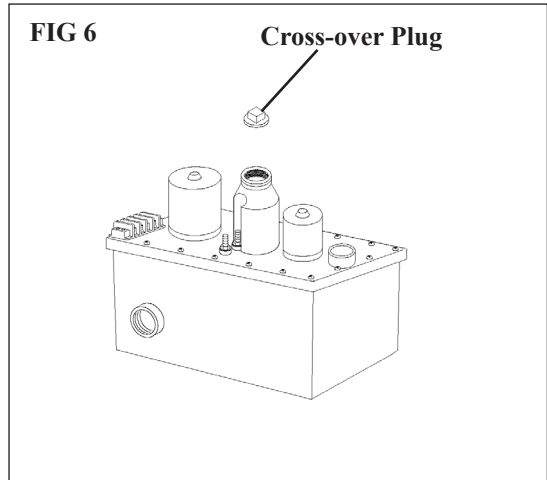

How the electroscan works -

Each time the toilet is flushed an equal amount of previously treated waste is discharged. The flushing action of the toilet moves the waste through the electro scan and out. The first chamber macerates to reduce particle size. The second chamber mixes to ensure uniform treatment of contents. The tank is always full and with proper ocean salinity, 3.5% salt, the electricity applied to the electrodes creates a strong bactericide to kill viruses and bacteria. When first activated both motors come on and run for the entire cycle. The user then has 35 seconds to flush toilet. After 35 seconds the electrode is energized to begin the treatment process which lasts for approximately 2 minutes.

Note: If the Red LED (EST models) is flashing during treatment, the cycle has been automatically extended to ensure proper treatment. The unit MUST not be operated in extended cycle for long periods as damage to electrodes will occur. Immediately attempt to determine the cause and fix a red light condition.

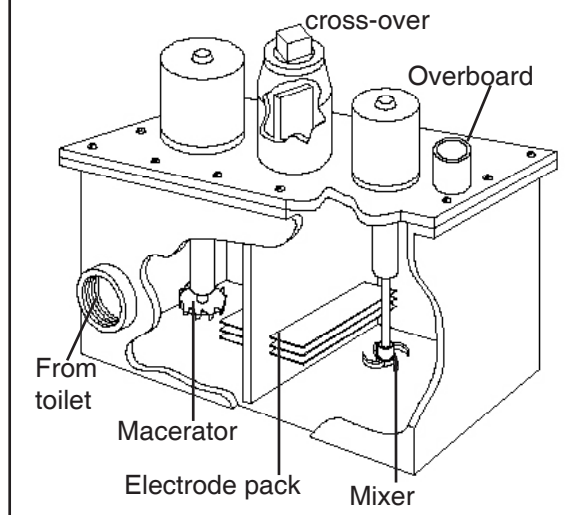

U.S.C.G. Type I MSD Certification #159.015/0107/1

Maximum Roll/Pitch Angle: 30° Capacity: 575 Gallons Per Day

Maximum Temperature Exposure: 120° F (49° C)

Minimum water temp: 50° F (10° C)

Maximum Total Flush Volume: 1.5 gallons/flush (5.7 liters/flush)

Maximum cable length for LCD Display: 16' (5M)

Maximum cable length system status panel: 50' (15.24M)

NOTES FOR WIRING:

1. Distances are from source to unit and back to source
2. Recommended conductor wire minimum AWG (mm²) for 3% voltage drop
3. Recommended conductor sizes are based on 105°C rated insulation. Refer to ABYC Standards for other insulation ratings.

Recommended Wire and Fuse/Circuit Breaker Size

Units Voltage	Circuit Breaker/fuse size (amps)	Amp. draw @ nominal voltage	10 feet	15 feet	20 feet	25 feet	30 feet	40 feet	50 feet
12 VDC	60	37	6 AWG	6 AWG	4 AWG	4 AWG	2 AWG	2 AWG	1 AWG
24 VDC	50	27	10 AWG	8 AWG	6 AWG	6 AWG	6 AWG	4 AWG	4 AWG
32 VDC	50	25	12 AWG	10 AWG	10 AWG	8 AWG	8 AWG	6 AWG	6 AWG

Electronic trip Overload settings

	12 VDC Trip point / Fuse Maximum amperage	24 VDC Trip point / Fuse Maximum amperage	32 VDC Trip point / Fuse Maximum amperage
Mixer Motor	9 amps / 35 amps 5 amp draw	9 amps / 35 amps 4 amp draw	9 amps / 35 amps 4 amp draw
Electrode Pack	35 amps / 35 amps 25 amp draw	35 amps / 35 amps 22 amp draw	35 amps / 35 amps 22 amp draw
Macerator Motor	30 amps / 35 amps 20 amp draw	30 amps / 35 amps 16 amp draw	30 amps / 35 amps 9 amp draw

CONVERSIONS								
Wire - AWG to mm ²								
AWG	16	14	12	10	8	6	4	2
mm ²	1.5	2.5	4.0	6.0	10.0	16.0	25.0	35.0
Feet to Meters								
Feet	10	15	20	25	30	40	50	
Meter	3.1	4.6	6.1	7.6	9.2	12.2	15.2	

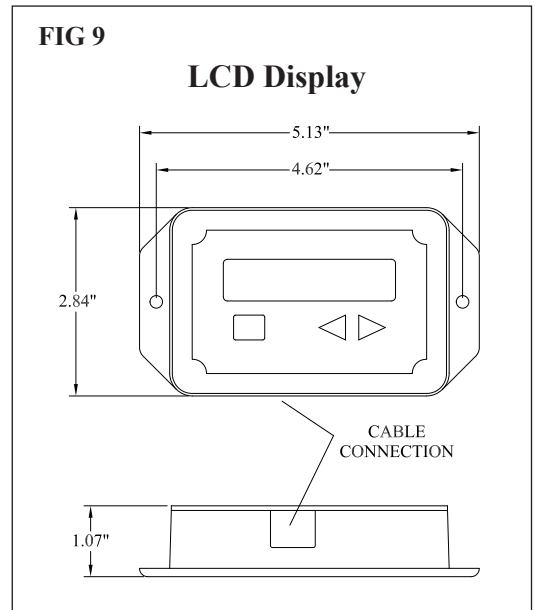
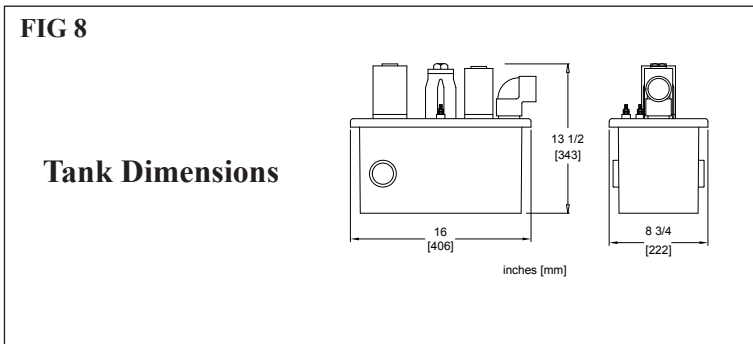
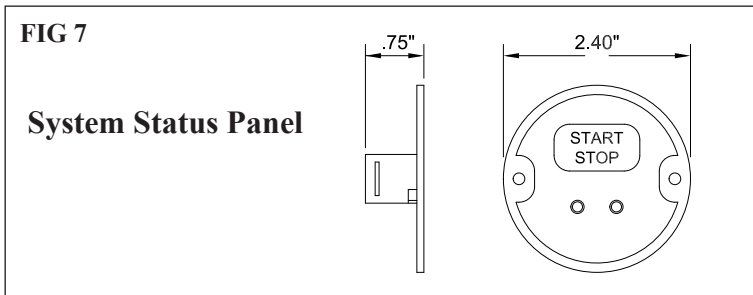

Parts Included with the electro scan

- 1 1/2" hose adapters (2)
- 1 1/2" NPT Intake Plug
- 90° 1 1/2" slip PVC fitting
- Treatment tank
- System status panel, control unit, LCD display, cables
- Wiring harness between control unit and tank

Optional Parts available for purchase:

- Dual Control - Part# ESTDC
- Salt Feed Systems - See Page 2 for part #'s
- Manual head sensor for automatic activation (Raritan part# 31-605)

Parts Required (not included)

- PTFE tape or non-permanent thread sealing compound
- PVC Cement, PVC Cleaner
- 1 1/2" (3.8 mm) I.D. sanitation hose (Raritan part # SFH)
- Hose clamps
- 1" (2.54 cm) x 1" (2.54 cm) wood strips and fasteners to secure to floor (wooden frame)
- 3/4" (1.9 cm) strapping
- Electrical connections, wire and fuse or circuit breaker
- Strain relief clamps

NOTE: Discharge of raw, untreated sewage is prohibited in all U.S. waters inside the three mile limit except in the Gulf of Mexico where the limit is nine miles. "Y" valves, if installed, must direct toilet discharge to a U.S.C.G. approved treatment system or holding tank and must be secured in that position while inside the three-mile limit.

The EPA standards state that in freshwater lakes, freshwater reservoirs or other freshwater impoundments whose inlets or outlets are such to prevent the ingress or egress by vessel traffic subject to this regulation, or in rivers not capable of navigation by interstate vessel traffic subject to this regulation, marine sanitation devices certified by the U.S. Coast Guard installed on all vessels shall be designed and operated to prevent the overboard discharge of sewage, treated or untreated, or any waste derived from sewage. The EPA standards further state that this shall not be construed to prohibit the carriage of Coast Guard-certified flow-through treatment devices which have been secured so as to prevent such discharges. They also state that waters where a Coast Guard-certified marine sanitation device permitting discharge is allowed including coastal water estuaries, the Great Lakes and interconnected waterways, freshwater lakes and impoundments accessible through locks, and other flowing waters that are navigable interstate by vessels subject to this regulation (40 CFR 140.3)

MOUNTING

Treatment Tank and Control Unit

WARNING: DO NOT locate in an area where ambient temperature exceeds 120° F (49° C). (If toilet will be mounted lower than Treatment tank contact Tech Support)

NOTE: CAUTION: Install Control Unit in a dry location.

Do not expose to rain or spray.

IMPORTANT: Install Control Unit where it will be accessible after installation.

1. Locate top of treatment tank at or below discharge of toilet and within 6 feet (1.5 m). Longer runs require longer flush time to ensure all waste clears the line.
2. Make and secure mounting frame to flat surface.
3. Secure tank to frame using 3/4" (1.9 cm) mounting straps (not included) (FIG 11).

NOTE: Placing a 3/8" (.9 cm) rubber pad under tank will help to reduce vibration and noise.

NOTE: If the Control Unit cannot be installed within 30" (76 cm), see WIRING Treatment Unit Section of these instructions.

4. Secure Control Unit within 30" (76 cm) of Treatment Tank

NOTE: Cables supplied are 16 feet (5 m)

SYSTEM STATUS PANEL - cable can be extended up to 50' (15 m)

1. Locate in head compartment where system status lights will be visible.
2. Drill 1 1/2" (38 mm) hole for back of panel
3. Route cable between panel and Control Unit.
4. Plug cable into back of panel and Control unit.
5. Mount panel using 2 screws.

LCD DISPLAY - cable can not be extended

1. Locate in an area where display can be read if necessary.
2. Secure to wall with 2 screws.
3. Route cable between display and Control Unit.

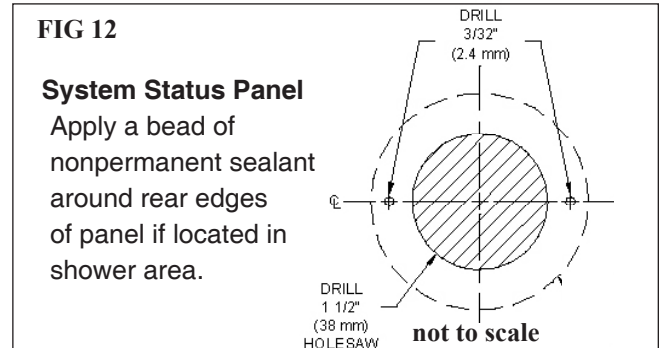
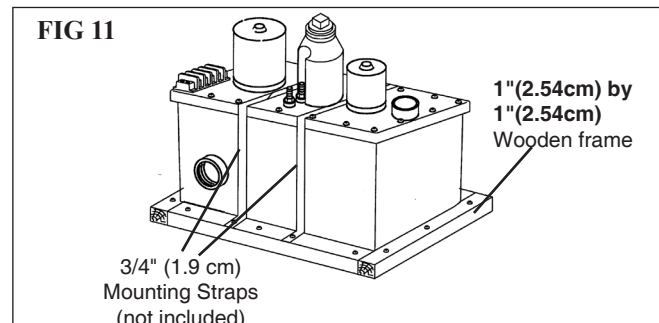
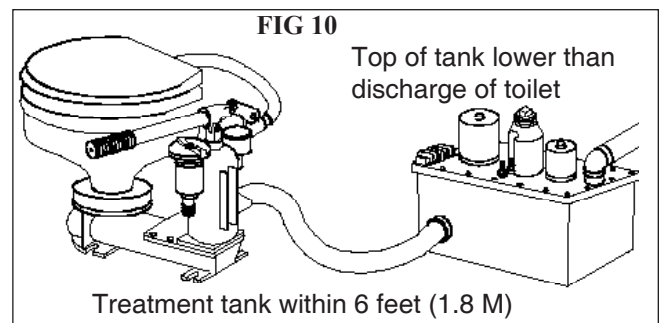

PLUMBING

WARNING: HAZARD OF FLOODING

- Installations at or below waterline, at greatest angle of heel, **MUST** have a **VENTED LOOP** installed between Treatment Tank and Seacock/Thru Hull Fitting. Install vented loops per manufacturer's instructions.
- Double clamp all below waterline hose connections.
- Do Not use metal fittings

NOTE: Use PTFE tape or non-permanent thread sealing compound on threaded PVC fittings and connections. Avoid low areas in hose that would allow untreated waste to collect.

1. Connect discharge of toilet to one inlet port.
2. Insert plug or second toilet discharge into other inlet port.
3. Determine position and glue discharge elbow to top of tank using PVC cement after cleaning with PVC cleaner.
4. Connect discharge hose from elbow to thru hull fitting.

WIRING

WARNING: HAZARD OF SHOCK AND FIRE

- Always use proper wire, wire connectors and fuse/circuit breaker. See Specification Chart.
- Secure wire properly.
- Do not connect other appliances to electro scan circuit.
- Make sure power is off before proceeding.
- Improper wiring can damage the Circuit Board and void warranty.
- Fuses must be replaced with the same type to maintain ignition protection

Treatment Unit

1. Determine proper wire size from wire chart on specifications page.
2. Run supply wire from source Positive (POS) to control unit and Negative (NEG) terminals on Treatment tank.
3. Install terminal protector on positive connection
4. Fuse or circuit breaker must be installed between source and electro scan on positive wire.

NOTE: Future access to control unit is imperative. If unit is installed in an area where access will be difficult, wiring harness can be extended to a maximum of 10 feet by increasing the black (negative) and orange (mixer) wire gauge to 10 AWG.

System Status Panel

1. Connect cable from System Status Panel to Panel 1 jack on Control Unit.
2. Install strain relief clamps along cable.
3. Follow same procedure for Panel 2 if dual installation.

Note: Normal installations have one System Status Panel. Fig 14 depicts a dual system installation.

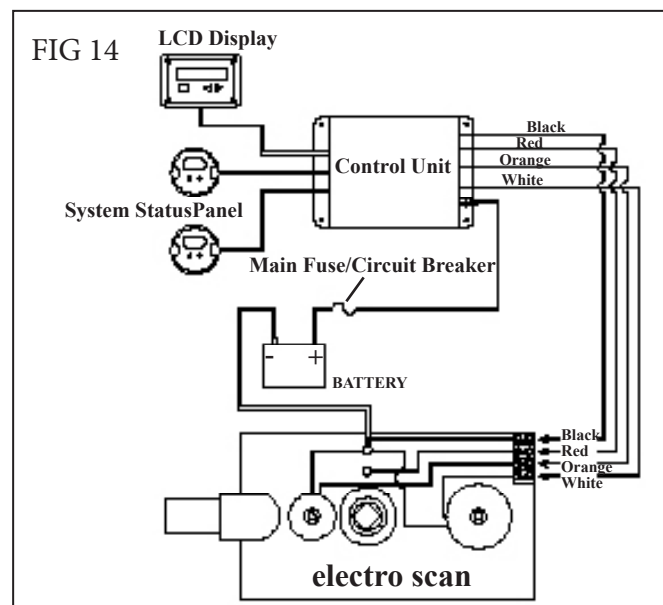
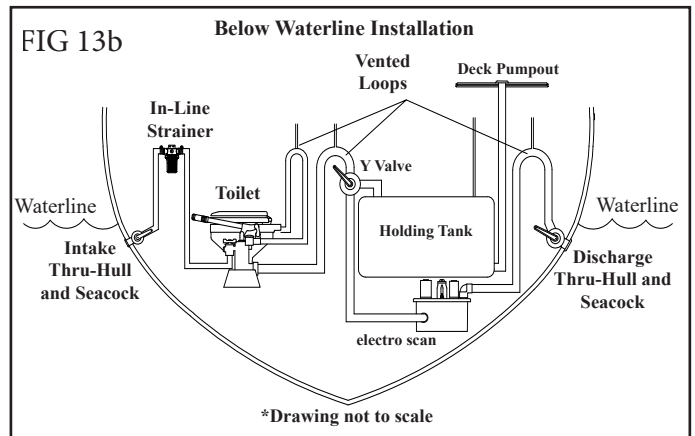
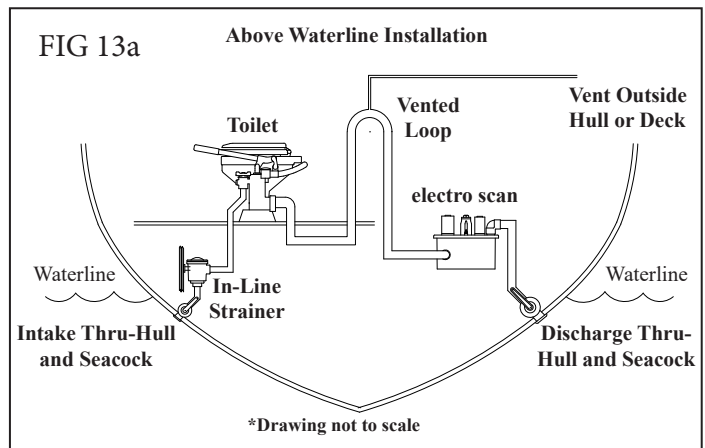
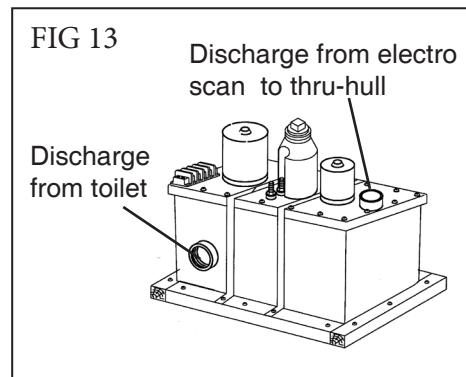

LCD Display

1. Connect cable from LCD Display to display jack on the Control Unit.
2. Install strain relief clamps along cable.

Wiring Salt Feed Pump:

Wire Salt Feed Pump as per FIG 15

Single Button operation -

Both toilet and electro scan are operated by one of the following options:

Option #1 (Recommended)

Toilet Control - Flushing toilet will also activate treatment cycle.

- For **Push Button Control** wire per FIG 16. NOTE: relay not needed when using Raritan part# 164000BR
- For **Multifunction Momentary Control** (Raritan part# 221551) wire per FIG 17.
- For **Smart Toilet Control** (Raritan part# STC) wire per FIG 18.
- For older model Atlantes contact Technical support or visit owner's manual page (discontinued product) at: www.raritaneng.com

NOTES:

- Use only a solenoid/relay with an isolated coil Raritan part number CDS* (*specify voltage)
- Do Not connect switches or any other components to the Toilet 1 or 2 outputs or the CDS.
- Determine proper wire size for toilet as per toilet instruction manual.
- When toilet push button is pressed both toilet and electro scan will activate.

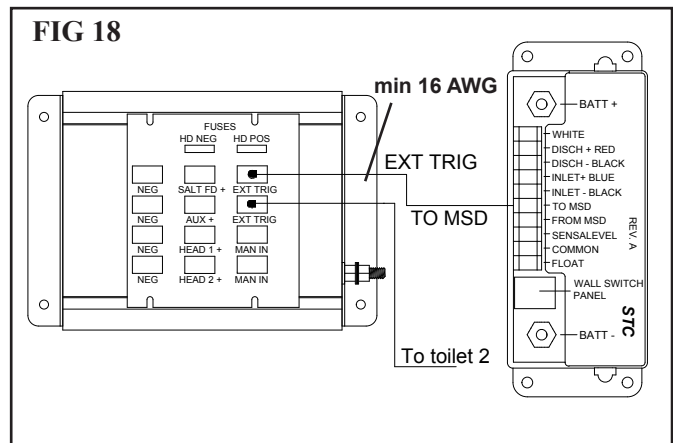
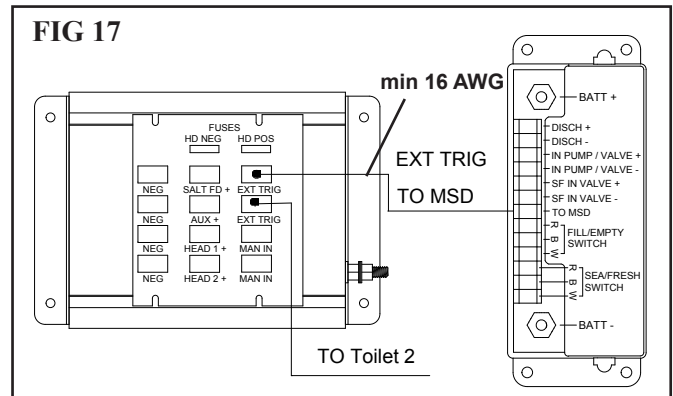
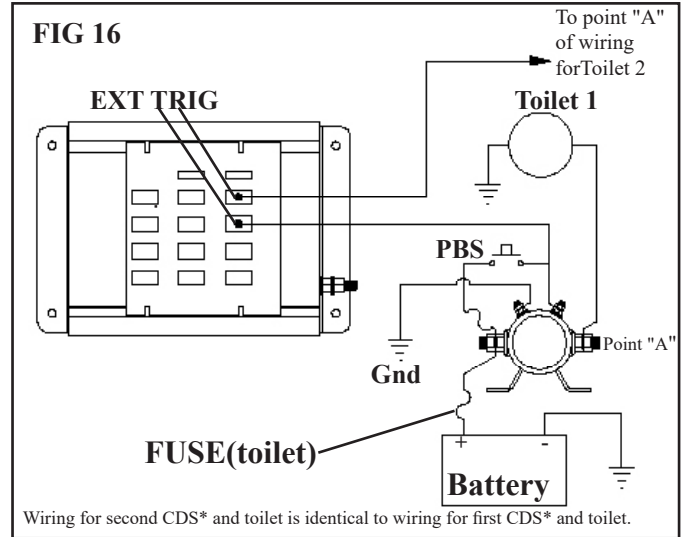
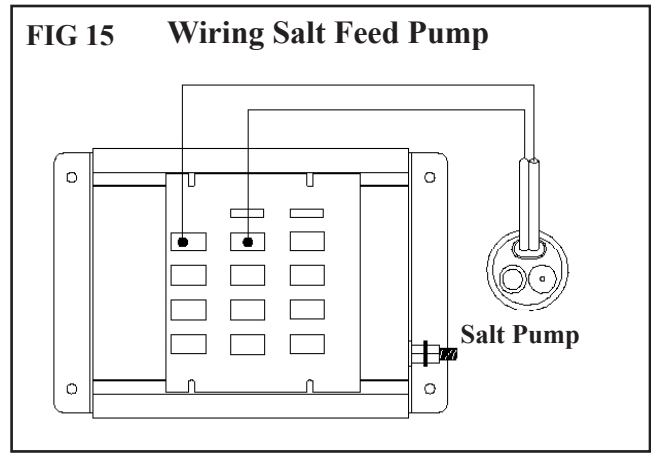

Option #2 - Activation via System Status Panel:
 "Start/Stop" button activates both the toilet and treatment cycle.

- **For other toilets** wire per FIG 19. Raritan CDS is required.
 NOTE: Toilet flush time is factory pre-set at approximately 10 seconds and is adjustable.
- **For Smart Toilet Control (Raritan part# STC)** wire per FIG 20.
 NOTE: Flush time adjustment for toilet on LCD display must be set to one second. See page 3.
- For older model Atlantes contact Technical support or visit owner's manual page (discontinued product) at:
www.raritaneng.com

NOTES:

- Use only a solenoid/relay with an isolated coil Raritan part number CDS* (*specify voltage)
- Connect only the solenoid/relay (CDS) coil to toilet 1 or 2 quick connect. **DO NOT** connect toilet negative and positive directly to outputs.
- Do Not connect switches or any other components to the Toilet 1 or 2 outputs or the CDS.
- Determine proper wire size for toilet as per toilet instruction manual.
- When Start/Stop button is pressed both toilet and electro scan will activate. Toilet flush time is controlled by control box and can be adjusted - factory preset is for 10 seconds. For STC, timing is controlled by the STC control.

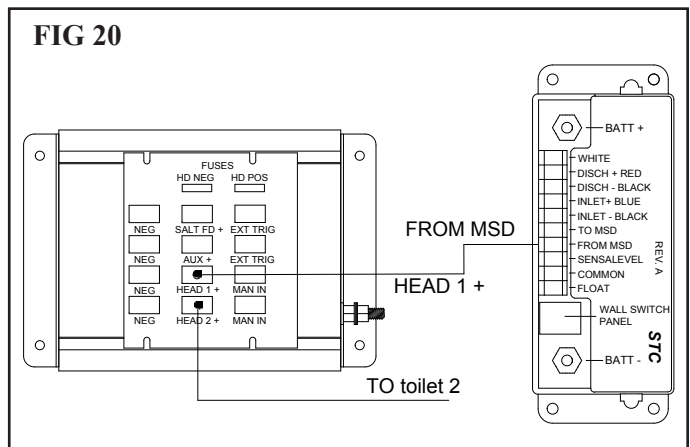
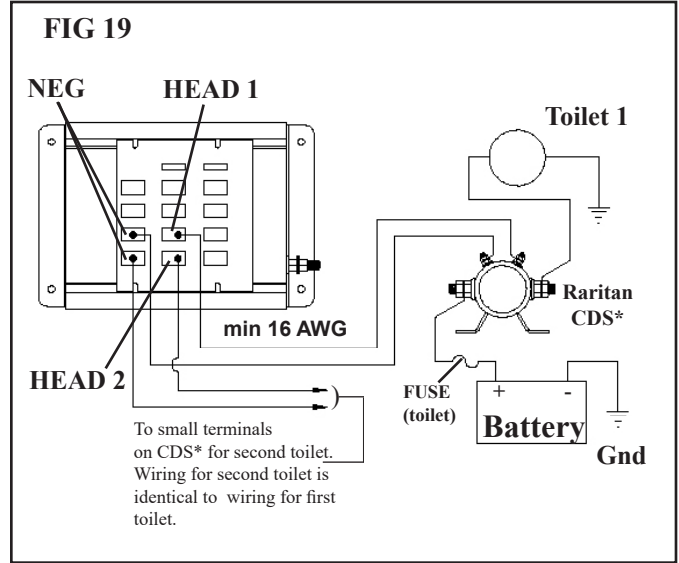

How to remove microprocessor board

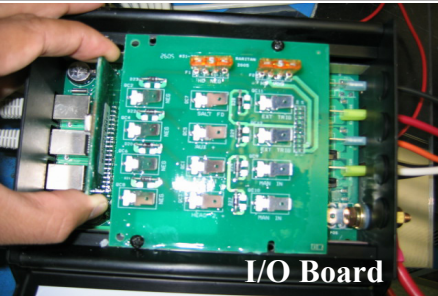

- Turn off power
- Open control unit cover
- Microprocessor board can be pulled out without disconnecting any wires
- Install replacement board
- Use anti-static bag to pack board for return to dealer/factory
- **NOTE:** Static electricity will damage the board, use precaution and proper grounding to avoid static build-up while working with the microprocessor board.

NEW INSTALLATIONS

Prior to contacting Raritan for a problem with the Electroscan please have the following information available:

- 1) Model #, Serial # and voltage of unit.**
- 2) Body of water if using raw water to flush toilet**
- 3) Warnings or errors on the display**



PROBLEM	POSSIBLE CAUSE	SOLUTION
Unit runs continuously as soon as power is turned on	<ol style="list-style-type: none"> 1. Reverse polarity , if unit is run for extended time seals on motor will damage 2. Display cable and System status cable switched, Display is blank, LED on panel flashing 3. External trigger signal is on continuously 	<ol style="list-style-type: none"> 1. Correct polarity, 2. Turn power off, switch cables to correct sockets. 3. Troubleshoot control source
Blank display	<ol style="list-style-type: none"> 1. Display was connected after power was turned on 	<ol style="list-style-type: none"> 1. Hold Mode/reset button until "Ready to Flush" is displayed
ERROR:LOW ELECTROD AMP	<ol style="list-style-type: none"> 1. Low salt causing electrode amps less than 7 amps 	<ol style="list-style-type: none"> 1a. New installation with fresh water requires some salt in the treatment tank to start salt feed system b. System requires salt source see page 2
ERROR; MIXER MOTOR OVERLD	<ol style="list-style-type: none"> 1. Incorrect wiring between control and tank 2. DISCONNECT Display Cable on Control <ol style="list-style-type: none"> a. Unit runs complete 2 minutes 30 seconds b. Unit faults in less than 15 seconds <p>DISCONNECT MIX (Orange) motor wire on control - Run a cycle</p> <ol style="list-style-type: none"> a. Unit runs complete 2 minutes 30 seconds b. Unit faults in less than 15 seconds 	<ol style="list-style-type: none"> 1. Check/Correct wiring per schematic 2. With Display Cable disconnected: <ol style="list-style-type: none"> a. Clean/Replace Display cable b. Reconnect cable go to next step <p>With MIX wire disconnected</p> <ol style="list-style-type: none"> a. Repeat to verify - If confirmed check for jam in motor b. Turn OFF Power - Inspect terminal connections on tank for looseness/corrosion, Inspect Control spade terminal, Inspect mixer fuse, fuse holder. Reseat Micro-processor (31-720) Replace control if problems persist.
ERROR: MAC MOTOR OVERLD	<ol style="list-style-type: none"> 1. Incorrect wiring between control and tank 2. DISCONNECT Display Cable on Control <ol style="list-style-type: none"> a. Unit runs complete 2 minutes 30 seconds b. Unit faults in less than 15 seconds <p>DISCONNECT MAC (White) motor wire on control - Run a cycle</p> <ol style="list-style-type: none"> a. Unit runs complete 2 minutes 30 seconds b. Unit faults in less than 15 seconds 	<ol style="list-style-type: none"> 1. Check/Correct wiring per schematic 2. With Display Cable disconnected: <ol style="list-style-type: none"> a. Clean/Replace Display cable b. Reconnect cable go to next step <p>With MAC wire disconnected</p> <ol style="list-style-type: none"> a. Repeat to verify - If confirmed check for jam in motor b. Turn OFF Power - Inspect terminal connections on tank for looseness/corrosion, Inspect Control spade terminal, Inspect macerator fuse, fuse holder. Reseat Micro-processor (31-720) Replace control if problems persist.
ERROR: ELECTRODE OVERLD	<ol style="list-style-type: none"> 1. Too much salt in the treatment tank (electrode amps higher than 28 amps) 2. Disconnect red electrode wire from black control box and run a cycle <ol style="list-style-type: none"> a. If error changes to "low electrode amp" confirms too much salt b. If error still occurs see 2b under solution 	<ol style="list-style-type: none"> 1. During new installation if too much salt gets into the system, flush toilet without running EST. Salt feed tank must be lower or same level as treatment tank to avoid siphoning of salt tank. <p>With ELECTRODE wire disconnected</p> <ol style="list-style-type: none"> a. Flush toilet several times without activating system b. Turn OFF Power - Inspect terminal connections on tank for looseness/corrosion, Inspect Control spade terminal, Inspect macerator fuse, fuse holder. Reseat Micro-processor (31-720) Replace control if problems persist.
WARNING: AMPS < 14	<ol style="list-style-type: none"> 1. Low salt in the treatment tank during treatment cycle 	<ol style="list-style-type: none"> 1a. Brackish water requires salt feed system b. Check salt feed system, check connection to salt pump, check salt pump hose.

EXISTING INSTALLATIONS

TROUBLESHOOTING

PROBLEM	POSSIBLE CAUSE	SOLUTION
"Start/Stop" doesn't activate system	<ol style="list-style-type: none"> 1. No Power 2. Open or loose connection 3. Display 4. Inoperative Start/Stop 5. Damage to cable 6. Extreme low voltage 	<ol style="list-style-type: none"> 1. Check circuit breaker or main fuse and wiring 2. Check and clean wiring connections 3. Check display for errors 4. Check, replace as necessary 5. Check replace as necessary 6. Check voltage at control unit when Start/Stop button is pressed
ERROR: Elec-rod overld	<ol style="list-style-type: none"> 1. Too much salt in the treatment tank (electrode amps higher than 28 amps) 2. Disconnect red electrode wire from black control box and run a cycle <ol style="list-style-type: none"> a. If error changes to "low electrode amp" confirms too much salt b. If error still occurs see 2b under solution 	<ol style="list-style-type: none"> 1. During new installation if too much salt gets into the system, flush toilet without running EST. Salt feed tank must be lower or same level as treatment tank to avoid siphoning of salt tank. 2. With ELECTRODE wire disconnected <ol style="list-style-type: none"> a. Flush toilet several times without activating system b. Turn OFF Power - Inspect terminal connections on tank for looseness/corrosion, Inspect Control spade terminal, Inspect macerator fuse, fuse holder. Reseat Micro-processor (31-720) Replace control if problems persist.
POS/NEG Fuse Error	<ol style="list-style-type: none"> 1. POS fuse error - Toilet switch connected directly to control 2. POS fuse blown 3. NEG fuse blown 4. NEG fuse error - Faulty relay or salt pump 	<ol style="list-style-type: none"> 1. Solenoid with isolated coil required (Raritan part CDS12 for 12V system) 2. Replace fuse 3. replace fuse 4. Check toilet relay, check salt feed pump and wiring
ERROR: MIXER MOTOR OVERLD	<ol style="list-style-type: none"> 1. Incorrect wiring between control and tank 2. DISCONNECT Display Cable on Control <ol style="list-style-type: none"> a. Unit runs complete 2 minutes 30 seconds b. Unit faults in less than 15 seconds <p>DISCONNECT MIX (Orange) motor wire on control - Run a cycle</p> <ol style="list-style-type: none"> a. Unit runs complete 2 minutes 30 seconds b. Unit faults in less than 15 seconds 	<ol style="list-style-type: none"> 1. Check/Correct wiring per schematic 2. With Display Cable disconnected: <ol style="list-style-type: none"> a. Clean/Replace Display cable b. Reconnect cable go to next step <p>With MIX wire disconnected</p> <ol style="list-style-type: none"> a. Repeat to verify - If confirmed check for jam in motor b. Turn OFF Power - Inspect terminal connections on tank for looseness/corrosion, Inspect Control spade terminal, Inspect mixer fuse, fuse holder. Reseat Micro-processor (31-720) Replace control if problems persist.
ERROR: MAC MOTOR OVERLD	<ol style="list-style-type: none"> 1. Incorrect wiring between control and tank 2. DISCONNECT Display Cable on Control <ol style="list-style-type: none"> a. Unit runs complete 2 minutes 30 seconds b. Unit faults in less than 15 seconds <p>DISCONNECT MAC (White) motor wire on control - Run a cycle</p> <ol style="list-style-type: none"> a. Unit runs complete 2 minutes 30 seconds b. Unit faults in less than 15 seconds 	<ol style="list-style-type: none"> 1. Check/Correct wiring per schematic 2. With Display Cable disconnected: <ol style="list-style-type: none"> a. Clean/Replace Display cable b. Reconnect cable go to next step <p>With MAC wire disconnected</p> <ol style="list-style-type: none"> a. Repeat to verify - If confirmed check for jam in motor b. Turn OFF Power - Inspect terminal connections on tank for looseness/corrosion, Inspect Control spade terminal, Inspect macerator fuse, fuse holder. Reseat Micro-processor (31-720) Replace control if problems persist.
Low Amp Error or Warning on Display	<ol style="list-style-type: none"> 1. Low Salt 2. Dirty Electrode Pack 3. Worn electrode 	<ol style="list-style-type: none"> 1a. Add 2 gallons of water with 8 oz.(by weight) of salt to system and run a cycle 1b. Check salt feed system if installed. 2. Clean the electrode pack following instructions in maintenance, see page 5. 3. If steps 1 or 2 do not work, replace electrode pack
Low Voltage Error or Warning	<ol style="list-style-type: none"> 1. Low Voltage 2. Drop in line voltage 3. Other Equipment on same circuit 4. Open or loose connections 	<ol style="list-style-type: none"> 1. Check battery condition, charge or replace as necessary 2. Check voltage between positive at control unit and negative at control unit or top of tank while unit is running 3. Isolate Electroscan on it's own circuit 4. Check and clean wire connections
Sewage Odor	<ol style="list-style-type: none"> 1. Odor permeating through hose or connections 2. Treatment unit leaking 3. Electrode not working properly 4. Electroscan not activated with each flush 5. Treatment unit not being stored properly 	<ol style="list-style-type: none"> 1. Rub warm, damp rag on hose. If odor transfers to rag replace hose Raritan Sanitation Hose #SFH 2. Inspect hose from toilet to tank and look for leaks on top of tank 3. Check reading on LCD display for error or warning 4. System must be activated with each flush 5. See storage under maintenance
Water around motor on or lid	Motor shaft seal leak	Order repair kit ESTRK, Includes all parts needed to repair seal leak

EXPLODED PARTS VIEW

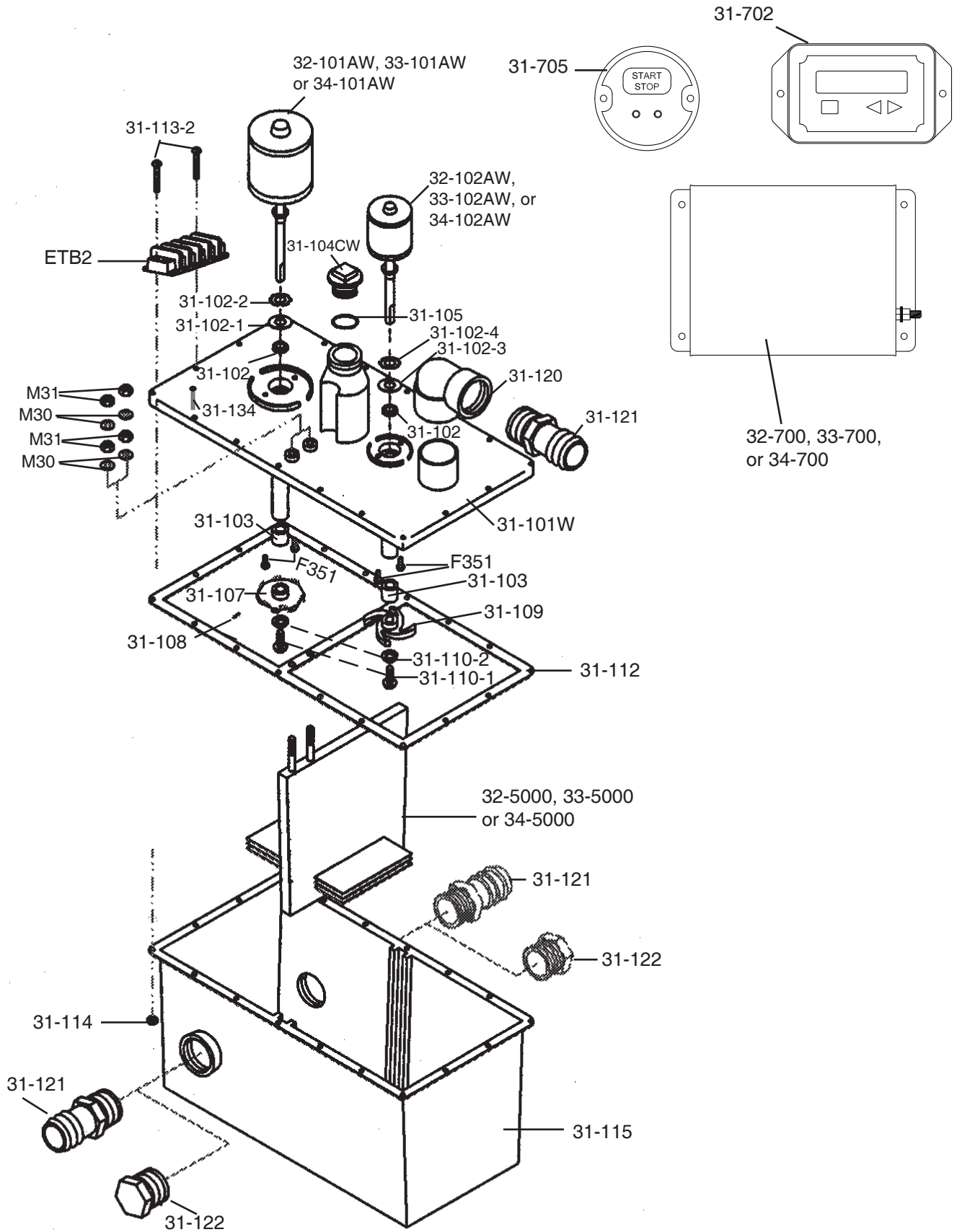

TREATMENT UNIT

Part No.	Description
32-102AW	Mixer Motor 2 1/2" Dia. 12 VDC
33-102AW	Mixer Motor 2 1/2" Dia. 24 VDC
34-102AW	Mixer Motor 2 1/2" Dia. 32 VDC
NOTE: All motors include 31-102, Seal Washer, Retaining Ring and 31-103.	
31-121	Hose Fitting (2)
31-120	Discharge Elbow 90°
M30	Electrode Nut 1/4-20 Brass (4)
M31	Electrode #14 Brass flat washer (4)
31-103	Motor Shaft Bushing (2)
31-106	10-32x7/8"RHMS,S/S (4)
31-109	Mixer Impeller
31-110-1	Impeller Bolt, 12-24x5/8", S/S (2)
31-110-2	Impeller Lock Washer, #12, S/S (2)
31-113-2	Terminal Block Bolt (2)
31-134	Cover Hold Down Screw 10-32 x 1 Hex(16)
31-114	Cover Hold Down Nut, 10-32 (18)
31-115	Treatment Tank
31-122	Intake Plug
32-5000	Electrode Pack 12 VDC
33-5000	Electrode Pack 24 VDC
34-5000	Electrode Pack 32 VDC
31-112	Cover Gasket
31-108	Macerator Set Screw, 8-32x3/16", S/S
31-107	Macerator Impeller
31-101W	Treatment Cover
31-104CW	Crossover Plug
31-105	O-Ring
31-102	Motor Shaft Seal (2)
31-102-1	Macerator Seal Washer
31-102-2	Macerator Retaining Ring
31-102-3	Mixer Seal Washer
31-102-4	Mixer Retaining Ring
32-101AW	Macerator Motor 3" Dia. 12 VDC
33-101AW	Macerator Motor 3" Dia. 24 VDC
34-101AW	Macerator Motor 3" Dia. 32 VDC
ETB2	Terminal Block
31-3001	Salt tank unit complete, two gallon (not shown)
31-3005	Four gallon salt feed tank (not shown)
32-3005	Four gallon salt feed tank w/12 volt pump (not shown)
33-3005	Four gallon salt feed tankw/24 volt pump (not shown)
32-7000	12 V DC Treatment Unit - No Control Unit, System Status Panel or LCD Display
33-7000	24 V DC Treatment Unit - No Control Unit, System Status Panel or LCD Display
34-7000	32 V DC Treatment Unit - No Control Unit, System Status Panel or LCD Display

CONTROL

Part No.	Description
31-618	Cable for LCD and System Status Panel (not shown) 16'
31-702	LCD Display
31-705	System Status Panel
32-700	Control Unit 12V
33-700	Control Unit 24V
34-700	Control Unit 32V
WAES01T	Wire Harness (not shown)

PARTS BAG (packed with each new unit)

Part No.	Description
31-111	Cable Clamp 1/2 x 1/2
31-717	Insulating Bushing (4)
ETP1	Terminal Protector Red
F110	Screw 6 x 1/2 Phil Pad HD(4) to mount Display and Start/Stop button

ESTRK (EST Repair Kit)

Part No.	Description
31-102	Motor Shaft Seal (2)
31-102-1	Macerator Seal Washer
31-102-2	Macerator Retaining Ring
31-102-3	Mixer Seal Washer
31-102-4	Mixer Retaining Ring
31-103	Motor Shaft Bushing (2)
31-105	O-Ring
F351	10-32x7/8" w/ O-ring (4)
31-112	Cover Gasket
31-113-2	Terminal Block Bolt (4)
31-114	Cover Hold Down Nut, 10-32 (4)
SL1CC	Super Lube

NOTE: We recommend 3M 4000 UV to seal the motor hold down bolts (part# F351)

() Indicates Total pieces required

OTHER INSTALLATION OPTIONS FOR THE electro-scan SYSTEM :

The electro scan has other installation options including:

1) Connection to the Sealand VacuFlush®

The above option is covered by a Technical bulletin available from Raritan by calling: 856-825-4900 or faxing in a request at: 856-825-4409 or on our website at: www.raritaneng.com. Request document # L286 v0107

®Vacuflush is a registered trademark of Sealand Technology, Inc.

LIMITED WARRANTY

Raritan Engineering Company warrants to the original purchaser that this product is free of defects in materials or workmanship for a period of one year from the product's date of purchase. Should this product prove defective by reason of improper workmanship and/or materials within the warranty period, Raritan shall, at its sole option, repair or replace the product.

1. TO OBTAIN WARRANTY SERVICE, Consumer must deliver the product prepaid, together with a detailed description of the problem, to Raritan at 530 Orange St., Millville, N.J. 08332. When requesting warranty service, purchaser must present a sales slip or other document which establishes proof of purchase. THE RETURN OF THE OWNER REGISTRATION CARD IS NOT A CONDITION PRECEDENT OF WARRANTY COVERAGE. However, please complete and return the owner Registration Card so that Raritan can contact you should a question of safety arise which could affect you.
2. THIS WARRANTY DOES NOT COVER defects caused by modifications, alterations, repairs or service of this product by anyone other than Raritan; defects in materials or workmanship supplied by others in the process of installation of this product; defects caused by installation of this product other than in accordance with the manufacturer's recommended installation instructions or standard industry procedures; physical abuse to, or misuse of, this product. This warranty also does not cover damages to equipment caused by fire, flood, external water, excessive corrosion or Act of God.
3. ANY EXPRESS WARRANTY NOT PROVIDED HEREIN, AND ANY REMEDY FOR BREACH OF CONTRACT WHICH BUT FOR THIS PROVISION MIGHT ARISE BY IMPLICATION OR OPERATION OF LAW, IS HEREBY EXCLUDED AND DISCLAIMED. ALL IMPLIED WARRANTIES SUCH AS THOSE OF MERCHANTABILITY AND OF FITNESS FOR A PARTICULAR PURPOSE, IF APPLICABLE, AS WELL AS ANY IMPLIED WARRANTIES WHICH MIGHT ARISE BY IMPLICATION OF LAW, ARE EXPRESSLY LIMITED TO A TERM OF ONE YEAR. SOME STATES DO NOT ALLOW LIMITATIONS ON HOW LONG A LIMITED WARRANTY LASTS, SO THE ABOVE LIMITATION MAY NOT APPLY TO YOU.
4. UNDER NO CIRCUMSTANCES SHALL RARITAN BE LIABLE TO PURCHASER OR ANY OTHER PERSONS FOR ANY SPECIAL OR CONSEQUENTIAL DAMAGES, WHETHER ARISING OUT OF BREACH OF WARRANTY, BREACH OF CONTRACT, OR OTHERWISE. SOME STATES DO NOT ALLOW THE EXCLUSION OR LIMITATION OF INCIDENTAL OR CONSEQUENTIAL DAMAGES, SO THE ABOVE LIMITATION OR EXCLUSION MAY NOT APPLY TO YOU.
5. No other person or entity is authorized to make any express warranty, promise or affirmation of fact or to assume any other liability on behalf of Raritan in connection with its products except as specifically set forth in this warranty.
6. This warranty gives you specific legal rights, and you may also have other rights which vary from state to state.



530 Orange Street, Millville, NJ 08332 USA
Telephone: 856-825-4900 FAX: 856-825-4409
www.raritaneng.com

Fort Lauderdale, FL
Telephone: 954-525-0378