

PLC module (2)

1. In PLC, "I" is used for input and "O" is used for output. (1 point)
 True
 False
2. Actuator is an input device that senses a physical condition. (1 point)
 True
 False
3. The LOGO!Soft user interface has the following function areas as shown in figure match them: (7 points)

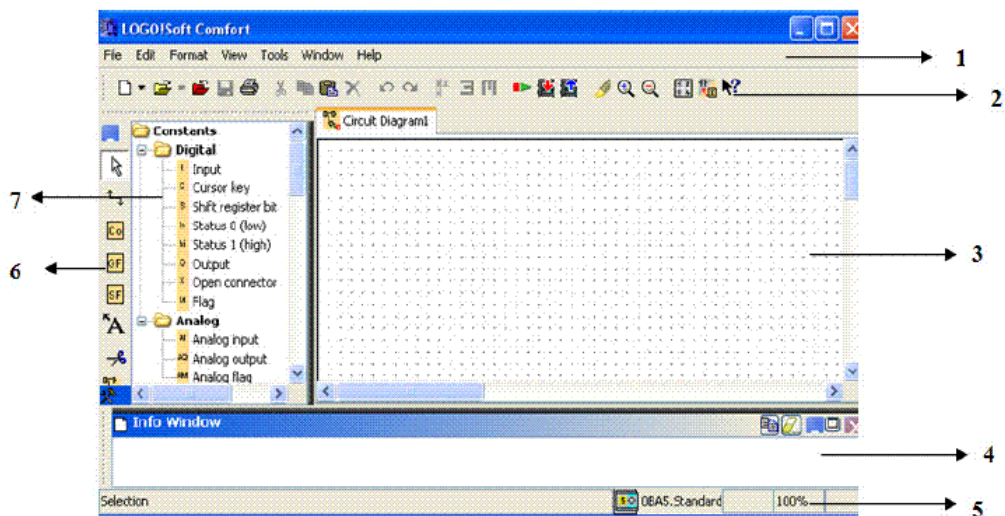

- 1. a. Toolbox
b. Info box
- 2. c. Constants, connectors, functions
d. Menu bar
- 3. e. Standard tool bar
f. Programming Interface
- 4. g. Status Bar
- 5.
- 6.
- 7.

Programmable Logic Controllers
Quiz (2) with answer key

Module 2

4. LOGO! ...R... version is equipped with relay outputs. (1 point)
- True
 - False
5. DM 8 expansion module provides : (1 point)
- 8 analog inputs and 8 analog outputs
 - 4 digital inputs and 4 digital outputs
 - 8 digital inputs and 8 digital outputs
 - 4 analog inputs and 4 analog outputs
6. One of the following is NOT PLC manufacturer: (1 point)
- Siemens
 - Mitsubishi
 - Microsoft
 - ABB
7. One of the following is an input device: (1 point)
- Motor
 - Sensor
 - Valve
 - Light
8. LOGO!24 RC operates on: (1 point)
- 24 V DC
 - 36 V DC
 - 230 V AC
 - 230 V DC
9. The part that monitors the inputs and makes decisions in PLC is: (1 point)
- CPU
 - Expansion module
 - PC interface
 - Memory

10. Solenoids, contactor coils and lamps are usually connected to: (1 point)

- Digital Outputs
- Analog Inputs
- Digital Inputs
- Analog Outputs

11. The total number of inputs for the LOGO! Basic is: (1 point)

- 24
- 16
- 8
- 4

12. which of the following is considered to be Advantage for PLC over microcontroller: (1 point)

- PLC works in severe conditions
- PLC is smaller than microcontroller
- PLC is cheaper than microcontroller
- All of them

13. An input cannot be connected to several outputs. (1 point)

- True
- False

14. PLC stores information in the form of bits (ON/OFF). (1 point)

- True
- False

15. In the Edu Trainer all the pushbuttons are normally open. (1 point)

- True
- False

16. Fiber optic barrier is used to detect metal parts only. (1 point)

- True
- False

17. The figure shown is : (1 point)



- Normally open switch
- Normally open pushbutton
- Normally closed switch
- Normally closed pushbutton

18. PLC stands for Programmable LOGO Controller. (1 point)

- True
- False

19. Soft comfort is programming software for the LOGO! (1 point)

- True
- False

20. A level transmitter that checks the level of liquid in the tank is: (1 point)

- Digital Output
- Analog Output
- Analog Input
- Digital Input

21. Match the following: (12 points)

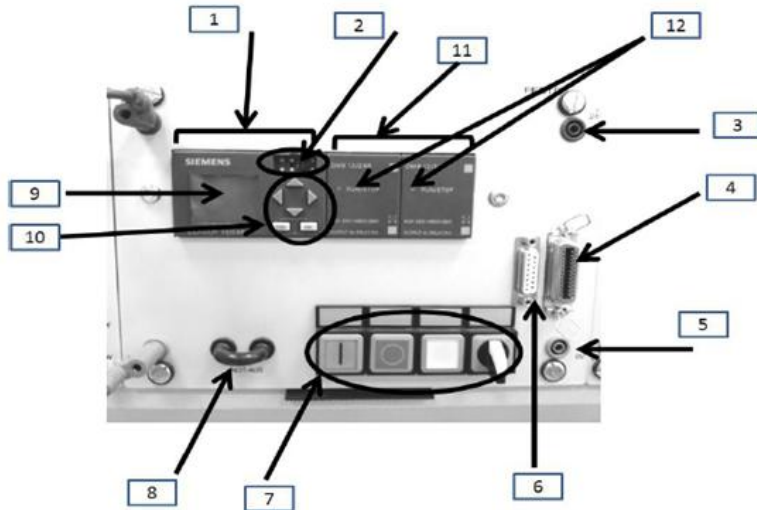

- ___ 1. a. Display unit
b. Control Unit for LOGO!
- ___ 2. c. Submin D Socket
- ___ 3. d. PC Interface
- ___ 4. e. Status display LEDs
- ___ 5. f. SysLink Interface
- ___ 6. g. Emergency-stop bridge
- ___ 7. h. Two expansion modules
- ___ 8. i. 24VDC
- ___ 9. j. 0V safety socket
- ___ 10. k. Control elements
- ___ 11. l. LOGO PLC
- ___ 12.

22. PC interface unit is used to connect PLC to computer. (1 point)

- True
- False

Programmable Logic Controllers
Quiz (2) with answer key

Module 2

23. The logic function which produces an opposite output to its input is: (1 point)

- OR function
- XOR function
- NOT function
- AND function

24. Match the following: (14 points)

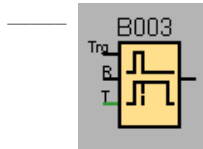

- a. OFF delay
- b. AND Block
- c. Counter
- d. Output Block
- e. OR Block
- f. Input Block
- g. Latching relay

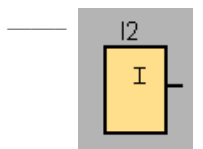
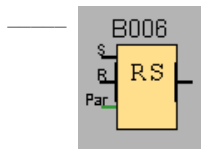
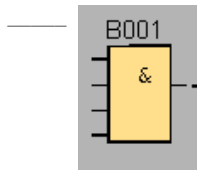
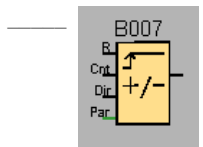
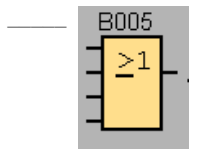
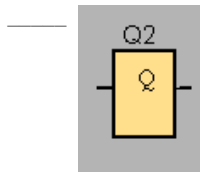

25. Match the following FBDs with their correct expressions: (16 points)

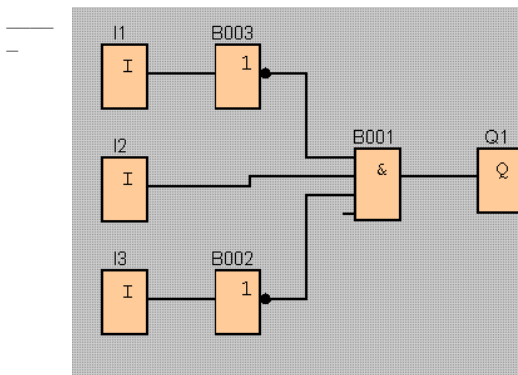
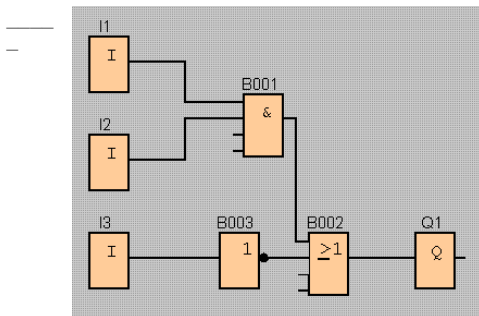
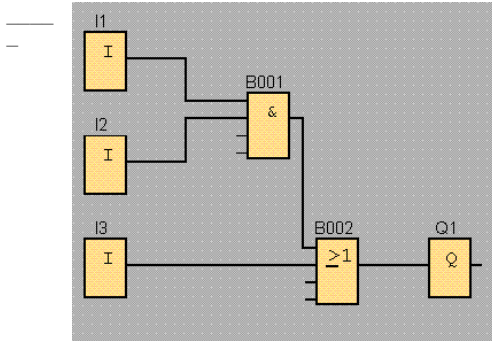

a. $Q1 = I1 \cdot I2 + I3$

b. $Q1 = \bar{I1} \cdot I2 \cdot \bar{I3}$

c. $Q1 = I1 \cdot I2 + \bar{I3}$

d. $Q1 = I1 + (I2 \cdot \bar{I3})$

e. $Q1 = (I1 + I2) \cdot (I2 + I3)$

f. $Q1 = (I1 + I2) \cdot \bar{I3}$

g. $Q1 = I1 + \bar{I2} + I3$

h. $Q1 = I1 \cdot I2 + I2 \cdot I3$

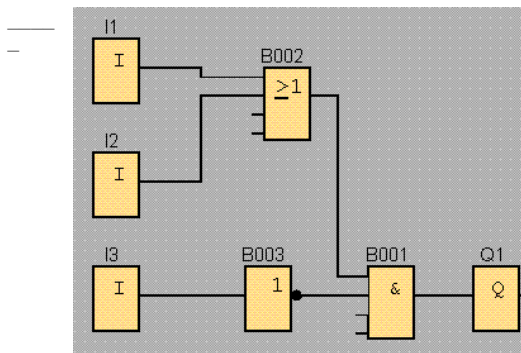
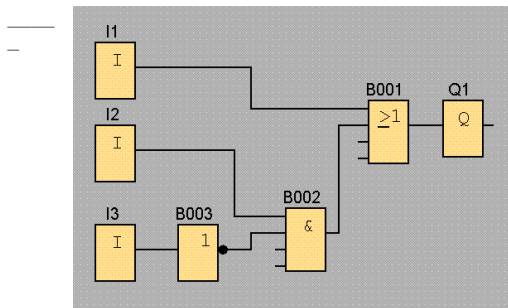
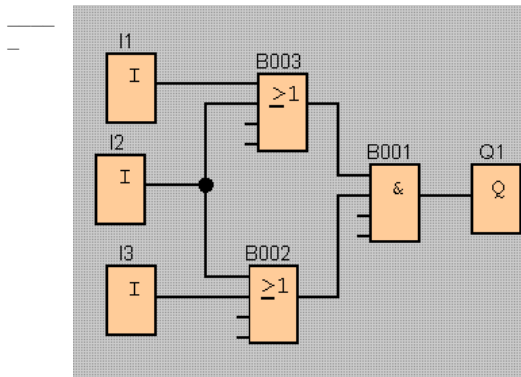
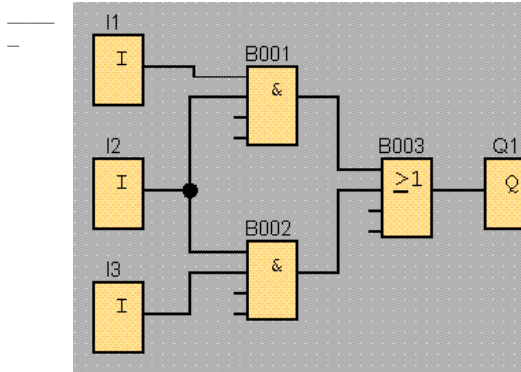

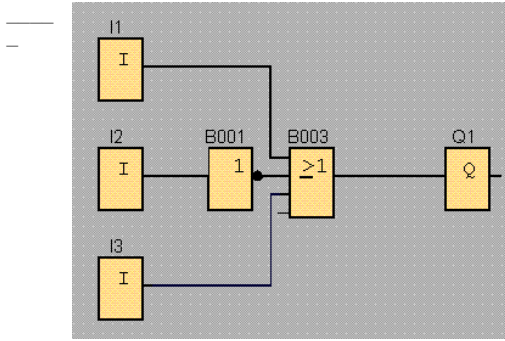

26. A PLC consists of: inputs, CPU, and outputs. (1 point)

True

False

27. The function block that is used to start an action after a certain time is (1 point)

ON Delay timer

Counter

OFF Delay timer

RS Latch

28. Gear Box is used to decrease the speed and to increase the torque. (1 point)

True

False

PLC module (2)

1. False
2. False
3. d, e, f, b, g, a, c
4. True
5. 4 digital inputs and 4 digital outputs
6. Microsoft
7. Sensor
8. 24 V DC
9. CPU
10. Digital Outputs
11. 8
12. PLC works in severe conditions
13. False
14. True
15. False
16. False
17. Normally open pushbutton
18. False
19. True
20. Analog Input
21. l, d, i, f, j, c, k, g, a, b, h, e
22. True
23. NOT function

24. a, d, e, c, b, g, f

25. a, c, b, h, e, d, f, g

26. True

27. ON Delay timer

28. True