



## High Torque, Low Speed Motors H, S, 2000, 6000, and 10,000 Series



**Interchangeable with:**

- Charlynn
- White
- Ross
- Parker
- Danfoss

Cross Reference Guide .....	2	Installation Data .....	18-19
Introduction.....	3	Shaft Seal .....	20
<b>H-Series</b> .....	4	Case Drain .....	20
Shaft Data .....	5	Shaft Rotation .....	20
Model Code.....	5	Radial Forces .....	20
Installation Data .....	5	Technical Data .....	21-23
Shaft Seal .....	6	<b>6000-Series</b> .....	24
Case Drain .....	6	Shaft Data .....	25
Shaft Rotation .....	6	Model Code.....	25
Radial Forces .....	6	Installation Data .....	26
Technical Data .....	7-9	Shaft Seal .....	26
<b>S-Series</b> .....	10	Case Drain .....	26
Shaft Data .....	11	Shaft Rotation .....	26
Model Code.....	11	Radial Forces .....	26
Installation Data .....	11	Technical Data .....	27-29
Shaft Seal .....	12	<b>10,000-Series</b> .....	30
Case Drain .....	12	Shaft Data .....	31
Shaft Rotation .....	12	Model Code.....	31
Radial Forces .....	12	Installation Data .....	32
Technical Data .....	12-15	Shaft Seal .....	33
<b>2000-Series</b> .....	16	Case Drain .....	33
Shaft Data.....	17	Shaft Rotation .....	33
Model Code.....	17	Radial Forces .....	33
		Technical Data .....	34-35

## MOTOR CROSS-REFERENCE GUIDE

Western FluidDyne	Eaton/Charlynn	White	Danfoss	Parker Ross/ TRW
H Series	A, H (130-,101-)	RS (200-)	DH, OMP	TC, TB, MK, MG
S Series	S, T (103-, 158- )	WR (255-)	OMR, DS (151-)	TB, TE, MG, MF
2000 Series	2000 (104-)	HB, RE (300-, 500-)	OMS, OME	TF, TG, MB, ME
6000 Series	4K, 6K (109-,112-)	RE, DR (500-, 600-)	OMT, TMK, TMT	TG, TH, TK, ME, MJ
10,000 Series	10K (119-)	DT	OMV, TMV	

Western FluidDyne reserves the right to make alterations to its product.

# HIGH TORQUE, LOW SPEED MOTORS

## Western FluidDyne LSHT Hydraulic Motors

Western FluidDyne’s extensive range of multiple displacement Low Speed – High Torque (LSHT) hydraulic motors are form fit and function interchangeable with many of the common motor products from Parker, White, Charlynn and Danfoss. Both Geroter and Geroler technologies are incorporated in the Western FluidDyne “H” Series, “S” series, “2000” series, “6000” series and “10,000” series.

These Western FluidDyne motors are manufactured with ISO 9001:2000 documented quality standards which results in product which consistently meets or exceeds the life and performance expectations of similar products. The Western FluidDyne product is built to perform in even the harsh environments where rugged mobile equipment is expected to operate. For optimal life the following guidelines are recommended:

- 1) Motors should be operated at less than 30% of full rated performance for the first hour of operation
- 2) During normal sustained operations, oil temperature should be between 70 to 150 degrees F (20 to 60 degrees C)
- 3) Maximum operating temperature should not exceed 190 degrees F (90 degrees C)
- 4) ISO oil cleanliness level should be 18/13 or cleaner. Normally this is achieved with Beta 10=100 full flow return line filtration.
- 5) High grade petroleum based hydraulic oil must be used
- 6) Minimum oil viscosity should be 100 SUS
- 7) Simultaneous maximum torque and maximum speed is not recommend for this design of motor

### Technical Data Summary:

Model	Distributor type	Displacement		Maximum Operating Pressure		Speed RPM
		in3/rev	cm3/rev	PSI	BAR	
H Series	Axial	3-23	50-400	2400	163	30-800
S Series	Axial	3-23	50-375	3000	200	30-970
2000 Series	Disc	5-23	80-375	3250	225	30-800
6000 Series	Disc	10-49	160-800	3400	240	30-705
10,000 Series	Disc	19-49	315- 800	4000	280	10-446

# HIGH TORQUE, LOW SPEED MOTORS

## H-SERIES

The -101 (H) Geroter™ gear set, spool valve flow distribution, hydraulic motors are a compact, highly efficient, low speed-high torque design which can be used in either parallel or series systems. These low weight advanced construction design motors are manufactured in accordance with the requirements of the ISO 9001:2000 quality system.

### Technical Specifications

FluidDyne			DISPLACEMENT cm <sup>3</sup> /r (in <sup>3</sup> /r)									
			36 cm <sup>3</sup> (2.2)	50 cm <sup>3</sup> (2.8)	80 cm <sup>3</sup> (4.9)	100 cm <sup>3</sup> (6.1)	125 cm <sup>3</sup> (7.7)	160 cm <sup>3</sup> (9.8)	200 cm <sup>3</sup> (12.2)	250 cm <sup>3</sup> (15.3)	315 cm <sup>3</sup> (19.2)	400 cm <sup>3</sup> (24.4)
Char-Lynn reference			36 cm <sup>3</sup> (2.2)	46 cm <sup>3</sup> (3.0)	74 cm <sup>3</sup> (4.5)	97 cm <sup>3</sup> (5.9)	120 cm <sup>3</sup> (7.3)	159 cm <sup>3</sup> (9.7)	185 cm <sup>3</sup> (11.3)	231 cm <sup>3</sup> (14.1)	293 cm <sup>3</sup> (17.9)	370 cm <sup>3</sup> (22.6)
MOUNTING	SHAFTS	PORTS										
2 BOLT FLANGE MOUNT	1" STRAIGHT WOODRUFF KEY	7/8" -14 O-RING	WF1011700	WF1011033	WF1011034	WF1011035	WF1011702	WF1011036	WF1011037	WF1011038	WF1011039	WF1011040
		1/2" NPTF O-RING	WF1011704	WF1011025	WF1011026	WF1011027	WF1011706	WF1011028	WF1011029	WF1011030	WF1011031	WF1011032
		MANIFOLD	WF1011708	WF1011041	WF1011042	WF1011043	WF1011710	WF1011044	WF1011045	WF1011046	WF1011047	WF1011048
	1" SAE 6B SPLINED	7/8" -14 O-RING	WF1011721	WF1011081	WF1011082	WF1011083	WF1011723	WF1011084	WF1011085	WF1011086	WF1011087	WF1011088
		1/2" NPTF O-RING	WF1011725	WF1011073	WF1011074	WF1011075	WF1011727	WF1011076	WF1011077	WF1011078	WF1011079	WF1011080
		MANIFOLD	WF1011729	WF1011089	WF1011090	WF1011091	WF1011731	WF1011092	WF1011093	WF1011094	WF1011095	WF1011098
4 BOLT FLANGE MOUNT	1" STRAIGHT WOODRUFF KEY	7/8" -14 O-RING	WF1011749	WF1011009	WF1011010	WF1011011	WF1011751	WF1011012	WF1011013	WF1011014	WF1011015	WF1011016
		1/2" NPTF O-RING	WF1011753	WF1011001	WF1011002	WF1011003	WF1011755	WF1011004	WF1011005	WF1011006	WF1011007	WF1011008
		MANIFOLD	WF1011757	WF1011017	WF1011018	WF1011019	WF1011759	WF1011020	WF1011021	WF1011022	WF1011023	WF1011024
	1" SAE 6B SPLINED	7/8" -14 O-RING	WF1011761	WF1011057	WF1011058	WF1011059	WF1011872	WF1011060	WF1011061	WF1011062	WF1011063	WF1011064
		1/2" NPTF O-RING	WF1011764	WF1011049	WF1011050	WF1011051	WF1011766	WF1011052	WF1011053	WF1011054	WF1011055	WF1011056
		MANIFOLD	WF1011768	WF1011065	WF1011066	WF1011067	WF1011770	WF1011068	WF1011069	WF1011070	WF1011071	WF1011072
Max Torque (in-lbs)	Continuous		504	717	1142	1425	1788	1806	2292	2677	3054	3850
	Intermittent		672	956	1513	1885	2372	3027	3452	4036	4470	4717
Max Pressure (PSI)	Continuous		1,840	1,813	1,813	1,813	1,813	1,813	1,596	1,596	1,596	1,451
	Intermittent		2,425	2,394	2,394	2,394	2,394	2,394	2,394	2,031	1,813	1,523
Max Flow (GPM)	Continuous		10	12	16	16	16	16	16	16	16	16
	Intermittent		12	13	20	20	20	20	20	20	20	20
Max RPM	Continuous		1050	850	650	520	390	310	260	200	156	130
	Intermittent		1270	879	740	589	475	370	296	237	189	149
Weight (LBS)			12	12	13	13	13	14	14	15	15	16

Continuous = maximum of continuous operation

Intermittent = maximum operating range for 6 seconds per minute

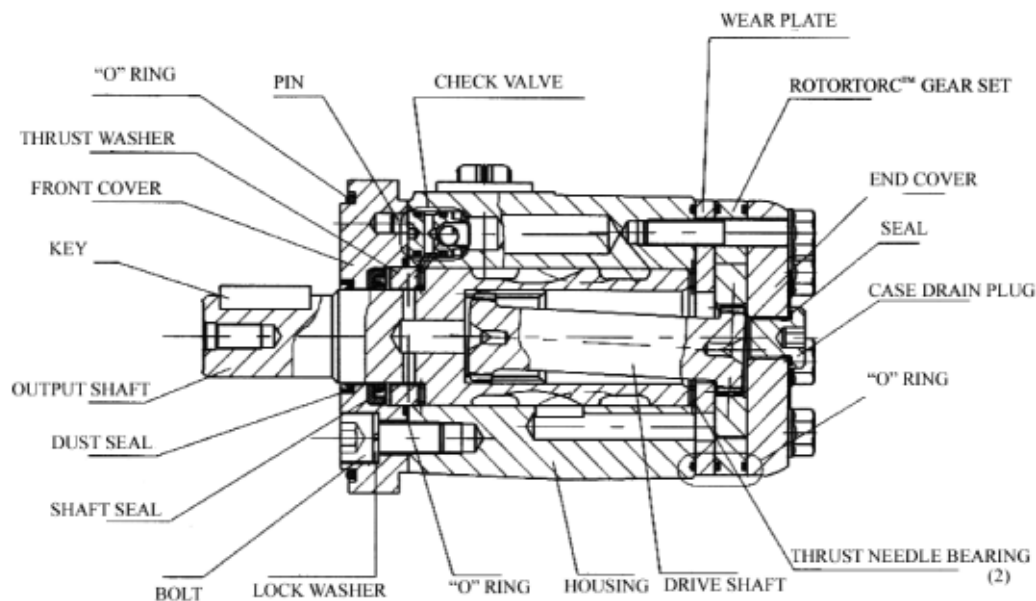

# HIGH TORQUE, LOW SPEED MOTORS

## H-SERIES SHAFT DATA

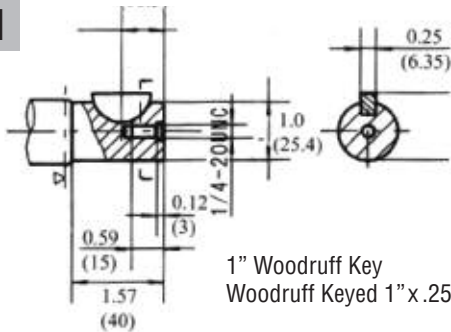
**01**

1" Woodruff Key  
Woodruff Keyed 1" x .25

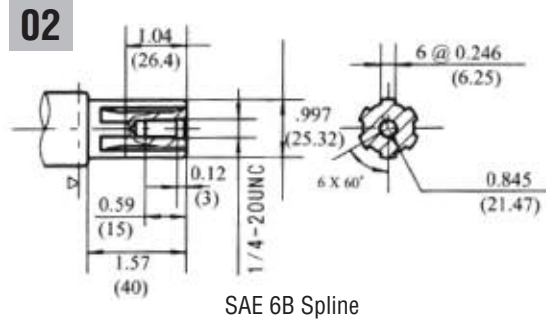
**02**

SAE 6B Spline

## H SERIES MODEL CODE (-101)

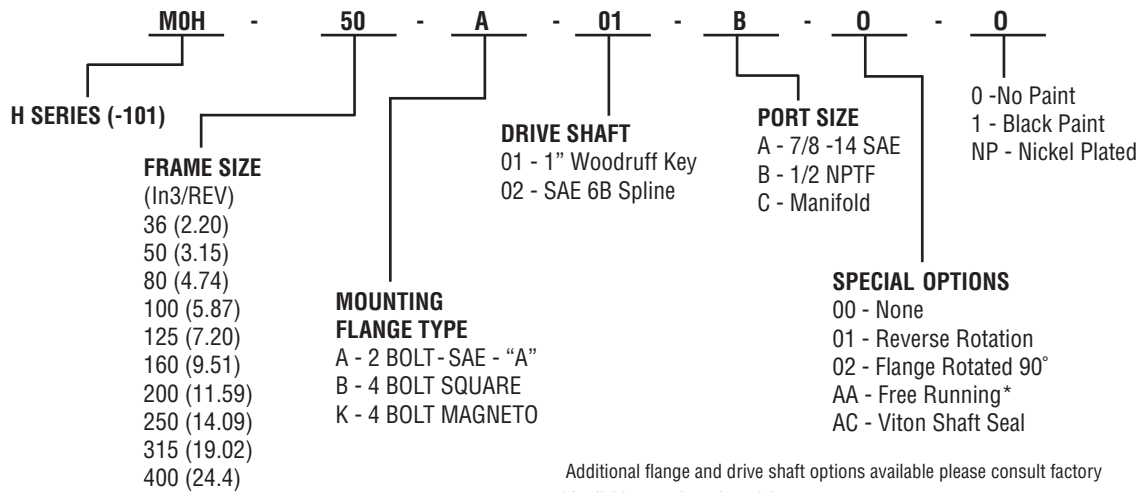

## H SERIES INSTALLATION DATA

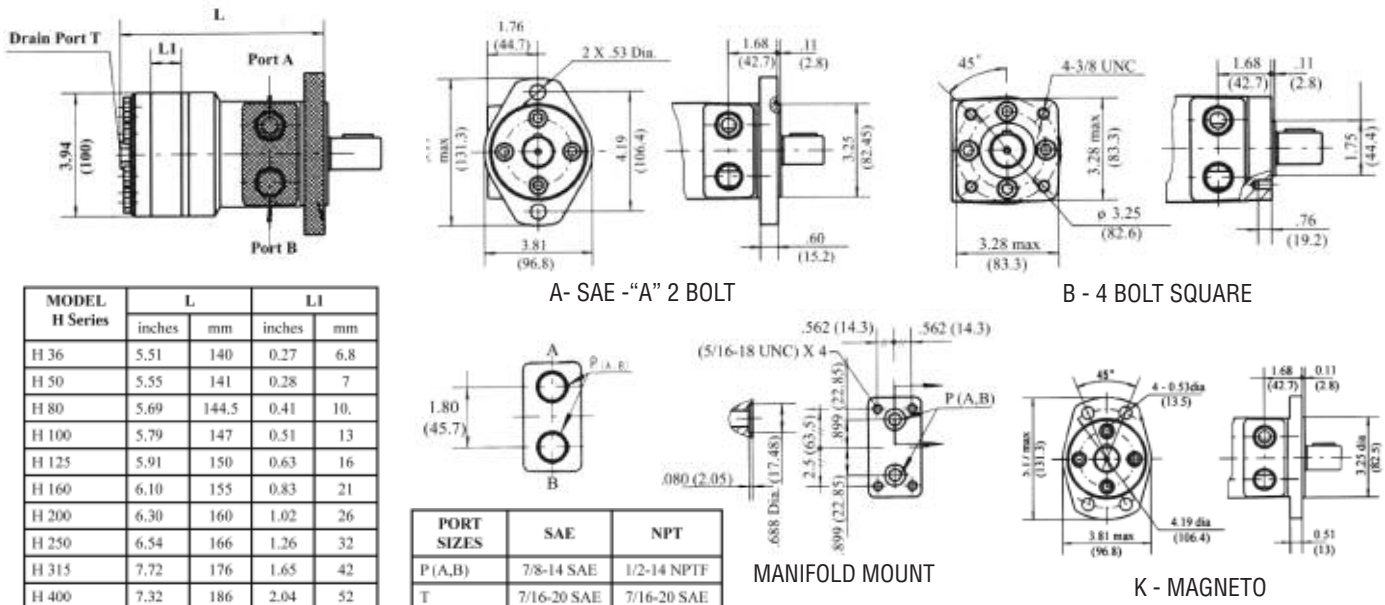

# HIGH TORQUE, LOW SPEED MOTORS

## H SERIES SHAFT SEAL RATED PRESSURE

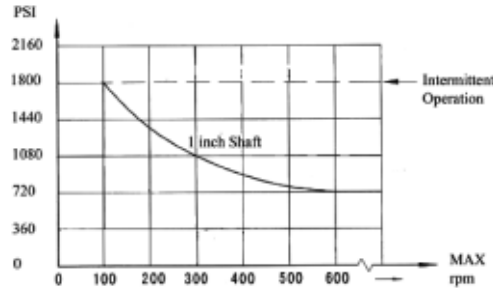
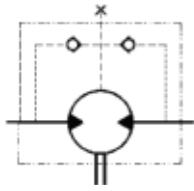

## CASE DRAIN

In applications without a motor drain line, the pressure exerted on the shaft seal is marginally in excess of the return line pressure. When the drain line is used the pressure exerted on the shaft seal is equal to the return line pressure.

## SHAFT ROTATION DIRECTION

STANDARD ROTATION VIEWED FROM SHAFT END

Port A pressurized = CW rotation  
 Port B pressurized = CCW rotation

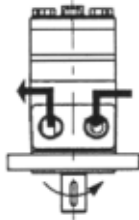

## RADIAL FORCES

Status of the shaft's radial force

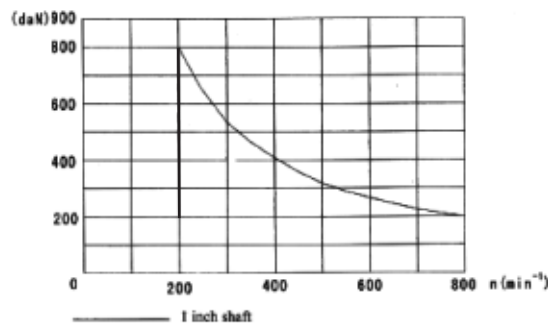

$$F_r = \frac{800 \cdot 2500}{n \cdot 95 + L} \text{ daN}$$

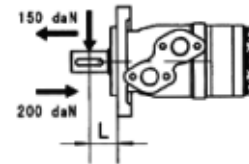

$F_r$  = Radial Force (daN)  
 $L$  = Distance (mm)  
 $n$  = Speed (rpm)  
 Round-flange  $L=30\text{mm}$   
 Square-flange  $L=24\text{mm}$

H 36 (02/022)		36 CM <sup>3</sup> /REV 2.20 IN <sup>3</sup> /REV						Max Cont.	Max Int.	
Pressure	bar (psi)	30 (440)	60 (880)	70 (1030)	80 (1175)	100 (1470)	110 (1620)	125 (1840)	165 (2429)	
FLOW	LPM (GPM)	Torque Nm (in.Lbs) Speed Specification								
	8 (2.10)	13 (115) 214 rpm	24 (212) 200 rpm	29 (256) 200 rpm	34 (300) 194 rpm	43 (380) 187 rpm	48 (424) 187 rpm	55 (486) 168 rpm	74 (654) 138 rpm	
	15 (3.95)	13 (115) 406 rpm	25 (221) 398 rpm	29 (256) 391 rpm	34 (300) 383 rpm	43 (380) 374 rpm	48 (424) 366 rpm	56 (495) 353 rpm	75 (663) 324 rpm	
	20 (5.25)	13 (115) 541 rpm	24 (212) 534 rpm	29 (256) 528 rpm	34 (300) 521 rpm	43 (380) 513 rpm	48 (424) 500 rpm	56 (495) 486 rpm	76 (672) 458 rpm	
	30 (7.90)	12 (106) 814 rpm	24 (212) 804 rpm	29 (256) 792 rpm	34 (300) 778 rpm	43 (380) 763 rpm	48 (424) 749 rpm	56 (495) 726 rpm	76 (672) 701 rpm	
	35 (9.20)	12 (106) 952 rpm	23 (203) 944 rpm	28 (247) 930 rpm	34 (300) 913 rpm	43 (380) 897 rpm	48 (424) 879 rpm	56 (495) 858 rpm	76 (672) 833 rpm	
	40 (10.50)	12 (106) 1090 rpm	23 (203) 1078 rpm	28 (247) 1064 rpm	32 (283) 1048 rpm	41 (362) 1024 rpm	47 (415) 998 rpm	55 (486) 977 rpm	75 (663) 943 rpm	
	Max Cont.	45 (11.90)	11 (97) 1232 rpm	22 (194) 1218 rpm	26 (230) 1196 rpm	32 (283) 1175 rpm	41 (362) 1149 rpm	46 (407) 1118 rpm	54 (477) 1080 rpm	
	Max Int.									

H 50 (03/028)		51.7 CM <sup>3</sup> /REV 3.15 IN <sup>3</sup> /REV						Max Cont.	Max Int.	
Pressure	bar (psi)	30 (440)	60 (880)	70 (1030)	80 (1175)	100 (1470)	110 (1620)	125 (1840)	165 (2429)	
FLOW	LPM (GPM)	Torque Nm (in.Lbs) Speed Specification								
	8 (2.10)	17 (150) 154 rpm	38 (336) 149 rpm	44 (390) 144 rpm	50 (443) 141 rpm	63 (558) 135 rpm	70 (620) 129 rpm	79 (700) 123 rpm	104 (920) 92 rpm	
	15 (3.95)	19 (168) 292 rpm	38 (336) 286 rpm	44 (389) 238 rpm	50 (443) 277 rpm	64 (566) 273 rpm	71 (628) 267 rpm	80 (708) 262 rpm	105 (930) 231 rpm	
	20 (5.25)	17 (150) 390 rpm	38 (336) 385 rpm	44 (389) 328 rpm	51 (451) 326 rpm	64 (566) 374 rpm	71 (628) 367 rpm	80 (708) 360 rpm	107 (947) 332 rpm	
	30 (7.90)	16 (142) 586 rpm	37 (328) 579 rpm	44 (389) 572 rpm	50 (443) 568 rpm	64 (566) 562 rpm	71 (628) 556 rpm	80 (708) 546 rpm	108 (956) 516 rpm	
	35 (9.20)	15 (134) 683 rpm	36 (320) 675 rpm	43 (320) 670 rpm	50 (443) 663 rpm	63 (558) 656 rpm	71 (628) 647 rpm	80 (708) 641 rpm	107 (947) 614 rpm	
	45 (11.90)	14 (126) 879 rpm	34 (304) 868 rpm	42 (374) 862 rpm	49 (435) 855 rpm	63 (558) 849 rpm	70 (620) 840 rpm	80 (708) 833 rpm	107 (947) 799 rpm	
	Max Cont.	50 (13.20)	13 (118) 975 rpm	33 (296) 962 rpm	41 (368) 955 rpm	48 (427) 949 rpm	62 (550) 943 rpm	68 (605) 937 rpm	79 (700) 927 rpm	
	Max Int.									

# HIGH TORQUE, LOW SPEED MOTORS

1-800-842-5377

## H SERIES TECHNICAL DATA

H 80 (05/045)		77.7 CM <sup>3</sup> /REV 4.74 IN <sup>3</sup> /REV						Max Cont.	Max Int.
Pressure	bar (psi)	30 (440)	60 (880)	70 (1030)	80 (1175)	100 (1470)	110 (1620)	125 (1840)	165 (2429)
F L O W	LPM (GPM)	Torque Nm (in.Lbs) Speed Specification							
	8 (2.10)	29 (256)	60 (531)	70 (620)	80 (708)	101 (894)	111 (982)	128 (1133)	168 (1487)
		97 rpm	94 rpm	91 rpm	88 rpm	84 rpm	79 rpm	74 rpm	50 rpm
	15 (3.95)	29 (256)	61 (539)	71 (628)	81 (717)	101 (894)	114 (1009)	129 (1142)	170 (1505)
		184 rpm	181 rpm	178 rpm	175 rpm	171 rpm	167 rpm	162 rpm	140 rpm
	20 (5.25)	28 (248)	60 (531)	71 (628)	81 (717)	101 (894)	112 (991)	129 (1142)	170 (1505)
		247 rpm	243 rpm	241 rpm	238 rpm	235 rpm	231 rpm	225 rpm	205 rpm
	30 (7.90)	25 (221)	58 (513)	69 (610)	79 (699)	100 (855)	111 (982)	128 (1133)	171 (1513)
		370 rpm	366 rpm	363 rpm	360 rpm	356 rpm	351 rpm	346 rpm	323 rpm
	35 (9.20)	24 (212)	57 (504)	68 (602)	78 (690)	99 (876)	110 (974)	126 (1115)	171 (1513)
		432 rpm	427 rpm	424 rpm	421 rpm	416 rpm	412 rpm	407 rpm	387 rpm
	45 (11.90)	22 (195)	54 (478)	66 (584)	77 (681)	97 (858)	109 (965)	124 (1097)	169 (1496)
		555 rpm	550 rpm	546 rpm	542 rpm	538 rpm	532 rpm	528 rpm	503 rpm
	50 (13.20)	20 (177)	53 (469)	54 (566)	75 (664)	96 (850)	107 (947)	123 (1089)	168 (1487)
	616 rpm	609 rpm	606 rpm	603 rpm	599 rpm	594 rpm	588 rpm	561 rpm	
Max Cont.	60 (15.85)	19 (168)	52 (460)	63 (558)	74 (655)	95 (841)	107 (947)	123 (1089)	168 (1487)
		740 rpm	732 rpm	727 rpm	723 rpm	718 rpm	713 rpm	707 rpm	675 rpm
Max Int.	75 (19.75)	16 (142)	47 (416)	59 (522)	72 (637)	91 (805)	105 (929)	121 (1071)	
		827 rpm	820 rpm	817 rpm	813 rpm	808 rpm	804 rpm	796 rpm	

H 100 (06/059)		96.2 CM <sup>3</sup> /REV 5.87 IN <sup>3</sup> /REV						Max Cont.	Max Int.
Pressure	bar (psi)	30 (440)	60 (880)	70 (1030)	80 (1175)	100 (1470)	110 (1620)	125 (1840)	165 (2429)
F L O W	LPM (GPM)	Torque Nm (in.Lbs) Speed Specification							
	8 (2.10)	36 (319)	75 (664)	88 (779)	101 (984)	126 (1115)	141 (1248)	160 (1460)	210 (1859)
		78 rpm	75 rpm	73 rpm	70 rpm	67 rpm	63 rpm	56 rpm	34 rpm
	15 (3.95)	35 (310)	75 (664)	89 (788)	101 (894)	128 (1133)	141 (1248)	160 (1416)	213 (1885)
		149 rpm	145 rpm	143 rpm	141 rpm	137 rpm	134 rpm	129 rpm	109 rpm
	20 (5.25)	33 (292)	74 (665)	88 (779)	101 (984)	126 (1115)	140 (1239)	161 (1451)	212 (1876)
		199 rpm	196 rpm	195 rpm	191 rpm	189 rpm	185 rpm	179 rpm	161 rpm
	30 (7.90)	31 (274)	72 (637)	85 (752)	98 (867)	123 (1089)	137 (1212)	157 (1389)	213 (1885)
		299 rpm	296 rpm	293 rpm	291 rpm	288 rpm	284 rpm	280 rpm	259 rpm
	35 (9.20)	29 (257)	69 (611)	83 (735)	96 (850)	121 (1070)	135 (1195)	155 (1372)	212 (1876)
		349 rpm	345 rpm	344 rpm	341 rpm	337 rpm	335 rpm	330 rpm	310 rpm
	45 (11.90)	28 (248)	66 (584)	81 (717)	94 (832)	119 (1053)	133 (1177)	153 (1354)	208 (1841)
		449 rpm	445 rpm	442 rpm	439 rpm	435 rpm	432 rpm	428 rpm	405 rpm
	50 (13.20)	24 (217)	65 (575)	78 (690)	93 (823)	117 (1035)	132 (1168)	152 (1345)	207 (1832)
	498 rpm	493 rpm	491 rpm	490 rpm	486 rpm	481 rpm	477 rpm	457 rpm	
Max Cont.	60 (15.85)	23 (204)	63 (558)	77 (681)	92 (814)	116 (1027)	131 (1159)	151 (1336)	207 (1832)
		598 rpm	593 rpm	589 rpm	587 rpm	583 rpm	578 rpm	573 rpm	549 rpm
Max Int.	75 (19.75)	20 (117)	57 (504)	74 (655)	88 (779)	113 (1000)	129 (1142)	150 (1328)	
		673 rpm	667 rpm	664 rpm	661 rpm	657 rpm	654 rpm	648 rpm	

H 125 (07/073)		117.9 CM <sup>3</sup> /REV 7.20 IN <sup>3</sup> /REV						Max Cont.	Max Int.
Pressure	bar (psi)	30 (440)	60 (880)	70 (1030)	80 (1175)	100 (1470)	110 (1620)	125 (1840)	165 (2429)
F L O W	LPM (GPM)	Torque Nm (in.Lbs) Speed Specification							
	8 (2.10)	45 (398)	94 (832)	111 (982)	127 (1124)	158 (1398)	176 (1558)	201 (1719)	263 (2328)
		62 rpm	60 rpm	59 rpm	56 rpm	54 rpm	50 rpm	46 rpm	26 rpm
	15 (3.95)	44 (389)	94 (832)	111 (982)	127 (1124)	160 (1416)	177 (1566)	202 (1788)	267 (2363)
		118 rpm	115 rpm	114 rpm	113 rpm	110 rpm	108 rpm	105 rpm	86 rpm
	20 (5.25)	42 (372)	93 (823)	110 (974)	127 (1124)	159 (1407)	176 (1558)	202 (1788)	268 (2372)
		158 rpm	156 rpm	155 rpm	152 rpm	150 rpm	148 rpm	144 rpm	129 rpm
	30 (7.90)	40 (354)	91 (805)	108 (956)	124 (1097)	156 (1381)	174 (1540)	198 (1752)	268 (378)
		238 rpm	235 rpm	233 rpm	231 rpm	229 rpm	225 rpm	222 rpm	205 rpm
	35 (9.20)	38 (356)	89 (788)	106 (938)	122 (1080)	154 (1363)	172 (1522)	196 (1735)	267 (2363)
		227 rpm	274 rpm	273 rpm	272 rpm	268 rpm	266 rpm	263 rpm	247 rpm
	45 (11.90)	37 (327)	85 (752)	103 (912)	120 (1062)	151 (1336)	170 (1505)	194 (1717)	263 (2328)
		356 rpm	353 rpm	352 rpm	349 rpm	347 rpm	343 rpm	341 rpm	321 rpm
	50 (13.20)	33 (292)	84 (743)	100 (885)	118 (1044)	149 (1319)	167 (1478)	192 (1699)	260 (2301)
	396 rpm	392 rpm	390 rpm	390 rpm	387 rpm	383 rpm	380 rpm	363 rpm	
Max Cont.	60 (15.85)	32 (283)	81 (717)	99 (876)	116 (1027)	147 (1301)	166 (1469)	191 (1690)	259 (2292)
		421 rpm	471 rpm	469 rpm	467 rpm	465 rpm	461 rpm	457 rpm	436 rpm
Max Int.	75 (20.8)	26 (230)	75 (664)	93 (823)	110 (974)	142 (1257)	159 (1407)	185 (1837)	
		594 rpm	588 rpm	587 rpm	581 rpm	576 rpm	584 rpm	579 rpm	

## H SERIES TECHNICAL DATA

H 160 (10/097)		156 CM <sup>3</sup> /REV 9.51 IN <sup>3</sup> /REV					Max Cont.	Max Int.	
Pressure	bar (psi)	30 (440)	60 (880)	70 (1030)	80 (1175)	100 (1470)	110 (1620)	125 (1840)	165 (2429)
F L O W	LPM (GPM)	Torque Nm (in.Lbs) Speed Specification							
	8 (2.10)	57 (505)	121(1070)	142 (1260)	162 (1435)	202 (1790)	225 (1990)	243 (2150)	334 (2955)
		48 rpm	47 rpm	46 rpm	44 rpm	42 rpm	40 rpm	39 rpm	24 rpm
	15 (3.95)	56 (496)	121 (1071)	142 (1260)	162 (1435)	204 (1805)	227 (2010)	245 (2170)	341 (3020)
		93 rpm	90 rpm	90 rpm	89 rpm	88 rpm	86 rpm	86 rpm	75 rpm
	20 (5.25)	55 (487)	120 (1060)	140 (1240)	162 (1435)	203 (1795)	226 (2000)	244 (2160)	342 (3025)
		123 rpm	122 rpm	121 rpm	119 rpm	117 rpm	116 rpm	116 rpm	104 rpm
	30 (7.90)	54 (478)	117 (1035)	139 (1230)	160 (1415)	201 (1780)	224 (1980)	242 (2140)	340 (3010)
		185 rpm	183 rpm	182 rpm	180 rpm	178 rpm	176 rpm	175 rpm	163 rpm
	35 (9.20)	52 (460)	115 (1020)	137 (1215)	159 (1410)	199 (1760)	220 (1950)	242 (2140)	337 (2980)
		215 rpm	213 rpm	213 rpm	211 rpm	210 rpm	208 rpm	207 rpm	196 rpm
	45 (11.90)	50 (442)	112 (995)	134 (1185)	156 (1380)	196 (1735)	220 (1950)	238 (2105)	335 (2965)
		277 rpm	275 rpm	275 rpm	273 rpm	271 rpm	169 rpm	268 rpm	256 rpm
	50 (13.20)	45 (398)	110 (975)	132 (1170)	153 (1355)	194 (1720)	216 (1975)	233 (1975)	330 (2920)
	308 rpm	307 rpm	305 rpm	303 rpm	302 rpm	299 rpm	299 rpm	287 rpm	
Max Cont.	60 (15.85)	44 (390)	106 (940)	130 (1150)	151 (1340)	192 (1670)	214 (1895)	231 (2045)	328 (2905)
		370 rpm	368 rpm	368 rpm	364 rpm	362 rpm	360 rpm	359 rpm	347 rpm
Max Int.	75 (19.75)	32 (283)	96 (850)	119 (1055)	142 (1260)	182 (1610)	205 (1815)	222 (19650)	
		458 rpm	463 rpm	457 rpm	456 rpm	453 rpm	451 rpm	451 rpm	

H 200 (11/113)		190 CM <sup>3</sup> /REV 11.50 IN <sup>3</sup> /REV					Max Cont.	Max Int.	
Pressure	bar (psi)	30 (440)	60 (880)	70 (1030)	80 (1175)	100 (1470)	110 (1620)	150 (2208)	
F L O W	LPM (GPM)	Torque Mn (in.Lbs) Speed Specification							
	8 (2.10)	73 (646)	153 (1354)	179 (1584)	204 (1805)	256 (2266)	283 (2505)	385 (3407)	
		39 rpm	37 rpm	36 rpm	35 rpm	32 rpm	28 rpm	12 rpm	
	15 (3.95)	73 (646)	152 (1345)	180 (1593)	205 (1814)	259 (2292)	266 (2354)	390 (3407)	
		74 rpm	72 rpm	71 rpm	71 rpm	70 rpm	68 rpm	58 rpm	
	20 (5.25)	71 (628)	151 (1336)	178 (1575)	204 (1805)	256 (2266)	285 (2522)	390 (3452)	
		99 rpm	98 rpm	97 rpm	95 rpm	94 rpm	91 rpm	81 rpm	
	30 (7.90)	68 (602)	149 (1319)	175 (1549)	202 (1788)	254 (2248)	283 (2505)	388 (3434)	
		148 rpm	147 rpm	146 rpm	144 rpm	142 rpm	139 rpm	128 rpm	
	35 (9.20)	65 (575)	146 (1292)	173 (1531)	200 (1770)	252 (2230)	281 (2487)	386 (3416)	
		173 rpm	172 rpm	171 rpm	169 rpm	168 rpm	165 rpm	155 rpm	
	45 (11.9)	63 (558)	142 (1237)	170 (1505)	196 (1735)	247 (2186)	277 (2451)	382 (3380)	
		222 rpm	221 rpm	220 rpm	218 rpm	216 rpm	214 rpm	203 rpm	
	50 (13.2)	58 (513)	138 (1221)	166 (1469)	193 (1708)	244 (2159)	272 (2407)	378 (3345)	
	247 rpm	245 rpm	244 rpm	244 rpm	242 rpm	239 rpm	229 rpm		
Max Cont.	60 (15.85)	56 (496)	136 (1204)	163 (1443)	191 (1690)	241 (2133)	269 (2381)	375 (3319)	
		296 rpm	294 rpm	293 rpm	292 rpm	290 rpm	287 rpm	277 rpm	
Max Int.	75 (19.75)	42 (372)	121 (1070)	150 (1328)	177 (1566)	226 (2000)			
		370 rpm	367 rpm	367 rpm	365 rpm	364 rpm			

H 250 (14/141)		231 CM <sup>3</sup> /REV 14.09 IN <sup>3</sup> /REV					Max Cont.	Max Int.	
Pressure	bar (psi)	30 (440)	60 (880)	70 (1030)	80 (1175)	100 (1470)	110 (1620)	140 (2060)	
F L O W	LPM (GPM)	Torque Nm (in.Lbs) Speed Specification							
	8 (2.10)	93 (823)	195 (1726)	226 (2000)	259 (2292)	325 (2876)	357 (3159)		
		31 rpm	29 rpm	29 rpm	27 rpm	25 rpm	24 rpm		
	15 (3.95)	92 (814)	192 (1699)	226 (2000)	260 (2301)	325 (2876)	360 (3186)	456 (4036)	
		60 rpm	58 rpm	57 rpm	57 rpm	55 rpm	55 rpm	46 rpm	
	20 (5.25)	90 (797)	191 (1690)	225 (1991)	258 (2283)	322 (2850)	356 (3151)	455 (4027)	
		79 rpm	78 rpm	77 rpm	76 rpm	75 rpm	75 rpm	65 rpm	
	30 (7.90)	86 (761)	188 (1664)	221 (1956)	255 (2257)	319 (2823)	354 (3153)	452 (4000)	
		119 rpm	118 rpm	117 rpm	116 rpm	114 rpm	114 rpm	103 rpm	
	35 (9.20)	82 (726)	184 (1628)	217 (1920)	251 (2221)	317 (2805)	350 (3098)	448 (3965)	
		138 rpm	137 rpm	135 rpm	133 rpm	133 rpm	124 rpm	124 rpm	
	45 (11.9)	79 (699)	179 (1584)	214 (1894)	246 (2177)	312 (2761)	345 (3053)	442 (3912)	
		179 rpm	178 rpm	177 rpm	176 rpm	173 rpm	173 rpm	163 rpm	
	50 (13.2)	74 (655)	174 (1540)	209 (1850)	243 (2151)	306 (2708)	339 (3000)	438 (3876)	
	198 rpm	197 rpm	197 rpm	195 rpm	194 rpm	193 rpm	185 rpm		
Max Cont.	60 (15.85)	71 (628)	171 (1513)	206 (1823)	239 (2115)	303 (2682)	336 (2974)	433 (3832)	
		237 rpm	236 rpm	236 rpm	234 rpm	232 rpm	232 rpm	224 rpm	
Max Int.	75 (19.75)	53 (469)	153 (1353)	189 (1673)	221 (1956)	280 (2478)	312 (2761)		
		297 rpm	295 rpm	295 rpm	293 rpm	292 rpm	291 rpm		



# HIGH TORQUE, LOW SPEED MOTORS

## H SERIES TECHNICAL DATA

H 315 (18/179)		312 CM <sup>3</sup> /REV 19.03 IN <sup>3</sup> /REV				Max Cont.	Max Int.
Pressure	bar (psi)	30 (440)	60 (880)	70 (1030)	80 (1175)	100 (1470)	125 (1840)
F L O W	LPM (GPM)	Torque Nm (in.Lbs) Speed Specification					
	8 (2.10)	116 (1027)	243 (2151)	282 (2496)	313 (2770)	388 (3434)	
		25 rpm	24 rpm	22 rpm	16 rpm	13 rpm	
	15 (3.95)	115 (1018)	243 (2151)	284 (2513)	324 (2867)	406 (3593)	503 (4452)
		47 rpm	46 rpm	45 rpm	43 rpm	41 rpm	20 rpm
	20 (5.25)	114 (1009)	242 (2142)	282 (2496)	323 (2859)	405 (3584)	505 (4469)
		63 rpm	62 rpm	61 rpm	58 rpm	56 rpm	44 rpm
	30 (7.90)	109 (956)	237 (2097)	277 (2451)	319 (2823)	401 (3549)	501 (4433)
		94 rpm	93 rpm	92 rpm	90 rpm	88 rpm	77 rpm
	35 (9.20)	105 (929)	232 (2053)	273 (2416)	314 (2779)	397 (3513)	497 (4398)
		110 rpm	109 rpm	108 rpm	106 rpm	103 rpm	93 rpm
	45 (11.9)	99 (876)	226 (2000)	268 (2372)	309 (2735)	391 (3460)	491 (4345)
		141 rpm	141 rpm	139 rpm	137 rpm	135 rpm	124 rpm
	50 (13.2)	92 (814)	218 (1929)	262 (2319)	304 (3960)	384 (3398)	486 (4301)
	157 rpm	157 rpm	155 rpm	154 rpm	151 rpm	141 rpm	
Max Cont.	60 (15.85)	89 (788)	215 (1903)	258 (2283)	299 (2646)	379 (3554)	479 (4239)
		189 rpm	188 rpm	187 rpm	185 rpm	182 rpm	171 rpm
Max Int.	75 (19.75)	69 (611)	194 (1717)	237 (2097)	278 (2460)	355 (3141)	
		236 rpm	235 rpm	234 rpm	232 rpm	229 rpm	

H 400 (23/226)		387 CM <sup>3</sup> /REV 23.61 IN <sup>3</sup> /REV				Max Cont.	Max Int.
Pressure	bar (psi)	30 (44)	60 (880)	70 (1030)	80 (1175)	85 (1251)	125 (1840)
F L O W	LPM (GPM)	Torque Nm (in.Lbs) Speed Specification					
	8 (2.10)	147 (140)	304 (2690)	354 (3133)			
		20 rpm	19 rpm	16 rpm			
	15 (3.95)	147 (1301)	308 (2726)	359 (3177)	408 (3611)	435 (3850)	532 (4708)
		37 rpm	36 rpm	35 rpm	33 rpm	32 rpm	25 rpm
	20 (5.25)	144 (1274)	305 (2699)	358 (3168)	406 (3602)	435 (34850)	533 (4717)
		50 rpm	49 rpm	47 rpm	45 rpm	43 rpm	38 rpm
	30 (7.90)	139 (1230)	302 (2664)	352 (3115)	402 (3558)	430 (3806)	530 (4691)
		74 rpm	73 rpm	72 rpm	70 rpm	68 rpm	62 rpm
	35 (9.20)	133 (1177)	294 (2602)	345 (3053)	396 (3505)	423 (3744)	525 (4646)
		86 rpm	86 rpm	85 rpm	82 rpm	80 rpm	75 rpm
	45 (11.9)	125 (1106)	287 (2540)	339 (3000)	389 (3443)	416 (3682)	517 (4575)
		111 rpm	111 rpm	109 rpm	106 rpm	105 rpm	100 rpm
	50 (13.2)	117 (1035)	278 (2460)	330 (2920)	282 (3381)	409 (3620)	509 (4505)
	124 rpm	124 rpm	122 rpm	120 rpm	119 rpm	113 rpm	
Max Cont.	60 (15.85)	112 (991)	274 (2425)	326 (2177)	377 (3337)	404 (3575)	505 (4469)
		149 rpm	149 rpm	147 rpm	145 rpm	144 rpm	137 rpm
Max Int.	75 (19.75)	88 (779)	246 (2177)	298 (2637)	351 (3106)	376 (3328)	
		185 rpm	185 rpm	185 rpm	182 rpm	181 rpm	

# HIGH TORQUE, LOW SPEED MOTORS

## S-SERIES

The -103(S) series advanced GEROLER™ gear set hydraulic motor, with spool valve flow distribution, is a compact, low noise, high efficient high torque low speed design. The GEROLER™ gear set also provides higher efficiencies at start up and during low speed conditions.

The special design of the valve linkage and high pressure capability of the shaft seal provides a long operating life and these motors can be used in either series or parallel operation.

The low weight advanced construction design is manufactured in accordance with the requirements of ISO 9001:2000 quality system.

### Technical Specifications

			FLUIDDYNE 103 S SERIES								
			DISPLACEMENT cm <sup>3</sup> /r (in <sup>3</sup> /r)								
FluidDyne			50 cm <sup>3</sup> (3.0)	80 cm <sup>3</sup> (4.9)	100 cm <sup>3</sup> (6.1)	125 cm <sup>3</sup> (7.6)	160 cm <sup>3</sup> (9.6)	200 cm <sup>3</sup> (12.2)	250 cm <sup>3</sup> (15.4)	315 cm <sup>3</sup> (19.2)	370 cm <sup>3</sup> (22.6)
Char-Lynn reference			59 cm <sup>3</sup> (3.6)	74 cm <sup>3</sup> (4.5)	97 cm <sup>3</sup> (5.9)	120 cm <sup>3</sup> (7.3)	159 cm <sup>3</sup> (9.7)	185 cm <sup>3</sup> (11.3)	231 cm <sup>3</sup> (14.1)	293 cm <sup>3</sup> (17.9)	370 cm <sup>3</sup> (22.6)
MOUNTING	Shafts	PORTS									
2 BOLT FLANGE MOUNT	1" STRAIGHT WOODRUFF KEY	7/8" -14 O-RING	WF1031537	WF1031034	WF1031035	WF1031538	WF1031036	WF1031037	WF1031038	WF1031039	WF1031040
		1/2" NPTF O-RING	WF1031540	WF1031026	WF1031027	WF1031541	WF1031028	WF1031029	WF1031030	WF1031031	WF1031032
		MANIFOLD	WF1031543	WF1031042	WF1031043	WF1031544	WF1031044	WF1031045	WF1031046	WF1031047	WF1031048
	1" SAE 6B SPLINED	7/8" -14 O-RING	WF1031552	WF1031082	WF1031083	WF1031553	WF1031084	WF1031085	WF1031086	WF1031087	WF1031088
		1/2" NPTF O-RING	WF1031555	WF1031074	WF1031075	WF1031556	WF1031076	WF1031077	WF1031078	WF1031079	WF1031080
4 BOLT FLANGE MOUNT	1" STRAIGHT WOODRUFF KEY	7/8" -14 O-RING	WF1031570	WF1031010	WF1031011	WF1031571	WF1031012	WF1031013	WF1031014	WF1031015	WF1031016
		1/2" NPTF O-RING	WF1031573	WF1031002	WF1031003	WF1031574	WF1031004	WF1031005	WF1031006	WF1031007	WF1031008
	1" SAE 6B SPLINED	7/8" -14 O-RING	WF1031579	WF1031058	WF1031059	WF1031580	WF1031060	WF1031061	WF1031062	WF1031063	WF1031064
		1/2" NPTF O-RING	WF1031582	WF1031050	WF1031051	WF1031583	WF1031052	WF1031053	WF1031054	WF1031055	WF1031056
4 BOLT MAGNETO MOUNT	1" STRAIGHT WOODRUFF KEY	7/8" -14 O-RING	-	WF1032725	WF1033196	WF1033196	WF1033197	WF1031665	WF1033198	WF1033199	-
	1" SAE 6B SPLINED	7/8" -14 O-RING	-	-	WF1032711	-	WF1033176	WF1032750	WF1031652	WF1031653	-
Max Torque (in-lbs)	Continuous		884	1,680	2,123	2,582	3,210	3,166	3,113	3,184	3,714
	Intermittent		1,114	1,946	2,476	3,007	3,803	3,962	4,157	4,157	4,847
Max Pressure (PSI)	Continuous		2,031	2,539	2,539	2,539	2,394	1,886	1,596	1,233	1,233
	Intermittent		2,539	2,901	2,901	2,901	2,901	2,539	2,031	1,668	1,668
Max Flow (GPM)	Continuous		11	16	16	16	16	16	16	16	16
	Intermittent		13	20	20	20	20	20	20	20	20
Max RPM	Continuous		755	750	600	475	375	300	240	190	160
	Intermittent		970	940	750	600	470	375	300	240	200
Weight (LBS)			15	15	15	16	17	18	19	20	21

Continuous = maximum of continuous operation

Intermittent = maximum operating range for 6 seconds per minute

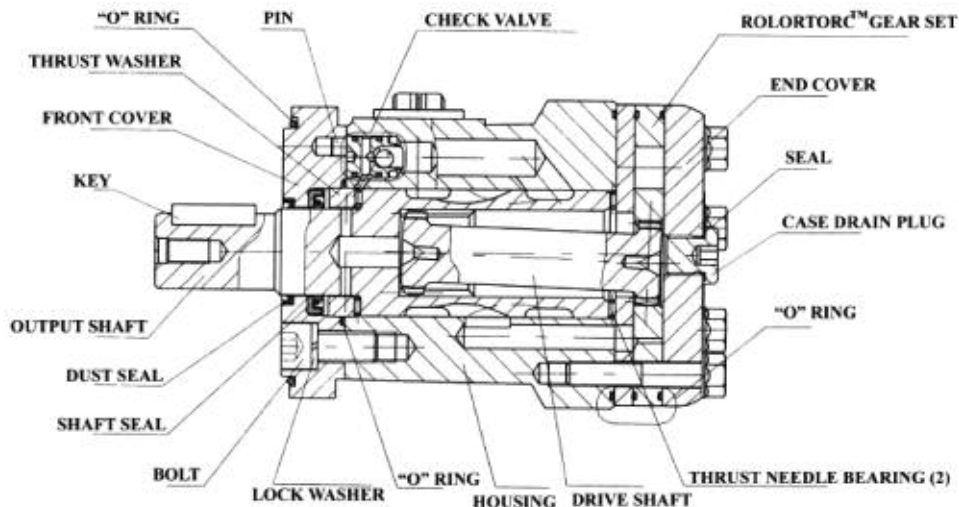

## S-SERIES SHAFT DATA

01

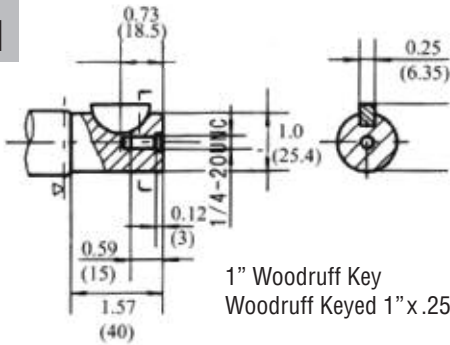

1" Woodruff Key  
Woodruff Keyed 1"x.25

02

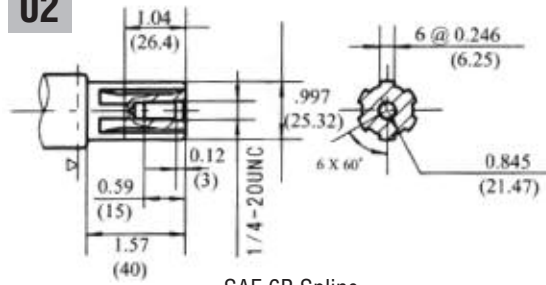

SAE 6B Spline

## S SERIES MODEL CODE

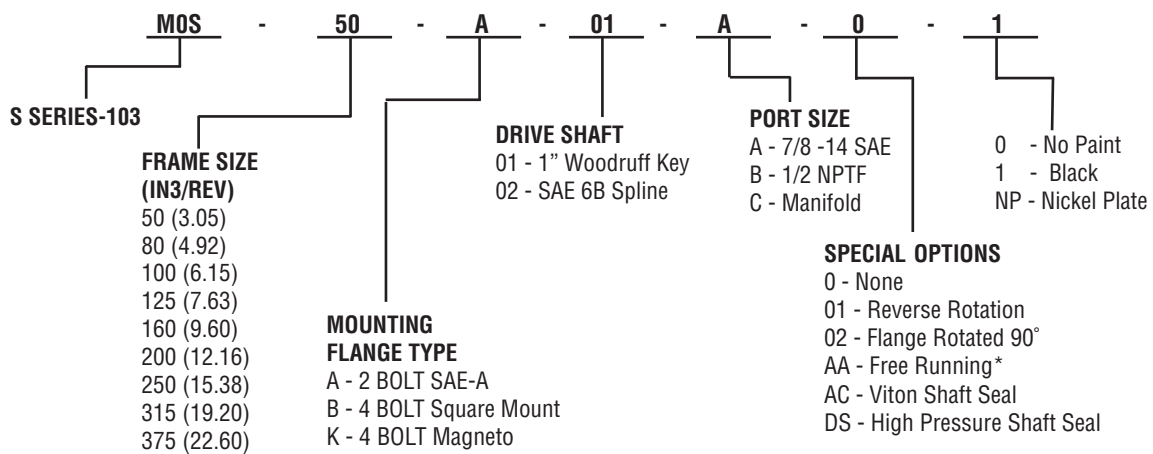

Additional flange and drive shaft options available please consult factory

\* Available on selected models

## S SERIES INSTALLATION DATA

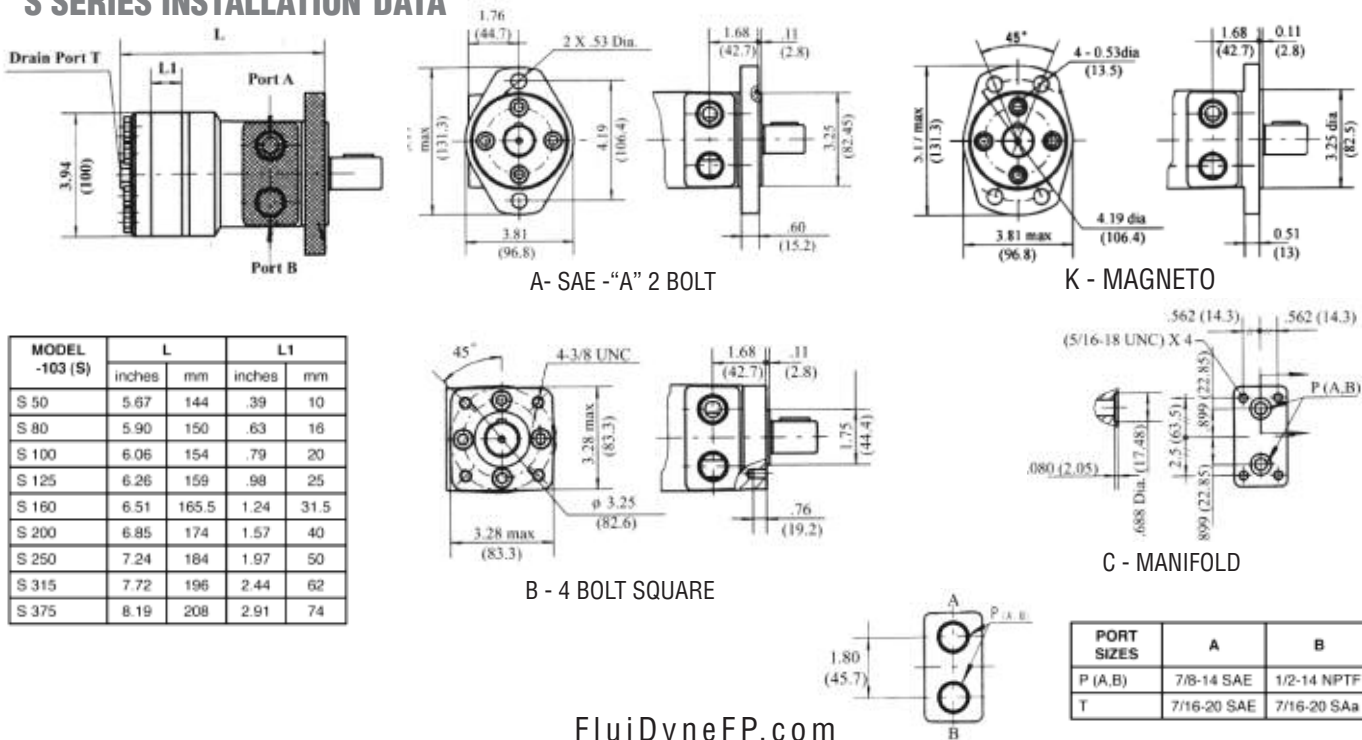

# HIGH TORQUE, LOW SPEED MOTORS

## S SERIES TECHNICAL DATA

### SHAFT SEAL RATED PRESSURE

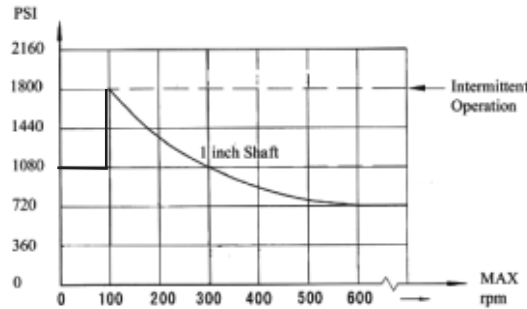
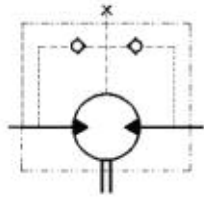

### CASE DRAIN

In applications without a motor drain line, the pressure exerted on the shaft seal is marginally in excess of the return line pressure. When the drain line is used the pressure exerted on the shaft seal is equal to the return line pressure.

### SHAFT ROTATION DIRECTION

STANDARD ROTATION VIEWED FROM SHAFT END

Port A pressurized = CW rotation  
 Port B pressurized = CCW rotation

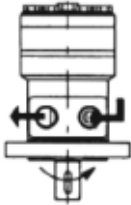

### RADIAL FORCES

Status of the shaft's radial force

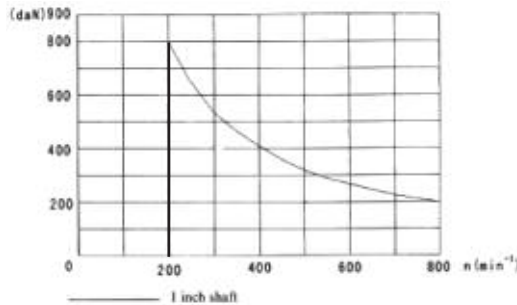

$$F_r = \frac{800 \cdot 2500}{n \cdot 95 + L} \text{ daN}$$

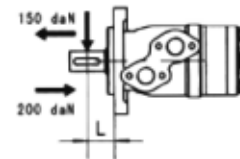

$F_r$  = Radial Force (daN)  
 $L$  = Distance (mm)  
 $n$  = Speed (rpm)

Round-flange  $L=30\text{mm}$   
 Square-flange  $L=24\text{mm}$

S 50		51.3 Cm <sup>3</sup> /Rev 3.13 In <sup>3</sup> /Rev					Max Cont.	Max Int.		
Pressure bar (psi)		50 (376)	70 (1030)	90 (1352)	100 (1470)	120 (1766)	140 (2060)	160 (2355)	175 (2576)	
FLOW	LPM (GPM)	Torque Nm (in.Lbs) Speed Specification								
	5 (1.32)	35 (310)	45 (398)	61 (540)	67 (593)	77 (681)	88 (779)			
		95 rpm	84 rpm	76 rpm	73 rpm	69 rpm	46 rpm			
	10 (2.65)	36 (316)	46 (407)	62 (549)	69 (611)	80 (708)	95 (841)	108 (956)	120 (1062)	
		184 rpm	176 rpm	165 rpm	162 rpm	150 rpm	130 rpm	111 rpm	84 rpm	
	15 (3.95)	35 (310)	49 (434)	63 (558)	73 (646)	88 (779)	100 (885)	109 (965)	123 (1089)	
		283 rpm	277 rpm	269 rpm	261 rpm	250 rpm	230 rpm	211 rpm	185 rpm	
	20 (5.26)	34 (301)	47 (416)	61 (540)	69 (611)	83 (735)	96 (850)	109 (965)	126 (1115)	
		377 rpm	375 rpm	365 rpm	361 rpm	346 rpm	330 rpm	308 rpm	276 rpm	
	25 (6.60)	34 (301)	45 (398)	61 (540)	69 (611)	81 (717)	96 (850)	109 (965)	126 (1115)	
	476 rpm	468 rpm	460 rpm	453 rpm	438 rpm	423 rpm	395 rpm	361 rpm		
Max Cont.	30 (7.90)	33 (292)	44 (389)	60 (531)	67 (593)	80 (708)	95 (841)	108 (956)	126 (1115)	
		576 rpm	569 rpm	561 rpm	554 rpm	542 rpm	531 rpm	500 rpm	465 rpm	
	35 (9.20)	31 (274)	42 (372)	59 (522)	66 (584)	80 (708)	93 (823)	107 (947)	124 (1097)	
		689 rpm	665 rpm	657 rpm	654 rpm	638 rpm	623 rpm	598 rpm	561 rpm	
Max Int.	40 (10.50)	30 (266)	41 (363)	58 (513)	66 (584)	79 (699)	92 (814)	106 (938)	122 (1080)	
		760 rpm	758 rpm	753 rpm	750 rpm	738 rpm	727 rpm	700 rpm	670 rpm	
Max Int.	45 (11.85)	29.5 (281)	40 (354)	57 (504)	65 (575)	78 (690)	90 (797)	105 (929)	121 (1071)	
		856 rpm	856 rpm	850 rpm	845 rpm	835 rpm	815 rpm	799 rpm	780 rpm	

S 80		80.6 Cm <sup>3</sup> /Rev 4.9 In <sup>3</sup> /Rev					Max Cont.	Max Int.		
Pressure bar (psi)		50 (376)	70 (1030)	90 (1352)	100 (1470)	120 (1766)	140 (2060)	160 (2355)	175 (2576)	
FLOW	LPM (GPM)	Torque Nm (in.Lbs) Speed Specification								
	10 (2.65)	55 (487)	77 (681)	98 (867)	107 (947)	130 (1151)	149 (1319)	170 (1505)	180 (1593)	
		115 rpm	109 rpm	106 rpm	101 rpm	91 rpm	75 rpm	53 rpm	45 rpm	
	20 (5.25)	50 (443)	81.6 (722)	105 (938)	118 (1044)	132 (1168)	160 (1416)	178 (1575)	189 (1673)	
		239 rpm	235 rpm	227 rpm	224 rpm	209 rpm	196 rpm	172 rpm	160 rpm	
	30 (7.90)	48 (425)	74 (655)	97 (858)	114 (1009)	131 (1159)	150 (1328)	179 (1584)	190 (1682)	
		364 rpm	360 rpm	357 rpm	345 rpm	332 rpm	321 rpm	300 rpm	284 rpm	
	40 (10.50)	45 (398)	71 (628)	95 (841)	105 (929)	128 (1133)	149 (1319)	177 (1566)	188 (1664)	
		488 rpm	483 rpm	475 rpm	472 rpm	460 rpm	447 rpm	420 rpm	408 rpm	
	50 (13.15)	42 (372)	70 (620)	90 (797)	98 (867)	125 (1106)	147 (1301)	171 (1513)	187 (1655)	
Max Cont.		619 rpm	615 rpm	607 rpm	598 rpm	593 rpm	568 rpm	547 rpm	535 rpm	
	60 (15.80)	38 (336)	63 (558)	85 (752)	95 (841)	118 (1044)	142 (1257)	169 (1496)	185 (1637)	
		740 rpm	725 rpm	721 rpm	715 rpm	707 rpm	688 rpm	667 rpm	657 rpm	
	70 (18.40)	36 (319)	58 (513)	80 (708)	89 (788)	112 (991)	139 (1230)	164 (1451)	179 (1584)	
Max Int.		860 rpm	853 rpm	839 rpm	837 rpm	823 rpm	811 rpm	790 rpm	776 rpm	
	75 (19.75)	29 (257)	56 (496)	77 (681)	85 (752)	110 (974)	133 (1177)	161 (1425)	177 (1566)	
	925 rpm	915 rpm	910 rpm	899 rpm	888 rpm	871 rpm	853 rpm	837 rpm		

# HIGH TORQUE, LOW SPEED MOTORS

1-800-842-5377

## S SERIES TECHNICAL DATA

S 100		100.8 Cm <sup>3</sup> /Rev 6.15 in <sup>3</sup> /Rev				Max Cont.	Max Int.			
Pressure bar (psi)		50 (376)	70 (1030)	90 (1352)	100 (1470)	120 (1766)	140 (2060)	160 (2355)	175 (2576)	
F L O W	LPM (GPM)	Torque Nm (In.Lbs) Speed Specification								
	10 (2.65)	70 (620) 99 rpm	100 (885) 95 rpm	122 (1080) 87 rpm	138 (1221) 84 rpm	159 (1407) 74 rpm	182 (1611) 63 rpm	210 (1859) 52 rpm	222 (1965) 44 rpm	
	20 (5.25)	68 (602) 199 rpm	95 (841) 194 rpm	123 (1089) 188 rpm	143 (1266) 182 rpm	165 (1460) 175 rpm	200 (1770) 162 rpm	221 (1956) 150 rpm	238 (2106) 138 rpm	
	30 (7.90)	62 (547) 299 rpm	94 (832) 294 rpm	121 (1071) 288 rpm	140 (1239) 284 rpm	164 (1451) 278 rpm	194 (1717) 263 rpm	220 (1947) 249 rpm	240 (2124) 236 rpm	
	40 (10.50)	59 (522) 400 rpm	88 (779) 398 rpm	119 (1053) 387 rpm	134 (1186) 385 rpm	161 (1425) 380 rpm	192 (1699) 366 rpm	218 (1929) 350 rpm	238 (2106) 336 rpm	
	50 (13.15)	55 (487) 498 rpm	83 (735) 496 rpm	117 (1035) 488 rpm	125 (1106) 484 rpm	157 (1389) 475 rpm	185 (1637) 464 rpm	217 (1920) 450 rpm	235 (2080) 436 rpm	
	60 (15.80)	48 (425) 599 rpm	79 (699) 595 rpm	110 (974) 587 rpm	119 (1053) 585 rpm	152 (1345) 579 rpm	180 (1593) 569 rpm	214 (1894) 552 rpm	233 (2062) 538 rpm	
	70 (18.40)	43 (381) 699 rpm	70 (620) 693 rpm	100 (885) 687 rpm	112 (991) 683 rpm	142 (1257) 679 rpm	170 (1505) 668 rpm	201 (1789) 648 rpm	229 (2027) 636 rpm	
	Max Cont.	75 (19.75)	39 (345)	63 (558)	97 (858)	105 (929)	140 (1239)	167 (1478)	197 (1743)	227 (2009)
	Max Int.		748 rpm	741 rpm	737 rpm	735 rpm	720 rpm	713 rpm	697 rpm	686 rpm

S 125		124.9 Cm <sup>3</sup> /Rev 7.63 in <sup>3</sup> /Rev				Max Cont.	Max Int.			
Pressure bar (psi)		50 (376)	70 (1030)	90 (1352)	100 (1470)	120 (1766)	140 (2060)	160 (2355)	175 (2576)	
F L O W	LPM (GPM)	Torque Nm (In.Lbs) Speed Specification								
	10 (2.65)	90 (797) 73 rpm	122 (1080) 71 rpm	160 (1416) 66 rpm	173 (1531) 63 rpm	205 (1814) 55 rpm	237 (2097) 42 rpm	258 (2283) 23 rpm	270 (2390) 14 rpm	
	20 (5.25)	85 (752) 154 rpm	118 (1044) 152 rpm	159 (1407) 150 rpm	172 (1522) 145 rpm	208 (1841) 138 rpm	250 (2213) 123 rpm	278 (2460) 109 rpm	292 (2584) 91 rpm	
	30 (7.90)	82 (726) 237 rpm	107 (947) 236 rpm	158 (1398) 233 rpm	164 (1451) 226 rpm	206 (1823) 219 rpm	241 (2133) 207 rpm	277 (2451) 192 rpm	291 (2575) 170 rpm	
	40 (10.50)	79 (699) 315 rpm	105 (929) 313 rpm	150 (1320) 309 rpm	161 (1425) 307 rpm	204 (1895) 302 rpm	238 (2106) 297 rpm	275 (2434) 272 rpm	289 (2558) 254 rpm	
	50 (13.15)	75 (664) 398 rpm	96 (850) 397 rpm	145 (1283) 395 rpm	160 (1416) 391 rpm	198 (1752) 381 rpm	236 (2089) 368 rpm	262 (2319) 353 rpm	282 (2496) 337 rpm	
	60 (15.80)	62 (549) 475 rpm	95 (841) 473 rpm	139 (1230) 471 rpm	158 (1938) 470 rpm	183 (1389) 463 rpm	222 (1965) 450 rpm	254 (2248) 427 rpm	279 (2469) 416 rpm	
	70 (18.40)	59 (522) 554 rpm	83 (735) 553 rpm	125 (1106) 551 rpm	150 (1328) 550 rpm	178 (1575) 546 rpm	212 (1876) 538 rpm	250 (2213) 514 rpm	262 (2319) 500 rpm	
	Max Cont.	75 (19.75)	56 (496)	80 (708)	122 (1080)	145 (1283)	172 (1522)	205 (1814)	245 (2168)	261 (2310)
	Max Int.		598 rpm	597 rpm	593 rpm	590 rpm	586 rpm	577 rpm	551 rpm	537 rpm

S 160		157.2 Cm <sup>3</sup> /Rev 9.60 in <sup>3</sup> /Rev				Max Cont.	Max Int.			
Pressure bar (psi)		50 (376)	70 (1030)	90 (1352)	100 (1470)	120 (1766)	140 (2060)	160 (2355)	175 (2576)	
F L O W	LPM (GPM)	Torque Nm (In.Lbs) Speed Specification								
	10 (2.65)	115 (1018) 58 rpm	160 (14160) 55 rpm	203 (1797) 52 rpm	220 (1947) 50 rpm	260 (2301) 44 rpm	300 (2655) 38 rpm	340 (3009) 34 rpm	363 (3204) 26 rpm	
	20 (5.25)	114 (1009) 119 rpm	160 (1416) 115 rpm	205 (1814) 111 rpm	230 (2036) 108 rpm	265 (2345) 103 rpm	320 (2832) 95 rpm	355 (3142) 84 rpm	380 (3363) 76 rpm	
	30 (7.90)	105 (929) 184 rpm	158 (1398) 181 rpm	202 (1788) 177 rpm	221 (1956) 172 rpm	261 (2310) 165 rpm	305 (2699) 153 rpm	344 (3044) 134 rpm	378 (3345) 130 rpm	
	40 (10.50)	100 (885) 246 rpm	145 (1283) 244 rpm	196 (1735) 239 rpm	218 (1929) 237 rpm	257 (2274) 230 rpm	299 (2646) 218 rpm	340 (3009) 199 rpm	374 (3310) 184 rpm	
	50 (13.15)	90 (797) 307 rpm	140 (1239) 305 rpm	190 (1682) 302 rpm	209 (1850) 300 rpm	250 (2213) 292 rpm	295 (2611) 280 rpm	336 (2974) 262 rpm	366 (3239) 244 rpm	
	60 (15.80)	84 (743) 370 rpm	136 (1204) 368 rpm	180 (1593) 364 rpm	199 (1761) 362 rpm	240 (2124) 355 rpm	286 (2531) 342 rpm	330 (2921) 334 rpm	360 (3186) 304 rpm	
	70 (18.40)	65 (575) 435 rpm	120 (1062) 434 rpm	164 (1451) 430 rpm	180 (1593) 427 rpm	223 (1974) 416 rpm	280 (2478) 405 rpm	320 (2832) 335 rpm	350 (3098) 366 rpm	
	Max Cont.	75 (19.75)	59 (522)	116 (1026)	158 (1398)	175 (1549)	220 (1947)	272 (2407)	314 (2779)	342 (3027)
	Max Int.		465 rpm	462 rpm	458 rpm	456 rpm	447 rpm	433 rpm	416 rpm	395 rpm

## S SERIES TECHNICAL DATA

S 200		199.2 Cm <sup>3</sup> /Rev 12.16 in <sup>3</sup> /Rev				Max Cont.		Max Int.		
Pressure bar (psi)		50 (376)	70 (1030)	90 (1352)	100 (1470)	120 (1766)	140 (2060)	175 (2576)		
F L O W	LPM (GPM)	Torque Nm (in.Lbs) Speed Specification								
	10 (2.65)	148 (1310) 49 rpm	205 (1814) 47 rpm	255 (2257) 45 rpm	290 (2567) 43 rpm	327 (2894) 40 rpm	370 (3275) 30 rpm	442 (3912) 24 rpm		
	20 (5.25)	140 (1239) 99 rpm	202 (1788) 97 rpm	250 (2213) 93 rpm	323 (2859) 90 rpm	330 (2921) 86 rpm	411 (3637) 78 rpm	448 (3965) 65 rpm		
	30 (7.90)	130 (1151) 149 rpm	193 (1708) 146 rpm	241 (2133) 140 rpm	307 (2717) 136 rpm	325 (2876) 131 rpm	377 (3336) 122 rpm	445 (3938) 105 rpm		
	40 (10.50)	125 (1106) 200 rpm	186 (1646) 197 rpm	232 (2053) 192 rpm	305 (2699) 188 rpm	313 (2770) 181 rpm	390 (3452) 170 rpm	436 (3860) 149 rpm		
	50 (13.15)	120 (1062) 250 rpm	177 (1566) 247 rpm	225 (1991) 242 rpm	295 (2611) 238 rpm	305 (2699) 231 rpm	382 (3381) 218 rpm	427 (3779) 193 rpm		
	60 (15.80)	110 (974) 300 rpm	166 (1469) 298 rpm	221 (1956) 291 rpm	285 (25220) 287 rpm	292 (2584) 282 rpm	372 (3292) 268 rpm	419 (3708) 236 rpm		
	70 (18.40)	98 (867) 350 rpm	150 (1328) 347 rpm	205 (1814) 342 rpm	244 (2159) 338 rpm	278 (2461) 331 rpm	331 (2929) 318 rpm	410 (3629) 282 rpm		
	Max Cont.	75 (19.75)	85 (752) 375 rpm	141 (1248) 372 rpm	199 (1761) 366 rpm	235 (2080) 362 rpm	268 (2372) 357 rpm	323 (2859) 343 rpm	400 (3540) 310 rpm	
	Max Int.									

S 250		252 Cm <sup>3</sup> /Rev 15.39 in <sup>3</sup> /Rev				Max Cont.		Max Int.		
Pressure bar (psi)		50 (376)	70 (1030)	90 (1352)	100 (1470)	120 (1766)	140 (2060)	160 (2355)	175 (2576)	
F L O W	LPM (GPM)	Torque Nm (in.Lbs) Speed Specification								
	10 (2.65)	115 (1018) 40 rpm	180 (1593) 38 rpm	251 (2221) 37 rpm	295 (2611) 35 rpm	350 (3098) 32 rpm	380 (3363) 30 rpm	470 (4160) 22 rpm	535 (4735) 16 rpm	
	20 (5.25)	110 (974) 79 rpm	178 (1575) 78 rpm	252 (2230) 75 rpm	294 (2602) 74 rpm	352 (3115) 70 rpm	385 (3407) 68 rpm	470 (4160) 57 rpm	548 (4850) 48 rpm	
	30 (7.90)	100 (885) 120 rpm	170 (1505) 119 rpm	248 (2195) 117 rpm	285 (2522) 116 rpm	348 (3080) 110 rpm	381 (3372) 107 rpm	469 (4151) 95 rpm	545 (4823) 79 rpm	
	40 (10.50)	91 (805) 158 rpm	159 (1407) 157 rpm	232 (2053) 156 rpm	268 (2372) 154 rpm	332 (2938) 151 rpm	366 (3239) 148 rpm	460 (4071) 130 rpm	530 (4691) 110 rpm	
	50 (13.15)	81 (717) 200 rpm	148 (1310) 198 rpm	216 (1912) 196 rpm	252 (2230) 195 rpm	320 (2832) 163 rpm	352 (3115) 160 rpm	453 (4009) 152 rpm	521 (4611) 147 rpm	
	60 (15.80)	75 (664) 241 rpm	132 (1168) 240 rpm	201 (1769) 239 rpm	235 (2080) 237 rpm	305 (2699) 232 rpm	340 (3009) 228 rpm	433 (3832) 210 rpm	505 (4469) 180 rpm	
	70 (18.40)	50 (443) 280 rpm	117 (1035) 279 rpm	189 (1673) 277 rpm	220 (1947) 276 rpm	290 (2567) 271 rpm	320 (2832) 268 rpm	412 (3646) 250 rpm	495 (4381) 215 rpm	
	Max Cont.	75 (19.75)	42 (372) 300 rpm	105 (929) 299 rpm	180 (1593) 298 rpm	211 (1867) 297 rpm	281 (2487) 295 rpm	310 (2744) 289 rpm	405 (3584) 272 rpm	486 (4301) 239 rpm
	Max Int.									

S 315		314.5 Cm <sup>3</sup> /Rev 19.2 in <sup>3</sup> /Rev				Max Cont.		Max Int.		
Pressure bar (psi)		30 (442)	50 (376)	65 (957)	80 (1175)	90 (1325)	130 (1914)	135 (1987)		
F L O W	LPM (GPM)	Torque Nm (in.Lbs) Speed Specification								
	10 (2.65)	135 (1195) 31 rpm	215 (1903) 29 rpm	279 (2469) 28 rpm	343 (3036) 27 rpm	383 (3390) 27 rpm	515 (4558) 24 rpm	550 (4868) 22 rpm		
	20 (5.25)	133 (1177) 62 rpm	216 (1912) 61 rpm	289 (2558) 60 rpm	349 (3089) 58 rpm	380 (3363) 57 rpm	508 (4496) 52 rpm	552 (4886) 50 rpm		
	30 (7.90)	125 (1106) 95 rpm	205 (1814) 92 rpm	275 (2434) 91 rpm	341 (3018) 90 rpm	375 (3319) 88 rpm	494 (4372) 81 rpm	543 (4801) 79 rpm		
	40 (10.50)	113 (1000) 123 rpm	195 (1726) 121 rpm	267 (2363) 120 rpm	335 (2965) 118 rpm	367 (3248) 117 rpm	485 (4292) 106 rpm	526 (4655) 104 rpm		
	50 (13.15)	92 (814) 155 rpm	170 (1505) 154 rpm	253 (2239) 152 rpm	321 (2841) 149 rpm	352 (3115) 147 rpm	474 (4195) 137 rpm	511 (4522) 133 rpm		
	60 (15.80)	80 (708) 190 rpm	160 (1416) 187 rpm	231 (2040) 193 rpm	305 (2699) 179 rpm	334 (2956) 176 rpm	458 (4053) 163 rpm	492 (4354) 157 rpm		
	70 (18.40)	57 (504) 222 rpm	136 (1204) 220 rpm	215 (1903) 217 rpm	285 (2522) 212 rpm	320 (2832) 208 rpm	444 (3929) 192 rpm	480 (4248) 185 rpm		
	Max Cont.	75 (19.75)	55 (487) 235 rpm	124 (1097) 234 rpm	205 (1814) 231 rpm	269 (2381) 227 rpm	308 (2726) 225 rpm	427 (3779) 408 rpm	469 (4151) 201 rpm	
	Max Int.									

# HIGH TORQUE, LOW SPEED MOTORS

1-800-842-5377

## S SERIES TECHNICAL DATA

S 375		370 Cm <sup>3</sup> /Rev 22.6 in <sup>3</sup> /Rev				Max Cont.	Max Int.		
Pressure bar (psi)		30 (442)	50 (376)	65 (957)	80 (1175)	90 (1325)	130 (1914)	135 (1987)	
<b>F L O W</b>	<b>LPM (GPM)</b>	<b>Torque Nm (in.Lbs) Speed Specification</b>							
	<b>10 (2.65)</b>	160 (1416) 26 rpm	270 (2390) 25 rpm	340 (3009) 24 rpm	420 (3717) 22 rpm	470 (4160) 21 rpm	550 (4868) 19 rpm	610 (5399) 17 rpm	
	<b>20 (5.25)</b>	159 (14070) 53 rpm	260 (2301) 52 rpm	340 (3009) 51 rpm	410 (3629) 49 rpm	470 (4160) 47 rpm	540 (4779) 42 rpm	605 (5354) 37 rpm	
	<b>30 (7.90)</b>	150 (1328) 79 rpm	255 (2257) 78 rpm	330 (2921) 77 rpm	400 (3540) 75 rpm	450 (3983) 73 rpm	530 (4691) 67 rpm	600 (5310) 60 rpm	
	<b>40 (10.50)</b>	135 (1195) 106 rpm	240 (2124) 105 rpm	310 (2744) 104 rpm	375 (3319) 102 rpm	430 (3805) 99 rpm	520 (4602) 93 rpm	590 (5222) 85 rpm	
	<b>50 (13.15)</b>	120 (1062) 134 rpm	230 (2036) 132 rpm	295 (2511) 131 rpm	360 (3186) 129 rpm	420 (3717) 126 rpm	505 (4469) 120 rpm	570 (5045) 110 rpm	
	<b>60 (15.80)</b>	98 (867) 159 rpm	210 (1859) 158 rpm	275 (2434) 157 rpm	340 (3009) 155 rpm	390 (3452) 153 rpm	490 (4337) 147 rpm	550 (4868) 135 rpm	
	<b>70 (18.40)</b>	75 (664) 187 rpm	175 (1549) 186 rpm	250 (2213) 185 rpm	320 (2832) 183 rpm	370 (3275) 180 rpm	465 (4115) 175 rpm	530 (4691) 160 rpm	
	<b>Max Cont.</b>	<b>75 (19.75)</b>	65 (575) 200 rpm	160 (1416) 199 rpm	230 (2036) 198 rpm	310 (2744) 195 rpm	360 (3186) 192 rpm	450 (3983) 187 rpm	515 (4558) 178 rpm
	<b>Max Int.</b>								

# HIGH TORQUE, LOW SPEED MOTORS

## 2000-SERIES

The 2000 series motor adapts the advanced Geroler™ gear set design with DISC flow distribution and high pressure. The output shaft tapered roller bearings permit high axial and radial forces offering a smooth operation during low pressure start up and high pressure operation. These low weight advanced construction design motors are manufactured in accordance with the requirements of the ISO 9001:2000 quality system.

### Technical Specifications

FluidDyne			DISPLACEMENT cm <sup>3</sup> /r (in <sup>3</sup> /r)								
			80 cm <sup>3</sup> (4.9)	100 cm <sup>3</sup> (6.2)	125 cm <sup>3</sup> (7.2)	160 cm <sup>3</sup> (9.6)	200 cm <sup>3</sup> (12.2)	250 cm <sup>3</sup> (15.3)	315 cm <sup>3</sup> (19.2)	394 cm <sup>3</sup> (24.0)	475 cm <sup>3</sup> (29.0)
Char Lynn reference			80 cm <sup>3</sup> (4.9)	100 cm <sup>3</sup> (6.2)	130 cm <sup>3</sup> (8.0)	160 cm <sup>3</sup> (9.6)	195 cm <sup>3</sup> (11.9)	245 cm <sup>3</sup> (14.9)	305 cm <sup>3</sup> (18.7)	395 cm <sup>3</sup> (24.0)	490 cm <sup>3</sup> (29.8)
MOUNTING	SHAFTS	PORTS									
2-BOLT SAE "A" FLANGE MOUNT	1" STRAIGHT W/KEY	7/8"-14 O-RING STAGGERED	WF1041001	WF1041002	WF1041003	WF1041004	WF1041005	WF1041006	WF1041007	WF1041143	-
		1 1/16"-12 O-RING 180° APART	WF1041037	WF1041038	WF1041039	WF1041040	WF1041041	WF1041042	WF1041043	WF1041044	-
	1 1/4" STRAIGHT W/KEY	7/8"-14 O-RING STAGGERED	WF1041022	WF1041023	WF1041024	WF1041025	WF1041026	WF1041027	WF1041028	WF1041228	WF1041420
		1 1/16"-12 O-RING 180° APART	WF1041061	WF1041062	WF1041063	WF1041064	WF1041065	WF1041066	WF1041067	WF1041068	WF1041421
	1 1/4" 14 TOOTH SPLINED	7/8"-14 O-RING STAGGERED	WF1041029	WF1041030	WF1041031	WF1041032	WF1041033	WF1041034	WF1041035	WF1041229	WF1041422
		1 1/16"-12 O-RING 180° APART	WF1041087	WF1041088	WF1041089	WF1041090	WF1041091	WF1041092	WF1041093	WF1041094	WF1041423
4-BOLT SQUARE FLANGE	1 1/4" 14 TOOTH SPLINED	G 1/2 (BSP)	WF1041376	WF1041377	WF1041378	WF1041379	WF1041380	WF1041381	WF1041382	WF1041383	WF1041660
2-BOLT SAE "B" MOUNT	1" SAE 8B SPLINE	7/8" O-RING STAGGERED	WF1041193	WF1041194	WF1041195	WF1041196	WF1041197	WF1041198	WF1041199	WF1041797	-
	7/8" 13 TOOTH		WF1041216	WF1041217	WF1041218	WF1041219	WF1041220	WF1041455	WF1043205	-	WF1043052
4-BOLT MAGNETO MOUNT	1 1/4" STRAIGHT W/KEY	7/8" O-RING STAGGERED	WF1041855	WF1041343	WF1041837	WF1041626	WF1041346	WF1041627	WF1041401	WF1041445	WF1041387
	1 1/4" 14 TOOTH SPLINED		WF1041700	WF1041449	WF1041374	WF1041701	WF1041415	WF1041491	WF1041406	WF1041769	WF1041901
BEARINGLESS		7/8" O-RING STAGGERED	WF1061008	WF1061009	WF1061010	WF1061011	WF1061012	WF1061013	WF1061014	WF1061015	WF1061047
Max Torque (in-Lbs)	Continuous		1,990	2,565	3,228	4,292	5,185	6,262	7,783	7,783	8,048
	Intermittent		2,211	2,830	3,538	4,776	5,704	7,128	8,490	8,490	8,490
Max Differential Pressure (PSI)	Continuous		2,576	2,576	2,576	3,045	3,045	2,900	2,900	2,320	2,030
	Intermittent		3,091	3,091	2,576	3,265	3,265	3,265	3,265	2,563	2,175
Max Flow (GPM)	Continuous		18	20	20	20	20	20	20	20	20
	Intermittent		21	24	24	24	24	24	24	24	24
Max RPM	Continuous		800	748	600	470	375	300	240	185	155
	Intermittent		990	900	720	560	450	360	280	225	185
Weight	Weight		22	22	23	24	24	26	27	29	32

Continuous = maximum of continuous operation

Intermittent = maximum operating range for 6 seconds per minute

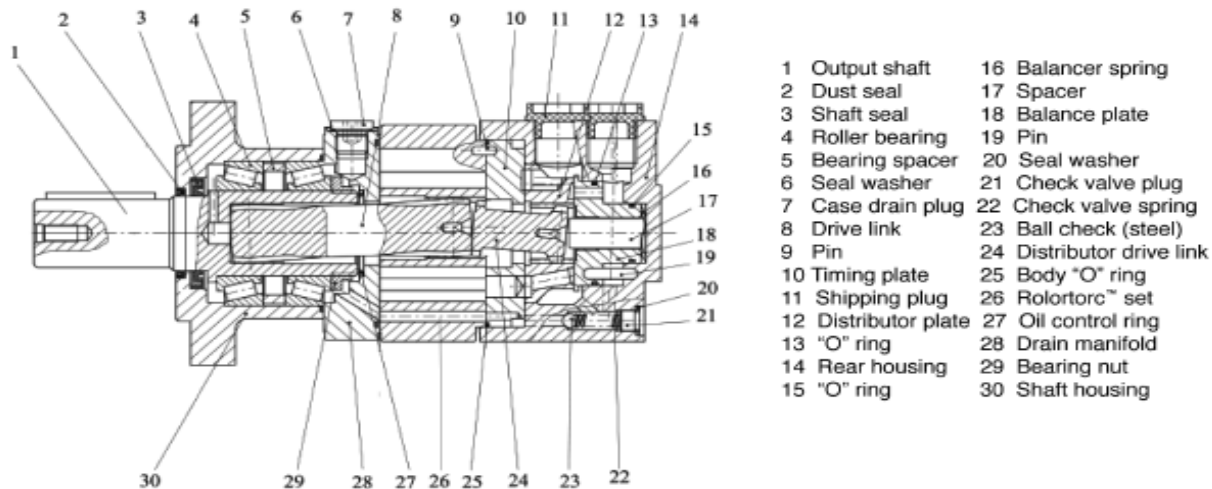



## 2000-SERIES SHAFT DATA

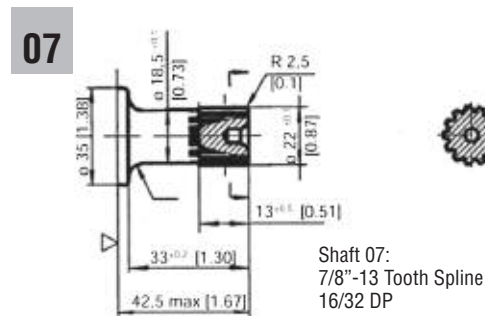
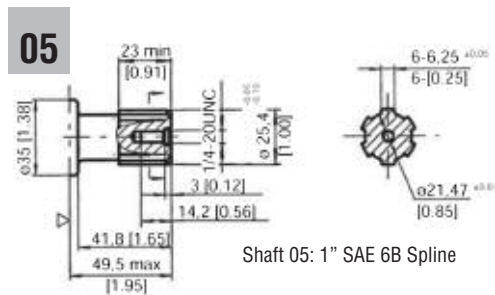
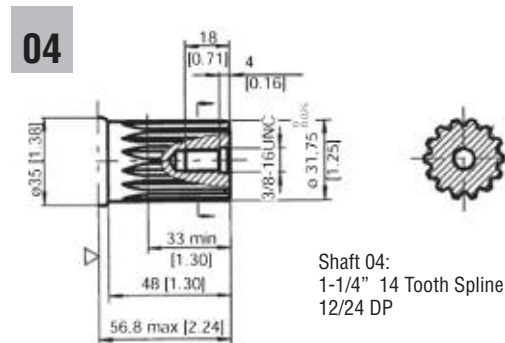
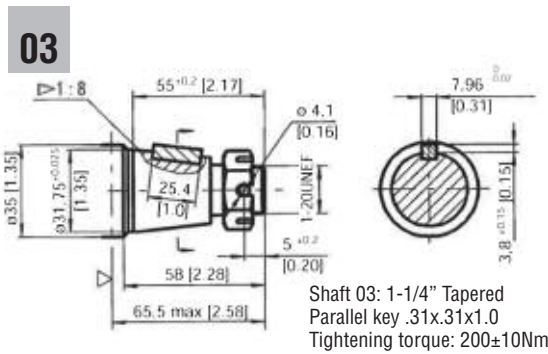
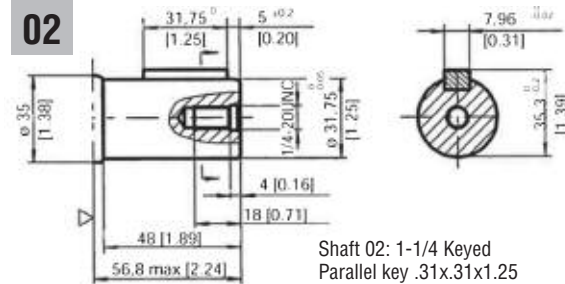
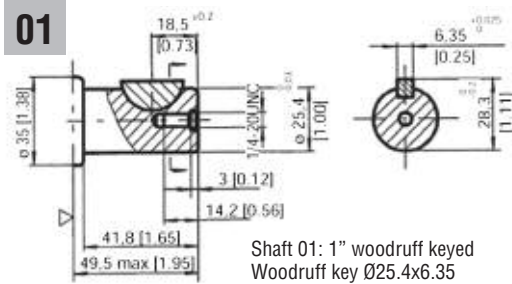

## MODEL CODE - 2000 SERIES

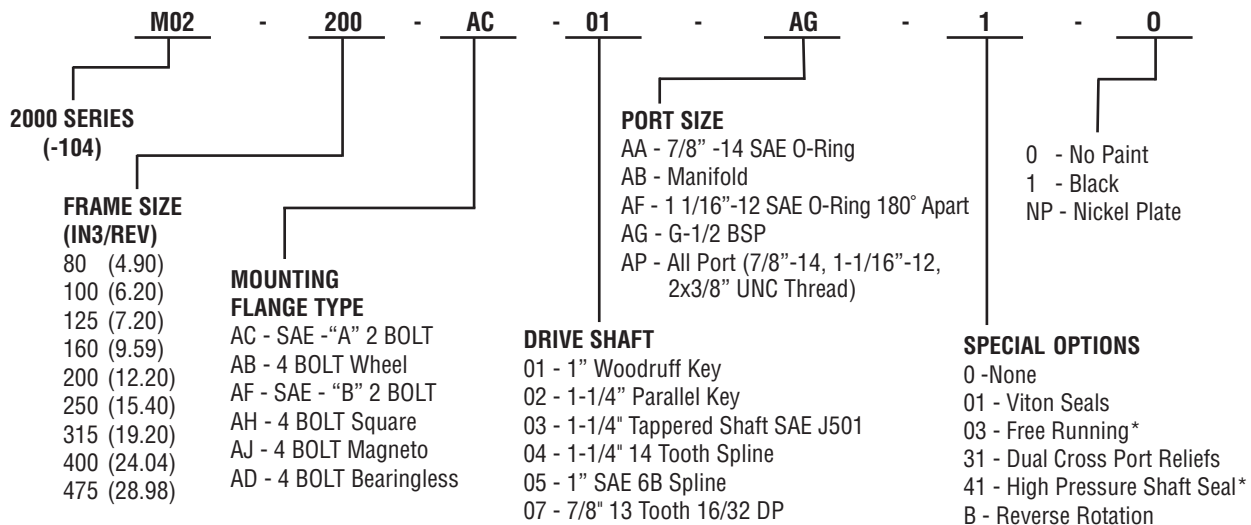

Additional flange and drive shaft options available please consult factory

\*Available on selected models

# HIGH TORQUE, LOW SPEED MOTORS

## 2000 SERIES INSTALLATION DATA

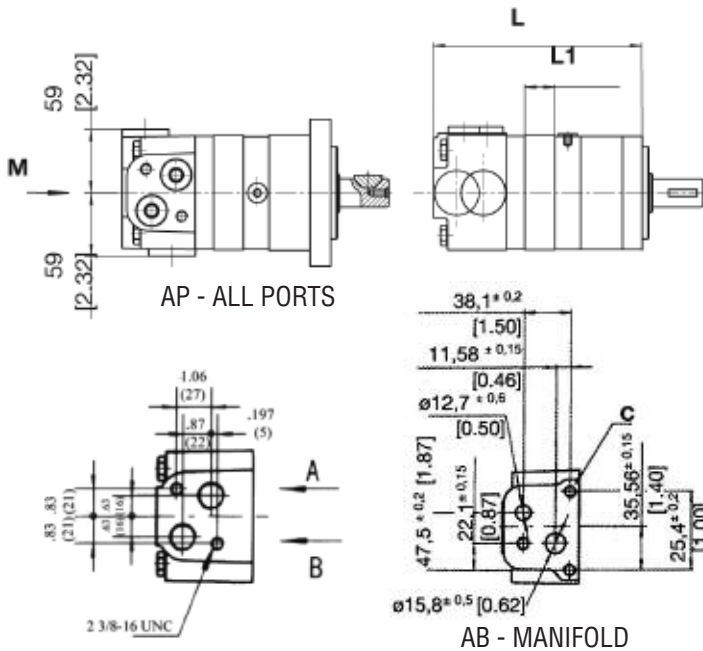

MODEL	[INCHES]		MILLIMETERS	
	L	L1	L	L1
80	[6.93]	[0.63]	176	16
100	[7.09]	[0.79]	180	20
125	[7.28]	[0.98]	185	25
160	[7.36]	[1.06]	187	27
200	[7.64]	[1.34]	194	34
250	[7.95]	[1.65]	202	42
315	[8.43]	[2.13]	214	54
400	[9.02]	[2.72]	229	69
475	[9.57]	[3.27]	243	83

### PORT & DRAIN PORT ORDERING CODES

ORDER CODE	AG	Depth	AA	Depth	AF	Depth
PORTS - A AND B	G 1/2	18 mm	M22x1.5	18 mm	7/8-14 O-ring	18 mm
TANK PORT - T	G 1/4	12 mm	M14x1.5	12 mm	7/16-20 UNF	12 mm

### DRAIN ON REAR HOUSING

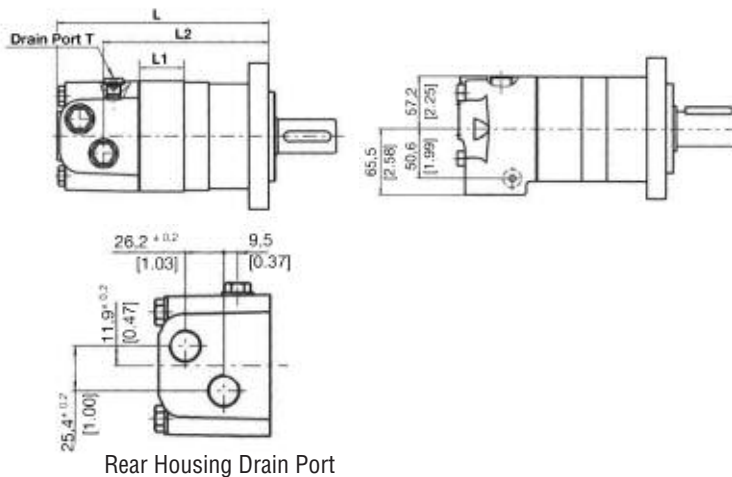

MODEL	[INCHES]			MILLIMETERS		
	L	L1	L2	L	L1	L2
80	[6.74]	[.52]	[4.85]	171	13	123.2
100	[6.89]	[.67]	[5.01]	175	17	127.2
125	[7.09]	[.87]	[5.21]	180	22	132.2
160	[7.27]	[1.09]	[5.43]	184.5	27.5	137.7
200	[7.60]	[1.39]	[5.72]	193	35.1	145.2
250	[8.07]	[1.85]	[6.19]	205	47	157.2
315	[8.55]	[2.33]	[6.67]	217	59	169.2
375	[9.02]	[2.80]	[7.14]	229	71	181.2

### 180° APART PORT MOUNTING DATA

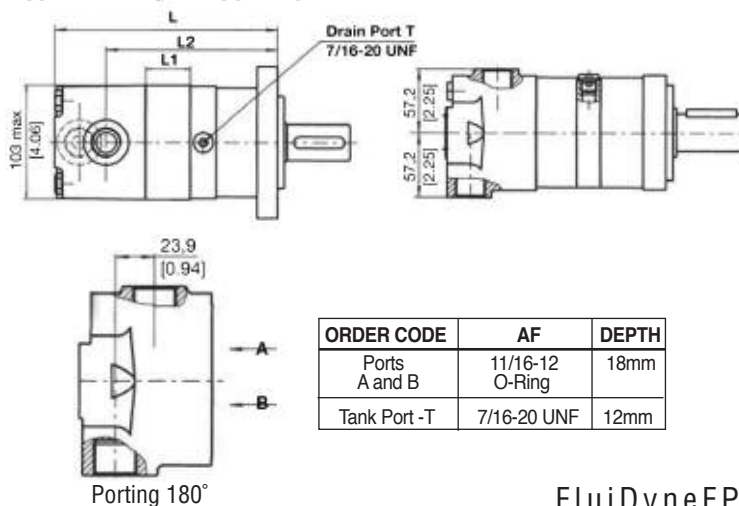

ORDER CODE	AF	DEPTH
Ports A and B	11/16-12 O-Ring	18mm
Tank Port -T	7/16-20 UNF	12mm

MODEL	[INCHES]			MILLIMETERS		
	L	L1	L2	L	L1	L2
80	[6.81]	[.51]	[4.95]	173	13	125.7
100	[6.97]	[.67]	[5.11]	177	17	129.7
125	[7.17]	[.87]	[5.30]	182	22	134.7
160	[7.38]	[1.08]	[5.52]	187.5	27.5	140.2
200	[7.68]	[1.38]	[5.81]	195	35.1	147.7
250	[8.15]	[1.85]	[6.29]	207	47	159.7
315	[8.62]	[2.32]	[6.76]	219	59	171.7
375	[9.09]	[2.80]	[7.23]	231	71	183.7

## 2000 SERIES INSTALLATION DATA

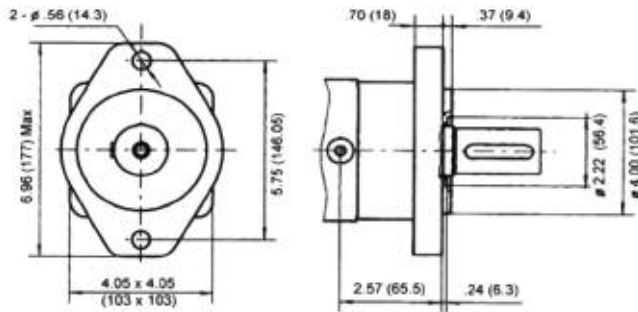

**AF - SAE "B" 2 BOLT**

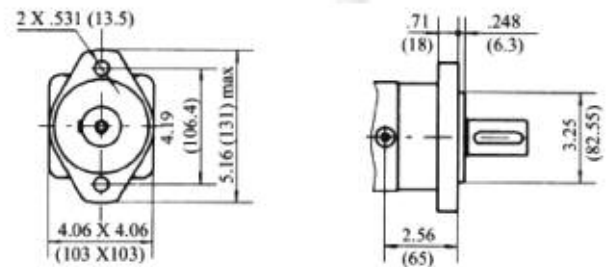

**AC - SAE "A" 2 BOLT**

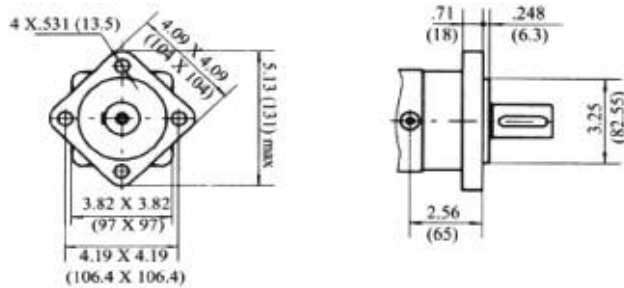

**AH - 4 BOLT SQUARE**

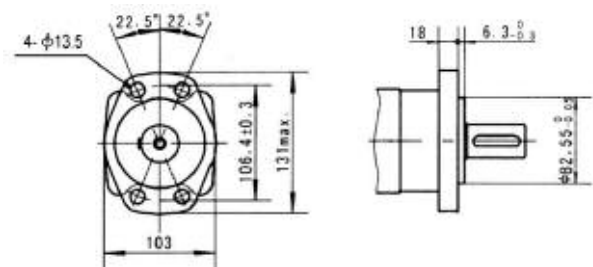

**AJ - 4 BOLT MAGNETO**

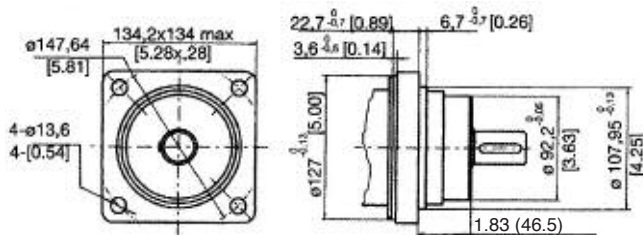

**AB - 4 BOLT WHEEL MOUNT**

# HIGH TORQUE, LOW SPEED MOTORS

## 2000 SERIES BEARINGLESS MOUNTING DATA

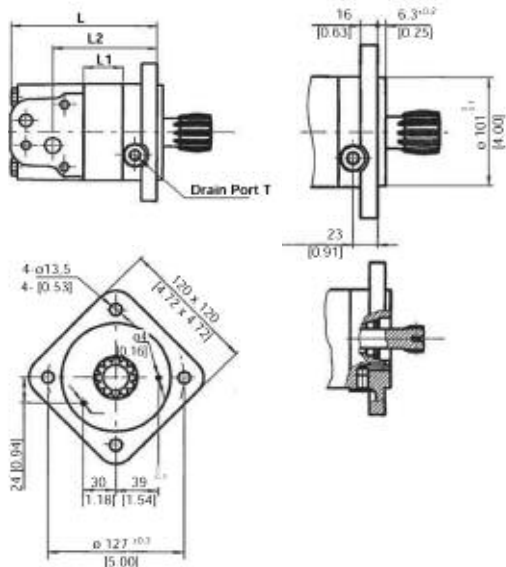

MODEL	[INCHES]			MILLIMETERS		
	L	L1	L2	L	L1	L2
80	[5.28]	[0.52]	[3.39]	134	13	86
100	[5.44]	[0.67]	[3.55]	138	17	90
125	[5.63]	[0.87]	[3.74]	143	22	95
160	[5.85]	[12.90]	[3.96]	148.5	27.5	100.5
200	[6.15]	[1.39]	[4.26]	156	35.1	108
250	[6.62]	[1.85]	[4.73]	168	47	120
315	[7.09]	[2.33]	[5.20]	180	59	132
375	[7.56]	[2.80]	[5.67]	192	71	144

## Internal Spline Data for 2000-Series Bearingless Motor

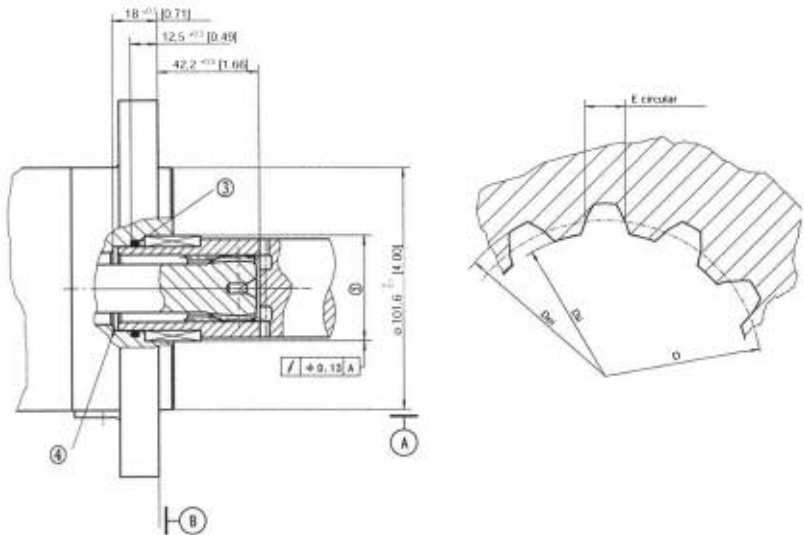

FILLET ROOT SIDE FIT		mm
NUMBER OF TEETH	Z	12
DIAMETRAL PITCH	DP	12/24
PRESSURE ANGLE	D	30°
PITCH DIA.	D	ø 25.4
MAJOR DIA.	Dei	ø 27.6 <sup>+0.14</sup> <sub>0</sub>
MINOR DIA.	Dii	ø 23.1 <sup>+0.12</sup> <sub>0</sub>
SPACE WIDTH CIRCULAR	E	4.282 <sup>+0.036</sup> <sub>0</sub>
DIMENSION BETWEEN TWO PINS (ø4)	Me	19.02-19.19

1. Internal spline in mating part to be as follows: Material to be ASTM A304, 8620H. Carborize to a hardness of 58-62 HRC with case depth (to 50HRC) of 0.75-1 [0.30-.040] (dimensions apply after heat treat).
2. Mating part to have critical dimensions as shown. Oil holes must be provided and open for proper oil circulation.
3. Some means of maintaining clearance between shaft and mounting flange must be provided
4. Seal to be furnished with motor for proper oil circulation thru splines
5. Counterbore designed to adapt to a standard sleeve bearing 35.040 [1.3784-1.3795] ID by 44.040-44.070 [1.7339-1.7350] O.D. (Oilite Bronze sleeve bearing AAM3544-22)

## SHAFT SEAL RATED PRESSURE

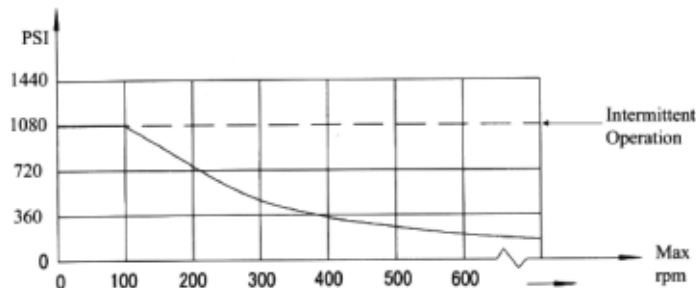
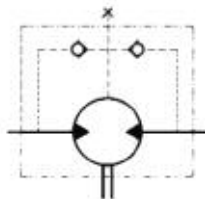

## CASE DRAIN

In applications without a motor drain line, the pressure exerted on the shaft seal is marginally in excess of the return line pressure. When the drain line is used the pressure exerted on the shaft seal is equal to the return line pressure.

## SHAFT ROTATION DIRECTION

STANDARD ROTATION VIEWED FROM SHAFT END

Port A pressurized = CW rotation  
 Port B pressurized = CCW rotation

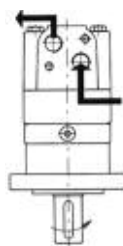

## RADIAL FORCES

Curve "A" shows max radial shaft load. Any shaft loads exceeding these values quoted in the curve will involve risk of breakage. The two other curves apply to a B10 bearing life of 3000 hours at 200 RPM.

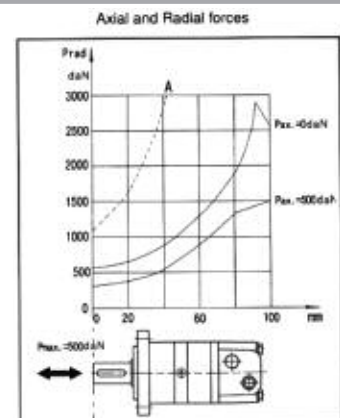

# HIGH TORQUE, LOW SPEED MOTORS

1-800-842-5377

## 2000 SERIES TECHNICAL DATA

2000 SERIES 80		80.6 Cm <sup>3</sup> /Rev 4.92 in <sup>3</sup> /Rev					Max Cont.	Max Int.
Pressure Bar (psi)		35 (515)	70 (1030)	105 (1546)	140 (2060)	175 (2576)	210 (3090)	225 (3308)
F L O W	LPM (GPM)	Torque Nm (in.Lbs) Speed Specification						
	15 (3.95)	35 (310)	80 (708)	120 (1062)	158 (1398)	195 (1726)	235 (2080)	249 (2204)
		180 rpm	174 rpm	168 rpm	164 rpm	158 rpm	151 rpm	143 rpm
	30 (7.90)	35 (310)	80 (708)	120 (1062)	158 (1398)	195 (1726)	240 (2124)	260 (2301)
		362 rpm	352 rpm	346 rpm	338 rpm	330 rpm	322 rpm	310 rpm
	40 (10.50)	35 (310)	79 (699)	119 (1053)	155 (1372)	193 (1708)	234 (2071)	250 (2213)
		482 rpm	473 rpm	464 rpm	453 rpm	444 rpm	434 rpm	415 rpm
	50 (13.20)	30 (266)	77 (681)	117 (1035)	153 (1354)	192 (1699)	232 (2053)	248 (2195)
		602 rpm	594 rpm	587 rpm	569 rpm	560 rpm	551 rpm	522 rpm
	60 (15.85)	28 (248)	77 (681)	117 (1035)	153 (1354)	192 (1699)	232 (2053)	247 (2186)
	724 rpm	713 rpm	707 rpm	683 rpm	673 rpm	664 rpm	629 rpm	
Max Cont.	75 (19.75)	25 (221)	75 (664)	114 (1009)	152 (1345)	190 (1682)	230 (2036)	245 (2168)
	840 rpm	832 rpm	817 rpm	796 rpm	786 rpm	777 rpm	737 rpm	
Max Int.	90 (23.85)	24 (217)	73 (646)	110 (974)	150 (1328)	185 (1637)	225 (1991)	240 (2124)
	900 rpm	893 rpm	872 rpm	853 rpm	843 rpm	834 rpm	792 rpm	

2000 SERIES 100		100.8 Cm <sup>3</sup> /Rev 6.15 in <sup>3</sup> /Rev					Max Cont.	Max Int.
Pressure Bar (psi)		35 (515)	70 (1030)	105 (1546)	140 (2060)	175 (2576)	210 (3090)	225 (3308)
F L O W	LPM (GPM)	Torque Nm (in.Lbs) Speed Specification						
	15 (3.95)	48 (425)	95 (841)	150 (1328)	200 (1770)	250 (2213)	289 (2558)	310 (2744)
		146 rpm	144 rpm	139 rpm	135 rpm	130 rpm	120 rpm	105 rpm
	30 (7.90)	45 (398)	94 (832)	146 (1292)	198 (1752)	250 (2213)	295 (2611)	317 (2805)
		291 rpm	289 rpm	278 rpm	274 rpm	269 rpm	258 rpm	242 rpm
	40 (10.50)	43 (381)	89 (788)	142 (1492)	196 (1735)	248 (2195)	293 (2593)	316 (2797)
		387 rpm	384 rpm	374 rpm	359 rpm	350 rpm	335 rpm	320 rpm
	50 (13.20)	40 (354)	88 (779)	135 (1195)	194 (1717)	247 (2186)	292 (2584)	315 (2788)
		486 rpm	483 rpm	473 rpm	462 rpm	450 rpm	430 rpm	420 rpm
	60 (15.85)	37 (327)	88 (779)	132 (1168)	185 (1657)	244 (2159)	289 (2558)	312 (2761)
	588 rpm	584 rpm	574 rpm	562 rpm	550 rpm	538 rpm	520 rpm	
Max Cont.	75 (19.75)	35 (310)	80 (708)	130 (1151)	180 (1593)	240 (2124)	286 (2531)	310 (2744)
	740 rpm	735 rpm	720 rpm	705 rpm	696 rpm	676 rpm	653 rpm	
Max Int.	90 (23.85)	30 (266)	75 (664)	124 (1097)	170 (1505)	236 (2089)	277 (24510)	303 (2682)
	850 rpm	840 rpm	810 rpm	787 rpm	770 rpm	750 rpm	747 rpm	

2000 SERIES 125		125 Cm <sup>3</sup> /Rev 7.65 in <sup>3</sup> /Rev					Max Cont.	Max Int.
Pressure Bar (psi)		35 (515)	70 (1030)	105 (1546)	140 (2060)	175 (2576)	210 (3090)	225 (3308)
F L O W	LPM (GPM)	Torque Nm (in.Lbs) Speed Specification						
	15 (3.95)	55 (487)	120 (1062)	176 (1558)	245 (2168)	309 (2735)	349 (3089)	375 (3319)
		112 rpm	110 rpm	103 rpm	96 rpm	93 rpm	90 rpm	84 rpm
	30 (7.90)	55 (487)	120 (1062)	175 (1549)	250 (2213)	324 (2867)	375 (3319)	408 (3611)
		222 rpm	220 rpm	217 rpm	208 rpm	200 rpm	199 rpm	190 rpm
	40 (10.50)	55 (487)	120 (1062)	175 (1549)	250 (2213)	324 (2867)	370 (3275)	408 (3611)
		302 rpm	298 rpm	292 rpm	284 rpm	276 rpm	268 rpm	260 rpm
	50 (13.20)	50 (443)	115 (443)	176 (1558)	248 (2195)	320 (3832)	370 (3275)	406 (3593)
		379 rpm	373 rpm	368 rpm	363 rpm	350 rpm	339 rpm	328 rpm
	60 (15.85)	45 (398)	113 (1000)	171 (1513)	245 (2168)	324 (2867)	368 (3257)	406 (3593)
	456 rpm	448 rpm	443 rpm	439 rpm	425 rpm	406 rpm	393 rpm	
Max Cont.	75 (19.75)	45 (398)	110 (974)	167 (1478)	240 (2724)	314 (2779)	370 (3275)	401 (3549)
	570 rpm	563 rpm	555 rpm	546 rpm	533 rpm	515 rpm	503 rpm	
Max Int.	90 (23.85)	40 (354)	105 (938)	162 (1434)	237 (2097)	309 (2735)	365 (3230)	398 (3522)
	685 rpm	676 rpm	670 rpm	659 rpm	644 rpm	625 rpm	610 rpm	

## 2000 SERIES TECHNICAL DATA

2000 SERIES 160		154 Cm <sup>3</sup> /Rev 9.39 in <sup>3</sup> /Rev					Max Cont.	Max Int.
Pressure Bar (psi)		35 (515)	70 (1030)	105 (1546)	140 (2060)	175 (2576)	210 (3090)	225 (3308)
F L O W	LPM (GPM)	Torque Nm (in.Lbs) Speed Specification						
	15 (3.95)	70 (620)	142 (1257)	215 (1904)	298 (2639)	372 (3295)	435 (3852)	476 (4216)
		93 rpm	91 rpm	89 rpm	85 rpm	80 rpm	76 rpm	58 rpm
	30 (7.90)	73 (646)	151 (1337)	225 (1992)	312 (2763)	382 (3383)	456 (4038)	492 (4357)
		189 rpm	187 rpm	181 rpm	176 rpm	170 rpm	162 rpm	153 rpm
	40 (10.50)	75 (664)	152 (1346)	228 (2019)	314 (2781)	383 (3392)	454 (4021)	488 (4322)
		252 rpm	250 rpm	246 rpm	239 rpm	234 rpm	228 rpm	212 rpm
	50 (13.20)	70 (620)	148 (1310)	225 (1992)	305 (2701)	372 (3294)	445 (3941)	480 (4251)
		313 rpm	310 rpm	306 rpm	298 rpm	293 rpm	285 rpm	272 rpm
	60 (15.85)	68 (575)	143 (1266)	218 (1930)	296 (2621)	370 (3277)	442 (3914)	480 (4251)
	378 rpm	376 rpm	370 rpm	362 rpm	353 rpm	346 rpm	332 rpm	
Max Cont.	75 (19.75)	62 (549)	140 (1239)	211 (1868)	291 (2577)	365 (3232)	439 (3888)	475 (4207)
	475 rpm	469 rpm	461 rpm	450 rpm	441 rpm	432 rpm	414 rpm	
Max Int.	90 (23.85)	59 (522)	131 (1160)	202 (1789)	286 (2533)	337 (2984)	425 (3764)	460 (4074)
	567 rpm	561 rpm	554 rpm	543 rpm	532 rpm	520 rpm	509 rpm	

2000 SERIES 200		200 Cm <sup>3</sup> /Rev 12.2 in <sup>3</sup> /Rev					Max Cont.	Max Int.
Pressure Bar (psi)		35 (515)	70 (1030)	105 (1546)	140 (2060)	175 (2576)	210 (3090)	225 (3308)
F L O W	LPM (GPM)	Torque Nm (in.Lbs) Speed Specification						
	15 (3.95)	87 (771)	179 (1585)	273 (2737)	371 (3286)	471 (4171)	562 (4977)	610 (5403)
		74 rpm	73 rpm	71 rpm	68 rpm	64 rpm	60 rpm	48 rpm
	30 (7.90)	91 (806)	190 (1682)	288 (2550)	386 (3418)	489 (4331)	572 (5066)	618 (5473)
		150 rpm	148 rpm	143 rpm	140 rpm	134 rpm	128 rpm	119 rpm
	40 (10.50)	94 (832)	193 (1709)	296 (2621)	394 (3489)	498 (4410)	584 (5172)	645 (5712)
		198 rpm	195 rpm	192 rpm	188 rpm	183 rpm	178 rpm	167 rpm
	50 (13.20)	90 (797)	191 (1691)	292 (2586)	389 (3445)	493 (4366)	580 (5137)	634 (5615)
		248 rpm	246 rpm	241 rpm	236 rpm	230 rpm	223 rpm	212 rpm
	60 (15.85)	85 (752)	185 (1638)	279 (2471)	382 (3383)	483 (4277)	575 (5092)	622 (5509)
	300 rpm	295 rpm	288 rpm	281 rpm	273 rpm	263 rpm	251 rpm	
Max Cont.	75 (19.75)	78 (690)	176 (1558)	271 (2400)	370 (3277)	472 (4180)	561 (4968)	610 (5402)
	374 rpm	370 rpm	364 rpm	360 rpm	352 rpm	340 rpm	331 rpm	
Max Int.	90 (23.85)	68 (602)	163 (1443)	265 (2347)	361 (3197)	456 (4038)	545 (4827)	599 (5305)
	443 rpm	440 rpm	435 rpm	428 rpm	424 rpm	413 rpm	400 rpm	

2000 SERIES 250		243 Cm <sup>3</sup> /Rev 14.8 in <sup>3</sup> /Rev					Max Cont.	Max Int.
Pressure Bar (psi)		35 (515)	70 (1030)	105 (1546)	140 (2060)	175 (2576)	210 (3090)	225 (3308)
F L O W	LPM (GPM)	Torque Nm (in.Lbs) Speed Specification						
	15 (3.95)	110 (974)	231 (2045)	351 (3108)	462 (4091)	585 (5181)	681 (6031)	778 (6890)
		59 rpm	58 rpm	56 rpm	53 rpm	50 rpm	46 rpm	35 rpm
	30 (7.90)	116 (1027)	236 (2090)	359 (3179)	475 (4207)	597 (5287)	700 (6199)	790 (6997)
		119 rpm	117 rpm	114 rpm	108 rpm	102 rpm	92 rpm	80 rpm
	40 (10.50)	118 (1045)	241 (2134)	363 (3215)	480 (4251)	599 (5305)	706 (6253)	796 (7050)
		162 rpm	159 rpm	156 rpm	150 rpm	143 rpm	134 rpm	121 rpm
	50 (13.20)	111 (983)	234 (2072)	352 (3117)	472 (4180)	591 (5234)	693 (6137)	788 (6979)
		203 rpm	201 rpm	197 rpm	191 rpm	182 rpm	173 rpm	158 rpm
	60 (15.85)	106 (929)	224 (1947)	345 (3055)	462 (4091)	582 (5154)	685 (6067)	772 (6837)
	244 rpm	242 rpm	237 rpm	230 rpm	220 rpm	208 rpm	194 rpm	
Max Cont.	75 (19.75)	101 (841)	214 (1895)	340 (3011)	454 (4021)	570 (5048)	670 (5934)	760 (6731)
	303 rpm	299 rpm	294 rpm	285 rpm	272 rpm	260 rpm	244 rpm	
Max Int.	90 (23.85)	93 (797)	209 (1851)	335 (2967)	447 (3959)	559 (4951)	657 (5819)	749 (6633)
	363 rpm	359 rpm	354 rpm	348 rpm	340 rpm	328 rpm	303 rpm	

# HIGH TORQUE, LOW SPEED MOTORS

1-800-842-5377

## 2000 SERIES TECHNICAL DATA

2000 SERIES 315		311 Cm <sup>3</sup> /Rev 18.9 in <sup>3</sup> /Rev					Max Cont.	Max Int.
Pressure Bar (psi)		35 (515)	70 (1030)	105 (1546)	140 (2060)	175 (2576)	210 (3090)	225 (3308)
F L O W	LPM (GPM)	Torque Nm (in.Lbs) Speed Specification						
	15 (3.95)	148 (1310)	304 (2692)	456 (4038)	613 (5429)	762 (6749)	879 (7785)	978 (8662)
		48 rpm	47 rpm	45 rpm	43 rpm	41 rpm	39 rpm	27 rpm
	30 (7.90)	155 (1372)	314 (2781)	465 (4118)	635 (5624)	778 (6890)	884 (7829)	988 (8750)
		95 rpm	93 rpm	91 rpm	89 rpm	86 rpm	82 rpm	67 rpm
	40 (10.50)	160 (1417)	321 (2843)	479 (4242)	650 (5757)	796 (7050)	906 (8024)	997 (8830)
		127 rpm	125 rpm	121 rpm	117 rpm	115 rpm	109 rpm	91 rpm
	50 (13.20)	155 (1372)	314 (2781)	465 (4118)	638 (5650)	780 (6908)	886 (7847)	988 (8750)
		159 rpm	157 rpm	153 rpm	149 rpm	145 rpm	142 rpm	128 rpm
	60 (15.85)	151 (1337)	306 (2710)	453 (4012)	620 (5491)	756 (6695)	886 (7847)	976 (8644)
	187 rpm	185 rpm	181 rpm	176 rpm	169 rpm	157 rpm	143 rpm	
Max Cont.	75 (19.75)	146 (1293)	300 (2657)	445 (3941)	613 (5429)	755 (6681)	755 (7743)	966 (8549)
		238 rpm	236 rpm	232 rpm	227 rpm	224 rpm	220 rpm	196 rpm
Max Int.	90 (23.85)	135 (1194)	284 (2513)	436 (3858)	601 (5318)	740 (6549)	863 (7637)	952 (8425)
		286 rpm	283 rpm	278 rpm	272 rpm	265 rpm	257 rpm	232 rpm

2000 SERIES 400		394 Cm <sup>3</sup> /Rev 24 in <sup>3</sup> /Rev				Max Cont.	Max Int.
Pressure Bar (psi)		35 (515)	70 (1030)	105 (1546)	140 (2060)	160 (2354)	175 (2576)
F L O W	LPM (GPM)	Torque Nm (in.Lbs) Speed Specification					
	15 (3.95)	186 (1646)	379 (3354)	578 (5115)	779 (6894)	896 (5204)	986 (8726)
		37 rpm	36 rpm	35 rpm	33 rpm	31 rpm	29 rpm
	30 (7.90)	190 (1681)	388 (3433)	590 (5221)	791 (7000)	905 (8009)	991 (8770)
		75 rpm	73 rpm	71 rpm	68 rpm	65 rpm	61 rpm
	40 (10.50)	195 (1725)	394 (3486)	569 (5035)	797 (7053)	912 (8071)	998 (8832)
		99 rpm	97 rpm	95 rpm	93 rpm	90 rpm	85 rpm
	50 (13.20)	191 (1690)	388 (3433)	587 (5194)	785 (6947)	904 (8000)	983 (8699)
		125 rpm	123 rpm	118 rpm	114 rpm	109 rpm	102 rpm
	60 (15.85)	186 (1646)	388 (3433)	587 (5194)	785 (6947)	904 (8000)	983 (8699)
	149 rpm	146 rpm	142 rpm	137 rpm	131 rpm	122 rpm	
Max Cont.	75 (19.75)	181 (1601)	372 (3292)	576 (5097)	770 (6814)	891 (7885)	973 (8611)
		187 rpm	183 rpm	177 rpm	171 rpm	164 rpm	153 rpm
Max Int.	90 (23.85)	176 (1557)	367 (3247)	571 (5053)	766 (6779)	883 (7814)	965 (8540)
		226 rpm	221 rpm	214 rpm	208 rpm	199 rpm	183 rpm

2000 SERIES 475		475 Cm <sup>3</sup> /Rev 28.9 in <sup>3</sup> /Rev			Max Cont.	Max Int.
Pressure Bar (psi)		35 (515)	70 (1030)	105 (1546)	140 (2060)	150 (2207)
F L O W	LPM (GPM)	Torque Nm (in.Lbs) Speed Specification				
	15 (3.95)	218 (1929)	439 (3885)	661 (5849)	892 (7894)	995 (8805)
		30 rpm	29 rpm	28 rpm	27 rpm	25 rpm
	30 (7.90)	223 (1973)	450 (3982)	676 (5982)	910 (8053)	1002 (8867)
		61 rpm	60 rpm	58 rpm	56 rpm	53 rpm
	40 (10.50)	228 (2017)	461 (4079)	689 (6097)	927 (8203)	1017 (9000)
		82 rpm	80 rpm	77 rpm	74 rpm	68 rpm
	50 (13.20)	224 (1982)	456 (4035)	682 (6035)	920 (8142)	1008 (8920)
		103 rpm	101 rpm	97 rpm	92 rpm	86 rpm
	60 (15.85)	220 (1947)	451 (3991)	677 (5991)	913 (8080)	998 (8832)
	123 rpm	121 rpm	118 rpm	112 rpm	105 rpm	
Max Cont.	75 (19.75)	212 (1876)	443 (3920)	664 (5876)	901 (7973)	980 (8673)
		155 rpm	153 rpm	147 rpm	140 rpm	132 rpm
Max Int.	90 (23.85)	196 (1734)	421 (3725)	643 (5690)	877 (7761)	959 (8487)
		186 rpm	184 rpm	178 rpm	170 rpm	157 rpm

# HIGH TORQUE, LOW SPEED MOTORS

## 6000-SERIES

The 6000 series motor is a large volume, disc valve, high pressure motor, with a radial ball-bearing design. They are capable of handling greater loads and higher torque applications. The advance design in disc distribution flow provides improved performance at low speed. The disc valve compensates for wear providing volumetric efficiencies. The double taper roller bearings allow for high radial loads making these motors ideal for heavier vehicles in traction drive applications.

These low weight advanced construction design motors are manufactured in accordance with the requirements of the ISO 9001:2000 quality system.

### Technical Specifications

			FLUIDYNE 112 6000 SERIES								
			Fluidyne	195 cm <sup>3</sup> (11.9)	245 cm <sup>3</sup> (15)	310 cm <sup>3</sup> (19)	395 cm <sup>3</sup> (24.2)	490 cm <sup>3</sup> (30)	625 cm <sup>3</sup> (38)	800 cm <sup>3</sup> (49)	965 cm <sup>3</sup> (60)
			Char-Lynn reference	195 cm <sup>3</sup> (11.9)	245 cm <sup>3</sup> (15)	310 cm <sup>3</sup> (19)	390 cm <sup>3</sup> (23.9)	490 cm <sup>3</sup> (30)	625 cm <sup>3</sup> (38)	800 cm <sup>3</sup> (49)	965 cm <sup>3</sup> (60)
MOUNTING	Shafts	PORTS									
4 BOLT STD SAE CC FLANGE	1 1/2" STRAIGHT KEY	1 5/16" -12 O-RING	WF1121064	WF1121065	WF1121066	WF1121067	WF1121068	WF1121107	-	WF1121066	
	40 mm STRAIGHT KEY	G 1 (BSP) O-RING	WF1121094	WF1121095	WF1121096	WF1121097	WF1121098	WF1121111	-	WF112-1099	
	1 1/2" 17 TOOTH SPLINE	1 5/16" -12 O-RING	WF1121058	WF1121059	WF1121060	WF1121061	WF1121062	WF1121109	-	WF1121063	
		G 1 (BSP) O-RING	WF1121088	WF1121089	WF1121090	WF1121091	WF1121092	-	-	WF1121083	
4 BOLT STD GLOBAL (ISO) MOUNT	1 3/4" TAPERED	1 5/16" -12 O-RING	WF1121052	WF1121053	WF1121054	WF1121055	WF1121056	-	WF1121325	WF1121057	
	50 mm STRAIGHT KEY	G 1 (BSP) O-RING	-	-	WF1121217	WF1121218	WF1121215	WF1121216	WF1121219	WF1121220	
WHEEL MOTOR	1 3/4" TAPERED	1 5/16" -12 O-RING	-	-	WF1121282	WF1121248	WF1121212	WF1121230	WF1121231	WF1121237	
	40 mm STRAIGHT KEY	1 5/16" -12 O-RING	WF1131082	WF1131083	WF1131084	WF1131085	WF1131086	WF1131100	-	WF1131087	
BEARINGLESS	G 1 (BSP)	1 5/16" O-RING	WF1131070	WF1131071	WF1131072	WF1131073	WF1131074	WF1131093	-	WF1131075	
		WF1141043	WF1141044	WF1141045	WF1141046	WF1141047	-	-	WF1141048		
Max Torque (in-lbs)	Continuous		5,088	6,594	8,232	10,344	10,752	11,772	12,216	13,896	
	Intermittent		7,608	10,440	11,820	14,652	16,680	12,216	14,604	16,596	
Max Pressure (PSI)	Continuous		3,000	3,000	3,000	3,000	2,500	2,000	1,800	1,800	
	Intermittent		4,500	4,500	4,500	4,500	4,000	2,500	2,000	2,000	
Max Flow (GPM)	Continuous		40	40	40	40	40	40	40	40	
	Intermittent		45	55	60	60	60	60	60	60	
Max RPM	Continuous		775	615	485	383	307	241	184	153	
	Intermittent		865	834	668	563	454	365	276	230	
Weight (LBS)	Weight		45	45	46	47	49	51	29	30	

Continuous = maximum of continuous operation

Intermittent = maximum operating range for 6 seconds per minute

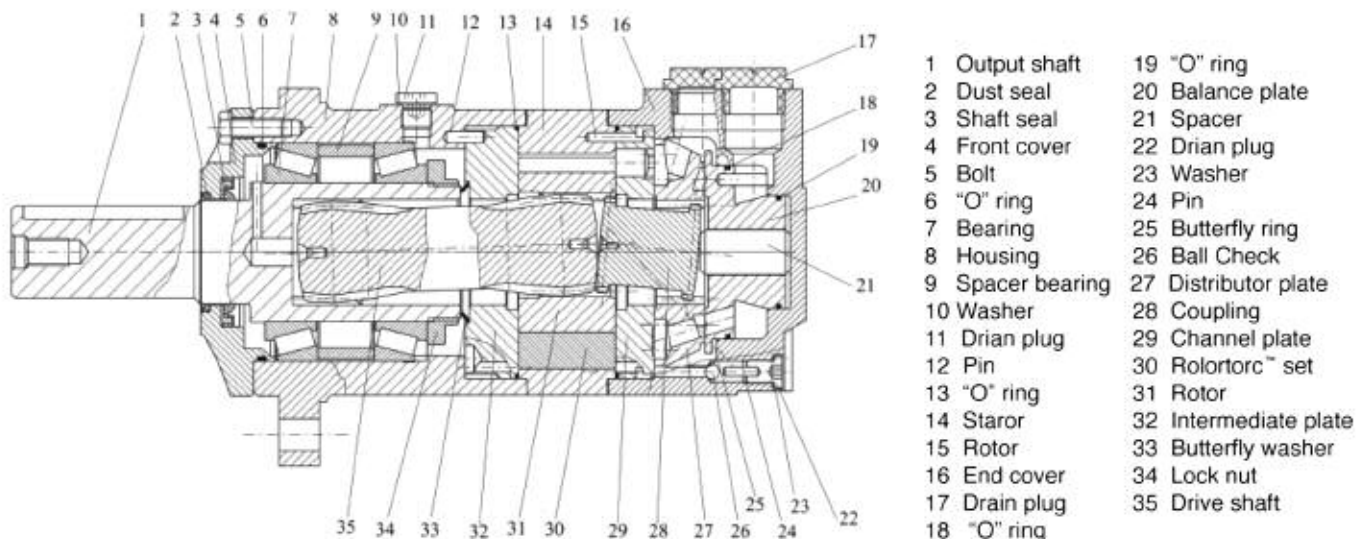

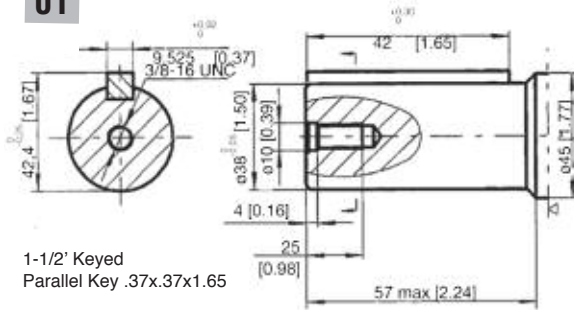

## 6000-SERIES SHAFT DATA

**01**

1-1/2" Keyed  
Parallel Key .37x.37x1.65

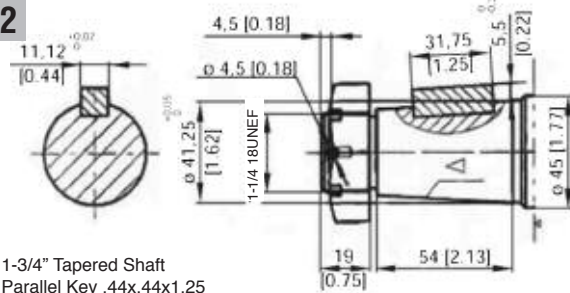
**02**

1-3/4" Tapered Shaft  
Parallel Key .44x.44x1.25  
Tightening torque: 500±10Nm

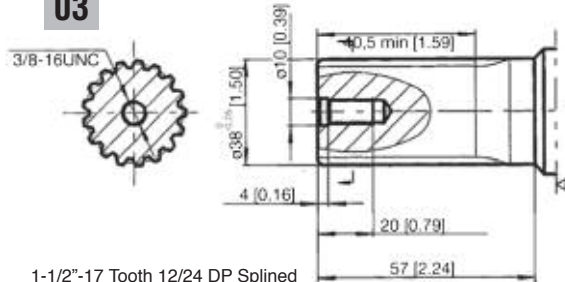
**03**

1-1/2"-17 Tooth 12/24 DP Splined

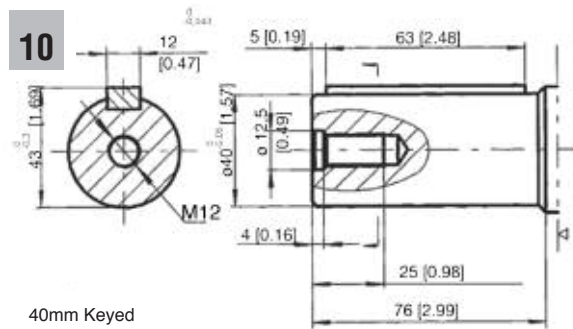
**10**

40mm Keyed  
Parallel Key 12x8x63

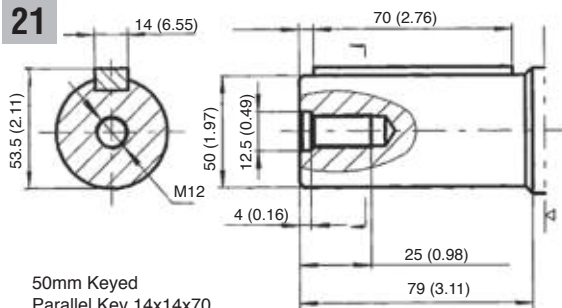
**21**

50mm Keyed  
Parallel Key 14x14x70

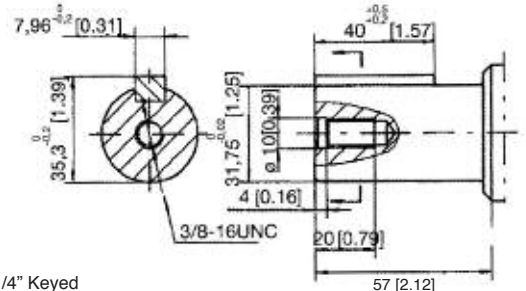
**41**

1-1/4" Keyed  
Parallel Key .31x.31x1.57

## MODEL CODE - 6000 SERIES

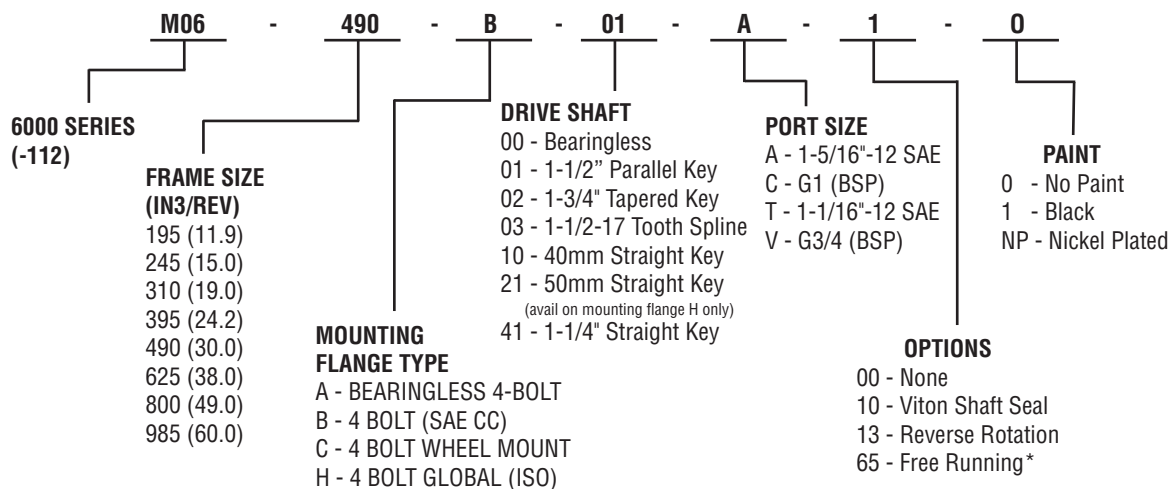

Additional flange and drive shaft options available please consult factory

\*Available on selected models

# HIGH TORQUE, LOW SPEED MOTORS

## 6000 SERIES INSTALLATION DATA

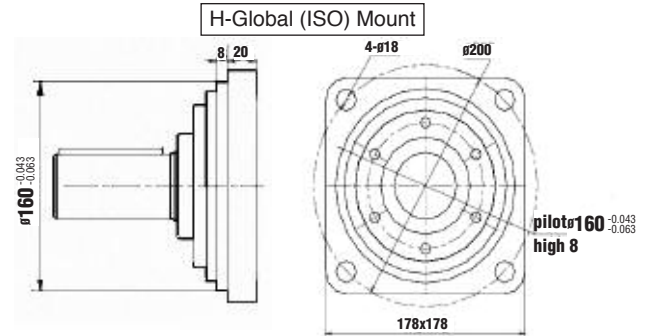
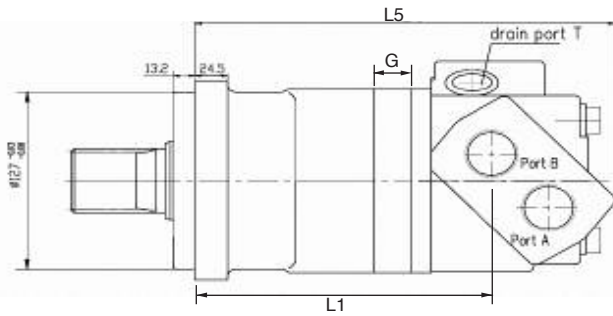

6000 - Series Installation Data									
Displacement - cm <sup>3</sup> /rev	Dimension cm (inch)								
	L5	266 (10.47)	271 (10.67)	278 (10.9)	288 (11.34)	298 (11.73)	313 (12.32)	333 (13.11)	352 (13.86)
L1	187.7 (7.39)	193.3 (7.6)	200.5 (7.89)	211 (8.31)	220.4 (8.68)	235 (9.25)	256 (10.08)	274.5 (10.81)	
G	21.7 (0.85)	27.3 (1.07)	34.5 (1.36)	45 (1.77)	54.4 (2.14)	68 (2.72)	90 (3.54)	108.5 (4.27)	

B-Std SAE CC Mount

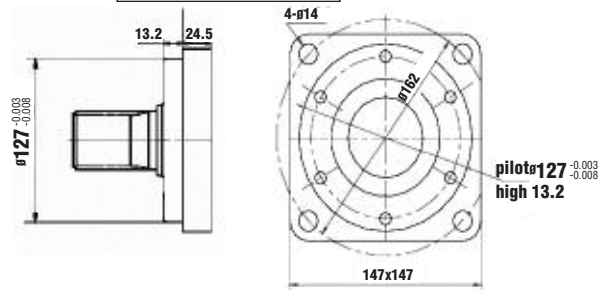

## BEARINGLESS MOTOR

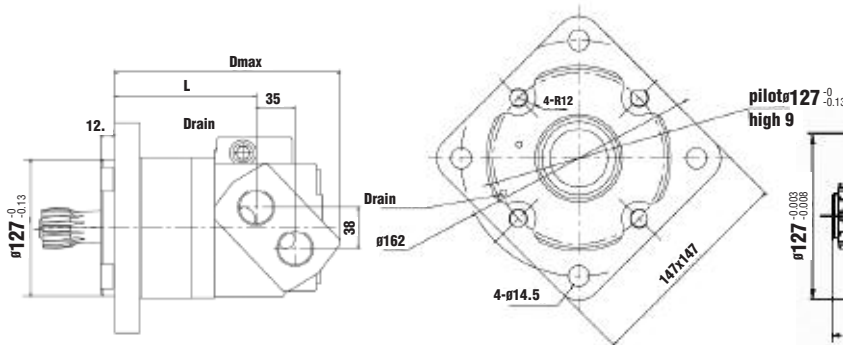

6000 Series - Bearingless Motor Dimensions									
Displacement - cm <sup>3</sup> /rev	Dimension cm (inch)								
	L	105 (4.1)	111 (4.37)	118 (4.65)	127 (5.0)	138 (5.43)	153 (6.02)	174 (6.85)	193 (7.6)
D <sub>max</sub>	188 (7.4)	194 (7.64)	200 (7.87)	210 (8.27)	221 (8.70)	235 (9.25)	256 (10.08)	275 (10.83)	

C-Wheel Mount

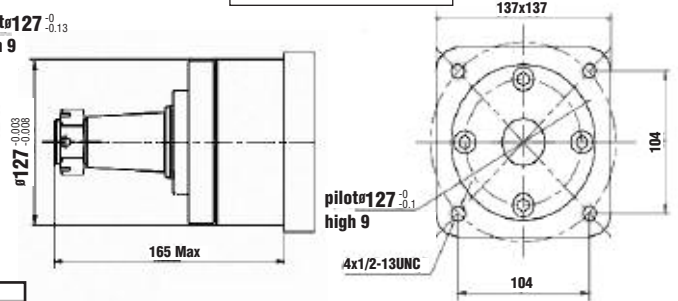

## SHAFT SEAL RATED PRESSURE

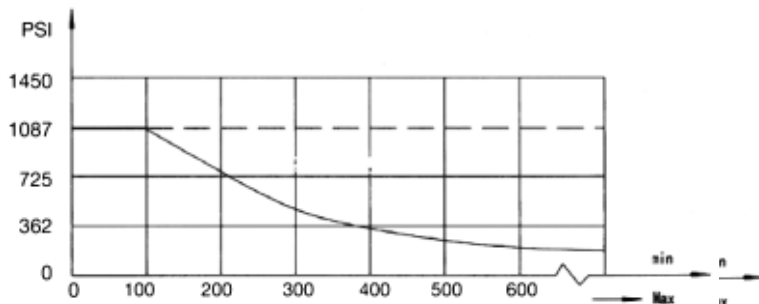
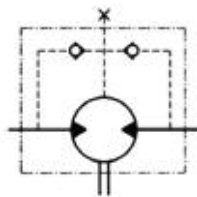

## CASE DRAIN

In applications without a motor drain line, the pressure exerted on the shaft seal is marginally in excess of the return line pressure. When the drain line is used the pressure exerted on the shaft seal is equal to the return line pressure.

## SHAFT ROTATION DIRECTION

STANDARD ROTATION VIEWED FROM SHAFT END

Port A pressurized = CW rotation  
Port B pressurized = CCW rotation

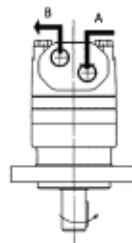

## RADIAL FORCES

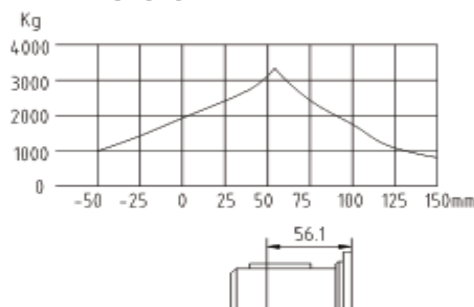

# HIGH TORQUE, LOW SPEED MOTORS

1-800-842-5377

## 6000 SERIES TECHNICAL DATA

6000 SERIES 195		195 Cm <sup>3</sup> /Rev 11.9 in <sup>3</sup> /Rev					Max Cont.	Max Int.			
Pressure	Bar (PSI)	35 (500)	70 (1000)	105 (1500)	140 (2000)	170 (2500)	205 (3000)	240 (3500)	275 (4000)	310 (4500)	
<b>FLOW</b>	LPM (GPM)	<b>Torque in Nm (in.Lbs) Speed specification</b>									
	15 (3.95) (rpm)	80 (708) 76	175 (1549) 74	271 (2399) 71	366 (3239) 65	454 (4018) 62	521 (4611) 45	589 (5213) 32	654 (5788) 18		
	30 (7.90) (rpm)	86 (761) 153	179 (1584) 148	274 (2425) 144	371 (3284) 130	464 (4107) 119	545 (4824) 116	626 (5541) 99	704 (6231) 82	779 (6895) 65	
	45 (12.0) (rpm)	85 (752) 230	180 (1593) 226	279 (2469) 221	374 (3310) 212	476 (4213) 202	565 (5000) 186	654 (5788) 168	751 (6647) 148	825 (7302) 118	
	61 (16.0) (rpm)	79 (699) 307	179 (1584) 303	280 (2478) 300	376 (3328) 290	475 (4204) 283	574 (5080) 258	664 (5877) 236	760 (6727) 214	845 (7479) 181	
	76 (20.0) (rpm)	80 (708) 385	179 (1584) 379	281 (2487) 373	380 (3363) 365	480 (4248) 255	574 (5080) 332	671 (5939) 305	769 (6806) 280	860 (7612) 246	
	91 (24.0) (rpm)	80 (708) 462	174 (1540) 456	274 (2425) 450	375 (3319) 439	474 (4195) 430	575 (5089) 412	669 (5921) 388	770 (6815) 363		
	106 (28.0) (rpm)	74 (655) 539	176 (1558) 532	271 (2399) 525	375 (3319) 513	474 (4195) 502	570 (5045) 475	669 (5921) 448	770 (6815) 420		
	121 (32.0) (rpm)	70 (620) 617	169 (1496) 609	269 (2381) 602	369 (3266) 590	470 (4160) 575	570 (5045) 541	670 (5930) 510	763 (6753) 480		
	136 (36.0) (rpm)	70 (620) 692	163 (1443) 684	264 (2337) 674	364 (3222) 660	465 (4116) 645	565 (5000) 600	664 (5877) 564	763 (6753) 527		
	151 (40.0) (rpm)	70 (620) 770	164 (1452) 759	261 (2310) 745	364 (3222) 733	466 (4124) 717	559 (4948) 666	660 (5841) 624			
	Max Cont.	170 (45.0) (rpm)	65 (575)	161 (1425)	259 (2292)	360 (3186)	461 (4080)	555 (4912)	655 (5797)		
	Max Int.	(rpm)	866	854	844	825	808	749	702		

6000 SERIES 245		245 Cm <sup>3</sup> /Rev 15.0 in <sup>3</sup> /Rev					Max Cont.	Max Int.			
Pressure	Bar (PSI)	35 (500)	70 (1000)	105 (1500)	140 (2000)	170 (2500)	205 (3000)	240 (3500)	275 (4000)	310 (4500)	
<b>FLOW</b>	LPM (GPM)	<b>Torque in Nm (in.Lbs) Speed specification</b>									
	15 (3.95) (rpm)	106 (938) 60	227 (2009) 56	346 (3062) 54	461 (4090) 48	577 (5107) 42	643 (5691) 39	751 (6647) 30	853 (7550) 12	960 (8497) 6	
	30 (7.90) (rpm)	110 (974) 120	237 (2098) 116	354 (3133) 113	475 (4204) 104	596 (5275) 95	701 (6204) 81	800 (7081) 67	905 (8010) 48	1018(9010) 35	
	45 (12.0) (rpm)	110 (974) 182	235 (2080) 179	360 (3186) 175	482 (4266) 165	607 (5372) 157	721 (6381) 141	840 (7435) 123	955 (8452) 107	1075(9515) 90	
	61 (16.0) (rpm)	112 (991) 244	236 (2089) 240	360 (3186) 236	487 (4310) 228	611 (5408) 221	730 (6461) 202	844 (7470) 184	960 (8497) 163	1181(10543) 144	
	76 (20.0) (rpm)	105 (929) 306	232 (2053) 301	354 (3133) 297	485 (4293) 287	614 (5434) 277	735 (6505) 256	853 (7550) 238	980 (8674) 217	1100(9736) 197	
	91 (24.0) (rpm)	104 (920) 365	231 (2045) 361	356 (3151) 357	482 (4266) 348	612 (5417) 338	735 (6505) 314	861 (7620) 290	979 (8665) 270		
	106 (28.0) (rpm)	102 (903) 426	227 (2009) 421	352 (3115) 416	483 (4275) 403	611 (5408) 375	733(6488) 355	855 (7567) 335	980 (8674) 320		
	121 (32.0) (rpm)	91 (805) 489	216 (1912) 481	346 (3062) 474	470 (4160) 461	600 (5310) 447	725 (6417) 422	840 (7435) 395	975 (8629) 370		
	136 (36.0) (rpm)	80 (708) 550	210 (1859) 544	334 (2956) 537	460 (4071) 524	580 (5133) 510	710 (6284) 490	840 (7435) 454			
	151 (40.0) (rpm)	80 (708) 612	202 (1788) 606	330 (2921) 600	456 (4036) 585	580 (5133) 570	700 (6196) 538	800 (7081) 507			
	Max Cont.	170 (45.0) (rpm)	66 (584)	202 (1788)	326 (2885)	446 (3947)	575 (5089)	685 (6063)	755 (6682)		
	Max Int.	189 (50.0) (rpm)	688	682	674	665	640	606	571		
		208 (55.0) (rpm)		195 (1726)	316 (2797)	441 (3903)	555 (4912)	670 (5930)			
				758	749	731	710	675			
				191 (1690)	311 (2753)	431 (3815)	551 (4877)	665 (5886)			
				834	824	804	783	742			

6000 SERIES 310		310 Cm <sup>3</sup> /Rev 19.0 in <sup>3</sup> /Rev					Max Cont.	Max Int.			
Pressure	Bar (PSI)	35 (500)	70 (1000)	105 (1500)	140 (2000)	170 (2500)	205 (3000)	240 (3500)	275 (4000)	310 (4500)	
<b>FLOW</b>	LPM (GPM)	<b>Torque in Nm (in.Lbs) Speed specification</b>									
	15 (3.95) (rpm)	136 (1204) 47	292 (2584) 45	431 (3815) 42	573 (5071) 38	684 (6054) 32	801 (7089) 24	934 (8267) 17	1020(9028) 10	1070 (9470) 3	
	30 (7.90) (rpm)	140 (1239) 95	300 (2655) 92	451 (3992) 87	596 (5275) 81	732 (6479) 73	870 (7700) 63	985 (8718) 54	1100(9736) 44	1235(10931) 32	
	45 (12.0) (rpm)	140 (1239) 143	306 (2708) 140	461 (4080) 135	612 (5417) 129	760 (6727) 120	909 (8045) 110	1045(9249) 99	1180(10444) 88	1330(11771) 75	
	61 (16.0) (rpm)	140 (1239) 192	302 (2673) 188	462 (4089) 184	615 (5443) 178	771 (6824) 167	920 (8143) 154	1060(9382) 140	1200(10621) 124	1350(11949) 109	
	76 (20.0) (rpm)	135 (1195) 241	296 (2620) 236	457 (4045) 232	617 (5461) 226	772 (6833) 216	925 (8187) 200	1075(9515) 182	1220(10798) 165		
	91 (24.0) (rpm)	130 (1151) 289	296 (2620) 282	456 (4036) 278	614 (5434) 273	774 (6850) 260	929 (8222) 248	1078(9541) 232	1226(10851) 215		
	106 (28.0) (rpm)	130 (1151) 336	290 (2567) 333	450 (3983) 327	609 (5390) 320	768 (6797) 308	928 (8213) 295	1073(9497) 276	1220(10798) 257		
	121 (32.0) (rpm)	125 (1106) 384	285 (2522) 381	444 (3930) 375	600 (5310) 367	763 (6753) 354	918 (8125) 341	1060(9382) 320			
	136 (36.0) (rpm)	120 (1062) 430	276 (2443) 421	434 (3841) 416	590 (5222) 410	748 (6620) 396	912 (8072) 383	1050(9293) 360			
	151 (40.0) (rpm)	115 (1018) 478	271 (2399) 466	424 (3753) 461	578 (5116) 456	743 (6576) 441	902 (7983) 427	1035(9161) 403			
	Max Cont.	189 (50.0) (rpm)	110 (974)	245 (2168)	364 (3399)	523 (4629)	682 (6036)	836 (7399)			
	Max Int.	227 (60.0) (rpm)	597	582	576	570	551	534			
				220 (1947)	364 (3222)	513 (4540)	647 (5726)	796 (7045)			
				698	691	684	661	641			

## 6000 SERIES TECHNICAL DATA

6000 SERIES 395		395 Cm <sup>3</sup> /Rev 24.17 in <sup>3</sup> /Rev				Max Cont.		Max Int.		
Pressure	Bar (PSI)	35 (500)	70 (1000)	105 (1500)	140 (2000)	170 (2500)	205 (3000)	240 (3500)	275 (4000)	310 (4500)
F L O W	LPM (GPM)	Torque in Nm (in.Lbs) Speed specification								
	15 (3.95) (rpm)	188 (1664) 37	378(3346) 36	563(4983) 34	743(6576) 32	923(8169) 28	1083(9585) 21	1276(11294) 13	1371(12134) 5	1635(14471) 1
	30 (7.90) (rpm)	188 (1664) 75	383(3390) 73	578(5116) 71	763(6753) 67	953(8435) 64	1137(10063) 54	1316(11648) 44	1456(12887) 32	1635(14471) 20
	45 (12.0) (rpm)	188 (1664) 114	388(3434) 111	583(5160) 108	773(6842) 104	968(8568) 99	1152(10196) 90	1341(11869) 80	1540(13630) 78	
	61 (16.0) (rpm)	183 (1620) 153	383(3390) 150	583(5160) 146	773(6842) 143	968(8568) 131	1156(10231) 125	1345(11904) 115		
	76 (20.0) (rpm)	183 (1620) 192	383(3390) 188	583(5160) 186	778(6886) 181	973(8612) 174	1161(10276) 161	1356(12002) 151		
	91 (24.0) (rpm)	173 (1531) 228	373(3301) 228	573(5071) 224	768(6797) 219	968(8568) 211	1156(10231) 203			
	106 (28.0) (rpm)	168 (1487) 267	368(3257) 265	568(5027) 260	763(6753) 254	963(8523) 247	1151(10187) 235			
	121 (32.0) (rpm)	163 (1443) 305	358(3169) 303	558(4939) 298	753(6665) 291	947(8382) 281	1146(10143) 268			
	136 (36.0) (rpm)	158 (1398) 345	343(3036) 339	548(4850) 335	733(6488) 328	933(8488) 316	1131(10010) 300			
	151 (40.0) (rpm)	153 (1354) 385	328(2903) 379	538(4762) 374	733(6488) 367	917(8116) 358				
	Max Cont.	189 (50.0) (rpm)	133 (1177) 481	303(2682) 474	518(4585) 468	733(6488) 459	913(8081) 448			
	Max Int.	227 (60.0) (rpm)		283(2505) 569	502(4443) 561	721(6381) 551	891(7896) 537			

6000 SERIES 490		490 Cm <sup>3</sup> /Rev 30.0 in <sup>3</sup> /Rev				Max Cont.		Max Int.		
Pressure	Bar (PSI)	35 (500)	70 (1000)	105 (1500)	140 (2000)	170 (2500)	205 (3000)	240 (3500)	275 (4000)	
F L O W	LPM (GPM)	Torque in Nm (in.Lbs) Speed specification								
	15 (3.95) (rpm)	235(2080) 30	468(4301) 29	725(6417) 28	962(8514) 27	1195(10577) 25	1408(12462) 21	1643(14542) 17	1880(16639) 12	
	30 (7.90) (rpm)	235(2080) 60	468(4301) 59	734(6496) 57	973(8612) 54	1213(10736) 51	1442(12763) 45	1680(14869) 38		
	45 (12.0) (rpm)	235(2080) 91	467(4133) 89	733(6488) 87	974(8621) 84	1218(10780) 79	1450(12834) 71			
	61 (16.0) (rpm)	234(2071) 122	480(4248) 121	728(6443) 118	973(8612) 114	1217(10771) 109	1456(12887) 100			
	76 (20.0) (rpm)	225(1991) 152	470(4160) 150	723(6399) 147	972(8603) 144	1217(10771) 139				
	91 (24.0) (rpm)	220(1947) 184	469(4151) 181	719(6364) 180	968(8568) 176	1210(10709) 171				
	106 (28.0) (rpm)	209(1850) 214	459(4062) 211	708(6266) 208	957(8470) 204	1205(10665) 198				
	121 (32.0) (rpm)	194(1717) 244	448(3965) 241	700(6196) 237	947(8382) 232	1200(10620) 226				
	136 (36.0) (rpm)	175(1549) 275	433(3832) 272	683(6045) 265	937(8293) 260	1170(10355) 255				
	151 (40.0) (rpm)	160(1416) 306	423(3744) 303	673(5957) 295	917(8116) 290	1145(10134) 284				
	Max Cont.	189 (50.0) (rpm)	130(1151) 382	364(3222) 379	588(5204) 365	857(7585) 362				
	Max Int.	227 (60.0) (rpm)		323(2859) 454	546(4833) 442	800(7081) 435				

6000 SERIES 625		625 Cm <sup>3</sup> /Rev 38.0 in <sup>3</sup> /Rev				Max Cont.		Max Int.		
Pressure	Bar (PSI)	35 (500)	50 (715)	70 (1015)	85 (1232)	105 (1522)	120 (1740)	140 (2030)	275 (4000)	
F L O W	LPM (GPM)	Torque in Nm (in.Lbs) Speed specification								
	15 (3.95) (rpm)	275 (2434) 24	425 (3762) 24	570 (5045) 23	709 (6275) 22	849 (7514) 21	954 (8444) 18	1063 (9408) 16	1190 (10532) 15	
	30 (7.90) (rpm)	295 (2611) 45	450 (3983) 44	604 (5346) 44	754 (6673) 43	923 (8169) 42	1093 (9674) 39	1267 (11214) 37	1355 (11992) 36	
	45 (12.0) (rpm)	295 (2611) 72	448 (3965) 71	609 (5390) 71	764 (6712) 70	918 (8125) 68	1123 (9939) 66	1327 (11745) 64	1375 (12170) 63	
	61 (16.0) (rpm)	285 (2522) 94	445 (3938) 93	604 (5346) 92	759 (6718) 91	914 (8089) 89	1118 (9895) 87	1324 (11718) 85	1370 (12126) 83	
	76 (20.0) (rpm)	280 (2478) 119	439 (3885) 118	594 (5257) 117	754 (6673) 116	914 (8089) 115	1118 (9895) 112	1323 (11709) 110	1372 (12143) 107	
	91 (24.0) (rpm)	264 (2337) 143	429 (3797) 142	585 (5178) 140	744 (6585) 139	904 (8001) 138	1108 (9806) 135	1317 (11658) 132	1365 (12081) 130	
	106 (28.0) (rpm)	255 (2257) 168	414 (3664) 166	574 (5080) 165	734 (6496) 164	893 (7904) 162	1103 (9762) 159	1312 (11612) 156	1360 (1203) 153	
	121 (32.0) (rpm)	240 (2124) 192	400 (3540) 190	559 (4948) 188	719 (6364) 187	878 (7771) 185	1088 (9630) 182	1297 (11479) 179	1345 (11904) 178	
	136 (36.0) (rpm)	220 (1947) 216	379 (3354) 214	539 (4771) 213	698 (6178) 212	853 (7550) 210	1047 (9266) 207			
	151 (40.0) (rpm)	200 (1770) 240	360 (3186) 239	519 (4594) 238	679 (6010) 237	833 (7373) 236	1012 (8957) 233			
	Max Cont.	189 (50.0) (rpm)		310 (2744) 298	469 (4151) 296	629 (5567) 294	788 (6974) 290			
	Max Int.	227 (60.0) (rpm)		254 (2248) 355	430 (3805) 353	588 (5204) 350	742 (6567) 345			

# HIGH TORQUE, LOW SPEED MOTORS

## 6000 SERIES TECHNICAL DATA

6000 SERIES 800		800 Cm <sup>3</sup> /Rev 49.0 in <sup>3</sup> /Rev					Max Cont.	Max Int.	
Pressure	Bar (PSI)	35 (500)	50 (715)	70 (1015)	85 (1232)	105 (1522)	120 (1740)	140 (2030)	
<b>F L O W</b>	LPM (GPM)	<b>Torque in Nm (in.Lbs) Speed specification</b>							
	15 (3.95) (rpm)	434 (3841) 18	607 (5372) 17	838 (7417) 17	1018 (9010) 16	1238(10957) 15	1337(12188) 14	1646(12568) 13	
	30 (7.90) (rpm)	419 (3708) 36	395 (3496) 35	828 (7328) 35	1003 (8877) 34	1238(10957) 33	1412(12497) 31	1606(14214) 25	
	45 (12.0) (rpm)	379 (3354) 55	564 (4991) 55	794 (7028) 54	970 (8585) 54	1187(10506) 53	1358(12019) 51		
	61 (16.0) (rpm)	339 (3000) 75	519 4594) 74	758 (6709) 72	937 (8293) 71	1167(10329) 70			
	76 (20.0) (rpm)	324 (2868) 93	498 (4408) 92	728 (6443) 90	897 (7939) 89	1135(10046) 87			
	91 (24.0) (rpm)	314 (2779) 111	468 (4142) 110	698 (5293) 109	857 (7585) 108	1076 (9523) 105			
	106 (28.0) (rpm)	309 (2735) 129	448 (3965) 128	648 (5735) 127	797 (7054) 125	1016 (8992) 123			
	121 (32.0) (rpm)	279 (2469) 148	419 (3708) 146	608 (5381) 145	746 (6603) 143				
	136 (36.0) (rpm)	269 (2381) 166	398 (3523) 165	547 (4841) 165	695 (6151) 164				
	151 (40.0) (rpm)	249 (2204) 191	348 (3080) 183	497 (4310) 182	631 (5585) 180				
	Max Cont.	189 (50.0) (rpm)	299 (2646) 230	438 (3877) 228	576 (5098) 225				
	Max Int.	227 (60.0) (rpm)		378 (3346) 276	516 (4567) 273				

6000 SERIES 985		985 Cm <sup>3</sup> /Rev 60.0 in <sup>3</sup> /Rev					Max Cont.	Max Int.	
Pressure	Bar (PSI)	35 (500)	50 (715)	70 (1015)	85 (1232)	105 (1522)	120 (1740)	140 (2030)	
<b>F L O W</b>	LPM (GPM)	<b>Torque in Nm (in.Lbs) Speed specification</b>							
	15 (3.95) (rpm)	484 (4284) 15	774 (6850) 15	964 (8532) 14	1203(10647) 14	1443(12772) 13	1567(13869) 13	1786(15807) 13	
	30 (7.90) (rpm)	494 (4372) 30	749 (6629) 30	994 (8798) 29	1233(10913) 28	1477(13073) 27	1637(14489) 26	1871(16560) 25	
	45 (12.0) (rpm)	494 (4372) 45	749 (6629) 45	1000(8850) 221	1258(11046) 43	1492(13205) 42	1696(15011) 41		
	61 (16.0) (rpm)	489 (4328) 61	739 (6541) 61	995 (8806) 60	1243(11001) 59	1497(13250) 58			
	76 (20.0) (rpm)	475 (4204) 77	730 (6461) 379	983 (8700) 76	1233(10913) 75	1481(13108) 74			
	91 (24.0) (rpm)	460 (4071) 92	704 (6231) 92	959(8488) 91	1217(10771) 90	1466(12975) 89			
	106 (28.0) (rpm)	444 (3929) 107	700 (6195) 107	949 (8399) 106	1197(10594) 105	1446(12798) 103			
	121 (32.0) (rpm)	425 (3762) 123	674 (5965) 122	923 (8169) 121	1156(10231) 120				
	136 (36.0) (rpm)	394 (3487) 138	645 (5708) 138	893 (7903) 137	1120(9912) 135				
	151 (40.0) (rpm)	365 (3230) 153	609 (5390) 152	864 (7647) 151	1080(9559) 150				
	Max Cont.	189 (50.0) (rpm)	325 (2876) 191	585 (5178) 190	829 (7337) 189	1047(9267) 188			
	Max Int.	227 (60.0) (rpm)		525 (4647) 230	809 (7160) 229	1020(9028) 226			

# HIGH TORQUE, LOW SPEED MOTORS

## 10,000-SERIES

The 10,000 series motor adapts the advanced GEROLER™ gear set design with DISC distribution flow and high pressure. These motors can be supplied with various options to meet application requirements. The output shaft tapered roller bearings permit high axial and radial forces offering a smooth operation during low pressure start up and high pressure operation.

These low weight advanced construction design motors are manufactured in accordance with the requirements of the ISO 9001:2000 quality system.

### Technical Specifications

Fluidyne			DISPLACEMENT cm <sup>3</sup> /r (in <sup>3</sup> /r)			
			315 cm <sup>3</sup> 333 (20.3)	500 cm <sup>3</sup> 518 (31.6)	630 cm <sup>3</sup> 666 (40.6)	1000 cm <sup>3</sup> 990 (60.4)
<i>Char Lynn reference</i>			345 cm <sup>3</sup> (21.0)	480 cm <sup>3</sup> (29.3)	665 cm <sup>3</sup> (40.6)	940 cm <sup>3</sup> (57.4)
MOUNTING	SHAFTS	PORTS				
Standard SAE C-Mount	2-1/4 inch Straight Key Shaft	1-5/16 O-ring	WF1191028	WF1191029	WF1191030	WF1191031
		1 1/4 inch Split Flange	WF1191040	WF1191041	WF1191042	WF1191043
	2-1/8 inch 16T Spline	1-5/16 O-ring	WF1191032	WF1191033	WF1191034	WF1191035
		1 1/4 inch Split Flange	WF1191044	WF1191045	WF1191046	WF1191047
	2-1/4 Inch Tapered	1-5/16 O-ring	WF1191036	WF1191037	WF1191038	WF1191039
		1 1/4 inch Split Flange	WF1191048	WF1191049	WF1191050	WF1191051
Wheel Mount	2-1/4 inch Straight Key Shaft	1-5/16 O-ring	WF1201005	WF1201006	WF1201007	WF1201008
		1 1/4 inch Split Flange	WF1201017	WF1201018	WF1201019	WF1201020
	2-1/8 inch 16T Spline	1-5/16 O-ring	WF1201009	WF1201010	WF1201011	WF1201012
		1 1/4 inch Split Flange	WF1201021	WF1201022	WF1201023	WF1201024
	2-1/4 Inch Tapered	1-5/16 O-ring	WF1201013	WF1201014	WF1201015	WF1201016
		1 1/4 inch Split Flange	WF1201025	WF1201026	WF1201027	WF1201028
BEARINGLESS		1-5/16 O-ring	WF1211007	WF1211008	WF1211009	WF1211010
		1 1/4 inch Split Flange	WF1211011	WF1211012	WF1211013	WF121-1014
Max Torque (in-lbs)	Continuous		8,181	12,824	14,504	17,821
	Intermittent		9,728	15,742	17,688	20,164
Max Pressure (PSI)	Continuous		3,045	3,045	3,045	3,045
	Intermittent		3,625	3,625	3,625	3,625
Max Flow (GPM)	Continuous		39.6	39.6	39.6	39.6
	Intermittent		59.4	59.4	59.4	59.4
Max RPM	Continuous		446	386	223	145
	Intermittent		649	425	331	220
Weight kg (lbs)	Standard or Wheel Mount		43.5 (96.0)	45.5 (100.0)	46.3 (100.0)	47.2 (104.0)
	Bearingless		31.3 (69.0)	33.1 (73.0)	33.1 (73.0)	34.9 (77.0)

Continuous = maximum of continuous operation

Intermittent = maximum operating range for 6 seconds per minute

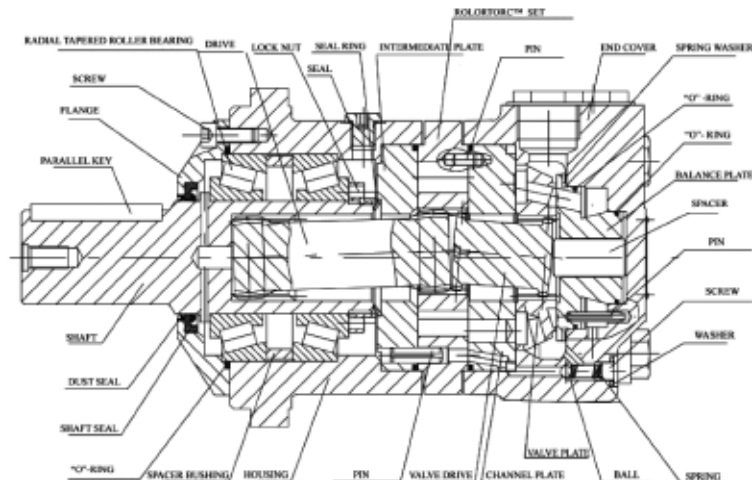

# HIGH TORQUE, LOW SPEED MOTORS

## 10,000-SERIES SHAFT DATA

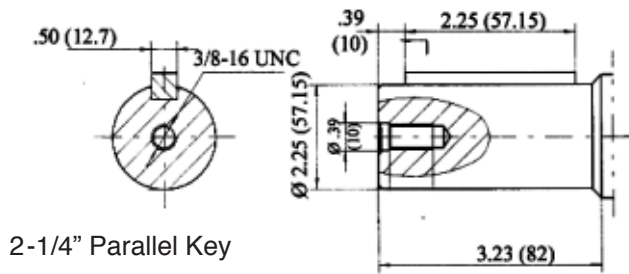
**01**

2-1/4" Parallel Key

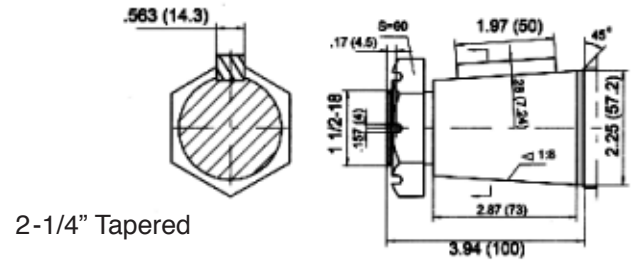
**02**

2-1/4" Tapered

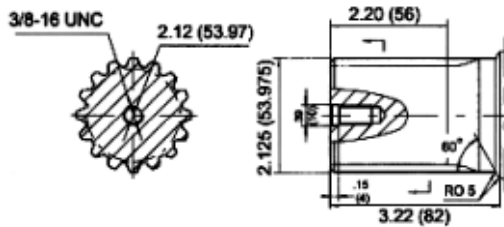
**03**

2-1/8" 16 Tooth Spline 8/16 DP 30° FRSF

## MODEL CODE - 10,000 SERIES

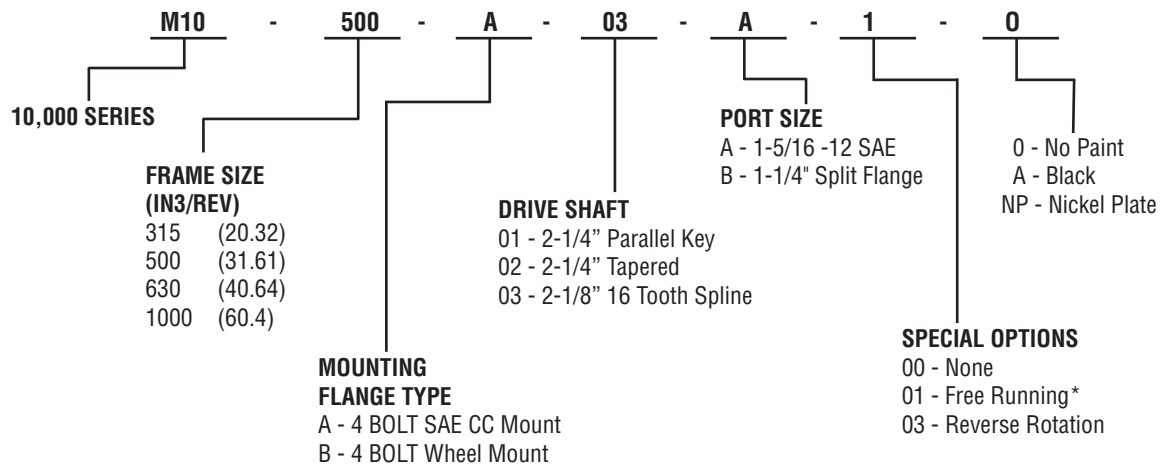

Additional flange and drive shaft options available please consult factory

\*Available on selected models

## 10,000 SERIES INSTALLATION DATA

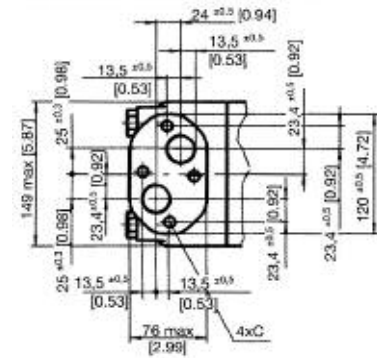
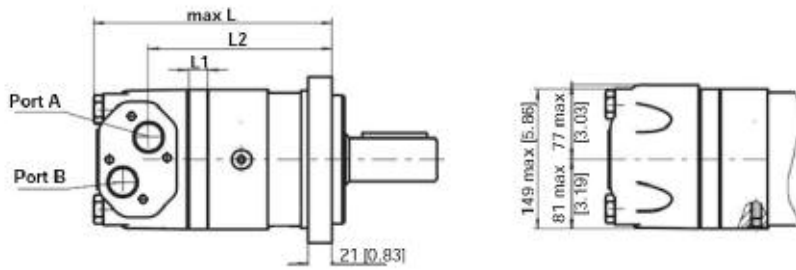

	[INCHES]			MILLIMETERS		
MODEL	L	L1	L2	L	L1	L2
315	[9.69]	[0.79]	[7.44]	246	20	189
500	[10.28]	[1.38]	[8.03]	261	35	204
630	[10.75]	[1.85]	[8.50]	273	47	216
1000	[11.89]	[3.02]	[9.84]	302	74	241

### PORT & DRAIN PORT ORDERING CODES

ORDER CODE	A	DEPTH
PORTS - A and B	1-5/16-12UN	18 mm
TANK PORT - T	9/16-18UNF	12 mm
BOLTS - C	4-M12	10 mm

### A - 4 Bolt SAE CC Mount

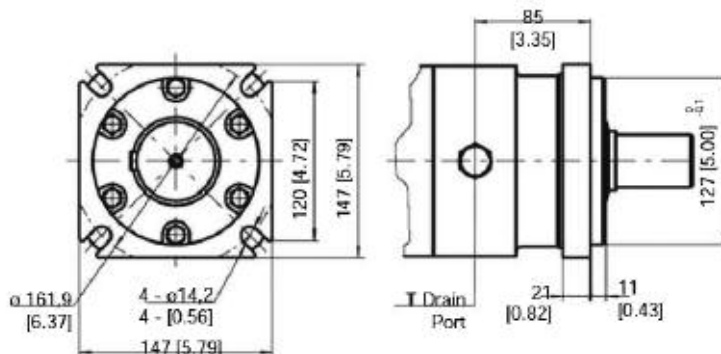

### B - 4 Bolt Wheel Mount

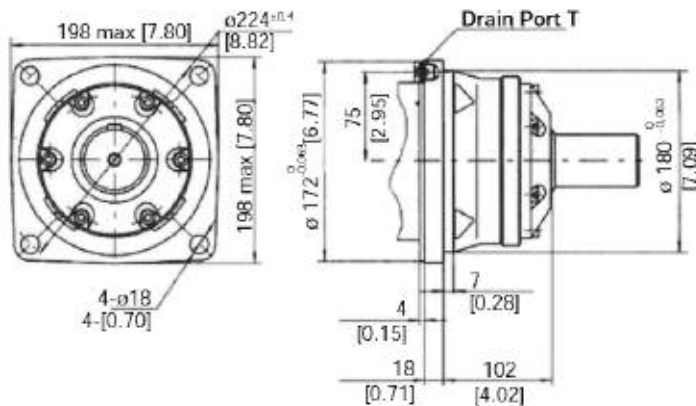



# HIGH TORQUE, LOW SPEED MOTORS

## SHAFT SEAL RATED PRESSURE

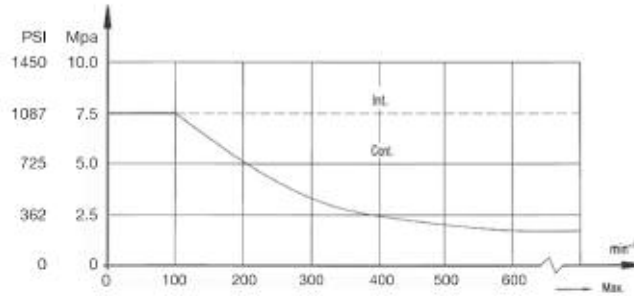
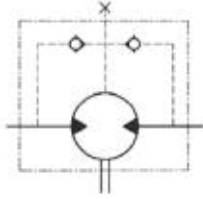

## CASE DRAIN

In applications without a motor drain line, the pressure exerted on the shaft seal is marginally in excess of the return line pressure. When the drain line is used the pressure exerted on the shaft seal is equal to the return line pressure.

## SHAFT ROTATION DIRECTION

STANDARD ROTATION VIEWED FROM SHAFT END

Port A pressurized = CW rotation  
Port B pressurized = CCW rotation

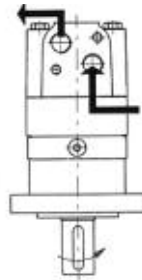

## RADIAL FORCES

Curve "A" shows max radial shaft load. Any shaft loads exceeding these values quoted in the curve will involve risk of breakage. The two other curves apply to a B10 bearing life of 3000 hours at 200 RPM.

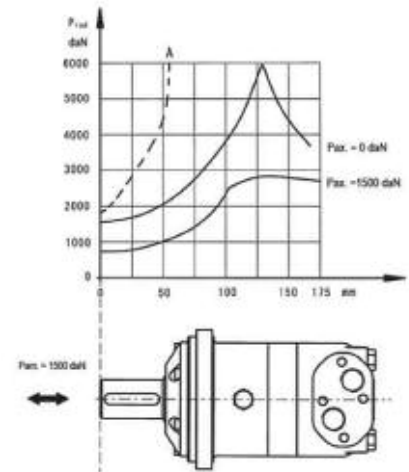

## 10,000 SERIES TECHNICAL DATA

10,000 SERIES 315		333 Cm <sup>3</sup> /Rev 20.32 in <sup>3</sup> /Rev					Max Cont.		Max Int.	
Pressure Bar (psi)		70 (1030)	100 (1470)	140 (2060)	160 (2355)	180 (2652)	200 (2950)	210 (3090)	240 (3535)	
F L O W	LPM (GPM)	Torque Mn (in.Lbs) Speed Specification								
	30 (7.92)	305 (2588) 89 rpm	435 (3850) 85 rpm	605 (5143) 79 rpm	718 (6354) 71 rpm	790 (6992) 70 rpm	892 (7894) 68 rpm	942 (8337) 62 rpm	1060 (9381) 55 rpm	
	60 (15.85)	303 (2672) 183 rpm	445 (3938) 179 rpm	625 (5531) 174 rpm	736 (6514) 168 rpm	828 (7528) 163 rpm	925 (8186) 160 rpm	968 (8567) 154 rpm	1097 (9708) 148 rpm	
	90 (23.77)	300 (2655) 275 rpm	440 (3894) 272 rpm	625 (5531) 266 rpm	730 (6461) 258 rpm	826 (7310) 254 rpm	922 (8160) 248 rpm	962 (8514) 242 rpm	1082 (9576) 235 rpm	
	105 (27.74)	295 (2611) 325 rpm	435 (3850) 320 rpm	620 (5487) 312 rpm	726 (6425) 306 rpm	822 (7275) 300 rpm	917 (8115) 292 rpm	958 (8478) 290 rpm	1078 (9540) 285 rpm	
	120 (31.70)	290 (2566) 371 rpm	431 (3814) 366 rpm	610 (5399) 359 rpm	720 (6372) 350 rpm	820 (7257) 345 rpm	912 (8071) 337 rpm	952 (8425) 332 rpm	1070 (9470) 325 rpm	
	150 (39.50)	278 (2460) 464 rpm	411 (3637) 459 rpm	602 (5328) 454 rpm	716 (6337) 445 rpm	802 (7098) 435 rpm	904 (8000) 428 rpm	942 (8337) 422 rpm	1057 (9354) 412 rpm	
	Max Cont.	190 (50.19)	260 (2301)	392 (3469)	588 (5204)	710 (6284)	795 (7036)	892 (7894)	930 (8231)	
	Max Int.		595 rpm	588 rpm	582 rpm	575 rpm	568 rpm	562 rpm	555 rpm	

10,000 SERIES 500		518 Cm <sup>3</sup> /Rev 31.61 in <sup>3</sup> /Rev					Max Cont.		Max Int.	
Pressure Bar (psi)		70 (1030)	100 (1470)	140 (2060)	160 (2355)	180 (2652)	200 (2950)	210 (3090)	240 (3535)	
F L O W	LPM (GPM)	Torque Mn (in.Lbs) Speed Specification								
	30 (7.92)	442 (3912) 57 rpm	675 (5975) 55 rpm	998 (8832) 53 rpm	1180 (10443) 52 rpm	1280 (11151) 50 rpm	1410 (12478) 48 rpm	1485 (13142) 44 rpm	1759 (15567) 40 rpm	
	60 (15.85)	455 (4026) 117 rpm	685 (6062) 115 rpm	1025 (9071) 111 rpm	1210 (10708) 106 rpm	1265 (11195) 101 rpm	1445 (12788) 97 rpm	1510 (13364) 95 rpm	1780 (10930) 90 rpm	
	90 (23.77)	450 (3982) 186 rpm	678 (6000) 184 rpm	1020 (9023) 183 rpm	1205 (10664) 180 rpm	1260 (11151) 178 rpm	1450 (12832) 173 rpm	1520 (13452) 170 rpm	1786 (15806) 166 rpm	
	105 (27.74)	445 (3938) 205 rpm	672 (5947) 202 rpm	1012 (8956) 198 rpm	1200 (10620) 194 rpm	1255 (11106) 192 rpm	1446 (12797) 187 rpm	1513 (13390) 186 rpm		
	120 (31.70)	440 (3894) 240 rpm	668 (4553) 238 rpm	1005 (8894) 235 rpm	1194 (10567) 232 rpm	1250 (11062) 230 rpm	1399 (12381) 226 rpm	1510 (13363) 225 rpm		
	150 (39.50)	435 (3850) 294 rpm	663 (5867) 290 rpm	1000 (8850) 286 rpm	1186 (10496) 282 rpm	1246 (11027) 278 rpm				
	Max Cont.	190 (50.19)	428 (3788)	658 (5823)	993 (8788)					
	Max Int.		373 rpm	368 rpm	362 rpm					

# HIGH TORQUE, LOW SPEED MOTORS

1-800-842-5377

## 10,000 SERIES TECHNICAL DATA

10,000 SERIES 630		666 Cm <sup>3</sup> /Rev 40.64 in <sup>3</sup> /Rev				Max Cont.	Max Int.	
Pressure Bar (psi)		70 (1030)	100 (1470)	140 (2060)	160 (2355)	180 (2652)	200 (2950)	210 (3090)
F L O W	LPM (GPM)	Torque Mn (in.Lbs) Speed Specification						
	30 (7.92)	610 (5399)	880 (7788)	1280 (11328)	1404 (12425)	1616 (14302)	1780 (15753)	1843 (16311)
		43 rpm	41 rpm	38 rpm	36 rpm	34 rpm	31 rpm	30 rpm
	60 (15.85)	615 (5443)	888 (5443)	1336 (11824)	1412 (12496)	1628 (14408)	1800 (15930)	
		90 rpm	87 rpm	84 rpm	82 rpm	81 rpm	77 rpm	
	90 (23.77)	608 (5381)	878 (7770)	1331 (11779)	1422 (12585)	1640 (14514)	1810 (16019)	
		140 rpm	138 rpm	136 rpm	134 rpm	132 rpm	128 rpm	
	105 (27.74)	600 (5310)	872 (7717)	1326 (11135)	1415 (12523)	1632 (14443)	1790 (15842)	
		164 rpm	162 rpm	158 rpm	155 rpm	153 rpm	149 rpm	
	120 (31.70)	595 (5266)	865 (7655)	1310 (11594)	1405 (12434)	1625 (14381)	1780 (15753)	
	186 rpm	183 rpm	180 rpm	177 rpm	174 rpm	171 rpm		
Max Cont.	150 (39.50)	590 (5222)	855 (7567)	1302 (11533)	1398 (12372)			
		235 rpm	232 rpm	228 rpm	224 rpm			
Max Int.	190 (50.19)	586 (5186)	864 (7487)					
		298 rpm	292 rpm					

10,000 SERIES 1000		990 Cm <sup>3</sup> /Rev 60.4 in <sup>3</sup> /Rev		Max Cont.	Max Int.
Pressure Bar (PSI)		70 (1015)	100 (1450)	140 (2030)	160 (2320)
F L O W	LPM (GPM)	Torque in Nm (in.Lbs) Speed specification			
	30 (7.90)	978 (8649)	1410 (12410)	1980(12511)	20075(2270)
		28	27	26	24
	60 (15.9)	992 (8773)	1422 (12576)	2015(17821)	2280(20129)
		58	56	55	51
	90 (23.8)	987 (8129)	1425 (12603)	2003(17715)	2276(20129)
		87	85	82	76
	105 (27.7)	983 (8694)	1418 (12541)	1994(17635)	2243(19837)
		101	98	94	87
	120 (31.7)	975 (8623)	1409 (12461)	1988(17582)	2224(19669)
	113	109	105	100	
Max Cont.	150 (39.6)	961 (8499)	1368 (12099)	1903(16830)	
		140	136	123	
Max Int.	190 (50.2)	943 (8340)	1338 (11833)		
		170	158		



31915 Groesbeck Highway • Fraser, Michigan 48026  
PH: 1-586-296-7200 • FAX: 1-586-296-7210  
[www.FluiDyneFP.com](http://www.FluiDyneFP.com) • Email: [cs@FluiDyneFP.com](mailto:cs@FluiDyneFP.com)