



life.augmented

# Motor control Reference Guide





# Content

Introduction .....	3
3-phase brushless motors .....	4
Stepper motors .....	12
Brushed DC motors .....	18
Universal motors .....	23
Single-phase AC induction .....	26
Switched reluctance motors.....	31
Power factor correctors .....	34
Microcontrollers .....	38
Gate drivers solution for IGBTs and MOSFETs.....	45
Signal conditioning .....	47

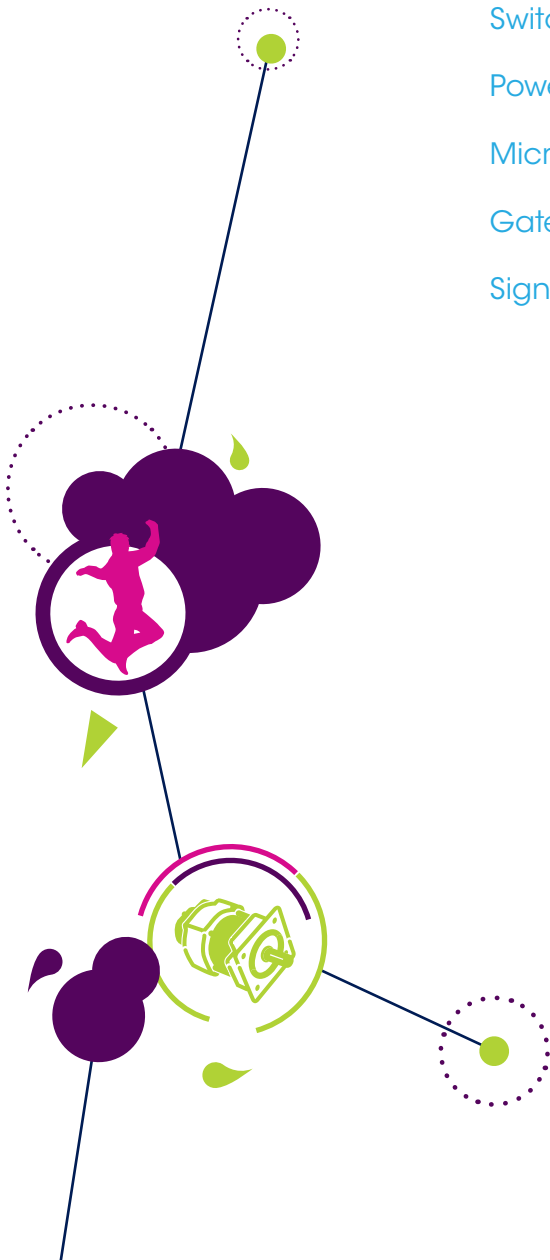



# Introduction



## ST's commitment to motor control reinforces the environmental revolution

In line with the environmental revolution, electric motor control is moving very quickly in the direction of higher efficiency for motors and drives. Moreover, an increased level of integration at optimum cost is required to support market penetration of the new technologies, as well as higher safety and better reliability. Committed to electric motor control for more than 20 years, ST was among the first to recognize today's trends. ST is riding the winds of change with a set of innovations such as integrated intelligent power modules and monolithic motor drivers, fast and efficient power switches, voltage-transient protected Triacs, and powerful and safe microcontrollers.

Whichever motor technology you use, from traditional and rugged ones to the most modern and efficient, ST is able to supply the right electronic devices.

### STAY UP-TO-DATE

For more information and up-to-date material, visit motor control application page on ST's website at <http://www.st.com/motorcontrol>





# 3-phase brushless motors

## Overview

Despite their different structures, all three-phase AC induction motors (AC IM) and three-phase permanent magnet motors (BLDC, PMSM or PMAC) are driven by a PWM-modulated three-phase bridge (three half bridges) so as to supply the motor with variable frequency and amplitude three-phase voltages and currents.

To give the greatest design freedom (for example, the selection of turn-on and turn-off power switch resistors), ST's product portfolio has specific products for both high and low-voltage applications with a wide package choice for discrete MOSFETs or IGBTs and related gate drivers.

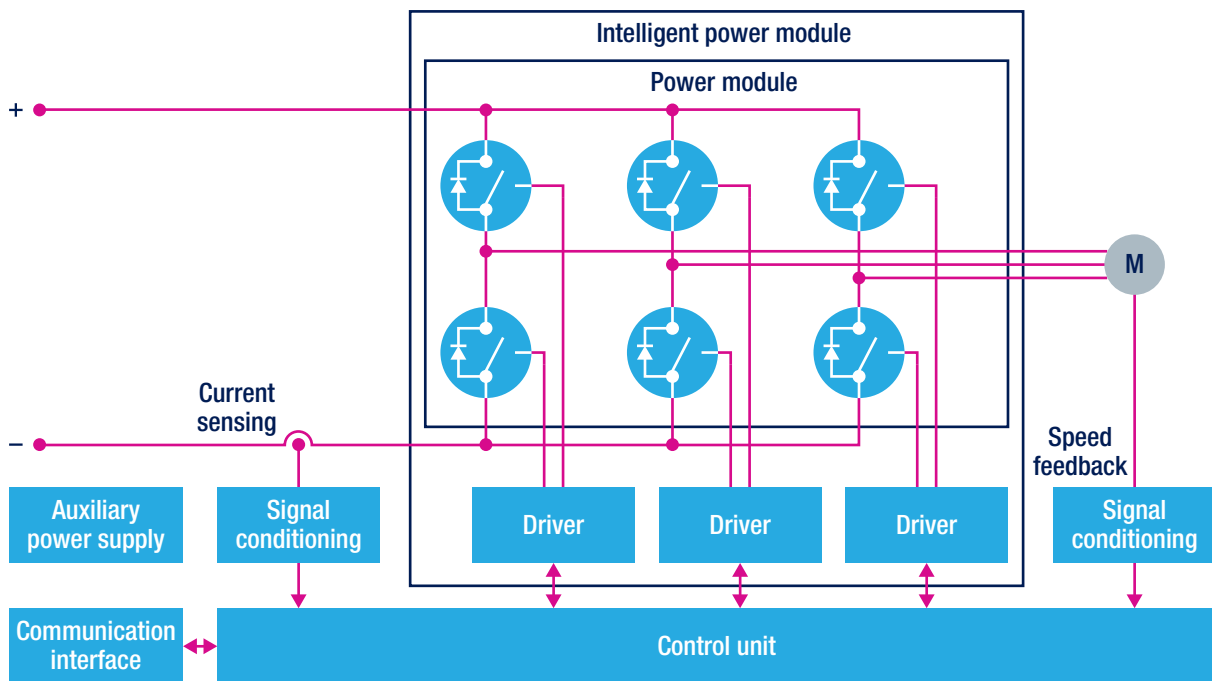

High Voltage three-phase brushless motor drive block diagram

## KEY PRODUCTS

### SLLIMM™ 2<sup>nd</sup> series

The SLLIMM series, small low-loss intelligent molded module family of intelligent power modules combine IGBT power switches in a three-phase IGBT inverter stage configuration with freewheeling diodes, control ICs for gate driving, protections and other optional features in a single package, replacing more than 10 discrete devices.

The **SLLIMM 2<sup>nd</sup> series** has been designed using a new internal configuration with two drivers, one high-side driver and one low-side driver.

This new approach allows a more compact package and new advanced protection functions, thanks to the new features showed by low-side driver.

Two IPM versions are available, the full molded and the DBC (Direct Bonded Copper) both compatible each other.

The products belonging to the new SLLIMM 2<sup>nd</sup> series show the best compromise between conduction and switching energy with an outstanding robustness and EMI behavior, making the new product ideal to enhance the efficiency of compressors, pumps, fans and low power motors working up to 20 kHz in hard-switching circuitries and for an application power range from 300 W to 3K W.

This series will complement and overcome the already available SLLIMM series in term of features, packages' types and flexibility.

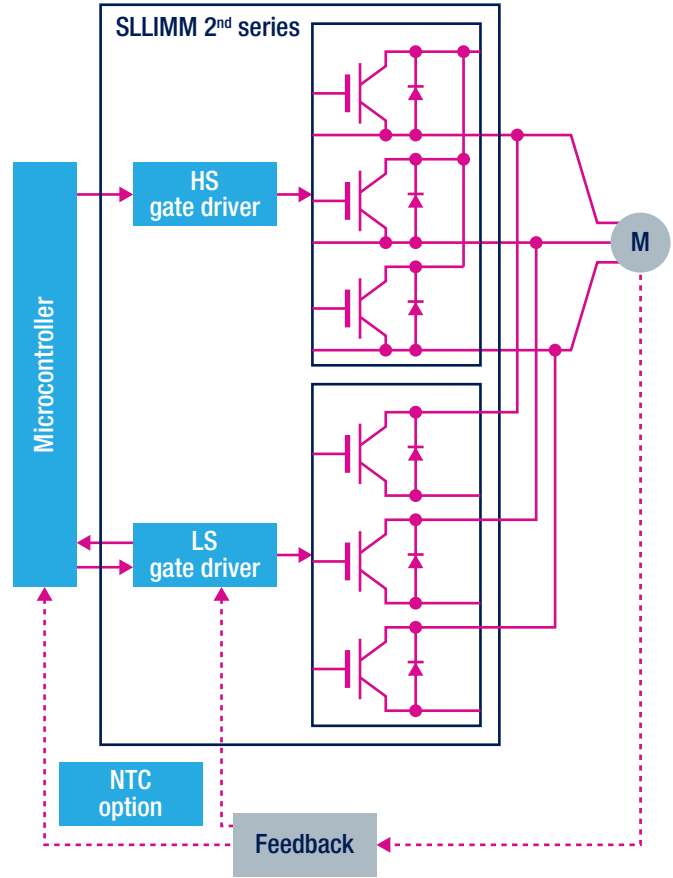

### SLLIMM™-nano

The **SLLIMM™-nano** has been designed using an internal structure of the inverter stage that includes three half-bridge HVICs for gate driving and six IGBTs with freewheeling diodes.

In addition to the first series of this product a new series has been introduced, the new series shows a new package solution with mounted slots to allow a better and easy screw on heatsink.

In add the in line version and the option with and without stand-off leads' packages are available.

The package is optimized for thermal performance and compactness in built-in motor applications, or other low power applications where assembly space is limited.

SLLIMM™-nano products show the best compromise between conduction and switching energy with an outstanding robustness and EMI behavior, making the product ideal to enhance the efficiency of compressor, pumps, fans and low power motors working up to 20 kHz in hard-switching circuitries.

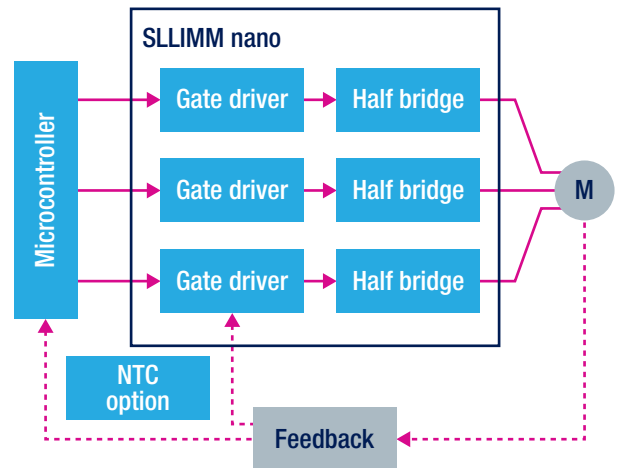

## 3-PHASE BRUSHLESS MOTORS SLLIMM™ 2<sup>ND</sup> SERIES

Package	Part number	Collector current @ 25°C (@ 80°C) (A)	NTC	Voltage (V)	Smart shutdown function	Rthi-c (max) (°C/W)	Isolation voltage (V)	Comparator for fault protection
SDIP2F-26L	STGIF5CH60TS-L(E) <sup>1</sup>	8 (5)	Yes	600	Yes	5	1500	Yes
	STGIF7CH60TS-L(E) <sup>1</sup>	10 (7)	Yes	600	Yes	4.8	1500	Yes
	STGIF10CH60TS-L(E) <sup>1</sup>	15 (10)	Yes	600	Yes	4.6	1500	Yes
SDIP2B-26L	STGIB8CH60TS-L(E) <sup>1,2</sup>	12 (8)	Yes	600	Yes	3	1500	Yes
	STGIB10CH60TS-L(E) <sup>1</sup>	15 (10)	Yes	600	Yes	2.26	1500	Yes
	STGIB15CH60TS-L(E) <sup>1</sup>	20 (15)	Yes	600	Yes	1.85	1500	Yes
	STGIB20M60TS-L(E) <sup>1,2</sup>	25 (20)	Yes	600	Yes	1.4	1500	Yes
	STGIB30M60TS-L(E) <sup>1,2</sup>	35 (30)	Yes	600	Yes	1.2	1500	Yes

Note: 1 (E). option version package with short leads and emitter forward, samples availability to confirm on request  
2. available Q4'15

## THREE-PHASE BRUSHLESS MOTORS SLLIMM-NANO

Package	Part number	Collector current @ 25 °C (A)	NTC	Voltage (V)	Smart shutdown function	Isolation voltage (V)	Comparator for fault protection
NDIP-26L	STGIPN3H60A(T)	3	No (Yes)	600	No	1000	No
	STGIPN3H60 (-H) <sup>1</sup>	3	No	600	Yes	1000	Yes
	STGIPN3H60T-H	3	Yes	600	Yes	1000	Yes
N2DIP-26L	STGIPQ3H60T-HZ(S) <sup>2</sup>	3	Yes	600	Yes	1500	Yes
	STGIPQ3H60T-HL(S) <sup>2</sup>	3	Yes	600	Yes	1500	Yes
	STGIPQ5C60T-HZ(S) <sup>2</sup>	5	Yes	600	Yes	1500	Yes
	STGIPQ5C60T-HZ(S) <sup>2</sup>	5	Yes	600	Yes	1500	Yes

Note: 1 (-H). option version with both inputs active high drive  
2 (S). option version package without stand-off

6

## MOTOR DRIVER ICs

### Monolithic motor driver ICs

ST's BLDC motor drivers combine the control logic and power stage on the same chip, providing reliable and cost-effective solutions to drive brushless DC motors. A full set of embedded hardware protection functions and the extensive diagnostic capability ensure a very robust motor drive, further reducing the number of external components, cost and complexity.

The multiple package options together with the wide operating voltage, current and temperature ranges cover most application requirements, from board space constraints to thermally challenging environments.

Easier development is ensured by reference designs, evaluation boards, and, in some cases, a development environment which includes thermal analysis.

### KEY FEATURES

- Full set of protection functions and extensive diagnostic capability for more robust and compact designs
- Wide operating voltage, current and temperature ranges
- Multiple package options
- Easier development with reference designs, evaluation boards, and, in some cases, thermal analysis

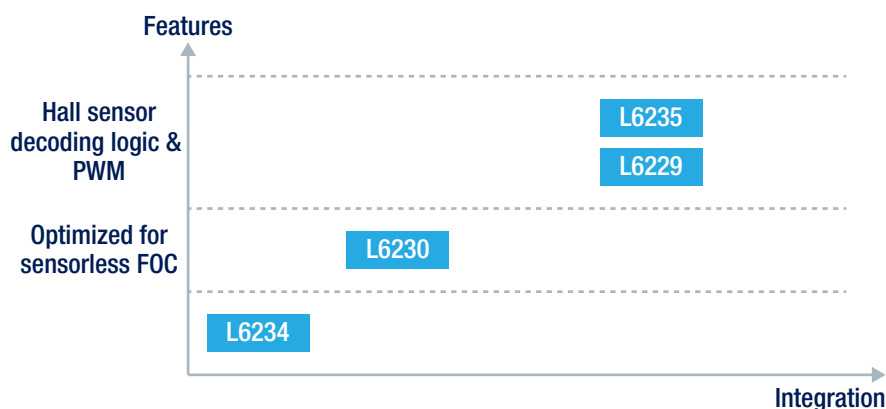

Part number	Description	Package	$R_{DS(on)}$ ( $\Omega$ )	Supply voltage max (V)	Output current RMS max (A)
L6229	DMOS driver for three-phase brushless dc motors	PDIP 24 .3; PowerSO 36; SO-24; VFQFPN 32 5x5x1.0	0.7	52	1.4
L6230	DMOS driver for three-phase brushless DC motors	PowerSO 36; VFQFPN 32 5x5x1.0	0.7	52	1.4
L6234	Three-Phase Motor Driver	PDIP 20; PowerSO-20	0.3	52	2.8
L6235	Three-Phase Brushless DC Motor Driver	PDIP 24 .3; PowerSO 36; SO-24; VFQFPN 48 7x7x1.0	0.3	52	2.8

## DISCRETE POWER SWITCHES

### IGBTs

The ST offers IGBTs with breakdown from 600 V to 1200 V.

These IGBTs have been developed using an advanced proprietary trench gate and field stop structure.

In particular three series of IGBTs are suitable for this type of applications: "H", "M" and "S" series.

These series combine a very low saturation voltage with a minimal collector current turn-off and a maximum junction operating temperature of 175 °C.

The 600 V "H" series, represents an optimum compromise between conduction and switching losses to maximize the efficiency of medium to high switching frequency inverter.

The 650 V and 1200 V "M" series represent an optimum compromise in performance to maximize the efficiency of three phase industrial drive systems where low-loss and short-circuit capability are essential.

The 1200 V "S" series is tailored to get the best trade-off between conduction and switching-off losses to improve significantly the overall performance of three phase industrial drive systems at low switching frequency (<5 kHz).

Collector emitter voltage max (V)	Part number	$I_{CN}$ Collector current max @ 100°C (A)	$V_{CE(SAT)}$ ( $I_{CN}$ @ $T_j = 25$ °C) (V)	Short-circuit rugged	Package
1200	STG*15M120DF3	15	1.85	Yes	T0247, T0-247LL
	STG*25M120DF3	25	1.85	Yes	T0247, T0-247LL
	STG*40M120DF3	40	1.85	Yes	T0247, T0-247LL
	STG*15S120DF3	15	1.55	Yes	T0247, T0-247LL
	STG*25S120DF3	25	1.60	Yes	T0247, T0-247LL
	STG*40S120DF3	40	1.65	Yes	T0247, T0-247LL
600	STG*5H60DF	5	1.45	Yes	D <sup>2</sup> PAK, DPAK, T0220FP, T0220
	STG*7H60DF	7	1.50	Yes	D <sup>2</sup> PAK, T0220FP, T0220
	STG*10H60DF	10	1.50	Yes	D <sup>2</sup> PAK, T0220FP, T0220
	STG*15H60DF	15	1.60	Yes	D <sup>2</sup> PAK, T0220FP, T0220
	STG*20H60DF	20	1.60	Yes	D <sup>2</sup> PAK, T0220FP, T0220, T0247, T03P
650	STG*4M65DF2 <sup>1</sup>	4	1.55	Yes	D <sup>2</sup> PAK, DPAK, T0220FP, T0220
	STG*6M65DF2 <sup>1</sup>	6	1.55	Yes	D <sup>2</sup> PAK, DPAK, T0220FP, T0220
	STG*10M65DF2	10	1.55	Yes	D <sup>2</sup> PAK, T0220FP, T0220
	STG*15M65DF2 <sup>1</sup>	15	1.55	Yes	D <sup>2</sup> PAK, T0220FP, T0220
	STG*20M65DF2 <sup>1</sup>	20	1.60	Yes	D <sup>2</sup> PAK, T0220FP, T0220
	STG*30M65DF2	30	1.55	Yes	D <sup>2</sup> PAK, T0220FP, T0220, T0247 LL

Note: 1. available Q4'15

## Power MOSFETs

ST's MOSFET portfolio offers a broad range of breakdown voltages from 40 V to 550 V, with low gate charge and low on-resistance based on the low-voltage trench process and high-voltage planar process with ultra-fast diodes.



- ### KEY FEATURES
- Up to 550 V breakdown voltage
  - Wide package options
  - Low-voltage state-of-the-art on-resistance
  - Intrinsic fast body diode option
  - Very low on-resistance
  - Dynamic dv/dt ruggedness
  - High current capability
  - Correct Crss/Ciss capacitive ratio and Vth average value
  - Low thermal resistance
  - Thin and powerful package
  - Low Qrr and right softness for bridge configuration

Part number	BV <sub>DSS</sub>	R <sub>DS(on)</sub> max @ 10 V (mΩ)	Drain current (ID) max (A)	Qrr (μC)	Trr (ns)	Package
ST*270N4F3	40	2	160	225	70	DPAK, H²PAK, I²PAK, PowerSO10
ST*160N4LF6	40	<2.2	120	55	57	TO-220, H²PAK
ST*360N4F6	40	<1.8	120	N/A	N/A	TO-220, H²PAK, I²PAK
ST*220N6F7	60	2.4	120	104	69	TO-220, H²PAK
STL220N6F7	60	1.4	260 <sup>1</sup>	70	55	PowerFLAT 5x6
STP80N70F4	68	9.8	85	130	55	TO-220
ST*160N75F3	75	3.7	120	150	70	TO-220, T0247, D²PAK
ST*270N8F7	80	2.2	180	N/A	N/A	TO-220/H²PAK
ST*310N10F7	100	2.7	180	200	85	TO-220/H²PAK
ST*5N52U	525	1500	4.4	95	55	DPAK
STF16N50U	500	470	15	280	85	TO-220FP

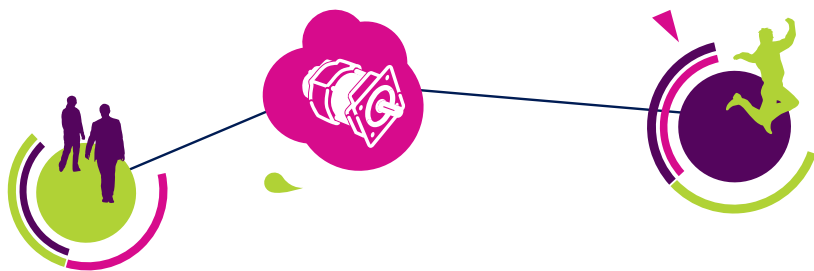



### Gate drivers solution for IGBTs and MOSFETs

ST's power MOSFET and IGBT gate drivers include integrated half-bridge, single and multiple low-side gate drivers and galvanically isolated devices. ST's MOSFET/IGBT drivers provide state-of-the-art integration, reducing BOM cost and final application dimensions, while also increasing robustness and noise immunity.

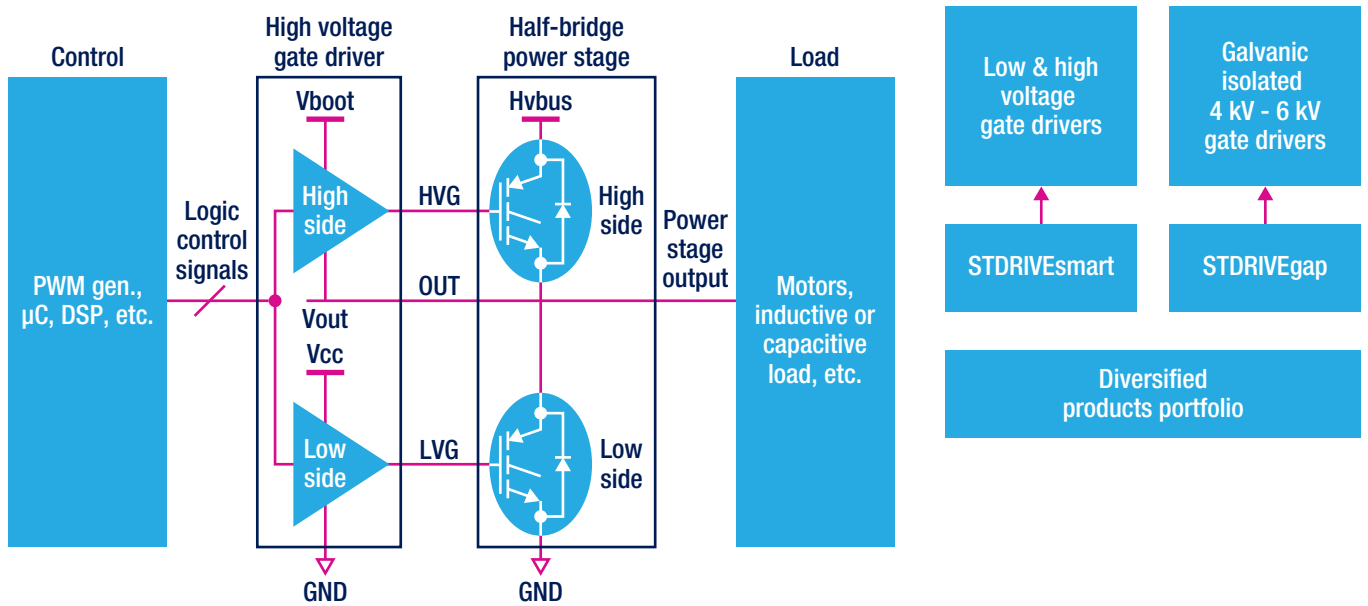

### STDRIVE<sub>SMART</sub> – L639X

- Features
- L6390 + Comparator & Op AMP
  - L6391 + Smart SD integrated + Comparator
  - L6392 + Op Amp integrated
  - L6393 + Shutdown inputs + uncommitted comparator + interlocking & programmable DT
  - L6395 + able to drive asymmetrical loads
  - L6398 High low side inputs, interlocking & DT protections, UVLO Vcc/Vboot

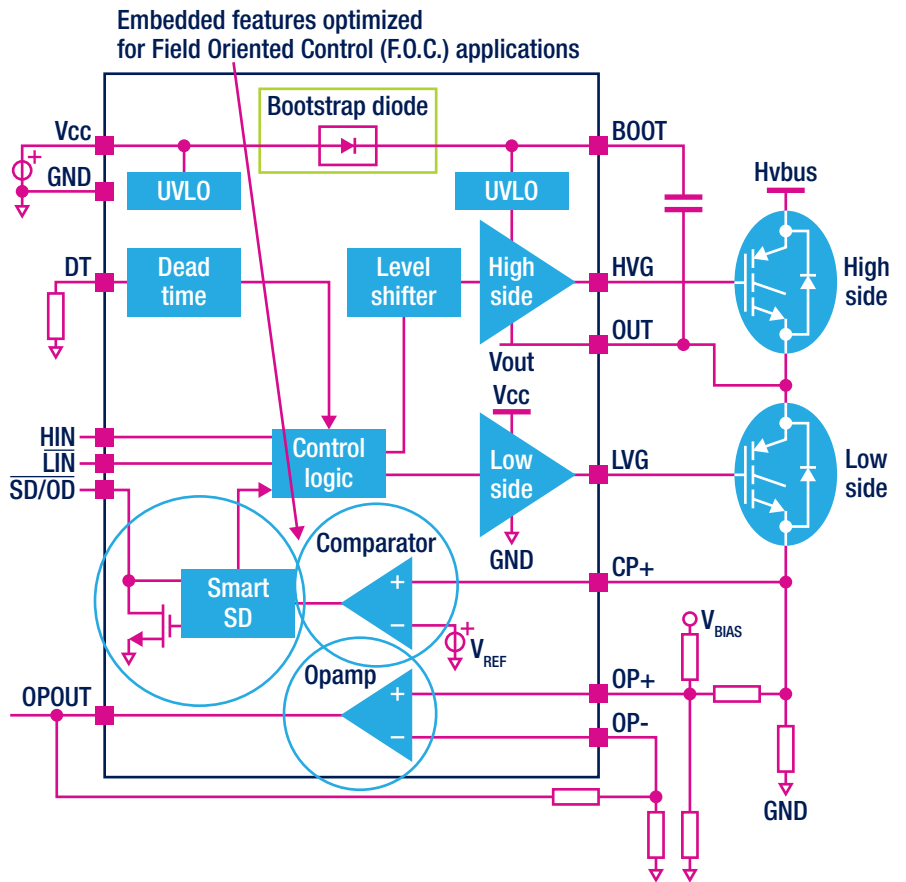

## EVALUATION TOOLS

To ensure the best flexibility and inter-changeability between the power stages and the control stages (which may use different microcontroller part numbers), many of ST's evaluation boards both for microcontrollers and power devices have an MC connector on-board. This connector is ST's standard and is suitable for different control algorithms such as vector control (or field-oriented control) and scalar control (for example, V/f for AC IM).

Any power stages with an MC connector can be used in conjunction with any of the control stages with the same connector. The microcontroller section on page 40 provides more information about ST's offer for microcontrollers and HW and SW tools.

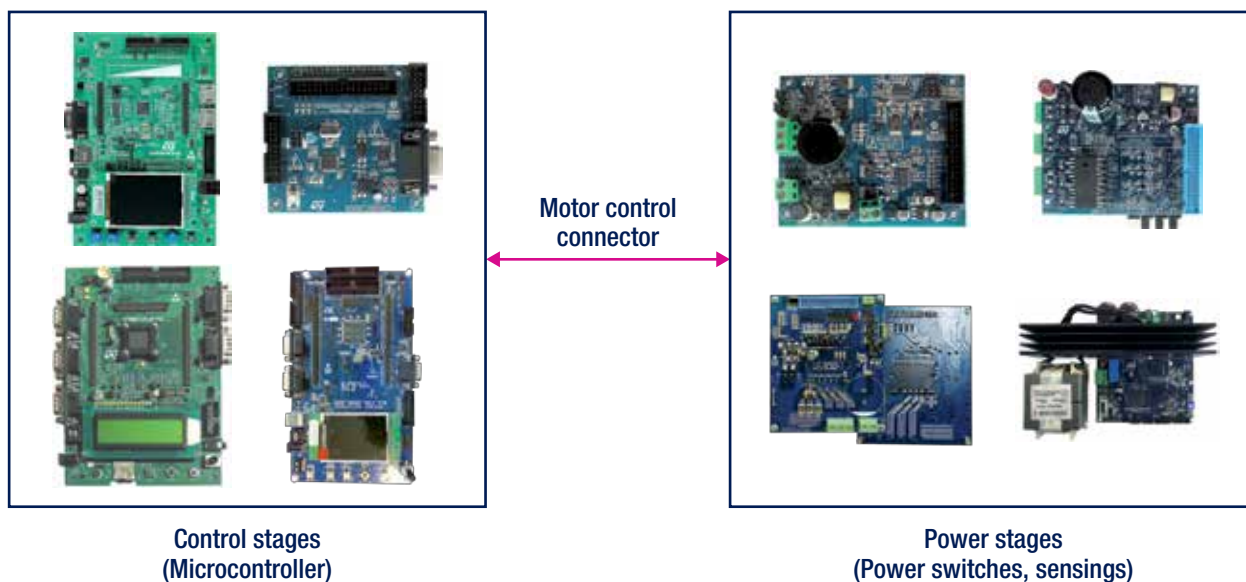

Order code	Description	Eval board	Technical documentation	MC connector availability
STEVAL-IHM021V2	100 W, 3-phase inverter based on L6390 gate driver and UltraFASTmesh™ MOSFET for FOC of 3-phase PMSM	Power stage	UM1491	Yes
STEVAL-IHM023V3	1 kW 3-phase motor control demonstration board featuring L6390 gate drivers and STGP10H60DF IGBT	Power stage	UM1823	Yes
STEVAL-IHM025V1	1 kW 3-phase motor control demonstration board featuring the IGBT SLLIMM™ STGIPL14K60 IPM	Power stage	UM0900	Yes
STEVAL-IHM028V2	2 kW 3-phase motor control evaluation board featuring the STGIPS20C60 IGBT intelligent power module	Power stage	UM1036	Yes
STEVAL-IHM032V1	150 W inverter featuring L639x gate driver and STGD3HF60HD IGBT for 1-shunt based FOC and trapezoidal control	Power stage	UM1078	Yes
STEVAL-IHM034V2	Dual motor control and PFC demonstration board featuring the STM32F103 and STGIPS20C60	Full inverter (MCU on board)	UM1553	No
STEVAL-IHM035V2	3-phase high-voltage inverter power board for FOC and scalar motor control based on the STGIPN3H60 (SLLIMM™-nano) IPM	Power stage	UM1517	Yes
STEVAL-IHM036V1	Low-power motor control board featuring the SLLIMM™ STGIPN3H60 IPM and STM32F100 microcontroller	Full inverter (MCU on board)	UM1483	No
STEVAL-IHM038V1	3-phase BLDC/PMSM motor drive upto 50W, suitable for fan controllers	Full inverter (MCU on board)	UM1697	No
STEVAL-IHM040V1	BLDC/PMSM driver demonstration board based on STM32 and the SLLIMM nano™	Full inverter (MCU on board)	UM1595, UM1594, AN4220	No
STEVAL-IHM042V1	Compact, low-voltage dual motor control evaluation board based on the STM32F303CC and L6230	Full inverter (MCU on board)	UM1605	No
STEVAL-IHM043V1	6-Step BLDC sensorless driver board based on the STM32F051 and L6234	Full inverter (MCU on board)	DB1860, AN4220	No
STEVAL-IHM045V1	3-phase high voltage inverter power board for FOC based on STGIPN3H60A (SLLIMM™-nano)	Power stage	UM1703	No
STEVAL-IFN003V1	PMSM FOC motor driver based on L6230 motor driver and STM32F103 microcontroller	Full inverter (MCU on board)	UM1478	No
STEVAL-IFN004V1	BLDC six-step motor driver based on L6230 motor driver and STM8S105 microcontroller	Full inverter (MCU on board)	UM1477	No

Order code	Description	Eval board	Technical documentation	MC connector availability
STEVAL-SPIMD20V1	Power drive system demonstration kit based on the SPIMD20 integrated motor drive	Full inverter (MCU on board)	DB1505	No
EVAL6229PD	L6229 DMOS Driver for Three-Phase Brushless DC Motor	Full inverter	AN1794; AN1625	No
EVAL6229QR	L6229Q DMOS driver for a three-phase BLDC motor control application	Full inverter	AN3134:	No
EVAL6230QR	L6230Q three-phase brushless DC motor driver demonstration board	Full inverter	AN4243	No
EVAL6235N	L6235 DMOS Driver for Three-Phase Brushless DC Motor	Full inverter	AN1794;	No
EVAL6235PD	L6235 three-phase brushless DC motor driver	Full inverter	DB1409; AN1625	No
EVAL6235Q	Three phase BLDC motor driver mounting the L6235Q	Full inverter	DB1616; AN1625	No
STEVAL-IPM05F <sup>1</sup>	3-phase motor control power board featuring STGIF5CH60TS-L	Power stage	-	Yes
STEVAL-IPM07F <sup>1</sup>	3-phase motor control power board featuring STGIF7CH60TS-L	Power stage	-	Yes
STEVAL-IPM10F <sup>1</sup>	3-phase motor control power board featuring STGIF10CH60TS-L	Power stage	-	Yes
STEVAL-IPM10B <sup>1</sup>	3-phase motor control power board featuring STGIB10CH60TS-L	Power stage	-	Yes
STEVAL-IPM15B <sup>1</sup>	3-phase motor control power board featuring STGIB15M60TS-L	Power stage	-	Yes
STEVAL-IPM20B <sup>1</sup>	3-phase motor control power board featuring STGIB20M60TS-L	Power stage	-	Yes
STEVAL-IPM30B <sup>1</sup>	3-phase motor control power board featuring STGIB30M60TS-L	Power stage	-	Yes
X-NUCLEO-IHM07M1	3-phase motor driver expansion board based on L 6230	Power stage	-	No
X-NUCLEO-IHM09M1 <sup>1</sup>	MC Connector adapter expansion board	Adapter	-	Yes

Note: 1. available Q4'15

## STM32 NUCLEO PACK FOR 3-PHASE, LOW VOLTAGE MOTOR CONTROL

It is designed to allow the evaluation of STM32 and motor driver IC in PMSM/BLDC motor control application (up to 50 V, 1.4 A)

### P-NUCLEO-IHM001

#### NUCLEO-F302R8

Nucleo Board with STM32 for Motor control

#### X-NUCLEO-IHM07M1

Expansion Nucleo Board with STSPIN L6230

#### BLDC Motor

Compact 3 phase Motor

[www.st.com/x-nucleo](http://www.st.com/x-nucleo)



...allow the engineers to easily implement high end motion control algorithms (available with STSW-STM32100 - STM32 PMSM FOC SDK motor control library).



# Stepper motors

## Overview

Stepper motors are widely used in holding and positioning applications in the computer, security, automation and industrial fields. Depending on the number of phases, the winding arrangement and the required level of motion smoothness, ST offers several types of bipolar stepper motor drivers to ensure the best performance for your application.

### UNIPOLAR STEPPER MOTOR DRIVE

In unipolar stepper motors, stator windings share a common terminal; the free terminal of each winding is connected to a separate power switch and the current is allowed to flow in one direction through the motor windings. Diodes are used to clamp the voltage across the switches at turn-off.

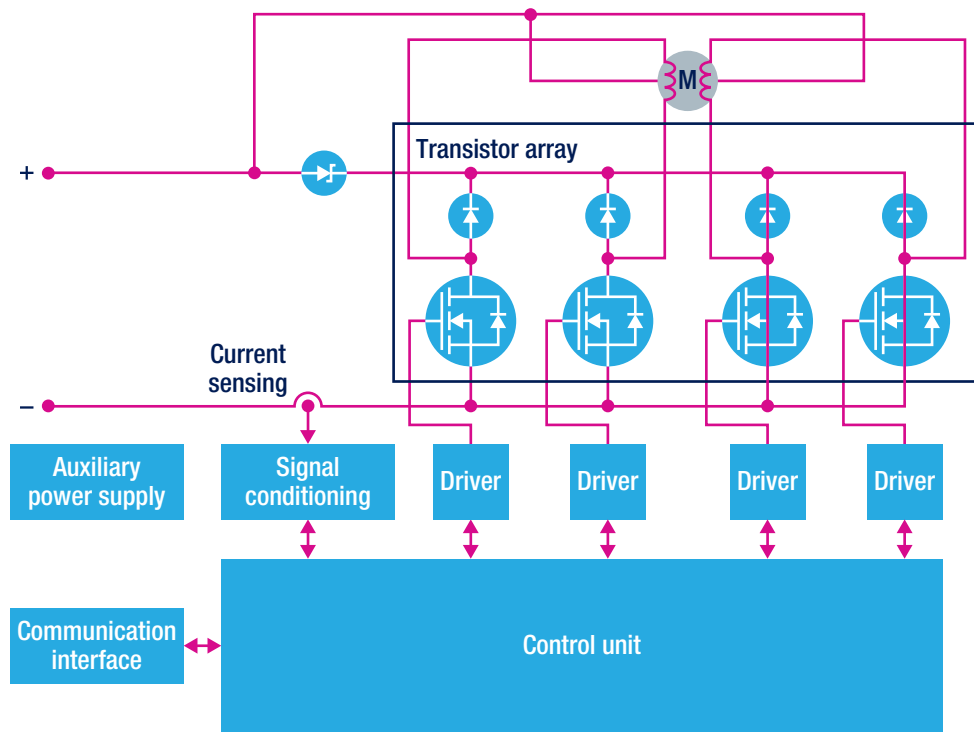

Unipolar stepper motor drive

# BIPOLAR STEPPER MOTOR DRIVE

In bipolar stepper motors, current can flow in both directions; a full-bridge converter is required to drive each of the two windings of a two-phase motor. During motion, the type of electronic control (full step, half step, microstepping) and the resulting phase current waveform impact the vibration level, the acoustic noise, motion smoothness and sensitivity to resonances.

ST fully supports all these configurations with monolithic motor driver ICs (embedding digital controllers, power devices and protection functions) and for higher power, with a controller plus MOSFET combination approach.

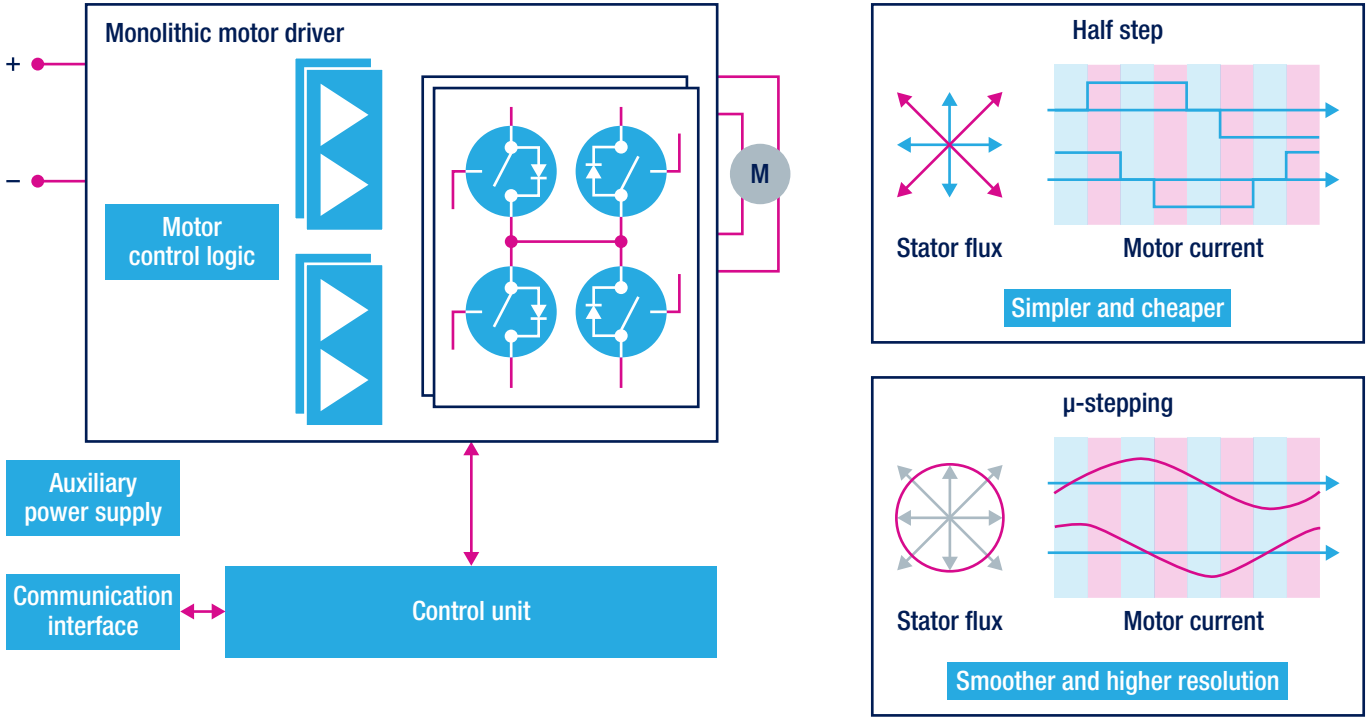

# KEY PRODUCTS

## STSPIN, MOTOR DRIVER ICs

### Motor Driver ICs

A quantum leap in microstepping innovation, L6470/2 and L6480/2 families substitute expensive DSP, analog and power components with a single IC. The digital motion engine integrated in these drivers only requires simple commands through the SPI from the system microcontroller to set acceleration, deceleration, speed and target position and to command the movements. The innovative voltage-mode microstepping technique on the L6470 achieves up to 128 microsteps with extreme smoothness, reducing noise and vibration, while the predictive algorithm and the adaptive decay technique available on the L6472 achieve high accuracy and smoothness with the traditional current-control technique.

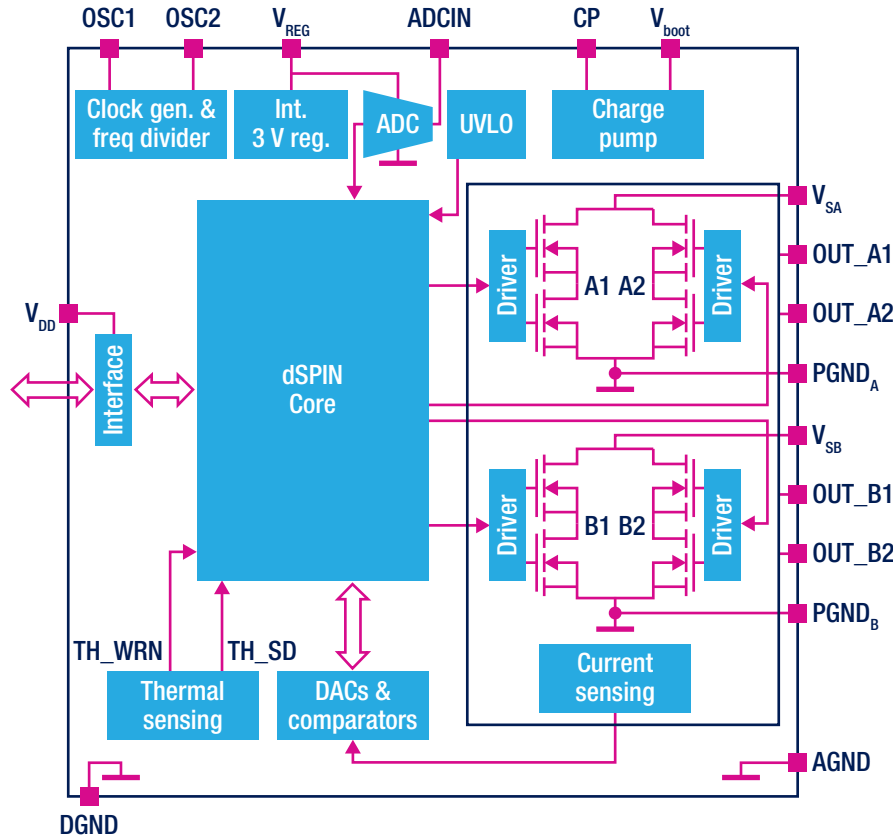

### KEY FEATURES

- Digital motion engine to eliminate expensive DSP
- Voltage mode for impressive smoothness
- Adaptive decay and predictive current control for extreme accuracy
- Great evaluation tools for ease-of-design like never before in microstepping

14

L6474 is a motor driver featuring up to 16 microstep resolution. It uses an adaptive decay control that outperforms traditional implementations, reducing the current ripple and increasing the resolution. The easy step-clock and direction control through direct pins and the configurability through SPI with no need for external components simplify the BOM for cost effectiveness.

The L62x8 is the simplest solution with the decoding logic for the stepper, the power stage array and gate driver in a single chip with a full set of non-dissipative protection features, making the BOM highly competitive.

The new powerSTEP01 is a System-in-package device in a compact 11x4 mm QFN package integrating 8 N-channel 16 mΩ MOSFETs for stepper applications up to 85 V with a SPI programmable controller, providing fully digital control of the motion through a speed profile generation and positioning calculations.

It integrates a dual low RDS(on) full bridge with embedded non-dissipative overcurrent protection.

The device can operate with both voltage mode driving and advanced current control fitting different application needs.

### KEY FEATURES

- Adaptive decay control for higher resolution and lower current ripple
- SPI configurability
- Non-dissipative current sensing



## Controllers

A quantum leap in microstepping innovation, L6480/2 substitute expensive DSP and analog with a single IC controller. The digital motion engine integrated in these drivers only requires simple commands through the SPI from the system microcontroller to set acceleration, deceleration, speed and target position and to command the movements.

The innovative voltage-mode microstepping technique on L6480 achieves up to 128 microsteps with extreme smoothness, reducing noise and vibration, while the predictive algorithm and the adaptive decay technique available on the L6482 achieve high accuracy and smoothness with the traditional current-control technique.

The part number integrates a dual full-bridge gate driver for up to 8 external MOSFETs, thus featuring a scalable solution for different application ratings up to 85 V buses.

## Power Drivers

ST has over 30 different parts for stepper, DC and BLDC motors covering all design needs. The simplest solutions (L62x5 and L62x6) integrates the power stage array and gate driver in a single chip with a full set of non-dissipative protection features, making the BOM highly competitive.

The advanced L62x7 adds PWM current control and the L62x8 adds the decoding logic for the stepper.

The MCU implements motion profiles, generates the precise timing required and drives the motor. This solution is ideal where compactness and configurability are needed at the same time; STSPIN reduces the number of external components needed, while the STM32's computational power and flexible firmware approach make the solution scalable.

### KEY FEATURES

- Scalable products
- Suitable for budgetary  $\mu$ -stepping



Part number	Description	Package	$R_{DS(on)}$ ( $\Omega$ )	Supply voltage max (V)	Output Current RMS max (A)	
powerSTEP01	System-in-package integrating microstepping controller and 10 A power MOSFETs	QFN 11X14	0.016	85	10	Stepper motor
L6470, L6472	Microstepping motor driver with motion engine and SPI	HTSSOP28; PowerSO 36	0.3	45	3	Stepper motor
L6480, L6482	Microstepping motor controller with motion engine and SPI	HTSSOP38	-	85	-	Stepper motor
L6474	Fully integrated microstepping motor driver	HTSSOP28; PowerSO 36	0.3	45	3	Stepper motor
L6460	SPI configurable stepper and DC multi motor driver	TQFP 64 10x10x1.0	0.3	38	2.5	Stepper motor
L6208	Fully Integrated Stepper Motor Driver	PDIP 24 .3; PowerSO 36; SO-24; VFQFPN 48 7x7x1.0	0.3	52	2.8	Stepper motor
L6228	DMOS Dual Full Bridge Driver With PWM current controller and decay selection	PDIP 24 .3; PowerSO 36; SO-24; VFQFPN 32 5x5x1.0	0.7	52	1.4	Stepper motor
L6506	Current controller for stepper motors	PDIP 18; SO-20	62	7	-	Stepper motor
L297	Stepper Motor Controller	PDIP 20; SO-20	-	7	-	Stepper motor
L6205	Dual DMOS Full Bridge Driver	PDIP 20; PowerSO-20; SO-20	0.3	52	2.8	DC/Stepper motor
L6206	Dual DMOS Full Bridge Driver with Diagnostic	PDIP 24 .3; PowerSO 36; SO-24; VFQFPN 48 7x7x1.0	0.3	52	2.8	DC/Stepper motor
L6207	Dual DMOS Full Bridge Driver with PWM Current Controller	PDIP 24 .3; PowerSO 36; SO-24; VFQFPN 48 7x7x1.0	0.3	52	2.8	DC/Stepper motor
L6225	DMOS Dual Full Bridge Driver	PDIP 20; PowerSO-20; SO-20	0.7	52	1.4	DC/Stepper motor
L6226	DMOS Dual Full Bridge Driver with Diagnostic	PDIP 24 .3; PowerSO 36; SO-24; VFQFPN 32 5x5x1.0	0.7	52	1.4	DC/Stepper motor
L6227	DMOS Dual Full Bridge Driver With PWM Current Controller	PDIP 24 .3; PowerSO 36; SO-24; VFQFPN 32 5x5x1.0	0.7	52	1.4	DC/Stepper motor



EVAL6208



EVAL6470



EVAL6480H

## POWER SWITCHES

### Low-voltage power MOSFETs

ST's MOSFET portfolio provides a broad range of breakdown voltages up to 100 V, with low gate charge and low on-resistance, combined with state-of-the-art packaging technology in chip scale form factor with a resulting higher power density, without compromising power dissipation.

**PowerFLAT 5x6 D.I.**



**6.5 mΩ 30 V**

**STL65DN3LLH5**

**PowerFLAT 3.3x3.3**



**3.7 mΩ 30 V**

**STL23NS3LLH7**

**KEY FEATURES**

- Very low on-resistance
- High avalanche ruggedness
- High current capability
- Low thermal resistance
- Thin and powerful package
- Low Qrr and right softness for bridge configuration
- Simplifies driving stage for p-channel FETs (no bootstrap circuitry)

Part number	Polarity	$V_{DSS}$ (V)	$R_{DS(on)max}$ @ 10 V (mΩ)	Drain current ( $I_p$ ) max (A)	Package
STL23NS3LLH7	N-channel	30	3.7	23	PowerFLAT 3.3X3.3
STL65DN3LLH5	Dual N-channel	30	6.5	19	PowerFLAT 5X6 D.I.
STL40DN3LLH5	Dual N-channel	30	18	11	PowerFLAT 5X6 D.I.
STL8DN10LF3	Dual N-channel	100	35	7.8	PowerFLAT 5X6 D.I.

### Gate drivers solution for IGBTs and MOSFETs

ST's power MOSFET and IGBT gate drivers include integrated half-bridge, single and multiple low-side gate drivers and galvanically isolated device. ST's MOSFET/IGBT drivers provide state-of-the-art integration, reducing BOM cost and final application dimensions, while also increasing robustness and noise immunity.

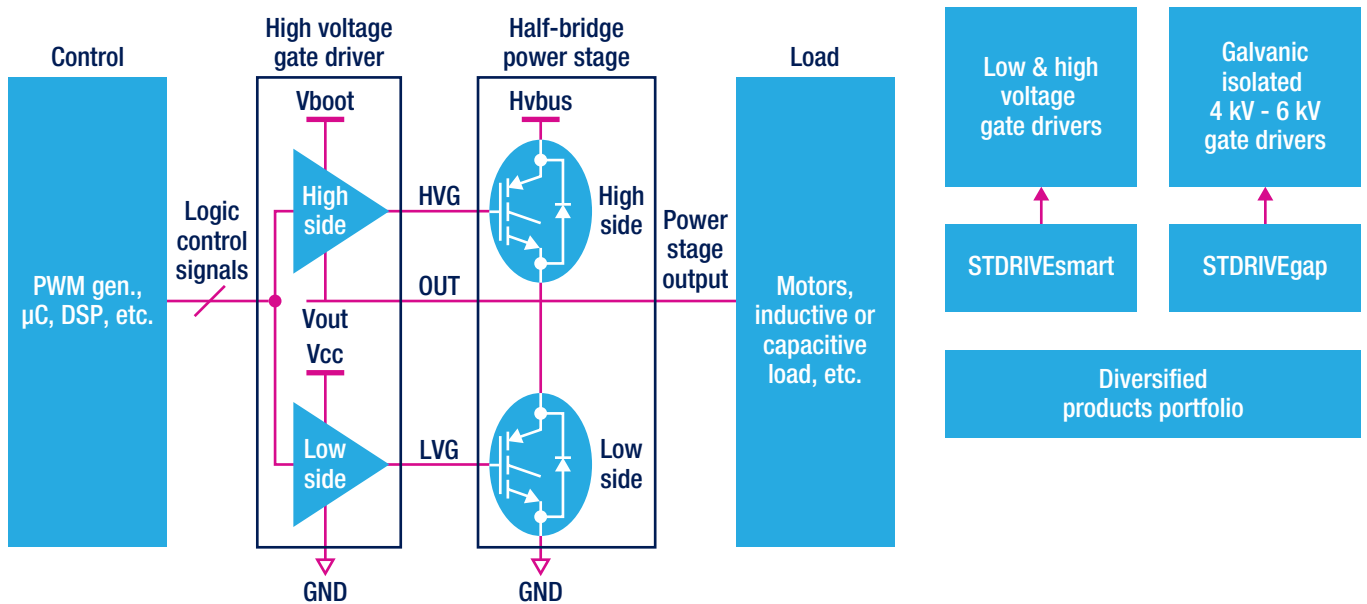



## EVALUATION TOOLS

ST proposes a wide range of evaluation boards for comprehensive evaluation of ST's products and solutions while reducing your development time.

Part number	Description	Core product
X-NUCLEO-IHM01A1	Stepper motor driver expansion board based on L6474 for STM32 Nucleo	L6474PD
X-NUCLEO-IHM02A1 <sup>1</sup>	Motor Driver Expansion Board for STM32 based on L6470	L6470
EVLPOWERSTEP01	System-in-package integrating microstepping controller and 10 A power MOSFETs	POWERSTEP01
EVAL6470H	Fully integrated stepper motor driver	L6470
EVAL6470H-DISC	Discovery kit: development tool to explore L6470 motor driver	L6470
STEVAL-IKM001V1	Evaluation kit based on the L6470H	L6470H
EVAL6470PD	Fully integrated stepper motor driver mounting the L6470 in a high power PowerSO package	L6470
EVAL6472H	Fully integrated stepper motor driver based on the L6472	L6472
EVAL6472H-DISC	Discovery kit: development tool to explore L6472 motor driver	L6472
EVAL6472PD	Fully integrated stepper motor driver mounting the L6472 in a high power PowerSO package	L6472
EVAL6474H	Stepper motor driver mounting the L6474	L6474
EVAL6474PD	Stepper motor driver mounting the L6474 in high power PowerSO package	L6474
EVAL6480H	Fully integrated microstepping motor controller with motion engine and SPI	L6480H
EVAL6482H	Fully integrated microstepping motor controller with motion engine and SPI	L6482H
EVAL6206PD	L6206 DMOS Dual Full Bridge Driver in PowerSO Package Evaluation Board	L6206
EVAL6206Q	Dual full bridge with programmable overcurrent	L6206Q
EVAL6207N	L6207N DMOS Dual Full Bridge Driver with PWM Current Controller	L6207
EVAL6207Q	Dual full bridge with integrated PWM current controllers	L6207Q
EVAL6208N	L6208 DMOS Driver for Bipolar Stepper Motor in PowerDip Package Evaluation board	L6208
EVAL6208PD	L6208 DMOS Driver for Bipolar Stepper Motor in PowerSO Package Evaluation board	L6208
EVAL6208Q	Stepper motor driver mounting the L6208Q	L6208Q
EVAL6225PD	L6225 DMOS Dual full bridge driver	L6225
EVAL6226QR	L6226Q Dual full-bridge driver	L6226Q
EVAL6227PD	L6227 DMOS Dual Full Bridge Driver with PWM Current Controller	L6227
EVAL6227QR	Demonstration board using a dual full-bridge L6227Q for motor control applications	L6227Q
EVAL6228QR	L6228Q: Dual full bridge with PWM current control and translator for stepper reference design board	L6228Q

Note: 1. available Q4'15





# Brushed DC motors

## Overview

A brushed DC motor is an internally-commutated electric motor designed to be run from a direct current power source. Traditionally used in many low-voltage applications, especially those powered by batteries, their power can range from a few watts to several horsepower.

When only one direction of rotation is needed, a single-switch topology with PWM modulation can be used to vary the voltage applied to the motor and thus to control its speed. When positioning is required or when both directions of rotation are needed (car windows, for instance) a full H-bridge with PWM control is used.

At lower power levels, ST offers a wide set of monolithic motor drivers which, with a progressive choice of integrated features,

embedded gate drivers, power transistors, protection functions and even DC-DC converters. For higher powers, ST's portfolio includes discrete MOSFETs and IGBTs and high-voltage gate drivers to implement the required H bridge.

A general-purpose 8-bit microcontroller such as the STM8S can be used to implement these drives<sup>1</sup>.

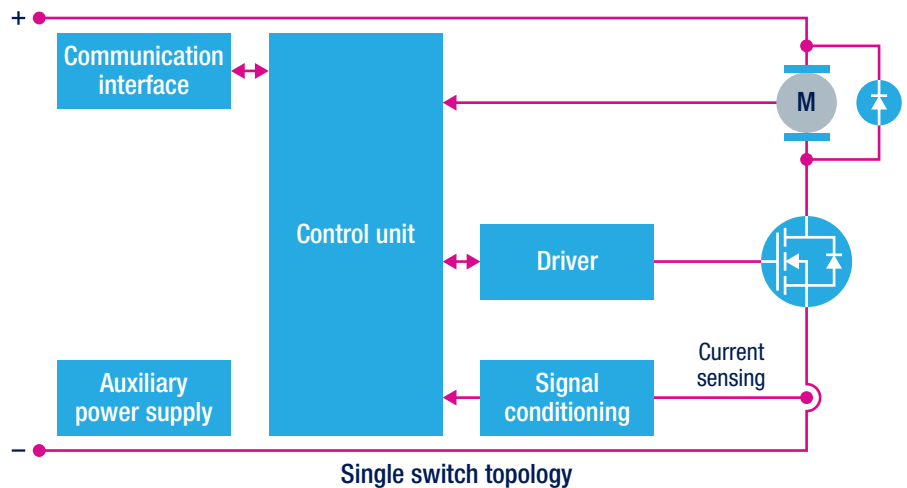

Single switch topology

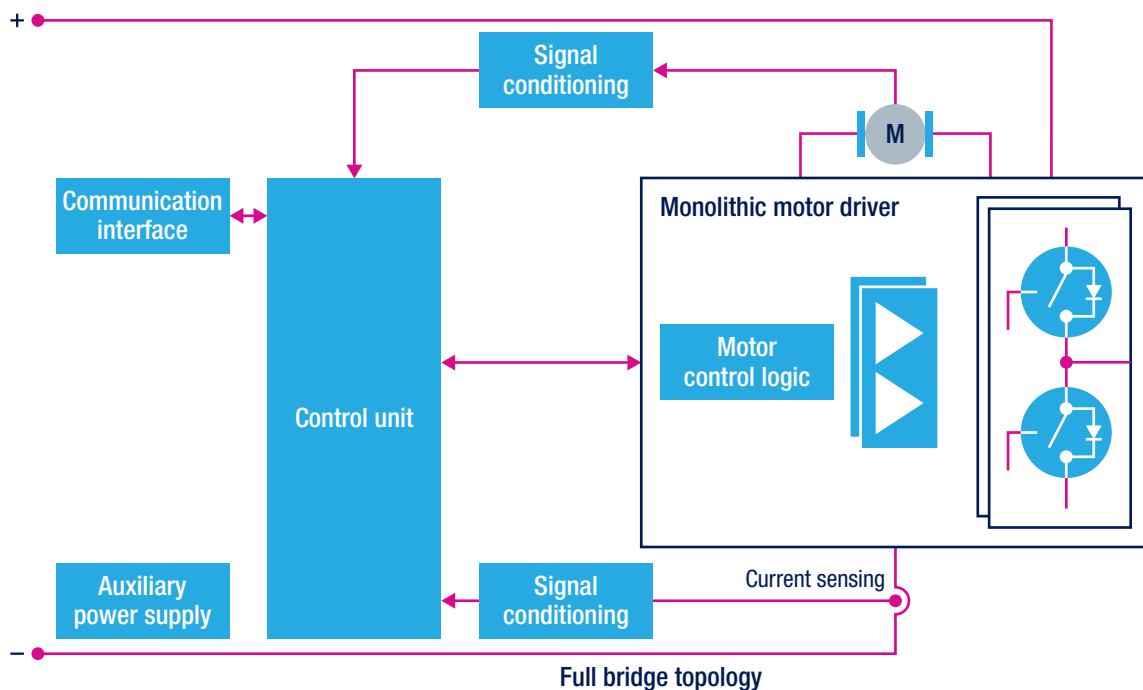

Full bridge topology

Note: 1. Refer to microcontroller chapter on page 40 for more information about suitable part numbers.

## STSPIN, MOTOR DRIVER ICs

ST's set of DC motor drivers combine the control logic and power stage in one chip, featuring reliable and cost-effective solutions.

The STSPIN family addresses stepper, DC and BLDC motors. The family includes the L62x5 and L62x6 that integrate power MOSFETs and gate drivers in one chip, together with a full set of protection functions to reduce the BOM, up to L62x7 that includes PWM current control. There are two options for the power stage, one with a current capability of 2.8 A (L620x family) and the other 1.4 A (L622x family). Both are available in four packages (SO, PowerSO, DIP and the more compact QFN) to meet all assembly and power handling requirements.

The robustness of motor control architectures based on STSPIN devices is ensured by a complete set of protection features embedded in each driver. These include cross conduction protection, thermal shutdown, undervoltage lock out and non-dissipative overcurrent protection (which eliminates the need for an external shunt resistor).

### KEY FEATURES

- Multi-package options to deal with both space constraints and thermal requirements, including small QFN and the powerSO featuring 1C/W Rthj-c
- Extensive set of tools to simplify development
- Extensive diagnostic capability
- Robust and fully embedded protection functions to reduce the number of external components, the cost and the complexity
- Wide operating voltage, current and temperature ranges

Part number	Description	Package	$R_{DS(on)}$ ( $\Omega$ )	Supply voltage max (V)	Output current RMS max (A)
L6201	DMOS Full Bridge Driver	PowerSO-20; SO-20	0.3	48	1
L6202	DMOS Full Bridge Driver	PDIP 18	0.3	48	1
L6203	DMOS Full Bridge Driver	MW 11L	0.3	48	1
L6205	Dual DMOS Full Bridge Driver	PDIP 20; PowerSO-20; SO-20	0.3	52	2.8
L6206	Dual DMOS Full Bridge Driver with Diagnostic	PDIP 24 .3; PowerSO 36; SO-24; VFQFPN 48 7x7x1.0	0.3	52	2.8
L6207	Dual DMOS Full Bridge Driver with PWM Current Controller	PDIP 24 .3; PowerSO 36; SO-24; VFQFPN 48 7x7x1.0	0.3	52	2.8
L6225	DMOS Dual Full Bridge Driver	PDIP 20; PowerSO-20; SO-20	0.7	52	1.4
L6226	DMOS Dual Full Bridge Driver with Diagnostic	PDIP 24 .3; PowerSO 36; SO-24; VFQFPN 32 5x5x1.0	0.7	52	1.4
L6227	DMOS Dual Full Bridge Driver With PWM Current Controller	PDIP 24 .3; PowerSO 36; SO-24; VFQFPN 32 5x5x1.0	0.7	52	1.4
L298	Dual Full Bridge Driver	MW 15L; PowerSO-20	-	36	2
L293D	Dual Full Bridges with Diodes and Thermal Protection; Push-Pull Four Channel Drivers with Diodes	PDIP 16; SO-20	-	36	0.6
L293E	Push-Pull Four Channel Drivers	PDIP 20	-	36	1
L293B	Push-Pull Four Channel Drivers	PDIP 16	-	36	1
L2293Q	Dual Bridge Driver with Thermal protection	VFQFPN 32 5x5x1.0	-	36	0.6

# POWER SWITCHES

## Power MOSFETs

Specifically for DC brushed motors, ST's MOSFET portfolio offers a broad range of breakdown voltages up to 250 V, with low gate charge and low on-resistance combined with excellent source-drain diode performance for reduced power losses. Additionally, the high avalanche ruggedness and the embedded zener diodes for gate-source and gate-drain clamping make the device rugged and reliable.

<b>T0-220</b>  <b>2.7 mΩ 100 V</b> <b>STP310N10F7</b>	<b>H<sup>2</sup>PAK</b>  <b>2.2 mΩ 80 V</b> <b>STH270N8F7-2</b>	<b>DPAK</b>  <b>3.3 mΩ 30 V</b> <b>STD150NS3LLH7</b>	<b>PowerFLAT 5x6</b>  <b>21/30 mΩ 30 V</b> <b>STL40C30H3LL</b>
---	---	--	--

### KEY FEATURES

- Very low on-resistance
- High avalanche ruggedness
- High current capability
- Low thermal resistance
- Low Qrr and right softness for bridge configuration
- Simplifies driving stage for P-channel FETs (no bootstrap circuitry)

20

Part number	Polarity	BV <sub>DSS</sub>	R <sub>DS(on)</sub> max @ 10 V (mΩ)	Drain current (I <sub>D</sub> ) max (A)	Package	Note
STD150NS3LLH7 <sup>1</sup>	N-channel	30	3.3	80	DPA	
STD90NS3LLH7 <sup>1</sup>	N-channel	30	4.2	60	DPAK/T0-220	
STP180NS04ZC	N-channel	33	4.2	120	T0-220	Fully clamped
STP90NS04ZC	N-channel	33	6	80	T0-220	Fully clamped
STP70NS04ZC	N-channel	33	10	80	T0-220	Fully clamped
ST*160N4LF6	N-channel	40	3.2	120	T0-220/H <sup>2</sup> PAK	
ST*360N4F6	N-channel	40	1.8	120	T0-220/H <sup>2</sup> PAK/I <sup>2</sup> PAK	
STP110N55F6	N-channel	55	5.2	110	T0-220	
ST*220N6F7	N-channel	60	2.4	180	T0-220/H <sup>2</sup> PAK	
ST*310N10F7	N-channel	100	2.7	120	T0-220/H <sup>2</sup> PAK	
STP10P6F6	P-channel	60	180	10	DPAK/T0-220	
STL40C30H3LL	N-channel and P-channel	30	21/30	40/30	PowerFLAT 5X6 D.I.	Complementary pair

Note: 1. available Q4'15



## GATE DRIVER ICs

### Gate drivers solution for IGBTs and MOSFETs

ST's power MOSFET and IGBT gate drivers include integrated half-bridge, single and multiple low-side gate drivers and galvanically isolated device. ST's MOSFET/IGBT drivers provide state-of-the-art integration, reducing BOM cost and final application dimensions, while also increasing robustness and noise immunity.

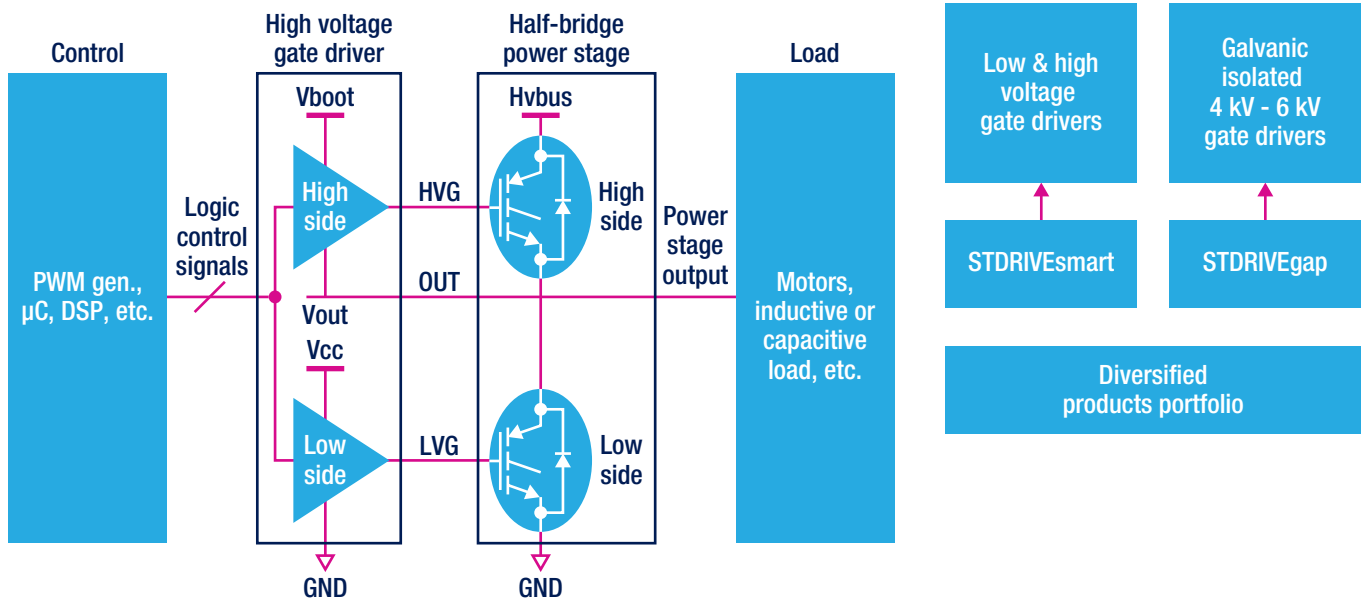

## EVALUATION TOOLS

ST proposes a wide range of evaluation boards that may be used to perform a comprehensive evaluation of ST's products and solutions while reducing your development time.

Part number	Description	Core product
EVAL6205N	L6205 DMOS Dual Full Bridge Driver	L6205
EVAL6206N	L6206 DMOS Dual Full Bridge Driver in PowerDIP Package	L6206
EVAL6206PD	L6206 DMOS Dual Full Bridge Driver in PowerSO Package Evaluation Board	L6206
EVAL6206Q	Dual full bridge with programmable overcurrent	L6206Q
EVAL6207N	L6207N DMOS Dual Full Bridge Driver with PWM Current Controller	L6207
EVAL6207Q	Dual full bridge with integrated PWM current controllers	L6207Q
EVAL6208N	L6208 DMOS Driver for Bipolar Stepper Motor in PowerDip Package Evaluation board	L6208
EVAL6208PD	L6208 DMOS Driver for Bipolar Stepper Motor in PowerSO Package Evaluation board	L6208
EVAL6208Q	Stepper motor driver mounting the L6208Q	L6208Q
EVAL6225PD	L6225 DMOS Dual full bridge driver	L6225
EVAL6226QR	L6226Q Dual full-bridge driver	L6226Q
EVAL6227PD	L6227 DMOS Dual Full Bridge Driver with PWM Current Controller	L6227
EVAL6227QR	Demonstration board using a dual full-bridge L6227Q for motor control applications	L6227Q
EVAL6228QR	L6228Q: Dual full bridge with PWM current control and translator for stepper reference design board	L6228Q
EVAL6393FB	Low voltage full bridge reference design board featuring L6393 advanced high-voltage gate driver	L6393

## FEATURED BOARD

**EVAL6393FB: Full Bridge Power Stage controlled by 2x L6393**

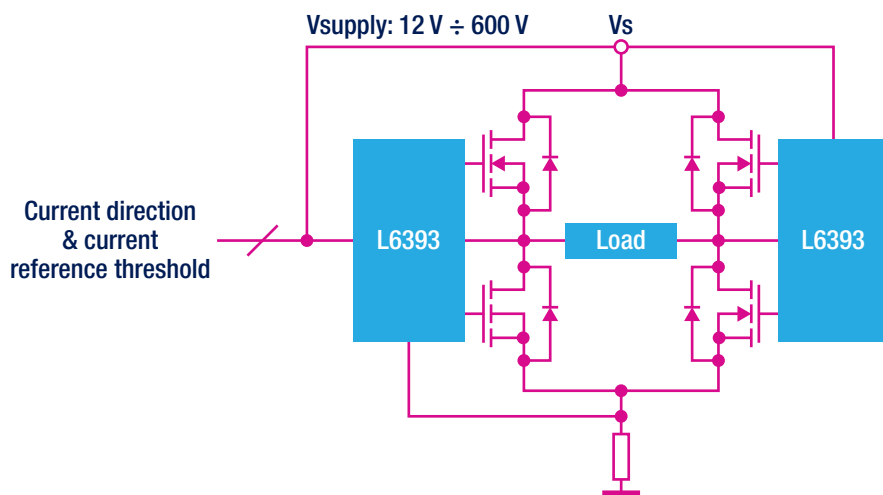

### KEY FEATURES

- Stand-alone solution:
  - Current direction & peak control by Phase/Brake inputs and embedded Comparators
  - No need of  $\mu$ CU or additional circuitry
- BOM cost saving:
  - Low component count
  - Lowest PCB occupation
- Very high flexibility
- Great EMI performance
- Full-Bridge evaluation board

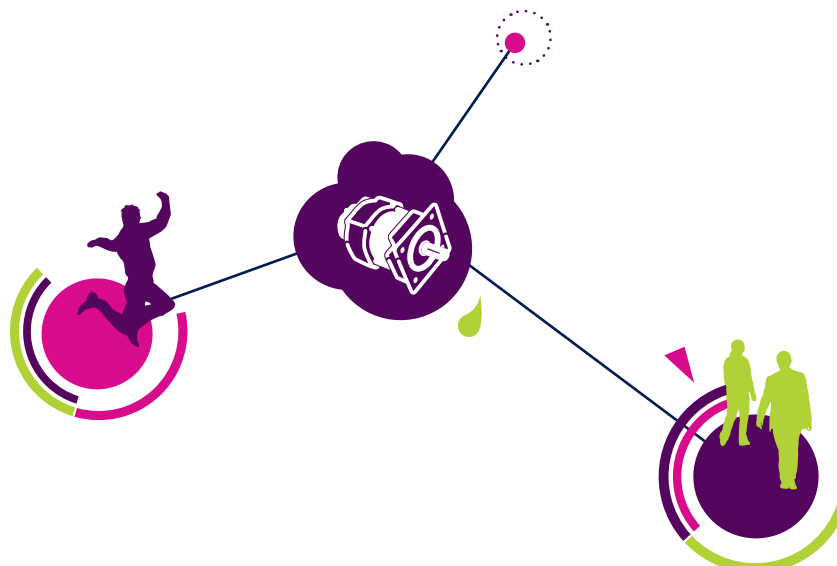
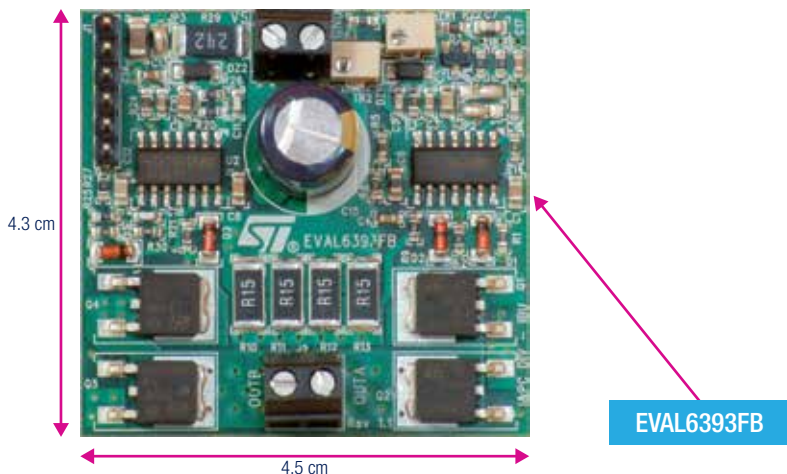



# Universal motor

## HIGH-FREQUENCY PWM

The pulse width modulation (PWM) technique (also known as a chopper drive) is used to adjust the voltage applied to the motor. With the variation of the Pulse duty cycle, the effective voltage seen by the motor can be changed. Compared to a phase-angle drive, a chopper drive requires a more complicated power stage with an input rectifier (if an AC mains is the source), a power switch and a fast power diode for motor current free-wheeling at switch-off. The advantage of PWM modulation with respect to phase-angle modulation is higher efficiency, less acoustic noise and better EMC behavior, but it can have an impact on the brush's duration.

## LOW-FREQUENCY DC

To improve the efficiency of universal motors, a DC control can be implemented. Indeed, applying a DC voltage to the motor will reduce the iron losses due to the eddy current. The easiest way to implement such a DC control is to use a Triac in series with the motor inside a diode bridge. The motor speed control is then still achieved with phase-control, thanks to a low-cost Diac circuit or with a low-end microcontroller. In this application, the rate of decrease of the Triac current is only limited by the mains spurious inductor, this is why an inductor has to be added in series with the AC switch. Using AC switches with a very high (di/dt) parameter allows this inductor size to be drastically reduced. The advantages versus a PWM drive control is increased robustness in regards to overvoltage, higher overcurrent capability and reduction of EMI noise due to high-frequency device switching.

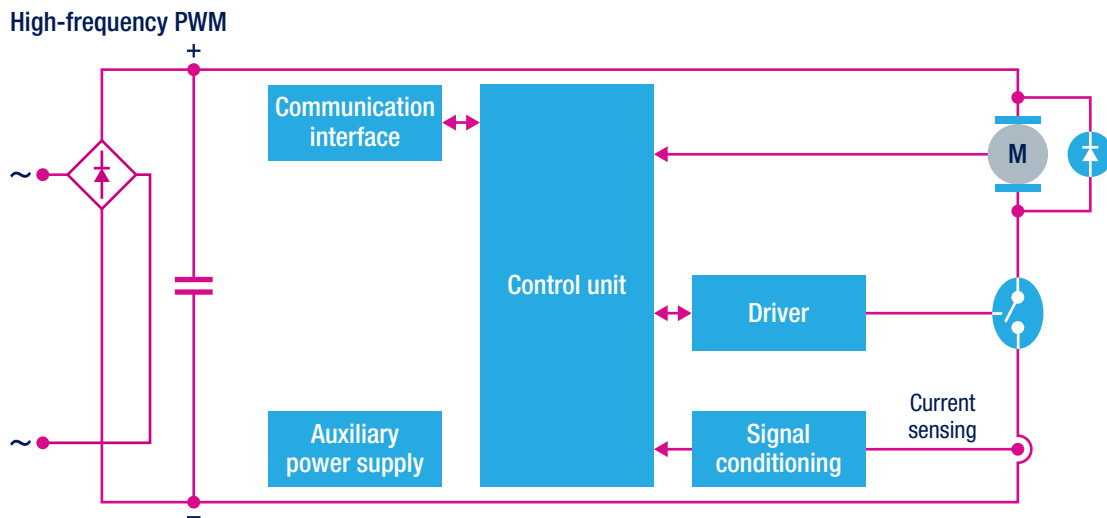
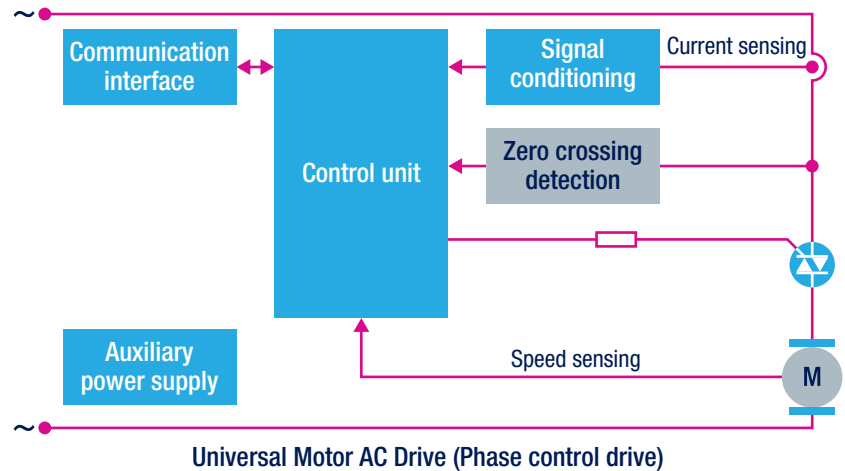
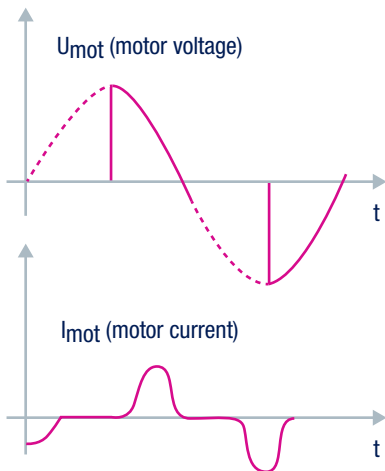

## KEY PRODUCTS

### TRIAC, ACS™ AND ACST FAMILIES

ST offers a complete range of thyristors and AC switches with voltage ratings up to 1200 V, current ratings up to 100 A and a set of packages from miniature surface-mounted packages to high power dissipation isolated and non-isolated packages.

The latest extension to the AC switches range features the SMB-Flat package, which is smaller than SOT-223 and is aimed at the 0.8 A device range. The PCB can be designed so that the SMB-Flat and SOT-223 are fully interchangeable for increased production flexibility.

#### Triacs

ST's portfolio of Triacs includes devices with voltage ratings up to 800 V and RMS on-currents up to 40 A in general-purpose standard configurations, a new high-commutation T series in Snubberless™ technology, and 3-quadrant high-temperature Triacs (H series) for use in harsh environments. They are the reference for universal and induction motor drivers in appliance applications where, due to their ability to manage the stringent inrush conditions when driving inductive loads, they can switch off three times their rating current.

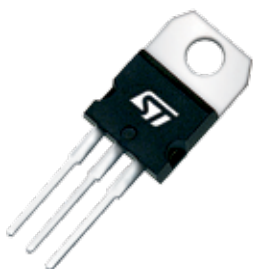

#### KEY FEATURES

- Robustness and reliability
- Wide voltage and current ranges
- Rich portfolio:
  - Standard Triacs
  - Snubberless™ with enhanced switch-off capability, for inductive loads
  - High-temperature T series for hot environments

	Part number	Packages	Current rating (A <sub>RMS</sub> )	Non repetitive surge peak on-state current (A)	Repetitive off-state voltage (V)	Operating Tj max (°C)	I <sub>GATE</sub> (mA)
T series	T435T-600FP	TO-220AB-FP	4	30	T435T-600FP: only 600 V	T435T-600FP: only 125 °C	35
	T635T	TO-220AB-Insulated 2500 V; TO-220AB-FP; TO-220AB	6	45			10, logic level, 3Q
	T8T		8	60			20/35, Snubberless™, 3Q
	T12T		12	90 - 100			25, standard, 4Q
	T16T		16	120			

	Part number	Packages	Current rating (A <sub>RMS</sub> )	Non repetitive surge peak on-state current (A)	V <sub>DRM</sub> - V <sub>RRM</sub> (V)	Operating Tj max (°C)	I <sub>GATE</sub> (mA)
H series	T410H	T0220	4	40	600	150	10
	T610H	T0220	6	60			10
	T8**H	T0220, D <sup>2</sup> PAK, TO-220I	8	80			10
	T10**H		10	100			35
	T12**H		12	120			50
	T16**H		16	160			35 50
	T20**H	20	200				
	T30**H	T0220, TO-220I	30	270			



## ACST™ and ACST

Using innovative ASD application-specific device technology, ST's ACST™ and ACST devices are specific switches developed for home appliances and industrial control applications.

While maintaining very high switch-off capability, logic-level devices allow direct drive by a microcontroller. With integrated overvoltage protection against random transients, no external MOV protection is needed, providing system safety and transient and surge voltage immunity as defined in the IEC 61000-4-4 and -4-5 standards. The ACST series is now extended from 2 A to 16 A, housed in TO-220AB and TO-220FP packages and the ACS series is also extended to 800 V with a lower gate triggering sensitivity of 5 mA.

### KEY FEATURES

- High switch off capability
- Low gate current for direct connection to MCU
- Internally protected, no need of external circuitry to meet IEC 61000-4-4 and -4-5 standards

Part number	Packages	Current rating (A <sub>RMS</sub> )	Non repetitive surge peak on-state current (A)	Repetitive off-state voltage (V)	Operating T <sub>J</sub> max (°C)	I <sub>GATE</sub> (mA)
ACST2	DPAK, TO-220FPAB	2	8	800	125	10
ACST4	DPAK, TO-220FPAB	4	30			10, 35
ACST6	D <sup>2</sup> PAK, TO220AB, TO-220FPAB	6	45			10
ACST8	D <sup>2</sup> PAK, TO220AB, TO-220FPAB	8	80			30
ACST10	TO220AB, TO-220FPAB	10	100	700	125	10, 35
ACST12	D <sup>2</sup> PAK, TO-220AB	12	120	700	125	10, 35
ACST1635-8FP	TO-220FPAB	16	140	800	150	35
ACS302	S020	0.2	7.3	600	125	5
ACS102-6T	S08, T092	0.2	7.3	600	125	5
ACS108	SOT223, T092	0.8	13.7	800	125	10
ACS110	SOT223	1	8	700	125	10
ACS120	DPAK, TO220AB, TO220FPAB	2	20	700	125	10
ACST1035-8FP	TO-220FPAB	10	90	800	150	35
ACST1235-8FP	TO-220FPAB	12	100	800	150	35

## EVALUATION TOOLS

Order code	Description	Technical documentation
STEVAL-IHM029V2	Universal motor control evaluation board based on high-temperature junction Triac and STM8S microcontroller	UM0922
STEVAL-IHM041V1	Universal motor driver with speed control based on the STM8 microcontroller and Triac (US version)	UM1559





# Single-phase AC induction

## Overview

With its proven experience, ST has become a well-recognized worldwide leader in the field of motor control. For the control of single-phase induction motors, ST offers a mix of innovative products, new topologies and state-of-art and rugged devices such as Triacs, Thyristors and AC switches.

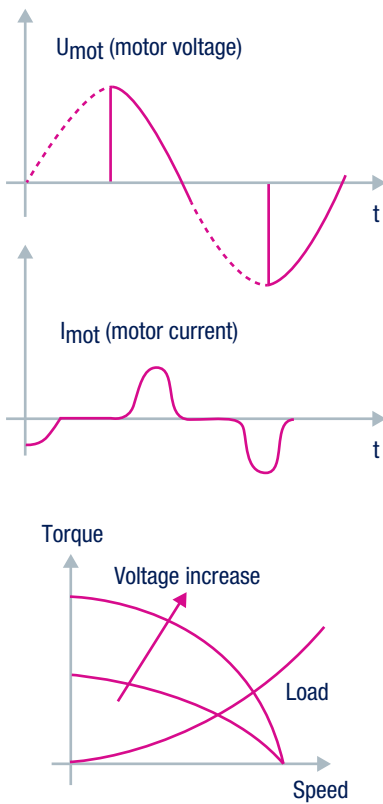

26

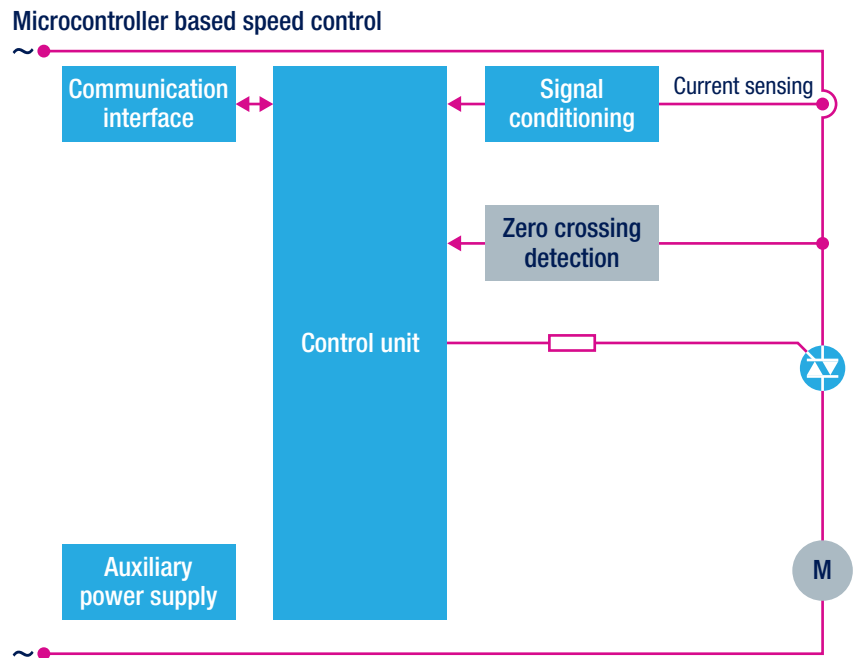

## KEY PRODUCTS

### TRIAC, ACS™ AND ACST FAMILIES

ST offers a complete range of thyristors and AC switches with voltage ratings up to 1200 V, current ratings up to 100 A and a set of packages from miniature surface-mounted packages to high power dissipation isolated and non-isolated packages.

The latest extension to the AC switch range features the SMB-Flat package, which is smaller than SOT-223 and is aimed at the 0.8 A device range. The PCB can be designed so that SMB-Flat and SOT-223 packages are fully interchangeable for increased production flexibility.

#### Triacs

ST's portfolio of Triacs includes devices with voltage ratings up to 800 V and RMS on-currents up to 40 A in general-purpose standard configurations, a new high commutation T series in Snubberless™ technology, and 3-quadrant high-temperature Triacs (H series) for use in harsh environments. They are the reference for universal and induction motor drivers in appliance applications where, due to their ability to manage the stringent inrush conditions when driving inductive loads, they can switch off three times their rating current.



#### KEY FEATURES

- Robustness and reliability
- Wide voltage and current ranges
- Rich portfolio:
  - Standard Triacs
  - Snubberless™ with enhanced switch-off capability, for inductive loads
  - High-temperature T series for hot environments

	Part number	Packages	Current rating (A <sub>RMS</sub> )	Non repetitive surge peak on-state current (A)	Repetitive off-state voltage (V)	Operating Tj max (°C)	I <sub>GATE</sub> (mA)
T series	T435T-600FP	TO-220AB-FP	4	30	600	125	35
	T635T	TO-220AB-Insulated 2500 V; TO-220AB-FP; TO-220AB	6	45	800	150	10, logic level, 3Q 20/35, Snubberless™, 3Q 25, standard, 4Q
	T8T		8	60	800	150	
	T12T		12	90 - 100	800	150	
	T16T		16	120	800	150	

	Part number	Packages	Current rating (A <sub>RMS</sub> )	Non repetitive surge peak on-state current (A)	V <sub>DRM</sub> - V <sub>RRM</sub> (V)	Operating Tj max (°C)	I <sub>GATE</sub> (mA)
High-temperature Triacs	T410H	TO-220	4	40	600	150	10
	T610H	TO-220	6	60			10
	T8**H	TO-220, D <sup>2</sup> PAK, TO-220I	8	80			10 35 50
	T10**H		10	100			
	T12**H		12	120			
	T16**H		16	160			
	T20**H	TO-220, TO-220I	20	200			35 50
	T30**H		30	270			

## ACST™ and ACST

Using innovative ASD application-specific device technology, ST's ACST™ and ACST devices are specific switches developed for home appliances and industrial control applications.

While maintaining very high switch-off capability, logic-level devices allow direct drive by a microcontroller. With integrated overvoltage protection against random transients, no external MOV protection is needed, providing system safety and transient and surge voltage immunity as defined in the IEC 61000-4-4 and -4-5 standards. The ACST series now extends from 2 A to 16 A, housed in TO-220AB and TO-220FP packages, and the ACS series is also extended to 800 V with a lower gate triggering sensitivity of 5 mA.

### KEY FEATURES

- High switch off capability
- Low gate current for direct connection to MCU
- Internally protected, no need of external circuitry to meet IEC 61000-4-4 and -4-5 standards

Part number	Current rating (A <sub>RMS</sub> )	Non repetitive surge peak on-state current (A)	Repetitive off-state voltage (V)	Operating T <sub>j</sub> max (°C)	I <sub>GATE</sub> (mA)	Packages
ACST2	2	8	800	125	10	DPAK, TO-220FPAB
ACST4	4	30			10, 35	DPAK, TO-220FPAB
ACST6	6	45			10	D <sup>2</sup> PAK, TO-220AB, TO-220FPAB
ACST8	8	80			30	D <sup>2</sup> PAK, TO-220AB, TO-220FPAB
ACST10	10	100	700	125	10, 35	TO-220AB, TO-220FPAB
ACST12	12	120	700	125	10, 35	D <sup>2</sup> PAK, TO-220AB
ACST1635-8FP	16	140	800	150	35	TO-220FPAB
ACS302-6T	0.2	7.3	600	125	5	S020
ACS102-6T	0.2	7.3	600	125	5	S08, T092
ACS108	0.8	13.7	800	125	10	SOT223, T092
ACS110	1	8	700	125	10	SOT223
ACS120	2	20	700	125	10	DPAK, TO-220AB, TO-220FPAB
ACST1035-8FP	10	90	800	150	35	TO-220FPAB
ACST1235-8FP	12	100	800	150	35	TO-220FPAB

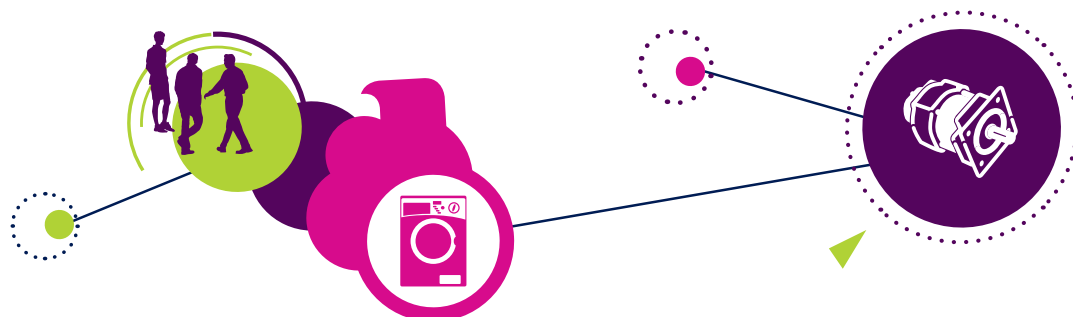

## IGBTs

ST introduces a new IGBTs family developed using an advanced proprietary trench gate and field stop structure.

The devices are part of the 600 V “H” series which represent an optimum compromise between conduction and switching losses to maximize the efficiency of high switching frequency.

This new series combines a very low saturation voltage (down to 1.6 V) with a minimal collector current turn-off and a maximum junction operating temperature of 175 °C.

### KEY FEATURES

- Low  $V_{CE(SAT)}$  for reduced conduction losses
- Short-circuit rugged
- Co-packaged tailored anti-parallel diode option for improved power dissipation and best thermal management
- Negative temperature derating of  $V_{CE(SAT)}$
- Several package options

Collector emitter voltage max (V)	Part number	$I_{CN}$ collector current max @ 100 °C (A)	$V_{CE(SAT)}$ ( $I_{CN}$ @ $T_J = 25$ °C) (V)	Short-circuit rugged	Packages
600	STG*5H60(D)F	5	1.50	Yes	D <sup>2</sup> PAK, DPAK, TO220FP, TO220
	STG*7H60(D)F	7	1.50	Yes	D <sup>2</sup> PAK, TO220FP, TO220
	STG*10H60(D)F	10	1.50	Yes	D <sup>2</sup> PAK, TO220FP, TO220
	STG*15H60(D)F	15	1.50	Yes	D <sup>2</sup> PAK, TO220FP, TO220
	STG*20H60(D)F	20	1.50	Yes	D <sup>2</sup> PAK, TO220FP, TO220, TO247

## Diodes and rectifiers

ST's ultrafast diodes range from 300 V to 1200 V with various Vf/trr and Qrr/S factor trade-offs so as to achieve the best performance for any application, including high-frequency AC chopping topology for single-phase AC induction motors. The Turboswitch™ diodes feature ultra-fast recovery while maintaining a low drop voltage. They significantly cut losses in both the diode and the transistor at turn-on.

All ST products are rated up to 175 °C operating junction temperature, as a result of the reduced leakage currents. Low-profile PowerFLAT™ packages are also available.

### KEY FEATURES

- Wide voltage range from 300 V to 1200 V
- Up to 200 A current range
- Low-profile PowerFLAT™ packages
- Different Vf/trr trade-offs available in different packages
- 175 °C operating junction temperature

	Part number	Average rectified current max (A)	Forward voltage max (@ If) spec (V)	Reverse <sup>1</sup> recovery charges (Qrr) typ (nC)	S factor typ	Package
300 V ultrafast rectifiers	STTH8R03	8	1.8	60	0.4	TO-220AC
	STTH8R03DJF	8	1	120	0.3	PowerFLAT™ 5 x 6
	STTH30R03	30	1.4	63	0.4	D <sup>2</sup> PAK, TO-247
400 V ultrafast rectifiers	STTH8R04	8	1.5	148	0.4	D <sup>2</sup> PAK, TO-220AC, TO-220AC Ins
	STTH20R04	20	1.7	225	0.3	D <sup>2</sup> PAK, TO-220AC, DO-247, TO-220FPAC
	STTH30R04	30	1.45	525	0.4	D <sup>2</sup> PAK, TO-220AC, DO-247, DOP3 Ins
600 V ultrafast rectifiers	STTH5R06	5	2.9	110	0.35	D <sup>2</sup> PAK, TO-220AC, DPAK, TO-220FPAC
	STTH5R06DJF	5	1.2	180	0.5	PowerFLAT™ 5 x 6
	STTH8R06	8	2.9	150	0.3	D <sup>2</sup> PAK, TO-220AC, TO-220AC Ins, I <sup>2</sup> PAK, TO-220FPAC
	STTH12R06	12	2.9	180	0.2	D <sup>2</sup> PAK, TO-220AC
	STTH15R06	15	2.9	220	0.15	TO-220AC, TO-220FPAC
	STTH30R06	30	1.85	1000	0.37	DO-247, DOP3 Ins

Note: 1. See datasheet for testing conditions.

### Gate drivers solution for IGBTs and MOSFETs

ST's power MOSFET and IGBT gate drivers include integrated half-bridge, single and multiple low-side gate drivers and galvanically isolated device. ST's MOSFET/IGBT drivers provide state-of-the-art integration, reducing BOM cost and final application dimensions, while also increasing robustness and noise immunity.

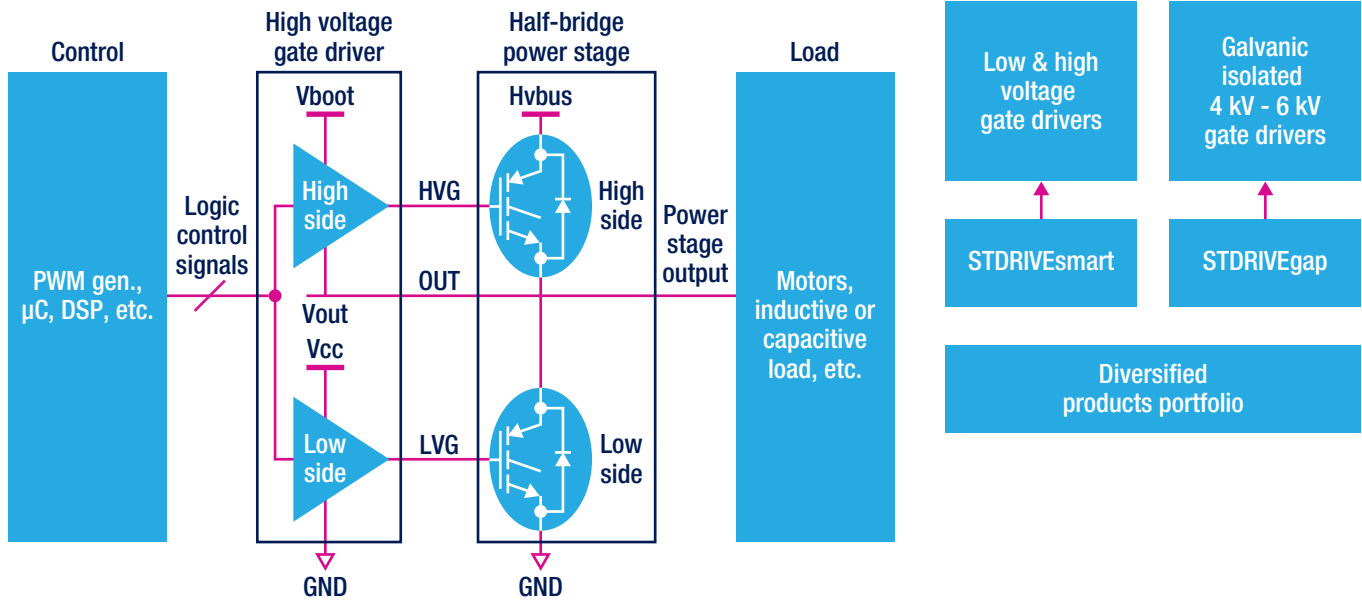

### EVALUATION TOOLS

ST proposes a wide range of evaluation boards for comprehensive evaluation of ST's products and solutions while reducing your development time.

Order code	Description	Technical documentation
STEVAL-IHT001V2	Cold thermostat kit based on AC switches and the STM8S	UM1542
STEVAL-IHT007V1	Extension board with ACS for STM8S-Discovery kit	UM1494
STEVAL-IHM029V2	Universal motor control evaluation board	UM0922
STEVAL-IHM041V1	Universal motor driver with speed control based on the STM8 and Triac (US version)	UM1559





# Switched reluctance motors

## Overview

Switched reluctance motors are mainly used in traction, industrial and automotive pumps and home appliances (vacuum cleaners and certain washing machines). Their structure is similar to that of stepper motors but switched reluctance motors have fewer magnetic poles. Despite their simple structure, external electronic commutation is needed.

The asymmetrical half-bridge PWM drive leverages the motor's best features. An independent current loop is implemented for each motor phase so that some phase current overlap is possible to attain higher speeds. For the drive,  $2 \times n$  power switches are required ( $n$  being the number of motor phases). The simplified asymmetrical half-bridge PWM drive topology only requires  $n + 1$  power switches and is well adapted to medium-speed operation.

ST has developed specific products to better address both configurations. A general-purpose 8-bit microcontroller such as the STM8S can be generally used to drive a switched reluctance motor, although an entry-level STM32 may be more suited for higher performance.

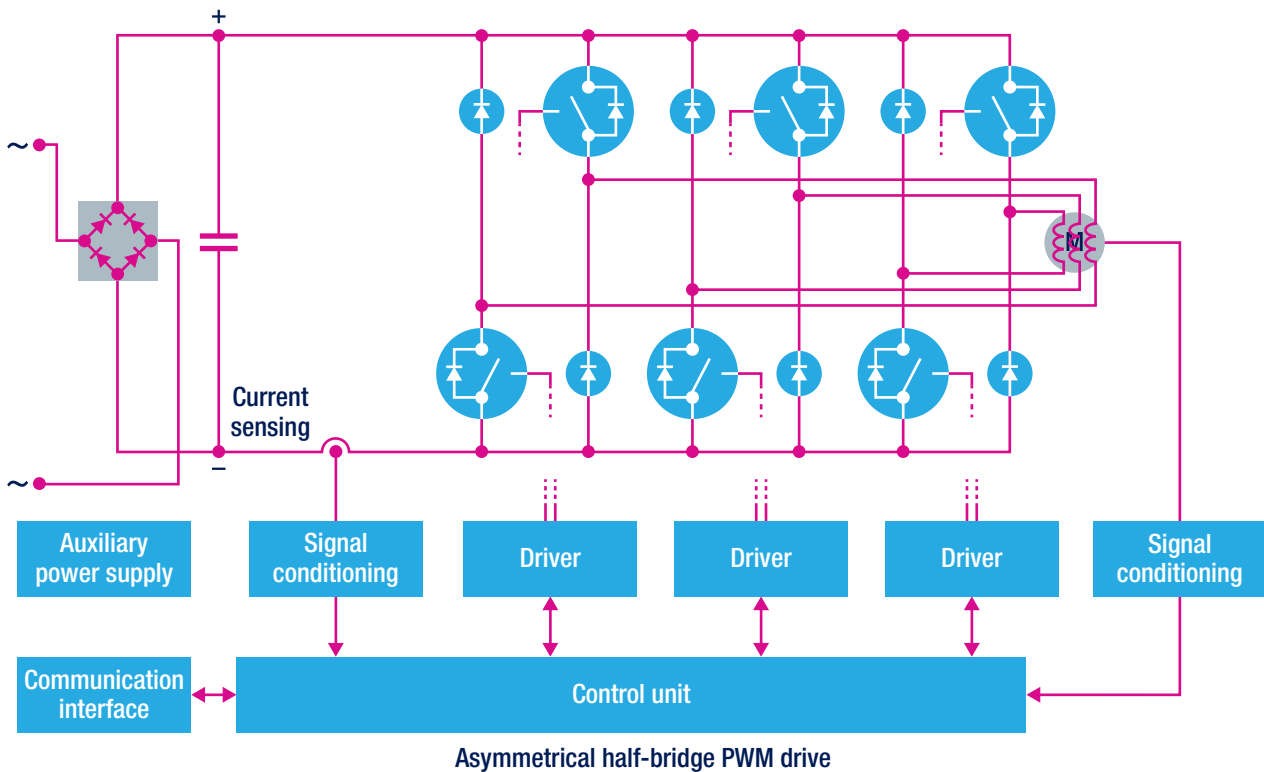

## KEY PRODUCTS POWER SWITCHES

### IGBTs

The ST offers IGBTs with breakdown up to 650 V.

These IGBTs have been developed using an advanced proprietary trench gate and field stop structure.

The series combine a very low saturation voltage with a minimal collector current turn-off and a maximum junction operating temperature of 175 °C.

The 600 V “H” series represents an optimum compromise between conduction and switching losses to maximize the efficiency of medium to high frequency inverters.

The 650 V “M” series represents an optimum compromise in performance to maximize the efficiency of industrial motor drives systems where low-loss and high short-circuit capability are essential.

### KEY FEATURES

- Low VCE(SAT) for reduced conduction losses
- Improved switch-off energy spread versus temperature for reduced switching losses
- Co-packaged tailored anti-parallel diode option for improved power dissipation and best thermal management
- Negative temperature derating of VCE(SAT)
- Several package options

Collector emitter voltage max (V)	Part number	$I_{CN}$ collector current max @ 100 °C (A)	$V_{CE(SAT)}$ ( $I_{CN}$ @ $T_J = 25$ °C) (V)	Short-circuit rugged	Packages
600	STG*5H60(D)F	5	1.45	Yes	D <sup>2</sup> PAK, DPAK, T0220FP, T0220
	STG*7H60(D)F	7	1.50	Yes	D <sup>2</sup> PAK, T0220FP, T0220
	STG*10H60(D)F	10	1.50	Yes	D <sup>2</sup> PAK, T0220FP, T0220
	STG*15H60(D)F	15	1.60	Yes	D <sup>2</sup> PAK, T0220FP, T0220
	STG*20H60(D)F	20	1.60	Yes	D <sup>2</sup> PAK, T0220FP, T0220, T0247
650	STG*4M65DF2 <sup>1</sup>	4	1.5	Yes	D <sup>2</sup> PAK, DPAK, T0220FP, T0220
	STG*6M65DF2 <sup>1</sup>	6	1.5	Yes	D <sup>2</sup> PAK, DPAK, T0220FP, T0220
	STG*10M65DF2	10	1.55	Yes	D <sup>2</sup> PAK, T0220FP, T0220
	STG*15M65DF2 <sup>1</sup>	15	1.55	Yes	D <sup>2</sup> PAK, T0220FP, T0220
	STG*20M65DF2 <sup>1</sup>	20	1.55	Yes	D <sup>2</sup> PAK, T0220FP, T0220
	STG*30M65DF2	30	1.65	Yes	D <sup>2</sup> PAK, T0220FP, T0220, T0247LL

Note: 1. Available Q4'15



## Diodes and rectifiers

ST's ultrafast diodes range from 300 V to 1200 V with various  $V_F/T_{rr}$  and  $Q_{rr}/S$  factor trade-offs so as to achieve the best performance for any application. Turboswitch™ diodes feature ultrafast recovery while maintaining a low drop voltage. They significantly cut losses in both the diode and the transistor at turn-on.

All ST products are rated up to 175 °C operating junction temperature, as a result of the reduced leakage currents.

Low-profile PowerFLAT™ package are also available.

### KEY FEATURES

- Wide voltage range from 300 V to 1200 V
- Up to 200 A current range
- Low-profile PowerFLAT™ packages
- Different  $V_F/T_{rr}$  trade-offs available in different packages
- 175 °C operating junction temperature

	Part number	Average rectified current max (A)	Forward Voltage max (@ IF) spec (V)	Reverse <sup>1</sup> recovery charges (Qrr) typ (nC)	S factor typ	Package
300 V ultrafast rectifiers	STTH8R03	8	1.8	60	0.4	TO-220AC
	STTH8R03DJF	8	1	120	0.3	PowerFLAT™ 5 x 6
	STTH30R03	30	1.4	63	0.4	D <sup>2</sup> PAK, TO-247
400 V ultrafast rectifiers	STTH8R04	8	1.5	148	0.4	D <sup>2</sup> PAK, TO-220AC, TO-220AC Ins
	STTH20R04	20	1.7	225	0.3	D <sup>2</sup> PAK, TO-220AC, DO-247, TO-220FPAC
	STTH30R04	30	1.45	525	0.4	D <sup>2</sup> PAK, TO-220AC, DO-247, DOP3 Ins
600 V ultrafast rectifiers	STTH5R06	5	2.9	110	0.35	D <sup>2</sup> PAK, TO-220AC, DPAK, TO-220FPAC
	STTH5R06DJF	5	1.2	180	0.5	PowerFLAT™ 5 x 6
	STTH8R06	8	2.9	150	0.3	D <sup>2</sup> PAK, TO-220AC, TO-220AC Ins, I <sup>2</sup> PAK, TO-220FPAC
	STTH12R06	12	2.9	180	0.2	D <sup>2</sup> PAK, TO-220AC
	STTH15R06	15	2.9	220	0.15	TO-220AC, TO-220FPAC
	STTH30R06	30	1.85	1000	0.37	DO-247, DOP3 Ins

Note: 1. See datasheet for testing conditions





# Power factor correctors

## Overview

ST features products for the two main topologies used for power factor correction associated to motor control applications.

A single-stage boost converter is the most used topology for PFC. ST's portfolio supports both the solution using an integrated PFC controller with external power switch and the topology where the PFC control is executed by a microcontroller and the power switch actuation through a gate driver.

Above 2 kW, an interleaved PFC may be more convenient. Despite a higher number of components, it allows better heat dissipation and smaller silicon devices, reduces input current ripple and RMS current in the bus capacitor and finally helps in reducing the dimension of the filter.

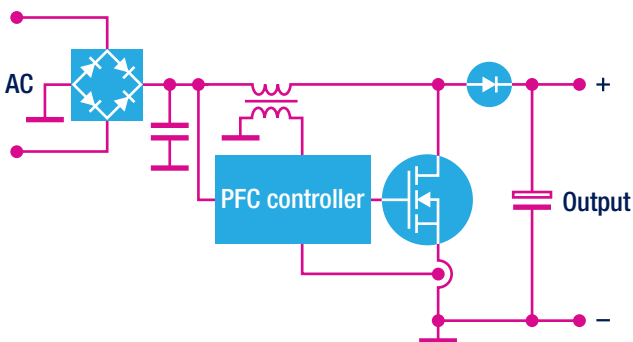

Single stage boost converter PFC

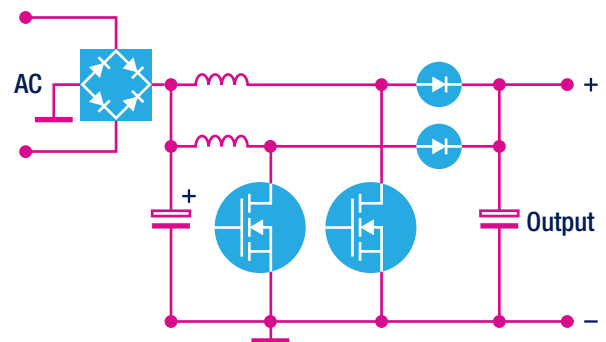

2 phase interleaved PFC

34

## KEY PRODUCTS POWER SWITCHES

### IGBTs

ST offers for mono and three-phase inputs the IGBTs families at 650 V and 1200 V developed using an advanced proprietary trench gate and field stop structure.

The devices represent an optimum compromise between conduction and switching losses to maximize the efficiency of high switching frequency.

This new series combines a low saturation voltage with a minimal collector current turn-off and a maximum junction operating temperature of 175 °C.

Moreover, a positive  $V_{CE(sat)}$  temperature coefficient and very tight parameter distribution result in safer paralleling operation.

Collector emitter voltage max (V)	Part number	$I_{CN}$ collector current max @ 100 °C (A)	$V_{CE(sat)}$ ( $I_{CN}$ @ $T_J = 25$ °C) (V)	Short-circuit rugged	Packages
650	STG*20H65FB	20	1.55	Yes	T0247, T03P, T03PF
	STG*30H65(D)FB	30	1.55	Yes	T0247, T03P, T03PF
	STG*40H65(D)FB	40	1.60	Yes	T0247, T03P, T03PF
650	STG*15H120DF2	15	2,10	Yes	T0247, T0-247LL
	STG*25H120DF2	25	2,10	Yes	T0247, T0-247LL
	STG*40H120DF2	40	2,10	Yes	T0247, T0-247LL, T0-247 MAX

## Power MOSFETs

ST's MOSFET portfolio offers a broad range of breakdown voltages from 500 V to 650 V, with low gate charge and low on-resistance, combined with state-of-the-art packaging. ST's process technology for both high-voltage and low-voltage MOSFETs has enhanced power handling capability, resulting in high-efficiency solutions.

MDmesh™ M5, MDmesh™ II and MDmesh™ M2 families of power MOSFETs are particularly suitable for PFC circuits.

	Part number	$V_{DSS}$ (V)	$R_{DS(on)}$ max @ 10 V ( $\Omega$ )	Drain current max (A)	Qg (nC)	Package
More than 50 kHz	STY105NM50N	500	0.022	110	326	Max247
	STW60NM50N	500	0.043	68	178	T0247
	ST*36N55M5	550	0.08	33	72	T0220, T0220FP, D <sup>2</sup> PAK
	ST*18N55M5	550	0.192	16	31	T0220, T0220FP, D <sup>2</sup> PAK, DPAK
	STY100NM60N	600	0.029	98	330	Max247
	STW70N60M2	600	0.04	68	110	T0247
	STW62NM60N	600	0.049	65	174	T0247
	STW48NM60N	600	0.07	39	130	T0247
	ST*40N60M2	600	0.088	34	75	T0220, T0220FP, D <sup>2</sup> PAK, I <sup>2</sup> PAK, I <sup>2</sup> PAKFP, T0247
	ST*33N60M2	600	0.12	26	47	T0220, T0220FP, D <sup>2</sup> PAK, I <sup>2</sup> PAK, T0247, PowerFLAT 8x8 HV
	ST*28N60M2	600	0.15	22	39	T0220, T0220FP, D <sup>2</sup> PAK, I <sup>2</sup> PAK, T0247
	ST*24N60M2	600	0.19	18	29	T0220, T0220FP, D <sup>2</sup> PAK, I <sup>2</sup> PAKFP, I <sup>2</sup> PAK, T0247, PowerFLAT 8x8 HV
	STY145N65M5	650	0.015	139	414	Max247
	STY139N65M5	650	0.017	130	363	Max247
	ST*88N65M5	650	0.029	84	204	T0247
	STW69N65M5	650	0.045	58	153	T0247, T03P
	ST*57N65M5	650	0.063	42	110	T0220, T0220FP, D <sup>2</sup> PAK, I <sup>2</sup> PAK, T0247
	ST*20NM65N	650	0.25	19	44	I <sup>2</sup> PAK
	ST*15NM65N	650	0.35	13	40	I <sup>2</sup> PAK, T0220FP
	ST*11NM65N	650	0.41	11	30	T0220, T0220FP, DPAK

## Diodes and rectifiers

ST offers ultrafast, Tandem™ and silicon carbide (SiC) rectifier solutions for all market requirements.

Our SiC and ultrafast diodes range from 600 V to 650 V with various  $V_F/T_{rr}$ , QC trade-offs so as to achieve the best performance for your PFC application.

For power converter applications where silicon diodes reach the limits of their operating temperature and power density, ST's first and second generation silicon carbide devices offer optimal reliability and performance.

All ST products are rated up to 175 °C operating junction temperature, as a result of the reduced leakage currents.

### PACKAGING OPTIONS

- Single diode for conventional PFC  
Dual common cathode for interleaved configuration
- T0247 with longer leads facilitate bending and heat-sink assembly
- T03P facilitates the mounting of plastic frames

	Part number	Average rectified current max (A)	Forward voltage ( $V_F$ ) max (V)	$V_F$ measuring condition (A)	Reverse recovery time max (ns)	Reverse current max (mA)	Package
600 V ultrafast rectifiers	STTH8R06	8	2.9	8	25	0.025	D <sup>2</sup> PAK; T0-220AC; T0-220AC Ins; I <sup>2</sup> PAK; T0-220FPAC
	STTH12R06	12	2.9	12	25	0.045	D <sup>2</sup> PAK; T0-220AC; T0-220AC Ins
	STTH15R06	15	2.9	15	30	0.06	T0-220AC; T0-220FPAC
	STTH30R06	30	1.85	30	50	0.025	DO-247; DOP3 Ins

	Part number	Average rectified current max (A)	Forward voltage ( $V_F$ ) max (V)	$V_F$ measuring condition (A)	Reverse recovery time max (ns)	Reverse' recovery current max (A)	Package
600 V hyper-fast Tandem rectifiers	STTH8T06DI	8	2.55	8	28	3	TO-220AC Ins
	STTH12T06DI	12	2.55	12	30	3	TO-220AC Ins
	STTH8S06D	8	3.1	8	20	TBD	TO-220AC Ins

Note: 1. See datasheet for testing conditions

	Part number	Average rectified current max (A)	Forward voltage ( $V_F$ ) max (V)	$V_F$ measuring condition (A)	Total capacity charge typ <sup>1</sup> (nC)	Package
600 V low $V_F$ SiC diodes	STPSC606	6	1.7	6	6	D <sup>2</sup> PAK; TO-220AC
	STPSC806	8	1.7	8	10	D <sup>2</sup> PAK; TO-220AC
	STPSC1006	10	1.7	10	12	D <sup>2</sup> PAK; TO-220AC
	STPSC1206	12	1.7	12	12	TO-220AC
	STPSC2006C	2 x 10	1.7	10	12	TO-247
650 V high $I_{FSM}$ SiC diodes	STPSC40065C	2 x 20	1.7	20	42	TO-247
	STPSC6H065	6	1.75	6	18	D <sup>2</sup> PAK; TO-220AC; DPAK
	STPSC8H065	8	1.75	8	23.5	D <sup>2</sup> PAK, DPAK, TO-220AC
	STPSC10H065	10	1.75	10	28.5	D <sup>2</sup> PAK, TO-220AC, DPAK
	STPSC12H065	12	1.75	12	18	D <sup>2</sup> PAK, TO-220AC, DPAK
	STPSC20H065C	2 x 10	1.75	10	28.5	TO-220, TO-247

Note: 1. See datasheet for testing conditions

### PFC controllers

The new L4984 is a current-mode PFC controller operating with line-modulated fixed-off-time (LM-FOT) control. A proprietary LM-FOT modulator allows fixed-frequency operation for boost PFC converters as long as they are operated in CCM (continuous conduction mode).

The chip comes in a 10-pin SO package and offers a low-cost solution for CCM-operated boost PFC pre-regulators in EN61000-3-2 and JEIDA-MITI compliant applications, in a power range that spans from a few hundred watts to 1 kW and above.

A software design tool based on an Excel spreadsheet is available.

Part number	Description	Package
L4984	Current-mode PFC controller	SO10

### KEY FEATURES

- Current continuous mode FOT
- Adjustable overvoltage protection on  $V_{OUT}$  (unlatched)
- Inductor saturation protection (unlatched)
- Open loop protection
- Input mains undervoltage detection
- Soft start-up for in-rush current limiting
- THD improver
- Remote on/off control input pin
- Small package
- 150 °C operating junction temperature



## Gate drivers for IGBTs and MOSFETs

ST's power MOSFET and IGBT drivers include integrated high-voltage half-bridge, single and multiple low-side gate drivers. ST's MOSFET/IGBT drivers provide state-of-the-art integration, reducing BOM cost and final application dimensions, while also increasing robustness and noise immunity.

The TD35x and TD2xx are the two families of single-channel gate drivers featuring an innovative active Miller clamp function which eliminates the need for negative gate drive in most applications and allows the use of a simple bootstrap supply for the high-side driver.

The TD350E, in particular, is an innovative gate driver where control and protection functions are included and allow the design of highly-reliable systems.

The innovative active Miller clamp function eliminates the need for negative gate drive in most applications and allows the use of a simple bootstrap supply for the high-side driver.

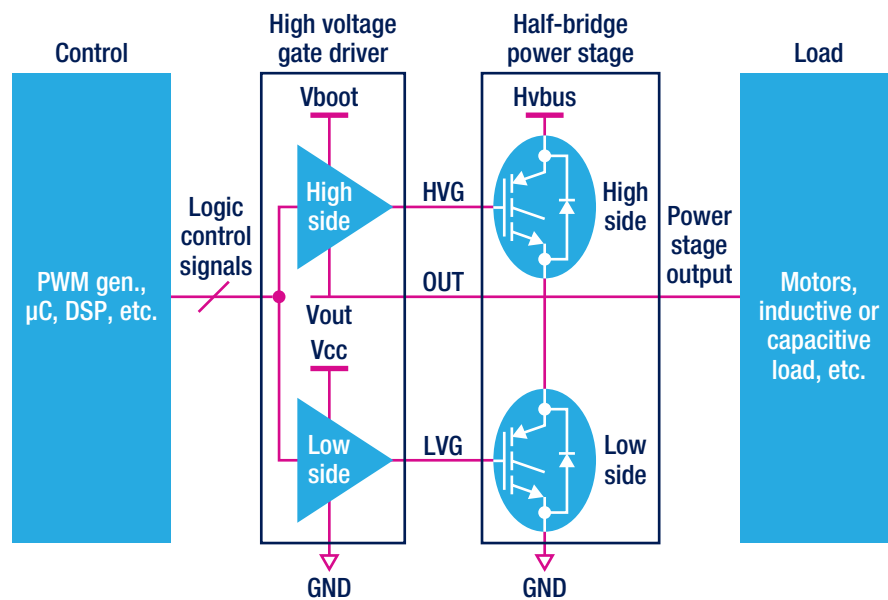

### KEY FEATURES

- Half-bridge, single-channel and multichannel gate drivers
- State-of-the-art integration thanks to:
  - HV bootstrap diode
  - Op amp
  - Comparator
  - Smart shutdown
  - Undervoltage lock out (UVLO)
  - Programmable deadtime

Part number	Logic interface		$V_{cc}$ max (V)	UVLO on $V_{cc}$ (V)	Op Amp	Comparator	# Pins
	Configuration	Compatibility					
TD350	Single channel (opto/pulse transformer compatible)	5 V	26	11	No	No	14
TD351	Single channel (opto/pulse transformer compatible)	5 V	26	11	No	No	8
TD352	Single channel (opto compatible)	5 V	26	11	No	No	8
TD220	Single channel	3.3, 5 V	17	8	No	No	8
TD221	Single channel	3.3, 5 V	12	8	No	No	8
TD310	Triple channel	3.3, 5 V	18	12	Yes	Yes	16

## EVALUATION TOOLS

Order code	Description	Technical documentation
EVL4984-350W	350 W CCM PFC pre-regulator demonstration board based on L4984	AN4163



# Microcontrollers

## Microcontrollers portfolio

ST's product portfolio contains a comprehensive range of microcontrollers, from robust, low-cost 8-bit MCUs, the STM8 family, up to 32-bit ARM®-based Cortex®-M0/M0+, Cortex®-M3, Cortex®-M4, Cortex®-M7 Flash microcontrollers with a rich choice of peripherals, the STM32 family.

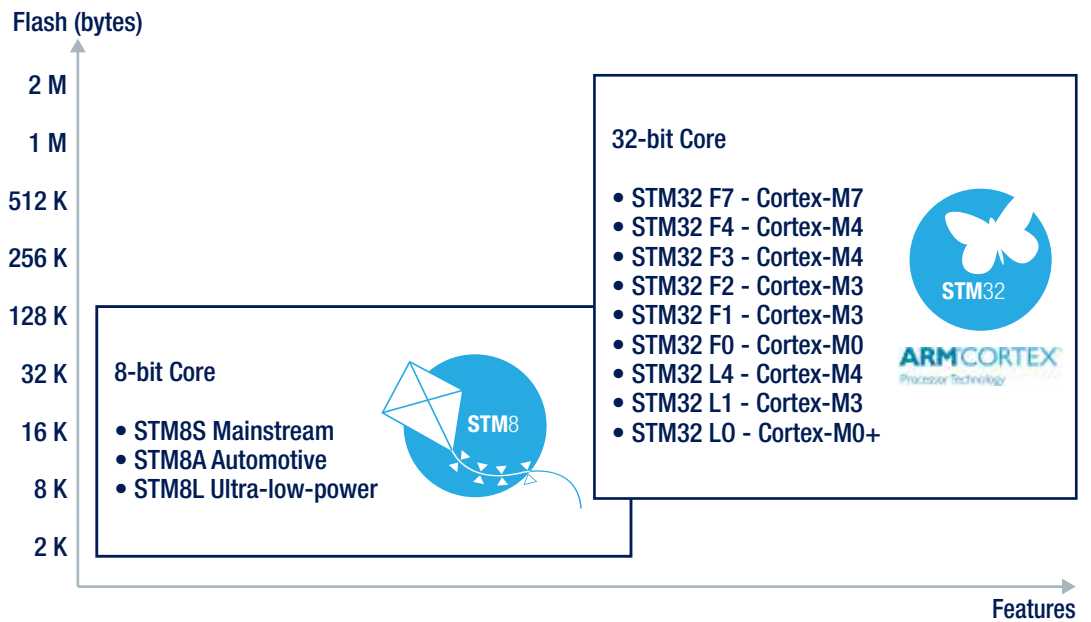

## KEY MCU SELECTION GUIDE FOR MOTOR CONTROL

Motor	STM8S	STM32F0 STM32F1	STM32F3 STM32F1	STM32F4 STM32F7
Brushed DC motors	X	X		
Single-phase AC induction motors	X	X		
Stepper motors	X	X		
Switched reluctance motors	X	X	X	
3-phase brushless motors	X	X	X	X
Universal motors	X	X		
PFC		X	X	X

**STM8S:**  
Brushed DC motors  
Single-phase AC induction motors  
Universal Motors



**STM8S, STM32:**  
Stepper motors  
Switched reluctance motors  
3-phase brushless motors

## STM8 8-BIT MICROCONTROLLERS

The STM8 MCU is part of a platform of technologies, IPs and tools which forms the basis of ST's comprehensive family of 8-bit microcontrollers. These cover, among others, many applications where there is an electric motor, from consumer electronics, including home appliances and factory automation, to automotive segments. The platform provides outstanding levels of digital and analog performance combined with a high level of cost effectiveness.

Implemented around a high-performance 8-bit core and a state-of-the-art set of peripherals and IPs, the microcontrollers in the STM8 family are manufactured using an ST-proprietary 130 nm embedded non-volatile memory technology.

### One series for every need

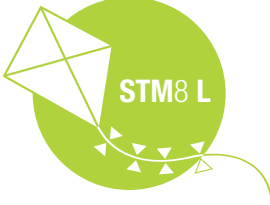
<p><b>STM8S</b> Mainstream</p>  <ul style="list-style-type: none"> <li>• Data EEPROM</li> <li>• 3 and 5 V families</li> <li>• Precise RC</li> </ul> <p><b>Best market value</b></p> <p>Robust and reliable Up to 125 °C</p>	<p><b>STM8A</b> Automotive</p>  <ul style="list-style-type: none"> <li>• Data EEPROM</li> <li>• 3 and 5 V families</li> <li>• Precise RC</li> <li>• LIN, CAN</li> <li>• Grade 0</li> </ul> <p><b>Long term guarantee</b></p> <p>AEC-Q100 Up to 150 °C</p>	<p><b>STM8L</b> Ultra-low-power</p>  <ul style="list-style-type: none"> <li>• Data EEPROM</li> <li>• 1.65 and 3 V families</li> <li>• Strong analog</li> <li>• LCD drivers</li> <li>• Low leakage technology</li> </ul> <p><b>Low-power performance and features</b></p> <p>High en analog IPS Active halt &lt;1 µA</p>
--	--	--

### Using STM8's peripherals for motor control

The STM8 comes with a set of peripherals that are suitable for many motor control topologies and applications.

The advanced timer available on the STM8S, STM8L and STM8A is a 16-bit timer capable of both centered or edge-aligned PWM pattern generation and, thanks to the availability of complimentary output on 3 of its channels, is specifically designed to address 3-phase and full-bridge topologies (for 3-phase AC IM, 3-phase PMSM/BLDC, bidirectional DC motors, stepper motor drives). The timer is also equipped with a synchronization circuit allowing the ADC to be triggered on specific events and an asynchronous emergency input.

The 12-bit ADC of the STM8L (10-bit on the STM8S and STM8A) allows motor current and voltage to be precisely sensed while its comparator could be used for hysteresis peak current control.

General-purpose 16-bit timers with their input capture capabilities are very well suited for motor speed feedback processing. In particular, the STM8L also features three input XOR gates combining the data coming from three Hall sensors to simplify speed measurement in 3-phase permanent magnet motors.

### KEY FEATURES

- Advanced timer for 3-phase inverters and full-bridge converter drivers
- Fast and precise ADC can be triggered by timer events
- 5 V power supply
- Input capture on general-purpose timers for easier speed feedback processing
- Encoder operating mode only for DC motors

## STM8S EVALUATION TOOLS FOR MOTOR CONTROL

Order code	Description	Motors covered	Documentation
STM8/128-MCKIT	3-phase brushless motor control starter kit for STM8S microcontroller	3-phase brushless motors: AC IM, BLDC, PMSM	UM0709
STM8/128-EVAL	STM8S MCU evaluation board; any motor control power stage featuring ST's standard MC connector can be connected (see 3-phase brushless motor evaluation tools section)	Depends on power stage connected through MC connector <sup>1</sup>	UM0482
STEVAL-IHM029V2	Universal motor control evaluation board based on high-temperature junction Triac and STM8S microcontroller	Universal, single-phase Induction motors	UM0922
STEVAL-IHM041V1	Universal motor driver with speed control based on the STM8 microcontroller and Triac (US version)	Universal, single-phase induction motors	UM1559
STEVAL-IFN004V1	BLDC six-step motor driver based on L6230 motor driver and STM8S105 microcontroller	3-phase BLDC/PMSM motors	UM1477
STEVAL-IHT001V2	Cold digital thermostat kit	Single-phase induction motors	UM1542

Note: 1. A daughter board may be required to be plugged on STM8/128-EVAL depending on the type of the control and power stage to be connected



### STM8/128-MCKIT STARTER KIT

STM8/128-MCKIT is an integrated system designed to provide a complete, ready-to-use kit for evaluation of 3-phase motor control developed around ST's STM8 microcontroller.

This starter kit is particularly suited to drive 3-phase brushless motors (either AC induction or permanent magnet types).

Download for free from [www.st.com](http://www.st.com) the available FW library, configure it through STM8 MC Builder PC software and develop your own applications in conjunction with a third-party IDE and C compiler.

### 3-PHASE BRUSHLESS MOTOR CONTROL WITH STM8S IN 3 STEPS:

1. Visit [www.st.com](http://www.st.com) to download STM8S FW library for 3-phase motor control
2. Configure the FW library through the STM8 MC Builder PC software
3. Develop your own applications in conjunction with a third-party IDE and C compiler

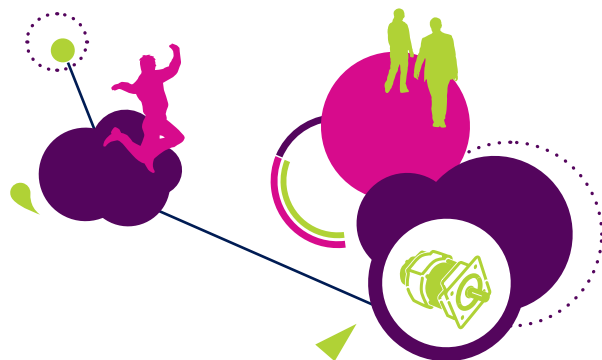



## STM32 32-BIT MICROCONTROLLERS

The STM32 family of 32-bit Flash microcontrollers based on the ARM Cortex-M processor is designed to offer new degrees of freedom to MCU users. By bringing a complete 32-bit product range that combines high-performance, real-time, low-power and low-voltage operation, while maintaining full integration and ease of development, the STM32 family helps you create new applications and design in the innovations you have long been dreaming about.

### KEY FEATURES

- Advanced timer for 3-phase inverters and full-bridge converter drivers
- Fast 12-bit ADC (0.2µs) can be triggered by timer events
- ART Accelerator™, Control loop booster
- SIL ready, Class B, HW safety
- Integrated analog
- Connectivity (Ethernet, CAN, FW Com stack...)
- Temperature range up to 105 °C, 125 °C
- Precise internal oscillator

#### STM32F3, F1, F0 Mainstream



- Rich advanced analog (F3)
- Control loop optimized
- Advanced PWM Motor Control timer

From cost optimized to full featured SoC solution for Motor Control

#### STM32F7, F4, F2 High-performance



- Up to 216 MHz CPU frequency
- Advanced Connectivity
- Graphic Accelerator

Motor Control and much more...

#### STM32L4, L1, L0 Ultra-low-power



- EEPROM
- LCD interface
- Lowest power mode + RAM + RTC = 0.8 µA

Low power performance and features

# STM32 MICROCONTROLLERS: ECOSYSTEM

## Hardware tools



STM32 Nucleo board



Flexibility prototype

Discovery kit



Creative demos

Evaluation board



Full-feature evaluation

## Software tools



STM32CubeMX

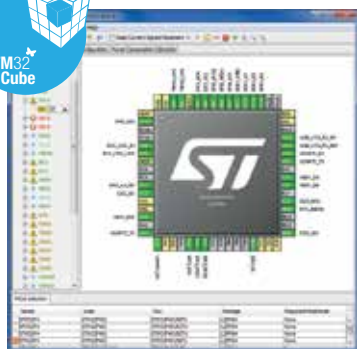

Configure and generate code

Partners IDEs



Note: Free full version of Keil MDK-ARM on all STM32F0 and STM32L0

Compile and debug

STMStudio

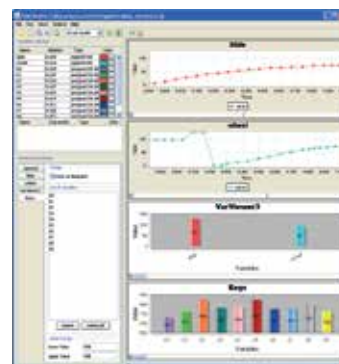

Monitor

## Embedded software

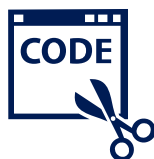

STM32Snippets  
[www.st.com/stm32snippets](http://www.st.com/stm32snippets)

High optimization  
low portability



STM32Cube  
and Std Libraries  
[www.st.com/stm32cube](http://www.st.com/stm32cube)

Average optimization  
STM32 portability



CMSIS and  
Mbed SDK  
[www.mbed.org](http://www.mbed.org)

Low optimization  
ARM portability



Virtual machines  
and models  
[www.st.com/stm32-java](http://www.st.com/stm32-java)

Low optimization  
large portability

# STM32 MICROCONTROLLERS: MOTOR CONTROL ECOSYSTEM

## The STM32 PMSM FOC SDK

(Software Development Kit) -STSW-STM32100- lets users evaluate STM32 performance and develop a complete application for single or multi 3 phase permanent-magnet motor drive systems (sensored or sensorless). It includes:

### 1. PMSM FOC firmware library including the following features (among others):

- **Sensorless** motor control algorithm (ST patent) based on the High Frequency Injection (HFI) method. The HFI algorithm allows precise rotor angle detection in field-oriented control (FOC). It enables very low or zero speed operation for compressor applications (Air Con, Fridge) with reliable and efficient motor start-up, and for washing machines where it increases the efficiency of each washing cycle (low speed, full torque)
- **“Maximum torque per ampere”** (MTPA) that optimizes the motor torque for each load and increases efficiency
- **“Feed-forward”** that improves current control at high speeds

The new Motor Control firmware library focus on Motor Control accessibility with “Plug and Spin” features like:

- **“Motor Profiler”**: Auto-measure Electromechanical Parameters of PMSM Motors
- **“One Touch Tuning”**: Single parameter to set-up the speed controller according the type of load

**2. ST MC Workbench** is the PC software graphical configurator of the PMSM FOC firmware library. Through this GUI, the user generates all the parameter header files needed to configure the library according to application needs and can in real-time monitor and change certain variables of the algorithm.

## STM Studio

A graphical real-time diagnostic tool

## A wide range of HW boards

From standalone control boards and power boards up to a complete Motor Control Kit, are available to evaluate ST solutions for Motor Control applications.

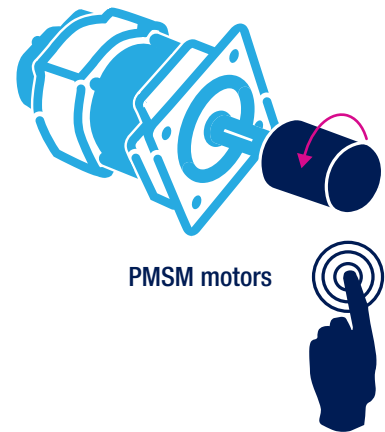
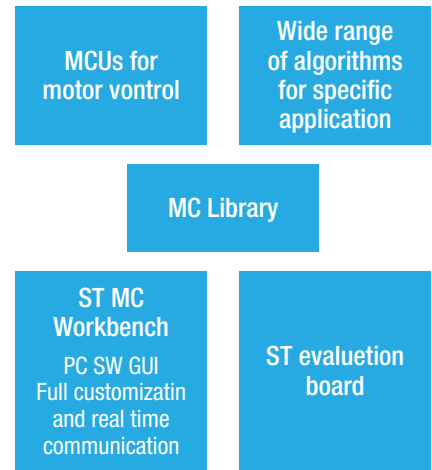

# MOTOR CONTROL FIRMWARE FEATURES

STM32F4xx, STM32F3xx						
STM32F103x HD/XL, STM32F2xx						
STM32F103x LD/MD						
STM32F100x, STM32F0xx						
1shunt	Flux Weakening	IPMSM MTPA	3shunt	Dual FOC	HFI <sup>1</sup>	
Feed Forward	Sensor-less (STO + PLL)	Sensor-less (STO + Cordic)	FreeRTOS F103, F2xx	Max FOC <sup>3</sup> F103 ~23 kHz F2xx ~40 kHz	Max FOC <sup>3</sup> F3xx ~30 kHz F4xx ~50 kHz	
Encoder	Hall sensors	Startup on-the-fly	ICS <sup>2</sup>	Max Dual FOC <sup>3</sup> F103 ~20 kHz F2xx ~36 kHz	Max Dual FOC <sup>3</sup> F3xx ~27 kHz F4xx ~45 kHz	
ST MC Workbench support	USART based com protocol add-on	Max FOC F100 ~11 kHz F0xx ~12 kHz	Max FOC <sup>3</sup> ~23 kHz			

Note: 1. High Frequency Injection  
 2. STM32F103, F2, F4  
 3. Max FOC estimated in sensorless mode

## STM32F evaluation boards for motor control

ST proposes a wide range of evaluation boards for comprehensive evaluation of ST's products and solutions while reducing your development time. In particular, all of ST's microcontroller evaluation boards have ST's standard MC connector on-board allowing the use of the board in conjunction with any of the power stage evaluation boards listed in the 3-phase brushless motor paragraph.

Order code	Description	Supported by STM32 PMSM FOC SDK	Documentation
STM32072B-EVAL	Evaluation board with STM32F072VB MCU	Yes	UM1714
STM32100E-EVAL	Evaluation board with STM32F100ZE MCU	Yes	UM1055
STM3210E-EVAL	Evaluation board with STM32F103Zx MCU	Yes <sup>1</sup>	UM0488
STM3221G-EVAL, STM3220G-EVAL	Evaluation board with STM32F217IG MCU, Evaluation board with STM32F207IG MCU	Yes	UM1065, UM1057
STM32303E-EVAL	Evaluation board with STM32F303VE MCU	Yes	UM1807
STM3240G-EVAL, STM3241G-EVAL	Evaluation board with STM32F407IG MCU, Evaluation board with STM32F417IG MCU	Yes	UM1461, UM1640
STEVAL-IHM022V1	Dual PMSM evaluation board based on STM32F103ZE MCU	Yes	UM0683, UM0688
STEVAL-IHM033V1	Control stage based on the STM32F100CB microcontroller for motor control with serial communication user interface	Yes	UM1077
STEVAL-IHM036V1	Low power motor control board featuring the SLLIMM™ STGIPN3H60 IPM and STM32F100 MCU	Yes	UM1483
STEVAL-IHM042V1	PMSM FOC motor driver based on L6230 motor driver and STM32F303 MCU	Yes	DB1810
STEVAL-IFN003V1	PMSM FOC motor driver based on L6230 motor driver and STM32F103 MCU	Yes (SDK v3.0 + plug-in)	UM1478

Note: 1. STM3210E-EVAL, due to some resource sharing, overcurrent protection and LCD, cannot be used at the same time.

### READY TO USE MOTOR CONTROL EVALUATION KITS:

- STM3210B-MCKIT: Full features kits for 3-phase motor control application development
- STM32 Nucleo Pack for motor control (P-NUCLEO-IHM001): Complete evaluation kit -FOC, 6-step FW example based- for evaluation, fast prototyping, makers and education



P-NUCLEO-IHM001



# Gate drivers solution for IGBTs and MOSFETs

ST's power MOSFET and IGBT gate drivers include integrated half-bridge, single and multiple low-side gate drivers and galvanically isolated device. ST's MOSFET/IGBT drivers provide state-of-the-art integration, reducing BOM cost and final application dimensions, while also increasing robustness and noise immunity.

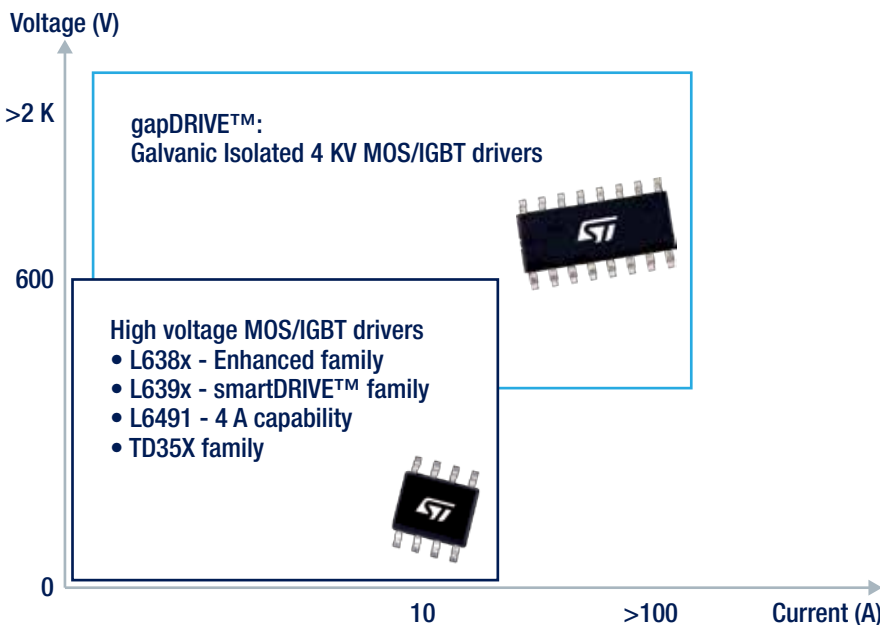
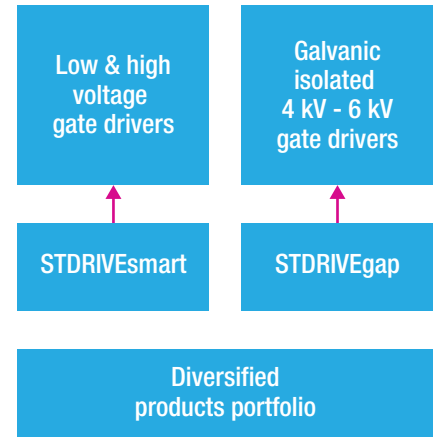
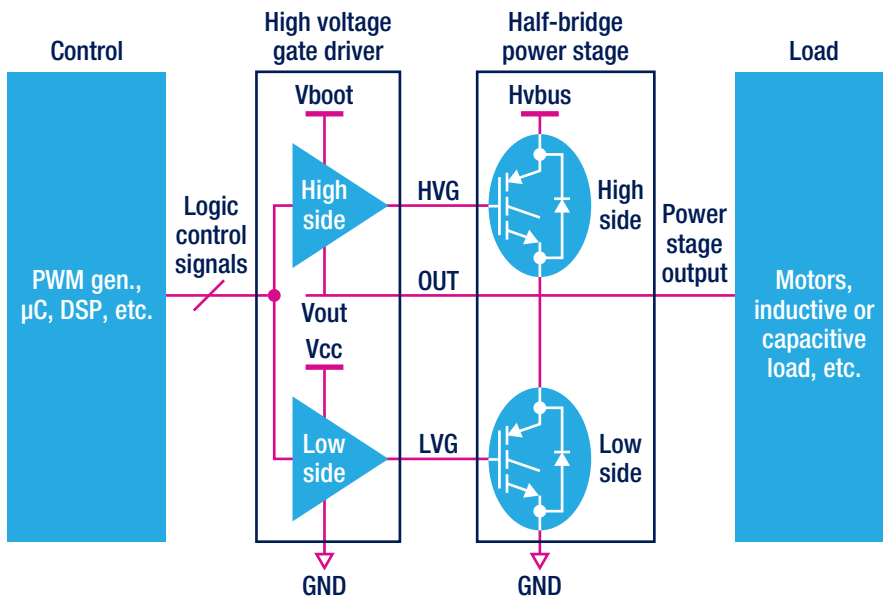

## KEY FEATURES

- Half-bridge, single-channel and multichannel gate drivers
- State-of-the-art integration thanks to:
  - HV bootstrap diode
  - Op amp
  - Comparator
  - Smart shutdown
  - Undervoltage lock out (UVLO)
  - Programmable deadtime

## gapDRIVE™

The new STGAP1S is an innovative IGBT/ Mosfet driver 4 KV galvanically isolated which provides robustness and noise immunity, a thick oxide isolation layer is grown on-chip to build a miniature transformer which is used to inductively transfer signals between input and output, best in class protection features are embedded and high configurability level reached through SPI interface.

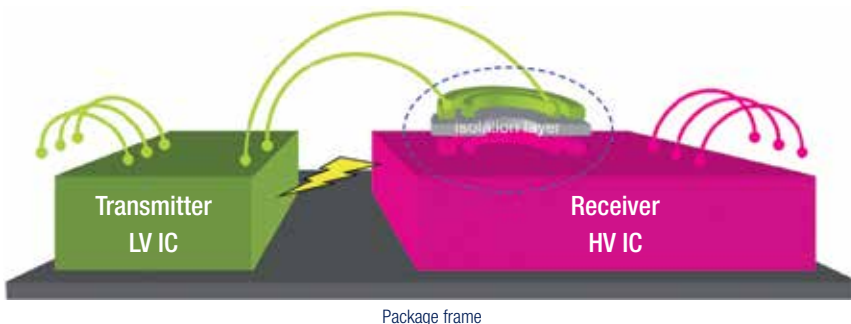

General description	Supply voltage (VDD) min (V) max (V)	Input configuration	Output current-Max nom (A)	Undervoltage lockout (V) (VH ON) & (VH OFF) nom (V)	Supply voltage (VH) min, max (V)	Negative gate drive ability	Miller Clamp, DESAT detection, SENSE comparator	Pin Count nom ()
<b>STGAP1S</b>	3 V, 5.5 V	SD, IN+, IN-	5	programmable	4.5 , 36 V	yes	yes	24

## High voltage MOS/IGBT drivers

L638xE and the smartDRIVE™ L639x are the two high-voltage half-bridge gate driver families that are leading the industrial market from home appliances to HVAC systems, from pumps and fans to factory automation. The brand new L6491 half bridge driver integrating Smart Shutdown feature and capable of up to 4A and 600V operating voltage supply. TD35x family complete the ST gate driver offer and feature single-channel drivers. In particular, the TD350E is an innovative gate driver where control and protection functions are included and allow the design of highly reliable systems. The innovative active Miller clamp function eliminates the need for negative gate drive in most applications and allows the use of a simple bootstrap supply for the high-side driver. ST's power MOSFET and IGBT gate drivers include integrated half-bridge, single and multiple low-side gate drivers and galvanically isolated device

Part number	Logic interface		V <sub>CC</sub> max (V)	UVLO on V <sub>CC</sub> (V)	UVLO on V <sub>BOOT</sub> (V)	Interlocking - DT (μs)	Op Amp	Comparator	# Pins
	Input configuration	input configuration							
<b>Half-bridge drivers</b>									
<b>L6384E</b>	Single in, SD	5, 15 V	18	10 / 12	-	0.5 to 2.7	No	No	8
<b>L6385E</b>	HIN and LIN	5, 15 V	18	8.3/9.6	8.2/9.5	-	No	No	8
<b>L6386E</b> <b>L6386AD</b>	HIN, LIN, SD	5, 15 V	18	10 / 12 8.3 / 9.6	9.9/11.9 8.2/9.5	-	No	Yes, uncommitted	14
<b>L6387E</b>	HIN and LIN	5, 15 V	18	5.5/6	-	Interlocking	No	No	8
<b>L6388E</b>	HIN and LIN	3.3, 5, 15 V	18	8.3 / 9.6	8.2/9.5	0.32	No	No	8
<b>L6390</b>	HIN, LIN, SD	3.3, 5, 15 V	21	10.5/12	10/11.5	0.18 to 3	Yes	Yes, committed to fault + SSD	16
<b>L6391</b>	HIN, LIN, SD	3.3, 5, 15 V	21	10.5/12	10/11.5	0.18 to 3	No	Committed to fault + SSD	14
<b>L6392</b>	HIN, LIN, SD	3.3, 5, 15 V	21	10.5/12	10/11.5	0.18 ÷ 3	Yes	No	14
<b>L6393</b>	Phase, brake, SD	3.3, 5, 15 V	21	8.0/9.5	8/9	0.18 ÷ 3	No	Yes, uncommitted	14
<b>L6395</b>	Single input with SD and Brake	3.3, 5, 15 V	20	8.8/9.5	8/8.6	-	No	No	8
<b>L6398</b>	HIN and LIN	3.3, 5, 15 V	21	8.0/9.5	8/9	0.32	No	No	8
<b>L6491</b>	HIN and LIN	3.3, 5, 15 V	21	8.7/9.3	8/8.6	0.2 to 2.6	No	Yes, committed to fault + SSD	14
<b>Single-channel drivers</b>									
<b>TD350</b>	Single in (opto/pulse trans compatible)	5 V	26	11	-	-	No	-	14
<b>TD351</b>	Single in (opto/pulse trans compatible)	5 V	26	11	-	-	No	No	8
<b>TD352</b>	Single in (opto/pulse trans compatible)	5 V	26	11	-	-	No	No	8



# Signal conditioning

## Operational amplifier

ST has a wide range of op amps, including both industry-standard and high-performance op amps. Our strengths include:

- Growing 16 V CMOS portfolio including precision and wide bandwidth op amps
- Reliable high-volume supplier of both standard and high-performance op amps
- Space-saving packages, such as DFN, QFN, SOT-23 and SC-70

Our JFET, bipolar, CMOS and BiCMOS technologies allow our products to support:

- A wide supply range, from 1.5 V to 36 V
- High ratios of performance-to-power consumption

Our automotive-grade products are AEC-Q100 qualified and tested with certified high-reliability flow, to meet the very specific, rigorous demands of the automotive market.

### ST OP-AMPS PORTFOLIO: BY VOLTAGE AND TECHNOLOGY

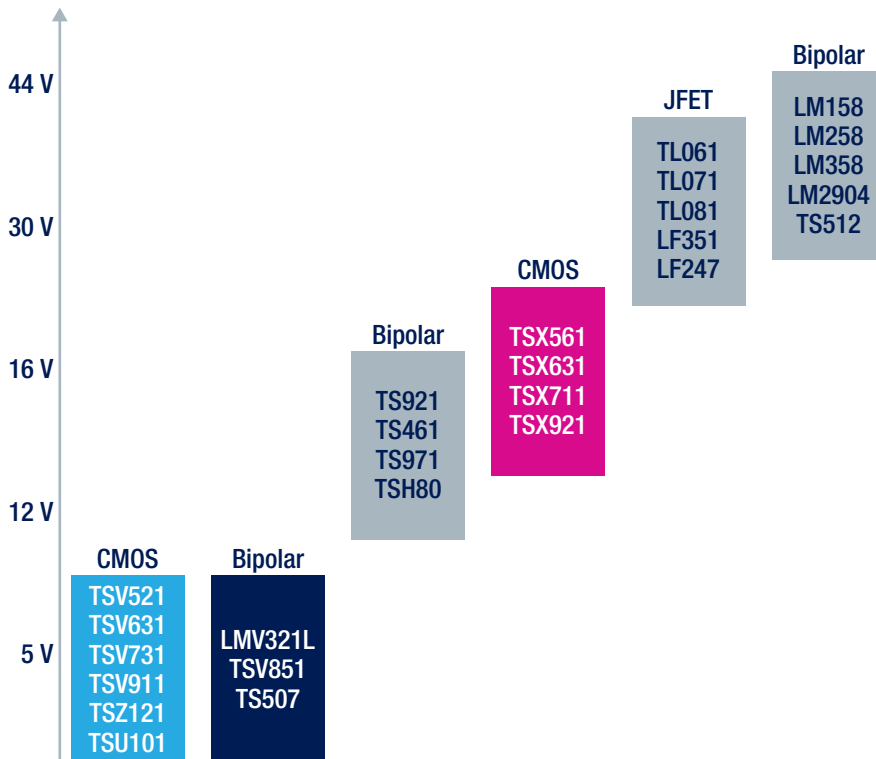

#### HIGHLIGHT: TSZ12

The TSZ12 series of high precision operational amplifiers offers very low input offset voltages with virtually zero drift. Design engineers can use the devices to achieve high accuracy in signal-processing functions without the need for calibration. In addition, the accuracy of the amplifiers' output is almost unaffected by variations in temperature.

Applications	Features	Products
Low side current sensing	Precision, low $V_{io}$ as good as $5\ \mu\text{V}$	TSZ121, TSV731, TSX711
Temperature sensing	Low power consumption as good as $580\ \text{nA}$	TSU101, TS941, TSV631
Vibration sensing	High Bandwidth up to $20\ \text{Mhz}$	TSX9291, TSH22, TSV991
Angle measurement DC brushless motor	High output Current, $> 100\ \text{mA}$	TSX561, TS982, TS507
High side current sensing	High Common-mode Voltage up to $70\ \text{V}$	TSC101, TSC102, TSC103

### High-side current sensing (TSC series)

Accurate sensing of currents is central to enhancing application safety. Controlling the current within set boundaries avoids overheating and short circuits. Current measurement is also an essential part of energy metering.

The main features of our growing high-side current-sense amplifier portfolio are:

- Up to  $70\ \text{V}$  line monitoring
- Integrated solutions (for example, inclusion of EMI filtering on output) for faster design times and a reduced BOM
- Robust devices that do not require external protection
- Automotive-grade qualified current-sense amplifiers

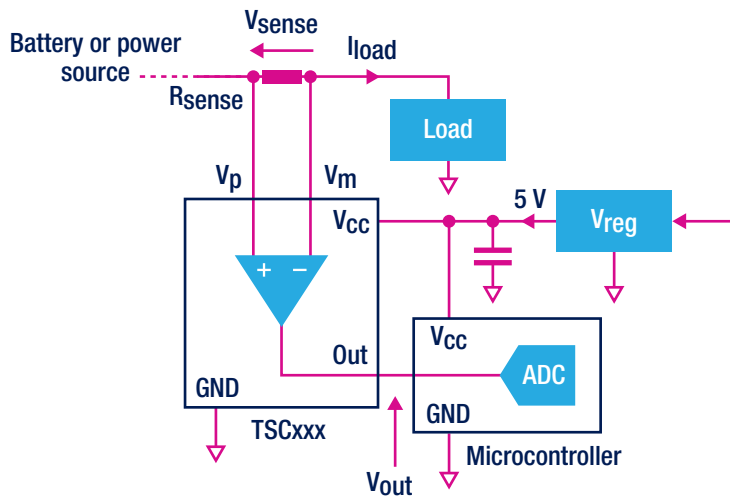

#### HIGHLIGHT: TSC103

- Common-mode voltage:  $2.9$  to  $70\ \text{V}$
- Optional dual-supply configuration to reach  $-2.1\ \text{V}$  to  $65\ \text{V}$  common-mode range
- Rugged input pin sustain  $-16$  to  $+75\ \text{V}$  and  $2.5\ \text{kV}$  ESD
- Pin-selectable gain:  $20\ \text{V/V}$ ,  $25\ \text{V/V}$ ,  $50\ \text{V/V}$ ,  $100\ \text{V/V}$
- Low current consumption:  $360\ \mu\text{A}$

Order code	Description	Documentation
STEVAL-ISQ013V1	High-side current-sense amplifier demonstration board based on TSC101	AN3222
STEVAL-ISQ007V1	Low-side current sensing based on TS507	AN2727
STEVAL-ISQ014V1	Low side current sensing based on TSZ121	UM1737



## Comparators

ST is a leading supplier of comparators, and our portfolio offers:

- High-speed comparators, with response times as fast as 8 ns
- Micropower comparators with operating currents as low as 210 nA
- High-temperature (150 °C) qualified devices
- Guaranteed specified min/max electrical performances

Our automotive-grade products are AEC-Q100 qualified and tested with certified high-reliability flow, to meet the very specific, rigorous demands of the automotive market.

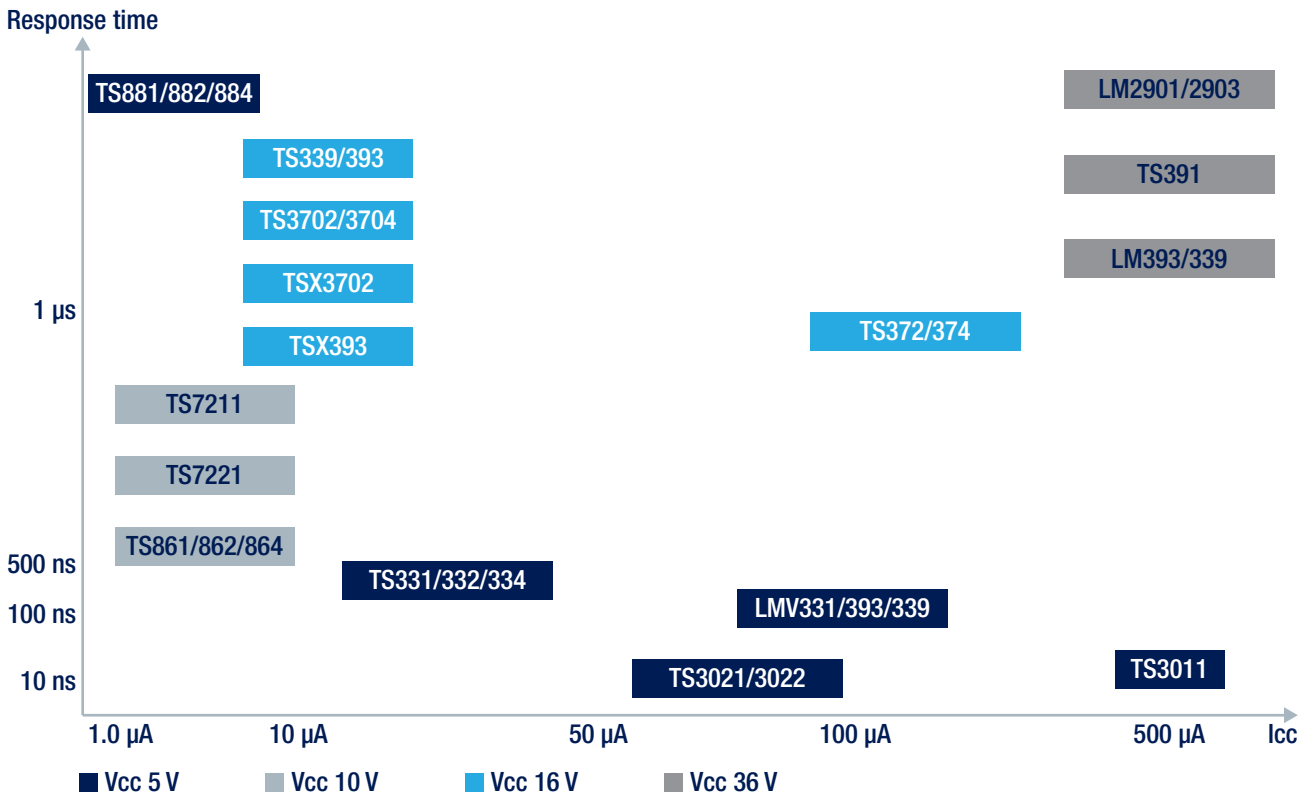





# life.augmented



© STMicroelectronics - October 2015- Printed in United Kingdom - All rights reserved  
The STMicroelectronics corporate logo is a registered trademark of the STMicroelectronics group of companies  
All other names are the property of their respective owners

