

Project Number: RD4-ABCK

# **Motorcycle Rear Suspension**

A MAJOR QUALIFYING PROJECT REPORT SUBMITTED TO THE FACULTY OF

**WORCESTER POLYTECHNIC INSTITUTE**

IN PARTIAL FULFILMENT OF THE REQUIREMENTS FOR THE DEGREE OF

BACHELOR OF SCIENCE BY

*JACOB BRYANT*

*ALLYSA GRANT*

*ZACHARY WALSH*

DATE SUBMITTED: 26 April 2018

REPORT SUBMITTED TO:

*Professor Robert Daniello  
Worcester Polytechnic Institute*

## Abstract

Motorcycle suspension is critical to ensuring both safety and comfort while riding. In recent years, older Honda CB motorcycles have become increasingly popular. While the demand has increased, the outdated suspension technology has remained the same. In order to give these classic motorcycles the safety and comfort of modern bikes, we designed, analyzed and built a modular suspension system. This system replaces the old twin-shock rear suspension with a mono-shock design that utilizes an off-the-shelf shock absorber from a modern sport bike. By using this modern shock technology combined with a mechanical linkage design, we were able to create a system that greatly improved the progressiveness and travel of the rear suspension.

## Acknowledgements

The success of our project has been the result of many individuals over the course of the past eight months, and it is our privilege to recognize and thank these individuals for their unwavering help and support throughout this process.

First and foremost, we would like to thank our Worcester Polytechnic Institute advisor, Professor Robert Daniello for his guidance throughout this project. His comments and constructive criticism regarding our design and manufacturing strategies were crucial for us in realizing our product.

We would also like to thank two other groups at WPI: The Mechanical Engineering department at WPI and the Lab Staff in Washburn Shops. The Mechanical Engineering Department was instrumental in their help in the administrative portions of the project, including providing our budget and ordering and delivering multiple orders of material for us during this project. Additionally, the Lab Staff in Washburn Shops cannot be thanked enough for their assistance and guidance in the manufacturing our final product.

## Table of Contents

Abstract.....	2
Acknowledgements.....	3
Table of Contents.....	4
Table of Figures .....	6
Table of Tables .....	9
Introduction.....	10
2. Background.....	12
2.1 Physics & Fundamentals.....	12
2.2 Geometry.....	17
2.3 Evolution of rear suspension design .....	20
2.3.1 Early Designs .....	20
2.3.2 Swing Arm systems .....	22
2.4 Current Designs .....	29
2.5 Specifics on CB Suspensions.....	35
2.7 Market.....	36
2.8 Current Solutions .....	38
3. Methodology.....	40
3.1 Determine Suspension System Requirements and Specifications .....	40
3.2 Create Preliminary Designs .....	40
3.3 Evaluate Preliminary Designs.....	41
3.5 Final Design Selection .....	42
3.6 Initial Prototype Iteration of Designs.....	43

3.7 Prototype Design.....	43
4. Analysis and Findings.....	44
4.1 Determine the Suspension System Requirements.....	44
4.2 Create Preliminary Designs .....	45
4.3 Evaluate Preliminary Designs .....	51
4.4 3D Modeling.....	60
4.5 Final Design Selection and Initial Analysis .....	62
4.6 Initial Prototype and Iteration and Final Analysis .....	65
4.7 Prototype Design.....	68
5. Conclusions.....	78
5.1 Project Specifications.....	78
5.2 Future Recommendations .....	78
6. References.....	81

## Table of Figures

Figure 1 Two Section Variable Rate Spring (Automotive Thinker).....	13
Figure 2 True Variable Rate Spring (Automotive Thinker) .....	13
Figure 3 Linear to Variable Rate Spring (Automotive Thinker) .....	13
Figure 4 Anti-Squat Forces (All About Geometry) .....	15
Figure 5 Anti-Squat Geometry (Avoid squat at recumbent).....	16
Figure 6 Center of Gravity Geometry (Foale, 4-28).....	17
Figure 7 Trail and Rake (Foale, 3-1) .....	18
Figure 8 Frame Design of a Rear Suspension System for Two-Wheeled Vehicle (Parigian) .....	19
Figure 9 1913 Pope motorcycle with plunger system setup on the rear axle (Red) .....	20
Figure 10 1951 BMW, note the plunger system at the rear axle (Dean) .....	21
Figure 11 Diagram of rear plunger system (Foale, 1-21) .....	22
Figure 12 Standard Swing-arm design (Manufacturing) .....	23
Figure 13 1928 Vincent HRD (Classic British Motorcycles).....	23
Figure 14 Velocette's taper design swing-arm (Foale, 1-22) .....	24
Figure 15 Norton Featherbed (Motorcycle Classics).....	25
Figure 16 BSA 250cc grand prix racer (Foale, 1-24) .....	25
Figure 17 Rear fork triangulated below pivot on the Suzuki RG500 GP racer (Foale, 1-25) .....	26
Figure 18 Kawasaki KR500 swing-arm design (Foale, 1-25) .....	27
Figure 19 Unique suspension design on Yamaha OW61 GP racer (Foale, 1-25) .....	28
Figure 20 Parker Motorcycle Suspension System Design. (Parker).....	29
Figure 21 Dual-Spring Motorcycle Suspension System Design. (Cullinan) .....	30
Figure 22 Dual-Springs in a Motorcycle Suspension System. (Cullinan) .....	31

Figure 23 Design of a System with Rear Wheel Suspension Springs 1 (Macdonald).....	32
Figure 24 Design of a System with Rear Wheel Suspension Springs 2 (Macdonald).....	32
Figure 25 Design of a Motorcycle Suspension System with Trailing Links (Jarman).....	33
Figure 26 Kinetic Motorcycle suspension kit installed on frame with two shocks .....	38
Figure 27 CB750 with Kinetic Motorcycle suspension kit.....	38
Figure 28 2D Drawing for Preliminary Design 1 .....	45
Figure 29 2D Drawing for Preliminary Design 2 .....	46
Figure 30 2D Drawing for Preliminary Design 3 .....	47
Figure 31 2D Drawing for Preliminary Design 4 .....	48
Figure 32 2D Drawing for Preliminary Design 5 .....	49
Figure 33 2D Drawing for Preliminary Design 6 .....	50
Figure 34 Geometric Considerations for Progressiveness (Foale, 8-8) .....	51
Figure 35 Benchmark - Wheel Rate for 2008-2016 Yamaha R6 (SuspAct, 2018) .....	52
Figure 36 Wheel Rate for Design 1 .....	53
Figure 37 Wheel Rate for Design 2 .....	54
Figure 38 Wheel Rate for Design 3 .....	55
Figure 39 Wheel Rate for Design 4 .....	56
Figure 40 Wheel Rate for Design 5 .....	57
Figure 41 Wheel Rate for Design 6 .....	58
Figure 42 3D Model of Design 4 .....	60
Figure 43 3D Model of Design 5 .....	61
Figure 44 3D Model of Design 1 .....	61
Figure 45 Safety Factor for Von Mises Stresses.....	63

Figure 46 Deformation Analysis.....	64
Figure 47 Updated SolidWorks Assembly .....	65
Figure 48 FBD for Bolt.....	66
Figure 49 Image of .625 insert after facing, contouring, drilling, and cutoff operations .....	69
Figure 50 Image of .375 insert after facing, contouring, drilling, and cutoff operations .....	69
Figure 51 Image of link after facing, contouring, and pocketing operations on one side of part.	70
Figure 52 Image of link after facing and contouring operations on opposite side of part .....	71
Figure 53 Image of link after pocketing operation on part rotated 270 degrees from original position.....	72
Figure 54 Tie Rods with Ball Rod Ends .....	73
Figure 55 Side View of Rocker Link .....	73
Figure 56 Side Profile of Suspension System on Bike .....	75
Figure 57 Suspension Rocker Link on Pivot from Rear.....	75
Figure 58 Suspension System from Rear.....	76
Figure 59 Detail View of Shock, Link, and Pivot.....	77



## Table of Tables

Table 1 Motorcycle Registration and Sales in US (Morris) .....	36
Table 2 Motorcycle Owners by Age in United States (Halliday) .....	36
Table 3 Preliminary Decision Matrix .....	59
Table 4 Table of Safety Factors .....	67

## Introduction

In recent years, Honda CB motorcycles have been exploding in popularity with the motorcycle community. However, while the demand for these bikes has been increasing, the suspension technology on these old bikes has remained stagnant. There is a wide array of after-market products that address this problem for the front suspension, but few are available that address the rear suspension. While there are replacement shocks that improve the rear suspension, there is no product that changes the fundamentals of the rear suspension to bring it more in line with modern day systems. This increase in demand and lack of supply was the driving motivator behind our project.

The goal of this project was to create a modern modular rear suspension system that could be adapted to fit a variety of Honda CB motorcycles. This suspension system will replace the twin shock rear suspension that comes standard on these older bikes with a much more modern system. This will positively affect the characteristics of the motorcycle to increase wheel travel, comfort, and progressiveness. In order to accomplish this goal, we created and completed the following objectives. They are:

1. Determine suspension system requirements and specifications;
2. Create preliminary designs;
3. Evaluate designs and select the three best candidates;
4. Create 3D models of designs and analyze;
5. Select best design based on previous analysis;
6. Iteration of design;
7. Prototype most suitable design;
8. Physical analysis of suspension system;
9. Determine price of product for consumer.

In order to accomplish these objectives and ultimately our main goal, we started performing background research on the fundamentals of modern motorcycle suspensions. With this information, we were able to design several linkages and determine their progressiveness. After determining which models were the most progressive, we 3D modelled them in Dassault Systemes SolidWorks and subsequently, we were able to determine which design would be the most feasible. For our final design, we performed a comprehensive analysis on the system to make sure that it would withstand the forces that a typical motorcycle suspension experiences. Next, our

prototyping occurred in two stages. We started with a PVC and wood model to ensure that the suspension would fit in the necessary location without any interference issues. After this, we moved to our actual prototype made from our final material selection. Once it was attached to the bike, we tested the performance of the suspension against the values we anticipated. Ultimately, although modifications would be made in future iterations, this suspension provides our design with proof of concept and is a viable option in modernizing Honda CB suspension.

## 2. Background

### 2.1 Physics & Fundamentals

Motorcycle suspension systems utilize the laws of mechanical physics to dissipate forces acting on the wheels, in order to provide a smooth and stable ride. Each system's unique geometry and components allow them to function to specific user needs. While the function of suspension is quite clear, the best design to achieve this goal is hardly so apparent. Suspension systems are comprised of various components, including the spring or shock absorber, the damping agent and the swing arm linkage mechanism. There are many forces that a rear motorcycle suspension and its accompanying swing arm have to withstand in order to allow it to be effective throughout its lifespan. The physics and geometry of rear motorcycle suspensions will be discussed in more detail in this section.

The main component of the suspension system is the spring. Mechanical law tells us the forces and energy contained in compressed springs is defined by the following equation (BBC).

$$F_{Spring} = -k * x$$

Here,  $k$  is the spring constant for the given spring and  $x$  is the distance the spring is compressed. While understanding the forces accompanying a suspension system spring is important, it is also important to understand the energy associated with the spring. The kinetic energy (KE) contained within a compressed spring is shown in the equation below.

$$KE_{Spring} = \frac{1}{2}k * x^2$$

Although Hooke's law is an idealized version, many springs aren't linear in their force per distance compressed. Variable rate springs are often used in industry to produce specific effects. For example, variable rate springs are often used in suspension systems to produce soft effects at the beginning of the stroke but much firmer effects towards the end of the stroke. The following charts show different variable rate spring systems. The  $x$  axis represents the distance compressed, and the  $y$  axis shows the force contained upon this compression. The numbers themselves are arbitrary and exist only to demonstrate the relationship between axes (Linear vs Progressive Rate Springs – Automotive Thinker).

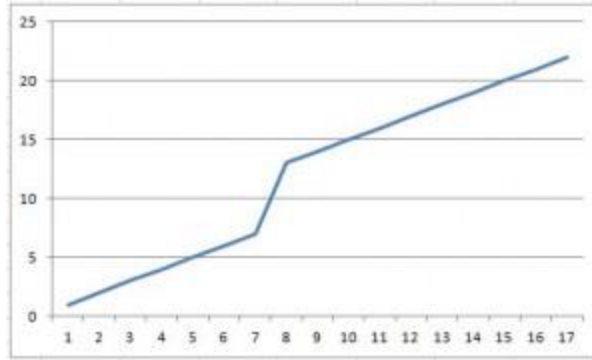

Figure 1 Two Section Variable Rate Spring (Automotive Thinker)

Figure 1 depicts one type of variable rate spring. This type of spring is split into two separate sections, each reacting linearly in its own rate. The stiffer portion of the spring does not compress until the soft side has compressed in full.

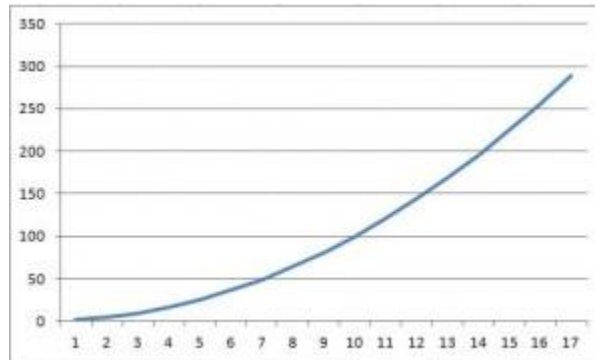

Figure 2 True Variable Rate Spring (Automotive Thinker)

Figure 2 depicts a truly progressive rate spring. The effective spring rate changes as the spring is compressed through the stroke.

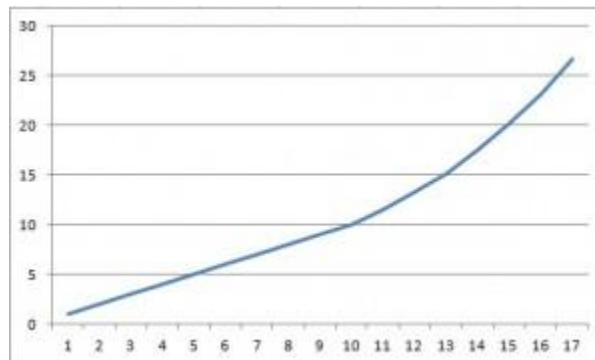

Figure 3 Linear to Variable Rate Spring (Automotive Thinker)

Lastly, Figure 3 depicts another type of a variable rate spring. The beginning of the stroke is linear but smoothly transitions into a progressive, more firm spring action.

The suspension system on a motorcycle is designed to return the wheels to neutral positions after being displaced by bumps, depressions or other opposing forces while in motion and dissipating energy associated with these to maintain comfort and control. The spring, as discussed earlier, compresses due to these forces, moving the wheel upwards, when the force acting on the wheel becomes less than the force of the spring, the wheel begins to move downward. The damping agent acts to prevent the spring from violently rebounding, and controls the rate at which the wheel returns to the normal position. Damping is an important function when considering suspension. Without damping, the wheel, and in reaction the bike, would continue to bounce on the spring until all of the energy dissipated entirely through friction, also known as hysteretic damping. Damping allows for more efficient and more rapid dissipation of energy in the spring. In compression damping, a fluid controls the rate of compression. During rebound damping this same fluid controls the rate at which the spring returns to neutral (Suspension Set-up 101).

When discussing motorcycle suspension springs, it is important to consider pre-load and sag. Pre-load is simply the amount the spring is compressed while the suspension system is fully extended. Spring sag, on the other hand, is the amount a spring displaces when going from zero loading to a certain applied static load. This static load is normally the weight of the rider and any gear they are carrying. Manufacturers prescribe a specified displacement range, or sag range, for each motorcycle. For example, many off-road motorcycles call for a sag range of 95-115mm. To set the sag properly, the bike would have to be placed on a stand so that the rear wheel is not touching the ground and measured accordingly. Because this load is different for every rider, and even differs depending on what additional gear the rider is using, the sag set up is essential for a proper handling motorcycle (Byrnes).

Understanding load transfers that occur on motorcycle suspension is important. During acceleration, several forces are present in the rear suspension, namely squat and anti-squat. Squat refers to the tendency for the rear suspension to compress upon acceleration due to rearward rotation from acceleration and aerodynamic forces. This load transfer is caused by four factors. These are: inertia from the force needed to accelerate the bike, aerodynamics and drag forces, hill descent (when applicable), and torque from the crankshaft and clutch (Foale 9-1). However, these forces are at least partially compensated for in swing arm and chain reactions.

There are two forces that work to extend the suspension to counter squat during acceleration.

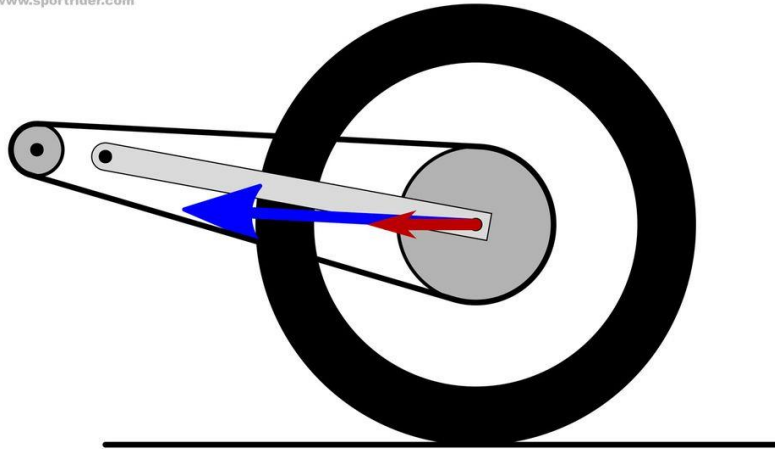
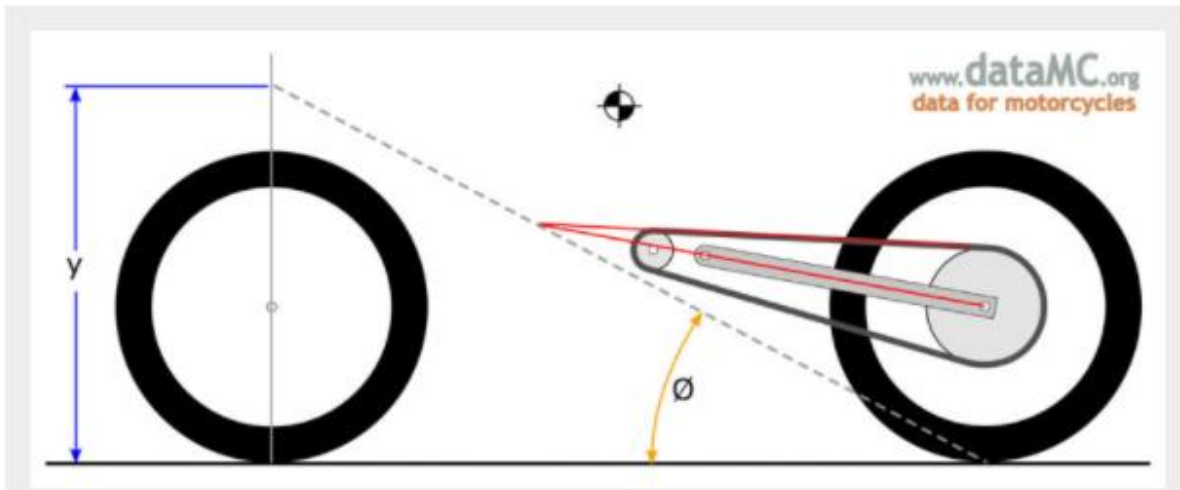

*Figure 4 Anti-Squat Forces (All About Geometry)*

Per Figure 4, one is driving force from the rear tire, which pushes the axle forward, while the other is the drive chain, which pulls the axle forward and down in the direction of the top chain run. Driving force acts horizontally on the axle and is directly proportional to the amount of acceleration. If the swing-arm slopes up from the axle toward the front of the machine and the pivot, driving force will extend the suspension. Chain pull force also acts on the axle, and its direction also changes as the suspension moves through its travel. The magnitude of the chain force is proportional to the driving force in relation to the rear sprocket size and rear tire diameter. Chain pull generally extends the suspension.

This anti-squat can be expressed in a variety of ways. One is to determine how much of the squat force the anti-squat forces offset, and express that as a percentage. To calculate anti-squat using this method, we can consider weight transfer, driving force and chain pull. This can be done by calculating torques about the swing-arm pivot. Because the actual mass of the motorcycle and the acceleration value are part of all three torques, these terms cancel out from the individual calculations (All About Geometry).

For the second two examples discussed on the next page, reference the following image in Figure 5 from dataMC.org (Avoid squat at recumbent).



*Figure 5 Anti-Squat Geometry (Avoid squat at recumbent)*

The second method of calculating anti-squat comes from Tony Foale and his book, Motorcycle Handling and Chassis Design: The Art and Science, which outlines a method of determining anti-squat percentage graphically. Consider the lines shown in Figure 5 – one through the swing arm and the axle and the other along the top chain run. These lines will intersect at some point. If a third line is drawn from the rear tire's contact patch and through this intersection point it will intersect the front tire's contact patch. The height of this intersection point can be expressed as a percentage of the height of the center of gravity and represents the quantity of anti-squat. This assumes that the center of gravity is mid-way between the axles, which is a reasonable assumption for most sport bikes. This method is simply a graphical representation of the statics calculation that the first method explains; however, these two methods only work if you can in fact accurately assume the COG is directly in between the axles.

A third way of calculating and expressing anti-squat is as an angular value. Here, the angle of the line from the rear tire's contact patch through the intersection of the lines drawn through the swing-arm and top chain run is used. A greater angle means more anti-squat, and a smaller angle means less anti-squat. This also removes the center of gravity position entirely from the expression.

The last main force that acts on the motorcycle, in particular the rear suspension system, occurs on the swing arm. These include lateral and torsional loading. The swing arm pivot is subject to high lateral loading. This twisting force from the drive chain in the area around this pivot applying stresses.



## 2.2 Geometry

One of the main geometrical considerations of the motorcycle design is the location of the center of gravity and wheel base. Generally, to avoid looping (front end raise during acceleration), the center of gravity cannot be too high. The latitudinal position of the center of gravity should not be higher than a 45 degree angle from the ground at the contact point of the rear tire. This drawing can be seen below in Figure 6 (Foale, 4-28). This relates to the suspension, because firmer preloads under light loading can raise the center of gravity putting the bike at risk of looping.

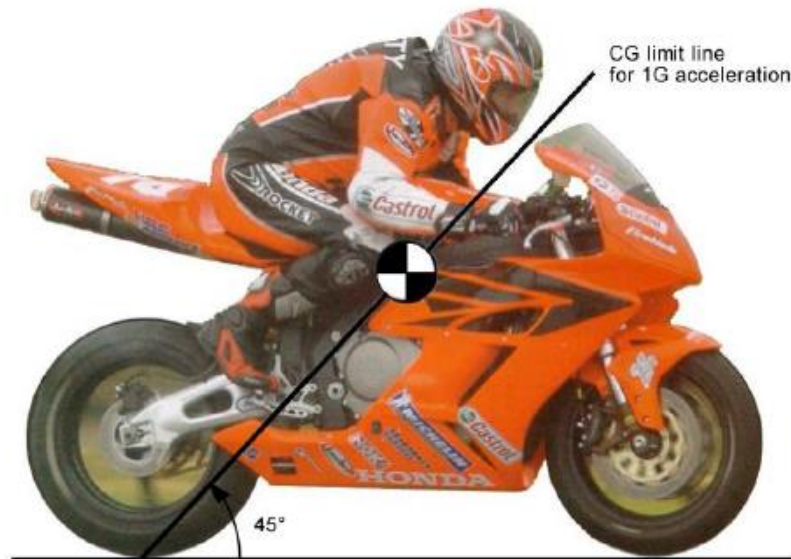

*Figure 6 Center of Gravity Geometry (Foale, 4-28)*

Another basic aspect of motorcycle geometry is the combination of rake angle, steering axis, and ground trail.

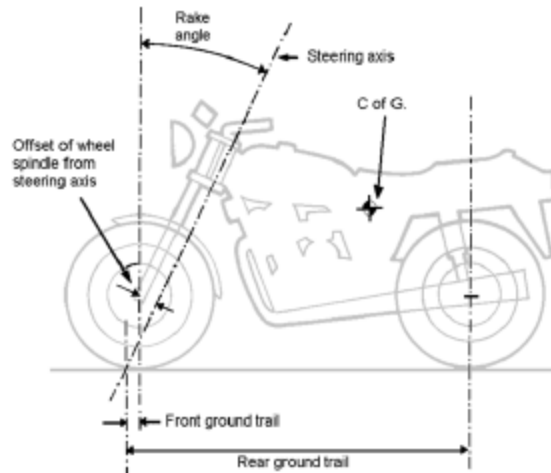

*Figure 7 Trail and Rake (Foale, 3-1)*

As seen above in Figure 7 above, the steering axis is the concentric line drawn through the steering head (Foale, 3-1). Front ground trail is the distance between the front wheel's contact point and the steering axis. The angle between the steering axis and a vertical line drawn through the front axle is the rake. These aspects of motorcycle geometry are not inherently related to rear motorcycle suspension, but the motorcycle is a complicated interconnected machine so the complete geometrical consideration is important.

A rear wheel suspension system for a two-wheeled vehicle generally utilizes a triangular frame with support axle plates that have aligned apertures (Parigian). In addition to this, most rear wheel suspension systems for two-wheeled vehicles often implement both an upper and lower arm assembly connecting the vehicle frame and the first and second support axle plates. In most suspension systems, a shock unit pivotally connects the lower arm assembly at one end to the vehicle frame at the opposite end (Parigian).

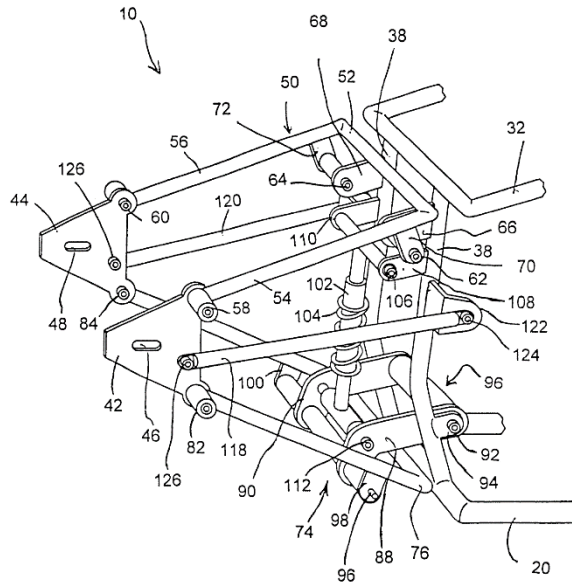

*Figure 8 Frame Design of a Rear Suspension System for Two-Wheeled Vehicle (Parigian)*

The diagram in Figure 8 demonstrates the common rear wheel suspension design for two-wheeled vehicles.

## 2.3 Evolution of rear suspension design

Motorcycle rear suspension has evolved greatly since the first commercial motorbike was produced in 1894. Originally, there was no real suspension system, just a wheel mounted to a rigid frame via an axle, much like a standard bicycle. Springs were added to seats to improve comfort, but offered no handling improvements. Eventually springs, shock absorbers, swing-arms and dampening systems were added to the rear suspension design. Because of these improvements in technology, modern motorcycles are far better handling and comfortable machines than their predecessors.

### 2.3.1 Early Designs

One prevalent early rear suspension design was the plunger system. This design used plunger springing to control the vertical movement of the rear axle. The first example of this design was used on the 1913 Pope (Wilson, 310). This design gained popularity for several reasons. Firstly, the success of BMW and Norton race bikes which utilized this design implied that it created better handling bikes than machines with ridged rear ends. Secondly was the ease that manufactures could fit these systems to the motorcycle frames they were already producing. Use of this design lasted into the 1950s, being incorporated by some notable manufacturers including Adler, Ariel, BMW, BSA, Indian, MZ, Sarolea, and Norton. Examples of a 1913 Pope and a 1951 BMW, both with plunger rear suspension, can be seen in Figure 9 and Figure 10 below.

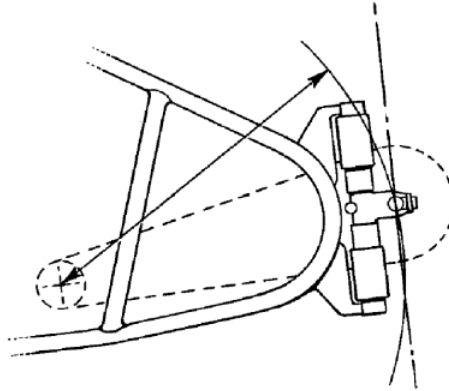

*Figure 9 1913 Pope motorcycle with plunger system setup on the rear axle (Red)*



*Figure 10 1951 BMW, note the plunger system at the rear axle (Dean)*

However, while this design became popular with manufacturers, it was plagued with several fundamental flaws (Foale, 1-21). Firstly, the addition of the plunger springs to the rear end allowed each side to flex independently in a vertical plane, destroying the triangulation of the seatstays and chainstays. Secondly, resistance to wheel tilting was also drastically reduced by this same independent movement. If forces acted on the wheel in such a way as to compress one spring more than the other, the wheel would tilt to one side, reducing stability. Thirdly, the straight-line vertical movement of the wheel considerably tightened the drive chain, which in turn limited the amount of wheel travel the system could allow. Figure 11 shows how the geometry of the rear suspension led to this occurrence.



*Figure 11 Diagram of rear plunger system (Foale, 1-21)*

This rear plunger system shows how its straight-line vertical movement tightens the chain at both ends of the travel, thus limiting total movement and requiring a slack chain at static load.

### 2.3.2 Swing Arm systems

The swing-arm, or pivoted fork, rear springing took much longer to become standard in the motorcycle industry despite it being a superior system. This was due to the fact that, unlike the plunger system, most rigid frames were not suitable for adaptation to this type of suspension (Foale, 1-22). This meant considerable more time and resources were required to create a proper frame and swing-arm system. However, this design eventually triumphed over the flawed plunger system and was common place on most motorcycles by the mid-1950s.

The primary design of a swing-arm rear sprung system is a parallelogram that connects to the frame at one end and the rear axle at the other (MMI, 282). Somewhere on this parallelogram are points for either suspension links (rigid members) or struts (shock absorbers, springs, etc.) to connect. The other end of this suspension geometry would normally then connect to the frame, creating a path for forces on the rear axle to be dissipated and then translated to the rigid frame. A diagram of a standard swing-arm can be seen in Figure 12 below. This features an aluminum construction and strut mounting tabs on each side of the unit directly above the rear axle.

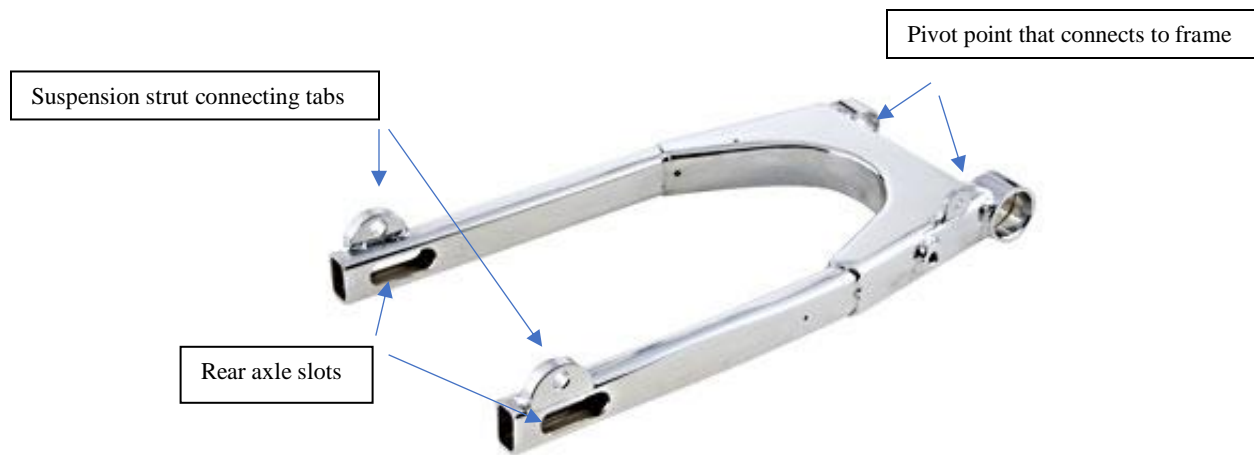

*Figure 12 Standard Swing-arm design (Manufacturing)*

Some manufacturers did not take so long to recognize the advantages of a sprung rear swing-arm, and certain designs even pre-date the plunger systems. The Vincent motorcycle company designed a triangulated pivot-fork layout that they standardized on their HRD model, which was produced from 1928-1955 (Foale, 1-22). With this design, they were able to obtain great strength and rigidity by triangulating the arms of the fork, and mounting it on a very wide pivot, utilizing pre-loaded taper-roller bearing to negate slack movement. The HRD model and this Vincent's early swing-arm design can be seen in Figure 13 below.



**CLASSIC-BRITISH-MOTORCYCLES.COM**

*Figure 13 1928 Vincent HRD (Classic British Motorcycles)*

This method of triangulating rear swing-arms was very popular in early designs. Moto Guzzi, an Italian motorcycle manufacturer, chose this method when they introduced rear swing-arm springing to their bikes in 1935 (Foale, 1-22). Triangulation added strength and torsional rigidity to the swing-arm, but required the use of more material and did not offer additions to lateral stiffness. For these reasons, Moto Guzzi decided to remove the triangulation, and instead construct their swing-arms from very large diameter welded tubing, which they claimed to be as stiff torsionally, and stiffer laterally. The next iteration of this design was developed by Velocette, where they constructed the arms out of taper diameter and taper-gauge tubes. This was first used in production on Velocette's Mark VIII KTT in 1939. This specific swing-arm is detailed in Figure 14 below.

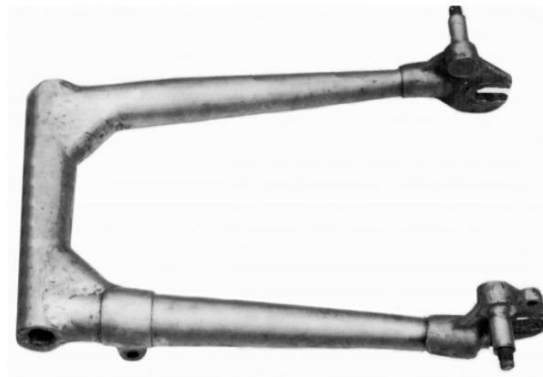

*Figure 14 Velocette's taper design swing-arm (Foale, 1-22)*

However, many plain swing-arms lacked adequate torsional stiffness without triangulation, which gave rise to the popular method of using matched suspension struts for the left and right arms (Foale, 1-23). This matching of struts allowed forces on each side of the swing-arm to be dissipated evenly, reducing the occurrence of twisting forces acting on the arms. One of the most renowned frames to incorporate a plain swing-arm was the Norton Featherbed, which had exceptional frame and swing-arm stiffness compared to its competitors at its release in 1950. Norton's acclaimed motorcycle can be seen in Figure 15 below showing its plain swing-arm and dual rear strut design.



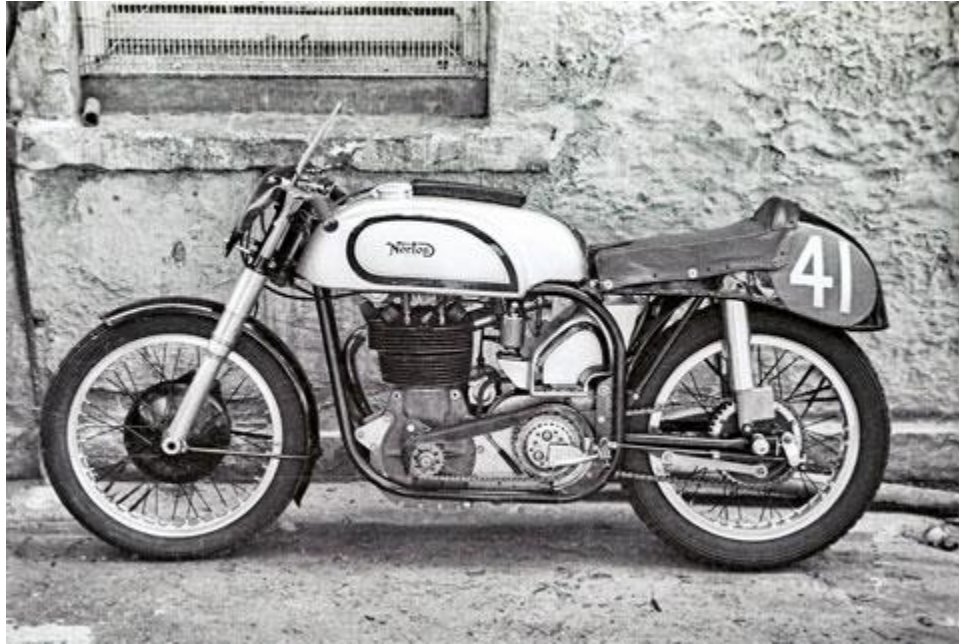

*Figure 15 Norton Featherbed (Motorcycle Classics)*

Because there are many different fields of thought on what makes a superior swing-arm design, many permutations of rear fork types and spring struts have been developed. One method involves fork triangulation above the pivot level, or the point that the swing-arm connects to the frame and is allowed to rotate (Foale, 1-23). This pivot point is identified in Figure 12. This design is ideal for a single strut mounted at the apex of triangulation on the fork. An example of this design is the experimental BSA 250cc grand prix racer, built by Doug Hele in 1952, seen below in Figure 16. This bike features a single strut fixed to the top apex of the triangulated fork.

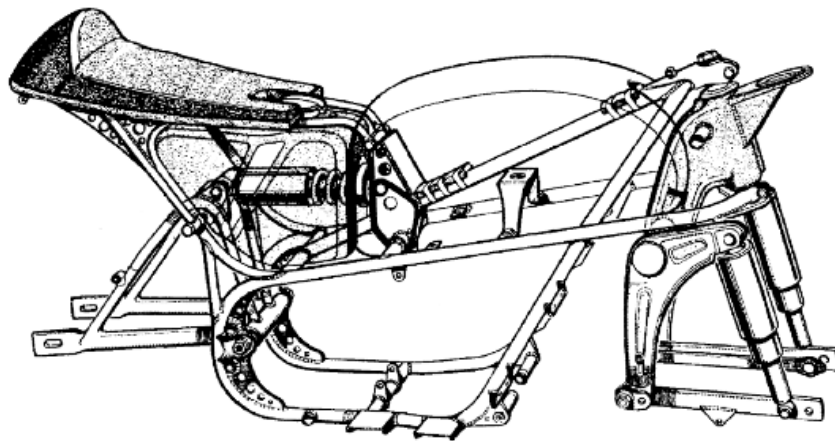

*Figure 16 BSA 250cc grand prix racer (Foale, 1-24)*

Another method is triangulating the fork below pivot level. Suzuki developed several designs using this method from the 1950s through the 1970s (Foale, 1-24). The earlier designs maintained dual struts even with the triangulation, seen in Figure 17, but eventually evolved to a single strut when they developed a new system for their 250 cc grand prix race bikes in the mid-1970s. This design began a trend of rocker-arm rear suspension on road bikes that has continued even until the present day. While they are credited for beginning the trend on road bikes, the first design of this type was utilized on off-road motocross bikes by Yamaha. In Suzuki's early single strut designs, the strut was positioned vertically, behind the gearbox, and anchored to the frame at the bottom end. Forces on the rear wheel were translated to the strut through a rocker arm, which was connected to A-brackets midway along the swing-arm.

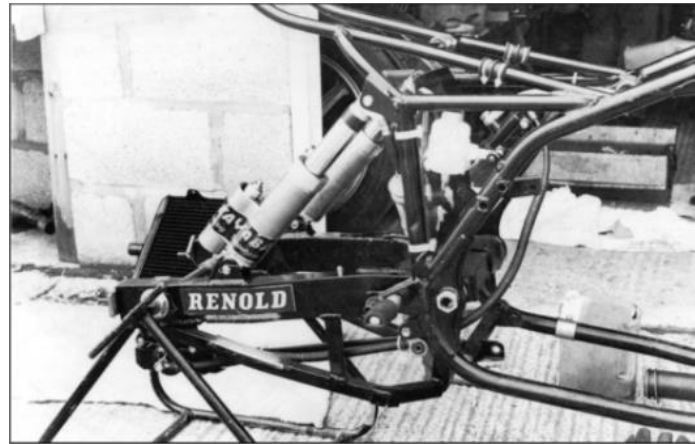

*Figure 17 Rear fork triangulated below pivot on the Suzuki RG500 GP racer (Foale, 1-25)*

Kawasaki took influences from Suzuki's rocker-arm rear suspension design in their development of a system for the KR500 square four. In this design, the swing-arm was triangulated above pivot rather than below (Foale, 1-24). The apex of this triangulation was then connected to a rocker arm by a short upright link. Two gas struts are fitted to this design. The strut was anchored to the swing-arm just below the pivot point, rather than the main frame. This design can be seen in Figure 18 below and features pivot triangulation and a rocker arm to actuate the strut. The black dots represent a fixed point.

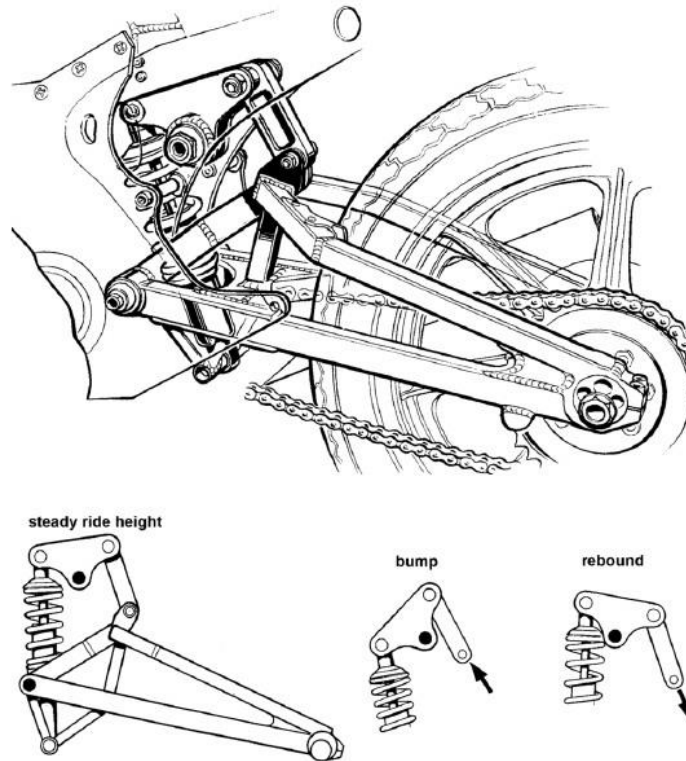
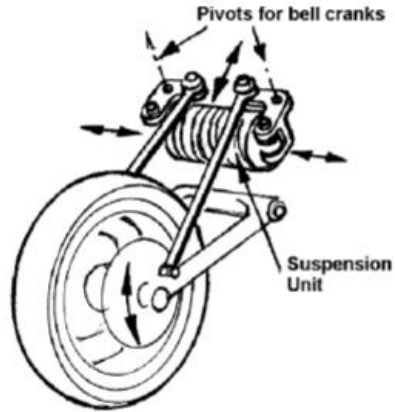

Figure 18 Kawasaki KR500 swing-arm design (Foale, 1-25)

In both the Kawasaki and Suzuki design, the primary goal was to provide progressively stiffer resistance to wheel displacement while using a constant rate spring (Foale, 1-24). In order to achieve this progressive rate at the rear axle out of a linear spring required certain angles of linkages in the suspension geometry. This principle became widely accepted in the industry. However, it was noted that the effect of certain changes in linkage angles tended to cancel each other out. This meant a lot of effort and thought could be put into a complex suspension linkage system that ultimately had the same effect as the spring by itself. For this reason, some designers moved away from this concept and instead incorporated suspension dampers with variable rate springs. This was accomplished by either using two different springs end to end or by using one spring wound to different pitches.

Another unique rocker system was developed by Yamaha, which they began using on their OW61 GP race bikes in 1973 (Foale, 1-26). In this design the strut was mounted horizontally and transversely (forming a 90 degree angle to the rear wheel). This strut was squeezed simultaneously from both ends when the swing-arm encountered forces by two bell-cranks that connected to the top of a triangulated fork. This unconventional design was primarily implemented to save space before and after the strut. This design can be seen in Figure 19 below.



*Figure 19 Unique suspension design on Yamaha OW61 GP racer (Foale, 1-25)*

Since this time of innovation, nearly every racing or sporting road bike has featured a rear swing-arm suspension design that has utilized some form of rocker arm and linkage set up (Foale, 1-26). This type of design allows for minimal space to be used for suspension components, adequate wheel travel, and progressive suspension dampening for the rear wheel.

## 2.4 Current Designs

The current motorcycle suspension design has made a great deal of progress in the recent years. The backbone of the system has, of course, remained the same. There are specific components that must be included in every motorcycle suspension system. However, recently there have been a number of different modifications made to the basic motorcycle suspension design. These various modifications have made the suspension system more effective in specific aspects, such as rider feel, sturdiness, longevity, drag, durability, reliability, control, and ease of use. We see these modifications applied in some of the current motorcycle suspension designs.

The first of these designs that includes specific components in order to make the suspension system more effective is the Parker model. This design is for a system that utilizes a single-sided swing arm suspension, in addition to a control arm. The design also includes a cantilevered wheel axle and an axle bearing assembly as shown in Figure 20 (Parker).

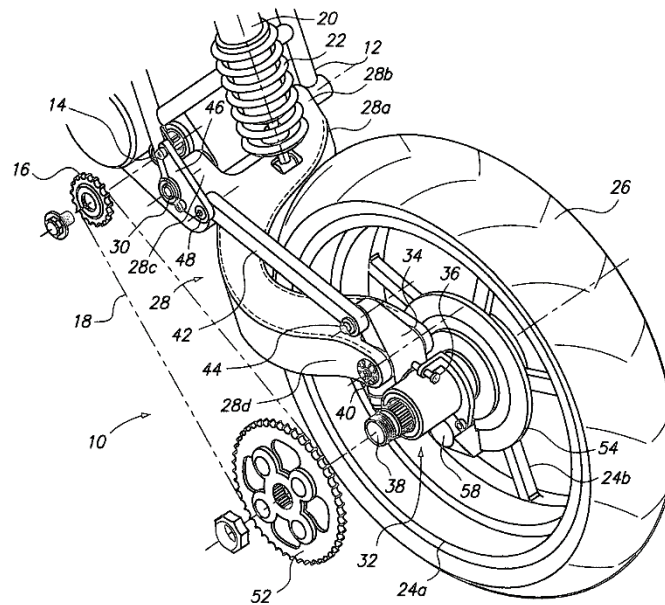

Figure 20 Parker Motorcycle Suspension System Design. (Parker)

Note: 28: Single-sided rear swing arm, 32: Axle bearing assembly, 38: Wheel Axle, 42: Control Arm.

The image above depicts the Parker motorcycle suspension system design. This modified motorcycle suspension system design is effective at making the wheel axle's path of travel more linear, resulting in a stronger barrier keeping propulsion drive forces from reacting on the wheel.

This is beneficial because it allows the bike to travel more steadily, improving the overall rider feel as well as the bike's sturdiness and longevity.

Another example of a modified suspension system design is the dual spring system. This system utilizes primary and secondary torsion springs, in addition to a trailing fork carrying a powered traction wheel, all on the same axis (Cullinan). The springs used are both easily replaceable and adjustable for height and varying loads.

U.S. Patent June 29, 1976 Sheet 1 of 2 3,966,006

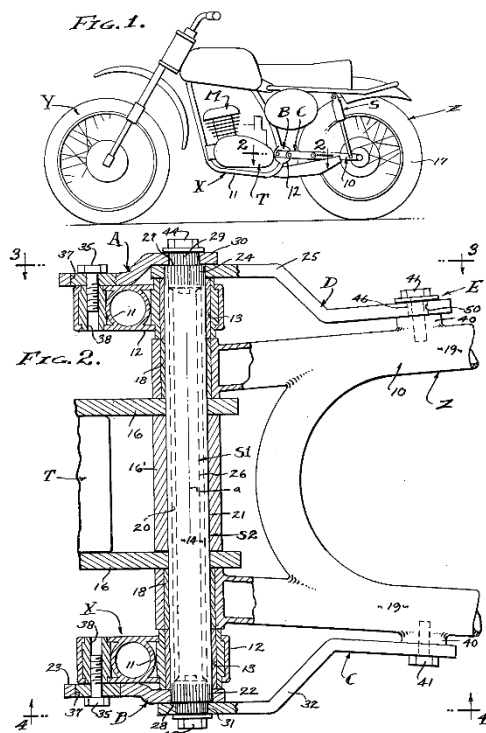

Figure 21 Dual-Spring Motorcycle Suspension System Design. (Cullinan)

Note: S1: Primary torsion spring, S2: Secondary torsion spring, 10: Trailing suspension fork, 17: Traction wheel. The image above in Figure 21 depicts the dual-spring motorcycle suspension system design.

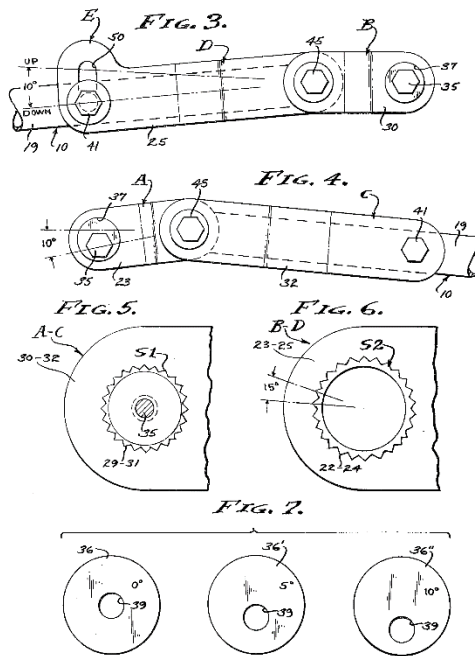

Figure 22 Dual-Springs in a Motorcycle Suspension System. (Cullinan)

The image above in Figure 22 depicts the springs used in a dual-spring suspension system. Because of the way that the springs are applied to this system, the load on this rear suspension system is centralized, the gyration radius is minimized, the unsprung weight is reduced, and traction and ground engagement capability are increased resulting in superior handling (Cullinan). The benefits of a dual-spring suspension system allows motorcycles to drive smoothly with less difficulty and drag.

In addition to this, we have seen systems with rear wheel suspension springs connected to the frame. This component, mainly intended for the application of off-road vehicles, forces any upwards impact on the rear tire to be horizontally reacted on the frame (Macdonald).

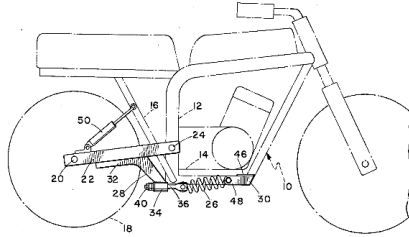

Fig. 1

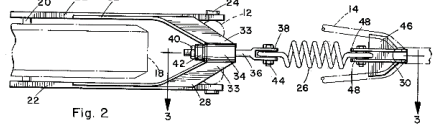

Fig. 2

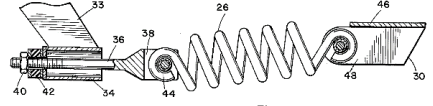

Fig. 3

Figure 23 Design of a System with Rear Wheel Suspension Springs 1 (Macdonald)

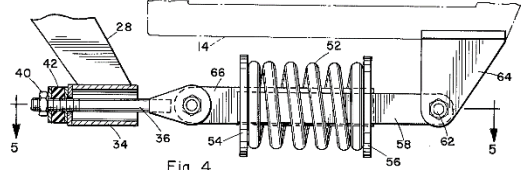

Fig. 4

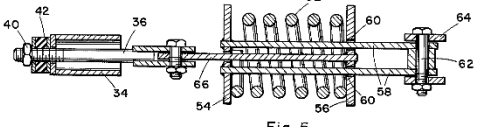

Fig. 5

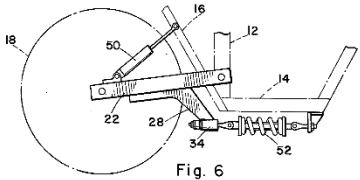

Fig. 6

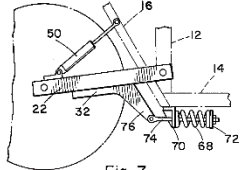

Fig. 7

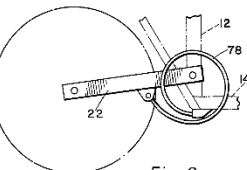

Fig. 8

Figure 24 Design of a System with Rear Wheel Suspension Springs 2 (Macdonald)



The images above in Figure 23 and Figure 24 depict the implementation of a spring component connected to the frame . The application of this spring component to a motorcycle suspension system ultimately decreases the pitching motion and vertical thrust on the back half of the motorcycle. This helps to improve the rider feel, as well as the longevity of the bike.

The next component that we have seen applied to motorcycle suspension systems is a trailing link. Implemented successfully, the resulting link centers can create long pivotal radii for the rear wheel, allowing increased suspension travel (Jarman).

U.S. Patent Nov. 4, 1975 3,917,313

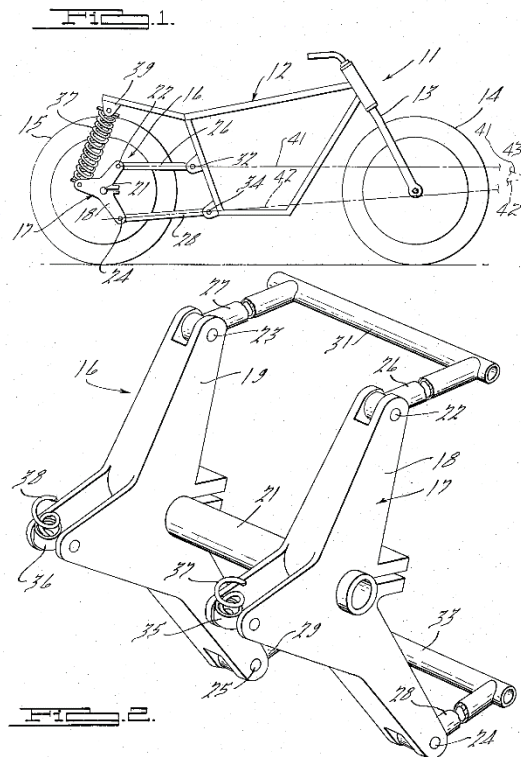

Figure 25 Design of a Motorcycle Suspension System with Trailing Links (Jarman)

Figure 25 depicts the application of trailing links in a motorcycle rear suspension.

Lastly, some modern motorcycle suspension system designs apply shock preload adjusters and shock sag adjustment components by default. Shock preload adjusters are applied to suspension systems so that the shocks can be set for the conditions at which they will be used (Shock Preload). This is simply done by compressing and uncompressing the spring (Shock Preload). In addition, shock sag adjustment allows the shock to function in both directions. In order

to do this, the shock compresses slightly and immediately once the rider is on the bike (Shock Sag). This compression or sag is then adjusted by utilizing the preload adjusters attached to the shocks. The use of shock sags improves both rider feel and durability.

## 2.5 Specifics on CB Suspensions

When the Honda CB750 single overhead-cam was released in 1969, it was hailed by many as the "most sophisticated production bike ever" (Cycle, 33). However, the bike's rear suspension, was very much commonplace for the motorcycle industry at the time. The CB750 did not bring with it a revolutionary suspension design, but instead used parts and techniques that were tried and trusted.

Its rear suspension featured a plain swing-arm, fabricated out of steel tubing that tapered in diameter as the arms extended (Honda, 3). Directly above and in line with the rear axle mounted two 13 inch linear spring struts, one on each side of the swing-arm. The CB750 had a steep front end rake, meaning the front forks were closer to vertical compared to other motorcycles. This, combined with the rear ride height, gave the bike a very short trail of 3.75 inches.

Most other manufacturers setup their motorcycles to have a trail of four inches or more. Longer trail adds stability to a motorcycle, making it easier to hold in a straight line during highway riding. Shorter trail makes a bike less stable, meaning its direction can be changed more quickly and with less effort. However, it can cause tire and suspension wear issues that can lead to erratic high-speed stability (Foale, 1-12).

While the CB750 rear suspension system offered competitive performance when it was released, the advances in technology have left it vastly inferior to modern offerings. However, this model does have a standard rear swing-arm, that is made out of boxed low carbon steel and tubing. Since swingarms are still the standard of the sport bike industry, the CB platform is a good starting point to create an updated suspension system. Also, the design and material of the swingarm make it easy to modify for this new system.

## 2.7 Market

The motorcycle industry has been growing exponentially over recent years. As a result, there has been a major increase in sales both in the US and worldwide. In the US alone, there are 500,000 motorcycles purchased annually (Laporte). With the increasing interest in motorcycles, analysts have estimated the projected motorcycle sales for North America to reach 1,930,000 in 2018. Data collectors have shown that the number of registered motorcycles in the US have been increasing rapidly throughout the years and this is shown in Table 1 (Morris).

*Table 1 Motorcycle Registration and Sales in US (Morris)*

<b>Year</b>	<b>Registered motorcycles</b>	<b>Motorcycles sold (new)</b>
1997	3,826,373	260,000
1998	3,879,450	311,000
1999	4,152,433	394,000
2000	4,346,068	490,000
2001	4,903,056	577,000
2002	5,004,156	640,000
2003	5,370,035	683,000
2004	5,780,870	750,000
2005	6,227,146	831,000
2006	6,678,958	892,000
2007	7,138,476	885,000

**SOURCE:** Motorcycle Industry Council. 2003-2007 Statistical Annuals. Irvine, CA; and U.S. Department of Transportation. State Motor-Vehicle Registrations. Washington, DC. as of Nov. 19, 2008 from <http://www.fhwa.dot.gov/policy/ohpi/qfvehicles.cfm>.

The market has evolved drastically to include both more women and people of older ages. According to studies, in 2009 the median age of all motorcycle buyers was 38, with 8.2% of all buyers being female (Halliday). This data can be seen below in Table 2.

*Table 2 Motorcycle Owners by Age in United States (Halliday)*

<b>Age</b>	<b>Year</b>			
	<b>1985</b>	<b>1990</b>	<b>1998</b>	<b>2003</b>
<18	14.9	8.3	4.1	3.7
18-24	20.7	15.5	10.6	10.8
25-29	18.7	17.1	10.9	7.6
30-34	13.8	16.4	11.5	8.9
35-39	8.7	14.3	16	10.4
40-49	13.2	16.3	24.6	27.9
50+	8.1	10.1	19.1	25.1
Not stated	1.9	2.0	3.2	5.6
Median age	27.1	32.0	38.0	41.0
Mean age	28.5	33.1	38.1	40.2

**NOTE:** Data include owners of on- and off-road motorcycles.

**SOURCE:** Motorcycle Industry Council. Data received by personal communication from J. Goodwin, Sept. 30, 2008. Irvine, CA.

Harley Davidson is a very well-known name in the motorcycle industry. Harley Davidson Motor Company is the leading motorcycle company in the entire industry and it has been very difficult for any other company to produce nearly as much revenue as Harley Davidson Motor Company produces. However, Honda Motor Company has distinguished itself as a key competitor to Harley Davidson Motor Company. Honda has sold 17 million motorcycles worldwide and 308,000 motorcycles in North America alone (Laporte).

The data collected above indicates to us that Harley Davison bikes may just be too expensive for our market. Since the amount of motorcycle registrations have been increasing along with both the median age of motorcycle owners and number of Harley Davidson bikes sold, it can be assumed that most of the motorcycles being bought are more expensive bikes for wealthier individuals. Our projected market for our project is younger individuals, which we believe will appreciate the application of our modified suspension system to a Honda CB model. These types of bikes are much more affordable and suitable for the younger market.

## 2.8 Current Solutions

When considering creating a new product, it is imperative to first check any commercially available products that are targeted at meeting the same demand. This will help answer the question “is there room in this segment for a new product.” It will also help reveal any patents that may limit the design options. After the products are all identified and researched, checking for generic patents will help establish prior art, as well as limit the possibility of patent infringement in any future designs.

The only product we were able to locate in this segment was the "CB Suspension conversion kit" by Kinetic Motorcycle, which can be seen in Figure 26 and Figure 27 below.



*Figure 26 Kinetic Motorcycle suspension kit installed on frame with two shocks*



*Figure 27 CB750 with Kinetic Motorcycle suspension kit*

This conversion kit costs \$650 USD with the shock not included. Kinetic Motorcycle provides the following specifications for this product:

- All CNC cut to specific application.
- Adjustable height and length.
- Fits most 10" to 12" eye-to-eye shock.
- Doesn't interfere with wider tire fitment.
- Steel frame and swing-arm tabs.
- Chromoly steel bracing.
- Shock brace with adjustable end-links.
- Vertical support brace with adjustable end-links.
- Upper shock brace with wiring slots and mounting gussets.
- Detailed instruction guide.
- Fit Models CB500/CB550/CB650/CB750

While this product makes the rear end of the Honda CB less cluttered and much cleaner appearing, it does not offer much in terms of performance gain. This design utilizes a swing-arm triangulated above pivot with either a single shock, or paired shocks, that connect to the center of this triangulation and then to the frame. However, this triangulation connects to the swing-arm very close to the rear axle, maintaining the ratio of wheel travel to strut compression close to the stock system. This means that the strut, or struts, in this design must still travel through a long stroke, which could make the system prone to suspension fade due to the fact that the fluid and springs in the struts are being compressed very frequently under greater forces than a lower wheel to compression ratio. Also, because the struts have such a long stroke, they are likely to wear faster than they would in a system that utilized a shorter stroke.

### 3. Methodology

The goal of this project was to design and create an affordable modular suspension system that improves the performance of Honda CB motorcycles. We created ten objectives to complete this project. They are:

1. Determine suspension system requirements and specifications
2. Create preliminary designs;
3. Evaluate designs and select the three best candidates;
4. Create 3D models of designs and analyze;
5. Select best design based on analysis;
6. Iteration of design;
7. Prototype most suitable design;
8. Physical analysis of suspension system.

The methods below were designed to help us achieve these objectives.

#### 3.1 Determine Suspension System Requirements and Specifications

Like most design undertakings, creating design requirements and specifications was crucial in aiming our efforts to a specific set of goals. Design requirements outline the essential characteristics the design must meet in order to ultimately be successful. They constrain potential solutions. While design requirements are vital, the course of research and design can dictate unforeseeable changes, and the original requirements must be adjusted accordingly. Once completed, these steps design requirements allowed us to move forward and begin to create preliminary designs.

#### 3.2 Create Preliminary Designs

There are many different methods of designing a rear suspension system. Even a rocker-arm style rear suspension system, which is currently the most prevalent and one of the most highly regarded systems, can be designed in many different ways. For this reason, it was imperative for us to create a wide range of preliminary designs.

The first step in this process was to compile measurements of CB rear swing-arms and frames, as well as clearance between the rear wheel and the swing-arm. This data was necessary in order to determine the dimensions that confined our designs, and to determine potential



mounting points. These measurements were obtained by measuring our specific motorcycle, a 1981 Honda CB750k.

With the confining dimensions determined, several preliminary designs were created that could potentially meet our requirements. These designs focused on the fundamentals of linkage systems, ensuring that the proposed system would deliver the desired range of motion. All of these designs were then compared to determine the most viable options.

### 3.3 Evaluate Preliminary Designs

Our third objective was to evaluate our preliminary designs and select the top three candidates. Our decision matrix in this process considered the following: appearance, machining required, and performance. We considered appearance as an important factor because our target customers value the appearance of their motorcycle almost equally to the performance of it. Therefore, if a product does not reflect this, they will not be inclined to purchase it. We were also attentive to the amount of machining required. We knew that this would impact not only the cost and time required to assemble the system, but also the expertise that the system required. The last parameter that we considered when choosing our top three candidates was the performance of the system. This was determined by the progressiveness of the suspension and how much rear wheel travel it allowed for. The best performing system would be one that achieves similar characteristics in these areas to a modern sport bike. This was our most important criteria as our ultimate goal was to improve the rear suspension on the motorcycle.

After determining each of these relevant parameters, we were able to evaluate each preliminary design in order to narrow the modeling process to include the best three designs. It is important to note that all of these parameters utilized estimated values. However, they did allow us to make a more educated decision about which designs would be the most effective in achieving our goal statement while also meeting our design requirements.

### 3.4 3D Modeling and Analysis of Designs

Once we selected the three best designs, we needed a more objective way to test them. In order to accomplish this we used the computer aided design software, SolidWorks. First, the frame and swing-arm of our specific CB motorcycle was created in the software. This allowed us to ensure that the 3D designs would fit to the existing equipment, as well as gave us a complete system to test our designs. When all the designs were rendered, each one was attached to a rendering of the frame and swing-arm as an assembly in SolidWorks.

These assemblies allowed us to specifically test the range of motion of each system, as well as evaluate any potential interferences. Furthermore, we were able to stress test the systems using the analysis software available in SolidWorks. This gave us more concrete data to justify pursuing one design over the others.

### 3.5 Final Design Selection

To determine the suitability of each design, we created a decision matrix. This matrix included categories that were ranked 1 through 10 based on how important we determined they were. Each design was then ranked 1 through 10 in each of these categories. To determine a design's final score, each category score was multiplied by that category's respective ranking. Then all the final category scores were totaled together. The highest scoring design was then selected for prototyping.

The categories included in the decision matrix were performance, cost, and appearance. Performance ranked the highest with a score of 10, because our suspension system needed to perform better than the stock system for it to be a viable upgrade for consumers. The performance scores for each system were based off of digital analysis to examine range of motion and progressiveness. The top score possible was awarded if the system matched a modern sport bike's rear suspension performance.

The next category was appearance with a ranking of 8. Ultimately the goal for our product was not only to improve suspension performance of these motorcycles, but also the appearance. While appearance is an extremely subjective metric, it is generally accepted in motorcycle design that a compact suspension system that creates open space between the swing-arm and the frame is more attractive. We used this criteria, as well as our own personal opinion of the appearance of each mechanical system to determine a score for each design.

The third category was cost with a ranking of 7. This cost represents the price required to produce the design. This includes material, labor, manufacturing, and part cost. While cost is an important category, and ultimately determines the final price of the product, it received the lowest ranking because price is normally not the most important factor for consumers when purchasing after-market parts. Although many consumers in this market value performance and quality over affordability, if our design required too much machining for installation, it would be an extremely prohibitive product.

Once all of the scores were calculated and the ratings for each system were totaled, the highest scoring design was selected. We then reviewed the design for any final adjustments and began prototyping.

### 3.6 Initial Prototype Iteration of Designs

Once we had selected a final design, we iterated it to improve performance to ease the manufacturing process. The first step in this process was to create a physical model. This model allowed us to test our design and check any potential interferences. Based on these tests, the 3D model was adjusted, and the changes were made to the physical model as well. Once we were satisfied with how the physical model interacted with our motorcycle, we moved toward manufacturing our final design.

### 3.7 Prototype Design

Our next objective was to prototype the most suitable design. This involved three major steps: purchasing required parts, creating computer aided machining (CAM) files, and machining and fabricating the necessary parts. Since we wanted our suspension system to be easy to maintain, we attempted to use as many off-the-shelf parts as possible. We also took this approach in order to lower the cost of our production. Once all of the parts were either purchased or manufactured, we assembled and installed the system on the 1981 Honda CB750K.

## 4. Analysis and Findings

### 4.1 Determine the Suspension System Requirements

Our first objective was to determine suspension system requirements. In order to do this, we researched integral components and factors of suspension systems and made sure that our suspension would include the necessary specifications. We also researched the evolution of motorcycle rear suspension systems. This allowed us to understand how different systems function, how performance is determined, and what techniques are used by the top manufacturers today. This research can be found the Background of Chapter 1. Once this research was completed, we determined our system needed to meet the following design requirements:

1. Fit all Honda CB750 models from 1970-1989;
2. Machined parts will have infinite life, or survive  $10^6$  cycles for materials without infinite life, with application of expected loads;
3. Bike will pass mv inspection with parts installed
4. Use an existing shock from a modern sport bike without any revalving or part changing;
5. Cost no more than \$1000 with shock and professional installation;
6. Improve the appearance of the motorcycle;
7. Multi-point adjustability for customer tuning;
8. Minimal installation requiring no more than 6 weld-on tabs;
9. Provide progressive suspension response;
10. Incorporate readily available bearings;
11. All parts are corrosion resistant;
12. Easy maintenance, including joint and bearing greasing as well as shock and other part replacement.

These design requirements guided our design and manufacturing decisions over the course of the project.

## 4.2 Create Preliminary Designs

Next, we created six preliminary designs that could potentially meet our design requirements. These designs were inspired by both past and current designs utilized by the motorcycle industry. Initially, these designs were sketched by hand to understand how the basic geometry of the system would be laid out. Once the design was sorted by hand, it was drawn in 2D using SolidWorks.

The first design can be seen in Figure 28 below. This system utilizes a triangulated link above pivot level that rotates a rocker link about a fixed pivot in order to compress the spring. In this design, the frame is connected to the rocker pivot rather than the spring. The advantage of the rocker in this design is that it reduces the stroke of the spring while increasing rear wheel articulation. In Figure 28, the black lines represent the frame of the motorcycle, while the blue lines represent the suspension system including the swingarm and tire. The vertical blue line to the left is the spring, while the one to the right is the link. The blue triangle is the rocker link and the black dot at the bottom point is the pivot.

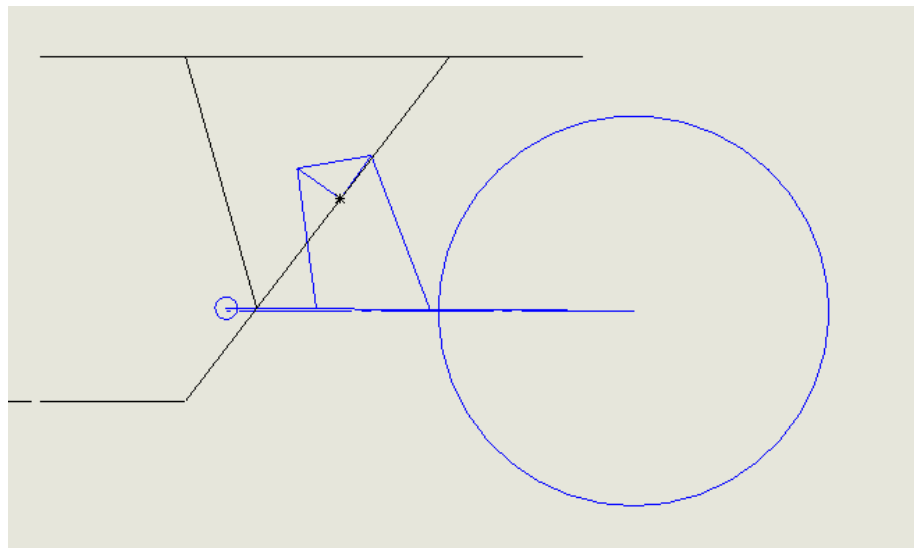

*Figure 28 2D Drawing for Preliminary Design 1*

The second design can be seen in Figure 29 below. This system utilizes a triangulated link above pivot level that connects directly to the spring. The other end of the spring is then connected to the frame. This design moves the spring significantly more forward and upward than the stock system. In Figure 29, the two blue lines that meet in a point over the swingarm is the fixed link. They represent fixed rods that are rigidly connect to the swingarm. The blue line that connects to the point is the spring.

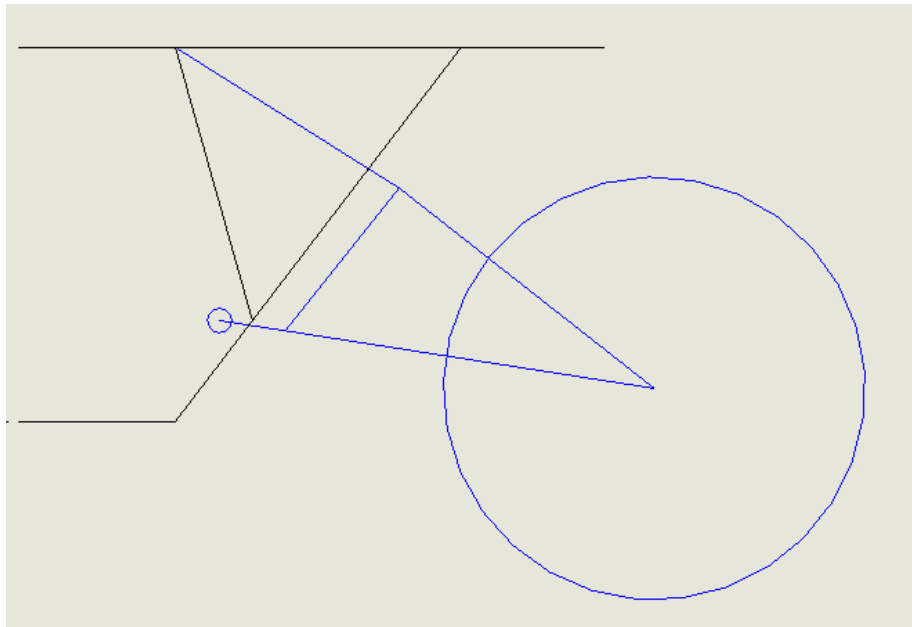

*Figure 29 2D Drawing for Preliminary Design 2*

The third design can be seen in Figure 30 below. This system utilizes a triangulated link below pivot level that rotates a rocker link about a fixed pivot in order to compress the spring. In this design, both the rocker pivot and the spring are connected to the frame. The advantage of the rocker in this design is that it reduces the stroke of the spring while increasing rear wheel articulation. In Figure 30, the vertical blue line is the spring, while the lowest one is the link. This bottom link translates motion from the wheel to rotation at the rocker link. The blue triangle is the rocker link and the black dot at the top point is the pivot.

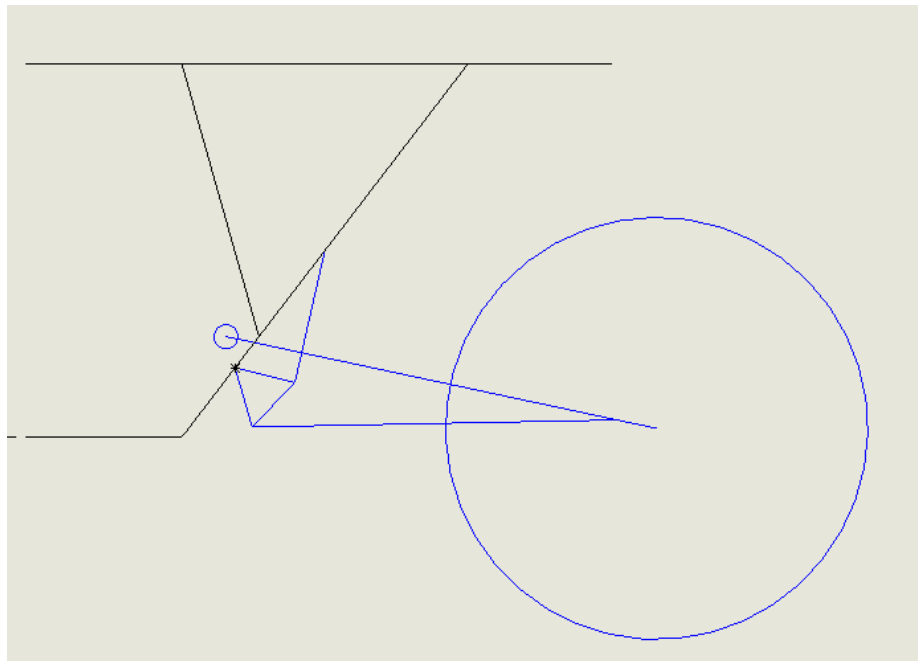

*Figure 30 2D Drawing for Preliminary Design 3*

The fourth design can be seen in Figure 31 below. This system utilizes a link below pivot level translates the motion of the rear wheel to rotate a rocker link about a fixed pivot to compress the spring. In this design, both the rocker pivot and the spring are connected to the frame. Also, in this design both of these components are significantly lower than the other designs. This lowers the center of gravity, but also exposes the system to more road debris and potential interference. In Figure 31, the long vertical blue line is the spring, while the shorter one is the link. The blue triangle is the rocker link and the black dot at the top point is the pivot.

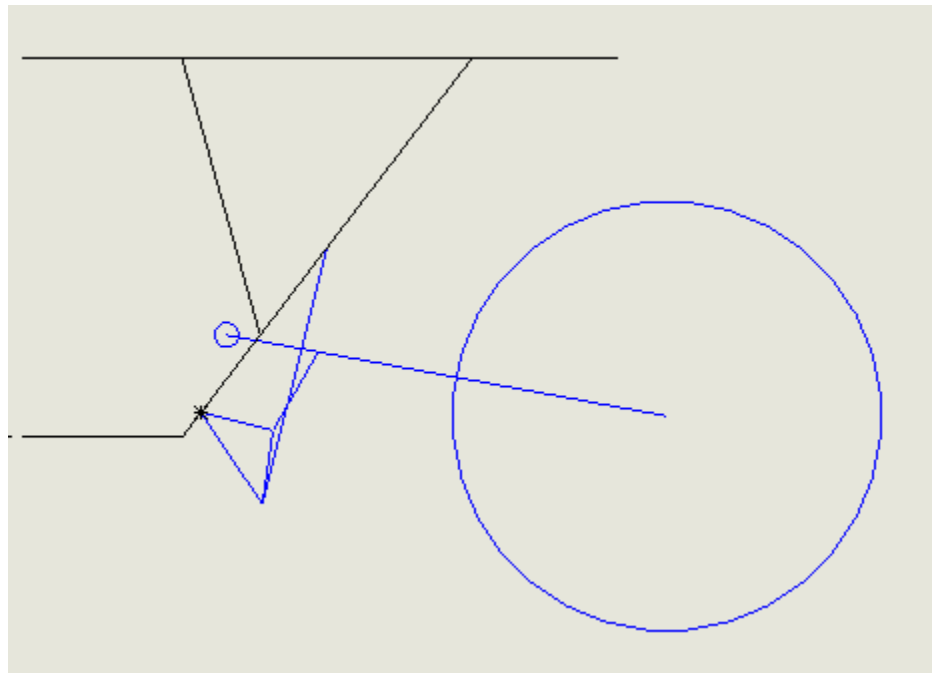

*Figure 31 2D Drawing for Preliminary Design 4*



The fifth design can be seen in Figure 32 below. In this design, both the linear link and the spring are connected to the frame. These both then connect to different points on the rocker link, which is connected to the swingarm. This system works with the same concept of the other rocker systems; however, it has all components mounted below pivot level. This means that, similar to Design 4, it has a lower center of gravity but exposes the system to more debris. In Figure 32, the horizontal blue line connected to the middle of the rocker link is the linear link, while the lowest horizontal blue line is the spring. The blue triangle is the rocker link.

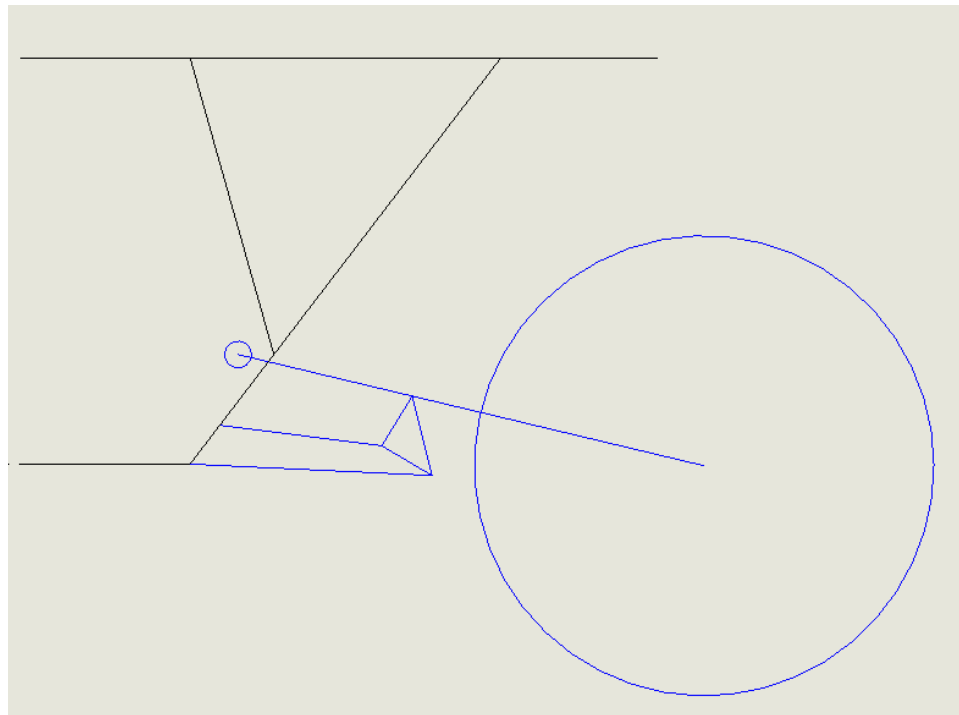

*Figure 32 2D Drawing for Preliminary Design 5*

The sixth design can be seen in Figure 33 below. In this design, both the linear link and the spring are connected to the frame. However, both of these require fixed members to be added to the frame. This is in order to move the mounting points to the desired location. Both the linear link and spring then connect to different points on the rocker link, which is connected to the swingarm. This is similar to Design 5 but moves the spring upward so that it is less likely to be affected by road debris or interference. In Figure 33, the vertical blue line connected to the middle of the rocker link is the spring, while the lowest horizontal blue line is the linear link. The blue triangle is the rocker link.

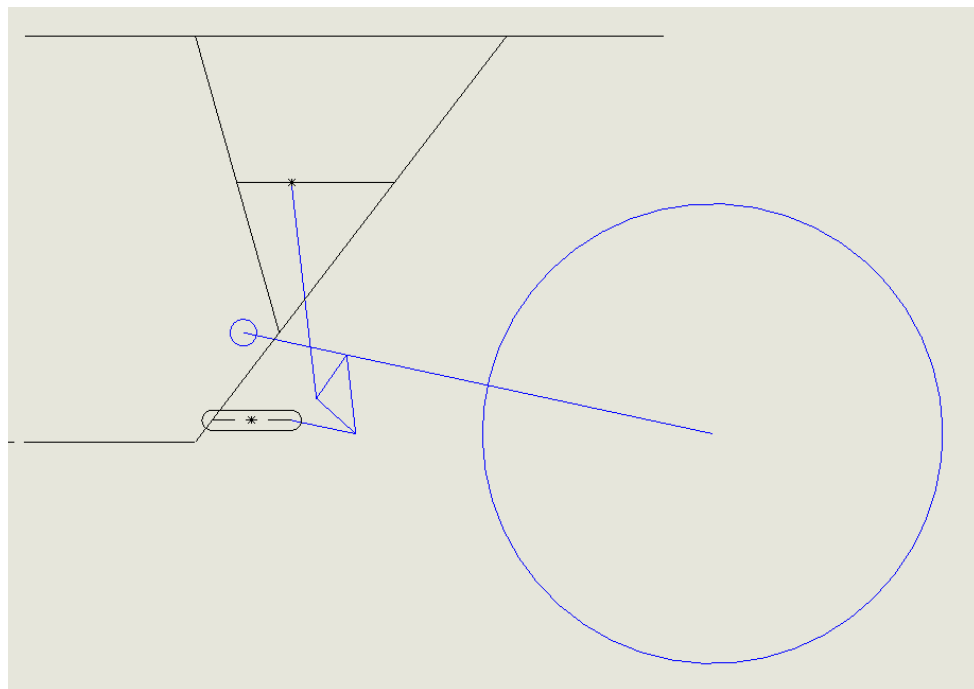

*Figure 33 2D Drawing for Preliminary Design 6*

### 4.3 Evaluate Preliminary Designs

The suspension system's geometry has a great effect on how the system performs and reacts to forces. Small changes in the layout can create a system that is progressive, regressive, or a combination of both. For our design, we desired to create a progressive system, meaning the suspension becomes increasingly harder to compress as the wheel moves upward. In order to ensure our prospective design achieved this, we analyzed how the leverage ratios changed throughout the range of motion in our design. These values then allowed us to calculate the relationship between the wheel rate and wheel displacement. The principal that the wheel rate is equal to the spring rate divided by the square of the Velocity Ratio (VR) applies to all suspension formats. We calculated the VR for each of our six designs by using the equation below.

$$VR = \frac{Lw}{Ll} * \frac{L2}{L1}$$

$Lw$ ,  $Ll$ ,  $L1$ , and  $L2$  correspond to different measurements identified in Figure 34 below from *Motorcycle Handling and Chassis Design* by Tony Foale.  $Lw$  is the horizontal measurement from the rear axle to the center of the swingarm pivot.  $Ll$  is the measurement from the linear link to a parallel line drawn through the center of the swingarm pivot.  $L1$  is the measurement from the spring to a parallel line drawn through the center of the rocker pivot.  $L2$  is the measurement from the linear link to a parallel line drawn through the center of the rocker pivot.

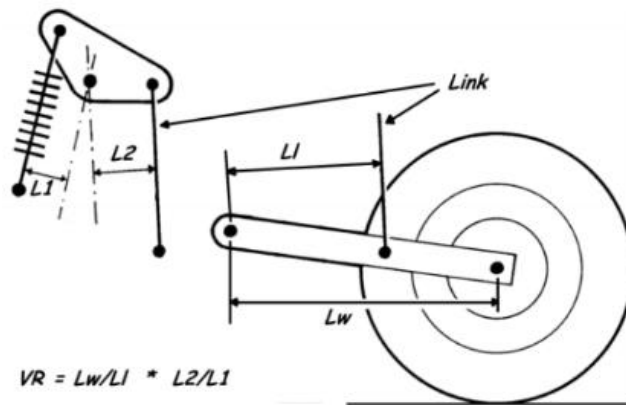

Figure 34 Geometric Considerations for Progressiveness (Foale, 8-8)

With VR calculated, we were able to calculate the effective wheel rate for each design using the equation below.

$$\text{Wheel rate} = \frac{\text{spring rate}}{VR^2}$$

For each system we used a spring rate of 100N/mm. This is the spring rate provided by Yamaha for the spring that we planned to use in these designs. We then plotted the wheel rate, which depicts the overall progressiveness of the system with respect to rear wheel displacement for each design in the charts below.

In order to evaluate the performance of each design, we needed data on modern sport bike performance. Our goal was to create a system that brought performance to the CB 750 that was as close as possible to the modern level. We were able to gather information from several suspension technology companies as well as the manufacturer on the performance of the 2016 Yamaha R6, arguably one of the best 600cc sports bikes available today. According to the specifications sheet provided by Yamaha, the 2016 R6 has a rear wheel travel of 120mm (Yamaha, 2016). The rear wheel rate compared to wheel displacement for this motorcycle can be seen in Figure 35 below. This graph from information provided by SuspAct North America.

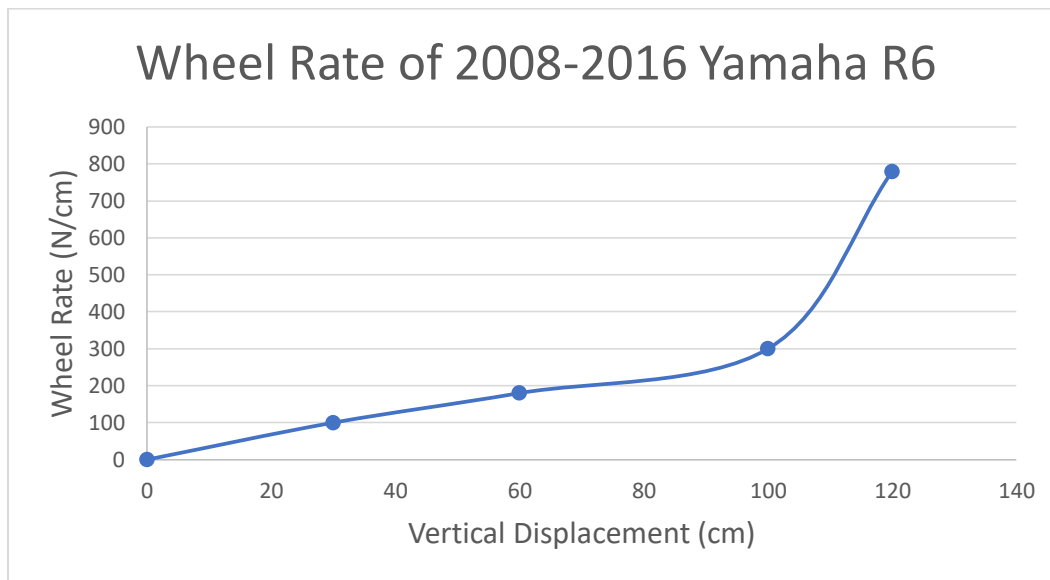

Figure 35 Benchmark - Wheel Rate for 2008-2016 Yamaha R6 (SuspAct, 2018)

The wheel rate-wheel displacement relationship for Design 1 can be seen in Figure 36 below. This system provides a progressive suspension response. The wheel rate in the beginning of the stroke is low, and as the wheel is displaced from its neutral position, the wheel rate gets progressively higher. This equates to a softer feel for smaller bumps for the rider at the beginning of the stroke, and a much firmer feel for large displacements. The main disadvantage of this design is the regressive section from 0 to 20 mm of wheel displacement. This section would need to be at least linear to provide similar performance to the Yamaha R6. However, this is achievable by changing the geometry of the system until the desired results are achieved.

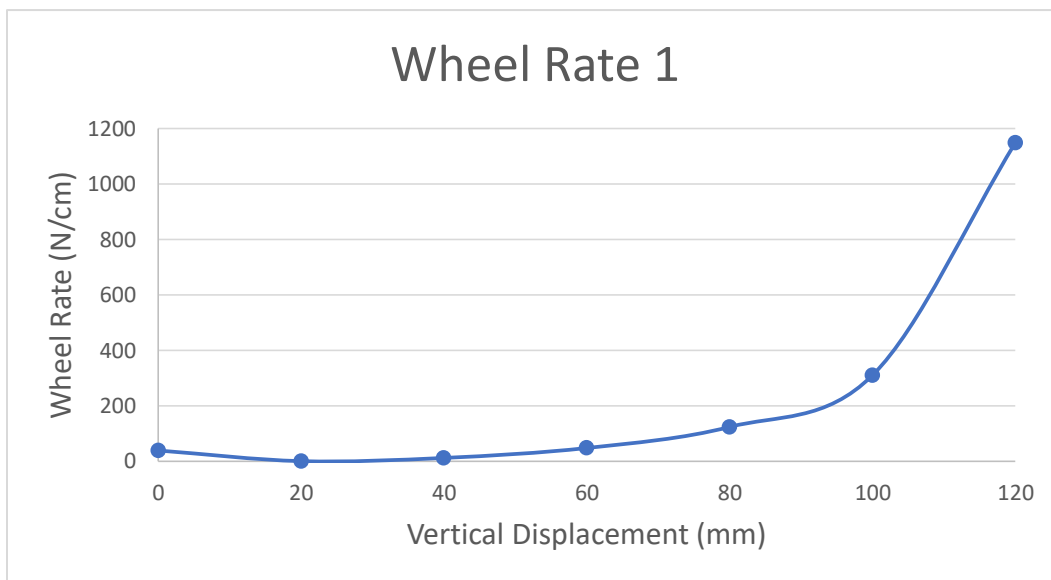

Figure 36 Wheel Rate for Design 1

The graph shown in Figure 37 below shows the wheel rate characteristics for Design 2. This is a regressive system and would result in a stiff suspension response in the beginning of the stroke and a softer response at the end of the stroke. While this general set up could potentially be changed until the geometry resulted in a response similar to the R6, the poor starting point does not encourage this effort.

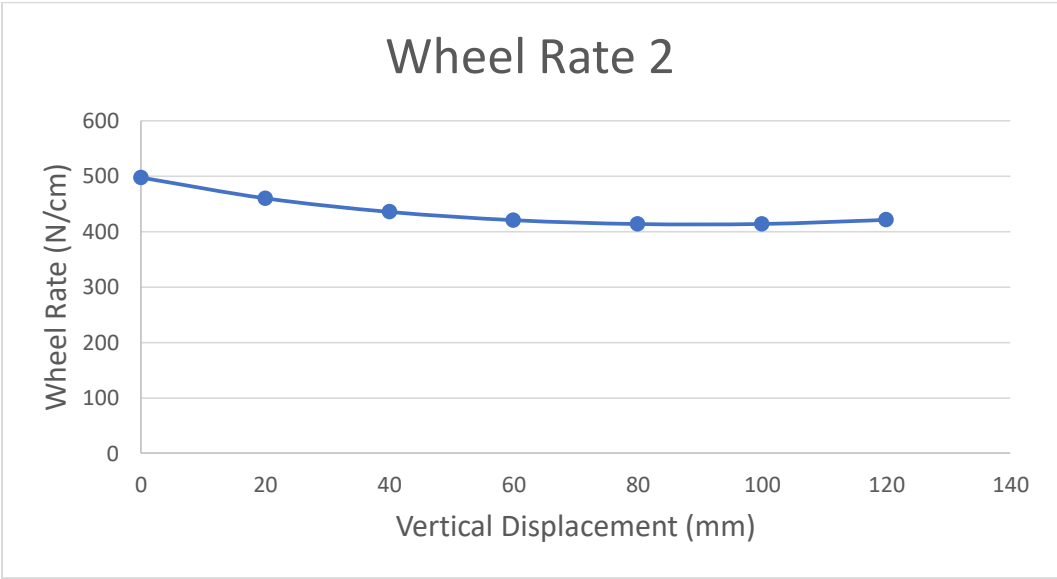

Figure 37 Wheel Rate for Design 2

The graph shown in Figure 38 below shows the wheel rate characteristics for Design 3, which is a regressive suspension system set-up. This provides the same undesirable characteristics as Design 2. While this general set up could potentially be changed until the geometry resulted in a response similar to the R6, the poor starting point does not encourage this effort.

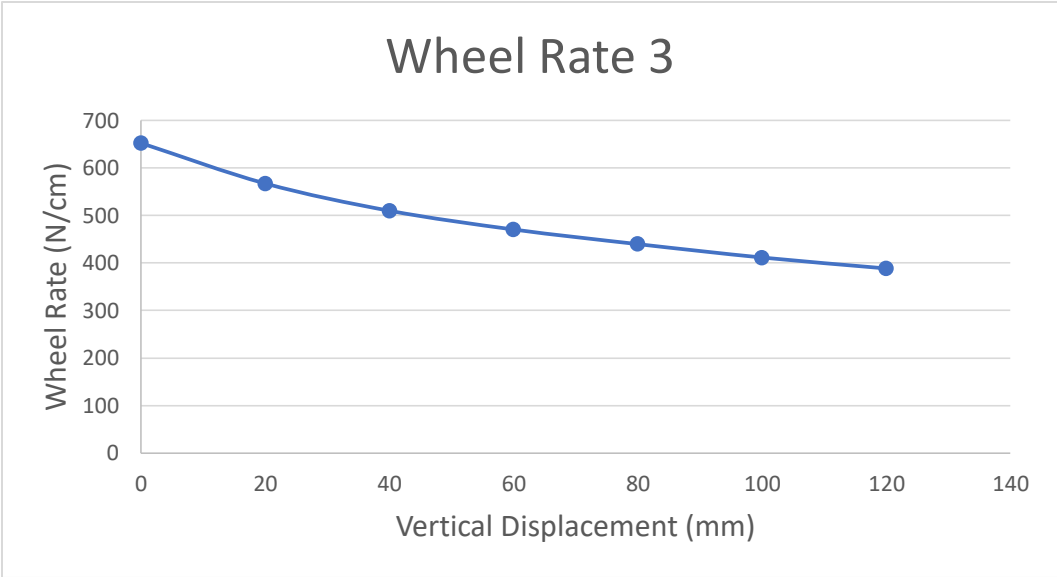

Figure 38 Wheel Rate for Design 3

The wheel rate-wheel displacement relationship for Design 4 can be seen in Figure 39 below. This system provides a mostly linear response. While this characteristic does not necessarily equate to poor performance, it does not match the progressive nature of the R6. However, the graph does show that it is slightly progressive, which indicates that slight changes to the system could enhance this characteristic.

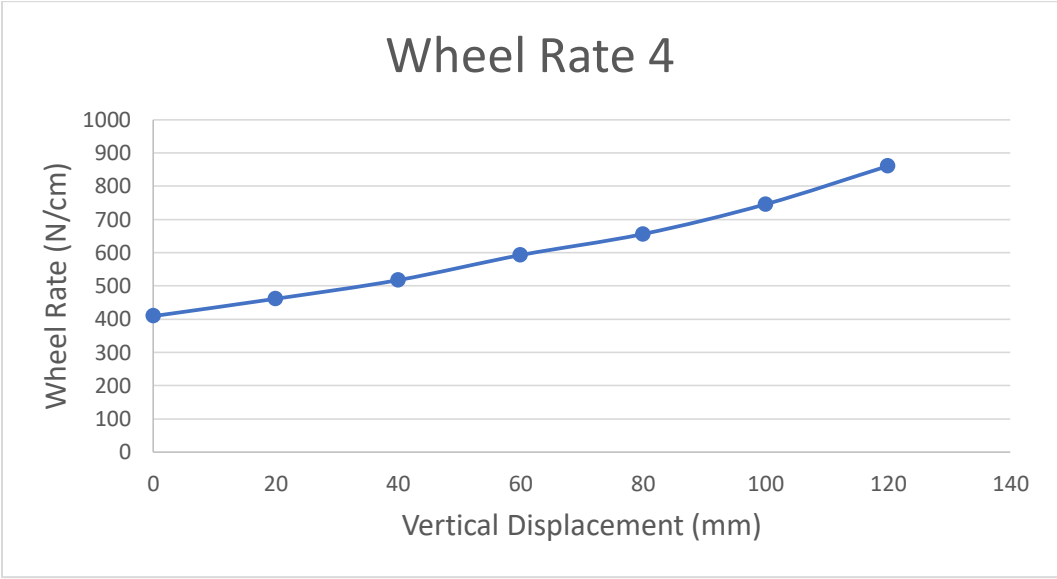

Figure 39 Wheel Rate for Design 4



The graph in Figure 40 below depicts the wheel rate relationship for Design 5. This design creates the most progressive response and has a wheel rate- displacement curve that is very similar to the Yamaha R6. The only disadvantage to this design is that the wheel rate is considerably lower than the Yamaha, with a maximum rate of about 190N/cm compared to 780 N/Cm. This can be corrected by using a shock assembly with a higher spring rate. The spring rate used to create the relationship depicted below was 100N/mm. Springs are available up to about 300 N/mm. This spring would give this system a maximum rate that is still smaller than the R6, but the values for displacements from 0 to 100 mm would be very similar.

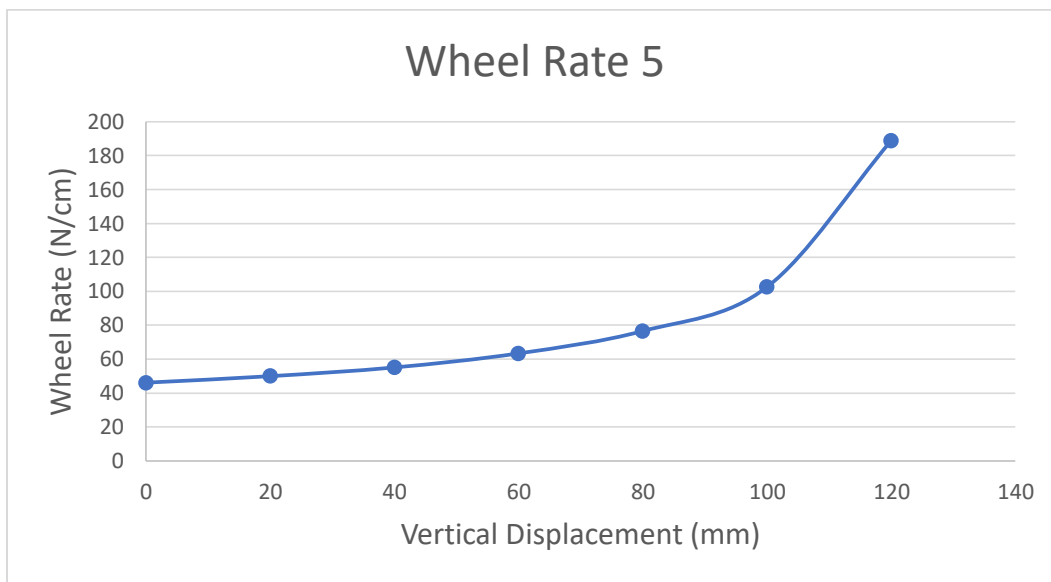

Figure 40 Wheel Rate for Design 5

The graph in Figure 41 below depicts the wheel rate characteristics for Design 6. This is a combination of a progressive and regressive system. With the progressive part of the curve presenting at the beginning of the curve rather than the end, this system would not provide desirable suspension characteristics. Ultimately this design would require too much reworking to make it a viable performer.

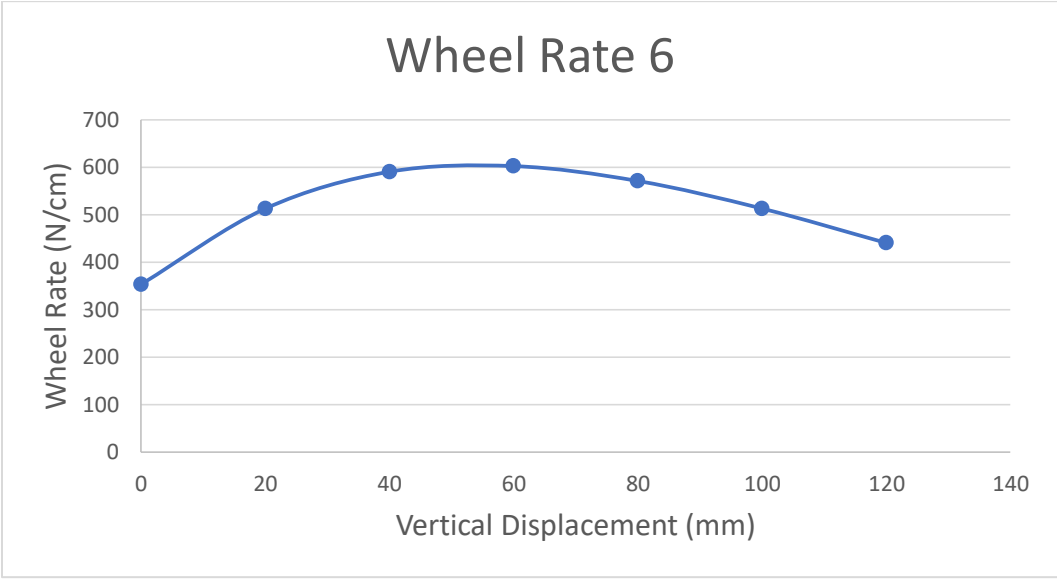

Figure 41 Wheel Rate for Design 6

With the performance graphs created, the final two sections to evaluate these designs in were appearance and cost. Appearance was determined by general consumer trends, and our own subjective opinions. Manufacturability was determined by how many parts would have to be created, how parts would be attached to the motorcycle, and how extensively the frame and swingarm had to be modified. These categories were then given weights and each design was given a score in each of these categories. These values were then used to create the decision matrix seen in Table 3 below.

*Table 3 Preliminary Decision Matrix*

	Design 1	Design 2	Design 3	Design 4	Design 5	Design 6
Performance (10)	8	2	2	7	8	4
Manufacturability (8)	8	8	4	6	7	3
Appearance (7)	8	5	5	7	7	8
<b>Total Score</b>	<b>200</b>	<b>116</b>	<b>87</b>	<b>168</b>	<b>185</b>	<b>125</b>

With the results of this decision matrix we were able to narrow our potential designs down to three: Design 1, Design 4, and Design 5.

## 4.4 3D Modeling

After selecting the most viable three options from our preliminary 2D designs based on theoretical progressiveness, we began 3D modelling these designs to physically see how the suspension would work in 3D space and to check on geometric constraints. To begin this process, we first modelled the rear of portions of the frame, swingarm, and tire. Once this was completed we modelled each individual design.

In Figure 42 below, you can see the suspension system with the shock connecting to the linkage below the swingarm. Although a progressive system with a good range of motion, this design has one major limitation. This limitation is that the customer would have to substantially alter the swingarm in order for the spring to be able to mount to linkage and the frame. This alteration would consist of removing material from the swing arm and since this would be an after-market change, we would not be able to guarantee the safety of these swingarms in withstanding normal riding. With this exception, physical installation of the system would otherwise require six welded tabs.

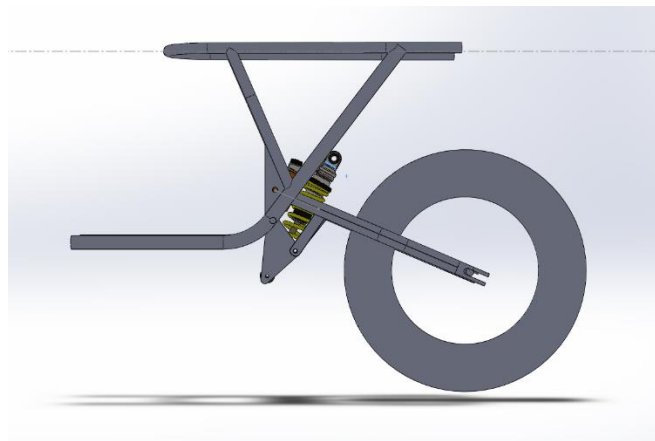

*Figure 42 3D Model of Design 4*

Below in Figure 43, you can see the 3D model for our Design 5. This design offers fewer physical limitations but there is one major performance limitation. Although this system is progressive, the beginning of the stroke actually lengthens the shock instead of compressing. This could be alleviated via substantial shock compression upon installation, however this limits the range of motion of the shock. Additionally, installation would be otherwise very manageable and require six welded tabs.

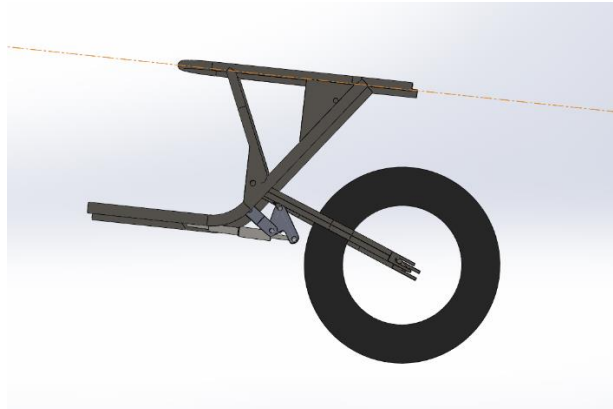

*Figure 43 3D Model of Design 5*

Below in Figure 44 is the 3D model for our preliminary version of Design 1. This is a manageable design in terms of manufacturability as it only requires six welded tabs without any alteration of the swingarm. This system is also a progressive design and compresses the shock throughout the full range of motion of the rear axle.

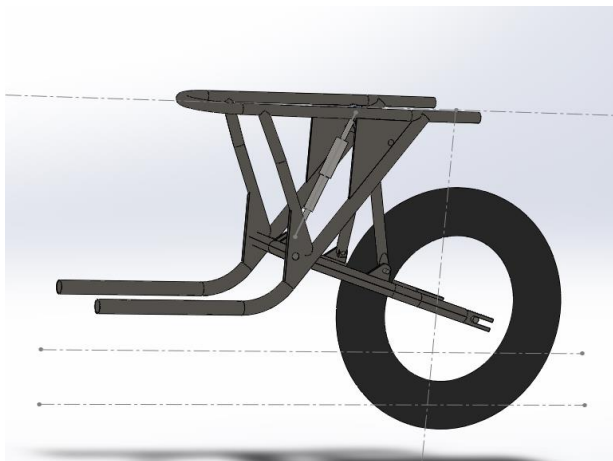

*Figure 44 3D Model of Design 1*

## 4.5 Final Design Selection and Initial Analysis

Ultimately, in accordance with our findings from the decision matrix earlier, and the results of our 3D modelling we moved forward with analyzing our Design 1.

We also needed to physically design this system to be able to withstand maximum compressive forces that the suspension could be subjected to. These forces were determined to be equivalent to the load required to fully compress a modern motorcycle shock with standard spring rate of 100N/mm, combined with the Wheel Force that we calculated for our performance analysis. After determining which design we were going to move forward with, we performed an initial stress analysis using SolidWorks simulation studies. We determined that there were two forces acting on the system: the Wheel Force, determined from the wheel rate at maximum compression, and the Spring Force which is the reactive force from the springs compression of its maximum capacity. Our spring's maximum compression is 30mm which therefore gives us a spring force of 3000N. The wheel force that we calculated in the equation below gives us the wheel force in the system of 250N.

$$\text{Wheel Force} = \frac{\text{Spring Force}}{VR}$$

We placed these forces in their respective locations and directions in our 3D model and ran a SolidWorks simulation for Safety Factor due to Von Mises Effective Stresses and Deformation.

Below in Figure 45 shows the Safety Factor due to Von Mises Effective Stresses. Our results show a safety factor less than industry standard around the center pivot hole on the main link. This is due to a sharp stress concentration. To alleviate this, in a future design we will add on both a small fillet to relieve these stresses, and a sleeve bearing rated to the appropriate capacity.

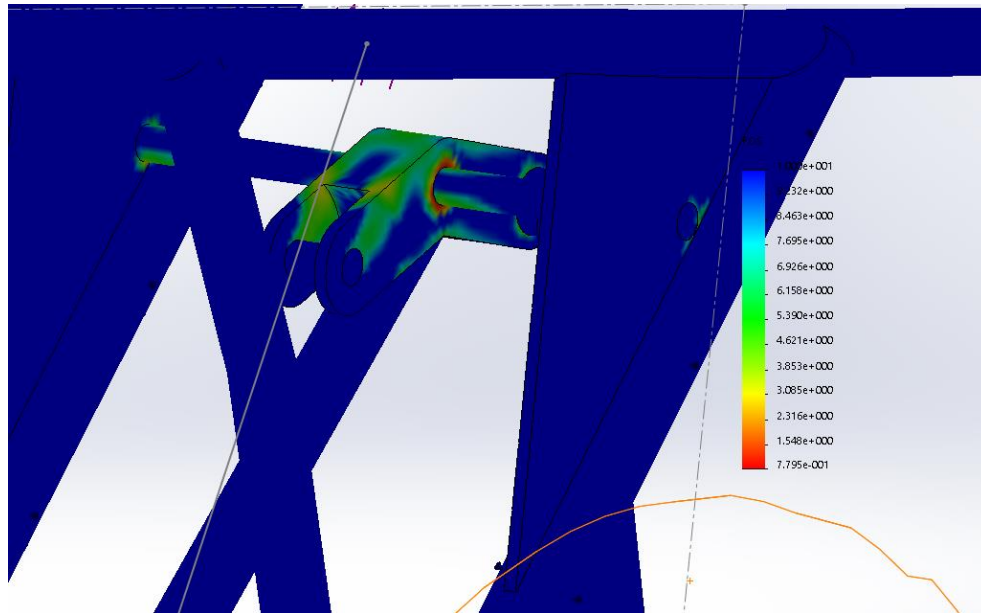

Figure 45 Safety Factor for Von Mises Stresses

Secondly, the simulation seen below in Figure 46 shows the deformation of our system under maximum loading. The only area that showed drastic deformation in our 3D model was the end of the swing arm where the rear axle is located. Ultimately, we decided that this would not be a problem for us and determined that this is caused by our under-modelling the swing arm in our model. In real life application, these swingarms are taken directly from the bike being modified which is designed by Honda per industry standard to accept the forces appropriately.

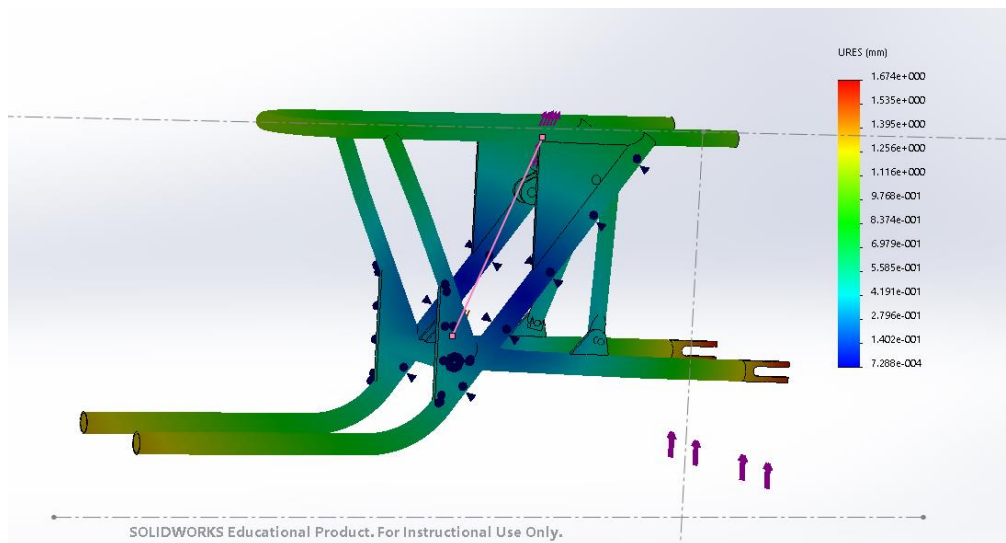
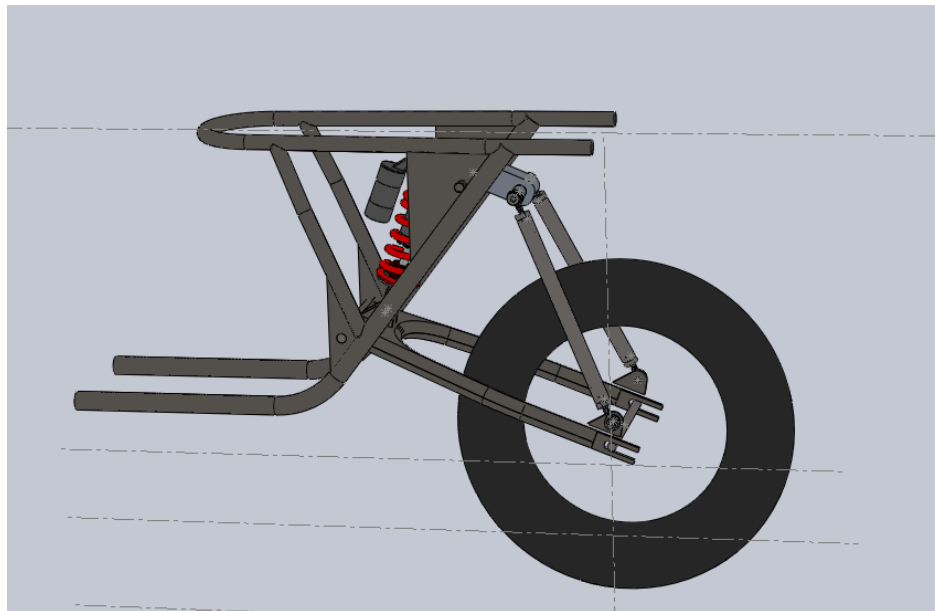

Figure 46 Deformation Analysis



#### 4.6 Initial Prototype and Iteration and Final Analysis

In order to check that our design would fit on the bike with no major concerns, we created an initial prototype constructed out of PVC Pipe and ¼ inch thick plywood. When positioning on the bike in the location prescribed in our SolidWorks model, we ran into one major problem: the chain run. When modelling our design in SolidWorks, we neglected to include the chain run on the bike and in actuality, our tie-rod would interfere with this chain run along the side of the swing-arm. Moving forward, we updated our 3D model in the following ways. First, we spaced out the tie-rods in their attachment on the bolt through the spacer and secondly, we lengthened the tie-rods and connected them to the original suspension system mounting in the rear of the swing arm. These changes can be seen in Figure 47 below.



*Figure 47 Updated SolidWorks Assembly*

This product was designed with the intention of being a consumer-friendly assembly, as such it uses many off the shelf parts as well as many parts from the original bike. This ultimately limited the stress analysis we had to do to the tie-rods, link, and bolt assembly. For the bolt, we calculated Safety Factors at All Critical Sections as seen in the Free Body Diagram in Figure 48 below. In

Table 4 on the next page, 1 dictates the Top of the bolt, and 2 dictates the side of the bolt.

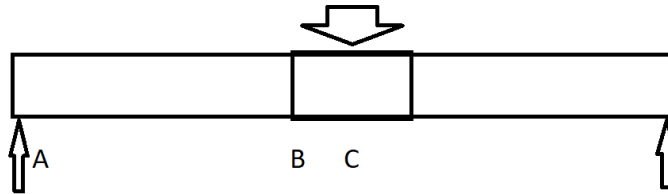

Figure 48 FBD for Bolt

This nomenclature follows for Table 1 as well. The critical sections are at A, B, and C which are the Tie Rod Connection, the Edge of the linkage, and the center of the linkage respectively. The equations for safety factor due to bending is listed below.

$$N_{Bending} = \frac{Sut}{Von\ Mises}$$

The equation for the maximum allowable force for the tie rods is listed below. To find the safety factor due to buckling we utilized the equation for Euler Columns below.

$$Buckling\ Force = n\pi^2 EI / L^2$$

For the welding tabs, we assumed that the system would be installed professionally and thus, used an equation for full penetration of the weld. The equation we used to determine the safety factors for our welding tabs are as follows:

$$SF = \frac{Sut}{\sigma}$$

$$\text{where } \sigma = \frac{P}{hl}.$$

In this equation,  $P$  is the force placed on the weld,  $h$  is the thickness of the weld, and  $l$  is the length of the weld For the Shock Connector the Safety Factor was 37.1 and for the Pivot Connector the Safety Factor was 74.2. These were conservative safety factors that we acquired and was important for our design due to welding variability

Lastly, we knew the maximum load at the bolt holes in the link were 730lbs. We used these values to select appropriate bearings for these locations. The sleeve bearings that we selected were rated at 2150 lbs which gave us a safety factor that was allowable for our design.

Table 4 depicts our full Safety Factor Analysis.

*Table 4 Table of Safety Factors*

<b>Location</b>	<b>Safety Factor</b>
NA1	NA
NA2	50.9
NB1	15.2
NB2	50.9
NC1	8.8
NC2	NA
Buckling	17.9
Shock Connector	37.1
Pivot Connector	74.2
Radial Sleeve Bearing	2.94

## 4.7 Prototype Design

After we initially prototyped our design and made the necessary changes to ensure that it would fit properly on the bike without interference, we updated the SolidWorks model to show our finalized design. From the updated SolidWorks model, we were ready to begin creating Computer Aided Machining files to allow us to manufacture the necessary parts to assemble our design. In addition, these manufactured parts, we utilized off-the-shelf components whenever possible. The off-the-shelf pieces include the various fasteners, washers, spacers, shock assembly, and ball rod ends.

After sourcing all of the possible off-the-shelf components, we had a list of parts that we needed to manufacture: the rocker link, two tie rod links, one pivot rod, four tie rod end inserts, and four weld-on mounting tabs. We then had to select a material to manufacture each of these from. For the rocker link, we chose 6061 aluminum for its light-weight, relative high-strength, and corrosion resistance. For the tie rod links and inserts we chose 304 stainless steel. Steel was desirable for this application due to the high loading that these rods would be subjected to as well as their long length. We required a material with high strength and preferably a shoulder in its strength curve as this was the most likely component to fail. We decided on 304 stainless steel rather than carbon steel for its appealing surface appearance and corrosion resistance. The material selected for the weld on tabs was 1023 low carbon steel, the same material the CB750 frame and swingarm was constructed from. This was to ensure we had a strong weld between the tabs and motorcycle, as well as to simplify installation.

Once the material was selected for each part, we sourced the material and began the manufacturing process. The first step was to create Computer Aided Machining (CAM) files for all of the parts we planned to fabricate using Computer Numerical Control (CNC) Machining. These parts included the rocker link and the tie rod inserts. The program we used to create the CAM files for these parts was DP Technology's Esprit. The 5/8in-18 threaded tie rod insert can be seen in Figure 49 below, and the 3/8in-24 threaded tie rod insert can be seen in Figure 50.

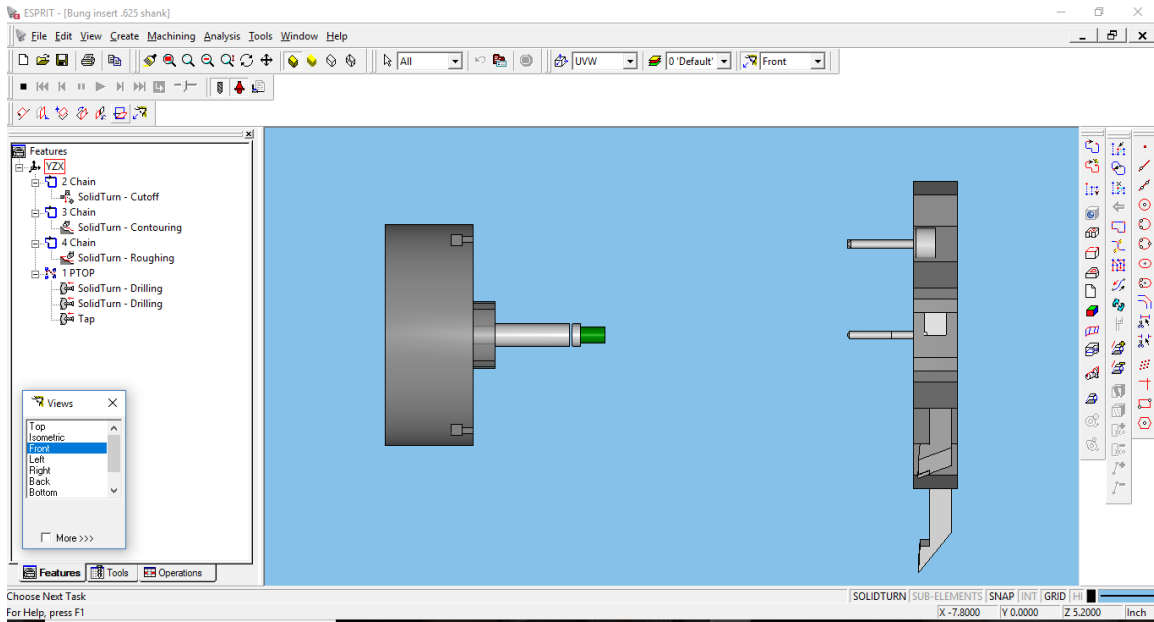

Figure 49 Image of .625 insert after facing, contouring, drilling, and cutoff operations

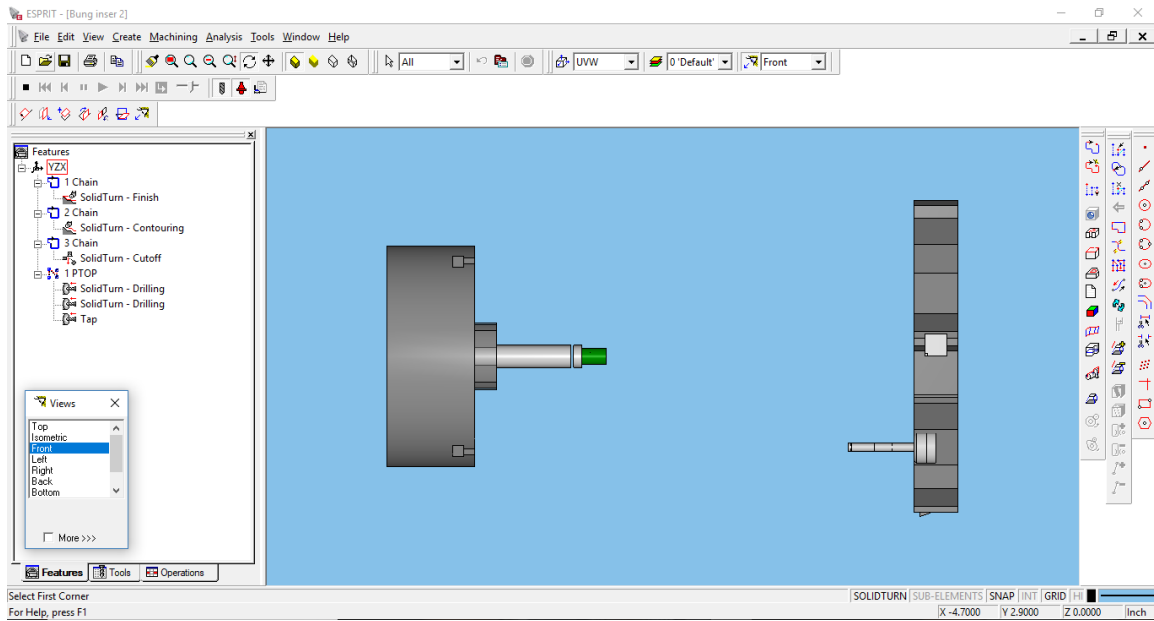

Figure 50 Image of .375 insert after facing, contouring, drilling, and cutoff operations

We manufactured the four tie rod inserts on a Haas Automation Inc. ST-10 CNC Lathe. These parts each required six operations: facing the end flat, contouring the profile, drilling a pilot hole, drilling a hole for the inside diameter of the threads, tapping the threads, and cutting of the part.

The other CAM files we created was for the rocker link. This part required three different files as we had to rotate and mount the part inside the machine three different times in order to achieve the necessary geometry. The first operation can be seen in Figure 51 below. This included the facing of the link, contouring the profile, drilling three through holes, and then pocketing two holes.

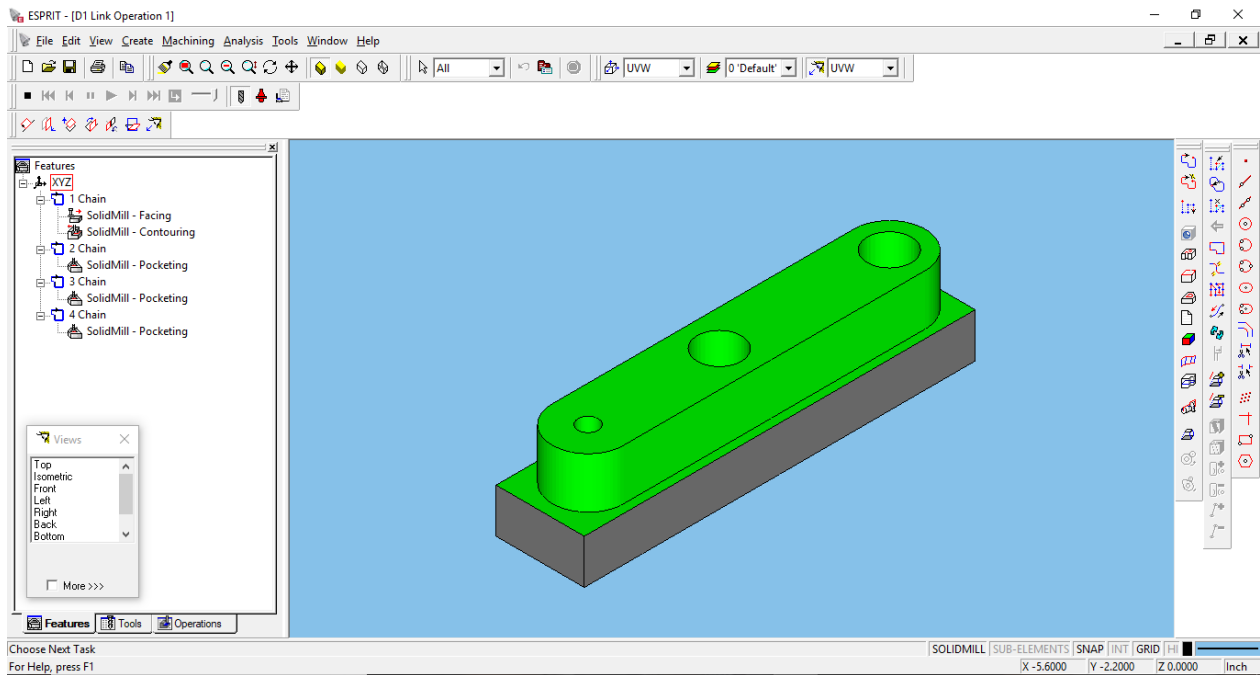

Figure 51 Image of link after facing, contouring, and pocketing operations on one side of part

The next file worked on the link rotated 180 degrees about the x-axis. These operations can be seen in Figure 52 below. The operations included in this file include facing the bottom of the link, and finishing the contouring of the profile.

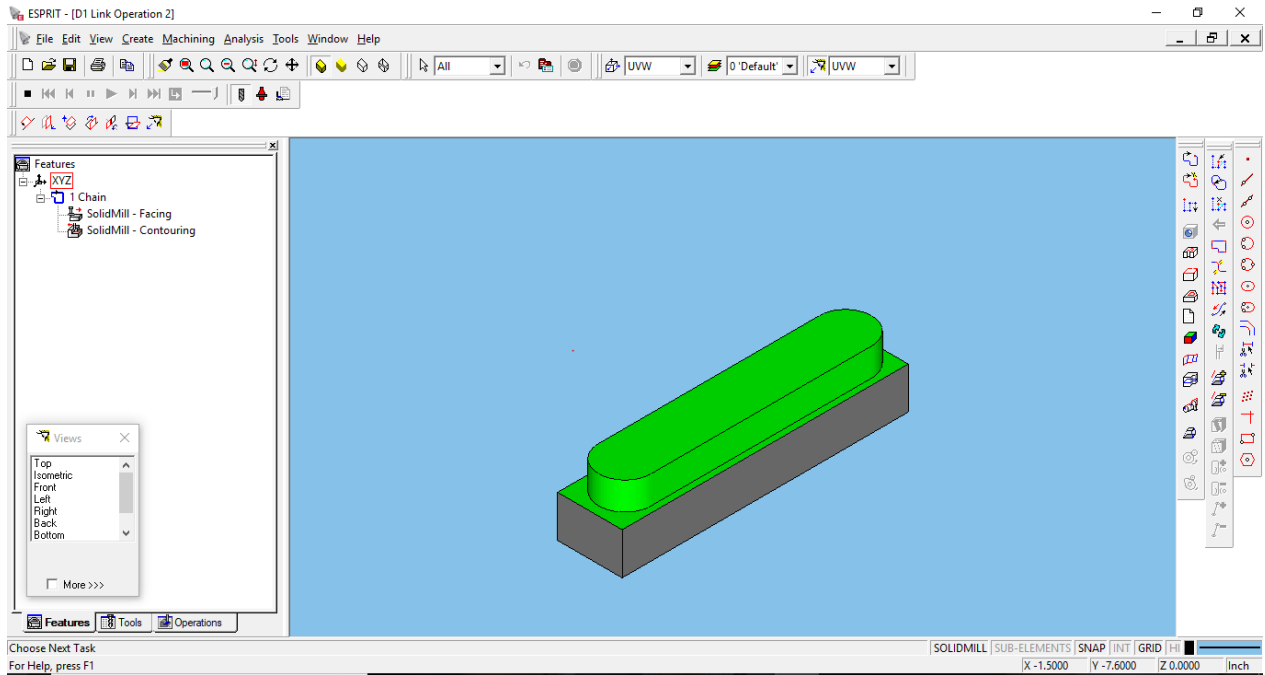

Figure 52 Image of link after facing and contouring operations on opposite side of part

The next file worked on the link rotated 90 degrees about the x-axis. These operations can be seen in Figure 53 below. The operation included in this file was the pocketing of the hole where the shock would mount.

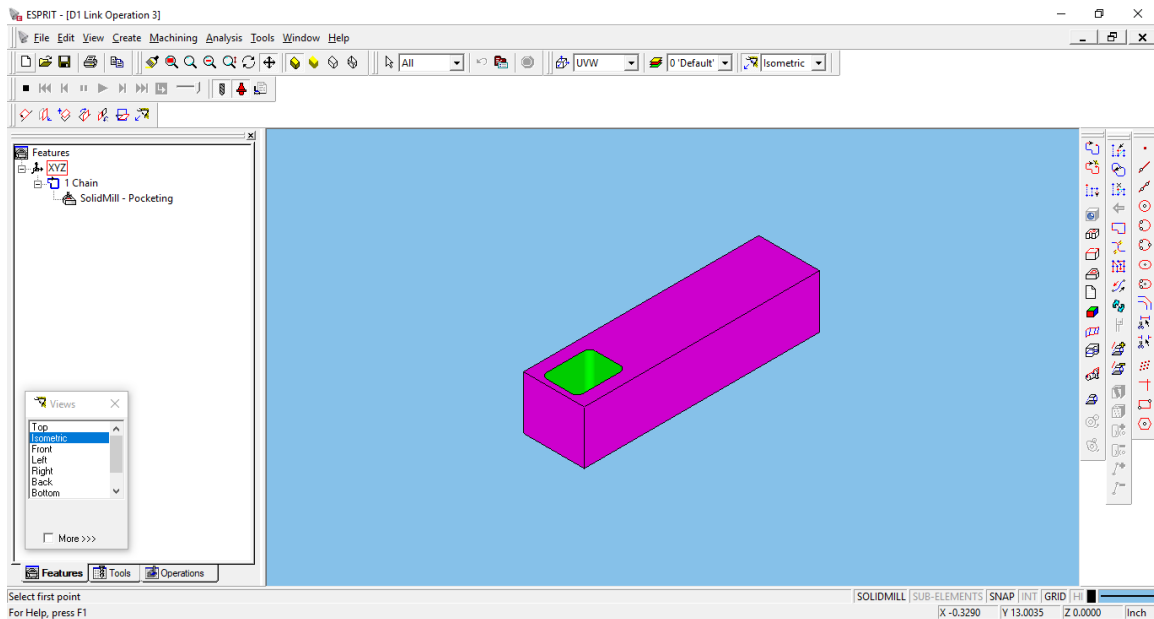

Figure 53 Image of link after pocketing operation on part rotated 270 degrees from original position

Once completing these CAM files and successfully simulating all of the operations, we manufactured the rocker link on a Haas Automation Inc CNC Minimill. The link was manufactured out of a 7.825 x 2.25 x 2 in block of 6061 aluminum.

We then manufactured our weld-on mounting tabs using non-interlock machinery in Washburn Shops. This involved tracing the geometry of the four tabs onto a .25 in sheet of 1023 steel. The parts we then cut on a vertical band saw and hand finished on a grinder to smooth the profiles and remove any burrs. Then utilized the manual drill press to tap, peck, and drill a hole through the tabs.

The final part that we manufactured was bodies of the two tie rods. These were created out of 304 stainless steel tubing with a one-inch outer diameter and a .76-inch inside diameter. These were cut to length using a horizontal band saw, then finished by facing and deburring them on a manual lathe

The next step in our manufacturing process was assemble the tie rods. This required us to chamfer both ends of the two tie rods, as well as the mating faces on all four inserts. The inserts



were then placed into the tie rods and welded in place. The ball rod ends were then screwed into the inserts and the tie rods were complete. These can be seen in Figure 54 below.



*Figure 54 Tie Rods with Ball Rod Ends*

Once the tie rods were completed, we had to assemble the bearings into two of the mounting tabs and the rocker link. To accomplish this, we used a mechanical press. The completed link with bearings can be seen in Figure 55 below.

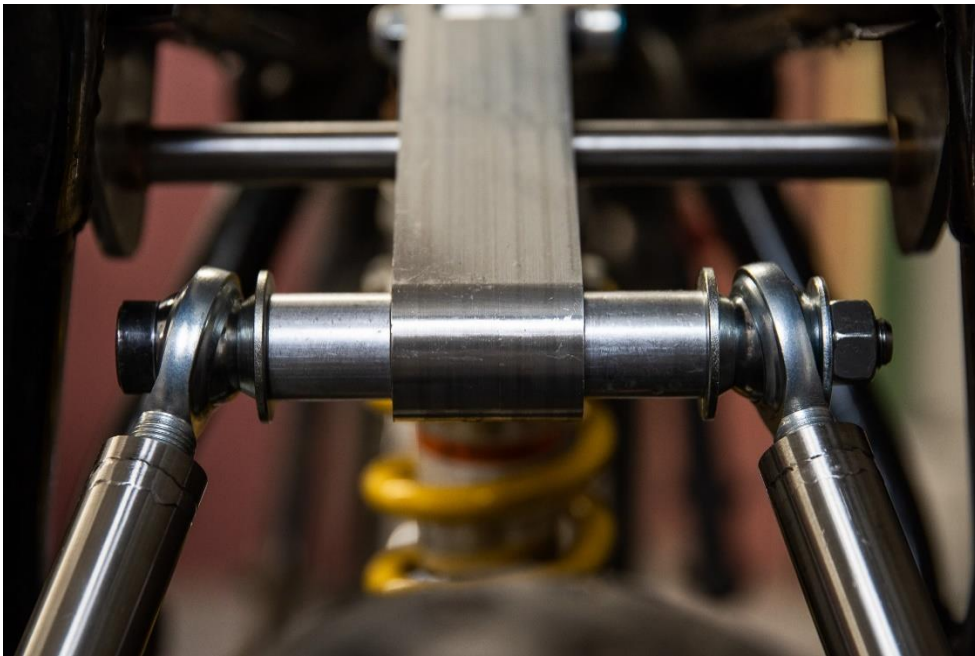

*Figure 55 Side View of Rocker Link*

With all of the parts manufacture and sub-assemblies completed, we were ready to install the system onto the 1981 CB750k. We welded the two suspension mounting tabs onto the swingarm, measuring the proper location based on our 3D model. The pivot mounting tables were then welded to the triangulated section of the rear frame. Once these tabs were installed, we assembled the remaining parts of our assembly onto our bike. The completed system can on the following pages in Figure 56, Figure 57, Figure 58, and Figure 59



*Figure 56 Side Profile of Suspension System on Bike*



*Figure 57 Suspension Rocker Link on Pivot from Rear*



*Figure 58 Suspension System from Rear*



*Figure 59 Detail View of Shock, Link, and Pivot*

## 5. Conclusions

### 5.1 Project Specifications

Overall, we feel as though our design achieved a proof of concept for our project. Although our final system was not quantitatively tested post fabrication and designed for mass manufacturability, it did prove that designing a system that could theoretically be easy to purchase and install to modernize older Honda CB motorcycle suspension is possible. In order to fully meet our project specifications and before being able to release a product that commercially available, we would suggest several areas of improvement.

### 5.2 Future Recommendations

Among recommendations to improve, we would press for easier manufacturability of our unique parts. Particularly, we would optimize the main linkage and the rod ends of our tie rods. As far the main linkage goes, in order to save material cost and machining time, we recommend that a future iteration more closely align with the industry standard of a plate-based linkage. This link would essentially, be two thin plates, approximately  $\frac{1}{4}$  inch in thickness, shaped the same as the side profile of our linkage. These links would be spaced via spacers throughout the link. The result would be a much lighter product that would require much less raw material, as instead of requiring a large block of 6061 Aluminum Alloy, only  $\frac{1}{4}$  inch thin plates would be necessary. It would also cut down on machining time because it could be cut via Waterjet CNC in one operation as opposed to 3 individual operations on the CNC Mill.

Next, we would check for optimum compatibility across all Honda CB models. To do this, we would recommend acquiring as many Honda CB models from various years as possible to take appropriate measurements. Among these measurements are swingarm length, swingarm width, and frame width. Next, it would be important to check to see if the current setup would be able to be mounted properly on these various bike's while maintaining the overall technical performance and progressiveness. If the positioning of locations becomes to different and alters the performance of the system, creating multiple kits with as many cross over parts as possible, would be an ideal situation to allowing for more transferability between models while maintaining the progressiveness of the system. Having multiple tie-rod length options or multiple link size options would be one way to do this. All of these different models would need to be analyzed and tested to ensure safety.

Some materials and components in our system could be optimized for a variety of purposes. The main areas of material optimization would occur with our hex nuts, especially the nuts between the tie rod and ball rod end. Most commercially available nuts are zinc plated, however this drastically lowers the aesthetic appeal we want to show in our design and our choice in using Stainless Steel 304 for the tie rods and rod ends. Custom ordering stainless steel nuts for this purpose would maintain the aesthetic integrity of our system and design. Additionally, instead of buying a steel rod, cutting this unit, and threading the rod for a respective nut, purchasing a pre-threaded bolt, while making the raw material cost higher, would make the manufacturing and assembly substantially easier.

After the previous changes, testing the system in a drop test and via an industry standard fatigue mechanism is important to fully validate our design. Testing with a drop test would allow us to experimentally test the progressiveness of the system (wheel and shock displacement over time given an applied force. The force of this system would be the force due to acceleration of the mass of the system. Ideally, this test would be performed with a small lifting device capable of lifting approximately 500 pounds. Once at a height that would provide substantially more force than one would encounter in a standard ride (18-24 inches), the bike would be dropped. There will be a capable slow-motion camera recording the test from a side profile, with a ruler in plane in the same plane as both the shock and tire. During the drop, safety would be a paramount concern and it would be important to ensure the bike does not topple over after dropping. After the data is collected, plotting the wheel travel vs spring compression would allow us to compare the experimental Wheel Rate to the theoretical Wheel Rate we calculated earlier.

After the Drop Test is performed, an experimental fatigue analysis would be important in ensuring the safety of our product throughout its lifetime. Although, after market motorcycle suspension modifications are rarely put tested like this, since our product would be a more universal, commercially available product, it would be important for ensuring safety. Motorcycle manufacturers like Honda, Yamaha and Kawasaki, among others, all physically test their systems with rigs that simulate riding. These tests are performed to simulate 40-50 thousand miles of riding quickly to see if the various components are able to withstand these prolonged forces with an appropriate safety factor. Getting access to one of these testing rigs would be a critical component to receiving more than theoretical data about how long our system would last.

Once taking all of the above recommendations into account, we would be able to file for a patent on our design and begin manufacturing and selling our product commercially as a kit to technically and aesthetically improve Honda CB motorcycle rear suspension.



## 6. References

- "All About Geometry." *Sport Rider*. Web. Sep 29, 2017 <<http://www.sportrider.com/all-about-geometry>>.
- Anti-Squat Geometry*., 2016. Web. Sep 29, 2017.
- Byrnes, Graham. "Motorcycle and Chassis Specialists." *ProMechaWeb*.
- Carlson, J. D. (2000). Implementation of Semi-Active Control Using Magneto-Rheological Fluids. *IFAC Proceedings Volumes*, 33(26), 905-910. doi:10.1016/s1474-6670(17)39260-1
- Classic British Motorcycle. "Vincent Motorcycles." *Classic-British-Motorcycles.com*. 2017. Web. Sep 28, 2017 <<http://www.classic-british-motorcycles.com/vincent-motorcycles.html>>.
- Cullinan, J. R. (1976). *U.S. Patent No. 3,966,006*. Washington, DC: U.S. Patent and Trademark Office.
- Cycle World. "1969 Honda CB750 Road Test." *Cycle World* 1969Print.
- Dean, Jeffrey. "R51-3 Left." *Wikimedia Commons*. 2011. Web.
- Foale, Tony. *Motorcycle Handling and Chassis Design* &nbsp;. second ed. Spain: Tony Foale Designs, 2006. Print.
- Frendo, F., Sisi, A., Guiggiani, M., & Piazza, S. D. (2006). Analysis of motorcycle models for the evaluation of the handling performances. *Vehicle System Dynamics*,44, 181-191. doi:10.1080/00423110600869974
- Halliday, J. (2003, April 14). ADVANCING AGE OF MOTORCYCLE BUYERS 'AN INDUSTRY CONCERN'. Retrieved September 11, 2017, from <http://adage.com/article/news/advancing-age-motorcycle-buyers-industry-concern/37285/>
- Honda. "The Dream Cb750 Four." *Honda Worldwide*. 2011. Web.
- Jarman, R. E., Shreve, R. L., & Smith, F. W. (1975). *U.S. Patent No. 3,917,313*. Washington, DC: U.S. Patent and Trademark Office.
- Lam, A. H. F., & Liao, W. H. (2003). Semi-active control of automotive suspension systems with magneto-rheological dampers. *International Journal of Vehicle Design*, 33(1-3), 50-75.
- Laporte, J. (n.d.). Topic: Motorcycle Industry in the U.S. Retrieved September 11, 2017, from <https://www.statista.com/topics/1305/motorcycles-in-the-us/>

- (No. SR-014). US Department of Transportation, Research and Innovative Technology Administration, Bureau of Transportation Statistics.
- Lindeman, Mark. "Understanding a Motorcycle's Rake and Trail." *Cycle World*. 2015. Web. Sep 28, 2017 <<http://www.cycleworld.com/2015/05/22/cycle-world-tips-and-tricks-understanding-motorcycle-rake-and-trail>>.
- Lindemann, M. (2014, January 15). What You Need To Know About Suspension. Retrieved August 28, 2017, from <http://www.cycleworld.com/2014/01/15/what-you-need-to-know-about-suspension>
- Macdonald, J. M., & Macdonald, C. J. (1976). *U.S. Patent No. 3,948,543*. Washington, DC: U.S. Patent and Trademark Office.
- Motorcycle Classics. "The Featherbed Norton Manx." *Motorcycle Classics*. 2011. Web. Sep 28, 2017 <<http://www.motorcycleclassics.com/wheels-on-reels/featherbed-norton-manx>>.
- Motorcycle Mechanics Institute. *The Complete Guide to Motorcycle Mechanics.*, 1984. Print.
- Pacejka, H. B. (2012). Motorcycle Dynamics. *Tire and Vehicle Dynamics*, 505-565.  
doi:10.1016/b978-0-08-097016-5.00011-5
- Parigian, G. M. (2003). *U.S. Patent No. 6,527,289*. Washington, DC: U.S. Patent and Trademark Office.
- Parker, J. G. (2006). *U.S. Patent No. 7,121,570*. Washington, DC: U.S. Patent and Trademark Office.
- Red, Head10. "Vintage Motorcycle." *Flickr*. 2010. Web.
- Shock Preload Adjusters. (n.d.). Retrieved August 28, 2017, from <http://www.progressivesuspension.com/c/tech-info-shock-preload-adjusters>
- Shock Sag Adjustment. (n.d.). Retrieved August 28, 2017, from <http://www.progressivesuspension.com/c/tech-info-shock-sag-adjustment>
- Spelta, C., Savaresi, S. M., & Fabbri, L. (2010). Experimental analysis of a motorcycle semi-active rear suspension. *Control Engineering Practice*, 18(11), 1239-1250.
- Springs. (n.d.). Retrieved August 28, 2017, from <http://www.progressivesuspension.com/c/tech-info-springs>
- The Basics of Motorcycle Suspension. (n.d.). Retrieved August 28, 2017, from <http://www.progressivesuspension.com/c/the-basics-of-motorcycle-suspension>

V-Twin Manufacturing. "V-Twin Manufacturing Chrome Swingarm for Sportster." *J&P Cycles*. Web. Sep 28, 2017.

Wilson, Hugo (1995). *The Encyclopedia of the Motorcycle*. Dorling-Kindersley. ISBN 0-7513-0206-6.