

**MOTORI AD INGRANAGGI
GEAR MOTORS**Pag.
Page

CARATTERISTICHE FEATURES		C-2
CONDIZIONI D'IMPIEGO USE CONDITIONS		C-2
INFORMAZIONI TECNICHE TECHNICAL INFORMATION		C-3
GAMMA DI PRODOTTO PRODUCT RANGE		C-4
MOTORI GRUPPO MOTORS GROUP	2	C-6
MOTORI GRUPPO MOTORS GROUP	3	C-16

CARATTERISTICHE

Motori ad ingranaggi esterni dal gruppo 2 al gruppo 3 suddivisi in 17 cilindrate da 4 a 61,1cc, fino a 270 bar di pressione massima di esercizio e velocità massima fino a 4000 giri/min., con bilanciamento idrostatico a ripresa del gioco assiale.

Disponibili in versione unidirezionale o reversibile (utilizzabili anche in serie).

Ogni motore può essere assemblato con totale intercambiabilità sia con flange standard (europea tedesca, SAE) sia con quelle speciali e con alberi conici, cilindrici e scanalati. E' possibile inoltre montare coperchi per due velocità e con valvola limitatrice di pressione.

I motori sono disponibili nelle esecuzioni unidirezionale e reversibile

FEATURES

Motors with external gears from group 2 to group 3, divided into 17 displacements from 4 to 61,1cc, up to 270 bar of max working pressure and maximum speed up to 4000 rpm, with hydrostatic balance to reduce the axial slack.

Gear motors are available in unidirectional and reversible versions (reversible motors can be used same in serie circuit).

Each motor can be assembled with standard flanges (European, German or SAE) or with special ones (ZF, Perkins and Renault), with conic, cylindrical or splined shaft. Furthermore it is possible to assemble covers with two speed function and with pressure relief valve.

The motors are available in unidirectional D - S and reversible R version.

Motore unidirezionale (D-S)
Unidirectional motor (D-S)

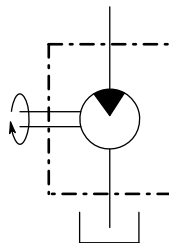

Motore reversibile (R)
Reversible motor (R)

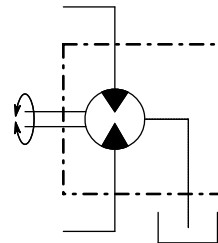

CONDIZIONI D'IMPIEGO

- Temperatura d'impiego 20°C ÷ 65°C
- Temperatura limite -15 °C ÷ 80°C
- Pressione ammessa in aspirazione min. 0.7 max. 3 bar (assoluti)
- Viscosità raccomandata 15 ÷ 92 mm² /s
- Viscosità limite d'avviamento 3000 mm² /s
- Filtraggio 26/23 ISO DIS 4406 fino a 150 bar
23/20 ISO DIS 4406 per pressioni superiori

USE CONDITIONS

- Temperature 20°C ÷ 65°C
- Max. temperature - 15 °C ÷ 80°C
- Suction allowed pressure min. 0.7 max. 3 bar (absolute)
- Recommended viscosity 15 ÷ 92 mm² /s
- Start max. viscosity 3000 mm² /s
- Filtering 26/23 150 ISO DIS 4406 until 2175 psi
23/20 ISO DIS 4406 for higher pressure

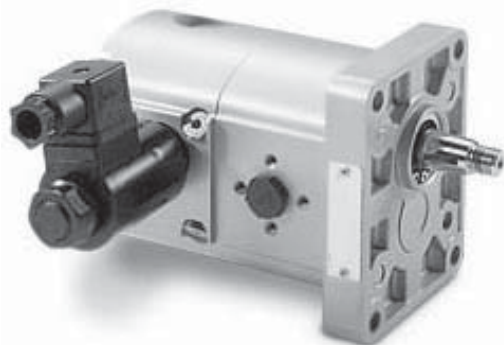

INFORMAZIONI TECNICHE

Definizione delle pressioni

I motori possono essere sottoposti alle pressioni P1, P2 indicate nelle tabelle delle prestazioni. Il grafico seguente ne illustra le definizioni e l'applicabilità rispettando i limiti delle velocità di rotazione riportati.

TECHNICAL INFORMATION

Definition of pressures

The motors can be subjected to the pressures P1, P2 indicated in the performance tables. The following diagram illustrates the definitions and applicability of these, compared to the rotation speed limits included.

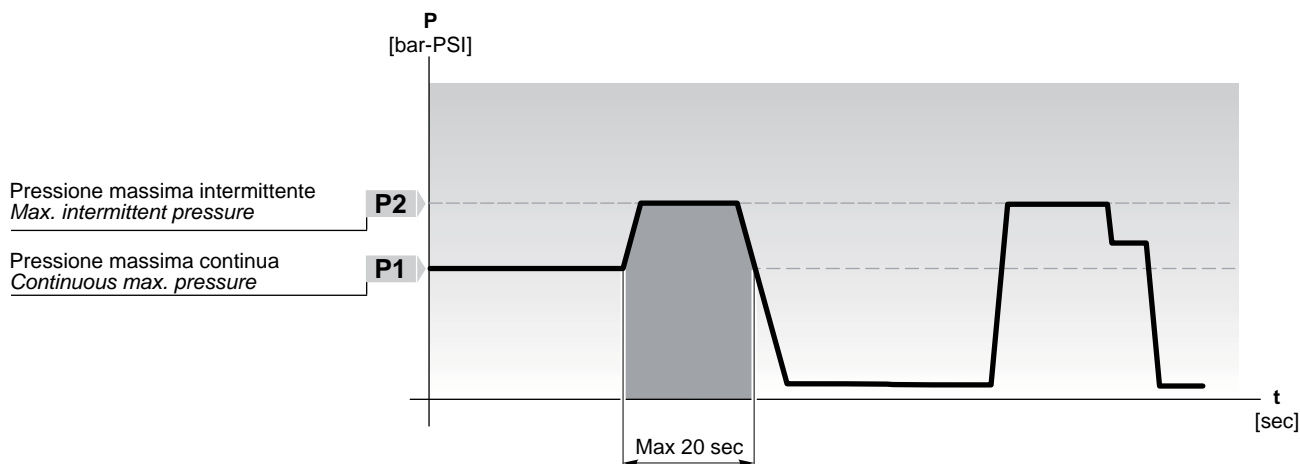

Misure idrauliche Hydraulic measures

Q	Portata Flow	[l/min - Gal/min]
M	Coppia Torque	[Nm - lbf.in]
P	Potenza Power	[kW - HP]
V	Cilindrata Displacement	[cm ³ /rev - in ³ /rev]
N	Velocità Speed	[min ⁻¹ - rpm]
Δp	Pressione Pressure	[bar - PSI]
η_v	Rendimento volumetrico Volumetric efficiency	
η_m	Rendimento meccanico Mechanical efficiency	
η_t	Rendimento totale Overall efficiency	

Formule utili Useful formulas

$$Q = \frac{V [\text{cm}^3/\text{rev}] \times n \times 10^3}{\eta_v} \quad \text{l/min}$$

$$M = \frac{\Delta p [\text{bar}] \times V [\text{cm}^3/\text{rev}] \times \eta_m}{62.83} \quad \text{Nm}$$

$$P = \frac{\Delta p [\text{bar}] \times V [\text{cm}^3/\text{rev}] \times n \times \eta_t}{600 \times 1000} \quad \text{kW}$$

Fattore di conversione Conversion factors

1 l/min = 0.2641 US Gal/min
1 Nm = 8.851 in-lbs
1 Nm = 0.7375 ft-lbs
1 N = 0.2248 lbs
1 kW = 1.34 HP
1 cm ³ /giro = 0.061 in ³ /rev
1 bar = 14.5 PSI
1 mm = 0.0394 in
1 kg = 2.205 lbs

GAMMA DI PRODOTTO

PRODUCT RANGE

MOTORI GRUPPO
MOTORS GROUP

2

D = Rotazione destra / Clockwise rotation
S = Rotazione sinistra / Anticlockwise rotation
R = Reversibile / Reversible

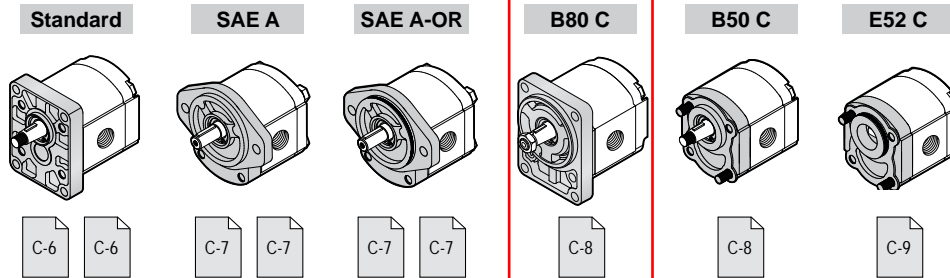

Grandezza Size	Cilindrata Displacement [cm³/rev] (in³/rev)	Pressione max. d'esercizio Max. working pressure				Velocità max. Max. speed [g/min] (rpm)	Portata max. Max. flow [l/min] (Gal/min)	Velocità min. Min. speed [g/min] (rpm)	Portata min. Min. flow [l/min] (Gal/min)
		P1 [bar] / (PSI)		P2 [bar] / (PSI)					
		S - D	R	S - D	R				
2SM_4	4 (0.24)	230 (3335)	230 (3335)	270 (3915)	230 (3335)	4000	16 (4.23)	500	1.9 (0.50)
2SM_6	6 (0.37)	230 (3335)	230 (3335)	270 (3915)	230 (3335)	4000	24 (6.34)	500	2.85 (0.75)
2SM_8	8.5 (0.52)	230 (3335)	230 (3335)	270 (3915)	230 (3335)	3500	29.7 (7.85)	500	4.03 (1.06)
2SM_11	11 (0.67)	230 (3335)	230 (3335)	270 (3915)	230 (3335)	3500	38.5 (10.17)	500	5.22 (1.38)
2SM_14	14 (0.85)	230 (3335)	230 (3335)	270 (3915)	230 (3335)	3500	49 (12.95)	500	6.65 (1.76)
2SM_16	16.5 (1.01)	230 (3335)	200 (2900)	240 (3480)	200 (2900)	3500	57.7 (15.24)	500	7.83 (2.07)
2SM_19	19.5 (1.19)	210 (3045)	185 (2683)	220 (3190)	185 (2683)	3300	64.3 (16.99)	500	9.26 (2.45)
2SM_22	22.5 (1.37)	190 (2755)	170 (2465)	200 (2900)	170 (2465)	2800	63 (16.64)	500	10.68 (2.82)
2SM_26	26 (1.59)	170 (2465)	150 (2175)	180 (2610)	155 (2248)	2500	65 (17.17)	500	12.35 (3.26)

* (Valori rilevati in fase di collaudo a 1500 giri/min / Value collected during the testing at 1500 rpm)

Esempio di ordinazione in codice / Example of ordering code

2SM	A	14	D	(K)	-	10	G	(VT)
------------	----------	-----------	----------	------------	----------	-----------	----------	-------------

2SM	Tipo motore / Motor type	vedi tabella / see table
A	Flangia e coperchio / Flange and cover	A = Alluminio / Aluminium G = Ghisa / Cast iron
14	Cilindrata / Displacement	vedi tabella / see table
D	Rotazione destra / Clockwise rotation	D = Rotazione destra / Clockwise rotation S = Rotazione sinistra / Anticlockwise rotation R = Reversibile / Reversible
— ⁽¹⁾	Tipo flangia / Flange type	
(K)	Anello di rinforzo per alta pressione sullo scarico - max. 30 bar Seal for high pressure on the tank return line - max. 30 bar	(a richiesta / optional)
—		
10	Tipo albero / Shaft type	10 - 11 - 12 - 13 - 14 - 15 - 16 - 17
G	Tipo connessioni / Connections type	G - N - T - U - F - M - W
(VT)	Opzioni / Optional	(VT) Guarnizione in Viton (a richiesta) Viton seals (optional) VLP-I (N)⁽²⁾ - VLP-E (N)⁽²⁾ Valvola limitatrice di pressione (pag. C-11) Pressure relief valve (page C-11)

⁽¹⁾ Non è necessario indicare la flangia STANDARD / It is not necessary indicate STANDARD flange

⁽²⁾ Solo per motori unidirezionali / Only for unidirectional motors

GAMMA DI PRODOTTO

PRODUCT RANGE

**MOTORI GRUPPO
MOTORS GROUP**

3

D = Rotazione destra / *Clockwise rotation*
S = Rotazione sinistra / *Anticlockwise rotation*
R = Reversibile / *Reversible*

Standard

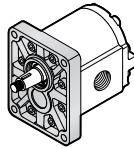

C-14 C-14

SAE B

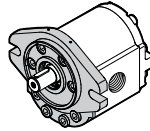

C-15 C-16

SAE B-OR

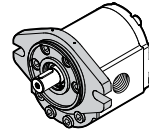

C-15 C-15

Grandezza Size	Cilindrata Displacement [cm³/rev] (in³/rev)	Pressione max. d'esercizio Max. working pressure				Velocità max. Max. speed [g/min] (rpm)	Portata max. Max. flow [lt/min] (Gal/min)	Velocità min. Min. speed [g/min] (rpm)	Portata min. Min. flow [lt/min] (Gal/min)
		P1 [bar] / (PSI)		P2 [bar] / (PSI)					
		S - D	R	S - D	R				
3SM_19	19 (1.16)	250 (3625)	215 (3118)	270 (3915)	220 (3190)	3500	66.5 (17.57)	700	12.64 (3.34)
3SM_22	22.3 (1.36)	240 (3480)	205 (2973)	260 (3770)	220 (3190)	3500	78 (20.61)	700	14.83 (3.92)
3SM_29	29.3 (1.79)	220 (3190)	190 (2755)	240 (3480)	205 (2973)	3300	96.7 (25.55)	700	19.48 (5.15)
3SM_33	32.9 (2.01)	220 (3190)	190 (2755)	240 (3480)	205 (2973)	3300	108.6 (28.69)	700	21.88 (5.78)
3SM_36	36.4 (2.22)	210 (3045)	180 (2610)	230 (3335)	205 (2973)	3300	120.1 (31.73)	700	24.21 (6.40)
3SM_44	43.5 (2.65)	200 (2900)	170 (2465)	220 (3190)	185 (2683)	3000	130.5 (34.48)	700	28.93 (7.64)
3SM_52	51.7 (3.15)	200 (2900)	170 (2465)	220 (3190)	180 (2610)	3000	155.1 (40.98)	700	34.38 (9.08)
3SM_62	61.1 (3.73)	180 (2610)	160 (2320)	190 (2755)	160 (2320)	2500	152.7 (40.34)	700	40.63 (10.73)

* (Valori rilevati in fase di collaudo a 1500 giri/min / Value collected during the testing at 1500 rpm)

Esempio di ordinazione in codice / Example of ordering code

3SM A 22 D (K) - 10 G (VT)

3SM	Tipo motore / <i>Motor type</i>	vedi tabella / <i>see table</i>
A	Flangia e coperchio / <i>Flange and cover</i>	A = Alluminio / <i>Aluminium</i> G = Ghisa / <i>Cast iron</i>
14	Cilindrata / <i>Displacement</i>	vedi tabella / <i>see table</i>
D	Rotazione destra / <i>Clockwise rotation</i>	D = Rotazione destra / <i>Clockwise rotation</i> S = Rotazione sinistra / <i>Anticlockwise rotation</i> R = Reversibile / <i>Reversible</i>
— ⁽¹⁾	Tipo flangia / <i>Flange type</i>	
(K)	Anello di rinforzo per alta pressione sullo scarico - max. 30 bar <i>Seal for high pressure on the tank return line - max. 30 bar</i>	(a richiesta / <i>optional</i>)
—		
10	Tipo albero / <i>Shaft type</i>	10 - 13 - 14
G	Tipo connessioni / <i>Connections type</i>	G - N - W - F - T
(VT)	Opzioni / <i>Optional</i>	(VT) Guarnizione in Viton (a richiesta) <i>Viton seals (optional)</i> VLP-I (N) ⁽²⁾ Valvola limitatrice di pressione (pag. C-18) <i>Pressure relief valve (page C-18)</i>

⁽¹⁾ Non è necessario indicare la flangia STANDARD / *It is not necessary indicate STANDARD flange*

⁽²⁾ Solo per motori unidirezionali / *Only for unidirectional motors*

Dimensioni / Dimensions

Flangia e coperchio in Alluminio / Flange and cover in Aluminium

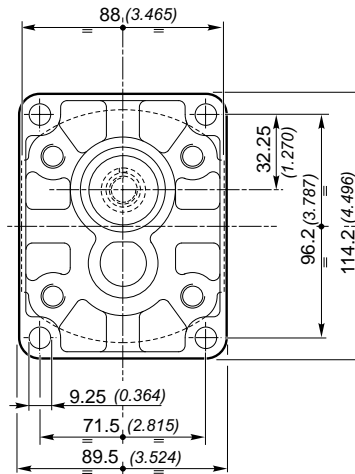
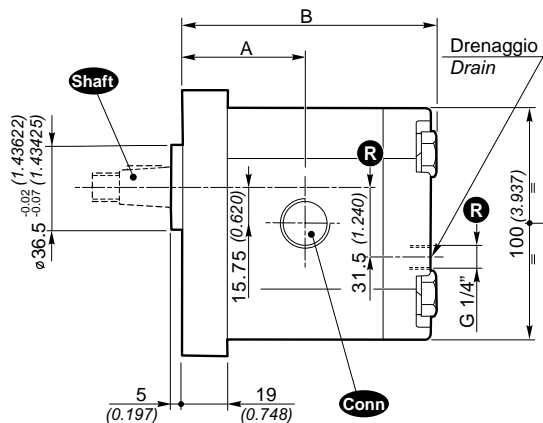

R Solo per motori reversibili
Only for reversible motors

Flangia e coperchio in Ghisa / Flange and cover in Cast iron

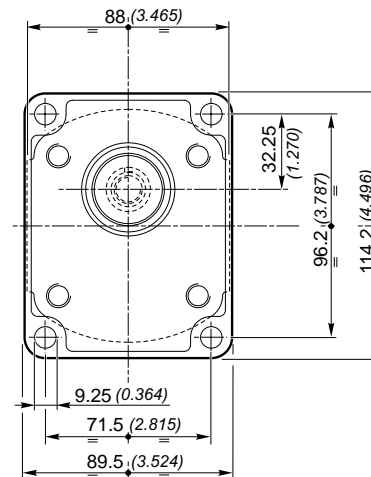
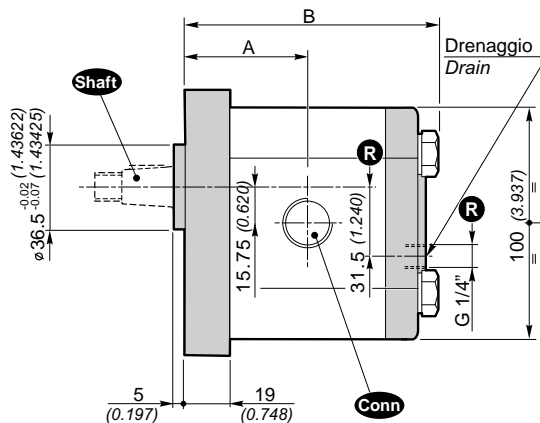

STND (Alluminio / Aluminium)

STND (Ghisa / Cast iron)

Grandezza Size	Cilindrata Displacement	Dimensioni Dimensions		Massa Mass	Shaft	Conn	Dimensioni Dimensions		Massa Mass	Shaft	Conn
		A	B				A	B			
	[cm ³ /rev] [in ³ /rev]	[mm] [inch]	[mm] [inch]	[Kg] [lbs]			[mm] [inch]	[mm] [inch]	[Kg] [lbs]		
2SM_4	4 (0.24)	44.4 (1.748)	93 (3.661)	2.30 (5.1)	10 11 12 13 14 15 16	G N T M U W F	44.4 (1.748)	93 (3.661)	3.40 (7.5)	10 11 12 13 14 15 16	G N T M U W F
2SM_6	6 (0.37)	46 (1.811)	96.3 (3.791)	2.45 (5.4)			46 (1.811)	96.3 (3.791)	3.60 (7.8)		
2SM_8	8.5 (0.52)	48.1 (1.894)	100.5 (3.957)	2.60 (5.7)			48.1 (1.894)	100.5 (3.957)	3.70 (8.2)		
2SM_11	11 (0.67)	50.2 (1.976)	104.6 (4.118)	2.70 (6.0)			50.2 (1.976)	104.6 (4.118)	3.80 (8.4)		
2SM_14	14 (0.85)	52.7 (2.075)	109.6 (4.315)	2.80 (6.2)			52.7 (2.075)	109.6 (4.315)	3.90 (8.6)		
2SM_16	16.5 (1.01)	54.8 (2.157)	113.8 (4.480)	2.95 (6.5)			54.8 (2.157)	113.8 (4.480)	4.05 (8.9)		
2SM_19	19.5 (1.19)	57.3 (2.256)	118.8 (4.677)	3.10 (6.8)			57.3 (2.256)	118.8 (4.677)	4.20 (9.3)		
2SM_22	22.5 (1.37)	59.8 (2.354)	123.8 (4.874)	3.25 (7.2)			59.8 (2.354)	123.8 (4.874)	4.35 (9.6)		
2SM_26	26 (1.59)	62.7 (2.469)	129.6 (5.102)	3.40 (7.5)			62.7 (2.469)	129.6 (5.102)	4.50 (9.9)		

Dimensioni / Dimensions

SAE A-OR

SAE A

Flangia e coperchio in Alluminio / Flange and cover in Aluminium

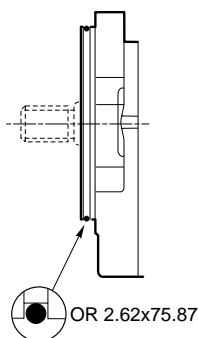

R Solo per motori reversibili
Only for reversible motors

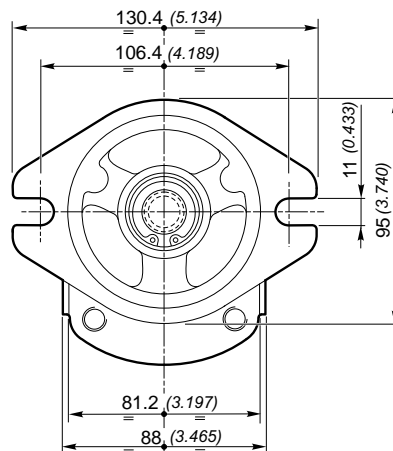
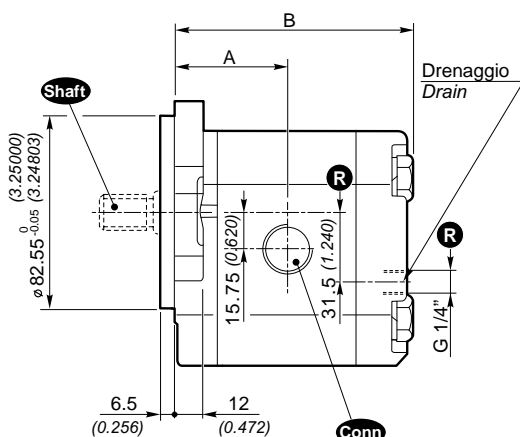

SAE A-OR

SAE A

Flangia e coperchio in Ghisa / Flange and cover in Caston iron

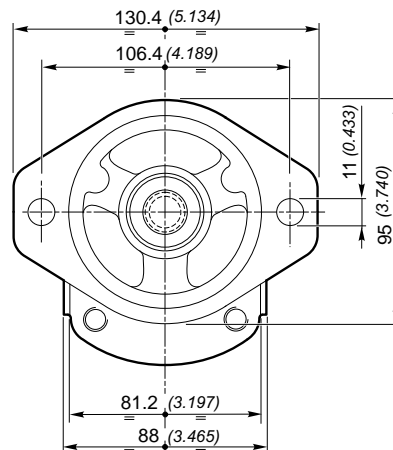
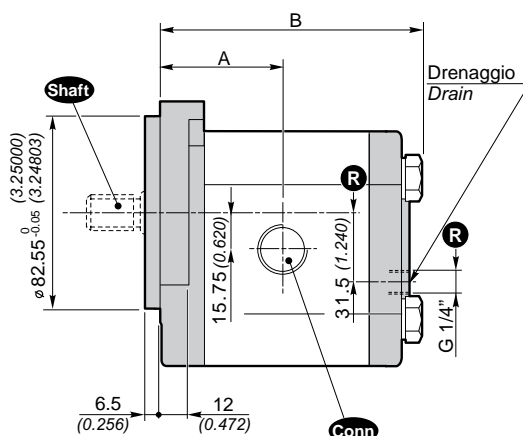
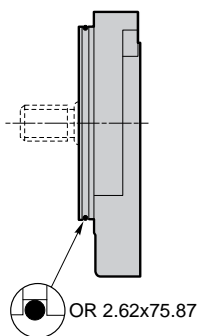

SAE A, SAE A-OR (All. / Aluminium)

SAE A, SAE A-OR (Ghisa / Cast iron)

Grandezza Size	Cilindrata Displacement [cm ³ /rev] [in ³ /rev]	Dimensioni Dimensions		Massa Mass [Kg] [lbs]	Shaft	Conn	Dimensioni Dimensions		Massa Mass [Kg] [lbs]	Shaft	Conn
		A [mm] [inch]	B [mm] [inch]				A [mm] [inch]	B [mm] [inch]			
2SM_4	4 (0.24)	44.4 (1.748)	93 (3.661)	2.30 (5.1)	10 11 12 13 14 15 16	G N T M U W F	44.4 (1.748)	93 (3.661)	3.40 (7.5)	10 11 12 13 14 15 16	G N T M U W F
2SM_6	6 (0.37)	46 (1.811)	96.3 (3.791)	2.45 (5.4)			46 (1.811)	96.3 (3.791)	3.55 (7.8)		
2SM_8	8.5 (0.52)	48.1 (1.894)	100.5 (3.957)	2.60 (5.7)			48.1 (1.894)	100.5 (3.957)	3.70 (8.2)		
2SM_11	11 (0.67)	50.2 (1.976)	104.6 (4.118)	2.70 (6.0)			50.2 (1.976)	104.6 (4.118)	3.80 (8.4)		
2SM_14	14 (0.85)	52.7 (2.075)	109.6 (4.315)	2.80 (6.2)			52.7 (2.075)	109.6 (4.315)	3.90 (8.6)		
2SM_16	16.5 (1.01)	54.8 (2.157)	113.8 (4.480)	2.95 (6.5)			54.8 (2.157)	113.8 (4.480)	4.05 (8.9)		
2SM_19	19.5 (1.19)	57.3 (2.256)	118.8 (4.677)	3.10 (6.8)			57.3 (2.256)	118.8 (4.677)	4.20 (9.3)		
2SM_22	22.5 (1.37)	59.8 (2.354)	123.8 (4.874)	3.25 (7.2)			59.8 (2.354)	123.8 (4.874)	4.35 (9.6)		
2SM_26	26 (1.59)	62.7 (2.469)	129.6 (5.102)	3.40 (7.5)			62.7 (2.469)	129.6 (5.102)	4.50 (9.9)		

Dimensioni / Dimensions

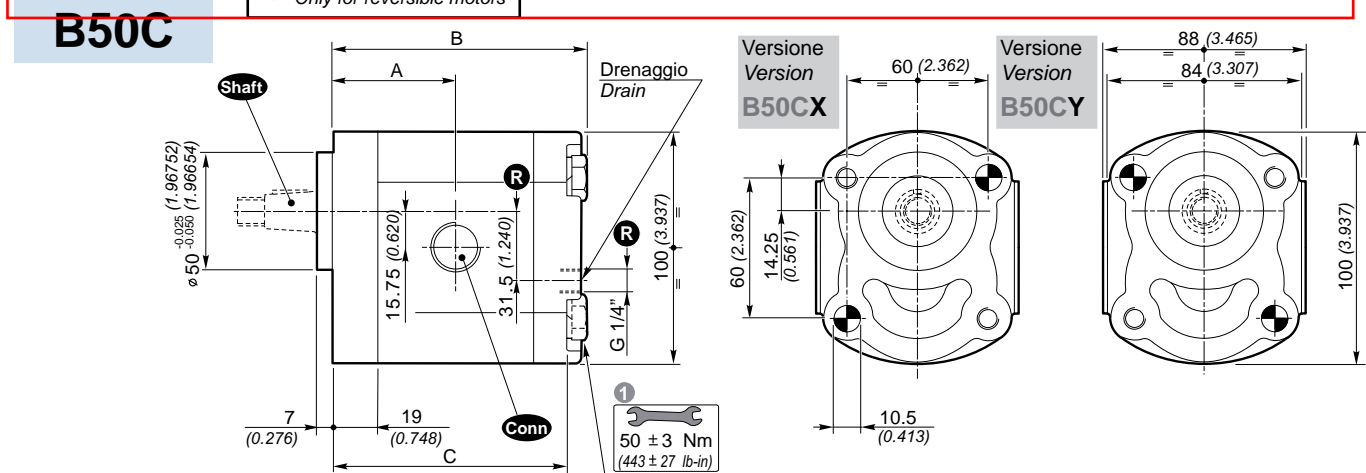
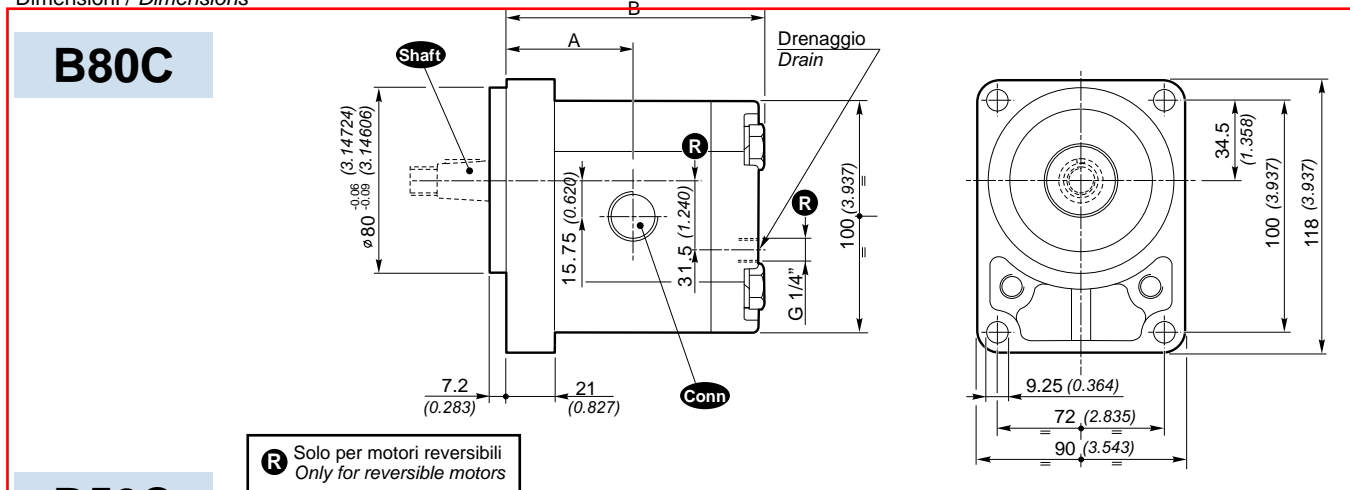

1 Coppia di serraggio viti: 50 ± 3 Nm. Utilizzare viti classe 10.9 - 12.9 UNI EN 20898/1.
Il fissaggio della pompa può essere effettuato con 2 viti prigioniere in materiale classe 10.9 - 12.9 preserrate a 40 ± 3 Nm.
Fissare la pompa mediante dadi autobloccanti con coppia di serraggio 50 ± 3 Nm.
Il Kit di viti per il fissaggio della pompa è da ordinare separatamente.
Codice di ordinazione del Kit di fissaggio:

1 Tightening torque of screws: 443 ± 27 lb-in. Use screws type 10.9 - 12.9 UNI EN 20898/1.
The assembling of the pump should be effected with 2 screw studs type 10.9 - 12.9 pre-tighten at 354 ± 27 lb-in.
Fix the pump by self-locking nuts with tightening torque 443 ± 27 lb-in.
The screws kit for the pump assembling should be ordered separately.
Ordering code of fixing Kit:

0029W + Lunghezza L (vedi tabella)
+ Length L (see table)

Grandezza Size	Cilindrata Displacement [cm³/rev] (in³/rev)	B80C			Shaft	Conn	B50C				Shaft	Conn	
		Dimensioni / Dimensions					Dimensioni / Dimensions						Massa Mass
		A [mm] (inch)	B [mm] (inch)	Massa [Kg] (lbs)			A [mm] (inch)	B [mm] (inch)	C [mm] (inch)	L 1 [mm] (inch)	[Kg] (lbs)		
2SM A4	4 (0.24)	46.4 (1.827)	95 (3.740)	2.30 (5.1)	10 11 12 13 14 15 16	G N T M U W F	44.4 (1.748)	93 (3.661)	84 (3.307)	105 (4.134)	2.30 (5.1)	10 11 12 13 14 15 16	G N T M U W F
2SM A6	6 (0.37)	48 (1.890)	98.3 (3.870)	2.45 (5.4)			46 (1.811)	96.3 (3.791)	87.3 (3.437)	105 (4.134)	2.45 (5.4)		
2SM A8	8.5 (0.52)	50.1 (1.972)	102.5 (4.035)	2.60 (5.7)			48.1 (1.894)	100.5 (3.957)	91.5 (3.602)	110 (4.331)	2.60 (5.7)		
2SM A11	11 (0.67)	52.2 (2.055)	106.6 (4.197)	2.70 (6.0)			50.2 (1.976)	104.6 (4.118)	95.6 (3.764)	115 (4.528)	2.70 (6.0)		
2SM A14	14 (0.85)	54.7 (2.154)	111.6 (4.394)	2.80 (6.2)			52.7 (2.075)	109.6 (4.315)	100.6 (3.961)	120 (4.724)	2.80 (6.2)		
2SM A16	16.5 (1.01)	56.8 (2.236)	115.8 (4.559)	2.95 (6.5)			54.8 (2.157)	113.8 (4.480)	104.8 (4.126)	125 (4.921)	2.95 (6.5)		
2SM A19	19.5 (1.19)	59.3 (2.335)	120.8 (4.756)	3.10 (6.8)			57.3 (2.256)	118.8 (4.677)	109.8 (4.323)	130 (5.118)	3.10 (6.8)		
2SM A22	22.5 (1.37)	61.8 (2.433)	125.8 (4.953)	3.25 (7.2)			59.8 (2.354)	123.8 (4.874)	114.8 (4.520)	135 (5.315)	3.25 (7.2)		
2SM A26	26 (1.59)	64.7 (2.547)	131.6 (5.181)	3.40 (7.5)			62.7 (2.469)	129.6 (5.102)	120.6 (4.748)	140 (5.512)	3.40 (7.5)		

MOTORI GRUPPO
MOTORS GROUP

2

Dimensioni / Dimensions

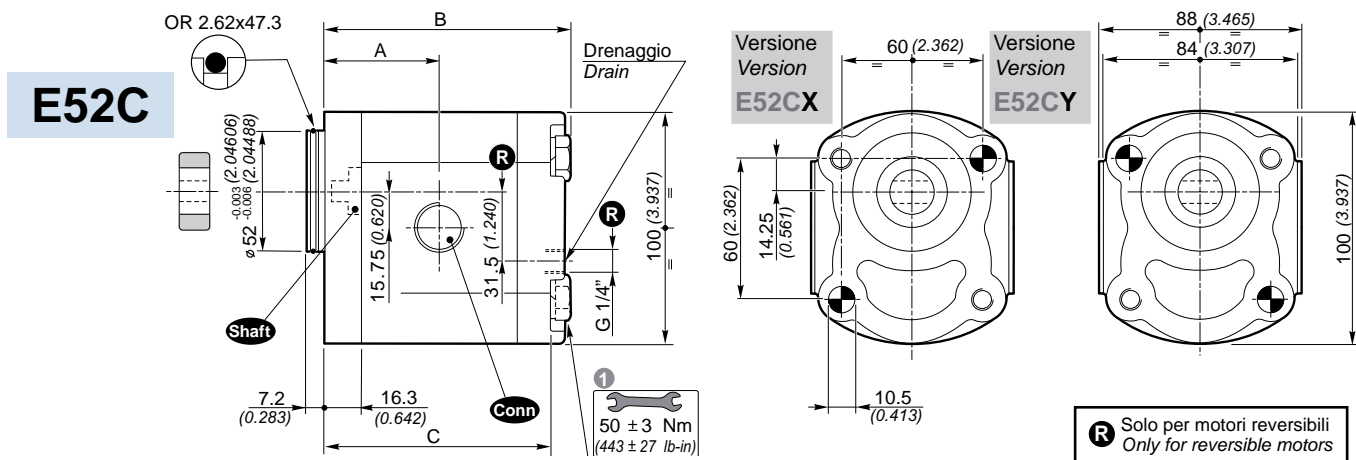

1
Coppia di serraggio viti: 50 ± 3 Nm. Utilizzare viti classe 10.9 - 12.9 UNI EN 20898/1.
Il fissaggio della pompa può essere effettuato con 2 viti prigioniere in materiale classe 10.9 - 12.9 preserrate a 40 ± 3 Nm.
Fissare la pompa mediante dadi autobloccanti con coppia di serraggio 50 ± 3 Nm.
Il Kit di viti per il fissaggio della pompa è da ordinare separatamente.
Codice di ordinazione del Kit di fissaggio:

1
Tightening torque of screws: 443 ± 27 lb-in. Use screws type 10.9 - 12.9 UNI EN 20898/1.
The assembling of the pump should be effected with 2 screw studs type 10.9 - 12.9 pre-tighten at 354 ± 27 lb-in.
Fix the pump by self-locking nuts with tightening torque 443 ± 27 lb-in.
The screws kit for the fixing of the pump should be ordered separately.
Ordering code of fixing Kit:

0029W + Lunghezza L (vedi tabella)
+ Length L (see table)

E52C								
Grandezza Size	Cilindrata Displacement [cm ³ /rev] (in ³ /rev)	Dimensioni / Dimensions				Massa Mass [Kg] (lbs)	Shaft	Conn
		A [mm] (inch)	B [mm] (inch)	C [mm] (inch)	L 1 [mm] (inch)			
2SM A4	4 (0.24)	41.7 (1.642)	90.3 (3.555)	81.3 (3.201)	100 (3.937)	2.30 (5.1)	17	G N T M U W F
2SM A6	6 (0.37)	43.3 (1.705)	93.6 (3.685)	84.6 (3.331)	105 (4.134)	2.45 (5.4)		
2SM A8	8.5 (0.52)	45.4 (1.787)	97.8 (3.850)	88.8 (3.496)	110 (4.331)	2.60 (5.7)		
2SM A11	11 (0.67)	47.5 (1.870)	101.9 (4.012)	92.9 (3.657)	115 (4.528)	2.70 (6.0)		
2SM A14	14 (0.85)	50 (1.969)	106.9 (4.209)	97.9 (3.854)	120 (4.724)	2.80 (6.2)		
2SM A16	16.5 (1.01)	52.1 (2.051)	111.1 (4.374)	102.1 (4.020)	120 (4.724)	2.95 (6.5)		
2SM A19	19.5 (1.19)	54.6 (2.150)	116.1 (4.571)	107.1 (4.217)	125 (4.921)	3.10 (6.8)		
2SM A22	22.5 (1.37)	57.1 (2.248)	121.1 (4.768)	112.1 (4.413)	130 (5.118)	3.25 (7.2)		
2SM A26	26 (1.59)	60 (2.362)	126.9 (4.996)	117.9 (4.642)	140 (5.512)	3.40 (7.5)		

Dimensioni / Dimensions

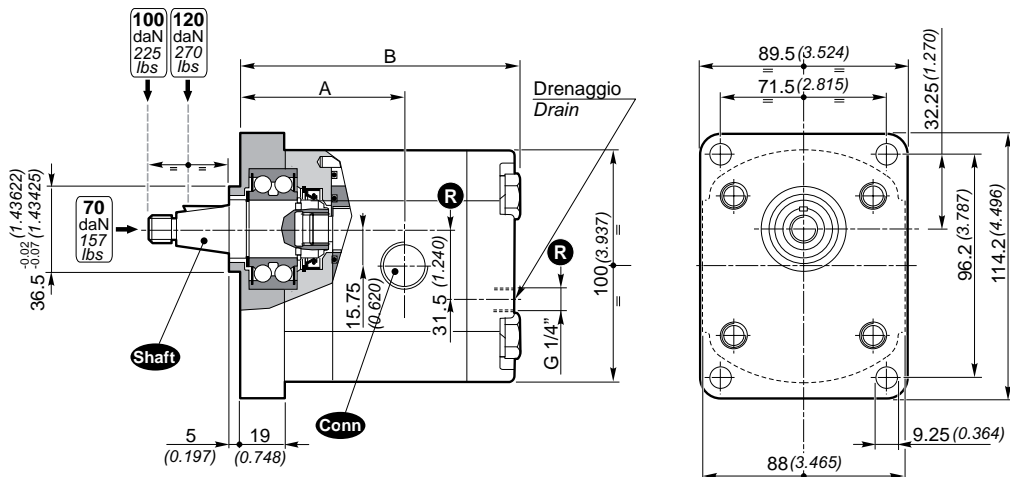

Versione da utilizzare in presenza di carichi assiali e/o radiali
Version to use with axial and/or radial loads

R Solo per motori reversibili
Only for reversible motors

SUPP.STND

Grandezza Size	Cilindrata Displacement [cm ³ /rev] [in ³ /rev]	Dimensioni / Dimensions		Massa Mass [Kg] [lbs]	Shaft	Conn		
		A [mm] [inch]	B [mm] [inch]					
2SM A4	4 (0.24)	64.4 (2.535)	113 (4.449)	2.80 (6.2)	10	G N T M U V F		
2SM A6	6 (0.37)	66 (2.598)	116.3 (4.579)	2.88 (6.4)				
2SM A8	8.5 (0.52)	68.1 (2.681)	120.5 (4.744)	3.00 (6.6)				
2SM A11	11 (0.67)	70.2 (2.764)	124.6 (4.906)	3.12 (6.9)				
2SM A14	14 (0.85)	72.7 (2.862)	129.6 (5.102)	3.27 (7.2)				
2SM A16	16.5 (1.01)	74.8 (2.945)	133.8 (5.268)	3.39 (7.5)				
2SM A19	19.5 (1.19)	77.3 (3.043)	138.8 (5.465)	3.53 (7.8)				
2SM A22	22.5 (1.37)	79.8 (3.142)	143.8 (5.661)	3.67 (8.1)				
2SM A26	26 (1.59)	82.7 (3.256)	149.6 (5.890)	3.84 (8.5)			C-11	C-12

OPZIONI / OPTIONAL

MOTORI GRUPPO MOTORS GROUP

2

VLP- I (N)

Valvola limitatrice di pressione a scarico interno
Pressure relief valve with internal exhaust

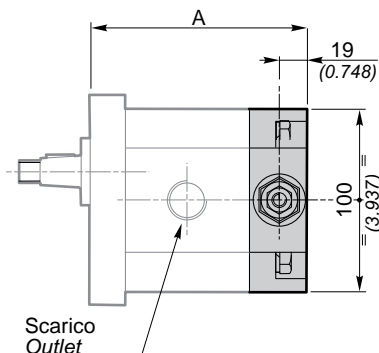
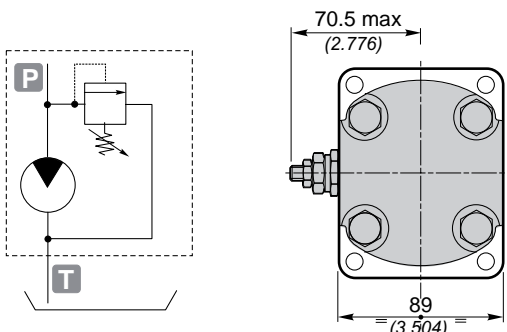

	A		
	Standard SAE A B50C	B80C	E52C
2SM A4	104.8 (4.126)	106.8 (4.205)	102.1 (4.020)
2SM A6	108.1 (4.256)	110.1 (4.335)	105.4 (4.150)
2SM A8	112.3 (4.421)	114.3 (4.500)	109.6 (4.315)
2SM A11	116.4 (4.583)	118.4 (4.661)	113.7 (4.476)
2SM A14	121.4 (4.780)	123.4 (4.858)	118.7 (4.673)
2SM A16	125.6 (4.945)	127.6 (5.024)	122.9 (5.035)
2SM A19	130.6 (5.142)	132.6 (5.220)	127.9 (5.035)
2SM A22	135.6 (5.339)	137.6 (5.417)	132.9 (5.232)
2SM A26	141.4 (5.567)	143.4 (5.646)	138.7 (5.461)

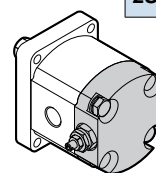

VLP- E (N)

Valvola limitatrice di pressione a scarico esterno
Pressure relief valve with external exhaust

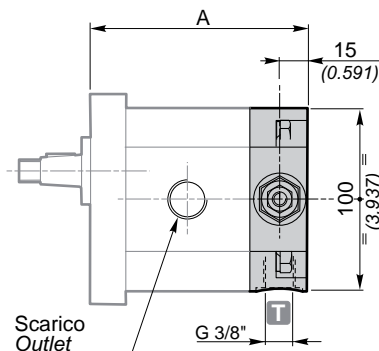
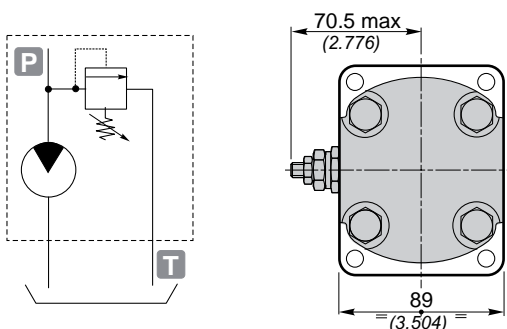

	A		
	Standard SAE A B50C	B80C	E52C
2SM A4	100.8 (3.969)	102.8 (4.047)	98.1 (3.862)
2SM A6	104.1 (4.098)	106.1 (4.177)	101.4 (3.992)
2SM A8	108.3 (4.264)	110.3 (4.343)	105.6 (4.157)
2SM A11	112.4 (4.425)	114.4 (4.504)	109.7 (4.319)
2SM A14	117.4 (4.622)	119.4 (4.701)	114.7 (4.516)
2SM A16	121.6 (4.787)	123.6 (4.866)	118.9 (4.681)
2SM A19	126.6 (4.984)	128.6 (5.063)	123.9 (4.878)
2SM A22	131.6 (5.181)	133.6 (5.260)	128.9 (5.075)
2SM A26	137.4 (5.409)	139.4 (5.488)	134.7 (5.303)

NB.

La valvola limitatrice di pressione si applica sostituendo il coperchio posteriore.
Fornitura solo con flangia e coperchio in Alluminio.
Sono rappresentati motori con rotazione destra.
Nei motori con rotazione destra, il foro T è in alto.

L'apertura della valvola limitatrice di pressione deve avvenire per tempi non superiori ai 10 secondi ogni minuto per evitare il surriscaldamento della pompa.

Warning.

The pressure relief valve can be applied by substituting the rear cover.
It is supplied only with aluminium flange and cover.
The showed motors are clockwise rotation.
Motors with clockwise rotation, T port is above.

The opening of the pressure relief valve should be carry out for times not over 10" each minute to avoid the overheating of the pump.

Esempio di ordinazione in codice / Example of ordering code

2SM	A	14	D	SAE A	-	10	G	(VT)	VLP-I	(N)
VLP-I	Coperchio con VLP Cover with VLP			VLP-I (a scarico interno / at internal exhaust) VLP-E (a scarico esterno / at external exhaust)						
(N)	Tipo di molla / Spring type			B - N - R (vedi tabella / See table)						

		Tipo di molla / Spring type		
		B	N	R
		molla bianca white spring	molla nera black spring	molla rossa red spring
Campi di taratura* Calibration fields*	[bar] (psi)	10 ÷ 100 (145 ÷ 1450)	30 ÷ 280 (435 ÷ 4060)	80 ÷ 380 (1160 ÷ 5510)

* In caso di omissione del valore di taratura, esso sarà inteso standard (molla nera con taratura 150 bar).

* Without setting request, it will be considered standard (black spring: 2175 psi).

Motore unidirezionale a due velocità con valvola limitatrice di pressione VLP
Two speed unidirectional motors with VLP pressure relief valve

Configurazione per rotazione destra
Configuration for clockwise rotation

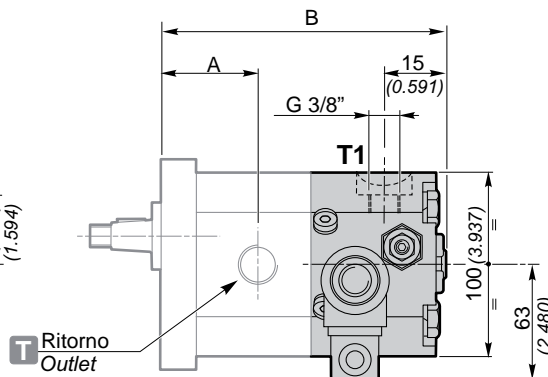
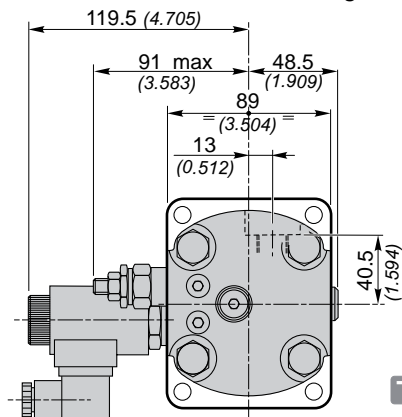
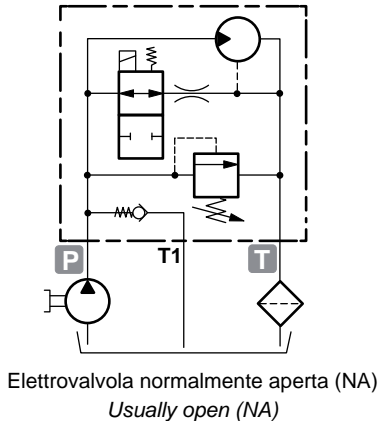

Configurazione per rotazione sinistra
Configuration for anticlockwise rotation

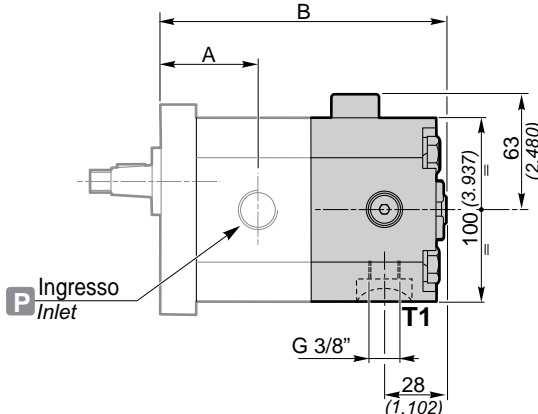
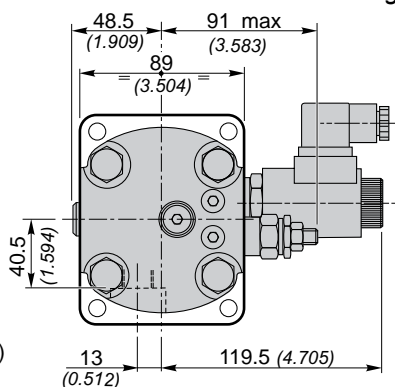
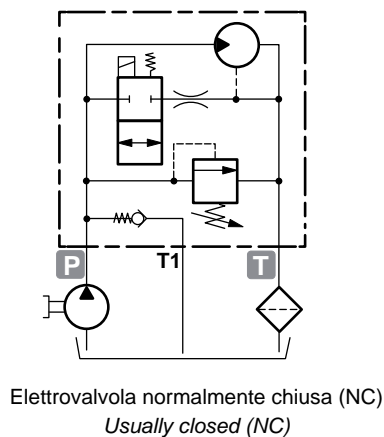

	2SM A4	2SM A6	2SM A8	2SM A11	2SM A14	2SM A16	2SM A19	2SM A22	2SM A26
A	44.4 (1.748)	46 (1.811)	48.1 (1.894)	50.2 (1.976)	52.7 (2.075)	54.8 (2.157)	57.3 (2.256)	59.8 (2.354)	62.7 (2.469)
B	142.3 (5.602)	145.6 (5.732)	149.8 (5.898)	153.9 (6.059)	158.9 (6.256)	163.1 (6.421)	168.1 (6.618)	173.1 (6.815)	182 (7.165)

Esempio di ordinazione in codice / Example of ordering code

2SM	A14	D	NA	(24VDC)	VLP	(N)	SAE A	-	10	G
-----	-----	---	----	---------	-----	-----	-------	---	----	---

NA	NA = Normalmente aperta / Usually open NC = Normalmente chiusa / Usually closed	NA = Normalmente aperta / Usually open NC = Normalmente chiusa / Usually closed
24VDC	Tensione magnete / Electromagnete voltage	12 - 24 - 48 V. DC 24 - 48 - 110 - 220 V. AC (50 Hz)
VLP	Coperchio con VLP Cover with VLP	
(N)	Tipo di molla / Spring type	B - N - R (vedi tabella / See table)

N.B.
Solo per motori con flangia e coperchio in Alluminio
Only motors with flange and cover in Aluminium

		Tipo di molla / Spring type		
		B	N	R
		molla bianca white spring	molla nera black spring	molla rossa red spring
Campi di taratura* Calibration fields*	[bar] (psi)	10 ÷ 100 (145 ÷ 1450)	30 ÷ 280 (435 ÷ 4060)	80 ÷ 380 (1160 ÷ 5510)

* In caso di omissione del valore di taratura, esso sarà inteso standard (molla nera con taratura 150 bar).

* Without setting request, it will be considered standard (black spring: 2175 psi).

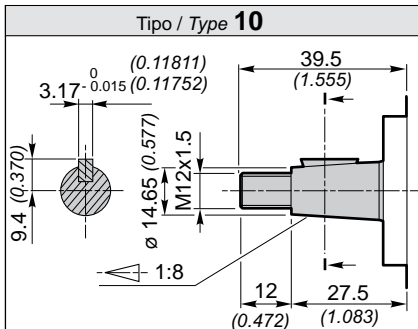

Coppia 98 Nm / Torque 72.3 ft-lbs

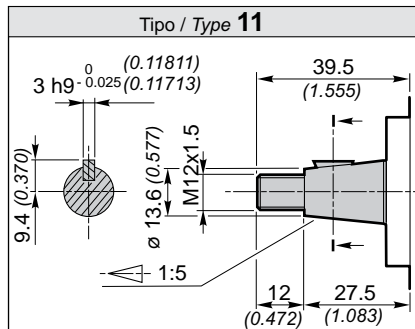

Coppia 98 Nm / Torque 72.3 ft-lbs

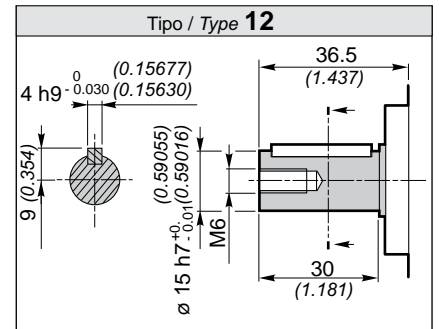

Coppia 98 Nm / Torque 72.3 ft-lbs

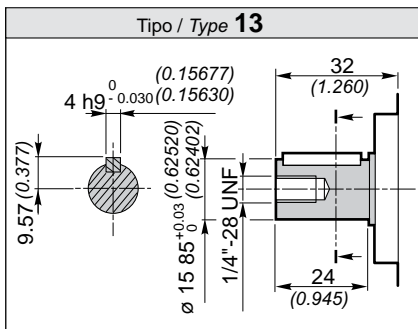

Coppia 98 Nm / Torque 72.3 ft-lbs

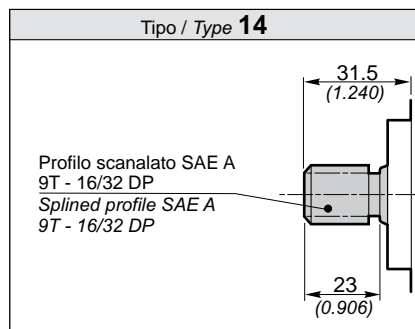

Coppia 98 Nm / Torque 72.3 ft-lbs

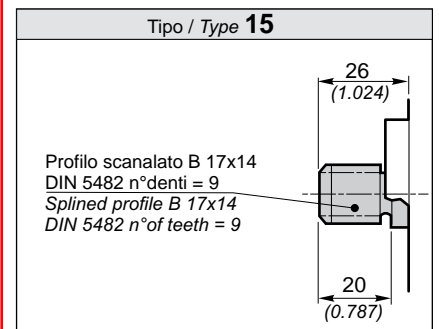

Coppia 98 Nm / Torque 72.3 ft-lbs

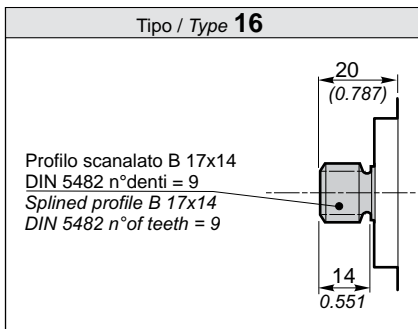

Coppia 98 Nm / Torque 72.3 ft-lbs

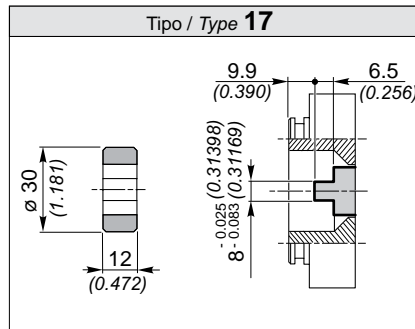

Coppia 70 Nm / Torque 51.6 ft-lbs

MOTORI GRUPPO
MOTORS GROUP

2

CONNESSIONI per motori D-S
CONNECTIONS for D-S motors

Conn

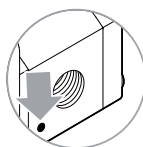
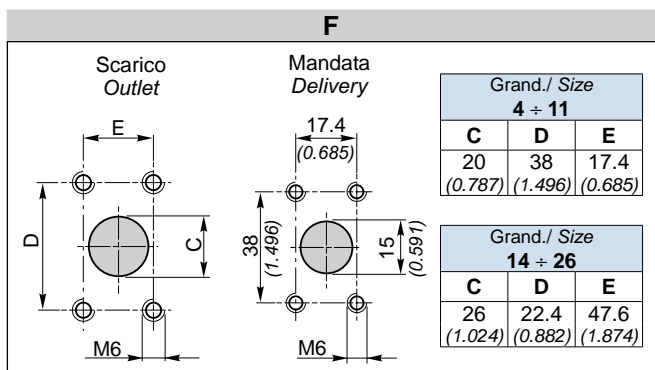
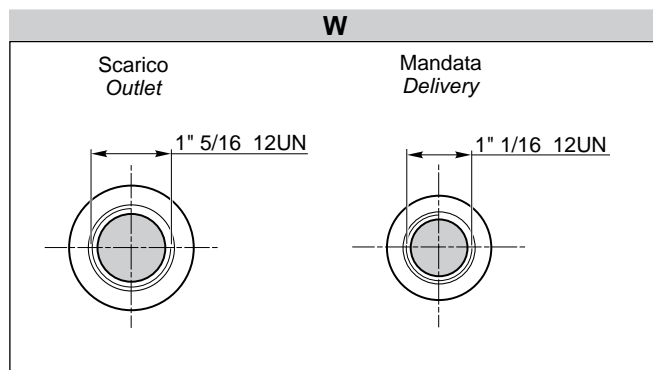
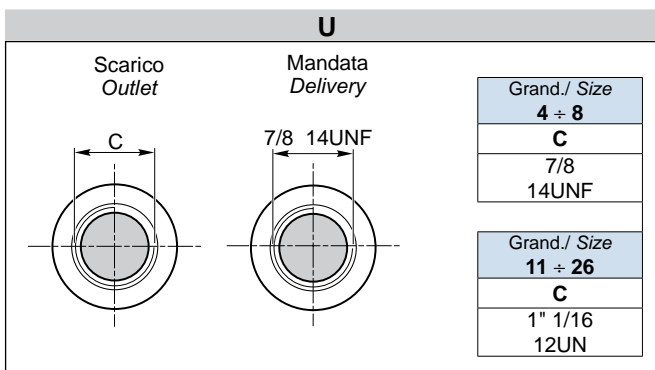
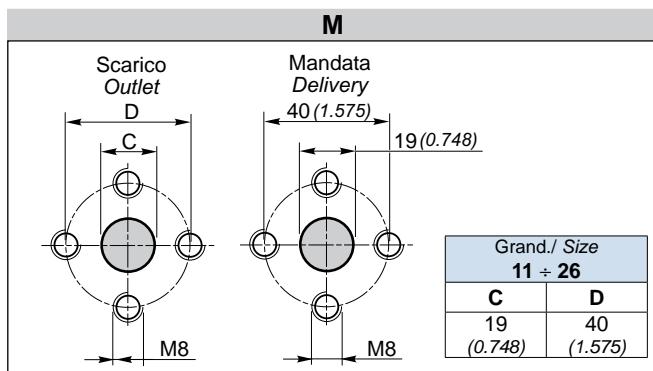
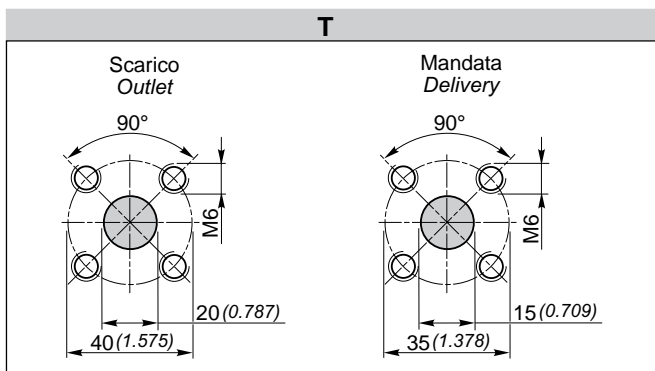
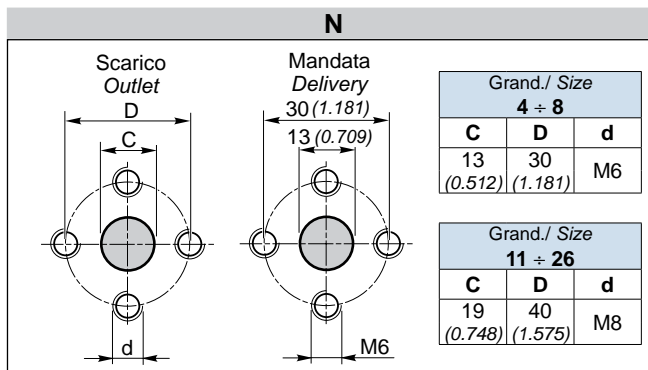
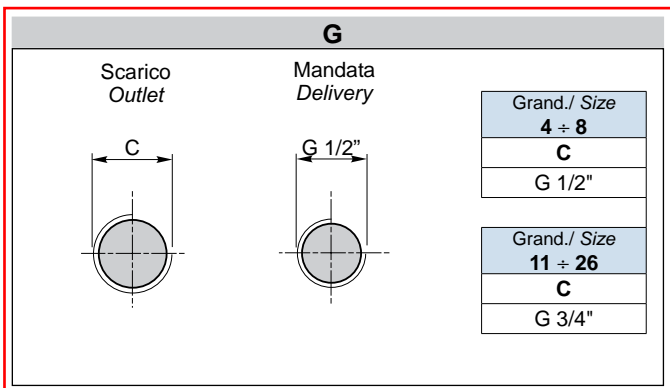

Il segno sul corpo indica il lato scarico per i motori.
The sign on the body identify the **outlet side** for the motors.

Posizione delle connessioni / Connections positions

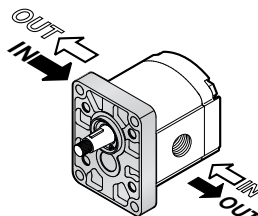

Rotazione / Rotation	
D	S

G

Mandata / Scarico
Delivery / Outlet

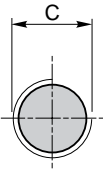

Grand./ Size	
4 ÷ 8	
C	
G 1/2"	
Grand./ Size	
11 ÷ 26	
C	
G 3/4"	

N

Mandata / Scarico
Delivery / Outlet

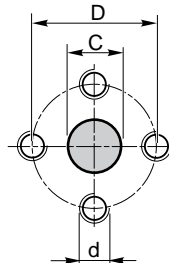

Grand./ Size		
4 ÷ 8		
C	D	d
13 (0.512)	30 (1.181)	M6
Grand./ Size		
11 ÷ 26		
C	D	d
19 (0.748)	40 (1.575)	M8

T

Mandata / Scarico
Delivery / Outlet

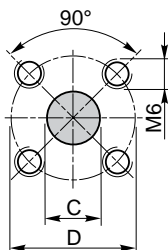

Grand./ Size	
4 ÷ 8	
C	D
15 (0.591)	35 (1.378)
Grand./ Size	
11 ÷ 26	
C	D
20 (0.787)	40 (1.575)

U

Mandata / Scarico
Delivery / Outlet

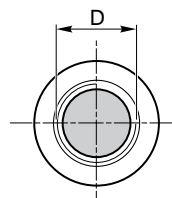

Grand./ Size	
4 ÷ 8	
D	
7/8	
14UNF	
Grand./ Size	
11 ÷ 26	
D	
1" 1/16	
12UN	

F

Mandata / Scarico
Delivery / Outlet

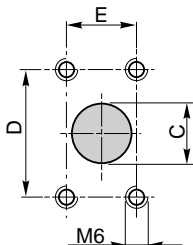

Grand./ Size		
4 ÷ 11		
C	D	E
20 (0.787)	38 (1.496)	17.4 (0.685)
Grand./ Size		
14 ÷ 26		
C	D	E
26 (1.024)	22.4 (0.882)	47.6 (1.874)

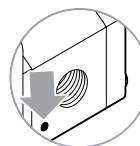

L'eventuale segno sul corpo dei motori reversibili non è da considerare.
Any sign on the body in reversible motors is not considered.

Posizione delle connessioni / Connections positions

