



MOULDING



INTRODUCTION TO MOULDING

- In 1860's there was invention of the first plastic , "Cellulose Nitrate" .
- Plastics are hydrocarbons consisting of large chains of Carbon and Hydrogen atoms.
- Plastics do not resemble each other in appearance or characteristics.

There are two types of plastics:

- Thermo plastics.
- Thermo set plastics.



THERMO PLASTICS

- Thermo plastic is also known as thermo softening plastic.
- It is a polymer that turns to liquid when heated and freezes to a very glassy state when cooled sufficiently.
- Thermo plastic polymers differ from thermosetting polymers (bakelite) in that they can be remelted and remoulded.

Eg: polyethylene and polypropylene.

THERMOSET PLASTIC

- A thermosetting plastic, also known as a thermo set, is a polymer material that irreversibly cures.
- The cure may be done through heat (Generally above 200degree celcius) , or through chemical reaction or irradiation such as electron beam processing.

Difference between thermoplastic and thermosetting polymers

Thermoplastic polymers

- (1) These soften and melt on heating.
- (2) These can be remolded recast and reshaped.
- (3) These are less brittle and soluble in some organic solvents.
- (4) These are formed by addition polymerization.
- (5) These have usually linear structures.
- Ex. Polyethylene, PVC, teflon.

Thermosetting polymers

- These do not soften on heating but rather become hard in case prolonged heating is done these start burning.
- These can not be remolded or reshaped.
- These are more brittle and insoluble in organic solvents.
- These are formed by condensation polymerization.
- These have three dimensional cross linked structures. Ex. Bakelite, urea, formaldehyde, resin

MOULD

- A Mould is a hollow form or cavity into which molten plastic material is forced to give the shape of the required component.
- The term generally refers to the whole assembly of parts which go to make up the section of the injection moulding equipment in which plastic components are moulded.

CLASSIFICATION OF MOULD

- Depending on the material to be processed moulds are classified into
 - Injection moulds (for thermo plastic)
 - Thermo set moulds
 - Elastomer (rubber) moulds
 - Structural form moulds

MOULDS



COMMONLY USED MOULDING METHODS

- Injection Moulding
- Compression Moulding
- Transfer Moulding
- Blow Moulding
- Extrusion Moulding
- Rotational Moulding
- Thermo Forming

INJECTION MOULDING

- Injection moulding is a manufacturing process for producing parts from both thermo plastic and thermosetting materials .
- Material is fed into the heated barrel , mixed and forced into a mould cavity where it cools and hardens to the configuration of the cavity .

INJECTION MOULDING

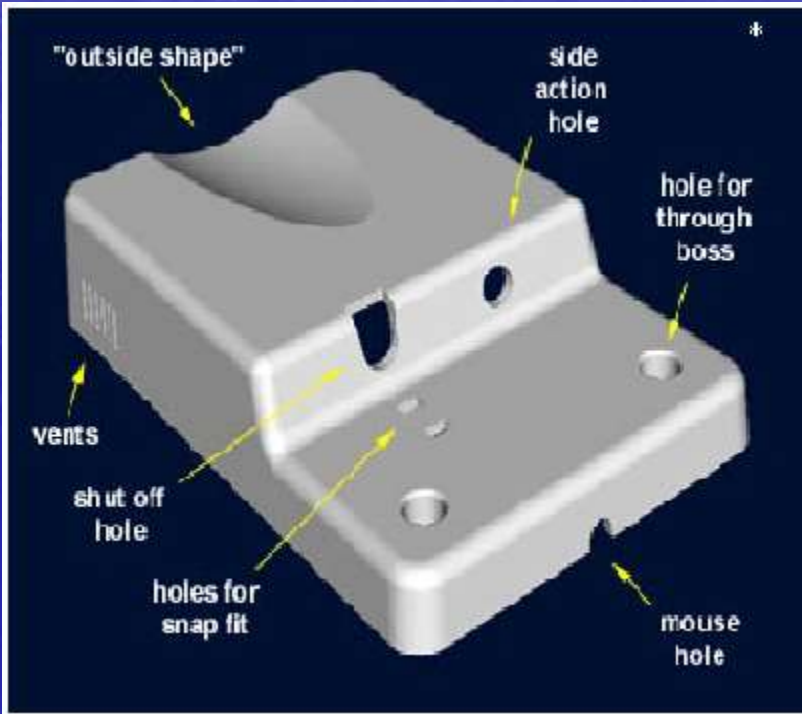
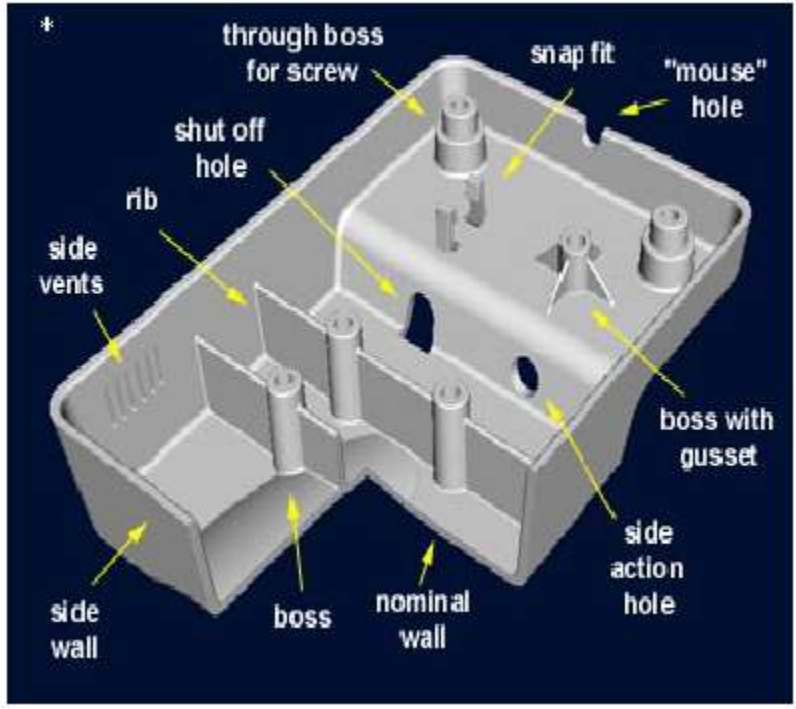

INJECTION MOULDING M/C



Injection Molding Machine

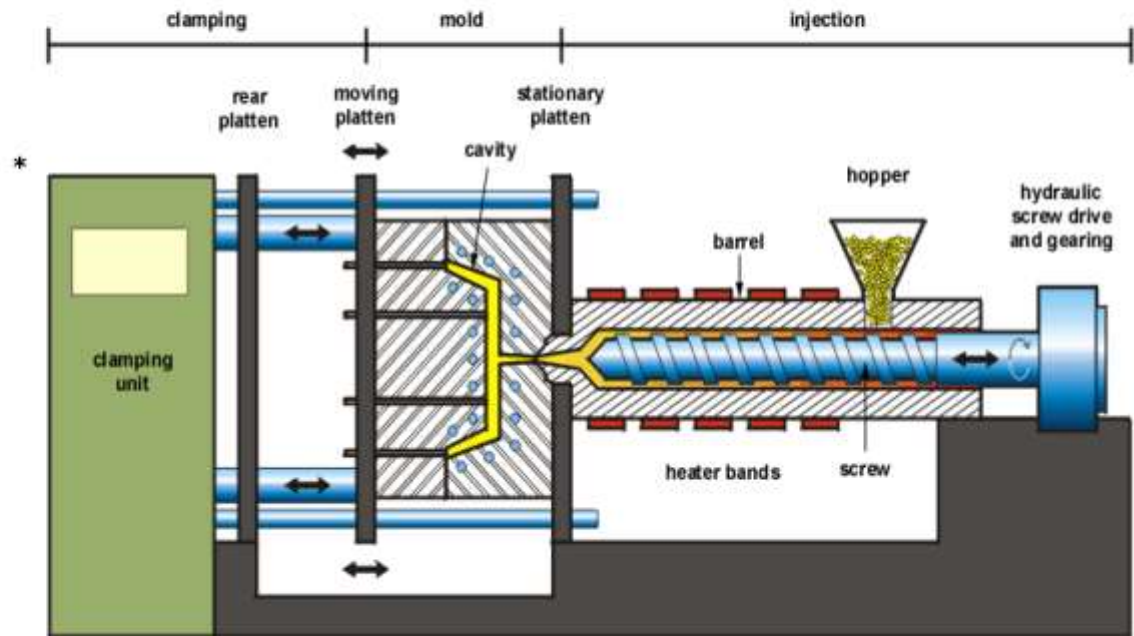
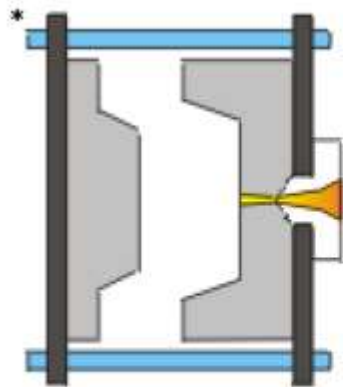

Schematic of thermoplastic Injection molding machine

INJECTION MOULDING M/C

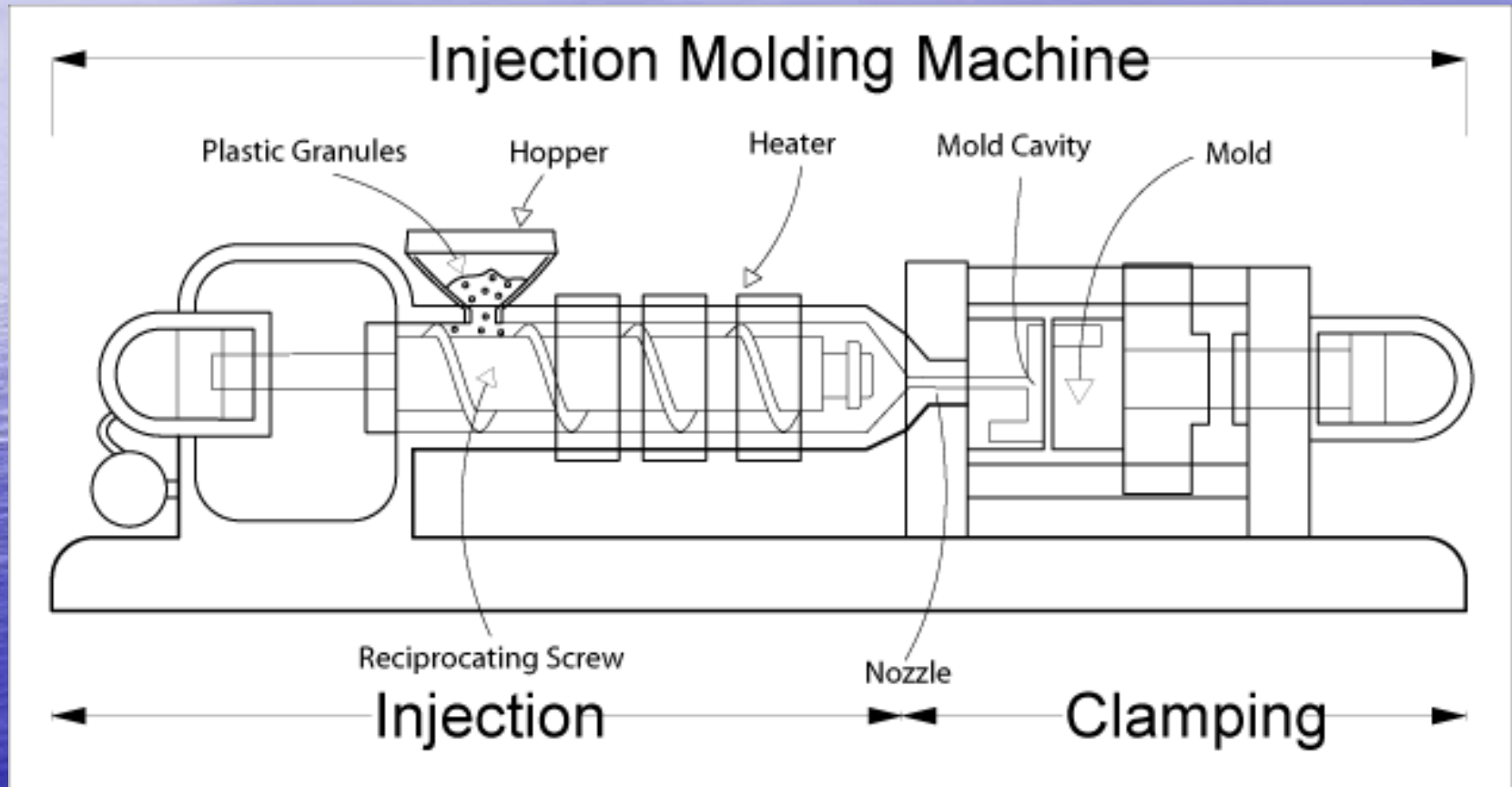

INJECTION PROCESS

- With injection molding, granular plastic is fed by gravity from a hopper into a heated barrel.
- As the granules are slowly moved forward by a screw-type plunger, the plastic is forced into a heated chamber, where it is melted.
- As the plunger advances, the melted plastic is forced through a nozzle that rests against the mold, allowing it to enter the mold cavity through a gate and runner system.

TOOLING FOR A PLASTIC

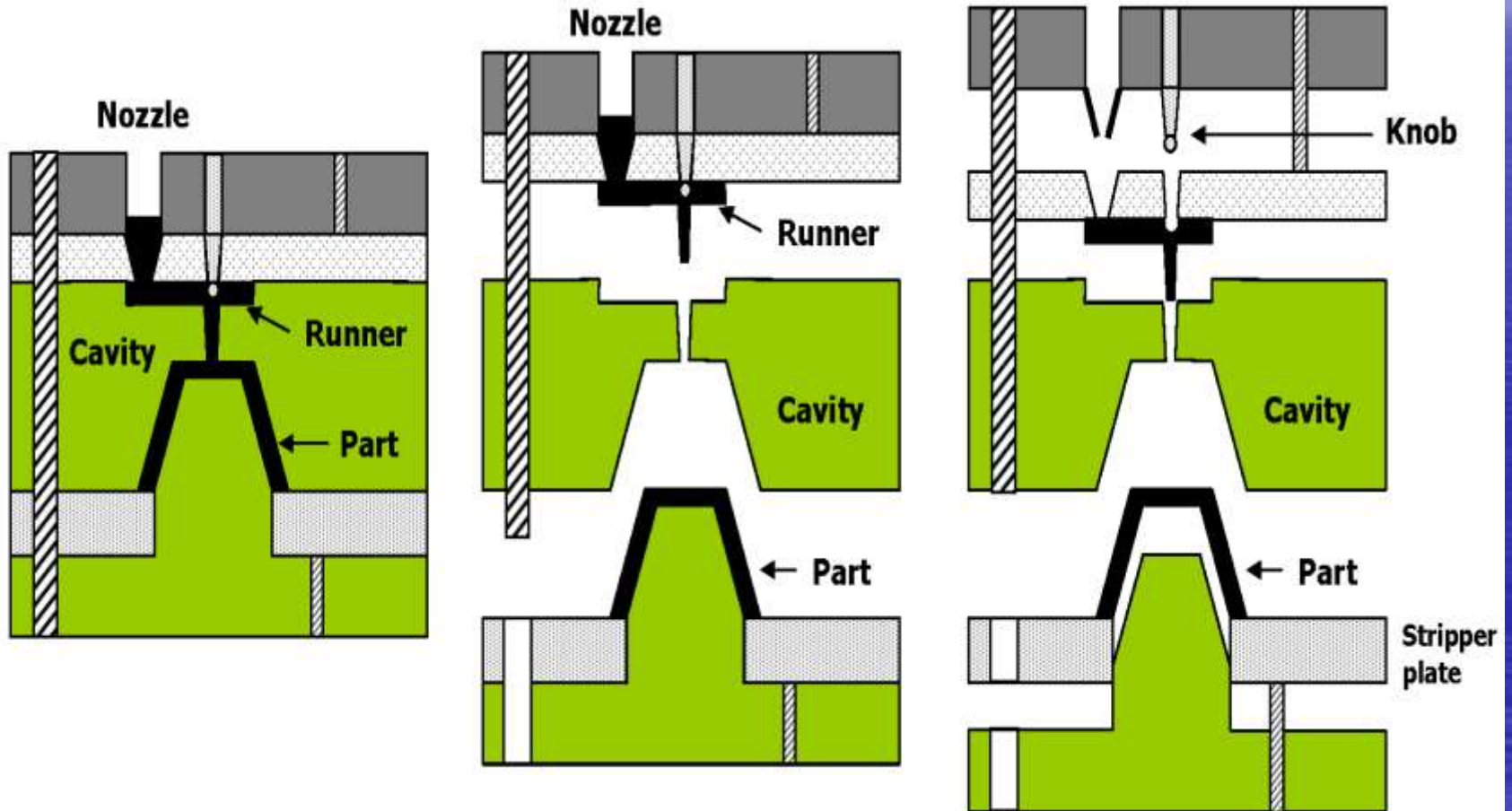

HOPPER



NOZZLE TIP TYPES

General Purpose

For use with styrene, polyethylene and other general-purpose materials

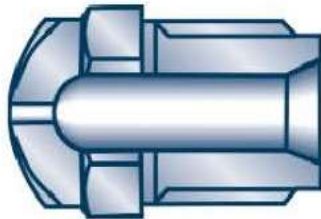

Full-Taper

For use with ABS, acrylics, polycarbonate, sulfone and other engineering materials

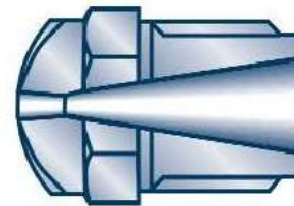

Nylon

Minimizes drool when molding with nylon

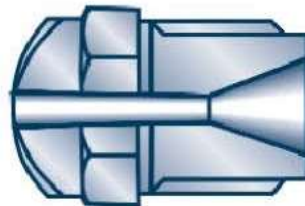

AVOID LONG REACH NOZZLE AND TIPS

- Cold slug
- Burning
- Splay
- Pressure loss

COMPRESSION MOULDING

- Compression moulding is the method adopted to mould thermoset plastic materials .
- Here the material is loaded in a separate chamber called loading well , heated and cured to form a component .

Compression Molding

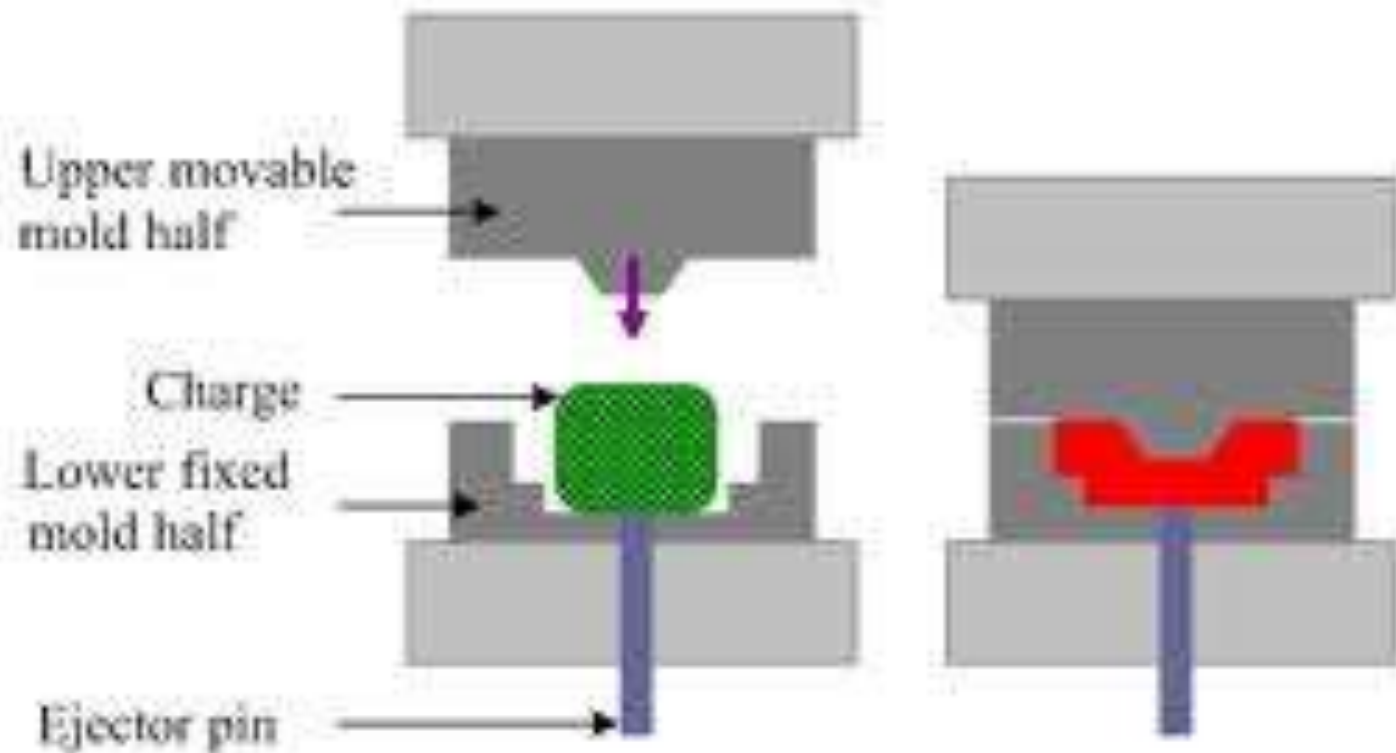

TRANSFER MOULDING

- In this type , thermoset material is loaded in separate chamber and made to flow through sprues , runner , gates and to the impression.
- Transfer moulding method mainly consists of two types
 - Pot transfer moulding
 - Plunger transfer moulding

Transfer Molding

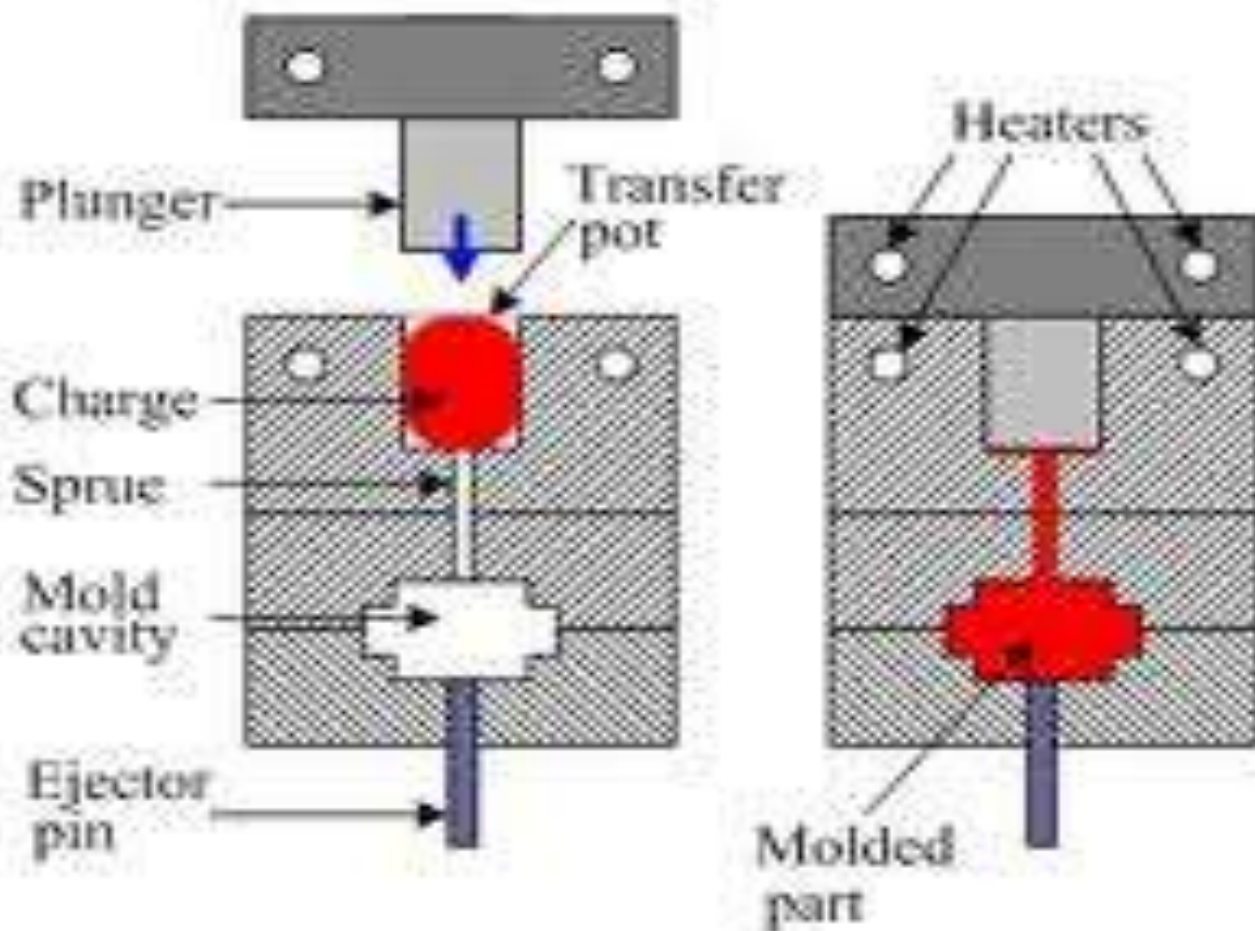

BLOW MOULDING

- Blow moulding or blow forming is a manufacturing process by which hollow plastic parts are formed .
- In general there are three main types of blow moulding
 - Extrusion blow moulding
 - Injection blow moulding
 - Stretch blow moulding

BLOW MOULDING

- The blow moulding process begins with melting down the plastic and forming it into a parison or pre form .
- The parison is a tube like piece of plastic with a hole in one end in which compressed air can pass through .
- The parison is then clamped into a mould and air is passed into it .
- The air pressure then pushes the plastic out to match the mould .

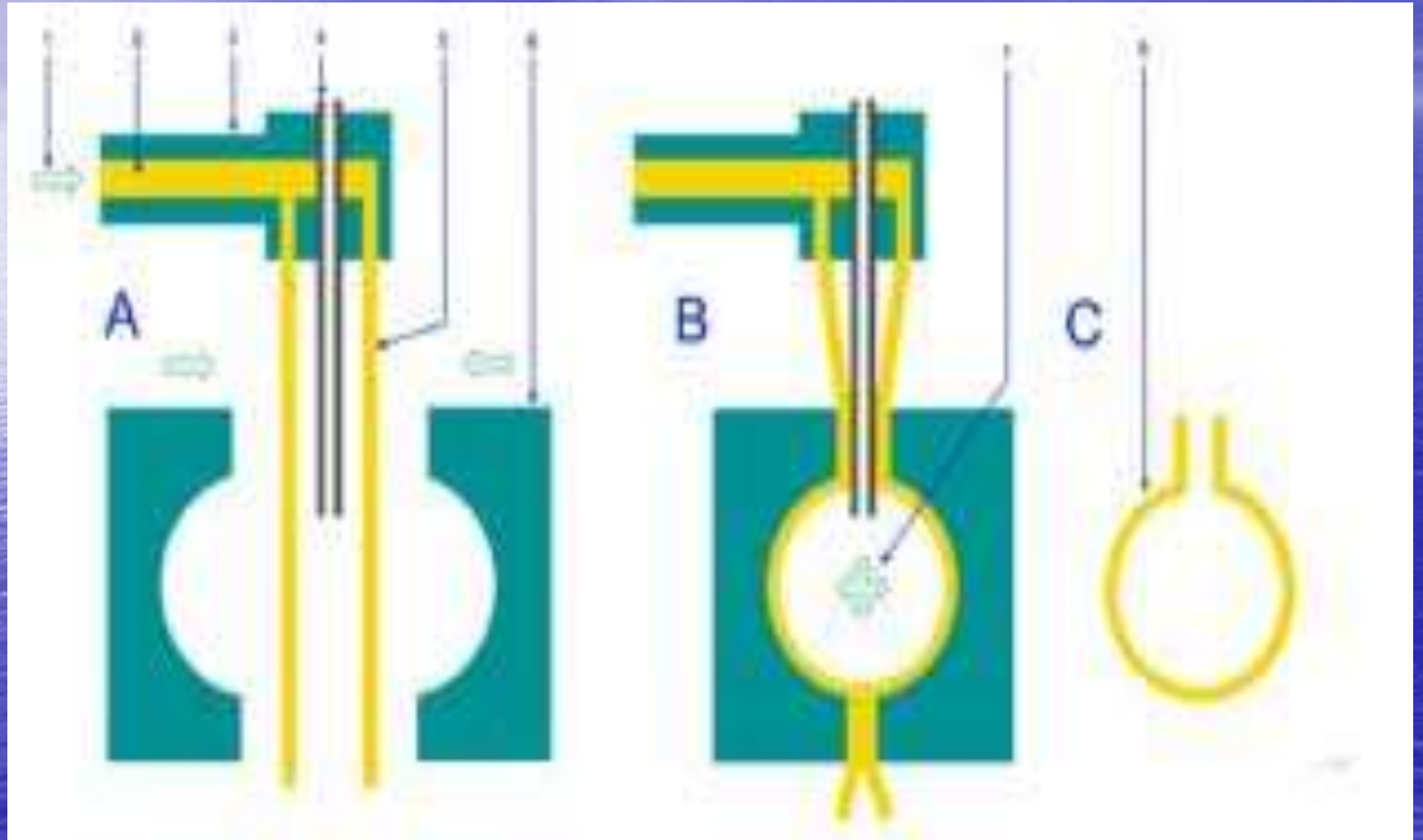

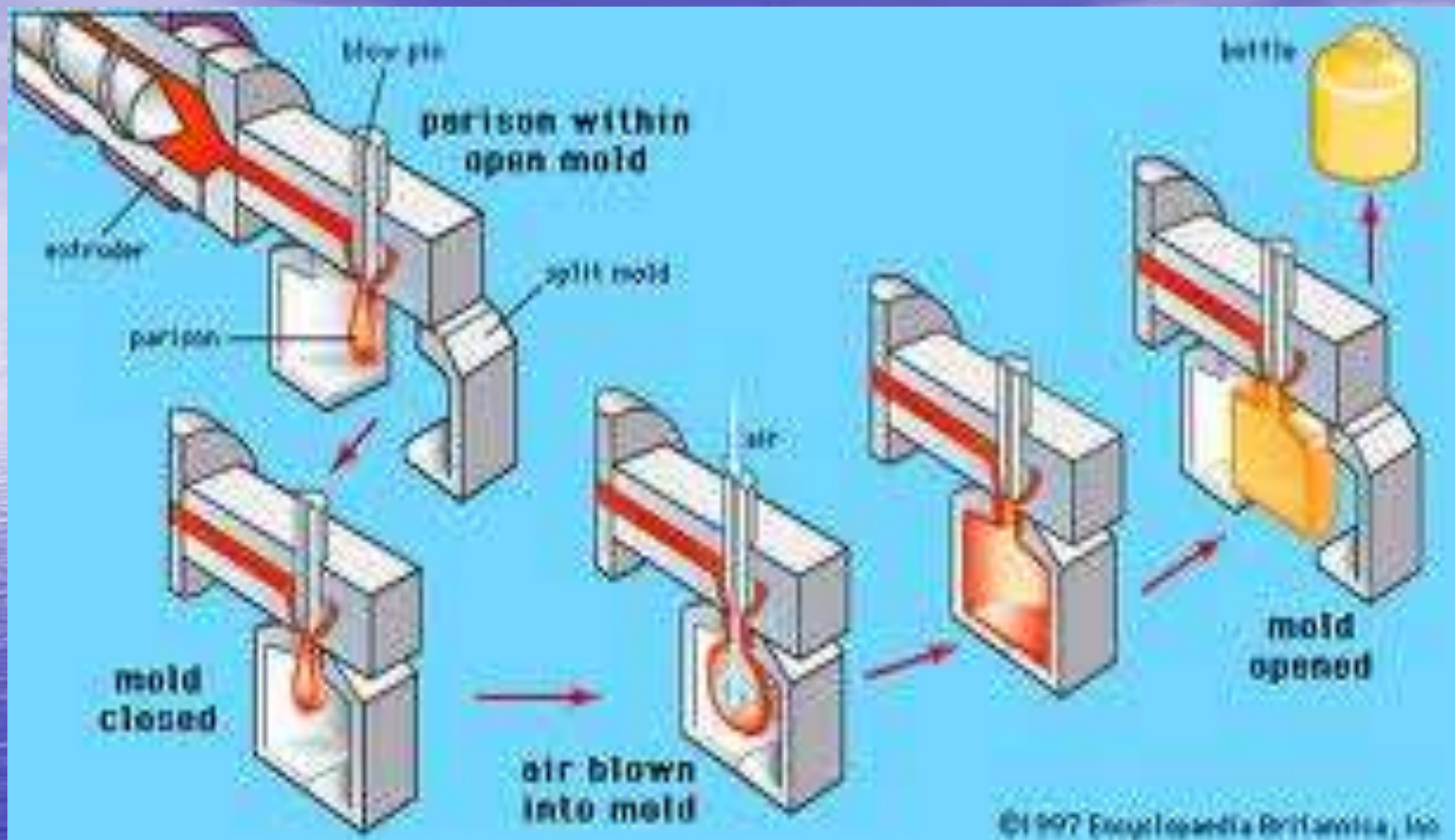

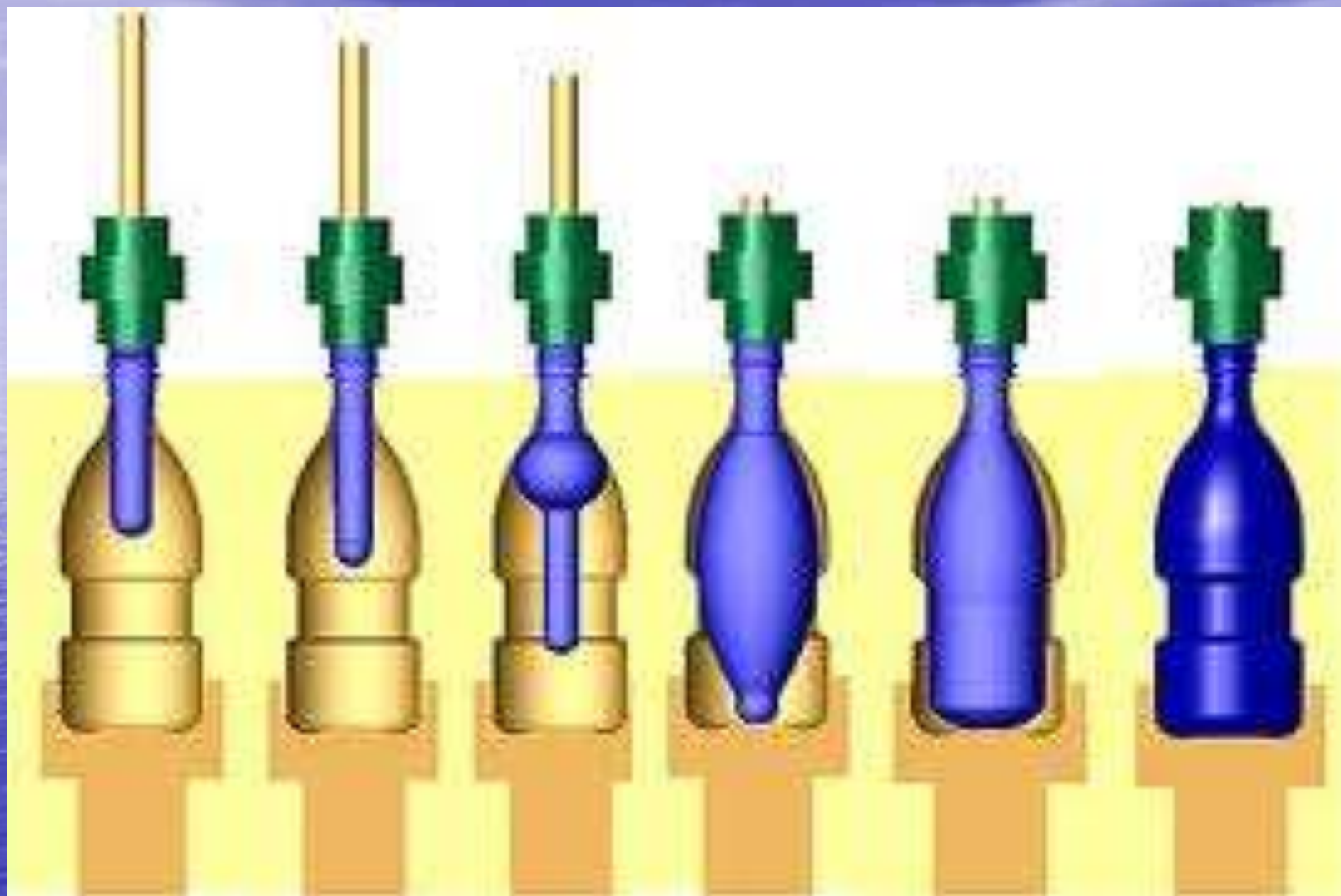

INJECTION BLOW MOULDING

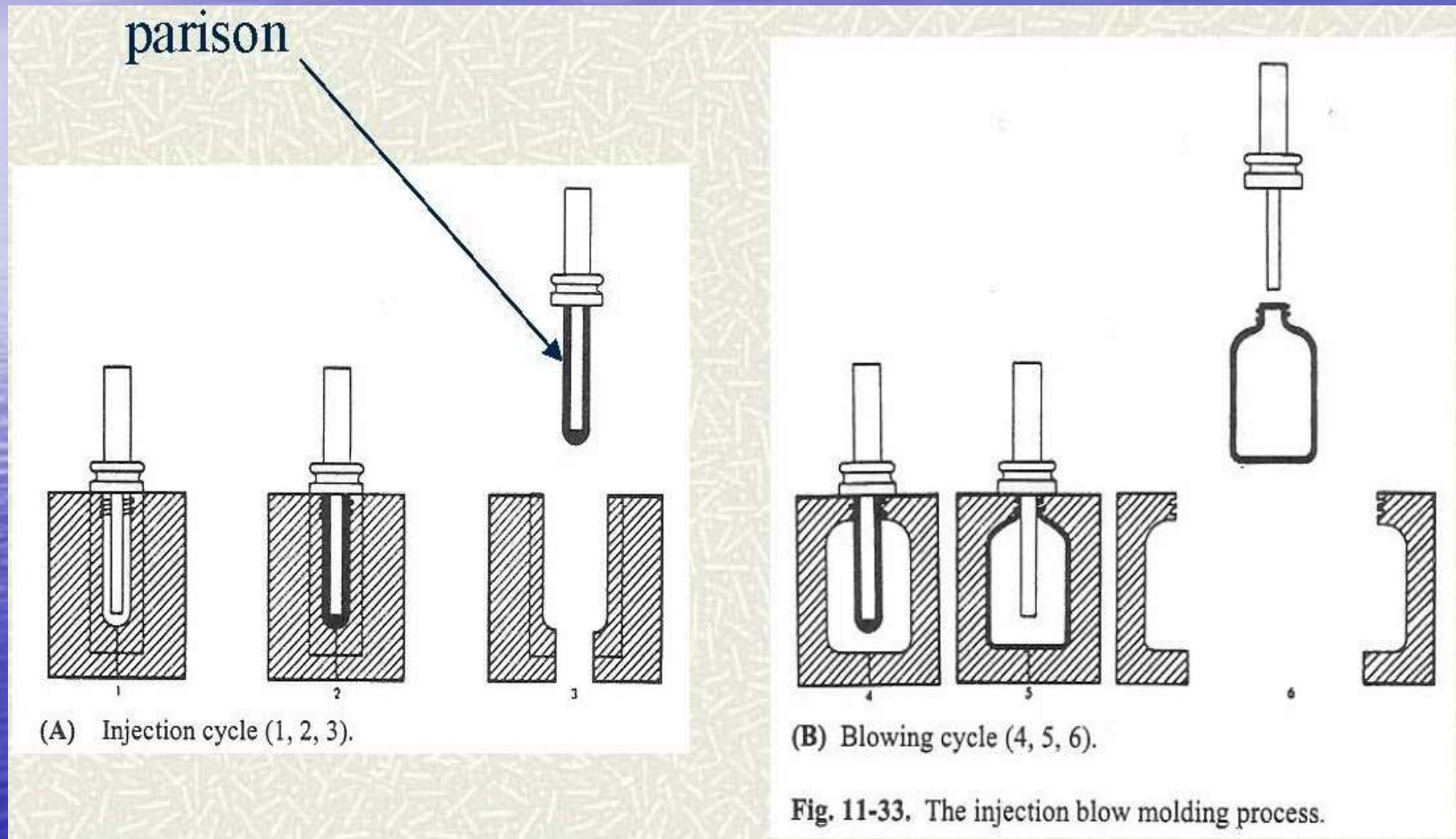

Fig. 11-33. The injection blow molding process.

EXTRUSION BLOW MOULDING

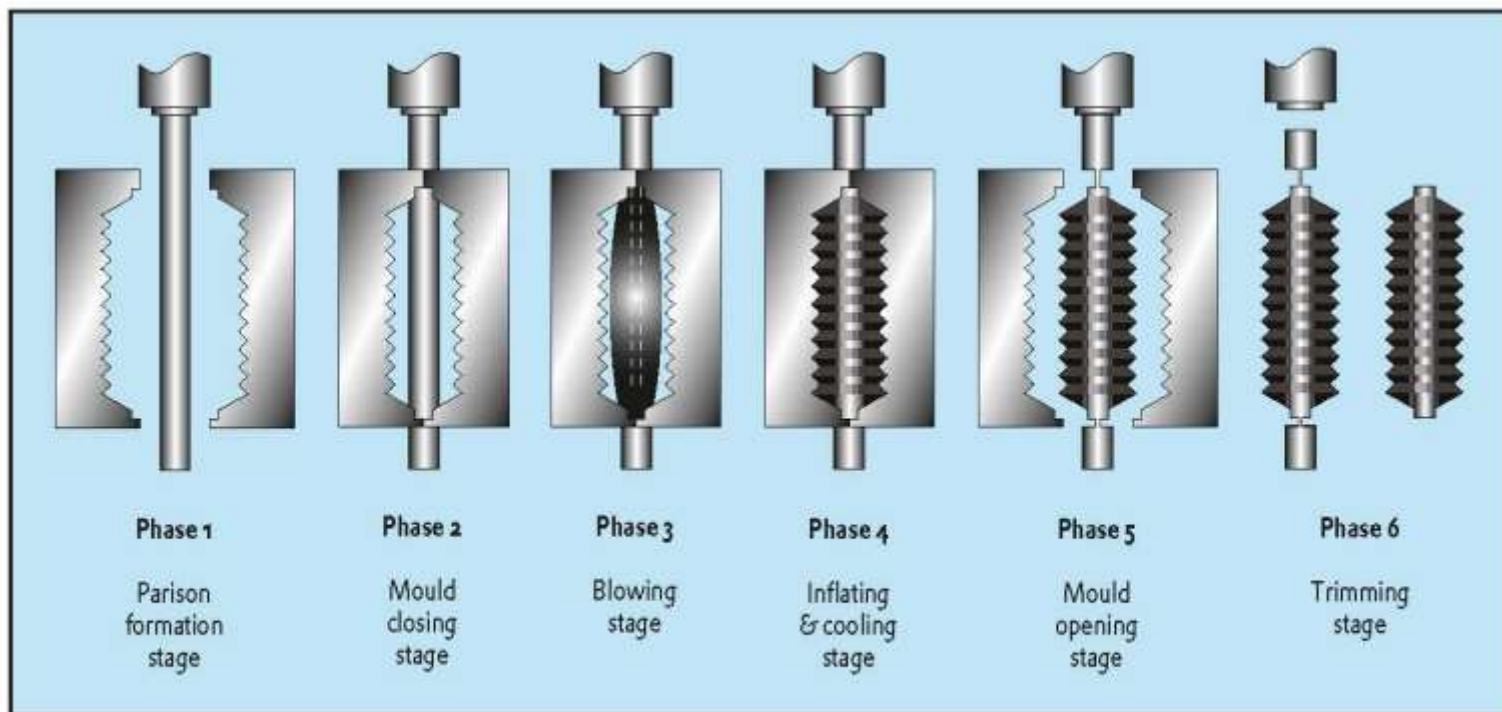

Fig. 2 - Overview of the extrusion blow moulding process

EXTRUSION BLOW MOULDING

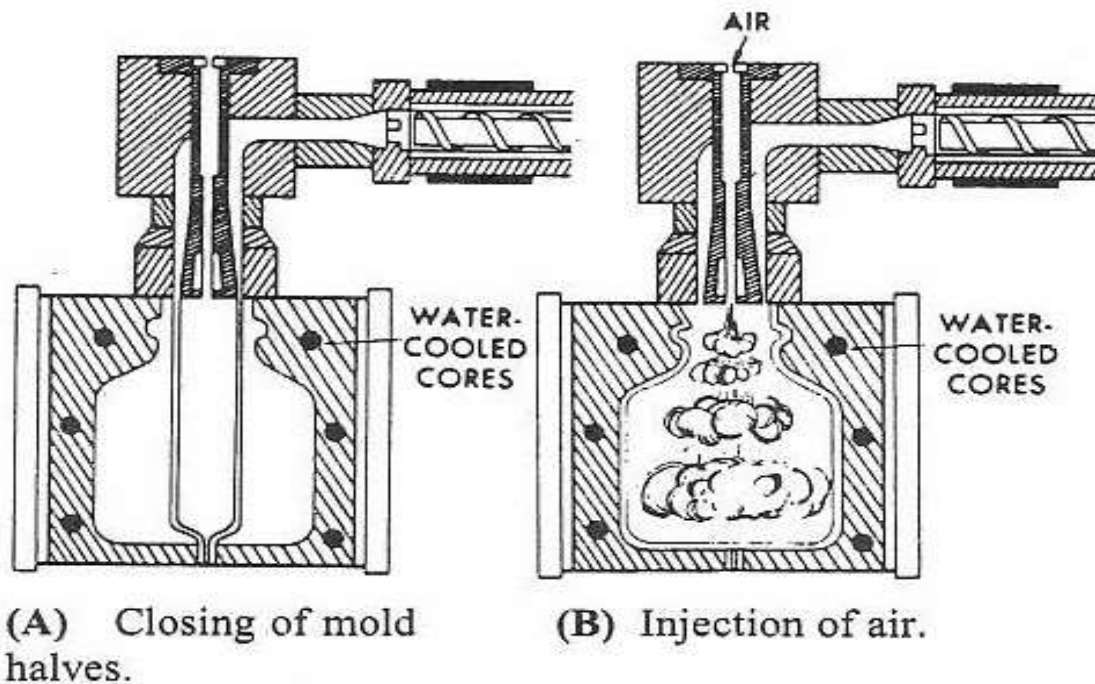
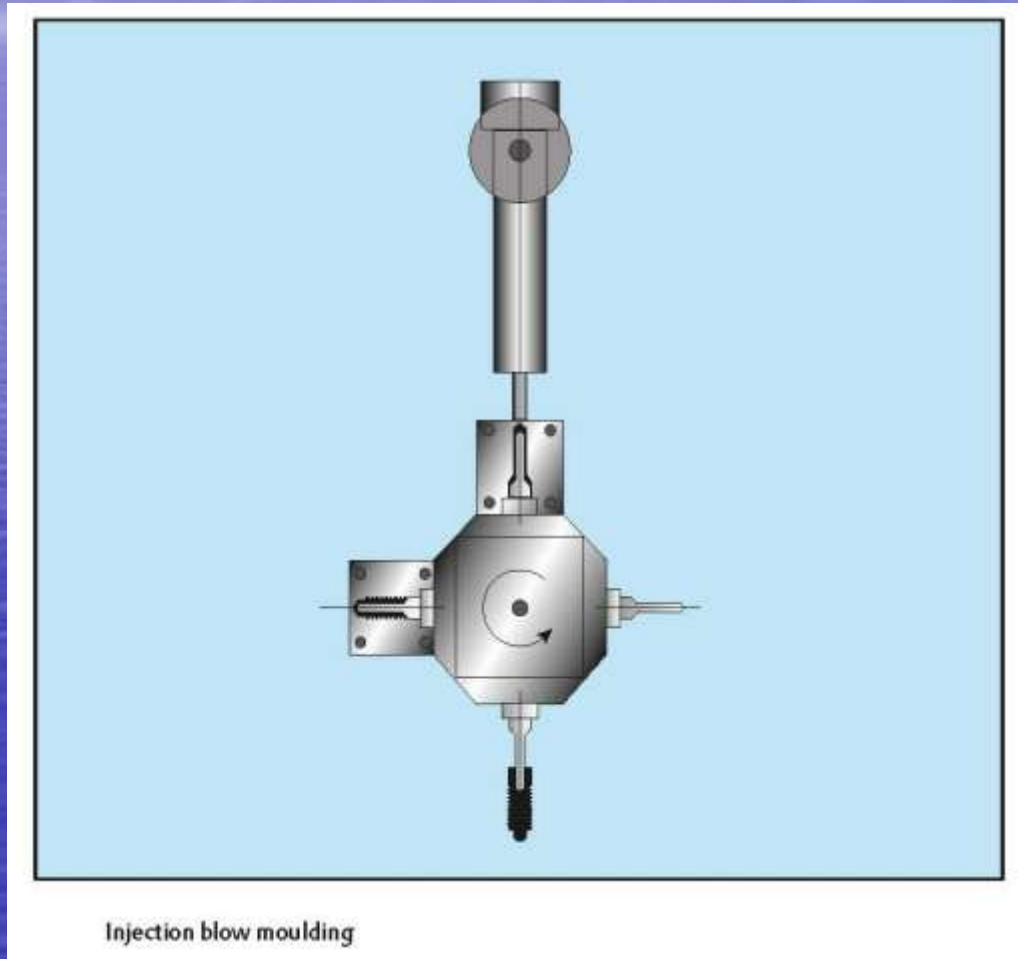
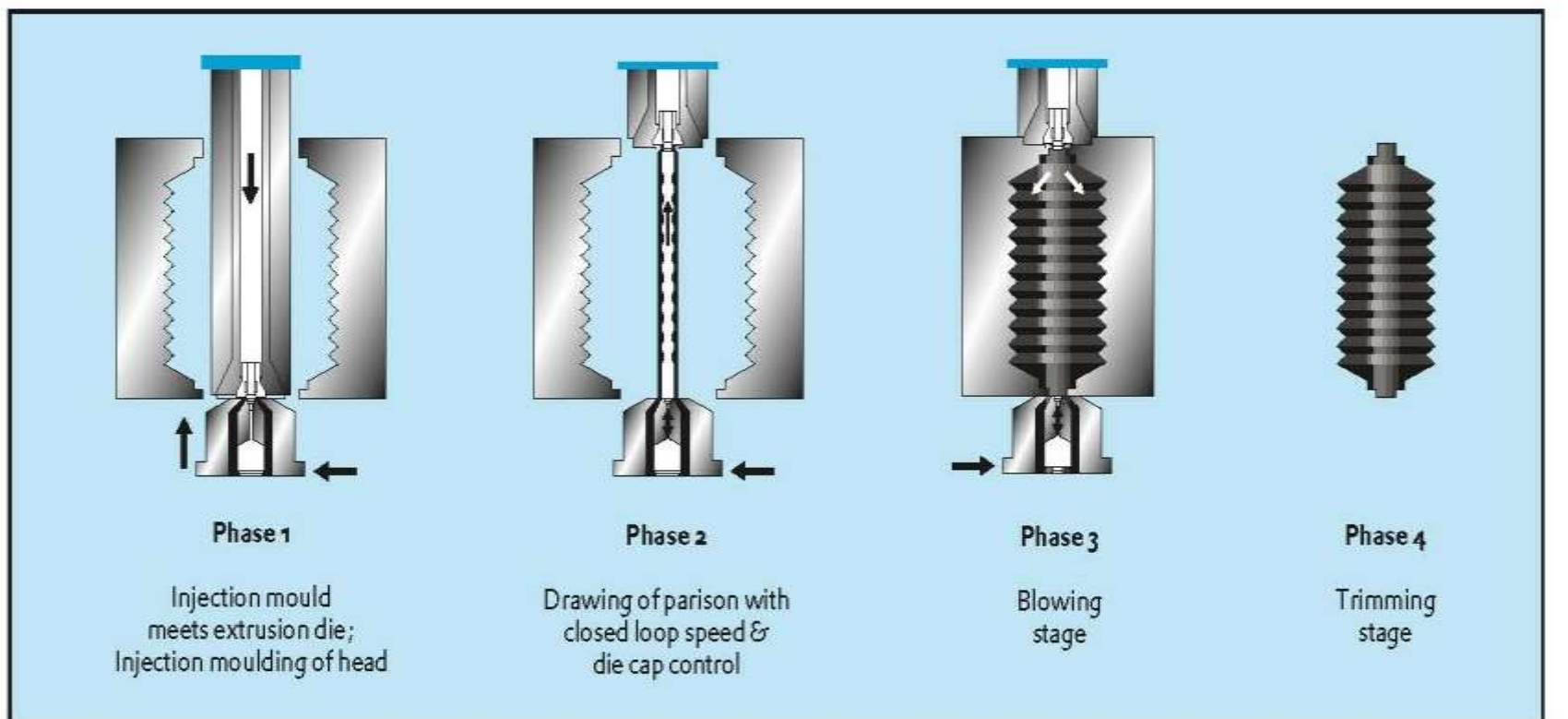

Fig. 11-35. Extrusion blow molding.

INJECTION BLOW MOULDING



PRESS INJECTION BLOW MOULDING



Press injection blow moulding system of Ossberger

EXTRUSION MOULDING

- It is a manufacturing process used to make pipes , hoses , drinking straws curtain tracks, rods, and fibres.
- The machine used to extrude materials is very similar to an injection moulding machine .
- A motor turns a screw which feeds granules of plastic through a heater. The granules melt into a liquid which is forced through a die , forming a long 'tube like' shape.

EXTRUSION MOULDING

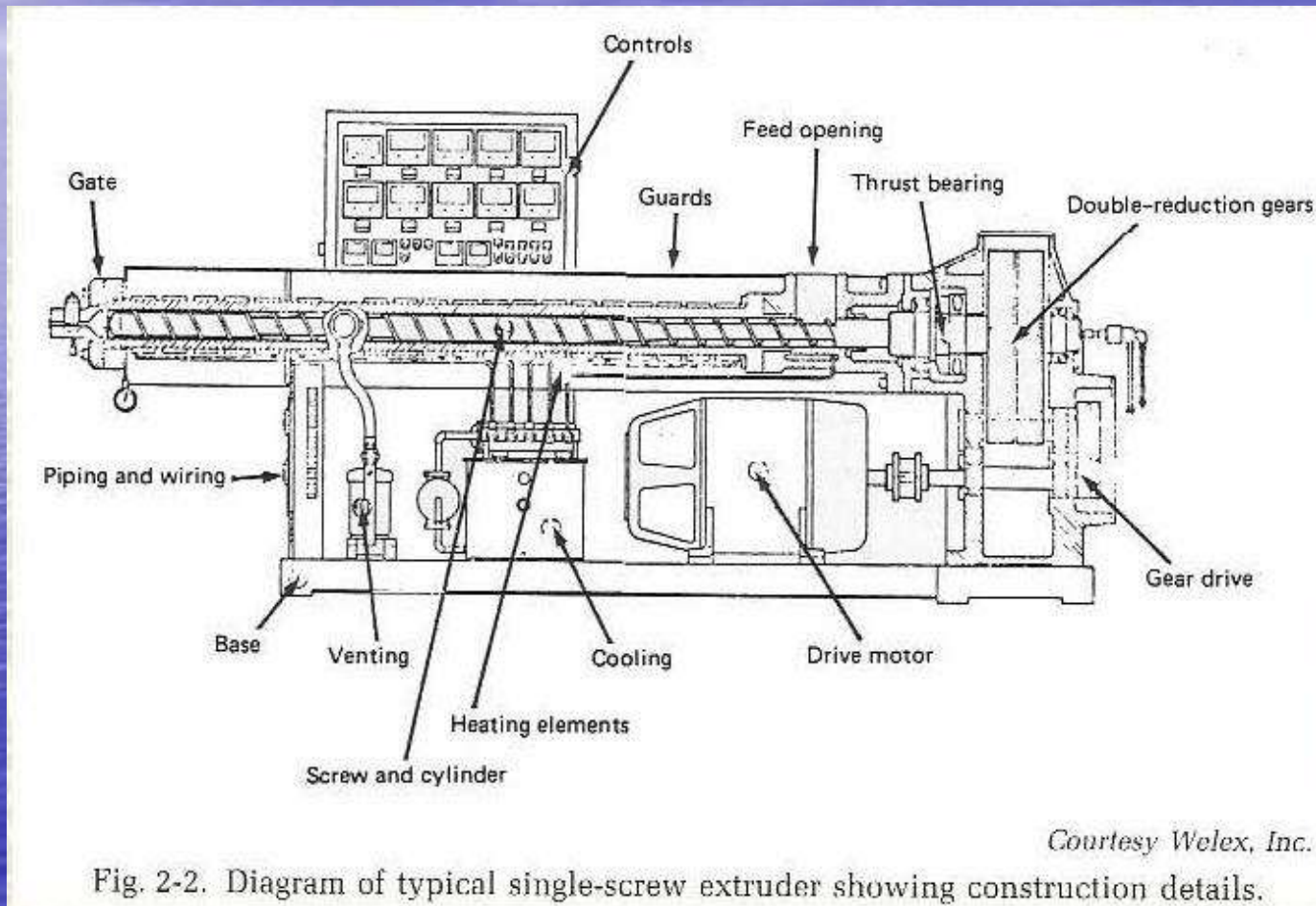

ROTATIONAL MOULDING

- Rotational molding, also known as rotomolding, rotocasting or spin casting etc .
- It is a molding process for creating many kinds of mostly hollow items, typically of plastic .
- A heated hollow mold is filled with a charge or shot weight of material, it is then slowly rotated (usually around two perpendicular axes) causing the softened material to disperse and stick to the walls of the mold .

ROTATIONAL MOULDING

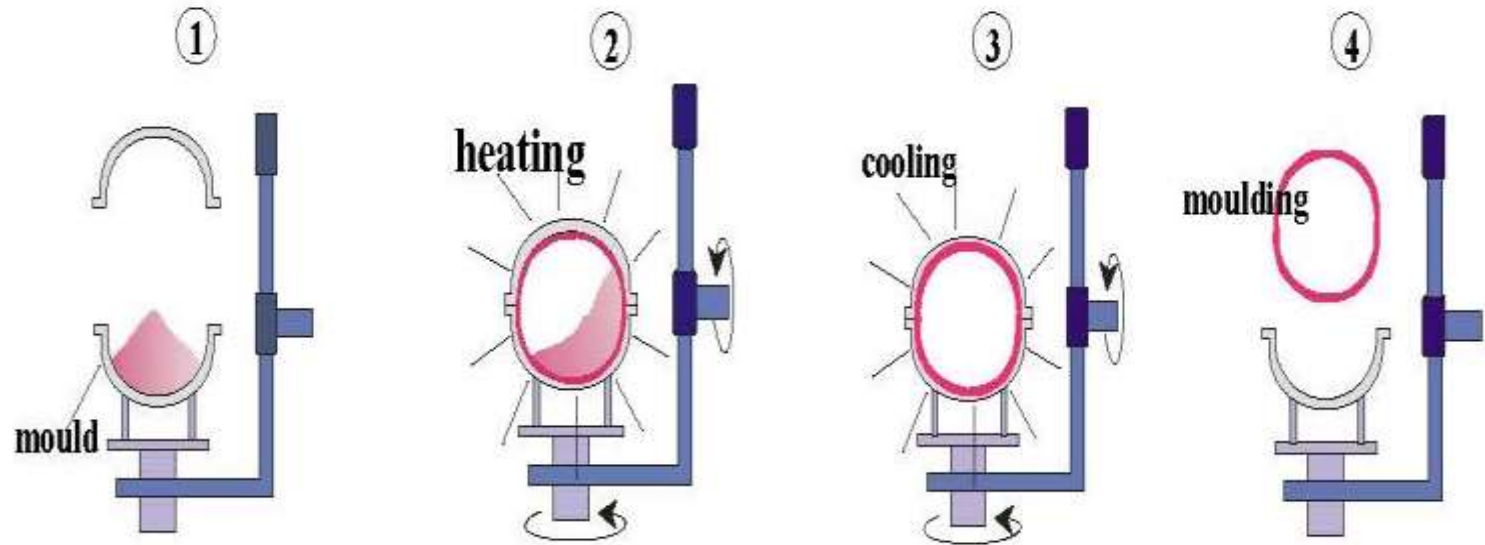
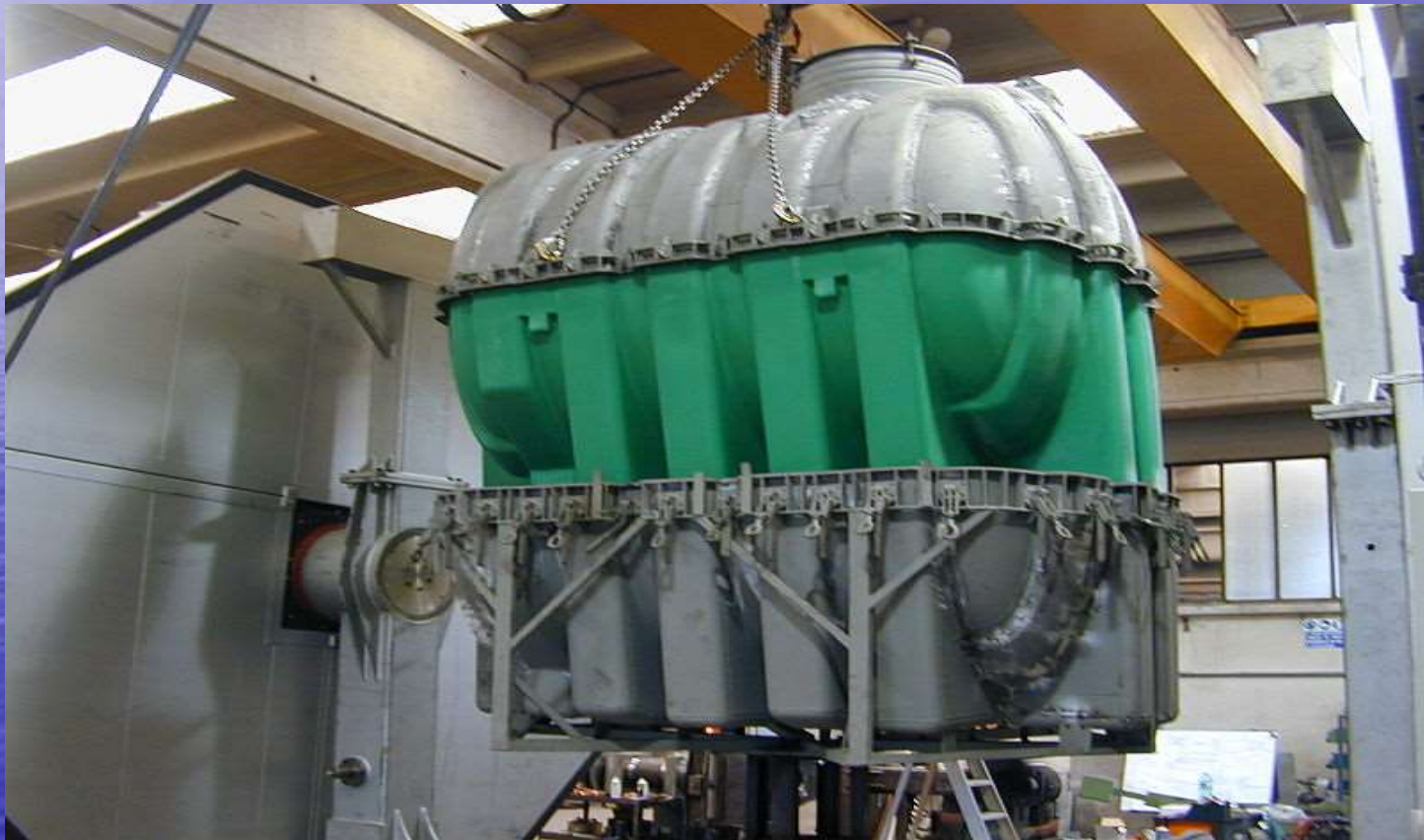

Figure 1. Rotational Moulding process.

ROTATIONAL MOULDING



THERMO FORMING

- Thermoforming is a manufacturing process where a plastic sheet is heated to a pliable forming temperature, formed to a specific shape in a mold, and trimmed to create a usable product.
- The sheet, or "film" when referring to thinner gauges and certain material types, is heated in an oven to a high-enough temperature that it can be stretched into or onto a mold and cooled to a finished shape

Straight Vacuum Forming

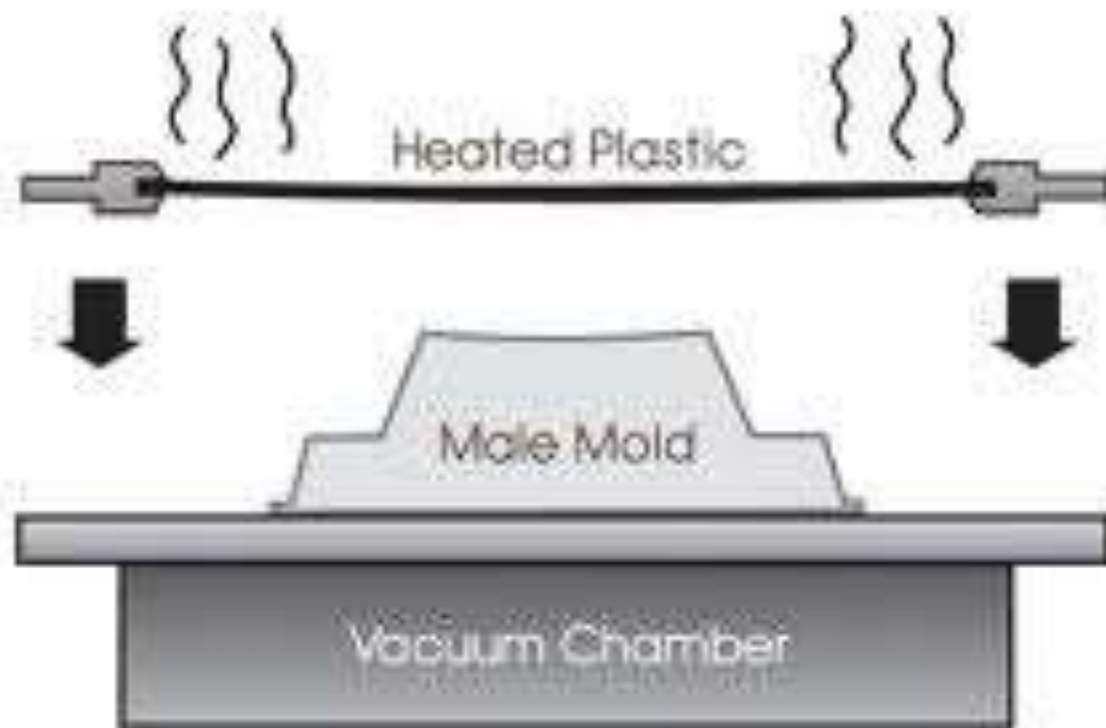

VACCUM/PRESSURE ASSIST THERMOFORMING M/C



THERMOFORMING TOOL FORM

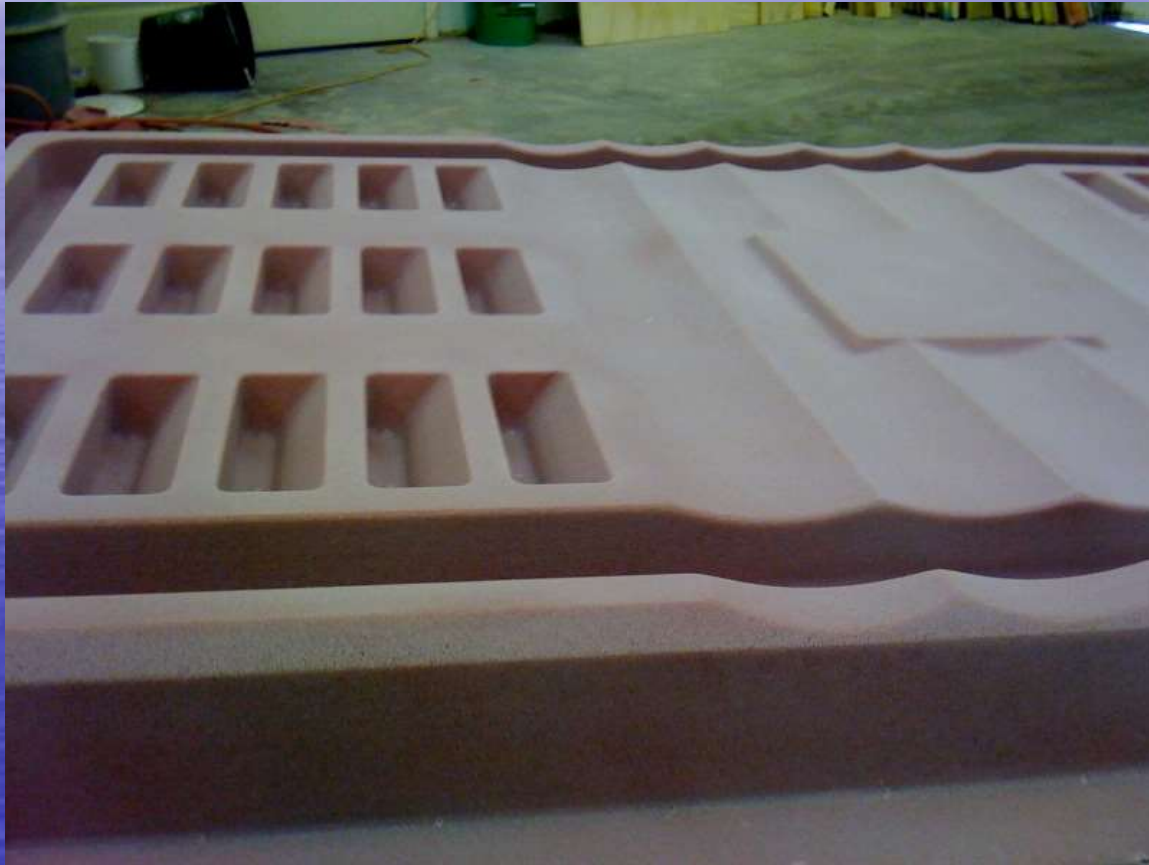

SHRINKAGE

- When a hot plastic cools inside a mould , it contracts by an amount depending on the material being processed and the final product is smaller than the mould size . The contraction is called shrinkage .
- In other words it is the dimensional difference between the mould part and the corresponding impression .

INJECTION MOULD FEATURES

- Injection system.
- Parting line.
- Cooling system.
- Ejection system.
- Core and cavity layout.

INJECTION SYSTEM

- It is necessary to provide a flow way in the injection mould to connect the nozzle of the injection moulding machine to the impression . This is termed as feed system or injection system .
- Normally the feed comprises of runner and gate .

RUNNER

- Runner is a channel designed in to the mould plate to connect sprue with the gate .

VARIOUS TYPES OF RUNNERS

- Depending on the temperature control , different types of runners may be distinguished
 - Standard runner system
 - Hot runner system
 - Cold runner system

STANDARD RUNNER SYSTEM

- Standard runners are directly machined into the mould plates which form the main parting line .
- The temperature is therefore the temperature of the mould .
- This has to be demoulded along with the moulded part after each shot .

HOT RUNNER SYSTEM

- Hot runners may be viewed as extended injection nozzle in the form of a block .
- Heat barriers isolate it from the cold mould .
- The temperature of this block lies in the melting range of the thermoplastic melts .

ADVANTAGES OF HOT RUNNER

- No loss of melt and thus less energy and work input .
- Easier fully automated operation .
- Superior quality because melt can be transferred into the cavity at the optimum sites .

DISADVANTAGES OF HOT RUNNER

- High cost
- The risk of decomposition and production stoppages in the case of material with low thermal resistance .
- Thermal isolation from the hot runner manifold block is problematic .

COLD RUNNER SYSTEM

- Cold runners are used in moulds for reactive materials such as thermoset and rubber .
- The cold runner must be kept at 80-120 degree celcius in order that the material may not react prematurely in the runner .

DISADVANTAGES OF COLD RUNNER SYSTEM

- Pressure consumption in cold runner is very high , a fact which makes the design more expensive .
- Since the slightest temperature difference cause very large difference in viscosity.
- It is practically impossible to fulfill the requirement of introducing the material into every cavity at the same time in the same condition

GATE

- Gate is a channel connecting the runner with the impression .
- It has a small cross sectional area when compared to rest of feed system .

DESIGN OF GATES

- The gate connects the cavity with the runner .
- It should be as small as possible so that material is heated but not damaged by shear
- It must be easy to demould
- It must permit automatic separation of the runners from the moulded parts , without leaving blemishes behind on the part

POSITION OF THE GATE AT THE PART

- The position of the gate determines the direction of the metal flow .
- The gate must always be positioned at the thickest cross section .
- If the gate is not at the thickest section voids and sink marks will be caused .

GATE LOCATION

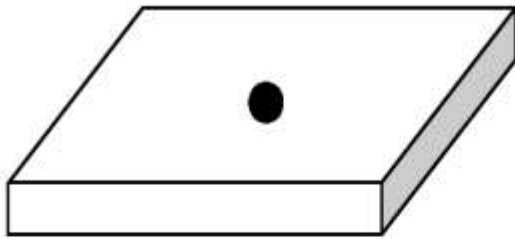

Center gate: radial flow – severe distortion



Diagonal gate: radial flow – twisting

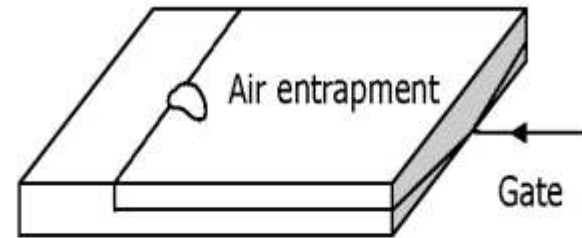

Edge gate: warp free, air entrapment

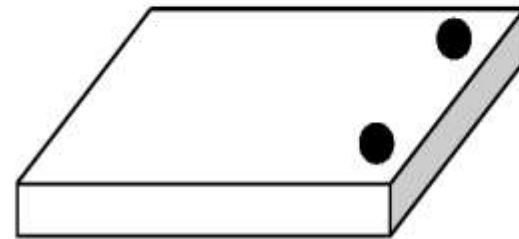

End gates: linear flow – minimum warping

TYPES OF GATES

1. SIDE GATE

- This is the most commonly used gate type and is commonly used for mold structures with 2 or more cavities .
- It is placed at the side of the plastic product. The gate has to be cut manually by a cutter.

SIDE GATE

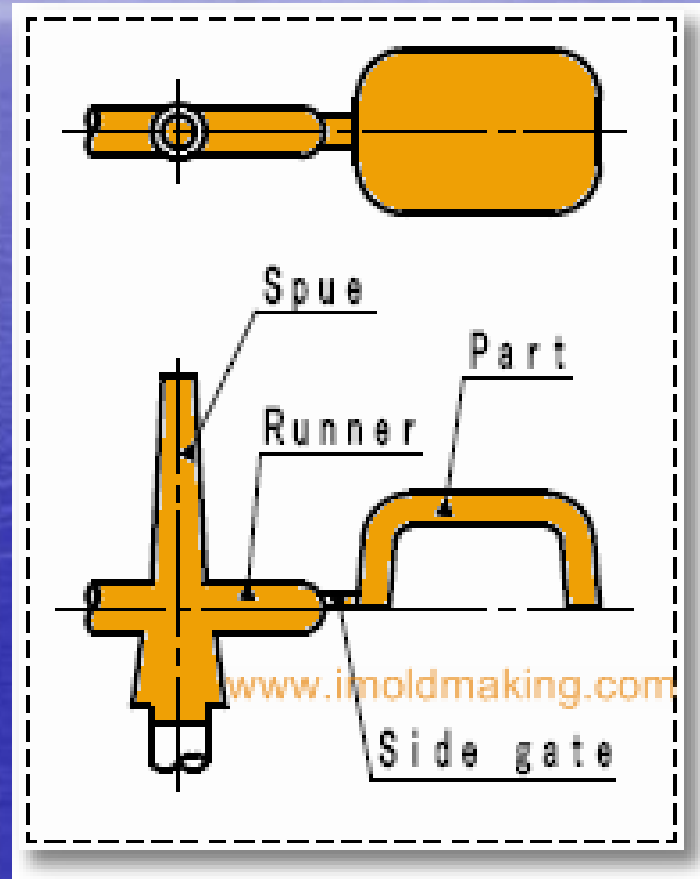

2.SUBMARINE GATE

- The positioning of this gate is flexible throughout the sides of the plastic product.
- It can be placed on the fixed or movable side of the mold but the design has to be thought about carefully so that the product will not be left inside the fixed cavity.
- The gate automatically cuts itself as the mold opens.

SUBMARINE GATE

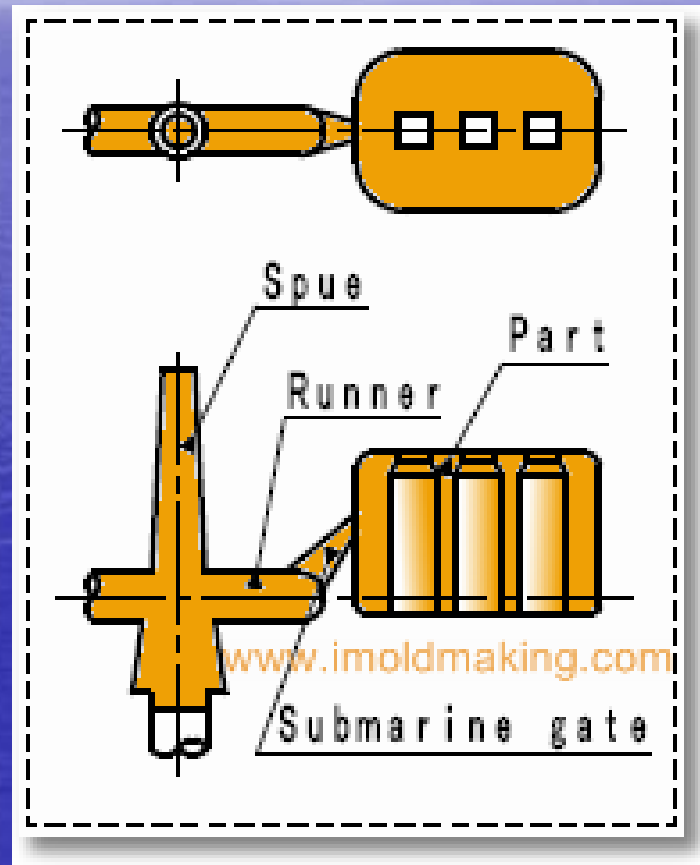

3.FAN GATE

- It is commonly used for large and flat plate products.
- It is placed at the side of the product – same as the side gate.
- The gate has to be cut manually by a cutter.

FAN GATE

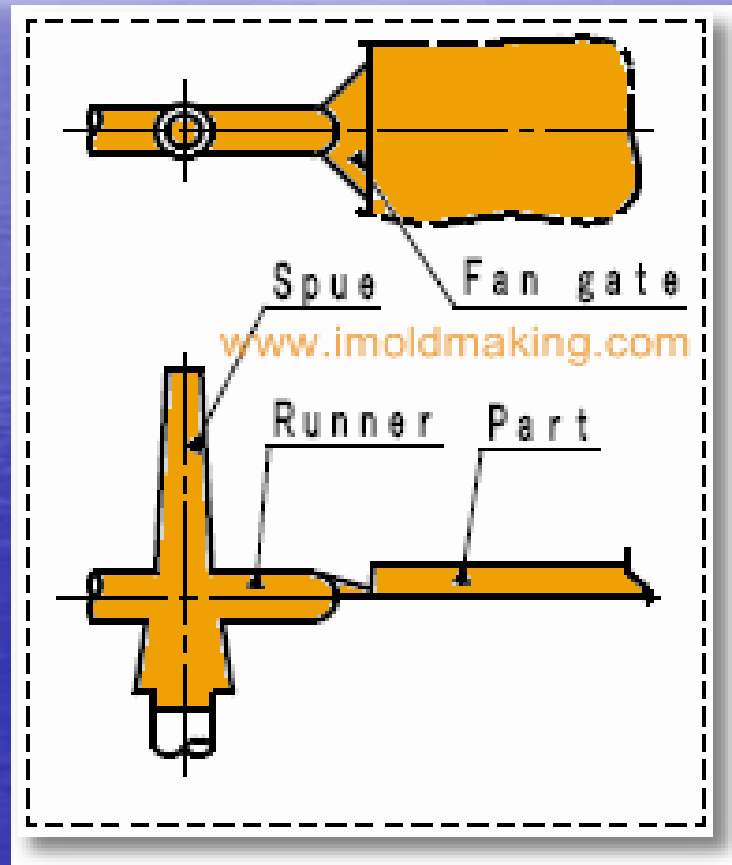

4.FILM GATE

- Similar to fan gate except that it is commonly used for thin and flat plate products .

FILM GATE

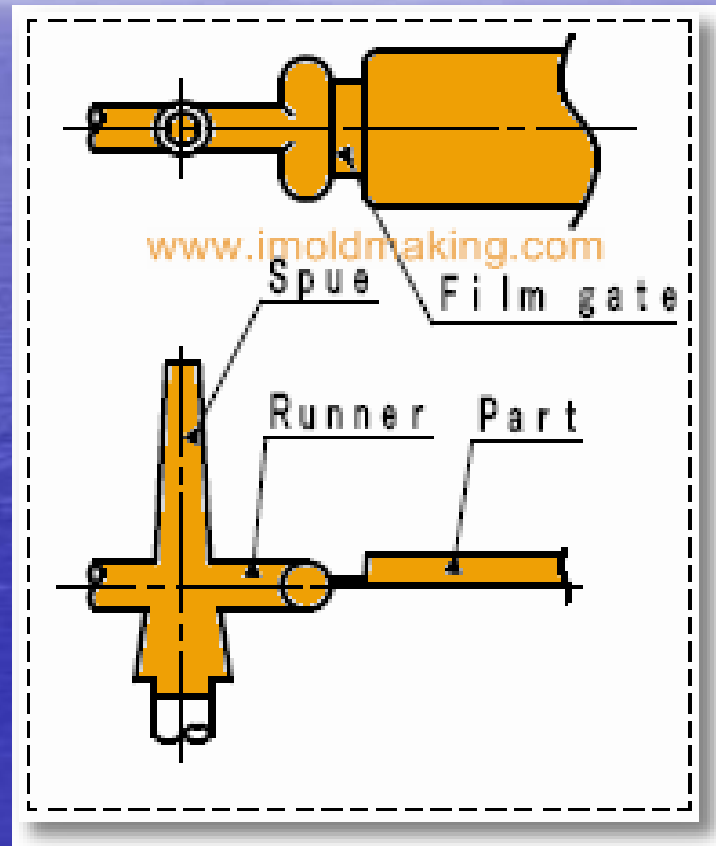

5.PIN GATE

- This is possible for molding multiple cavities or parts.
- The gate positioning is relatively flexible at the top side of the product.
- The runner layout is very flexible as well. The mold base structure is complicated because it uses a 3-plate method.

PIN GATE

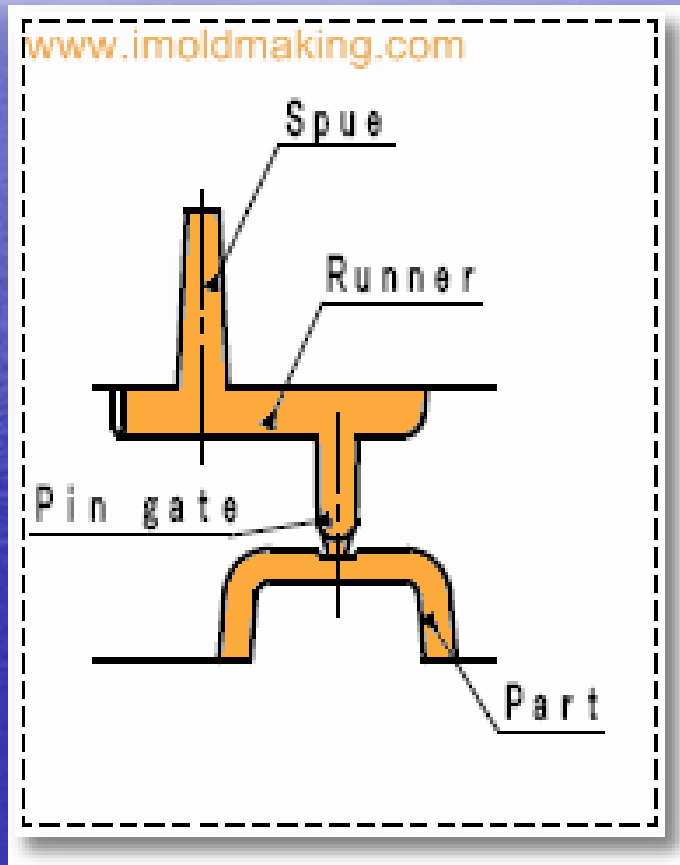

6.BANANA GATE

- This is not a very common gate.
- It is used when the visible surface of the product requires no trace of the gate.
- The gate automatically cuts itself as the mold opens.

BANANA GATE

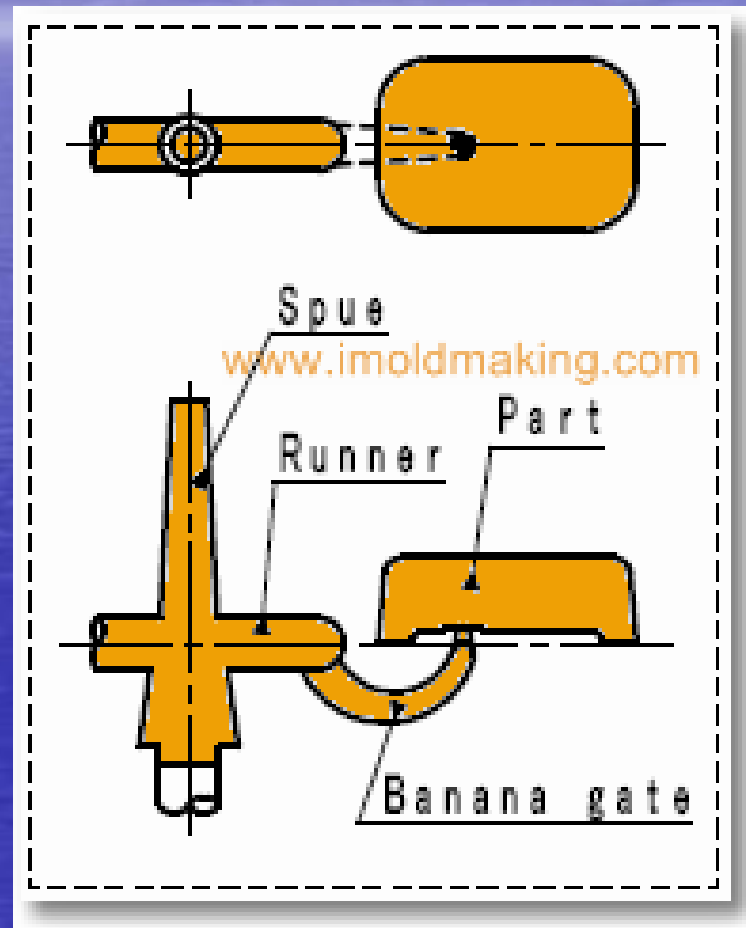

7.DIRECT GATE

- The sprue serves as the gate.
- It is placed on the top side of the product.
- The gate has to be cut manually by a cutter.
- This gate type can only produce one part per shot.
- The injection pressure was reduced due to direct cavity filling.

DIRECT GATE

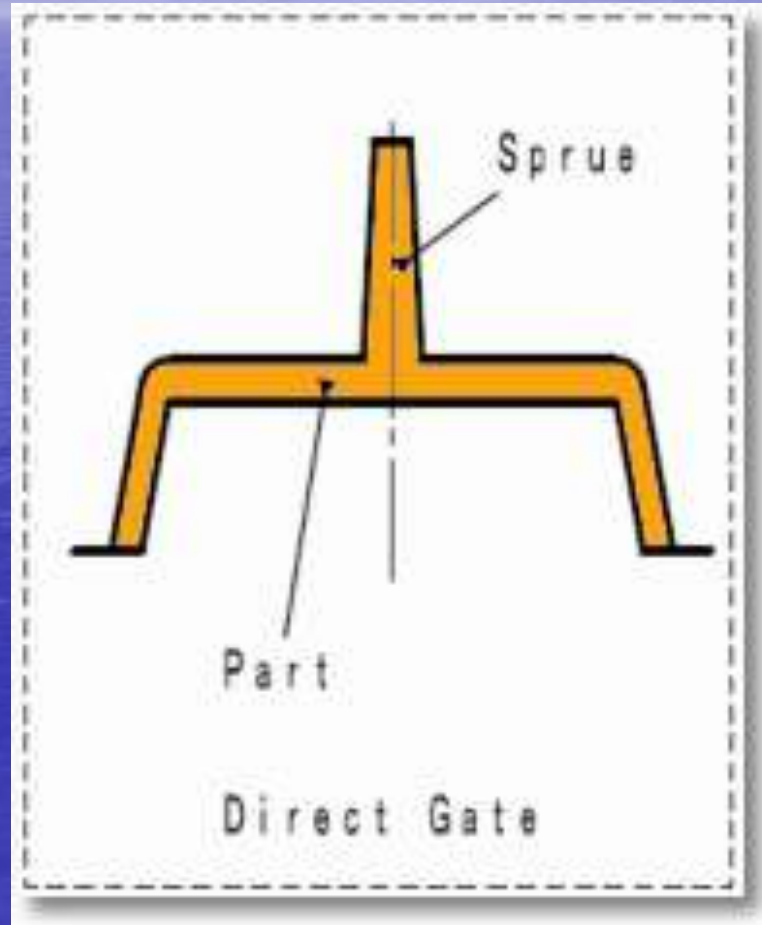

PARTING SURFACE

- The parting surface of the mould are those portion of both mould plates adjacent to the impression which butt together to form a seal and prevent the loss of plastic materials from the impression .
- The parting surface will be provided at the centre of the thickness of the component .

PARTING SURFACE

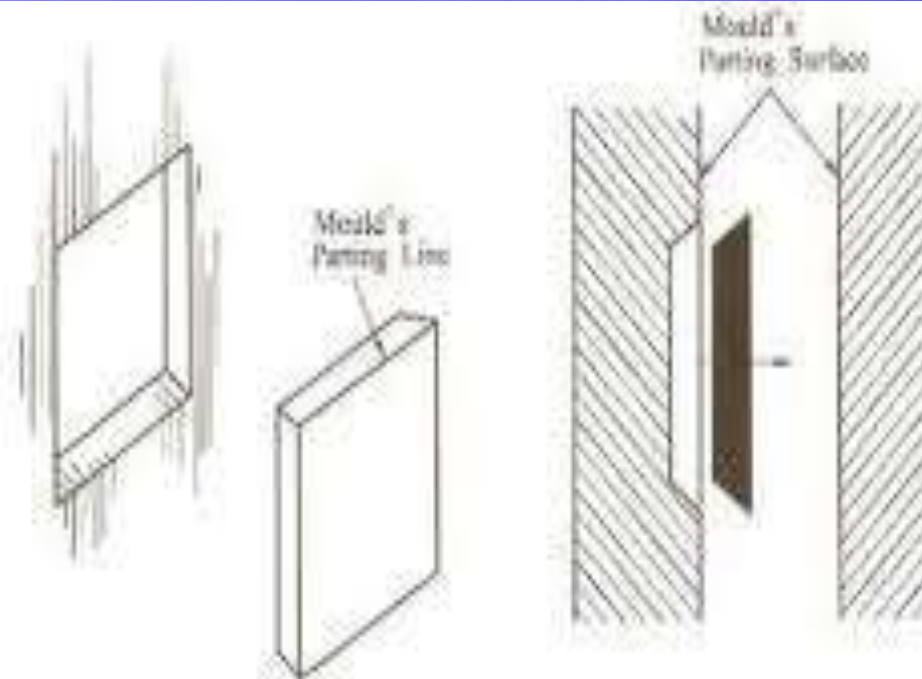

Figure 2.1 Parting line of moulding and parting surface of mould

The position of the parting surface will therefore be at the top of the mould.

EJECTION SYSTEM

- When the moulding material cools , it shrinks by an amount depending on shrinkage of material being processed .
- As the moulding cools it shrinks and stick on the core and for this to be removed , an ejection system is provided .

DETERMINATION OF MOULD SIZE

- The size of the mould depends primarily on the size of the machine .
- Frequently an existing machine or a certain machine size poses an important limitation , to which the design engineers has to submit .
- Such limitations are ,

- Shot size , the amount of melt that can be conveyed into the mould with one stroke of the screw or plunger .
- Plasticizing rate , the amount of plasticated material the machine can provide per unit time .
- Clamping force , which has to compensate the reactive force from maximum internal cavity pressure .
- Maximum area of machine platen given by the distance between tie bars

MAXIMUM NUMBER OF CAVITIES

- At first the maximum theoretical number of cavities is calculated .

$$N1 = \frac{\text{max. shot size } S_v \text{ in cm}^3}{\text{volume of part and runner } M_v \text{ in cm}^3}$$

- This computation assumes utilization of the whole maximum shot size of the machine computed from screw diameter and displacement .

CLAMPING FORCE

- The minimum clamping force is derived from the reactive force of the cavity , which results from the projected area of all cavities and runners and the maximum cavity pressure .

- $F = A \cdot P$

here , F – Reactive force

A – Projected areas of cavities and runner system

p – The cavity pressure .

MOULD COOLING

- Mould cooling serves to dissipate the heat of the molding quickly and uniformly
- Fast cooling is necessary to obtain economical production and uniform cooling is required for product quality.
- Optimal properties of engineering plastics can be achieved only when the right mold temperature is set and maintained during processing.

The mold temperature has a substantial effect on

- Mechanical properties
- Shrinkage behavior
- Warpage
- Surface quality
- Cycle time
- Flow length in thin walled parts

COOLING SYSTEM IN MOULD

