

Living Environment Systems

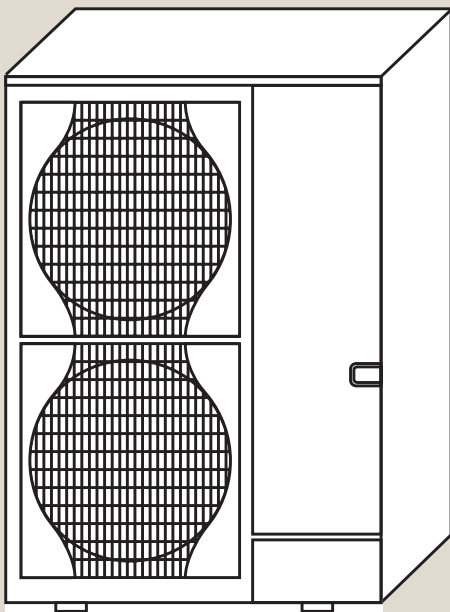

Mr. Slim

Required safety measures for R32 systems

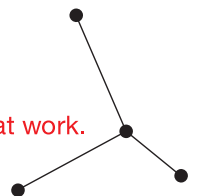

Contents

1.	General information	02
2.	Classification of installation areas	03
2.1	Outdoor installation	03
2.2	Installation in occupied areas	04
2.3	Installation in a separate machine room	04
3.	Components containing refrigerant in occupied areas	05
3.1	Determining the safety zone	05
3.2	Safety measures	08
3.2.1	Ventilation (natural or mechanical)	08
3.2.2	Safety stop valves	10
3.2.3	Safety alarm unit	11
4.	Flowchart checklist	12
4.1	Components containing refrigerant in occupied areas	12
5.	Installation examples (recommendations)	14
5.1	Installation of indoor units	14
5.2	Installation of pipes	20

1. General information

SAFETY GUIDELINES ACCORDING TO IEC 60335

When using R32 refrigerant, it is necessary to take additional measures into account in the planning and installation of air conditioning systems, heat pumps and ventilation systems. As a refrigerant belonging to safety class A2L, R32 is rated 'mildly flammable'. The guidelines according to IEC 60335-2-40 and DIN EN 378 must be observed in order to guarantee the safety of persons within buildings. IEC 60335-2-40 explicitly addresses the safety of air conditioning units, heat pumps and room dehumidifiers for domestic use and similar purposes. DIN EN 378 defines requirements for general chillers and the classification of installation areas.



NOTE!

As this manual is only a summary of relevant content from DIN EN 378 and IEC 60335, it does not guarantee compliance with any particular standards. It provides information and recommendations that are intended to assist in the implementation of R32 projects. Special cases must always be evaluated on an individual basis.

The IEC 60335 and DIN EN 378 standards contain stipulations relating to safety and environmental requirements for chillers and heat pumps. Unit safety, various aspects of occupational safety and matters of construction law provide the basis for this content. Key topics include the installation areas of the units, the limit values of refrigerants and the protection of persons based on the latest technology.



NOTE!

When integrating A2L air conditioning systems into air handling units, the components containing refrigerant and the ventilation system itself must be assessed on the basis of safety-related measures and equipped accordingly. A separate document (design manual PAC-IF) is available for such applications.

Refrigerant safety classes		
Flammability	Toxicity	
	Non-toxic	Toxic
Highly flammable	A3	B3
Flammable	A2	B2
Mildly flammable	A2L (R32)	B2L
Non-combustible	A1 (R410A)	B1



NOTE!

Pipes that contain flammable gases and are located in escape routes or stairways must be made entirely from non-flammable materials (including their insulation).



WARNING!

Do not use any resources other than those recommended by the manufacturer for the purpose of cleaning or speeding up the defrosting process.

- ▶ The refrigerant must be stored in a room without any permanently operated sources of ignition (e.g. naked flames or gas appliances and electric heaters in operation).
- ▶ Do not puncture or ignite.
- ▶ Bear in mind that refrigerant may be odourless.

2. Classification of installation areas

2.1 Outdoor installation

The requirements for classification of outdoor installations are defined in the standard DIN EN 378.

In the case of outdoor installation, components containing refrigerant are installed in a room in which at least one of the longer walls is open to the outside. This also includes ventilation slots to the outside that cover an area (A) amounting to at least 75% of the outside walls (see Fig. 1).

REQUIREMENTS

- If unit components are to be installed in an outdoor location in which released refrigerant may accumulate (e.g. a recess; see Fig. 2), the requirements relating to gas detection systems and the ventilation of machine rooms must be met (see 'Refrigerating equipment located inside a machinery room'; DIN EN 378-3 Section 4.3). It must be guaranteed that refrigerant cannot accumulate in large quantities. Refrigerant detectors and fans may help remedy any such issues.
- Units containing more than 10 kg of R32 refrigerant must feature a clearly visible label to this effect (usually attached to the unit at the factory). They must also feature a sign stating that smoking, naked flames and other potential sources of ignition must be avoided.
- Unit components installed outdoors must be arranged such that no refrigerant can leak into the building or pose a risk to persons or property in any other way. As a result, they should never be installed in the vicinity of fresh-air vents, doorways, trapdoors or similar openings.



NOTE!

If all components containing refrigerant are located outdoors or in a machine room, the refrigerant charge quantity is not subject to any stipulated limit.

Exception: units in which refrigerants from safety group A2L are used and that are connected via an air duct system to one or more rooms (further information available in design manual PAC-IF).

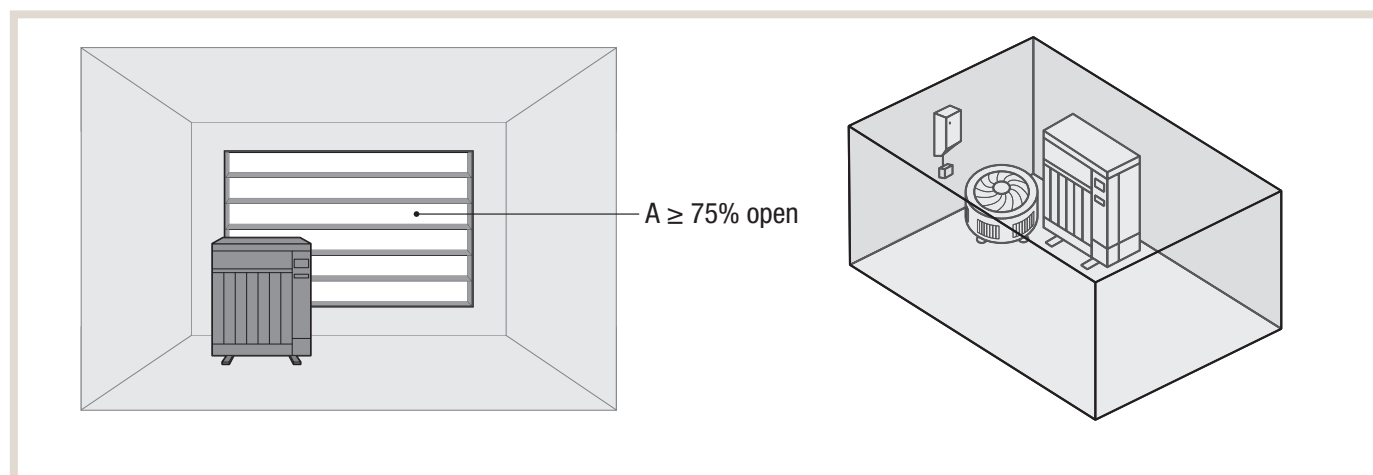

Fig. 1: Opened wall

Fig. 2: Location featuring potential accumulation of refrigerant

2.2 Installation in occupied areas

This classification applies when unit components containing refrigerant are located in an area that is restricted by walls, floors and ceilings and in which persons remain present for an extended period of time. If surrounding areas are clearly and permanently open to the occupied area in question, then they may be considered a constituent part of this occupied area. Permissible openings include unhinged doors, open passages and other permanent openings that extend down to the floor (max. 100 mm above the floor) and guarantee natural convection (see chapter 3.2.1).



NOTE!

The exact framework conditions for identifying a permissible opening between two neighbouring rooms are stated in IEC 60335 Section GG.1.3.

In the event that components containing refrigerant are to be installed in an occupied area, the guidelines stated in IEC 60335 Annex GG must be met.

The requirements that must be met in relation to the installation area are determined on the basis of the refrigerant charge quantity and the size of the room.

The maximum possible refrigerant charge quantity for the application described here is limited to **63.84 kg** (depending on the number of indoor units).

Max. refrigerant charge quantity	
Number of indoor units	Max. refrigerant charge quantity [kg]
1	15.96
2	31.92
3	47.88
4 or more	63.84

2.3 Installation in a separate machine room

This classification applies when components containing refrigerant are located in a fully-enclosed room or enclosure that is only accessible to authorised persons and is used for the installation of parts of the chiller. A machine room may contain additional components provided that the installation requirements are compatible with the chiller safety requirements.



CAUTION!

If all components containing refrigerant are located in a machine room or outdoors, the refrigerant charge quantity is not subject to any stipulated limit.

Exception: units in which refrigerants from safety group A2L are used and that are connected via an air duct system to one or more rooms not identified as machine rooms (e.g. ventilation station; see design manual PAC-IF).

If a machine room is used for A2L air conditioning units or heat pumps, this must be equipped in accordance with special safety standards. The requirements are defined in DIN EN 378-3 (Section 5) and are not covered in any further detail within this brochure.



NOTE!

More detailed information on installations and required safety measures in machine rooms is available on request.

3. Components containing refrigerant in occupied areas

3.1 Determining the safety zone

The required safety measures concerning the installation of components containing refrigerant in occupied areas are governed primarily by the ratio of the refrigerant charge quantity to the volume of the smallest affected room. The standard provides various limit values for this purpose, which dictate the type and number of additional safety measures to be implemented.



NOTE!

Note the maximum area and height of a room when calculating the volume.

- ▶ It is not permitted to exceed a maximum area of 250 m² and a height of 2.2 m when calculating the volume, even if the dimensions of the room itself are larger.
-

The following figures feature the individual limit values and safety zones based on the room volume and refrigerant charge quantity in occupied areas.



NOTE!

Note the different limits.

- ▶ Within the area that does not require risk management, the limits vary according to the installation height of the unit.
-

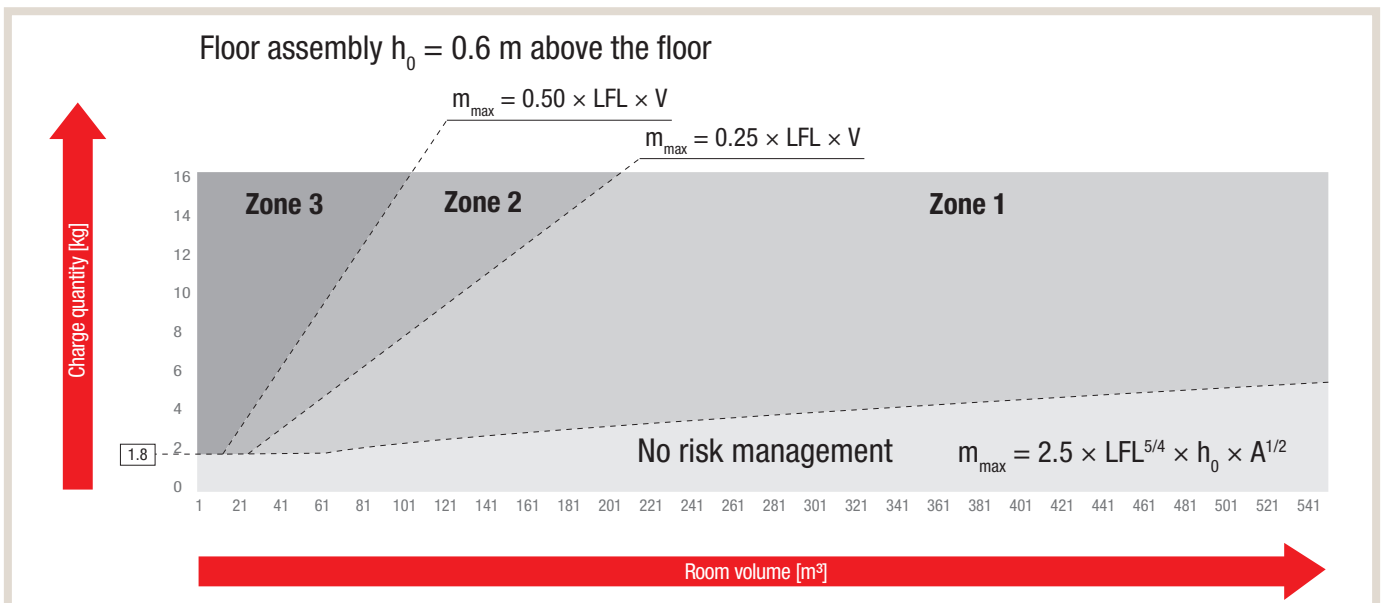
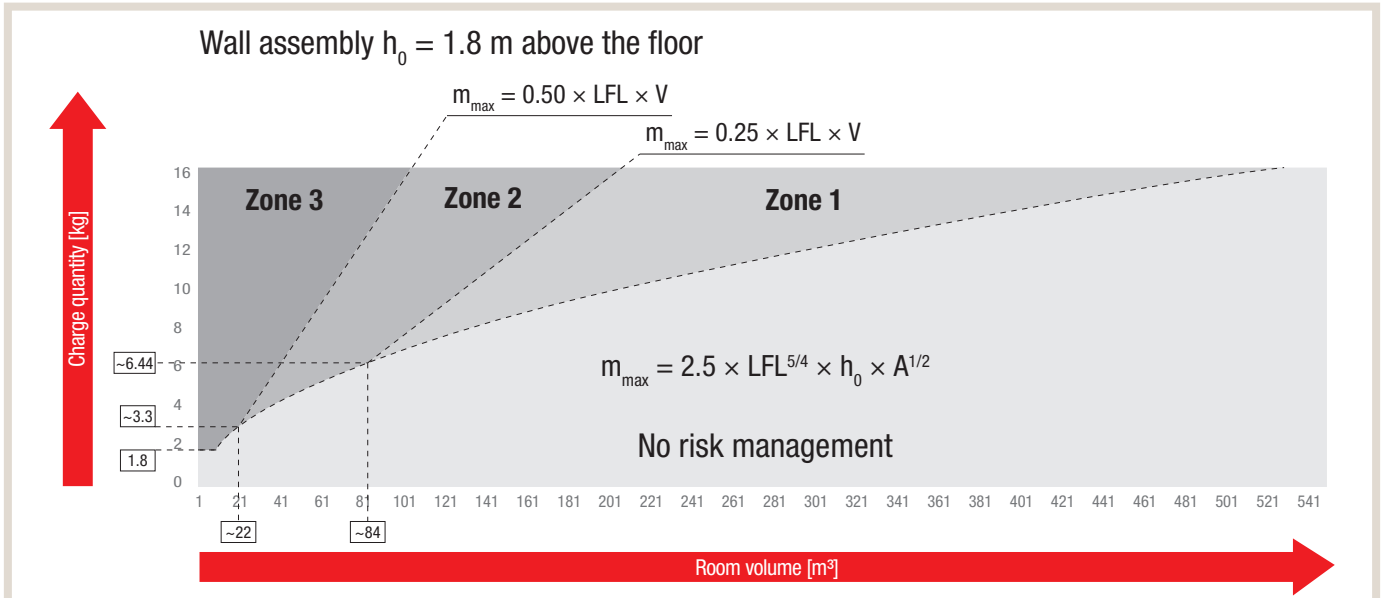
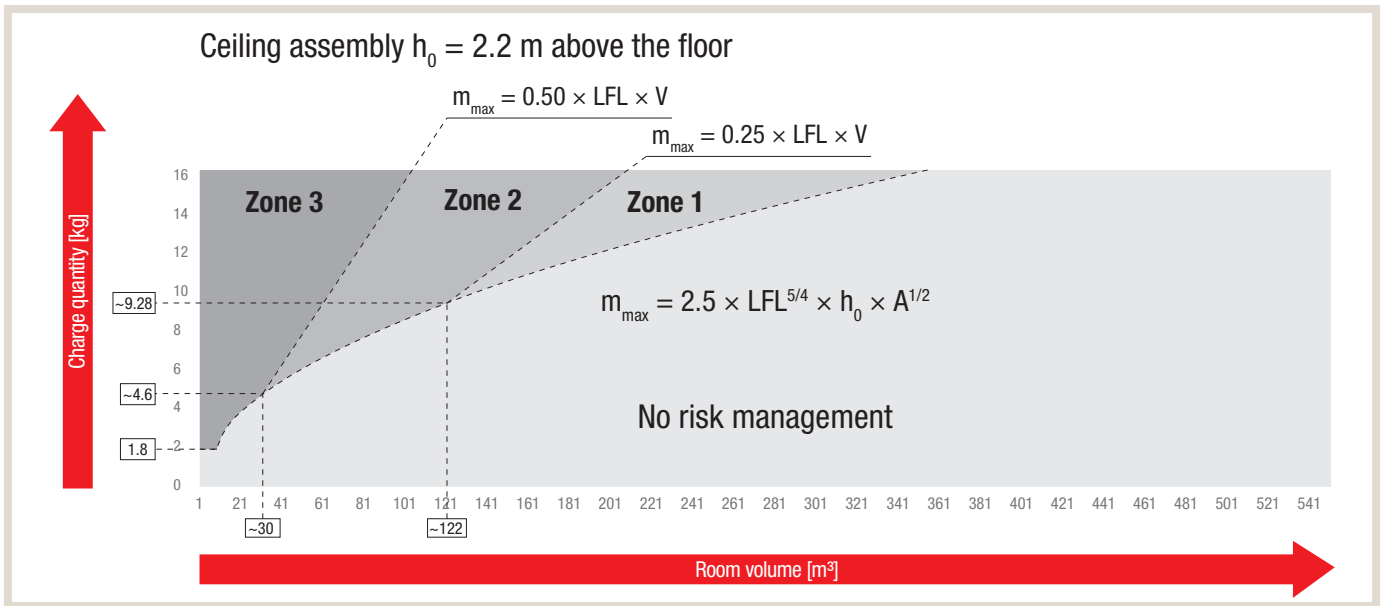

The following tables demonstrate how the corresponding zone is calculated and list the safety measures that are to be implemented there.

Determining the safety zone and defining the required measures

No risk management			
Zone	Limit value	Calculation	Required safety measures
No risk management		Charge quantity ≤ 1.8 kg or $m_{\max} = 2.5 \times \text{LFL}^{5/4} \times h_0 \times A^{1/2}$ <ul style="list-style-type: none"> Max. 15.96 kg 	No safety measures required

Risk management

In order to enable the options of additional risk management, the unit must meet the following requirements (according to IEC 60335-2-40 Section 22.125):

- The outdoor unit must be located outside the occupied area in question (e.g. installation outdoors or in machine room).
- Only solder connections are permitted (exception: direct connection between refrigerant pipe and indoor unit) – mechanically produced solder adapters are recommended.
- Pipes must be protected against accidental damage.

Zone	Limit value	Calculation	Required safety measures
1	$0.25 \times \text{LFL} \times V$	$m_{\max} < 0.0768 \text{ kg/m}^3 \times V$ <ul style="list-style-type: none"> Max. 63.84 kg 	No safety precautions required
2	$0.50 \times \text{LFL} \times V$	$m_{\max} < 0.154 \text{ kg/m}^3 \times V$ <ul style="list-style-type: none"> Max. 63.84 kg 	At least one safety measure (ventilation, stop valves or alarm) must be fulfilled. In the case of installations on the lowest basement floor, at least two safety measures are required.
3		$m_{\max} > 0.154 \text{ kg/m}^3 \times V$ <ul style="list-style-type: none"> Max. 63.84 kg 	At least two safety measures (ventilation, stop valves or alarm) must be fulfilled. Installations on the lowest basement floor are not permitted.

Legend:

m_{\max} = total refrigerant charge quantity of largest circuit [kg] (pre-charge quantity + post-charge quantity)

A = room area [m^2] (max. 250 m^2)

V = room volume [m^3]

h_0 = installation height [m] (ceiling assembly = 2.2 m; wall assembly = 1.8 m; floor assembly = 0.6 m)

H = room height (max. 2.2 m)

LFL = lower explosion limit (R32 = 0.307 [kg/m^3])

QLMV = quantity limit with minimum ventilation

RCL = refrigerant concentration limit

QLAV = quantity limit with additional ventilation



CAUTION!

When components containing refrigerant are installed below 1.8 m, a mechanical circulation unit must be included in order to prevent stagnation (accumulation of refrigerant). This unit must be in permanent operation or activated via a refrigerant detector. The minimum air throughput is 240 m^3/h and the air speed must be between 0.86 and 7.08 m/s (depending on installation height and blow-out angle).

- This only applies to safety zones 1, 2 and 3.

3.2 Safety measures

This section addresses the possible safety measures for risk management.

3.2.1 Ventilation (natural or mechanical)

NATURAL VENTILATION

- Rarefaction opening to a larger room with a sufficient volume for ensuring that the maximum refrigerant concentration in the event of a leak is $< 0.0768 \text{ kg/m}^3$.
- In order to enable air circulation, there must be two openings to the neighbouring room.

Requirements for the lower opening:

- The total area (A_{\min}) of the lower opening must be at least 0.12 m^2 (for R32).
- The minimum height of the opening is 20 mm.
- Openings that are located more than 300 mm above the floor must not be included when calculating the minimum area A_{\min} .
- At least 50% of the required area A_{\min} must be less than 200 mm above the floor.
- The bottom edge of the opening must be located no more than 100 mm above the floor.

Requirements for the upper opening:

- The total area of the upper opening must correspond to at least 50% of A_{\min} (0.06 m^2).
- The bottom edge of the opening must be located at least 1.5 m above the floor.
- The minimum height of the opening is 20 mm.

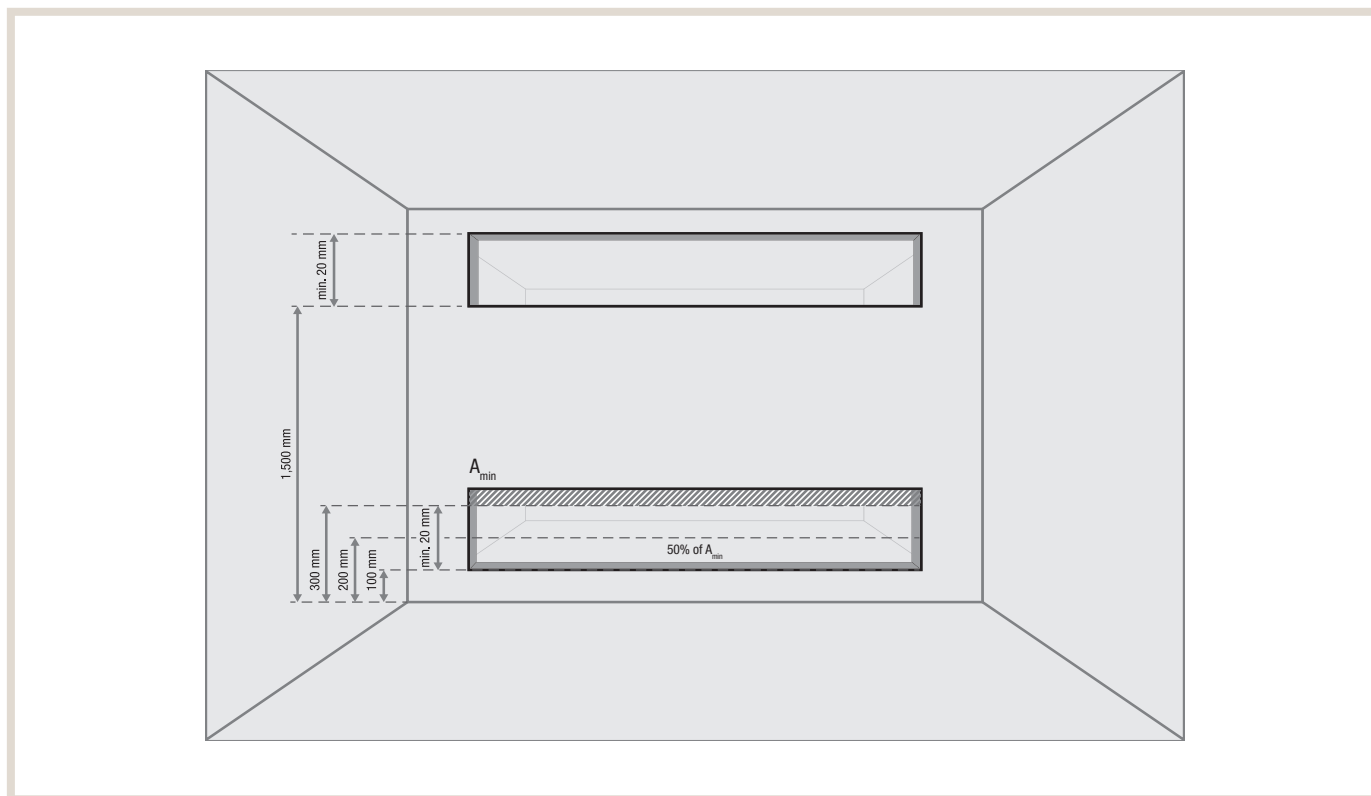

CAUTION!

- ▶ Rarefaction openings to the outside are not permitted.
- ▶ The openings must be permanent; as such, it must not be possible to seal them.

MECHANICAL VENTILATION (RECOMMENDED)

- Air routing either to the outside or to a neighbouring room with a sufficient volume for ensuring that the maximum refrigerant concentration in the event of a leak is $< 0.0768 \text{ kg/m}^3$.
- The ventilation must either be in permanent operation or activated via a refrigerant detector (according to IEC 60335 Section GG.11.3).
- Required air flow (Q) = $130.29 \text{ m}^3/\text{h}$ (pressure losses via ducts must be taken into account).
- When the refrigerant detector is triggered, the compressor in the air conditioning system should additionally be switched off so as to reduce the leakage rate to a minimum.
- The fault status must be maintained for a period of 5 minutes after a reset has been carried out.

**NOTE!**

- ▶ Ensure that the air intake features sufficient dimensions.
- ▶ Air outlet openings must be positioned close to the floor (max. 100 mm above the floor in the case of floor installation).
- ▶ Ensure sufficient clearance between installed air intake and outlet openings (avoid air short-circuit).

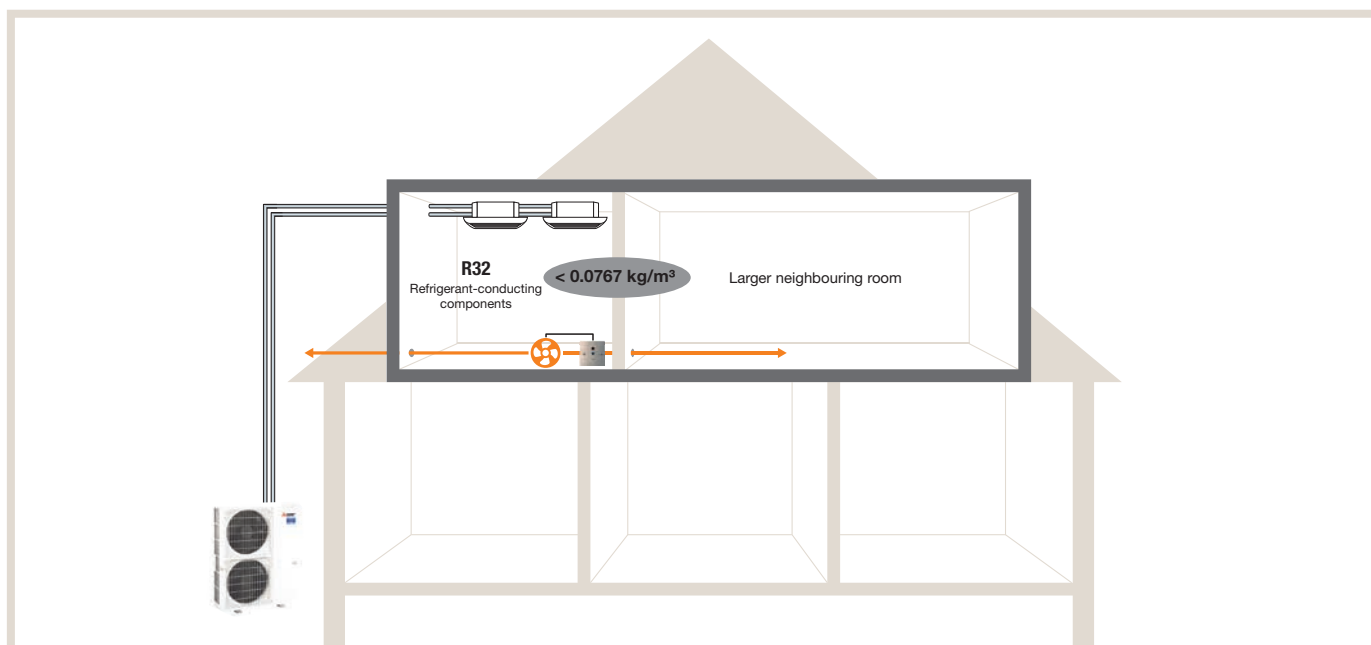

3.2.2 Safety stop valves

- The stop valves must be located outside the building or in a room with a sufficiently large volume so as to avoid exceeding 0.0768 kg/m^3 .
- Valves must be controlled via a refrigerant detector (according to IEC 60335 Section GG.12).
- Valves must close automatically in event of power failure.

**NOTE!**

- ▶ Determine how much refrigerant can penetrate into the room after shutting off. This value must be below 0.15 kg/m^3 and documented in the installation documents (see IEC 60335, GG.12).

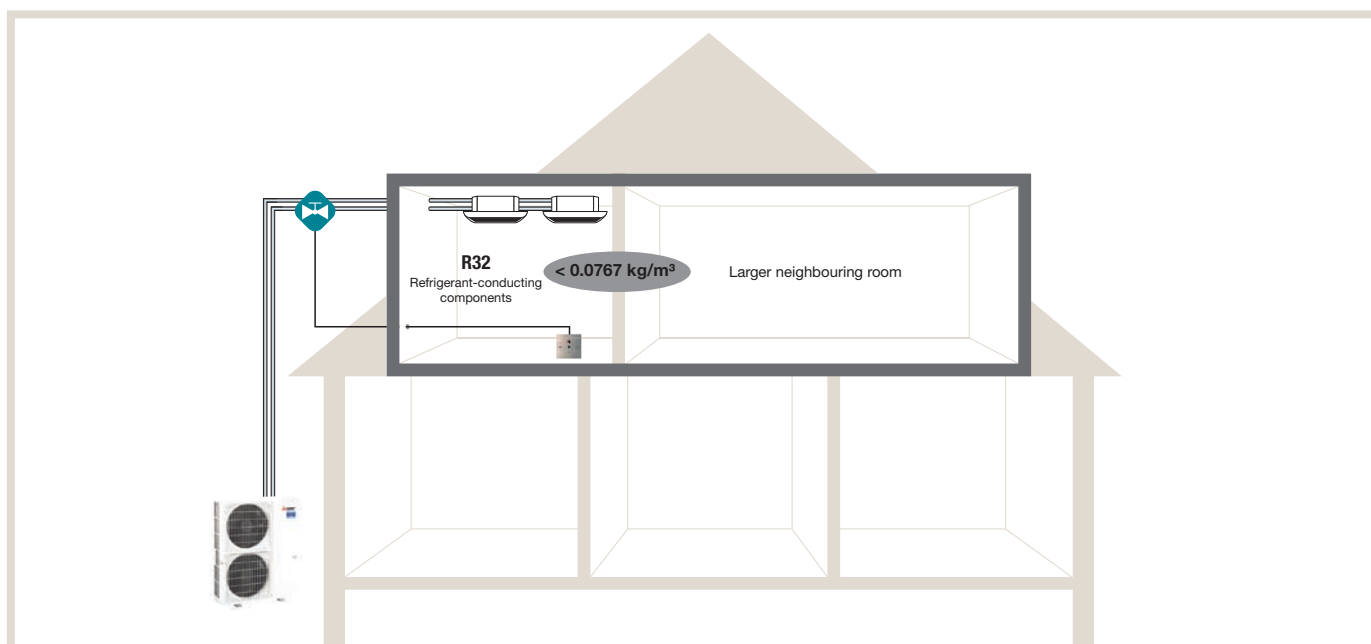

3.2.3 Safety alarm unit

- Alarm must be activated via a refrigerant detector (according to IEC 60335 Section GG.13).
- Within the room at least, the alarm system must provide a visual (e.g. flashing light) and audible warning signal (e.g. sirens at 15 dB above background noise level).
- An independent power supply is required.
- An authorised person (e.g. technician) must be alerted automatically in order to initiate further measures.
- According to IEC 60335 Section GG.13, a warning is required at a location with 24-hour monitoring if any of the following points apply to the room in question:
 - Sleeping facilities are provided (e.g. hotel rooms)
 - Persons are restricted in their movements (e.g. retirement homes)
 - The number of persons present is not regulated
 - Access is open to persons who are not familiar with the required safety precautions

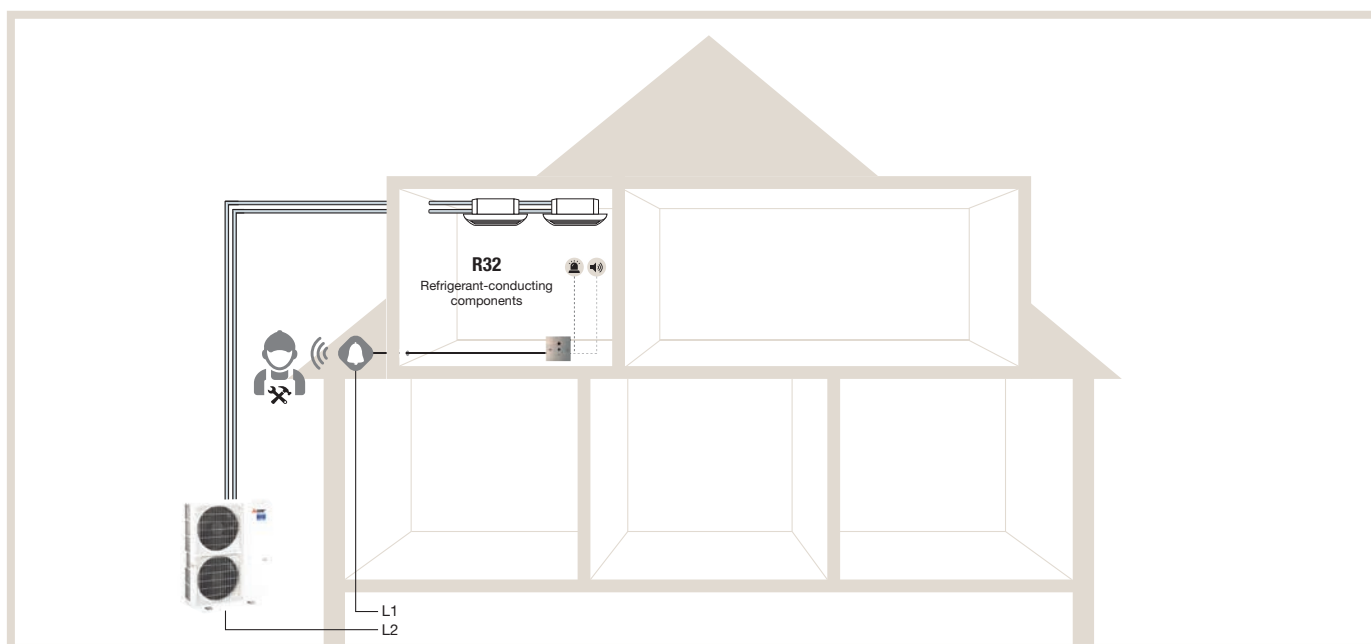

4. Flowchart checklist

4.1 Components containing refrigerant in occupied areas

When installing small output levels, it is first necessary to check whether extended measures are required at all. Units with a refrigerant charge of under 15.96 kg may be used in this category under certain circumstances.

No special requirements

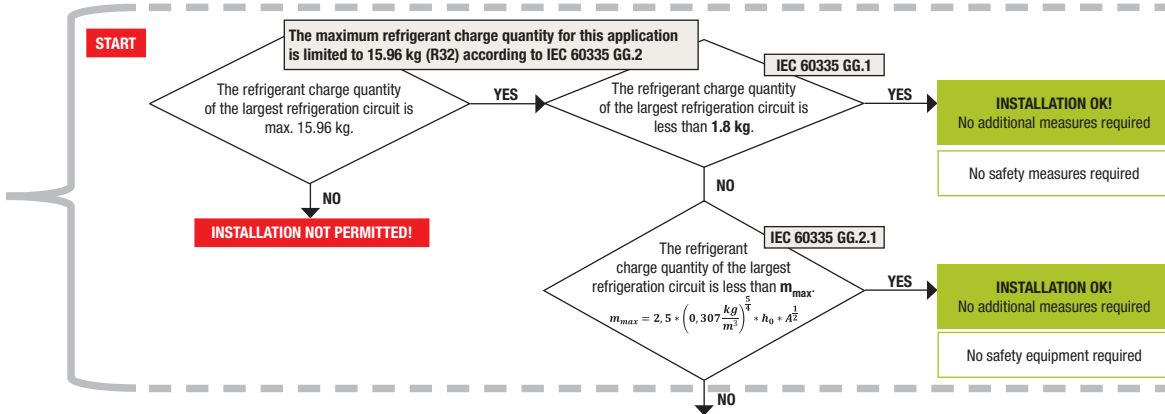

In order for the following flowchart to be applicable, the unit must meet the requirements for 'Chillers with increased density' (according to 22.125; IEC 60335).

Additional risk management

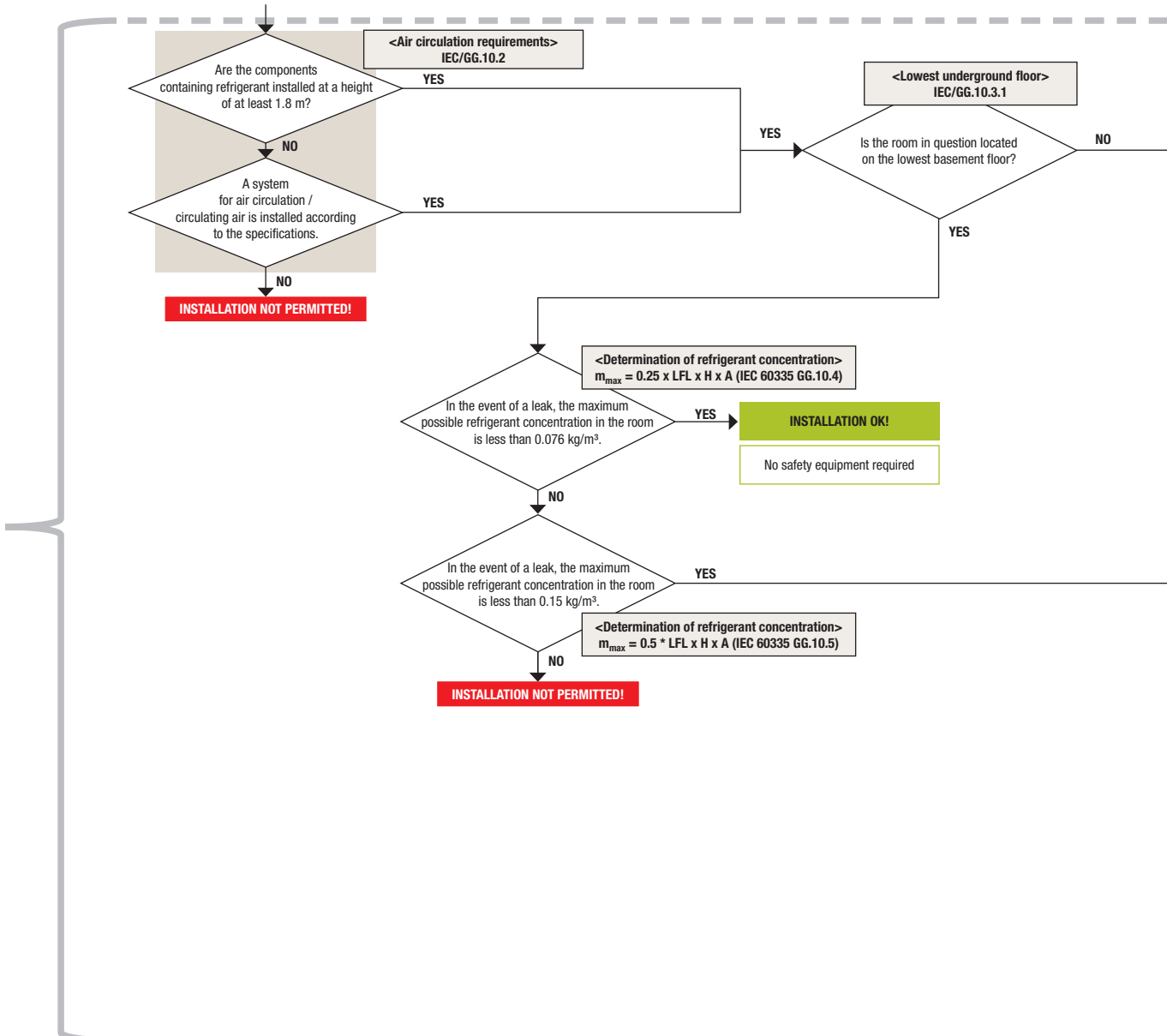

Ceiling assembly $h_0 = 2.2$ m above the floor

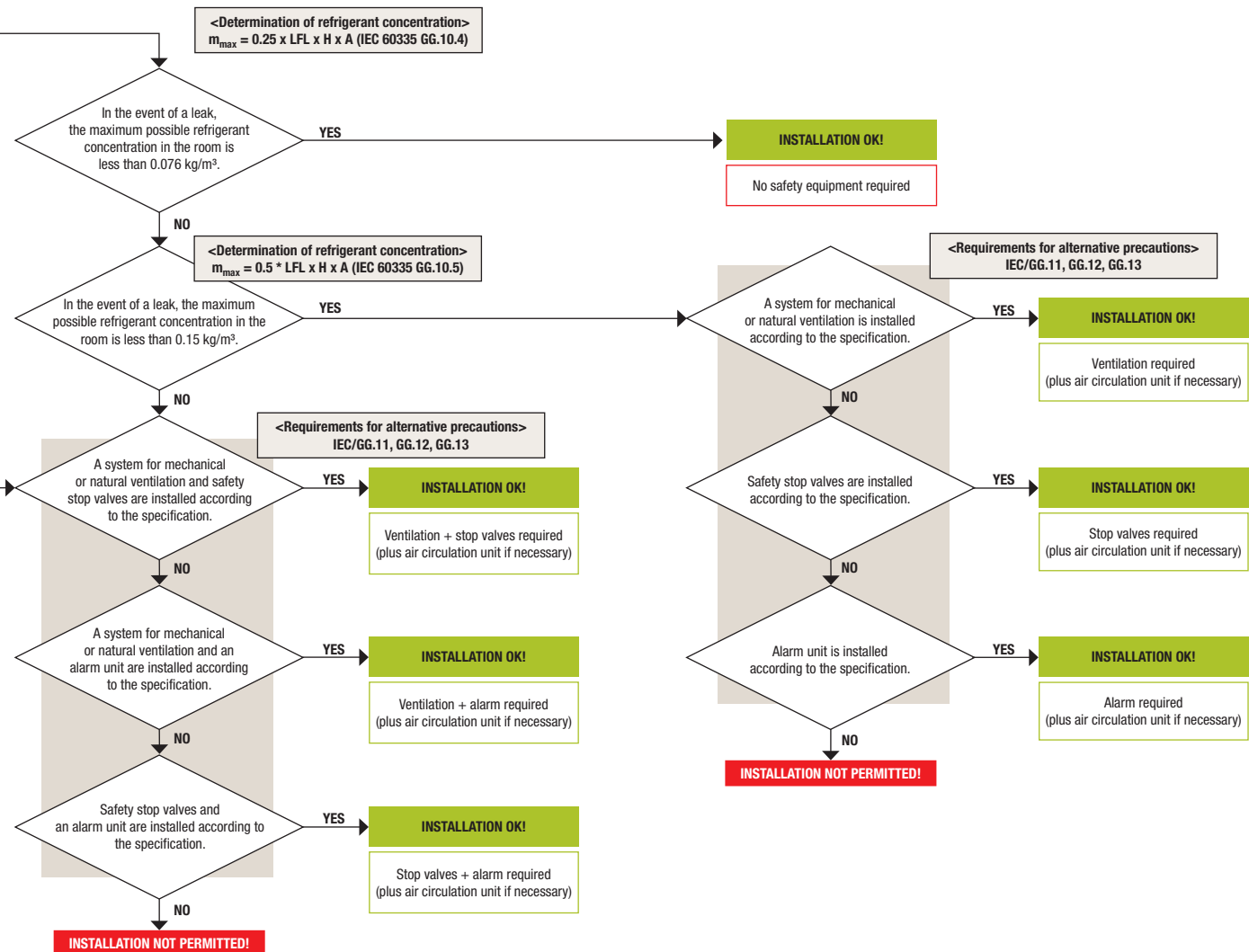
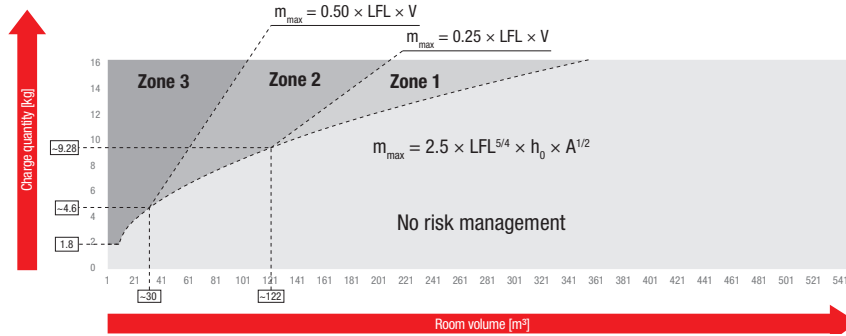

5. Installation examples (recommendations)

5.1 Installation of indoor units

Installation in zone 1 above 1.8 m

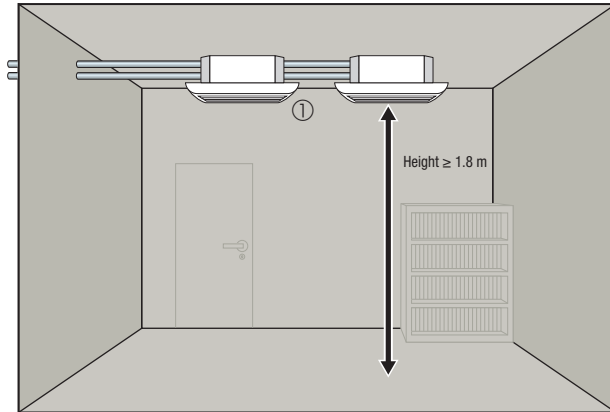

Safety measures:

- None

Legend:

- ① Indoor unit

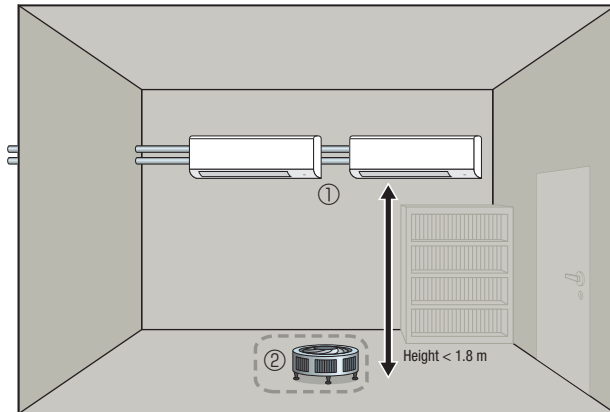
Installation in zone 1 below 1.8 m**Safety measures:**

- Air circulation (permanent operation or controlled via refrigerant detector)

Legend:

- ① Indoor unit
- ② Air circulation

Installation in zone 2 above 1.8 m

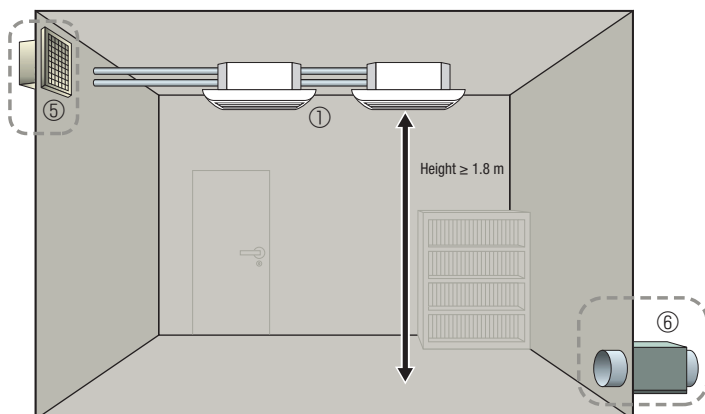

Safety measures:

- Mechanical ventilation (permanent operation or activated via refrigerant detector)

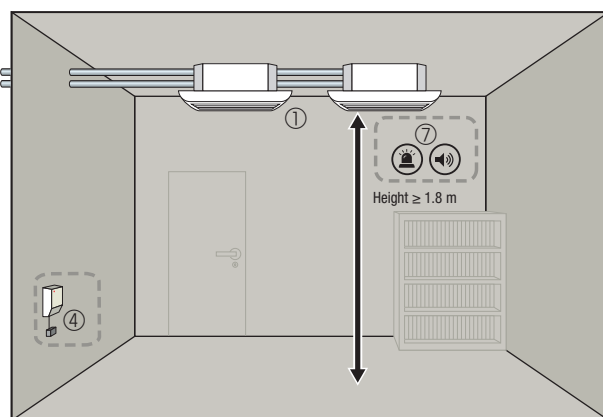

Safety measures:

- Safety alarm unit (controlled via refrigerant detector)

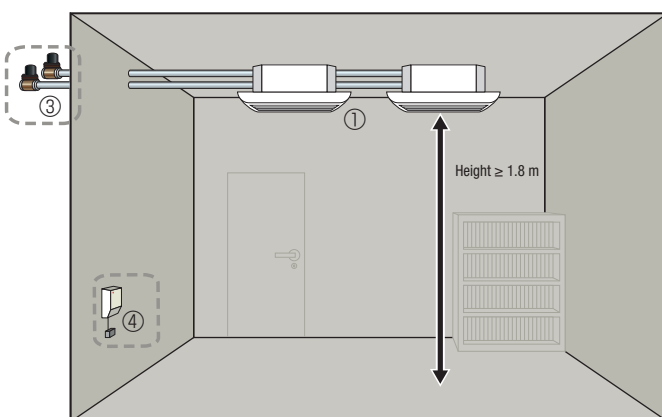

Safety measures:

- Safety stop valves (controlled via refrigerant detector)

Legend:

- ① Indoor unit
- ③ Stop valve
- ④ Refrigerant detector

- ⑤ Air intake
- ⑥ Mechanical ventilation
- ⑦ Alarm system (acoustic and visual alarm)

- ⑧ Authorised person (e.g. technician)
- ⑨ Poss. monitored location (e.g. retirement home)

Installation in zone 2 below 1.8 m

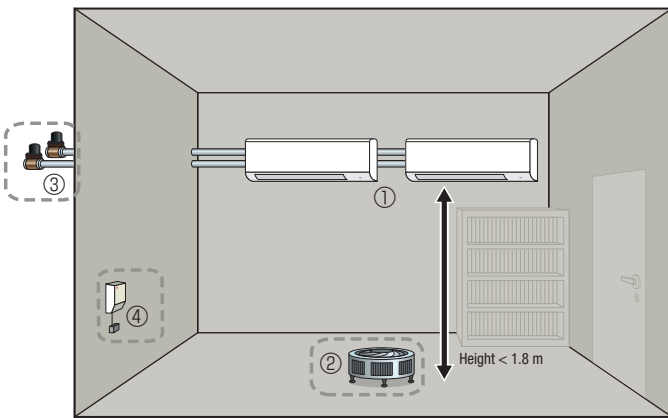

Safety measures:

- Air circulation (permanent operation or controlled via refrigerant detector)
- Safety stop valves (activated via refrigerant detector)

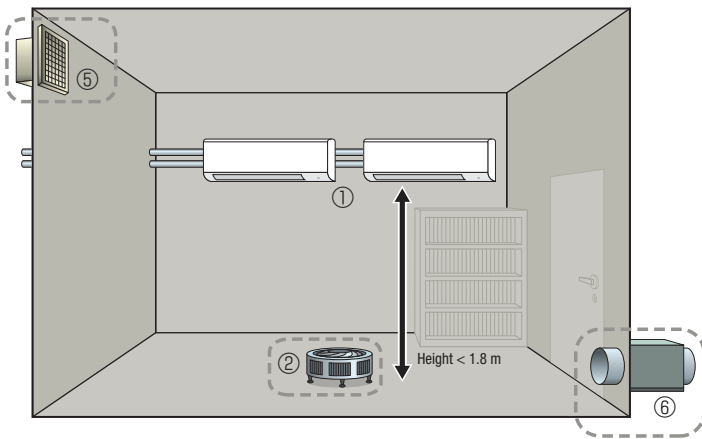

Safety measures:

- Air circulation (permanent operation or controlled via refrigerant detector)
- Mechanical ventilation (permanent operation or activated via refrigerant detector)

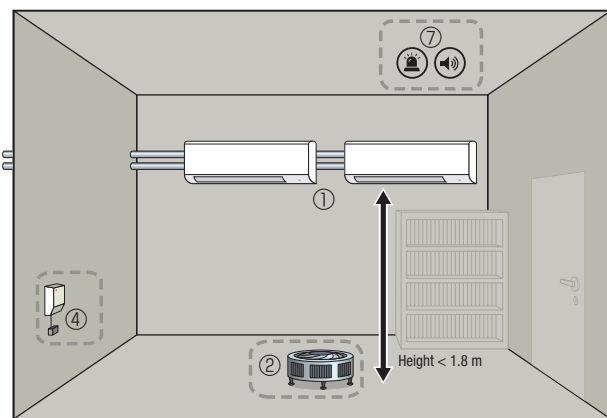

Safety measures:

- Air circulation (permanent operation or controlled via refrigerant detector)
- Safety alarm unit (controlled via refrigerant detector)

Legend:

- ① Indoor unit
- ② Air circulation
- ③ Stop valves
- ④ Refrigerant detector
- ⑤ Air intake
- ⑥ Mechanical ventilation

- ⑦ Alarm system (acoustic and visual alarm)
- ⑧ Authorised person (e.g. technician)
- ⑨ Poss. monitored location (e.g. retirement home)

Installation in zone 3 or zone 2 (on lowest basement floor) above 1.8 m

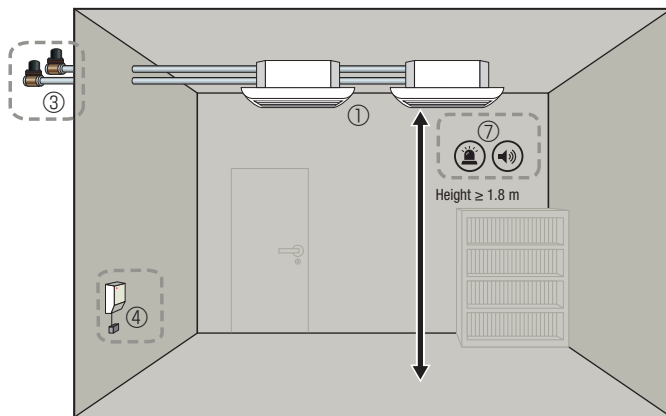

Safety measures:

- Safety alarm unit (controlled via refrigerant detector)
- Safety stop valves (controlled via refrigerant detector)

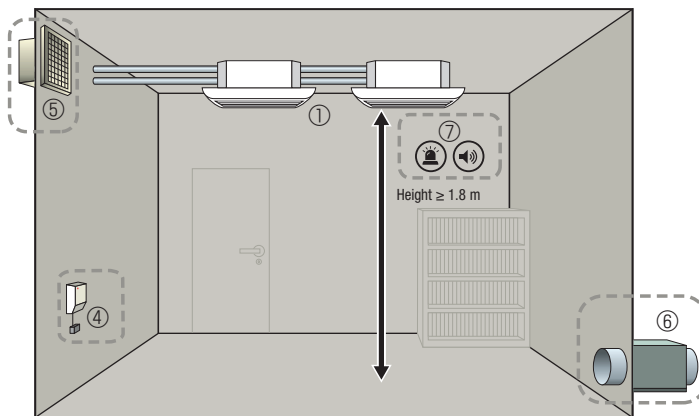

Safety measures:

- Safety alarm unit (controlled via refrigerant detector)
- Mechanical ventilation (permanent operation or activated via refrigerant detector)

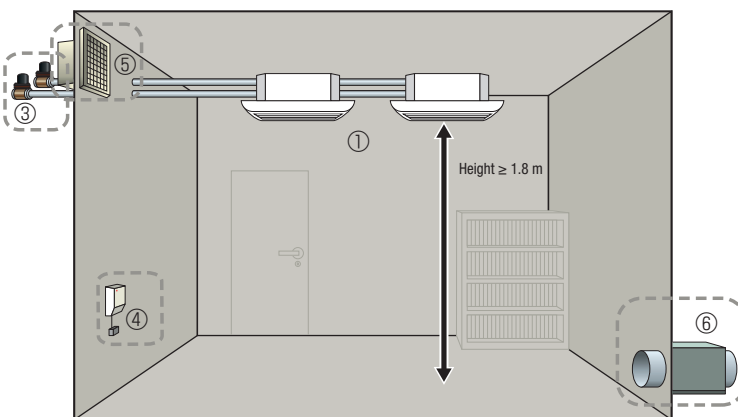

Safety measures:

- Safety stop valves (controlled via refrigerant detector)
- Mechanical ventilation (permanent operation or activated via refrigerant detector)

Legend:

- ① Indoor unit
- ③ Stop valve
- ④ Refrigerant detector

- ⑤ Air intake
- ⑥ Mechanical ventilation
- ⑦ Alarm system (acoustic and visual alarm)

- ⑧ Authorised person (e.g. technician)
- ⑨ Poss. monitored location (e.g. retirement home)

Installation in zone 3 or zone 2 (on lowest basement floor) below 1.8 m

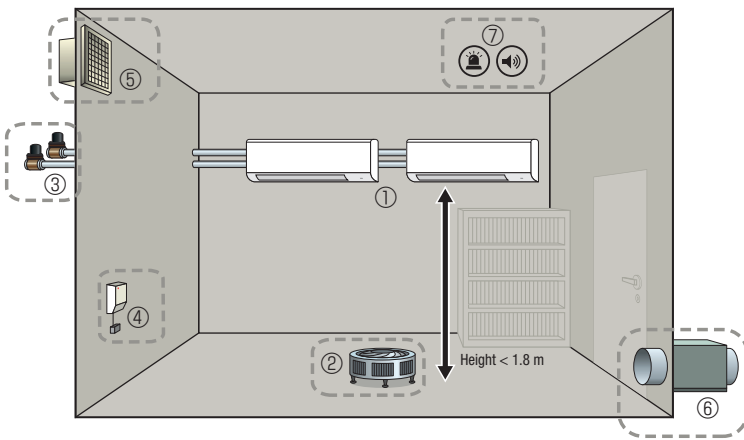

Safety measures:

- Air circulation (permanent operation or controlled via refrigerant detector)
- Mechanical ventilation (permanent operation or activated via refrigerant detector)
- Safety alarm unit (controlled via refrigerant detector)

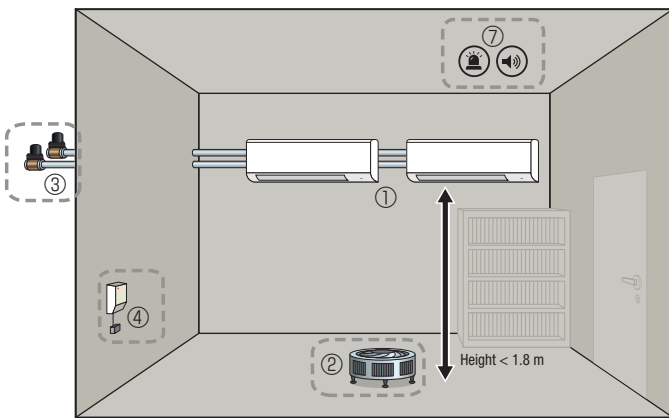

Safety measures:

- Air circulation (permanent operation or controlled via refrigerant detector)
- Safety alarm unit (controlled via refrigerant detector)
- Safety stop valves (controlled via refrigerant detector)

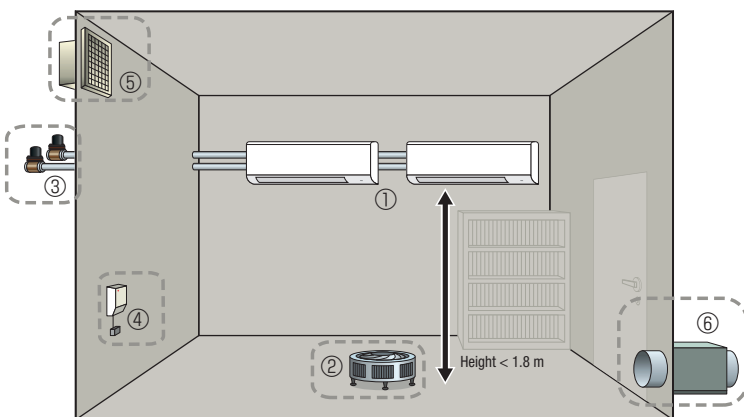

Safety measures:

- Air circulation (permanent operation or controlled via refrigerant detector)
- Safety alarm unit (controlled via refrigerant detector)
- Safety stop valves (controlled via refrigerant detector)

Legend:

- ① Indoor unit
- ② Air circulation
- ③ Stop valves

- ④ Refrigerant detector
- ⑤ Air intake
- ⑥ Mechanical ventilation

- ⑦ Alarm system (acoustic and visual alarm)
- ⑧ Authorised person (e.g. technician)
- ⑨ Poss. monitored location (e.g. retirement home)

5.2 Installation of pipes

Installation in zone 1 above 1.8 m

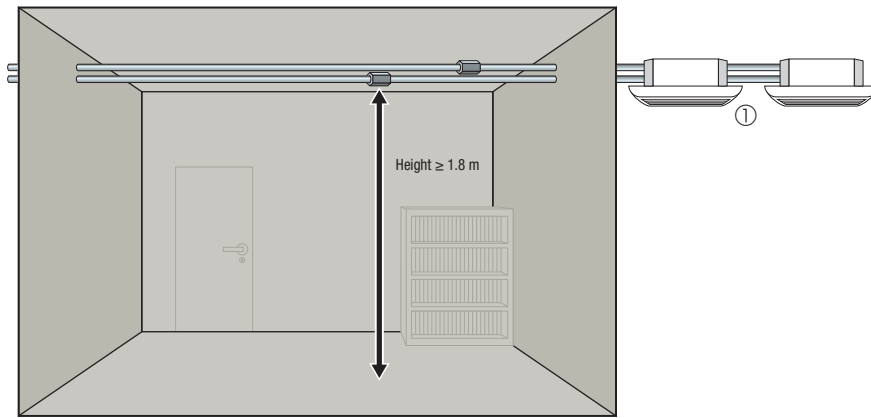

Safety measures:

- None

Legend:

- ① Indoor unit

Installation in zone 1 below 1.8 m

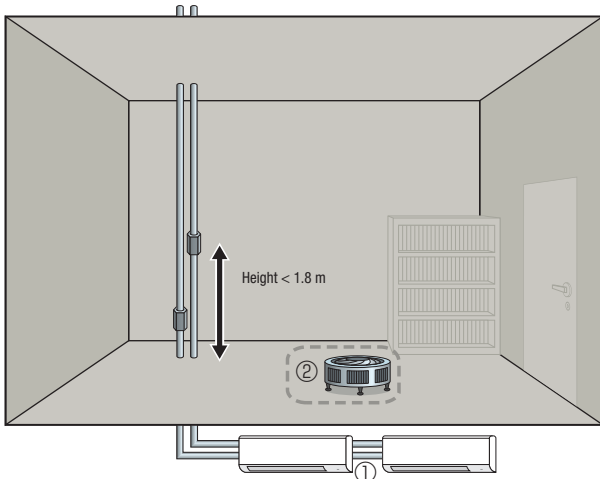

Safety measures:

- Air circulation (permanent operation or controlled via refrigerant detector)

Note:

The vertical routing of refrigerant pipes through an occupied area must automatically be considered a floor installation.

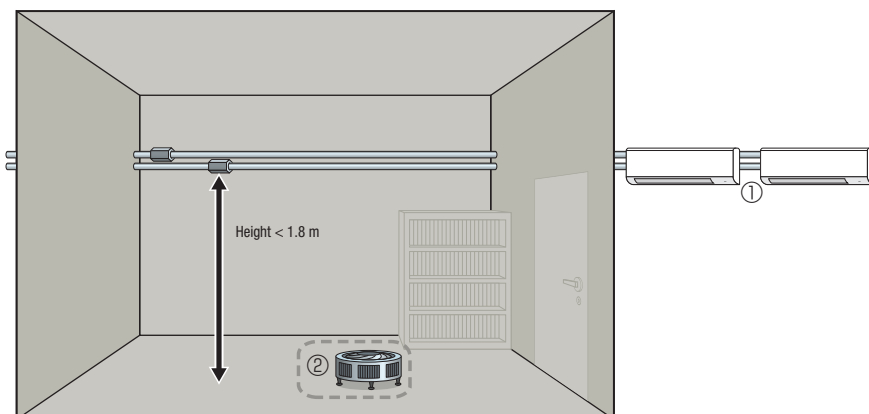

Safety measures:

- Air circulation (permanent operation or controlled via refrigerant detector)

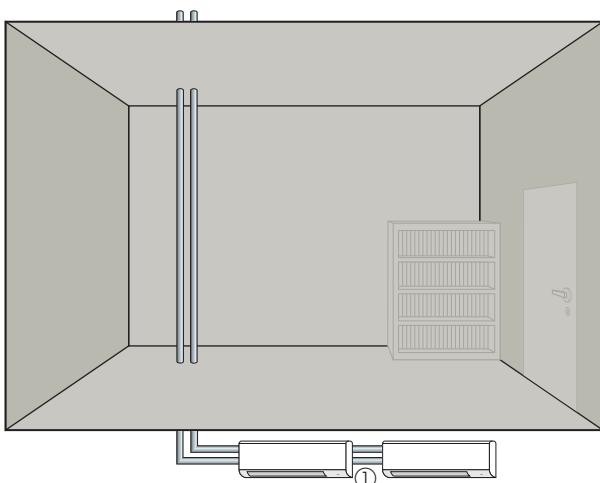

Safety measures:

- None

Legend:
 ① Indoor unit
 ② Air circulation

Installation in zone 2 above 1.8 m

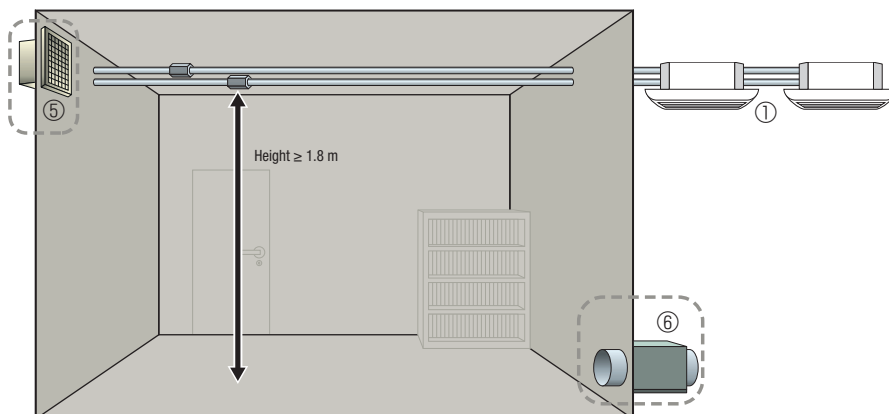

Safety measures:

- Mechanical ventilation (permanent operation or activated via refrigerant detector)

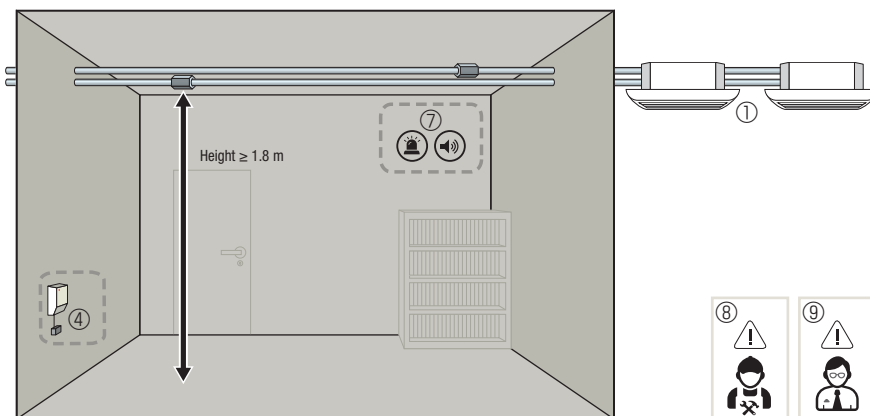

Safety measures:

- Safety alarm unit (controlled via refrigerant detector)

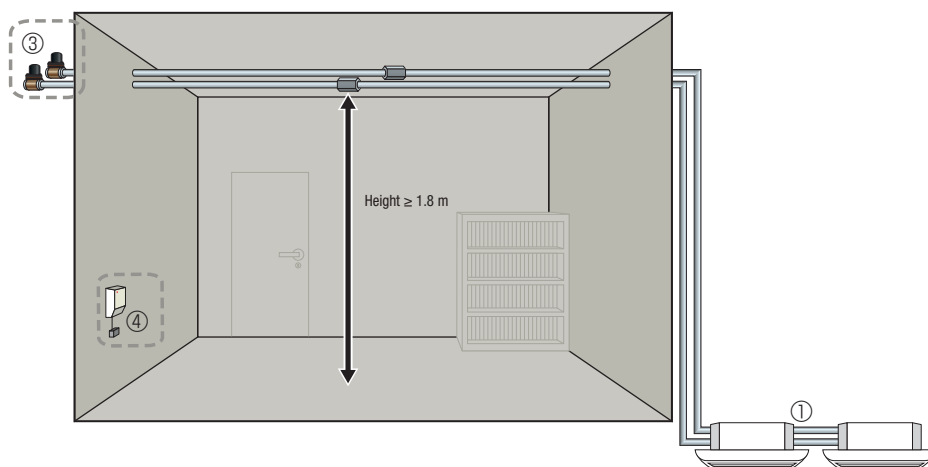

Safety measures:

- Safety stop valves (controlled via refrigerant detector)

Legend:

- | | | |
|------------------------|--|---|
| ① Indoor unit | ⑤ Air intake | ⑧ Authorised person (e.g. technician) |
| ③ Stop valve | ⑥ Mechanical ventilation | ⑨ Poss. monitored location (e.g. retirement home) |
| ④ Refrigerant detector | ⑦ Alarm system (acoustic and visual alarm) | |

Installation in zone 2 below 1.8 m

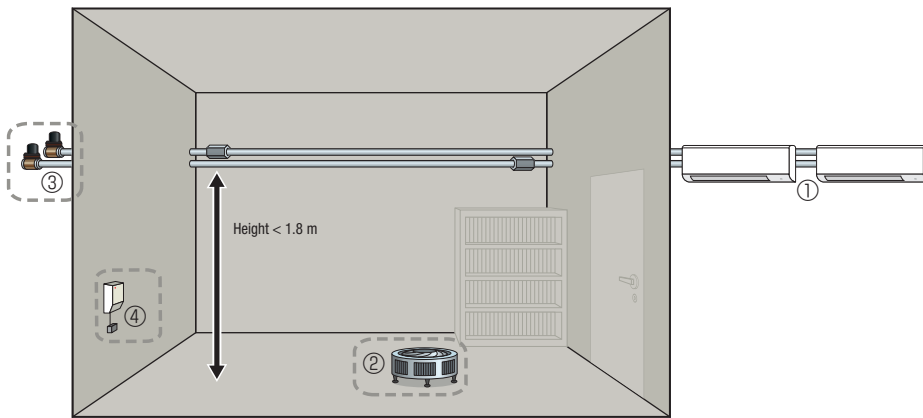

Safety measures:

- Air circulation (permanent operation or controlled via refrigerant detector)
- Safety stop valves (activated via refrigerant detector)

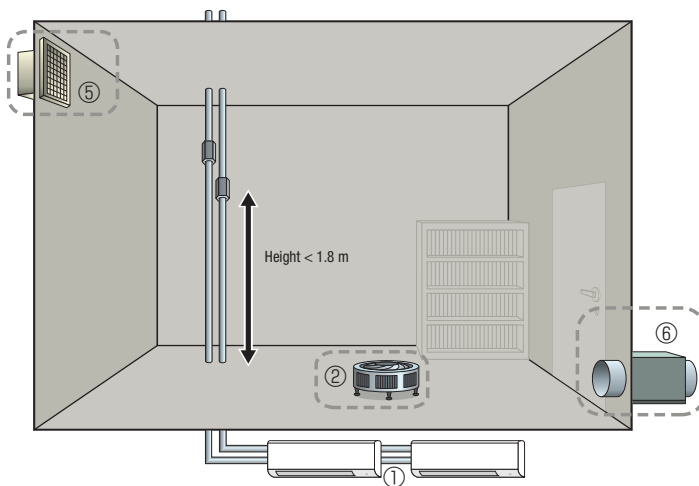

Safety measures:

- Air circulation (permanent operation or controlled via refrigerant detector)
- Mechanical ventilation (permanent operation or activated via refrigerant detector)

Note:

The vertical routing of refrigerant pipes through an occupied area must automatically be considered a floor installation.

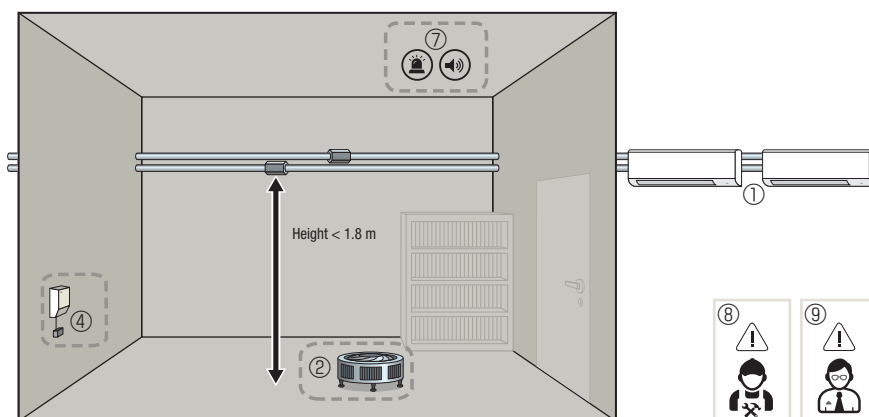

Safety measures:

- Air circulation (permanent operation or controlled via refrigerant detector)
- Safety alarm unit (controlled via refrigerant detector)



Legend:

- ① Indoor unit
- ③ Stop valve
- ④ Refrigerant detector

- ⑤ Air intake
- ⑥ Mechanical ventilation
- ⑦ Alarm system (acoustic and visual alarm)

- ⑧ Authorised person (e.g. technician)
- ⑨ Poss. monitored location (e.g. retirement home)

Installation in zone 3 or zone 2 (on lowest basement floor) above 1.8 m

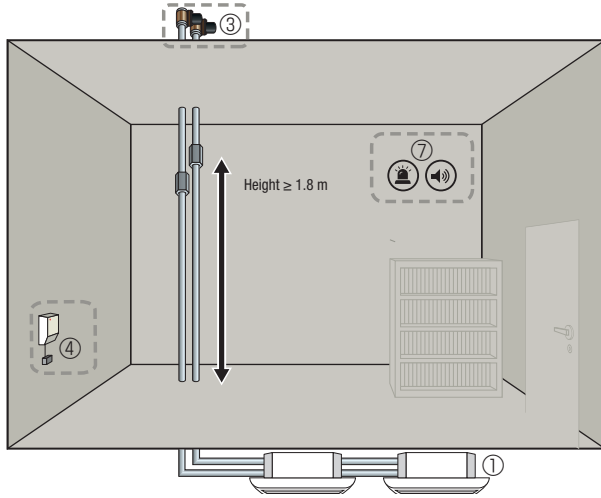

Safety measures:

- Safety alarm unit (controlled via refrigerant detector)
- Safety stop valves (controlled via refrigerant detector)

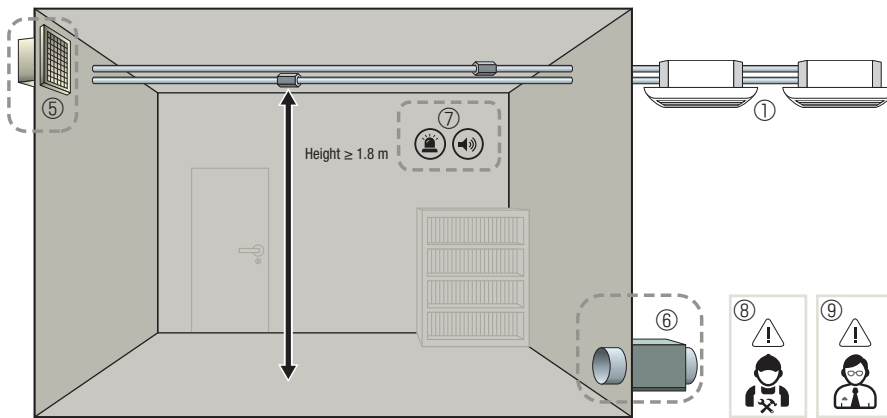

Safety measures:

- Safety alarm unit (controlled via refrigerant detector)
- Mechanical ventilation (permanent operation or activated via refrigerant detector)

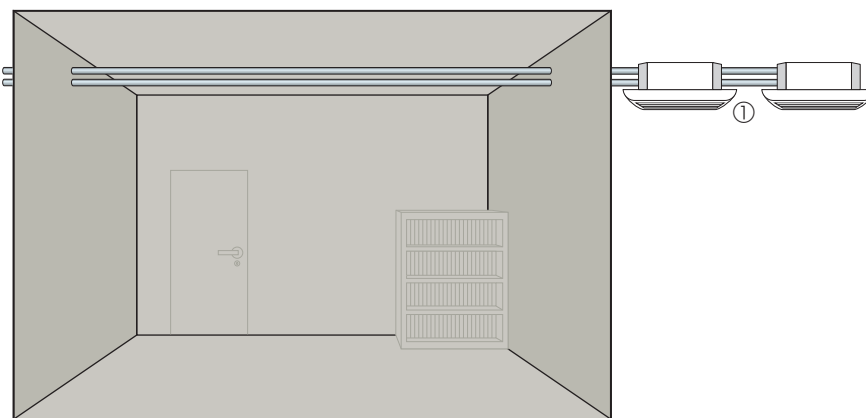

Safety measures:

- None

Legend:

- ① Indoor unit
- ③ Stop valve
- ④ Refrigerant detector

- ⑤ Air intake
- ⑥ Mechanical ventilation
- ⑦ Alarm system (acoustic and visual alarm)

- ⑧ Authorised person (e.g. technician)
- ⑨ Poss. monitored location (e.g. retirement home)

Installation in zone 3 or zone 2 (on lowest basement floor) below 1.8 m

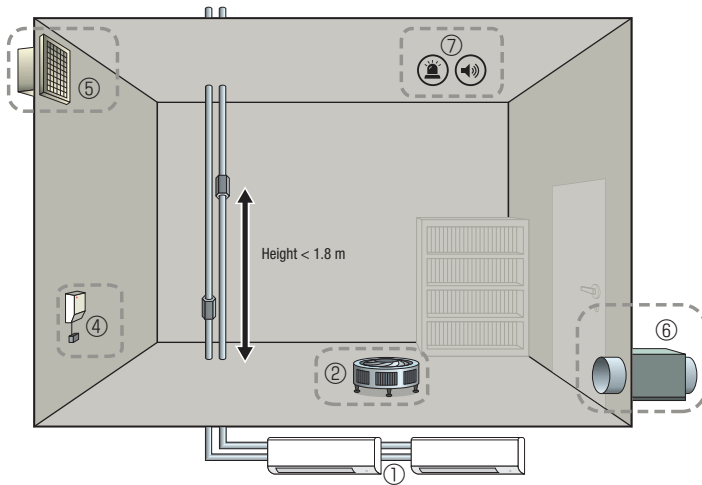

Safety measures:

- Air circulation (permanent operation or controlled via refrigerant detector)
- Mechanical ventilation (permanent operation or activated via refrigerant detector)
- Safety alarm unit (controlled via refrigerant detector)

Note:

The vertical routing of refrigerant pipes through an occupied area must automatically be considered a floor installation.

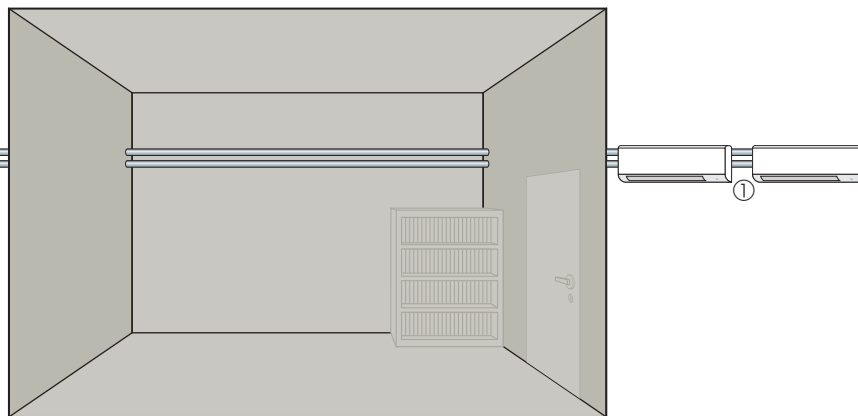

Safety measures:

- None

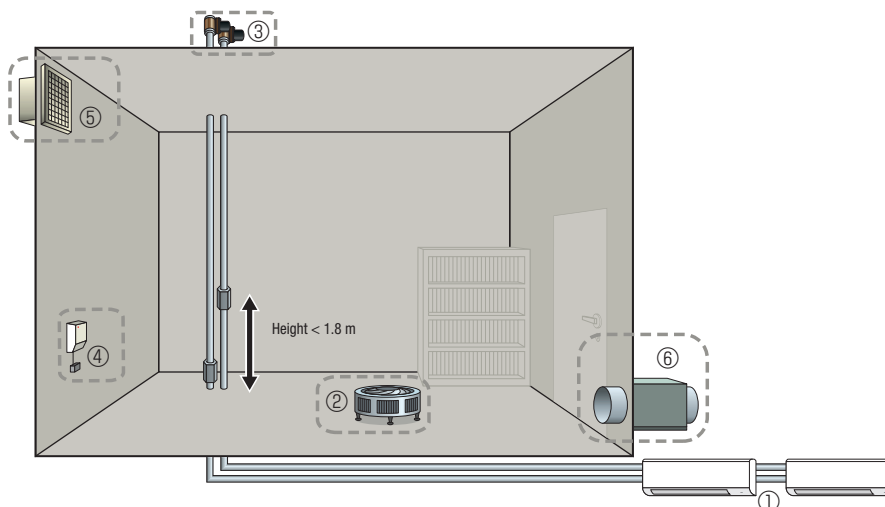

Safety measures:

- Air circulation (permanent operation or controlled via refrigerant detector)
- Safety alarm unit (controlled via refrigerant detector)
- Safety stop valves (controlled via refrigerant detector)

Note:

The vertical routing of refrigerant pipes through an occupied area must automatically be considered a floor installation.

Legend:

- | | | |
|-------------------|--------------------------|---|
| ① Indoor unit | ④ Refrigerant detector | ⑦ Alarm system (acoustic and visual alarm) |
| ② Air circulation | ⑤ Air intake | ⑧ Authorised person (e.g. technician) |
| ③ Stop valves | ⑥ Mechanical ventilation | ⑨ Poss. monitored location (e.g. retirement home) |

Mitsubishi Electric

On-site for you

Headquarters

Living Environment Systems
Mitsubishi-Electric-Platz 1
D-40882 Ratingen
Phone +49 2102 486-0
Fax +49 2102 486-1120

Bremen

PLZ 26–28, 49
Max-Pechstein-Straße 6
D-28816 Stuhr
Phone +49 40 55620347-0
Fax +49 40 55620347-99
les-bremen@meg.mee.com

Dortmund

PLZ 41, 44, 57–59
Mitsubishi-Electric-Platz 1
D-40882 Ratingen
Phone +49 2102 486-8521
Fax +49 2102 486-4664
les-dortmund@meg.mee.com

Kaiserslautern

PLZ 54, 66–69
Seligenstädter Grund 1
D-63150 Heusenstamm
Phone +49 6104 80243-0
Fax +49 6104 80243-29
les-kaiserslautern@meg.mee.com

Munich

PLZ 80–88
Rollnerstraße 12
D-90408 Nuremberg
Phone +49 711 327001-610
Fax +49 2102 486666-8620
les-muenchen@meg.mee.com

Key Account

PLZ 01–99
Mitsubishi-Electric-Platz 1
D-40882 Ratingen
Phone +49 2102 486-4176
Fax +49 2102 486-4664
les-keyaccount@meg.mee.com

Berlin

PLZ 10–18, 39
Hauptstraße 80
D-16348 Wandlitz (Schönwalde)
Phone +49 40 55620347-0
Fax +49 40 55620347-99
les-berlin@meg.mee.com

Cologne

PLZ 42, 50–53
Mitsubishi-Electric-Platz 1
D-40882 Ratingen
Phone +49 2102 486-8521
Fax +49 2102 486-4664
les-koeln@meg.mee.com

Stuttgart

PLZ 70–74, 89
Schelmenwasenstraße 16–20
D-70567 Stuttgart
Phone +49 711 327001-610
Fax +49 711 327001-615
les-stuttgart@meg.mee.com

Hamburg

PLZ 19–25
Borsteler Bogen 27 D
D-22453 Hamburg
Phone +49 40 55620347-0
Fax +49 40 55620347-99
les-hamburg@meg.mee.com

Dresden

PLZ 01–09, 98–99
Asterweg 16
D-09648 Altmittweida
Phone +49 40 55620347-0
Fax +49 2102 486-8616
les-dresden@meg.mee.com

Frankfurt

PLZ 35, 36, 55, 56, 60–65
Seligenstädter Grund 1
D-63150 Heusenstamm
Phone +49 6104 80243-0
Fax +49 6104 80243-29
les-frankfurt@meg.mee.com

Baden-Baden

PLZ 75–79
Schelmenwasenstraße 16–20
D-70567 Stuttgart
Phone +49 711 327001-610
Fax +49 711 327001-615
les-badenbaden@meg.mee.com

Hanover

PLZ 29–31, 38
Borsteler Bogen 27 D
D-22453 Hamburg
Phone +49 40 55620347-0
Fax +49 40 55620347-99
les-hannover@meg.mee.com

Düsseldorf

PLZ 40, 45–48
Mitsubishi-Electric-Platz 1
D-40882 Ratingen
Phone +49 2102 486-8521
Fax +49 2102 486-4664
les-duesseldorf@meg.mee.com

Kassel

PLZ 32–34, 37
Mitsubishi-Electric-Platz 1
D-40882 Ratingen
Phone +49 2102 486-8521
Fax +49 2102 486-4664
les-kassel@meg.mee.com

Nuremberg

PLZ 90–97
Rollnerstraße 12
D-90408 Nuremberg
Phone +49 711 327001-610
Fax +49 2102 486666-8618
les-nuernberg@meg.mee.com



Our air conditioning systems and heat pumps contain fluorinated greenhouse gases R410A, R407C, R134a and R32.
For more information, please refer to the relevant operation manuals.

No liability is assumed for the correctness of the information and illustrations provided. Not all products are available in all countries.