



Maritime and Coastguard Agency

---

---

**The Merchant Shipping (Life-Saving Appliances for Ships Other Than Ships of Classes III to VI(A)) Regulations 1999**

**The Merchant Shipping (Life-Saving Appliances for Passenger Ships of Classes III to VI(A)) Regulations 1999**

Notice to Shipowners, Certifying Authorities, Shipbuilders, Shiprepairers, Ship Masters and Surveyors

---

---

*Summary*

This Notice advises all Shipowners, Shipbuilders, Ship Repairers, Ship Masters, Certifying Authorities and Surveyors of the new 1999 Life-Saving Appliances Regulations.

Key Points:-

- This Notice forms an integral part of the Merchant Shipping (Life-Saving Appliances for Ships Other than Ships of Classes III to VI(A)) Regulations 1999; and the Merchant Shipping (Life-Saving Appliances for Passenger Ships of Classes III to VI(A)) Regulations 1999.
- Schedules contained in this Notice are invoked by those Regulations and are therefore a statutory obligation.

**List of Schedules**

- Schedule 1:           General Requirements for all life-saving appliances
- Schedule 2:           Lifeboats, rigid rescue boats and fast rescue boats
- Part 1   General
  - Part 2   Lifeboats
  - Part 3   Partially enclosed lifeboats
  - Part 4   Totally enclosed lifeboats
  - Part 5   Lifeboats with self-contained air support system
  - Part 6   Fire-protected lifeboats
  - Part 7   Rigid rescue boats
  - Part 8   Rigid inflated rescue boats
  - Part 9   Free-fall lifeboats
  - Part 10  Fast rescue boats, rigid and rigid inflated

- Schedule 3: Inflated rescue boats and inflated boats
- Part 1 General
  - Part 2 Inflated rescue boats
  - Part 3 Inflated boats (Non-SOLAS)
- Schedule 4: Liferafts
- Part 1 General
  - Part 2 Inflatable liferafts
  - Part 3 Rigid liferafts
  - Part 4 Open reversible liferafts
  - Part 5 Inflatable liferafts (Non-SOLAS)
  - Part 6 Liferaft equipment (SOLAS)
  - Part 7 Automatic release hooks
  - Part 8 Float free arrangements
  - Part 9 Liferaft lights
- Schedule 5: Marine escape systems and means of rescue system
- Part 1 Marine evacuation system
  - Part 2 Training
  - Part 3 Means of rescue system
- Schedule 6: Launching appliances and embarkation ladders
- Part 1 General
  - Part 2 Lifeboat and rescue boat launching appliances
  - Part 3 Liferaft launching appliances
  - Part 4 Inflated boat launching appliances
  - Part 5 Embarkation ladders
- Schedule 7: Pyrotechnic signals and line throwing appliances
- Part 1 General
  - Part 2 Rocket parachute flares
  - Part 3 Hand flares
  - Part 4 Buoyant smoke signals
  - Part 5 Line throwing appliances
  - Part 6 Information, instruction and stowage
- Schedule 8: Lifebuoys and attachments
- Part 1 General
  - Part 2 Lifebuoys (SOLAS)
  - Part 3 Lifebuoys (610 millimetres)
  - Part 4 Lifebuoy self-igniting lights
  - Part 5 Lifebuoy self-activating smoke signals
  - Part 6 Lifebuoy buoyant lifelines
- Schedule 9: Lifejackets and attachments
- Part 1 General
  - Part 2 Inherently buoyant lifejackets (over 32 kilogrammes)
  - Part 3 Inherently buoyant lifejackets (under 32 kilogrammes)
  - Part 4 Inflatable lifejackets
  - Part 5 Inflatable Civil Aviation Authority lifejacket
  - Part 6 Buoyancy aids

- Schedule 10: Requirements for immersion suits, anti-exposure suits and thermal protective aids
- Part 1 Immersion suits  
Part 2 Anti-exposure suits  
Part 3 Thermal protective aids
- Schedule 11: General emergency alarm systems and public address systems
- Part 1 General emergency alarm systems  
Part 2 Public address systems
- Schedule 12: Buoyant apparatus
- Schedule 13: Survival craft equipment and rations
- Part 1 First aid outfits  
Part 2 Food rations  
Part 3 Fresh water  
Part 4 Sea-anchors
- Schedule 14: Training manuals and instructions for on-board maintenance
- Part 1 Training manuals  
Part 2 Instructions for on-board maintenance
- Schedule 15: Carriage of two-way VHF radiotelephone sets - exempting conditions
- Schedule 16: Symbols relating to life-savings appliances and arrangements

In this Merchant Shipping Notice –

- (1) a reference to a numbered paragraph is, unless otherwise stated, a reference to the paragraph of that number in that Part;
- (2) a reference to a numbered section is, unless otherwise stated, a reference to the section of that number in that Part;
- (3) a reference to a numbered Part is, unless otherwise stated, a reference to the Part of that number in that Schedule;
- (4) a reference to a numbered Schedule, is unless otherwise stated, a reference to the Schedule of that number in the Merchant Shipping Notice;
- (5) a reference to the Small Passenger Ships Regulations means a reference to the Merchant Shipping (Life-saving Appliances for Passenger Ships of Classes III to VI(A)) Regulations 1999;
- (6) a reference to the Other Ships Regulations means a reference to the Merchant Shipping (Life-saving Appliances for Ships Other Than Ships of Classes III to VI(A)) Regulations 1999.

## SCHEDULE 1

### GENERAL REQUIREMENTS FOR ALL LIFE-SAVING APPLIANCES

1. Unless expressly provided otherwise, all life-saving appliances shall –
  - 1.1 be constructed with proper workmanship and materials;
  - 1.2 not be damaged in stowage in the air temperature range  $-30^{\circ}\text{C}$  to  $+65^{\circ}\text{C}$ ;
  - 1.3 be capable of operating in the sea water temperature range of  $-1^{\circ}\text{C}$  to  $+30^{\circ}\text{C}$ ;
  - 1.4 be rot-proof, corrosion-resistant, and not be unduly affected by seawater, oil or fungal attack;
  - 1.5 be resistant to deterioration from exposure to sunlight;
  - 1.6 be of a highly visible colour on all parts where this will assist detection;
  - 1.7 be fitted with retro-reflective material where it will assist in detection and the dimensions and location of the material shall be sufficient for this purpose;
  - 1.8 be capable of satisfactory operation in a sea environment;
  - 1.9 be clearly marked with approval information including the Administration which approved it, and any operational restrictions;
  - 1.10 where applicable, be provided with electrical short circuit protection to prevent damage or injury; and
  - 1.11 life-saving appliances which are subject to deterioration with age shall be marked with a means for determining their age or the date by which they must be replaced. Permanent marking with a date of expiry is the preferred method of establishing the period of acceptability. Batteries not marked with an expiry date may be used if they are replaced annually, or in the case of a secondary battery or accumulator, if the condition of the electrolyte can be readily checked.



## SCHEDULE 2

### LIFEBOATS, RIGID RESCUE BOATS AND FAST RESCUE BOATS

#### PART 1 – GENERAL

##### *Definitions*

1. In this Schedule the following definition applies –

“Length of lifeboat or rigid rescue boat or fast rescue boat” means the length of the boat in metres from the inside of the shell at the top of the stem to the corresponding point at the top of the stern post; in the case of a boat with a square stern the length is measured to the inside of the top of the transom.

##### *General*

2. Lifeboats, rigid rescue and fast rescue boats shall comply with the requirements of Schedule 1 and, in addition, with the requirements of this Part.

##### *Construction*

- 3.1 Boats shall be properly constructed and shall be of such form and proportions that they have ample stability in a seaway and sufficient freeboard when loaded with their full complement of persons and equipment. Boats shall have rigid hulls and shall be capable of maintaining positive stability when in an upright position in calm water and loaded with their full complement of persons and equipment and holed in any one location below the waterline, assuming no loss of buoyancy material and no other damage.
- 3.2 Boats shall be of sufficient strength to –
  - 3.2.1 enable them to be safely lowered into the water when loaded with their full complement of persons and equipment; and
  - 3.2.2 be capable of being launched and towed when the ship is making headway at a speed of 5 knots in calm water.
- 3.3 Hulls and rigid covers shall be fire-retardant or non-combustible.
- 3.4 Seating shall be provided on thwarts, benches or fixed chairs which are constructed so as to be capable of supporting:
  - 3.4.1 a static load equivalent to the number of persons each weighing 100 kilogrammes for which spaces are provided in compliance with the requirements of Part 2 paragraph 2.3, Part 5 paragraph 2 or Part 8 paragraph 2.1 as appropriate;
  - 3.4.2 a load of 100 kilogrammes in any single seat location when a lifeboat to be launched by falls is dropped into the water from a height of at least 3 metres; and
  - 3.4.3 a load of 100 kilogrammes in any single seat location when a free-fall lifeboat is launched from a height of at least 1.3 times its free-fall certification height.

- 3.5 Except for free-fall lifeboats, each boat shall be of sufficient strength to withstand a load, without residual deflection on removal of that load –
- 3.5.1 in the case of boats with metal hulls, 1.25 times the total mass of the boat when loaded with its full complement of persons and equipment; or
  - 3.5.2 in the case of other boats, twice the total mass of the boat when loaded with its full complement of persons and equipment.
- 3.6 Except for free-fall lifeboats, each boat shall be of sufficient strength to withstand, when loaded with its full complement of persons and equipment and fitted, where applicable, with skates or fenders-
- 3.6.1 a lateral impact against the ship's side at an impact velocity of at least 3.5 metres per second; and
  - 3.6.2 also a drop into the water from a height of at least 3 metres.
- 3.7 Each seating position shall be clearly indicated in the boat.
- 3.8 Boats shall have a boarding ladder that can be used on either side of the boat to enable persons in the water to board the boat. The lowest step of the ladder shall be not less than 0.4 metres below the boat's light waterline and shall be weighted if of buoyant material.
- 3.9 The boat shall be so arranged that helpless people can be brought on board either from the sea or on stretchers.
- 3.10 Surfaces on which persons might walk shall have a non-skid finish.
- 3.11 Boats shall have inherent buoyancy or shall be fitted with inherently buoyant material, which shall not be adversely affected by seawater, oil or oil-products, sufficient to float the boat with all its equipment on board when flooded and open to the sea. Additional inherently buoyant material, equal to 280 newtons of buoyant force per person shall be provided for the number of persons the boat is permitted to accommodate. Buoyant material, unless in addition to that required above, shall not be installed externally to the hull of the boat.
- 3.12 All lifeboats shall be stable and have a positive GM value when loaded with 50 per cent of the number of persons the lifeboat is permitted to accommodate in their normal positions to one side of the centreline.
- 3.13 Under the condition of loading in paragraph 3.12 –
- 3.13.1 each lifeboat with side openings near the gunwale shall have a freeboard, measured from the waterline to the lowest opening through which the lifeboat may become flooded, of at least 1.5 per cent of the lifeboat's length or 100 millimetres, whichever is the greater; and
  - 3.13.2 each lifeboat without side openings near the gunwale shall not exceed an angle of heel of 20 degrees and shall have a freeboard, measured from the waterline to the lowest opening through which the lifeboat may become flooded, of at least 1.5 per cent of the lifeboat's length or 100 millimetres, whichever is the greater.

### *Propulsion*

- 4.1 Except as permitted by paragraph 3.2 of Part 7 (for rigid rescue boats) every boat shall be powered by a compression ignition engine. No engine shall be used for any boat if its fuel has a flashpoint of 43°C or less (closed cup-test) and the engine shall –

- 4.1.1 be provided with either a manual starting system, or a power starting system with two independent rechargeable energy sources. Any necessary starting aids shall also be provided. The engine starting systems and starting aids shall start the engine at an ambient temperature of -15°C within 2 minutes of commencing the start procedure unless, having regard to the particular voyages in which the ship carrying the boat is constantly engaged, a different temperature is appropriate. The starting systems shall not be impeded by the engine casing, thwarts or other obstructions;
- 4.1.2 be capable of operating for not less than 5 minutes after starting from cold with the boat out of the water; and
- 4.1.3 be capable of operating when the boat is flooded up to the centreline of the crankshaft;
- 4.2 Unless the propeller is arranged so as to avoid its rotation constituting a danger to people in the water adjacent to it, the drive arrangement between the prime mover and the propeller shall be such that the propeller can be brought to rest without stopping the prime mover. Provision shall be made for ahead and astern propulsion of the craft.
- 4.3 The exhaust pipe shall be so arranged as to prevent water from entering the engine in normal operation and insulated as necessary.
- 4.4 Boats shall be designed with due regard to the safety of persons in the water and to the possibility of damage to the propulsion system by floating debris.
- 4.5 The engine, transmission and engine accessories shall be enclosed in a fire-retardant casing or other suitable arrangements providing similar protection. Such arrangements shall also protect persons from coming into accidental contact with hot or moving parts and protect the engine from exposure to weather and sea. Adequate means shall be provided to reduce engine noise. Starter batteries shall be provided with casings which form a watertight enclosure around the bottom and sides of the batteries. The battery casings shall have tight fitting tops which provide for necessary gas venting.
- 4.6 The engine and accessories shall be designed to limit electromagnetic emissions so that engine operation does not interfere with the operation of radio life-saving appliances used in the boat.
- 4.7 Means shall be provided for recharging all engine-starting, radio and searchlight batteries. Radio batteries shall not be used to provide power for engine starting. Means shall be provided for recharging boat batteries from the ship's power supply. The electric power supply connection from the ship to any boat shall be at a voltage not exceeding 55 volts direct current or 55 volts root mean square alternating current and shall be capable of being disconnected automatically at the embarkation station. Charging current may be supplied by means of a solar battery charger.
- 4.8 Water-resistant instructions for starting and operating the engine shall be provided and mounted in a conspicuous place near the engine starting controls.

### *Fittings*

- 5.1 Boats shall be provided with at least one drain valve fitted near the lowest point in the hull, which shall automatically open to drain water from the hull when the boat is not waterborne and shall automatically close to prevent entry of water when the boat is waterborne. Each drain valve shall be provided with a cap or plug to close the valve, which shall be attached to the boat by a lanyard, a chain, or other suitable means. Drain valves shall be readily accessible from inside the boat and their positions shall be clearly indicated.

- 5.2 Boats shall be provided with a rudder and tiller or other suitable means of steering. When a wheel or other remote steering mechanism is also provided the tiller or this means shall be capable of steering the boat in the case of failure of the steering mechanism. Except where the rudder and the tiller form part of an outboard engine the rudder shall be permanently attached to the boat and any tiller shall be permanently installed on or linked to the rudder stock. However if the boat has a remote steering mechanism the tiller may be removable and securely stowed near the rudder stock. The steering arrangements shall be arranged so as not to be damaged by operation of the release mechanism or the propeller.
- 5.3 Except in the vicinity of the rudder, propeller or outboard engine, suitable handholds shall be provided or a buoyant line shall be becketed around the outside of the boat, above the waterline and within reach of a person in the water.
- 5.4 Boats which are not self-righting when capsized shall have suitable handholds on the underside of the hull to enable persons to cling to the boat. The handholds shall be fastened to the boat in such a way that, when subjected to an impact sufficient to cause them to break away from the boat, they break away without damaging the boat.
- 5.5 Every boat to be launched by a fall or falls shall be fitted with a release mechanism complying with section 8.
- 5.6 Every lifeboat shall be fitted with a device to secure painter near its bow. The device shall be such that the lifeboat does not exhibit unsafe or unstable characteristics when being towed by the ship making headway at speeds up to 5 knots in calm water. Except for free-fall lifeboats, the painter securing device shall include a release device to enable the painter to be released from inside the lifeboat, with the ship making headway at speeds up to 5 knots in calm water.
- 5.7 Boats intended for launching down the side of a ship shall have skates and fenders as necessary to facilitate launching and prevent damage to the boat.
- 5.8 Unless expressly provided otherwise, every boat shall be provided with effective means of bailing or be automatically self-bailing.

### *Markings*

- 6.1 Each lifeboat shall be fitted with an identity plate endorsed by the Administration, containing at least the following items:
  - 6.1.1 manufacturer's name and address;
  - 6.1.2 lifeboat model and serial number;
  - 6.1.3 month and year of manufacture;
  - 6.1.4 number of persons the lifeboat is approved to carry; and
  - 6.1.5 the approval information required under Schedule 1 paragraph 1.9.
- 6.2 The certifying organization shall provide the lifeboat with a certificate of approval which, in addition to the above items, specifies:
  - 6.2.1 number of certificate of approval;
  - 6.2.2 material of hull construction, in such detail as to ensure that compatibility problems in repair should not occur;
  - 6.2.3 total mass fully equipped and fully manned; and

- 6.2.4 statement of approval as to Parts 3, 4, 5, 6, 7, 8, 9 or 10 of Schedule 2.
- 6.3 The name and port of registry of the ship to which the boat belongs shall be marked on each side of the boat's bow in block capitals.
- 6.4 Means of identifying the ship to which the boat belongs and the number of the boat shall be marked in such a way that they are visible from above.

*Instructions and information*

- 7.1 Instructions and information required for inclusion in the training manual and in the instructions for on-board maintenance specified in Schedule 14 shall be in a suitable form. Instructions and information shall be in English, in a clear and concise form, and shall include –
  - 7.1.1 a general description of the boat and its equipment;
  - 7.1.2 the installation arrangements;
  - 7.1.3 operational instructions including use of associated survival equipment;
  - 7.1.4 survival instructions;
  - 7.1.5 emergency repair instructions;
  - 7.1.6 deployment, boarding and launching instructions;
  - 7.1.7 the method of launching from within the boat;
  - 7.1.8 the release from launching appliance;
  - 7.1.9 the on-board maintenance requirements;
  - 7.1.10 the servicing requirements;
  - 7.1.11 the use of engine and accessories; and
  - 7.1.12 the recovery of boat including stowage and securing.

*Disengaging gears*

- 8.1 Except in the case of single point suspension a boat disengaging gear shall be so arranged that all hooks are released simultaneously on the operation of the control mechanism.
- 8.2 The means of effecting release shall be placed near the coxswain's position.
- 8.3 The gear shall have two release capabilities –
  - 8.3.1 a normal release capability which will release the boat only when it is waterborne or when there is no load on the hook; and
  - 8.3.2 an on-load release capability which will release the boat with a load on the hook(s). This release shall be so arranged as to release the boat under any condition of loading from no-load with the boat waterborne to a load of 1.1 times the total mass of the boat when loaded with its full complement of persons and equipment. This release shall be adequately protected against accidental or premature use. Adequate protection shall include special mechanical protection not normally required for offload release, in addition to a danger sign. To prevent an accidental release during

recovery of the boat, the mechanical protection interlock should only engage when the release mechanism is properly and completely reset. To prevent a premature on-load release, on-load operation of the release mechanism should require a deliberate and sustained action by the operator. The release mechanism shall be so designed that crew members in the lifeboat can clearly observe when the release mechanism is properly and completely reset and ready for lifting. Clear operating instructions should be provided with a suitable worded warning notice;

- 8.3.3** where a single fall and hook system is used for launching a lifeboat or rescue boat in combination with a suitable painter, the requirements of paragraph 8.3 need not be applicable; in such an arrangement a single capability to release the lifeboat or rescue boat, only when it is fully waterborne, will be adequate.
- 8.4** The means of connection between the hook, safety device and the operating lever or release unit shall –
- 8.4.1** be arranged and led so as to ensure the efficient operation of the gear;
- 8.4.2** wherever necessary be properly cased in for the safety or efficient action of the gear or for the protection of persons from injury; and
- 8.4.3** where cased in, means shall be provided for lubricating this equipment.
- 8.5** The release control shall be clearly marked in a colour that contrasts with its surroundings, and a suitably worded instruction plate indicating the method of safe operation of the gear shall be provided.
- 8.6** Such parts of the gear as would otherwise be likely to be set fast by rust or corrosion shall be made of non-corrodible metal.
- 8.7** The mechanism shall be designed with a factor of safety of 6 based on the ultimate strength of the materials used, assuming that the mass of the lifeboat is equally distributed.

**Small Passenger Ship Regulations**  
regs 5, 6 and 7

**Other Ships Regulations**  
regs 42, 43, 44, 45, 48,  
63, 64, 65, 66 and 69

## **PART 2 - LIFEBOATS**

### **General**

1. Lifeboats shall comply with the requirements of Part 1, and in addition shall comply with the requirements of this Part.

### **Construction**

- 2.1** The vertical distance between the floor surface and the interior of the enclosure or canopy over 50 per cent of the floor area shall be –
- 2.1.1** not less than 1.3 metres for a lifeboat permitted to accommodate 9 persons or less;
- 2.1.2** not less than 1.7 metres for a lifeboat permitted to accommodate 24 persons or more; and
- 2.1.3** not less than the distance determined by linear interpolation between 1.3 metres and 1.7 metres for a lifeboat permitted to accommodate between 9 and 24 persons.
- 2.2** No lifeboat shall be deemed fit to accommodate more than 150 persons.

- 2.3 The number of persons which a lifeboat shall be permitted to accommodate shall be equal to the lesser of –
- 2.3.1 the number of persons having an average mass of 75 kilogrammes, all wearing lifejackets, that can be seated in a normal position without interfering with the means of propulsion or the operation of any of the lifeboat's equipment; or
- 2.3.2 the number of spaces that can be provided on the seating arrangements in accordance with figure 1. The shapes may be overlapped as shown, provided footrests are fitted and there is sufficient room for legs, and the vertical separation between the upper and lower seats is not less than 350 millimetres.

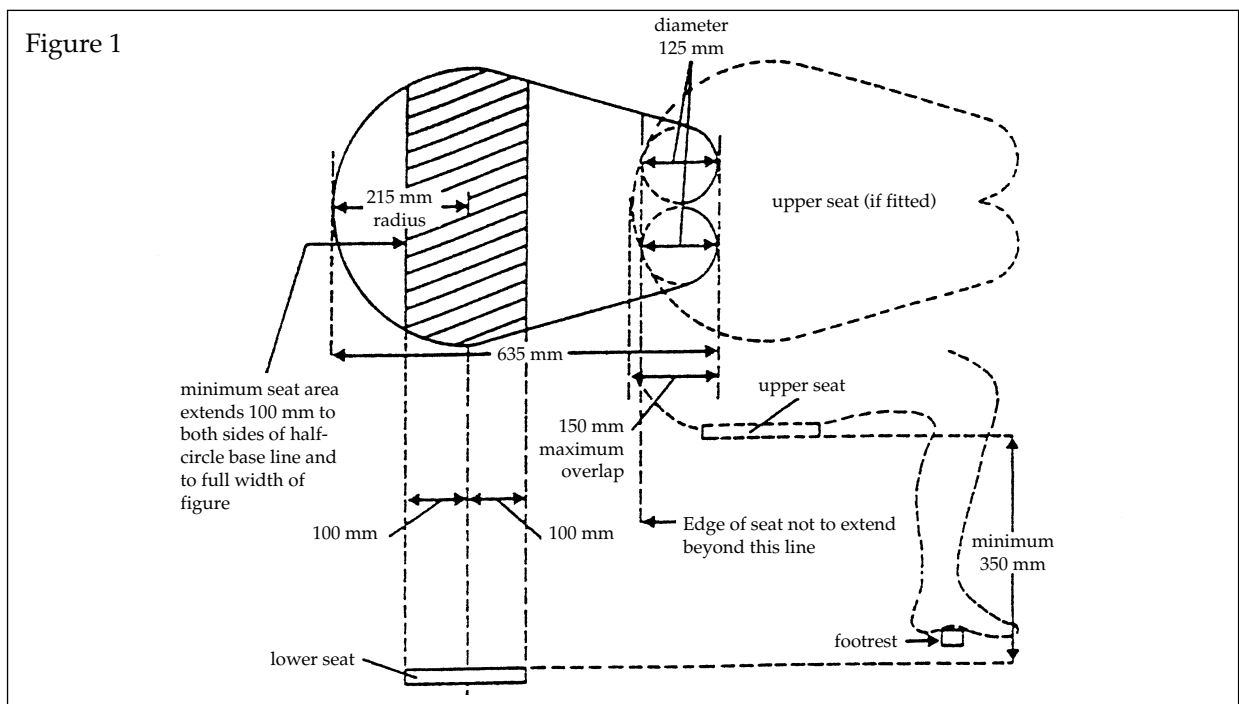

- 2.4 Every passenger ship lifeboat shall be so arranged that it can be rapidly boarded by its full complement of persons. Rapid disembarkation shall also be possible.
- 2.5 Every cargo ship lifeboat shall be so arranged that it can be boarded by its full complement of persons in not more than 3 minutes from the time the instruction to board is given. Rapid disembarkation shall also be possible.

### *Propulsion*

- 3.1 Every lifeboat engine shall be capable of operating when the lifeboat is listed 10 degrees either way or trimmed 10 degrees either way.
- 3.2 The speed of a lifeboat when proceeding ahead in calm water, when loaded with its full complement of persons and equipment and with all engine-powered auxiliary equipment in operation, shall be at least 6 knots and at least 2 knots when towing a 25-person liferaft loaded with its full complement of persons and equipment or its equivalent. Sufficient fuel, suitable for use in the temperature range expected in the area in which the ship operates, shall be provided to run the fully loaded lifeboat at 6 knots for a period of not less than 24 hours.

### *Fittings*

- 4.1 Lifeboats shall be fitted with sufficient watertight lockers or compartments to provide for the storage of the small items of equipment, water and provisions required by section 5. Means shall be provided for the storage of collected rainwater.

- 4.2 Every lifeboat which is fitted with a fixed, two-way VHF radiotelephone apparatus with an antenna which is separately mounted shall be provided with arrangements for siting and securing the antenna effectively in its operating position.
- 4.3 A manually controlled lamp complying with the requirements of section 7 shall be fitted to the top of the cover or enclosure.
- 4.4 A lamp or source of light complying with the requirements of section 7 shall be fitted inside the lifeboat; however, oil lamps shall not be permitted for this purpose.
- 4.5 Every lifeboat shall be so arranged that an adequate view forward, aft and to both sides is provided from the control and steering position for safe launching and manoeuvring.

### *Equipment*

- 5.1 All items of lifeboat equipment, whether required by this paragraph or elsewhere in this Schedule, with the exception of boat-hooks which shall be kept available for fending off purposes, shall be secured within the lifeboat by lashings, storage in lockers or compartments, storage in brackets or similar mounting arrangements or other suitable means. The equipment shall be secured in such a manner as not to interfere with any abandonment procedures. All items of lifeboat equipment shall be as small and of as little mass as possible and shall be packed in a suitable and compact form. Except as stated in paragraph 5.2, the normal equipment of every lifeboat shall consist of –
  - 5.1.1 except for free-fall liferafts, sufficient buoyant oars to make headway in calm seas; thole pins, crutches or equivalent arrangements shall be provided for each oar provided; thole pins or crutches shall be attached to the boat by lanyards or chains;
  - 5.1.2 two boat-hooks;
  - 5.1.3 a buoyant bailer and two buckets;
  - 5.1.4 a survival manual;
  - 5.1.5 an operational compass which is luminous or provided with suitable means of illumination. In a totally enclosed lifeboat the binnacle shall be permanently fitted at the steering position; in any other lifeboat, it shall be provided with suitable mounting arrangements;
  - 5.1.6 a sea-anchor;
  - 5.1.7 two efficient painters of a length equal to not less than twice the distance from the stowage position of the lifeboat to the waterline in the lightest seagoing condition or 15 metres whichever is the greater. On free-fall lifeboats both painters shall be stowed near the bow ready for use. On other lifeboats, one painter attached to the release device required by paragraph 5.6 of Part 1 shall be placed at the forward end of the lifeboat and the other shall be stored at or near the bow of the lifeboat ready for use;
  - 5.1.8 two hatchets, one at each end of the lifeboat;
  - 5.1.9 watertight receptacles complying with the requirements of Schedule 13 and containing a total of 3 litres of fresh water for each person the lifeboat is permitted to accommodate, of which 1 litre per person may be replaced by a de-salting apparatus capable of producing an equal amount of fresh water in 2 days or 2 litres per person may be replaced by a manually powered reverse osmosis desalinator capable of producing an equal amount of fresh water in 2 days;



- 5.1.10 three rustproof graduated drinking vessels, one suitably graduated in millilitres;
  - 5.1.11 food rations totalling not less than 10,000 kilojoules for each person the lifeboat is permitted to accommodate; these rations shall be kept in airtight packaging and be stowed in a watertight container;
  - 5.1.12 four rocket parachute flares;
  - 5.1.13 six hand flares;
  - 5.1.14 two buoyant smoke signals;
  - 5.1.15 one waterproof electric torch suitable for Morse signalling together with one spare set of batteries and one spare bulb in a waterproof container;
  - 5.1.16 one daylight signalling mirror with instructions for its use for signalling to ships and aircraft;
  - 5.1.17 one copy of the Department of Transport's Rescue Signal Table published by Her Majesty's Stationery Office;
  - 5.1.18 one whistle or equivalent sound signal;
  - 5.1.19 a first-aid outfit complying with the requirements of Schedule 13;
  - 5.1.20 anti-seasickness medicine sufficient for 48 hours and one seasickness bag for each person;
  - 5.1.21 a jack-knife to be kept attached to the boat by a lanyard;
  - 5.1.22 three tin openers;
  - 5.1.23 two buoyant rescue quoits, attached to not less than 30 metres of buoyant line;
  - 5.1.24 if the lifeboat is not automatically self bailing, a manual pump complying with the requirements of section 6;
  - 5.1.25 one set of fishing tackle;
  - 5.1.26 sufficient tools for minor adjustments to the engine and its accessories;
  - 5.1.27 two portable fire extinguishers suitable for extinguishing oil fires;
  - 5.1.28 a searchlight with a horizontal and vertical sector of at least 6 degrees and a measured luminous intensity of 2500 candela which can work continuously for not less than 3 hours;
  - 5.1.29 an efficient radar reflector unless a radar transponder is stowed in the lifeboat; and
  - 5.1.30 thermal protective aids sufficient for 10 per cent of the number of persons the lifeboat is permitted to accommodate or two, whichever is the greater.
- 5.2 In the case of ships engaged on voyages solely within the Limited European Area the items specified in paragraphs 5.1.11 and 5.1.25 need not be carried and, in the case of passenger ships of Classes III to VI(A), equipment specified in paragraph 5.1.5, 5.1.16, 5.1.17, 5.1.28, 5.1.29 and 5.1.30 need not be provided.

("Limited European Trading Area" means "an area bounded by a line from a point on the Norwegian coast in latitude 62° North to a point 62° North 02° West; thence to a point 58° North 10° West; thence to a point 54° North 14° West; thence to a point 51° North 14° West; thence to a point 38° 40' North 10° West; thence to Cape St Vincent; but excluding all waters which lie to the northward and eastward of a line between Kalmar on the East coast of Sweden and a point on the West coast of Oland in latitude 56° 40' North and from the southern tip of Oland to Gdnask, except between the dates of 1st May and 30th November when the remaining waters of the Baltic Sea are included.)

### *Manual pump*

- 6.1 Every lifeboat manual pump shall comply with the requirements of this section.
- 6.2 The capacity of the pump when operated at not more than 60 double strokes per minute at 1.2 metres suction head, shall be not less than –
  - 6.2.1 30 litres per minute in lifeboats of 7 metres in length or over; or
  - 6.2.2 20 litres per minute in lifeboats of less than 7 metres in length;
- 6.3 In its normal dry state (excluding internal grease or other assistance) the pump shall be self-priming when operated at a suction head of not less than 1.2 metres.
- 6.4 All parts of the pump shall be of a material unaffected by the corrosive effects of sea water.
- 6.5 The interior of the pump, including valves, shall be readily accessible for emergency cleaning and the cover for access shall be capable of being easily removed without the use of a spanner or other special tool.
- 6.6 The pump branches shall be suitable for use with rubber hose connections of at least 30 millimetres bore. The metal part of the operating handle shall be suitably sheathed by material other than wood to ensure that the hands of the operator are protected when the pump is used in extreme cold. The spindle gland shall be of the spring loaded seal ring type.

### *Internal and external lights*

#### *General*

- 7.1.1 Internal and external lights provided in accordance with paragraph 4.3. and 4.4 shall have a manually operated switch.
- 7.1.2 Each light shall be connected independently to its own power source unless it is operated from the lifeboat's battery system.

#### *Construction*

- 7.2.1 Each complete light unit shall be constructed with proper workmanship and materials.
- 7.2.2 It shall be capable of withstanding the drop test for a lifeboat.
- 7.2.3 It shall be capable of withstanding a drop of 2 metres onto a rigidly mounted steel plate or concrete surface.
- 7.2.4 It shall be rot proof, corrosion resistant and not unduly affected by sea-water, oil or fungal growth.

- 7.2.5 It shall not deteriorate due to damp or humidity when stowed in or on a lifeboat.
- 7.2.6 Its power source shall be proofed against leakage of any chemicals which could damage or cause deterioration of the lifeboat.
- 7.2.7 Its connection between light and power shall be suitably protected.
- 7.2.8 Its lamp, lamp holder and lens shall be so constructed as to prevent the ingress of water.
- 7.2.9 If an external light is a flashing light, it shall not be fitted with a lens or curved reflector to concentrate the beam.

*Performance*

- 7.3.1 Each light shall have an operational endurance of not less than 12 hours.
- 7.3.2 It shall not be damaged in stowage in the air temperature range  $-30^{\circ}\text{C}$  to  $+65^{\circ}\text{C}$ .
- 7.3.3 It shall operate in a satisfactory manner in a seawater temperature range of  $-1^{\circ}\text{C}$  to  $+30^{\circ}\text{C}$ .
- 7.3.4 Each internal light shall be of sufficient luminous intensity to enable survival and equipment instructions to be read.
- 7.3.5 Each external light shall be white and be capable of operating continuously with a luminous intensity of not less than 4.3 candela.
- 7.3.6 Each external light shall be visible through 360 degrees in a horizontal direction and in all directions of the upper hemisphere.
- 7.3.7 If the external light is a flashing light it shall flash at a rate of not less than 50 flashes or more than 70 flashes per minute for the 12 hours operating period with an equivalent effective luminous intensity as required by 7.3.5 above.

*Markings*

- 7.4.1 The power source, if independent of the lifeboat's battery system, shall be marked externally with –
  - 7.4.1.1 the manufacturer's name or trade mark;
  - 7.4.1.2 the type and batch number; and
  - 7.4.1.3 the date of manufacture and expiry.
- 7.4.2 If the power source is a chemical pressurised cell it shall be clearly marked with a suitable warning notice.

Other Ships Regulations  
regs 42, 43, 44, 63, 64 and 65

**PART 3 – PARTIALLY ENCLOSED LIFEBOATS**

*General*

- 1.1 Partially enclosed lifeboats shall comply with the requirements of Part 1 and 2 and in addition shall comply with the requirements of this Part.

- 1.2 Every partially enclosed lifeboat shall be provided with effective means of bailing or be automatically self-bailing.

### *Enclosure*

- 2.1 Permanently attached rigid covers shall be provided extending over not less than 20 per cent of the length of the lifeboat from the stem and not less than 20 per cent of the length of the lifeboat from the aftermost part of the lifeboat.
- 2.2 The rigid covers shall form two shelters. The interior height of the shelters shall be sufficient to permit persons easy access to their seats in the bow and stern of the lifeboat.
- 2.3 The rigid covers shall be so arranged that they include windows or translucent panels to admit sufficient daylight to the inside of the lifeboat with the openings or canopies closed so as to make artificial light unnecessary.
- 2.4 The rigid covers shall have railings to provide a secure handhold for persons moving about the exterior of the lifeboat.
- 2.5 Open parts of the lifeboat shall be fitted with a permanently attached foldable canopy so arranged that –
  - 2.5.1 it can be easily erected by not more than 2 persons; and
  - 2.5.2 it is insulated to protect the occupants against cold by means of not less than two layers of material separated by an air gap or other equally efficient means; means shall be provided to prevent accumulation of water in the air gap.
- 2.6 The enclosure formed by the rigid covers and canopy shall be so arranged –
  - 2.6.1 as to allow launching and recovery operations to be performed without any occupant having to leave the enclosure;
  - 2.6.2 that it has entrances at both ends and on each side, provided with efficient adjustable closing arrangements which can be easily and quickly opened and closed from inside or outside so as to permit ventilation but exclude seawater, wind and cold. Means shall be provided for holding the entrances securely in the open and in the closed position;
  - 2.6.3 that with the canopy erected and all entrances closed sufficient air is admitted for the occupants at all times;
  - 2.6.4 that it has means for collecting rainwater;
  - 2.6.5 that the exterior of the rigid covers and canopy and the interior of that part of the lifeboat covered by the canopy is of a highly visible colour. The interior of the shelters shall be of a colour which does not cause discomfort to the occupants; and
  - 2.6.6 that it is possible to row the lifeboat.

### *Communications*

- 3.1 Any radiotelegraph installation or any fixed two-way VHF radiotelephone set required by these Regulations shall be installed in a cabin large enough to accommodate both the equipment and the person using it; except that no separate cabin is required if the construction of the lifeboat provides a sheltered space.

## PART 4 – TOTALLY ENCLOSED LIFEBOATS

### *General*

1. Totally enclosed lifeboats shall comply with the requirements of Parts 1 and 2 of this Schedule and in addition shall comply with the requirements of this Part.

### *Enclosure*

- 2.1 Every totally enclosed lifeboat shall be provided with a rigid watertight enclosure which completely encloses the lifeboat.
- 2.2 The enclosure shall be so arranged that –
  - 2.2.1 it provides shelter for the occupants;
  - 2.2.2 access to the lifeboat is provided by hatches which can be closed to make the lifeboat watertight;
  - 2.2.3 except for free-fall lifeboats, hatches are positioned so as to allow launching and recovery operations to be performed without any occupant having to leave the enclosure;
  - 2.2.4 access hatches are capable of being opened and closed from both inside and outside and are equipped with means to hold them securely in open positions;
  - 2.2.5 except for free-fall lifeboats, it is possible to row the lifeboat;
  - 2.2.6 it is capable, when the lifeboat is in the capsized position with the hatches closed and without significant leakage, of supporting the entire mass of the lifeboat, including all equipment, machinery and its full complement of persons;
  - 2.2.7 it includes windows or translucent panels on both sides which admit sufficient daylight to the inside of the lifeboat with the hatches closed to make artificial light unnecessary;
  - 2.2.8 its exterior is of a highly visible colour and its interior of a colour which does not cause discomfort to the occupants;
  - 2.2.9 handrails provide a secure handhold for persons moving about the exterior of the lifeboat and aid embarkation and disembarkation;
  - 2.2.10 persons have access to their seats from an entrance without having to climb over thwarts or other obstructions; and
  - 2.2.11 the occupants are protected from the effects of dangerous sub-atmospheric pressures which might be created by the lifeboat's engine, during operation of the engine with entrances closed, the atmospheric pressure inside the lifeboat shall never be above the outside atmospheric pressure or fall below it by more than 20 millibar.

### *Capsizing and re-righting*

- 3.1 Except in free-fall lifeboats, a four-point safety belt and head protection shall be fitted at each indicated seating position. The safety belt shall be designed to hold a person of a mass of 100 kilogrammes securely in place when the lifeboat is in a capsized position. Each set of safety

belts for a seat shall be of a colour which contrasts with the belts for seats immediately adjacent. Free-fall lifeboats shall be fitted with a safety harness at each seat in contrasting colour designed to hold a person with a mass of 100 kilogrammes securely in place during a free-fall launch as well as with the lifeboat in capsized position.

- 3.2 The stability of the lifeboat shall be such that it is inherently or automatically self-righting when loaded with its full or partial complement of persons and equipment and all entrances and openings are closed watertight and the persons are secured with safety belts.
- 3.3 The lifeboat shall be capable of supporting its full complement of persons and equipment when the lifeboat is in the damaged condition prescribed in paragraph 3.1 of Part 1 and its stability shall be such that in the event of capsizing, it will automatically attain a position that will provide an above-water escape for its occupants. When the lifeboat is in the stable flooded condition, the water level inside the lifeboat, measured along the seatback, shall not be more than 500 millimetres above the seat pan at any occupant seating position.
- 3.4 The design of all engine exhaust pipes, air ducts and other openings shall be such that water is excluded from the engine when the lifeboat capsizes and re-rights.

### *Propulsion*

- 4.1 The engine and transmission shall be controlled from the helmsman's position.
- 4.2 The engine installation shall be capable of running in any position during capsize and continue to run after the lifeboat returns to the upright or shall automatically stop on capsizing and be easily restarted after the lifeboat returns to the upright. The design of the fuel and lubricating systems shall prevent the loss of fuel and the loss of more than 250 millilitres of lubricating oil from the engine during capsize.
- 4.3 Air-cooled engines shall have a duct system to take in cooling air from, and exhaust it to, the outside of the lifeboat. Manually operated dampers shall be provided to enable cooling air to be taken in from, and exhausted to, the interior of the lifeboat.

### *Construction and fendering*

5. Notwithstanding the requirements of paragraph 3.6 of Part 1, a totally enclosed lifeboat except a free-fall lifeboat shall be so constructed and fendered as to ensure that the lifeboat renders protection to its occupants against harmful accelerations when, loaded with its full complement of persons and equipment, it impacts against the ship's side with a velocity of not less than 3.5 metres per second.

**Other Ships Regulations**  
regs 45 and 66

## **PART 5 – LIFEBOATS WITH A SELF-CONTAINED AIR SUPPORT SYSTEM**

### *General*

- 1.1 Lifeboats with a self-contained air support system shall comply with the requirements of Parts 1, 2 and 4 and if a free-fall lifeboat, comply with Part 9 and in addition shall comply with the requirements of this Part.
- 1.2 Every lifeboat with a self-contained air supply system shall be so arranged that, when proceeding with all entrances and openings closed, the air in the lifeboat remains safe and breathable and the engine runs normally for a period of not less than 10 minutes. During this period the atmospheric pressure inside the lifeboat shall never fall below the outside atmospheric pressure nor shall it exceed it by more than 20 millibar. The system shall have visual indicators to indicate the pressure of the air supply at all times.

## PART 6 – FIRE-PROTECTED LIFEBOATS

### *General*

- 1.1 Fire-protected lifeboats shall comply with the requirements of Parts 1, 2, 4 and 5 and if a free-fall lifeboat, comply with Part 9 and in addition shall comply with the requirements of this Part.
- 1.2 Every fire-protected lifeboat when waterborne shall be capable of protecting the number of persons it is permitted to accommodate when subjected to a continuous oil fire that envelops the lifeboat for a period of not less than 8 minutes.

### *Water spray system*

- 2.1 A lifeboat which has a water spray fire-protection system shall comply with the following –
  - 2.1.1 water for the system shall be drawn from the sea by a self-priming motor pump. It shall be possible to turn on and turn off the flow of water over the exterior of the lifeboat;
  - 2.1.2 the seawater intake shall be so arranged as to prevent the intake of flammable liquids from the sea surface;
  - 2.1.3 the system shall be arranged for flushing with fresh water and allowing complete drainage; and
  - 2.1.4 when an external light is fitted to a fire-protected lifeboat it shall be protected by the water-spray system.

Small Passenger Ship Regulations  
regs 5 and 6

Other Ships Regulations  
regs 42, 43, 44, 45, 47, 48  
63, 64, 65, 66, 68 and 69

## PART 7 – RIGID RESCUE BOATS

### *General*

- 1.1 Rigid rescue boats shall comply with the requirements of Part 1 and in addition shall comply with the requirements of this Part.
- 1.2 A lifeboat may be accepted as a rigid rescue lifeboat provided it also complies with the requirements of this Part and its stowage, launching and recovery arrangements meet all the requirements for a rescue boat.

### *Construction*

- 2.1 The number of persons which a boat shall be permitted to accommodate shall be equal to the lesser of –
  - 2.1.1 the number of persons having an average mass of 75 kilogrammes, all wearing lifejackets, that can be seated in a normal position plus one person lying down on a stretcher without interfering with the means of propulsion or the operation of any of the boat's equipment; or

2.1.2 the number of spaces that can be provided on the seating arrangements in accordance with figure 2, plus one person lying down on a stretcher, seating except for the helmsman may be provided on the floor provided that the seating space analysis uses shapes similar to figure 2 but altered to an overall length of 1190 millimetres to provide for extended legs, no part of a seating space shall be on the gunwale, transom or on inflated buoyancy at the side of a boat.

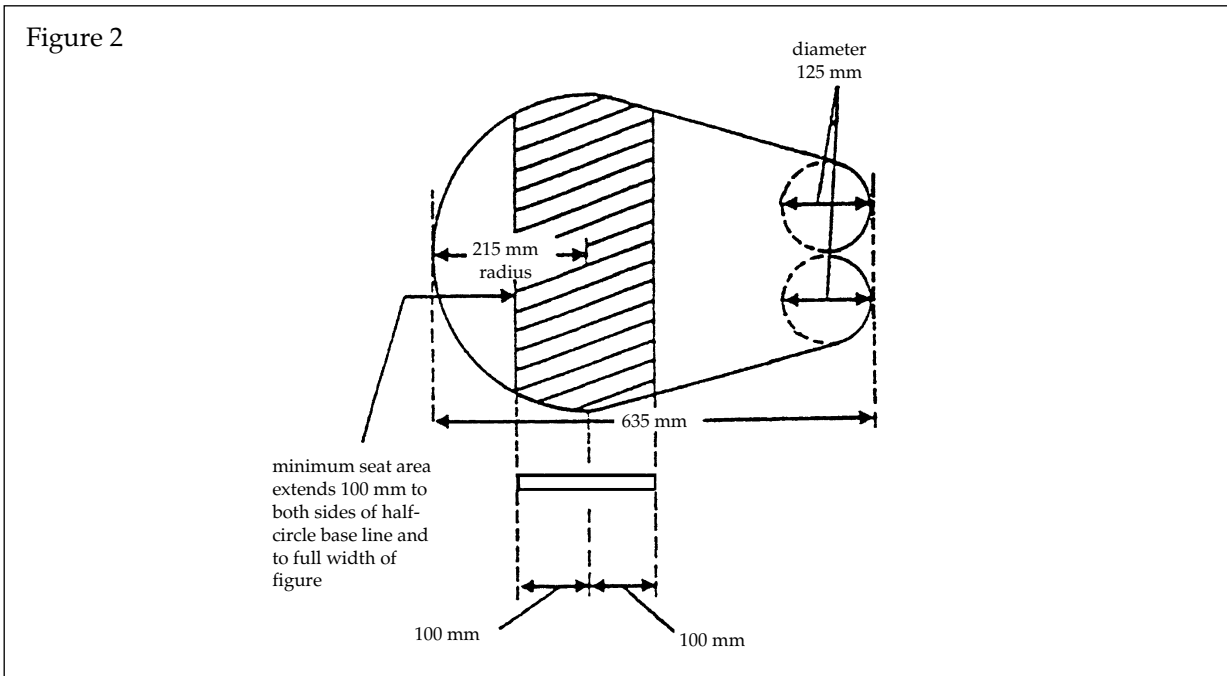

2.2 Boats shall be –

2.2.1 not less than 3.8 metres and not more than 8.5 metres in length; and

2.2.2 capable of carrying at least 5 seated persons and a person lying down.

2.3 Unless the boat has adequate sheer it shall be provided with a bow cover extending for not less than 15 per cent of its length.

2.4 Boats shall be capable of manoeuvring at speeds of at least 6 knots and maintaining a speed of 6 knots for a period of at least 4 hours.

2.5 Boats shall have sufficient mobility and manoeuvrability in a seaway to enable persons to be retrieved from the water, marshal liferafts and tow the largest liferaft carried on the ship when loaded with its full complement of persons and equipment or its equivalent at a speed of at least 2 knots.

2.6 Boats shall be fitted with an inboard or outboard engine complying with the relevant parts of section 3.

2.7 Arrangements for towing shall be permanently fitted and shall be sufficiently strong to marshal or tow liferafts as required by paragraph 2.5.

2.8 Boats shall be fitted with weathertight stowage for small items of equipment.

2.9 Boats shall be fitted with a protective stowage cover and shall be kept covered at all times when the boat is not in use. The cover shall be arranged for quick removal in an emergency.



- 2.10 Unless expressly provided otherwise, every rescue boat shall be provided with effective means of bailing or be automatically self bailing.
- 2.11 Buoyant material for rescue boats may be installed external to the hull, provided it is adequately protected against damage and is capable of withstanding exposure conditions described in Part 8 paragraph 2.6.

### *Propulsion*

- 3.1 Where a boat is powered by an inboard engine it shall be of the compression ignition type complying with the requirements of paragraph 4.1 of Part 1.
- 3.2 Outboard engines using petrol or diesel oil as fuel shall be fitted with approved fuel systems. Petrol storage tanks shall be specially protected against fire and explosion. A starting system, which shall not be impeded by the engine casing, thwarts or other obstructions and which may include starting aids, shall be fitted and be capable of starting the engine –
- 3.2.1 at the ambient temperature and, within 2 minutes of commencing the starting procedure, at an ambient temperature of  $-15^{\circ}\text{C}$ , by manual means; or
- 3.2.2 at the ambient temperature by manual means and, within 2 minutes of commencing the starting procedure, by a powered starting system at an ambient temperature of  $-15^{\circ}\text{C}$ : except that if the ship on which the boat and its engine are carried, is constantly engaged on voyages where a different temperature is appropriate, that temperature may be substituted for  $-15^{\circ}\text{C}$ .

### *Equipment*

- 4.1 All items of rescue boat equipment, with the exception of the boat hook which shall be kept available for fending off purposes, shall be secured within the boat by lashings, storage in lockers or compartments, storage in brackets or similar mounting arrangements, or other suitable means. The equipment shall be secured in such a manner as not to interfere with any launching or recovery procedures. All items of boat equipment shall be as small and of little mass as possible and shall be packed in suitable and compact form.
- 4.2 The equipment of every boat shall consist of –
- 4.2.1 sufficient buoyant oars or paddles to make headway in calm seas; thole pins, crutches or equivalent arrangements shall be provided for each oar; thole pins or crutches shall be attached to the boat by lanyards or chains;
- 4.2.2 a buoyant bailer;
- 4.2.3 a binnacle containing an efficient compass which is luminous or provided with suitable means of illumination;
- 4.2.4 a sea-anchor;
- 4.2.5 a painter of sufficient length and strength, attached to the release device complying with the requirements of paragraph 5.6 of Part 1 and placed at the forward end of the boat;
- 4.2.6 one buoyant line, not less than 50 metres in length, of sufficient strength to tow a liferaft as required by paragraph 2.5;
- 4.2.7 one waterproof electric torch suitable for Morse signalling, together with one spare set of batteries and one spare bulb in a waterproof container;

- 4.2.8 one whistle or equivalent sound signal;
- 4.2.9 a first-aid outfit complying with the requirements of Schedule 13;
- 4.2.10 two buoyant rescue quoits, attached to not less than 30 metres of buoyant line with a breaking strain of at least 1.0 kilonewton;
- 4.2.11 a searchlight with a horizontal and vertical sector of at least 6 degrees and a measured luminous intensity of 2500 candela which can work continuously for not less than 3 hours;
- 4.2.12 an efficient radar reflector;
- 4.2.13 thermal protective aids sufficient for 10 per cent of the number of persons the rescue boat is permitted to accommodate, or two, whichever is greater;
- 4.2.14 a boat hook;
- 4.2.15 a bucket;
- 4.2.16 a knife or hatchet;
- 4.2.17 a portable fire extinguisher suitable for extinguishing oil fires; and
- 4.2.18 a manually controlled lamp complying with the requirement of Part 2 Section 6.

In passenger ships of Classes III to VI(A) the equipment specified in paragraphs 4.2.3, 4.2.11, 4.2.12 and 4.2.13 need not be provided.

#### *Access into boats*

- 5.1 Every passenger ship rigid rescue boat shall be so arranged that it can be rapidly boarded by its rescue complement of persons. Rapid disembarkation shall also be possible.
- 5.2 Every cargo ship rigid rescue boat shall be so arranged that it can be boarded by its rescue complement of persons in not more than 3 minutes from the time the instruction is given. Rapid disembarkation shall also be possible.

**Small Passenger Ship Regulations**  
regs 5 and 6

**Other Ships Regulations**  
regs 42, 43, 44, 45, 47, 48  
63, 64, 65, 66, 68 and 69

## **PART 8 – RIGID INFLATED RESCUE BOATS**

### *General*

- 1.1 A rigid inflated rescue boat is a composite craft combining a rigid lower hull and inflated tubes fitted at the edge of the lower hull forming a watertight boundary.
- 1.2 Rigid inflated rescue boats shall comply with all the requirements of Part 1 with the exception of paragraph 3.11, and with Part 7 with the exception of paragraph 1.2, and in addition with the requirements of this Part.

### *Construction*

- 2.1 The buoyancy of the boat shall be a combination of inherent and inflated buoyancy.
- 2.2 The inflated buoyancy tube shall be a single tube sub-divided into at least five separate compartments of approximately equal volume.

- 2.3 Boats shall have adequate inherent buoyancy or inherently buoyant material together with the inflatable compartments on one side (excluding the forward compartment) when inflated, sufficient to float the boat with all its equipment on board when flooded and open to the sea.
- 2.4 Additional inherent buoyancy equal to 140 newtons of buoyancy force per person shall be provided for the number of persons the boat is permitted to accommodate. This additional buoyancy may be installed externally to the rigid hull of the boat provided it is adequately protected against damage and is capable of withstanding exposure conditions described in paragraph 2.6.
- 2.5 Inherently buoyant material shall not be adversely affected by seawater, oil or oil products.
- 2.6 Boats shall be so constructed as to be capable of withstanding exposure –
  - 2.6.1 when stowed on an open deck on a ship at sea;
  - 2.6.2 for 30 days afloat in all sea conditions.
- 2.7 The buoyancy tubes forming the boundary of the boat shall on inflation provide a volume of not less than 0.17 cubic metres for each person the boat is permitted to accommodate and the diameter of the main buoyancy chamber must be at least 0.43 metres.
- 2.8 Each buoyancy compartment shall be fitted with a non-return valve for manual inflation and means for deflation. A safety relief valve shall also be fitted to each buoyancy compartment.
- 2.9 The inflated buoyancy tubes shall be maintained at all times in a fully inflated condition.

#### *Markings*

- 3. If any of the markings required by section 6 of Part 1 are marked on the buoyancy tubes, the materials used to mark them shall be of a type which is compatible with the boat's coated fabric and approved by the boat manufacturer.

#### *Equipment*

- 4. In addition to the equipment required by section 4.2 of Part 7 the following items are required –
  - 4.1. an efficient manually operated bellows or pump; and
  - 4.2. a repair kit in a suitable container for repairing punctures to the coated fabric of the buoyancy tubes.

Other Ships Regulations  
regs 65 and 66

### **PART 9 – FREE-FALL LIFEBOATS**

#### *General*

- 1. Free-fall lifeboats shall comply with the requirements of Part 4 and in addition shall comply with the requirements of this Part.

#### *Carrying capacity of a free-fall lifeboat*

- 2. The carrying capacity of a free-fall lifeboat is the number of persons that can be provided with a seat without interfering with the means of propulsion or the operation of any of the lifeboat's equipment.

The width of the seat shall be at least 430 millimetres. Free clearance in front of the backrest shall be at least 635 millimetres. The backrest shall extend at least 1,000 millimetres above the seatpan.

### *Performance requirements*

- 3.1 Each free-fall lifeboat shall make positive headway immediately after water entry and shall not come into contact with the ship after a free-fall launching against a trim of up to 10 degrees and a list of up to 20 degrees either way from the certification height when fully equipped and loaded with:
  - 3.1.1 its full complement of persons;
  - 3.1.2 occupants so as to cause the centre of gravity to be in the most forward position;
  - 3.1.3 occupants so as to cause the centre of gravity to be in the most aft position, and
  - 3.1.4 its operating crew only.
- 3.2 For oil tankers, chemical tankers and gas carriers with a final angle of heel greater than 20 degrees calculated in accordance with the requirements of Part 1, Schedule 6, paragraph 1.2, as applicable, a lifeboat shall be capable of being free-fall launched at the final angle of heel and on the base of the final waterline of that calculation.
- 3.3 The required free-fall height shall never exceed the free-fall certification height.

### *Construction*

4. Each free-fall lifeboat shall be of sufficient strength to withstand, when loaded with its full complement of persons and equipment, a free-fall launch from a height of at least 1.3 times the free-fall certification height.

### *Protection against harmful acceleration*

- 5.1 Each free-fall lifeboat shall be so constructed as to ensure that the lifeboat is capable of rendering protection resulting from being launched from the height for which it is to be certified in calm water under unfavourable conditions of trim up to 10 degrees and list of up to 20 degrees either way when it is fully equipped and loaded with:
  - 5.1.1 its full complement of persons;
  - 5.1.2 one half of its full complement of persons distributed so as to cause the centre of gravity to be in the most forward position;
  - 5.1.3 one half of its full complement of persons distributed so as to cause the centre of gravity to be in the most aft position; and
  - 5.1.4 the operating crew only.

### *Lifeboat fittings*

- 6.1 Each free-fall lifeboat shall be fitted with a release system which shall:
  - 6.1.1 have two independent activation systems for the release mechanisms which may only be operated from inside the lifeboat and be marked in a colour that contrasts with its surroundings;
  - 6.1.2 be so arranged as to release the boat under any condition of loading from no load up to at least 200 per cent of the normal load caused by the fully equipped lifeboat when loaded with the number of persons for which it is to be approved;

- 6.1.3 be adequately protected against accidental or premature use;
- 6.1.4 be designed to test the release system without launching the lifeboat; and
- 6.1.5 be designed with a factor of safety of 6 based on the ultimate strength of the materials used.

*Certificate of approval*

- 7.1 In addition to the requirements of this Schedule, Part 1, paragraph 6.1 the certificate of approval for a free-fall lifeboat shall also state:
  - 7.1.1 free-fall certification height;
  - 7.1.2 required launching ramp length; and
  - 7.1.3 launching ramp angle for the free-fall certification height.

**Other Ships Regulations**  
regs 7, 8, 9, 63 and 64

**PART 10 – FAST RESCUE BOATS, RIGID AND RIGID INFLATED**

**General**

- 1.1 Except as provided by this Part all fast rescue boats shall comply with the applicable requirements of:
  - 1.1.1 rigid rescue boats – Part 7; and
  - 1.1.2 rigid inflated rescue boats – Part 8 and with the following requirements.
- 1.2 Fast rescue boats shall be not less than 6 metres in length and not more than 8 metres.
- 1.3 Fast rescue boats shall be capable of manoeuvring, for at least 4 hours, at a speed of at least 20 knots in calm water with a suitably qualified crew of 3 persons and at least 8 knots with a full complement of persons and equipment.
- 1.4 Fast rescue boats shall be self-righting or capable of being readily righted by their crew.
- 1.5 Fast rescue boats shall be self-bailing or be capable of being rapidly cleared of water.
- 1.6 Fast rescue boats shall be steered by a wheel at a helmsman's position remote from the tiller. An emergency steering system providing direct control of the rudder, water jet, or outboard motor shall also be provided.
- 1.7 Engines in fast rescue boats shall stop automatically or be stopped by the helmsman's emergency release switch should the rescue boat capsize. When the rescue boat has righted, each engine or motor should be capable of being restarted, provided the helmsman's emergency release, if fitted, has been reset. The design of the fuel and lubricating systems shall prevent the loss of more than 250 ml of fuel or lubricating oil from the propulsion system should the rescue boat capsize.
- 1.8 Fast rescue boats shall, if possible, be equipped with an easily operated fixed single-point suspension arrangement or equivalent.

### SCHEDULE 3

## INFLATED RESCUE BOATS AND INFLATED BOATS

### PART 1 – GENERAL

#### *General*

- 1.1 Inflated rescue boats and inflated boats are craft combining a flexible lower hull and inflated tubes fitted at the edge of the lower hull, together with forming a watertight boundary and which rely solely on the buoyancy of the inflated tubes as the inherent buoyancy of the craft.
- 1.2 Inflated rescue boats and inflated boats shall comply with the requirements of Schedule 1 and of this Part.

#### *Construction*

- 2.1 Boats shall be properly constructed and be of such form and proportion that they have ample stability in a seaway and sufficient freeboard when loaded with their full complement of persons and equipment. Boats shall be capable of maintaining positive stability in an upright position in calm water when loaded with their full complement of persons and equipment and fully swamped.
- 2.2 Each boat shall be of sufficient strength to withstand, when loaded with its full complement of persons and equipment and with, where applicable, skates or fenders in position, a lateral impact against the ship's side at an impact velocity of at least 3.5 metres per second and also a drop into the water from a height of at least 3 metres.
- 2.3 The number of persons which a boat shall be permitted to accommodate shall be equal to the lesser of –
- 2.3.1 The number of persons having an average mass of 75 kilogrammes, all wearing lifejackets, that can be seated inboard of the buoyancy tubes in a normal position plus one person lying down without interfering with the means of propulsion or the operation of any of the boat's equipment; or
- 2.3.2 the number of spaces that can be provided on the seating arrangements in accordance with figure 2 in Part 7 of Schedule 2 plus one person lying down on a stretcher. Seating, except for the helmsman, may be provided on the floor provided that the seating space analysis uses shapes similar to figure 2 in Part 7 but altered to an overall length of 1190 millimetres to provide for extended legs, no part of a seating space shall be on the gunwale, transom or on inflated buoyancy at the sides of the boat.
- 2.4 Each seating position shall be clearly indicated in the boat.
- 2.5 Boats shall have a boarding ladder that can be used on either side of the boat to enable persons in the water to board the boat. The lowest step of the ladder shall be weighted and float at a level not less than 0.4 metres below the boat's light waterline.
- 2.6 The boat shall be so arranged that helpless people can be brought on board either from the sea or on stretchers.

- 2.7** Surfaces on which persons might walk shall have a non-skid finish.
- 2.8** Boats, when loaded with 50 per cent of the number of persons they are permitted to accommodate seated in their normal positions to one side of the centreline, shall have a freeboard measured from the waterline to the lowest opening through which the boat may become flooded, of at least 1.5 per cent of the boat's length or 100 millimetres, whichever is the greater.
- 2.9** Boats without adequate sheer, shall be provided with a bow cover of highly visible colour extending for not less than 15 per cent of their length and angled upwards to deflect water and spray.
- 2.10** Boats shall have sufficient mobility and manoeuvrability in a seaway to enable persons to be retrieved from the water, marshal liferafts and tow the largest liferaft carried on the ship, when loaded with their full complement of persons and equipment, or its equivalent, at a speed of at least 2 knots.
- 2.11** Arrangements for towing shall be permanently fitted in boats and shall be sufficiently strong to marshal or tow liferafts as required by paragraph 2.10.
- 2.12** Boats shall be fitted with weathertight stowage for small items of equipment.
- 2.13** A boat shall be so constructed as to be capable of withstanding exposure –
- 2.13.1** when stowed on an open deck on a ship at sea; and
- 2.13.2** for 30 days afloat in all sea conditions.
- 2.14** Buoyancy shall be provided by either a single tube subdivided into at least five separate compartments of approximately equal volume or two separate tubes neither exceeding 60 per cent of the total volume. Buoyancy tubes shall be so arranged that, in the event of any one of the compartments being damaged, the intact compartments shall be able to support, with positive freeboard over the boat's entire periphery, the number of persons which the boat is permitted to accommodate, each having a mass of 75 kilogrammes, and seated in their normal positions under the following conditions:
- 2.14.1** with the forward buoyancy compartment deflated;
- 2.14.2** with the entire buoyancy on one side of the rescue boat deflated; and
- 2.14.3** with the entire buoyancy on one side and the bow compartment deflated.
- 2.15** Buoyancy tubes forming the boundary of the boat shall on inflation provide a volume of not less than 0.17 cubic metres for each person the boat is permitted to accommodate and the diameter of the main buoyancy chamber must be at least 0.43 metres.
- 2.16** Each buoyancy compartment shall be fitted with a non-return valve for manual inflation and means for deflation. A safety relief valve shall also be fitted to each buoyancy compartment which in the case of an inflated boat shall be designed to operate at a pressure not exceeding 125 per cent of the designed working pressure of the buoyancy chamber.
- 2.17** When inverted in the water a boat shall be capable of being righted by not more than 2 persons.
- 2.18** Rubbing strips shall be provided underneath the bottom and on vulnerable places on the outside of the boat.

- 2.19 Where a transom is fitted it shall not be inset by more than 20 per cent of the overall length of the boat.
- 2.20 Suitable patches shall be provided for securing painters forward and aft and becketed lifelines inside and outside the boat.
- 2.21 Boats shall be maintained at all times in a fully inflated condition.
- 2.22 Boats shall be fitted with a protective stowage cover and shall be kept covered at all times when not in use. The cover shall be arranged for quick removal in an emergency.

### *Propulsion*

- 3.1 Unless the propeller is so arranged so as to avoid its rotation constituting a danger to people in the water adjacent to it the drive arrangement between the prime mover and the propeller shall be such that the propeller can be brought to rest without stopping the prime mover. Provision shall be made for ahead and astern propulsion of the craft.
- 3.2 The exhaust pipe shall be so arranged as to prevent water from entering the engine in normal operation.
- 3.3 Boats shall be designed with due regard to the safety of persons in the water and to the possibility of damage to the propulsion system by floating debris.
- 3.4 The boat engine and accessories shall be designed to limit electromagnetic emissions so that engine operation does not interfere with the operation of radio life-saving appliances used in the boat.
- 3.5 Water-resistant instructions for starting and operating the engine shall be provided and mounted in a conspicuous place near the engine starting controls.

### *Fittings*

- 4.1 Boats shall be provided with at least one drain valve fitted near the lowest point in the hull, which shall automatically open to drain water from the hull when the boat is not waterborne and shall automatically close to prevent entry of water when the boat is waterborne. Each drain valve shall be provided with a cap or plug to close the valve, which shall be readily attached to the boat by a lanyard, chain, or other suitable means. Drain valves shall be readily accessible and capable of being closed from inside the boat and their position shall be clearly indicated.
- 4.2 Boats which are not self-righting when capsized shall have suitable handholds on the underside of the hull to enable persons to cling to the boat. The handholds shall be fastened to the boat in such a way that, when subjected to an impact sufficient to cause them to break away from the boat, they break away without damaging the boat.
- 4.3 Every boat to be launched by a fall or falls shall be fitted with a release mechanism complying with section 8, Part 1 of Schedule 2 except those which are launched by a single suspension which may have an approved release mechanism which is operable when the boat is waterborne.
- 4.4 Unless expressly provided otherwise, every boat shall be provided with effective means of bailing or be automatically self-bailing.



## *Markings*

- 5.1 The dimensions of the boat, the number of persons which it is permitted to accommodate, the maker's serial number, name or trade mark and the date of manufacture shall be marked on the boat in clear permanent characters.
- 5.2 The name and port of registry of the ship to which the boat belongs shall be marked on each side of the boat's bow in block capitals.
- 5.3 Means of identifying the ship to which the boat belongs and the number of the boat shall be marked in such a way that they are visible from above.
- 5.4 All materials used to mark a boat shall be of a type which is compatible with the boat's coated fabric and approved by the boat manufacturer.

## *Equipment*

- 6.1 All items of boat equipment, with the exception of the boat-hook which shall be kept available for fending off purposes, shall be secured within the boat by lashings, storage lockers or compartments, storage in brackets or similar mounting arrangements, or other suitable means. The equipment shall be secured in such a manner as not to interfere with any launching or recovery procedures. All items of boat equipment shall be as small and of as little mass as possible and shall be packed in suitable and compact form.
- 6.2 The equipment of every boat shall consist of –
  - 6.2.1 a buoyant bailer;
  - 6.2.2 a sea-anchor;
  - 6.2.3 one buoyant line, not less than 50 metres in length, of sufficient strength to tow a liferaft as required by paragraph 2.10;
  - 6.2.4 one waterproof electric torch suitable for Morse signalling, together with one spare set of batteries and one spare bulb in a waterproof container;
  - 6.2.5 one whistle or equivalent sound signal;
  - 6.2.6 a first-aid outfit complying with the requirements of Schedule 13;
  - 6.2.7 two buoyant rescue quoits, attached to not less than 30 metres of buoyant line with a breaking strain of at least 1.0 kilonewtons;
  - 6.2.8 a buoyant safety knife;
  - 6.2.9 two sponges;
  - 6.2.10 an efficient manually operated bellows or pump;
  - 6.2.11 a puncture repair kit in a suitable container;
  - 6.2.12 a safety boat hook;
  - 6.2.13 a portable fire extinguisher suitable for extinguishing oil fires; and
  - 6.2.14 a manually controlled lamp complying with the requirements of Part 2, Section 7.

## *Instructions and Information*

- 7.1 Instructions and information required for inclusion in the training manual and in the instructions for on-board maintenance specified in Schedule 14 shall be in a form suitable for inclusion in such training manual and instructions for on-board maintenance. Instructions and information shall be in English in a clear and concise form and shall include, as appropriate, the following –
- 7.1.1 a general description of the boat and its equipment;
  - 7.1.2 the installation arrangements;
  - 7.1.3 operational instructions including use of associated survival equipment;
  - 7.1.4 survival instructions;
  - 7.1.5 emergency repair instructions;
  - 7.1.6 deployment, boarding and launching instructions;
  - 7.1.7 the method of launching from within the boat;
  - 7.1.8 the release from launching appliance;
  - 7.1.9 on-board maintenance requirements;
  - 7.1.10 servicing requirements;
  - 7.1.11 the use of engine and accessories; and
  - 7.1.12 the recovery of boat including stowage and securing.

Small Passenger Ship Regulations  
regs 5 and 6

Other Ships Regulations  
regs 42, 43, 44, 45, 47, 48  
63, 64, 65, 66, 68 and 69

## **PART 2 – INFLATED RESCUE BOAT**

### *General*

1. Inflated rescue boats shall comply with the requirements of Part 1 and in addition with the requirements of this Part.

### *Construction*

- 2.1 Boats shall be of sufficient strength to –
  - 2.1.1 enable them to be safely lowered into the water when loaded with their full complement of persons and equipment; and
  - 2.1.2 be capable of being launched and towed when the ship is making headway at a speed of 5 knots in calm water.
- 2.2 An inflated rescue boat shall be constructed in such a way that, when suspended by its bridle or lifting hook –

- 2.2.1 it is of sufficient strength and rigidity to enable it to be lowered and recovered with its full complement of persons and equipment;
  - 2.2.2 it is of sufficient strength to withstand a load of 1.1 times the mass of its full complement of persons and equipment at an ambient temperature of  $-30^{\circ}\text{C}$  with all relief valves operative; and
  - 2.2.3 it is of sufficient strength to withstand a load of 4 times the mass of its full complement of persons and equipment at an ambient temperature of  $20\pm 3^{\circ}\text{C}$  with all relief valves inoperative.
- 2.3 Seating shall be provided on thwarts, benches or fixed chairs fitted as low as practicable in the boat and constructed so as to be capable of supporting the number of persons each weighing 100 kilogrammes for which spaces are provided in compliance with the requirements of paragraph 2.3.2 of Part 1.
- 2.4 Boats shall –
- 2.4.1 be not less than 3.8 metres and not more than 8.5 metres in length; and
  - 2.4.2 be capable of carrying at least 5 seated persons and a person lying down on a stretcher.
- 2.5 Boats shall be capable of manoeuvring at speeds of at least 6 knots and maintaining a speed of 6 knots for a period of at least 4 hours.
- 2.6 Boats shall be fitted with an inboard or outboard engine complying with the relevant parts of section 3 below.

### *Propulsion*

#### *Inboard engine*

- 3.1 Where a boat is powered by an inboard engine it shall be of the compression ignition type. No engine shall be used for any boat if its fuel has a flashpoint of  $43^{\circ}\text{C}$  or less (Closed Cup Test), and the engine shall –
- 3.1.1 be provided with either a manual starting system, or a power starting system with two independent rechargeable energy sources. Any necessary starting aids shall also be provided; the engine starting systems and starting aids shall start the engine at an ambient temperature of  $-15^{\circ}\text{C}$  within 2 minutes of commencing the start procedure unless, having regard to the particular voyages in which the ship carrying the boat is constantly engaged, a different temperature is appropriate; the starting systems shall not be impeded by the engine casing, thwarts or other obstructions;
  - 3.1.2 be capable of operating for not less than 5 minutes after starting from cold with the boat out of the water;
  - 3.1.3 be capable of operating when the boat is flooded up to the centreline of the crank shaft.

#### *Outboard engine*

- 3.2 Outboard engines using petrol or diesel oil as fuel shall be fitted with approved fuel systems. Petrol storage tanks shall be specially protected against fire and explosion. A starting system, which shall not be impeded by the engine casing, thwarts or other obstructions and which may include starting aids, shall be fitted and be capable of starting the engine –

- 3.2.1 at the ambient temperature and, within 2 minutes of commencing the starting procedure, at an ambient temperature of  $-15^{\circ}\text{C}$ , by manual means; or
- 3.2.2 at the ambient temperature by manual means and, within 2 minutes of commencing the starting procedure, by a powered starting system at an ambient temperature of  $-15^{\circ}\text{C}$ : except that if the ship on which the boat and its engine are carried, is constantly engaged on voyages where a different temperature is appropriate, that temperature may be substituted for  $-15^{\circ}\text{C}$ .
- 3.3 The boat engine, transmission and engine accessories shall be enclosed in a fire-retardant casing or other suitable arrangements providing similar protection. Such arrangements shall also protect persons from coming into accidental contact with hot or moving parts and protect the engine from exposure to weather and sea. Adequate means shall be provided to reduce the engine noise. Starter batteries shall be provided with casings which form a watertight enclosure around the bottom and sides of the batteries. Battery casings shall have tight fitting tops which provide for necessary gas venting.
- 3.4 Means shall be provided for recharging all engine-starting, searchlight and, when fitted, radio batteries. Radio batteries shall not be used to provide power for engine starting. Means shall be provided for recharging rescue boat batteries from the ship's power supply. The electric power supply connection from the ship to any inflated rescue boat shall be at a voltage not exceeding 55 volts direct current or 55 volts root mean square alternating current and shall be capable of being disconnected automatically at the inflated rescue boat embarkation station.

### *Fittings*

- 4.1 Boats shall be provided with a rudder and tiller or other suitable means of steering. When a wheel or other remote steering mechanism is also provided the alternative means shall be capable of steering the boat in the case of failure of the steering mechanism. Except where the rudder forms part of an outboard engine a rudder shall be permanently attached to the boat and a tiller shall be permanently installed on or linked to the rudder stock. However, if the boat has a remote steering mechanism the tiller may be removable and securely stowed near the rudder stock. The steering arrangements shall be so arranged so not to be damaged by operation of the release mechanism or the propeller.
- 4.2 Except in the vicinity of the rudder and propeller, a buoyant lifeline shall be becketed around the inside and outside of the boat.
- 4.3 Every boat shall be fitted with a release device to enable the forward painter to be released when under tension.
- 4.4 Boats intended for launching down the side of a ship shall have skates and fenders as necessary to facilitate launching and prevent damage to the boat.

### *Equipment*

- 5.1 In addition to the equipment required under Part 1 every inflated rescue boat shall be provided with –
- 5.1.1 sufficient buoyant oars or paddles to make headway in calm seas; thole pins, crutches or equivalent arrangements shall be provided for each oar; thole pins or crutches shall be attached to the boat by lanyards or chains;
- 5.1.2 a binnacle containing an efficient compass which is luminous or provided with suitable means of illumination;

- 5.1.3 a painter of sufficient length and strength, attached to the release device complying with the requirements of paragraph 4.3 and placed at the forward end of the boat;
  - 5.1.4 a searchlight with a horizontal and vertical sector of at least 6 degrees and a measured luminous intensity of 2500 candela which can work continuously for 3 hours;
  - 5.1.5 an efficient radar reflector;
  - 5.1.6 thermal protective aids sufficient for 10 per cent of the number of persons the boat is permitted to accommodate or two whichever is the greater; and
  - 5.1.7 a manually controlled lamp complying with the requirements of Part 2, paragraph 7.
- 5.2 Every cargo ship inflated rescue boat shall be so arranged that it can be boarded by its rescue complement of persons in not more than 3 minutes from the time the instruction to board is given. Rapid disembarkation shall also be possible.

*Access into boats*

- 6.1 In every passenger ship the boats shall be so arranged that they can be rapidly boarded by their rescue complement of persons. Rapid disembarkation shall also be possible.
- 6.2 In every cargo ship the boats shall be so arranged that they can be boarded by their rescue complement of persons in not more than 3 minutes from the time the instruction to board is given. Rapid disembarkation shall also be possible.

*Disengaging Gears*

- 7. Disengaging gear for inflated rescue boats shall comply with the requirements of section 8, Part 1 of Schedule 2.

Small Passenger Ship Regulations  
regs 5 and 6

Other Ships Regulations  
regs 44, 45, 47, 48  
65, 66, 68 and 69

**PART 3 – INFLATED BOATS  
(NON-SOLAS)**

*General*

- 1. Inflated boats shall comply with the requirements of Part 1 and in addition with the requirements of this Part.

*Construction*

- 2.1 A boat shall be constructed in such a way that, when suspended by its bridle or lifting hook
  - 2.1.1 it is of sufficient strength and rigidity to enable it to be lowered and recovered with all its equipment and a crew of 2 persons;
  - 2.1.2 it is of sufficient strength to withstand a load of 1.1 times the mass of its equipment and a crew of 2 persons at an ambient temperature of  $-30^{\circ}\text{C}$  with relief valves operative; and
  - 2.1.3 it is of sufficient strength to withstand a load of 4 times the mass of its equipment and a crew of 2 persons at an ambient temperature of  $20\pm 3^{\circ}\text{C}$  with all relief valves inoperative.

- 2.2 Boats shall be of sufficient strength to enable them to be safely lowered into the water when loaded with all their equipment and a crew of 2 persons.
- 2.3 At least one portable thwart shall be fitted to enable the boat to be rowed satisfactorily.
- 2.4 A boat shall –
  - 2.4.1 be not less than 3.8 metres and not more than 8.5 metres in length; and
  - 2.4.2 be capable of carrying at least 3 persons and a person lying down on a stretcher.
- 2.5 Boats shall be capable of manoeuvring at speeds of at least 6 knots in calm water with 2 persons on board and maintaining a speed of 6 knots for a period of at least 2 hours.
- 2.6 The boat shall be fitted with an outboard engine having a maximum power of 10 horsepower complying with the requirements of section 3.

### *Propulsion*

- 3.1 A petrol-driven outboard engine with an approved fuel system may be fitted, provided the tank is specially protected against fire and explosion.
- 3.2 A petrol engine shall be provided with a manual starting system. The engine starting system shall start the engine at an ambient temperature of  $-15^{\circ}\text{C}$  within 2 minutes of commencing the start procedure. The starting system shall not be impeded by the engine casing, thwarts or other obstructions.

### *Fittings*

- 4. Except in the vicinity of an outboard engine, a buoyant lifeline shall be becketed around the inside and outside of the boat.

### *Lifting Arrangements*

- 5.1 Bridle slinging arrangements shall be fitted to enable the boat to be lowered or raised from the water. The bridle sling shall comprise of at least four legs which should be joined at the top in the form of an eye or be connected to a lifting ring or shackle. The arrangement shall be such that the boat is stable when suspended and either –
  - 5.1.1 the length of the legs are of equal length; or
  - 5.1.2 the bridle is permanently attached; or
  - 5.1.3 it is not possible to connect any of the bridle legs to the wrong position in the boat.
- 5.2 The bridle shall be manufactured of a material which will not adversely affect the material of the boat and, if necessary, shall be sheathed to prevent abrasion of the fabric.
- 5.3 The forward lifting attachments shall be securely fastened to the hull and may be bands passing under the hull to the tops of the buoyancy tubes terminating in “D” rings or eyes to take bridle slings.
- 5.4 The after lifting attachments shall be similar to the forward attachments or may be made directly to the transom.
- 5.5 The bridle slinging arrangements used for lowering and recovering the boat shall be such that the breaking tensile strength is at least 6 times the sum of the mass of the boat, its full equipment and a crew of 2 persons each having a mass of 75 kilogrammes.

- 5.6** The bridle sling lifting arrangements shall be proof tested to not less than 4 times their respective working loads. The proof testing can be carried out either –
- 5.6.1** individually on each item associated with the lifting arrangements; or
  - 5.6.2** on the assembly of a structurally completed boat with its lifting arrangements and particular bridle sling. In each case, fabric webbings and cordages forming part of the lifting arrangements shall have a breaking strength of not less than 6 times their respective working loads.

### **Equipment**

- 6.** In addition to the equipment required by Part 1, every inflated boat shall be provided with –
- 6.1** at least two buoyant oars or paddles to make headway in calm seas; crutches or equivalent arrangements shall be provided for each oar and shall be permanently attached to the boat.
  - 6.2** a painter 20 metres in length; and
  - 6.3** thermal protective aids sufficient for 10 per cent of the number of persons the boat is permitted to accommodate or two, whichever is greater.

In boats on passenger ships of Classes III to VI(A) the equipment specified in paragraph 6.3 need not be provided.

## SCHEDULE 4

### LIFERAFTS

#### PART 1 – GENERAL

##### *General*

1. Inflatable liferafts and rigid liferafts shall comply with the requirements of Schedule 1 and in addition shall comply with the requirements of this Part.

##### *Construction*

- 2.1 Every liferaft shall be so constructed as to be capable of withstanding exposure for 30 days afloat in all sea conditions without such deterioration as would involve any loss of seaworthiness.
- 2.2 The liferaft shall be so constructed that when it is dropped into the water in its container from a height of 18 metres, the liferaft and its equipment will operate satisfactorily. If the liferaft is to be stowed at a height of more than 18 metres above the waterline in the lightest seagoing condition, it shall be of a type which has been satisfactorily drop-tested from at least that height.
- 2.3 The floating liferaft shall be capable of withstanding repeated jumps on to it from a height of at least 4.5 metres above its floor both with and without the canopy erected.
- 2.4 The liferaft and its fittings shall be so constructed as to enable it to be towed at a speed of 3 knots in calm water when loaded with its full complement of persons and equipment and with one of its sea-anchors streamed.
- 2.5 The liferaft shall have a canopy to protect the occupants from exposure which is automatically set in place when the liferaft is launched and waterborne. The canopy shall comply with the following –
  - 2.5.1 it shall provide insulation against heat and cold by means of either two layers of material separated by an air gap or other equally efficient means; means shall be provided to prevent accumulation of water in the air gap;
  - 2.5.2 its interior shall be of a colour that does not cause discomfort to the occupants;
  - 2.5.3 each entrance shall be clearly indicated and be provided with efficient adjustable closing arrangements which can be easily and quickly opened from inside and outside the liferaft so as to permit ventilation but exclude seawater, wind and cold; liferafts accommodating more than 8 persons shall have at least two diametrically opposite entrances;
  - 2.5.4 it shall admit sufficient air for the occupants at all times, even with the entrances closed;
  - 2.5.5 it shall be provided with at least one viewing port if the liferaft is to accommodate less than 25 persons and at least two diametrically opposite viewing ports if it is to accommodate more than 25 persons;



- 2.5.6 it shall be provided with means for collecting rain water;
- 2.5.7 it shall have sufficient headroom for seated occupants under all parts of the canopy;  
and
- 2.5.8 it shall be provided with means to mount a survival craft radar transponder at a height of at least one metre above the sea.
- 2.6 No liferaft shall be approved which has a carrying capacity of less than 6 persons calculated in accordance with the requirements of paragraph 2.5 of Part 2 and of paragraph 2.2 of Part 3: except that in ships of Classes VIII(A), VIII(A)(T) and XI, in ships of Classes VIII and VIII(T) of less than 500 tons, in ships of class IX not being ships of 500 tons or over engaged on an international voyage and in ships of Class XII of 21.3 metres in length or over, the minimum carrying capacity of liferafts may be 4 persons, if the total number of persons on board is less than 5.
- 2.7 Unless the liferaft is to be launched by an approved launching appliance complying with the requirements of Part 3 of Schedule 6 or is not required to be stowed in a position providing for easy side to side transfer, and not required to be portable, the total mass of the liferaft, its container and its equipment shall not be more than 185 kilogrammes.

### *Fittings*

- 3.1 Lifelines shall be securely becketed around the inside and outside of the liferaft.
- 3.2 The liferaft shall be provided with arrangements for adequately siting and securing in the operating position the antenna provided with the portable radio apparatus where this is to be carried.
- 3.3 The liferaft shall be fitted with an efficient painter of length not less than 10 metres plus the distance from the stowed position to the waterline in the lightest seagoing condition, or 15 metres whichever is the greater.
- 3.4 The breaking strength of the painter system including its means of attachment to the liferaft except the weak link required by Part 8 shall be –
- 3.4.1 7.5 kilonewtons for liferafts accommodating up to 8 persons;
- 3.4.2 10.0 kilonewtons for liferafts accommodating 9 to 25 persons; and
- 3.4.3 15.0 kilonewtons for liferafts accommodating more than 25 persons or have a factor of safety of 3 in association with the requirement of paragraph 2.4 above whichever is the greater.
- 3.5 Entrances not provided with a boarding ramp shall have a boarding ladder, the lowest step of which shall be weighted and float at a level not less than 0.4 metres below the liferaft's light waterline.
- 3.6 There shall be means inside the liferaft to assist persons to pull themselves into the liferaft from the ladder.
- 3.7 The stability of the liferaft when loaded with its full complement of persons and equipment shall be such that it can be towed at speeds of up to 3 knots in calm water.
- 3.8 At least one manually controlled lamp complying with the requirements of Part 9 shall be fitted outside at the top of the liferaft canopy.

- 3.9 A manually controlled lamp complying with the requirements of Part 9 shall be fitted inside the liferaft.
- 3.10 Each inflatable liferaft shall be fitted with equipment complying with the relevant requirements of Part 6.

#### *Markings*

- 4.1 The liferaft shall be marked with the –
- 4.1.1 maker's name or trade mark;
  - 4.1.2 serial number;
  - 4.1.3 date of manufacture (month and year);
  - 4.1.4 name and place of servicing station where it was last serviced; and
  - 4.1.5 number of persons it is permitted to accommodate over each entrance in characters not less than 100 millimetres in height, of a colour contrasting with that of the liferaft canopy.
- 4.2 Provision shall be made for marking each liferaft with the name and port of registry of the ship to which it is to be fitted, in such a form that the ship identification can be changed at any time without opening the container.

#### *Instructions and Information*

- 5.1 Instructions and information shall be in a form suitable for the training manual and the instructions for on-board maintenance referred to in Schedule 14. Instructions and information shall be in English in a clear and concise form and shall include, as appropriate –
- 5.1.1 a general description of the liferaft and its equipment;
  - 5.1.2 the installation arrangements;
  - 5.1.3 operational instructions including use of associated survival equipment;
  - 5.1.4 survival instructions;
  - 5.1.5 emergency repair instructions;
  - 5.1.6 deployment, boarding and launching instructions;
  - 5.1.7 the method of release from within davit launched raft;
  - 5.1.8 the release from launching appliance;
  - 5.1.9 on-board maintenance requirements; and
  - 5.1.10 servicing requirements.

## PART 2 – INFLATABLE LIFERAFTS

### *General*

1. Every inflatable liferaft shall comply with the requirements of Part 1 and in addition shall comply with the requirements of this Part.

### *Construction*

- 2.1 The main buoyancy chamber shall be divided into –
  - 2.1.1 not less than two separate compartments, each inflated through a non-return inflation valve on each compartment;
  - 2.1.2 the buoyancy chambers shall be so arranged that in the event of one of the compartments being damaged or failing to inflate, the intact compartment shall be able to support, with positive freeboard over the liferaft's entire periphery, the number of persons which the liferaft is permitted to accommodate, each having a mass of 75 kilogrammes, and seated in their normal positions.
- 2.2 The floor of the liferaft shall be waterproof and shall be capable of being sufficiently insulated against cold either –
  - 2.2.1 by means of one or more compartments which the occupants can inflate, or which inflate automatically and can be deflated and reinflated by the occupants; or
  - 2.2.2 by other equally efficient means not dependent on inflation.
- 2.3 The liferaft shall be capable of being inflated by one person. The liferaft shall be inflated with a non-toxic gas by an inflation system. Inflation shall be completed within 1 minute at an ambient temperature of between 18°C and 20°C and within 3 minutes at an ambient temperature of –30°C. After inflation the liferaft shall maintain its form when loaded with its full complement of persons and equipment.
- 2.4 Each inflatable compartment shall be capable of withstanding a pressure at least 3 times the working pressure and shall be prevented from reaching a pressure exceeding twice the working pressure either by means of relief valves or by a limited gas supply. Means shall be provided for connecting the topping-up pump or bellows required by Part 6 so that the working pressure can be maintained.
- 2.5 The number of persons which a liferaft shall be permitted to accommodate shall be equal to the lesser of –
  - 2.5.1 the greatest whole number obtained by dividing by 0.096 the volume, measured in cubic metres, of the main buoyancy tubes (which for this purpose shall include neither the arches nor the thwarts if fitted) when inflated;
  - 2.5.2 the greatest whole number obtained by dividing by 0.372 the inner horizontal cross sectional area of the liferaft, measured in square metres, (which for this purpose may include the thwart or thwarts, if fitted) measured to the innermost edge of the buoyancy tubes; or
  - 2.5.3 the number of persons having an average mass of 75 kilogrammes, all wearing either immersion suits and lifejackets or, in the case of davit-launched liferafts, that can be seated with sufficient comfort and headroom without interfering with the operation of any of the liferaft's equipment.

## *Fittings*

- 3.1 At least one entrance shall be fitted with a semi-rigid boarding ramp capable of supporting a person weighing 100 kilogrammes to enable persons to board the liferaft from the sea. The boarding ramp shall be so arranged as to prevent significant deflation of the liferaft if the ramp is damaged. Liferafts accommodating more than 25 persons shall have at least two diametrically opposite entrances fitted with semi-rigid boarding ramps. In the case of davit-launched liferafts a boarding ramp shall not be fitted at the entrance where bowsing lines and embarkation facilities are fitted
- 3.2 The stability of liferafts capable of accommodating 25 persons or less when in the inverted position shall be such that they can be righted in a sea-way and in calm water by one person. Liferafts in excess of 25 persons capacity shall have righting facilities. The righting position of the liferaft shall be suitably marked and have a non-skid surface.
- 3.3 The liferaft shall be fitted with water pockets complying with the following requirements –
- 3.3.1 the cross-sectional area of the pockets shall be in the shape of an isosceles triangle with the base of the triangle attached to the underside of the liferaft;
  - 3.3.2 the design shall be such that the pockets fill to approximately 60 per cent of capacity within 15 to 25 seconds of deployment;
  - 3.3.3 the pockets shall have an aggregate capacity of at least 220 litres for inflatable liferafts up to and including the 10 person size;
  - 3.3.4 the pockets to be fitted on liferafts certified to carry more than 10 persons shall have an aggregate capacity of  $(20 \times N)$  litres, where N = number of persons the liferaft is certified to carry;
  - 3.3.5 the pockets shall be attached on all of their sides to the underside of the liferaft;
  - 3.3.6 the pockets shall be distributed symmetrically round the circumference of the liferaft either side of the carbon dioxide bottle with sufficient separation between each pocket to enable air to escape readily; and
  - 3.3.7 the pockets shall be of a highly visible colour.

## *Davit-launched inflatable liferafts*

- 4.1 In addition to the above requirements, a liferaft for use with an approved launching appliance complying with Part 3 of Schedule 6 shall –
- 4.1.1 when the liferaft is loaded with its full complement of persons and equipment, be capable of withstanding a lateral impact against the ship's side at an impact velocity of not less than 3.5 metres per second and also a drop into the water from a height of not less than 3 metres without damage that will affect its function;
  - 4.1.2 be provided with means for bringing the liferaft alongside the embarkation deck and holding it securely during embarkation. The distance between the liferaft and the bowsing line securing point shall be kept to a minimum to restrict movement of the liferaft during boarding; and
  - 4.1.3 when suspended from its lifting hook or bridle, withstand a load of –
    - 4.1.3.1 4 times the mass of its full complement of persons and equipment, at an ambient temperature and a stabilised liferaft temperature of  $20 \pm 3^{\circ}\text{C}$  with all relief valves inoperative; and

**4.1.3.2** 1.1 times the mass of its full complement of persons and equipment at an ambient temperature and a stabilised liferaft temperature of  $-30^{\circ}\text{C}$  with all relief valves operative.

- 4.2** Rigid containers for liferafts to be launched by a launching appliance shall be so secured that the container or parts of it are prevented from falling into the sea during inflation and launching of the liferaft.
- 4.3** Every passenger ship davit-launched liferaft shall be so arranged that it can be rapidly boarded by its full complement of persons.
- 4.4** Every cargo ship davit-launched, inflated liferaft shall be so arranged that it can be boarded by its full complement of persons in not more than 3 minutes from the time the instruction to board is given.

#### *Automatic self-righting inflatable liferafts*

- 5.1** Automatic self-righting inflatable liferafts shall comply with the requirements of Part 1 and of this Part except for the requirements of paragraphs 3.2, 4.1, 6.1 and 7.2.
- 5.2** The liferaft with all of its equipment and no persons on board shall automatically turn from a capsized position to an upright position on the surface of the water, regardless of whether it inflates in the inverted position underwater or on the surface of the water or capsizes for any reason following inflation.

#### *Canopied reversible inflatable liferafts*

- 6.1** Canopied reversible inflatable liferafts shall comply with the requirements of Part 1 and of this Part except for the requirements of paragraphs 3.2, 3.3, 4.1, 5.1 and 7.2.
- 6.2** The liferaft shall:
  - 6.2.1** be capable of being safely used at all times by untrained persons;
  - 6.2.2** be capable of operating safely whichever way up it is floating. The liferaft shall have a canopy on both sides of the main body, if applicable, of the liferaft, which shall be set in place when the liferaft is launched and waterborne. Both canopies shall meet the requirements of Part 1 paragraphs 2.5, 3.8 and 3.9.
  - 6.2.3** ensure that the equipment required under Part 6 shall be readily accessible whichever way up the canopied reversible liferaft is floating, either by use of an equipment container which is accessible from either side, or by duplication of equipment on each side of the liferaft; and
  - 6.2.4** ensure that the fully equipped canopied reversible liferaft with one person of 75 kilogrammes on board, shall float in a stable upright position in a seaway.

#### *Containers for inflatable liferafts*

- 7.1** The liferaft shall be packed in a container that is –
  - 7.1.1** so constructed as to withstand conditions encountered at sea;
  - 7.1.2** of sufficient inherent buoyancy, when packed with the liferaft and its equipment, to pull the painter from within and to operate the inflation mechanism should the ship sink; and
  - 7.1.3** as far as practicable watertight, except for drain holes in the container bottom.

- 7.2 The liferaft shall be packed in its container in such a way as to ensure, as far as possible, that the waterborne liferaft inflates in an upright position on breaking free from its container.
- 7.3 The container shall be marked with the –
- 7.3.1 maker's name or trade mark;
  - 7.3.2 serial number;
  - 7.3.3 number of persons it is permitted to carry;
  - 7.3.4 words "SOLAS 98";
  - 7.3.5 type of emergency pack enclosed;
  - 7.3.6 date when last serviced;
  - 7.3.7 length of painter;
  - 7.3.8 maximum permitted height of stowage above waterline (depending on drop-test height and length of painter); and
  - 7.3.9 launching instructions.

**Other Ships Regulations**  
regs 46, 48, 63, 64, 65, 66, 67, 68 and 69

### **PART 3 – RIGID LIFERAFTS**

#### *General*

1. Every rigid liferaft shall comply with the requirements of Part 1 and in addition with the requirements of this Part.

#### *Construction*

- 2.1 The buoyancy of the liferaft shall be provided by approved inherently buoyant material placed as near as possible to the periphery of the liferaft. The buoyant material shall be fire retardant or be protected by a fire-retardant covering.
- 2.2 The number of persons which a liferaft shall be permitted to accommodate shall be equal to the lesser of –
- 2.2.1 the greatest whole number obtained by dividing by 0.096 the volume, measured in cubic metres, of the buoyancy material multiplied by a factor of 1 minus the specific gravity of that material;
  - 2.2.2 the greatest whole number obtained by dividing by 0.372 the horizontal cross-sectional area of the floor of the liferaft, measured in square metres; or
  - 2.2.3 the number of persons having an average mass of 75 kilogrammes, all wearing immersion suits and lifejackets, that can be seated with sufficient comfort and headroom without interfering with the operation of any of the liferaft's equipment.
- 2.3 The floor of the liferaft shall prevent the ingress of water and shall effectively support the occupants out of the water and insulate them from the cold.

### *Fittings*

- 3.1 At least one entrance shall be fitted with a rigid boarding ramp to enable persons to board the liferaft from the sea. In the case of a davit-launched liferaft having more than one entrance, the boarding ramp shall not be fitted at the entrance where bowsing lines and embarkation facilities are fitted.
- 3.2 Unless the liferaft is capable of operating safely whichever way up it is floating, its strength and stability shall be such that it is either self-righting or can be readily righted in a sea-way and in calm water by one person.
- 3.3 The stability of a liferaft when loaded with its full complement of persons and equipment shall be such that it can be towed at speeds of up to 3 knots in calm water.

### *Markings*

- 4.1 In addition to the markings required by section 4 of Part 1, rigid liferafts shall be marked with the –
  - 4.1.1 name and port of registry of the ship to which it belongs;
  - 4.1.2 words "SOLAS 98";
  - 4.1.3 type of emergency pack enclosed;
  - 4.1.4 length of painter;
  - 4.1.5 date of manufacture (month and year);
  - 4.1.6 maximum permitted height of stowage above waterline (depending on drop-test height and length of painter); and
  - 4.1.7 launching instructions.

### *Davit-launched rigid liferafts*

- 5.1 A rigid liferaft for use with an approved launching appliance complying with Part 3 of Schedule 6 shall –
  - 5.1.1 when suspended from its lifting hook or bridle, withstand a load of 4 times the mass of its full complement of persons and equipment;
  - 5.1.2 when the liferaft is loaded with its full complement of persons and equipment, be capable of withstanding a lateral impact against the ship's side at an impact velocity of not less than 3.5 metres per second and also a drop into the water from a height of not less than 3 metres without damage that will affect its function; and
  - 5.1.3 be provided with means for bringing the liferaft alongside the embarkation deck and holding it securely during embarkation. The distance between the liferaft and the bowsing line securing point shall be kept to a minimum to restrict movement of the liferaft during boarding.
- 5.2 Every passenger ship davit-launched liferaft shall be so arranged that it can be rapidly boarded by its full complement of persons.
- 5.3 Every cargo ship davit-launched liferaft shall be so arranged that it can be boarded by its full complement of persons in not more than 3 minutes from the time the instruction to board is given.

### *Automatic self-righting rigid liferafts*

- 6.1 Automatic self-righting rigid liferafts shall comply with the requirements of Part 1 and of this Part, except for the requirements of paragraphs 3.2, 5.1 and 7.1
- 6.2 The liferaft with all of its equipment and no persons on board shall automatically turn from a capsized position to an upright position on the surface of the water, regardless of whether it lands in the inverted position or capsizes for any reason following inflation.

### *Canopied reversible rigid liferafts*

- 7.1 Canopied reversible rigid liferafts shall comply with the requirements of Part 1 and of this Part except for the requirements of paragraphs 3.2, 5.1 and 6.1.
- 7.2 The liferaft shall:
  - 7.2.1 be capable of being safely used at all times by untrained persons.
  - 7.2.2 be capable of operating safely whichever way up it is floating. The liferaft shall have a canopy on both sides of the main body, if applicable, of the liferaft, which shall be set in place when the liferaft is launched and waterborne. Both canopies shall meet the requirements of Part 1 paragraphs 2.5, 3.8 and 3.9.
  - 7.2.3 ensure that the equipment required under Part 6 shall be readily accessible whichever way up the canopied reversible liferaft is floating, either by use of an equipment container which is accessible from either side, or by duplication of equipment on each side of the liferaft; and
  - 7.2.4 ensure that the fully equipped canopied reversible liferaft with one person of 75 kilogrammes on board, shall float in a stable upright position in a seaway.

**Small Passenger Ship Regulations**  
regs 5, 6, 7, 8 and 9

## **PART 4 – OPEN REVERSIBLE LIFERAFTS**

### *General*

- 1.1 Liferafts shall –
  - 1.1.1 be constructed with proper workmanship and materials;
  - 1.1.2 not be damaged in stowage in the air temperature range of  $-18^{\circ}\text{C}$  to  $+65^{\circ}\text{C}$ ;
  - 1.1.3 be capable of operating in the air temperature range of  $-18^{\circ}\text{C}$  to  $+65^{\circ}\text{C}$ , and a sea water temperature range of  $-1^{\circ}\text{C}$  to  $+30^{\circ}\text{C}$ ;
  - 1.1.4 be rot-proof, corrosion-resistant, and not be unduly affected by sea-water, oil or fungal attack; and
  - 1.1.5 be stable and maintain their shape when inflated and fully laden.

### *Construction*

- 2.1 The liferaft shall be so constructed that when it is dropped into the water in its container from a height of 10 metres, the liferaft and its equipment will operate satisfactorily. If the



liferaft is to be stowed at a height of more than 10 metres above the waterline in the lightest seagoing condition, it shall be of a type which has been satisfactorily drop-tested from at least that height.

- 2.2** The floating liferaft shall be capable of withstanding repeated jumps on to it from a height of at least 4.5 metres.
- 2.3** The liferaft and its fittings shall be so constructed as to enable it to be towed at a speed of 3 knots in calm water when loaded with its full complement of persons and equipment, with the sea anchor deployed.
- 2.4** The liferaft when fully inflated shall be capable of being boarded from the water whichever way up it inflates.
- 2.5** The main buoyancy chamber shall be divided into –
- 2.5.1** not less than two separate compartments, each inflated through a non-return inflation valve on each compartment; and
- 2.5.2** the buoyancy chambers shall be so arranged that in the event of one of the compartments being damaged or failing to inflate, the intact compartment shall be able to support, with positive freeboard over the liferaft's entire periphery, the number of persons which the liferaft is permitted to accommodate, each having a mass of 75 kilogrammes, and seated in their normal positions.
- 2.6** The floor of the liferaft shall be waterproof.
- 2.7** The liferaft shall be inflated with a non-toxic gas by an inflation system. Inflation shall be completed within 1 minute at an ambient temperature of between 18°C and 20°C and within 3 minutes at an ambient temperature of –18°C. After inflation the liferaft shall maintain its form when loaded with its full complement of persons and equipment.
- 2.8** Each inflatable compartment shall be capable of withstanding a pressure equal to at least 3 times the working pressure and shall be prevented from reaching a pressure exceeding twice the working pressure either by means of relief valves or by a limited gas supply. Means shall be provided for fitting the topping-up pump or bellows.
- 2.9** At least 25 per cent of the buoyancy tubes are to be of a highly visible colour. In this respect it will be acceptable if the water pockets required by paragraph 3.5 are manufactured in a highly visible colour.
- 2.10** The number of persons which a liferaft shall be permitted to accommodate shall be equal to the lesser of –
- 2.10.1** the greatest whole number obtained by dividing by 0.075 the volume, measured in cubic metres, of the main buoyancy tubes (which for this purpose shall not include the thwarts if fitted) when inflated;
- 2.10.2** the greatest whole number obtained by dividing by 0.304 the inner horizontal cross sectional area of the liferaft, measured in square metres (which for this purpose may include the thwart or thwarts, if fitted) to the innermost edge of the buoyancy tubes; or
- 2.10.3** the number of persons having an average mass of 75 kilogrammes, all wearing lifejackets, that can be seated inboard of the buoyancy tubes without interfering with the operation of any of the liferaft's equipment.

- 2.11 No liferaft shall be approved with a carrying capacity of less than 4 or greater than 65 persons, calculated or determined in accordance with the requirements of paragraph 2.10.

### *Fittings*

- 3.1 Lifelines shall be securely becketed around the inside and outside of the liferaft.
- 3.2 The liferaft shall be fitted with an efficient painter of a length suitable for automatic inflation on reaching the water. For liferafts accommodating more than 30 persons an additional bowsing-in line is to be fitted.
- 3.3 The breaking strength of the painter system including its means of attachment to the liferaft except the weak link required by Part 8 shall be –
- 3.3.1 7.5 kilonewtons for liferafts accommodating up to 8 persons;
- 3.3.2 10.0 kilonewtons for liferafts accommodating 9 to 30 persons; and
- 3.3.3 15.0 kilonewtons for liferafts accommodating more than 30 persons.
- 3.4 The liferaft shall be fitted with at least the following number of inflated ramps to assist boarding from the sea whichever way up the raft inflates –
- 3.4.1 one boarding ramp for liferafts accommodating up to 30 persons; or
- 3.4.2 two boarding ramps for liferafts accommodating more than 30 persons.
- 3.5 The liferaft shall be fitted with water pockets complying with the following requirements –
- 3.5.1 the cross-sectional area of the pockets shall be in the shape of an isosceles triangle with the base of the triangle attached to the buoyancy tubes of the liferaft;
- 3.5.2 the design shall be such that the pockets fill to approximately 60 per cent of capacity within 15 to 25 seconds of deployment;
- 3.5.3 the pockets shall normally have aggregate capacity of between 125 litres and 150 litres for inflatable liferafts up to and including the 10 person size;
- 3.5.4 the pockets to be fitted to each buoyancy tube and on liferafts certified to carry more than 10 persons shall have as far as practicable an aggregate capacity of  $(12 \times N)$  litres, where N = number of persons the liferaft is certified to carry;
- 3.5.5 each pocket on a buoyancy tube should be attached so that when this pocket is in the deployed position it is attached along the full length of its upper edges to, or close to, the lowest point of the lowest buoyancy tube; and
- 3.5.6 the pockets shall be distributed symmetrically round the circumference of the liferaft with sufficient separation between each pocket to enable air to escape readily.
- 3.6 At least one manually controlled lamp complying with the requirements of Part 9 shall be fitted on the upper and lower surfaces of the buoyancy tubes.
- 3.7 Suitable automatic drainage arrangements are to be provided on each side of the floor of the liferaft in the following manner –
- 3.7.1 one for liferafts accommodating up to 30 persons; or
- 3.7.2 two for liferafts accommodating more than 30 persons.

- 3.8 The equipment of every liferaft shall consist of –
- 3.8.1 one buoyant rescue quoit, attached to not less than 30 metres of buoyant line with a breaking strain of at least 1.0 kiloNewtons;
  - 3.8.2 two safety knives of the non-folding type having buoyant handles are to be attached to the liferaft by light lines. They shall be stowed in pockets so that, irrespective of the way in which the liferaft inflates, they will be readily available on the top surface or the upper buoyancy tube in a suitable position to enable the painter to be readily cut;
  - 3.8.3 one buoyant bailer;
  - 3.8.4 two sponges;
  - 3.8.5 one sea-anchor permanently attached to the liferaft in such a way as to be readily deployable when the liferaft inflates. The position of the sea anchor should be clearly marked on both buoyancy tubes;
  - 3.8.6 two buoyant paddles;
  - 3.8.7 one first-aid outfit complying with the requirements of Schedule 13;
  - 3.8.8 one whistle or equivalent sound signal;
  - 3.8.9 two hand flares;
  - 3.8.10 one waterproof electric torch suitable for Morse signalling together with a spare set of batteries and a spare bulb in a waterproof container;
  - 3.8.11 one repair outfit for repairing punctures in buoyancy compartments; and
  - 3.8.12 one topping-up pump or bellows.
- 3.9 Liferafts equipped in accordance with paragraph 3.8 be marked in block capitals “E PACK”.
- 3.10 Where appropriate the equipment shall be stowed in a container which, if it is not an integral part of, or permanently attached to the liferaft, shall be stowed and secured to the liferaft and be capable of floating in water for at least 30 minutes without damage to its contents. Irrespective of whether the equipment container is an integral part of, or is permanently attached to, this open reversible liferaft, the equipment shall be readily accessible irrespective of which way up the open reversible liferaft inflates. The line which secures the equipment container to the liferaft shall have a breaking strain of 2 kiloNewtons or a breaking strain of 3:1 based on the mass of the complete equipment pack, whichever is the greater.

*Containers for open reversible inflatable liferafts*

- 4.1 The liferaft shall be packed in a container that is –
- 4.1.1 so constructed as to withstand conditions encountered at sea;
  - 4.1.2 of sufficient inherent buoyancy, when packed with the liferaft and its equipment, to pull the painter from within and to operate the inflation mechanism should the ship sink; and
  - 4.1.3 as far as practicable watertight, except for drain holes in the container bottom.

- 4.2 The container shall be marked with the –
- 4.2.1 maker's name or trade mark;
  - 4.2.2 serial number;
  - 4.2.3 number of persons it is permitted to carry;
  - 4.2.4 words "NON-SOLAS REVERSIBLE";
  - 4.2.5 type of emergency pack enclosed;
  - 4.2.6 date when last serviced;
  - 4.2.7 length of painter;
  - 4.2.8 maximum permitted height of stowage above waterline (depending on drop-test height); and
  - 4.2.9 launching instructions.

### *Markings*

- 5.1 The liferaft shall be marked with the –
- 5.1.1 maker's name or trade mark;
  - 5.1.2 serial number;
  - 5.1.3 date of manufacture (month and year);
  - 5.1.4 name and place of service station where it was last serviced; and
  - 5.1.5 number of persons it is permitted to accommodate on the top of each buoyancy tube in characters not less than 100 millimetres in height and of a colour contrasting with that of the tube.

### *Instructions and Information*

- 6.1 Instructions and information shall be in a form suitable for the training manual and the instructions for on-board maintenance referred to in Schedule 14. Instructions and information shall be in English in a clear and concise form and shall include, as appropriate –
- 6.1.1 a general description of the liferaft and its equipment;
  - 6.1.2 the installation arrangements;
  - 6.1.3 operational instructions including use of associated survival equipment;
  - 6.1.4 launching, deployment and boarding instructions; and
  - 6.1.5 servicing requirements.

## PART 5 – INFLATABLE LIFE RAFTS (NON-SOLAS)

### General

1. Liferafts carried on board ships of Classes IX(A), IX(A)(T) and in ships of Class XII of less than 21.3 metres in length shall comply with the requirements of Part 1 and 2 provided that paragraphs 1.2 of Schedule 1, 2.2, 2.5.6, 2.6 and 3.3 of Part 1 and 2.3, 4.1.3.2 and 5.4.4 of Part 2 may be modified as follows –
  - 1.1 the drop height of 18 metres referred to in paragraph 2.2 of Part 1 may be 6 metres; if the liferaft is to be stowed at a height of more than 6 metres above the waterline in the lightest seagoing condition, it shall be of a type which has been satisfactorily drop-tested from at least that height;
  - 1.2 the means for collecting rain referred to in paragraph 2.5.6 of Part 1 need not be provided;
  - 1.3 the means for insulating the floor of the liferaft against cold as referred to in paragraph 2.6 of Part 2 need not be provided;
  - 1.4 the temperature of  $-30^{\circ}\text{C}$  referred to in paragraph 1.2 of Schedule 1, paragraph 2.3 and paragraph 4.1.3.2 of Part 2 may be  $-18^{\circ}\text{C}$ ;
  - 1.5 the minimum carrying capacity of liferafts required by paragraph 2.6 of Part 1 as 6 persons may be four provided that liferafts which are deemed fit to accommodate less than 6 persons shall only be carried on such ships on which the total number of persons on board is less than six;
  - 1.6 in determining a minimum length of a painter 10 metres shall be substituted for the 15 metres referred to in paragraph 3.3 of Part 1; and
  - 1.7 the container shall be marked with “DOT(UK) 98” in lieu of the marking required by paragraph 5.4.4 of Part 2.

Schedule 4 Part 1 and 2

## PART 6 – LIFERAFT EQUIPMENT (SOLAS)

- 1.1 Subject to the provisions of paragraph 1.3, 1.5, 1.7 and 1.9 the equipment of every liferaft shall consist of –
  - 1.1.1 one buoyant rescue quoit, attached to not less than 30 metres of buoyant line with a breaking strain of at least 1.0 kiloNewton;
  - 1.1.2 one safety knife of the non-folding type having a buoyant handle and stowed in a pocket on the upper buoyancy tube near the entrance adjacent to the painter and secured to the liferaft by a light line of sufficient length to enable the painter to be readily cut. In addition, a liferaft which is permitted to accommodate 13 persons or more shall be provided with a second safety knife which need not be of the non-folding type. The stowage position of the knives shall be highlighted;
  - 1.1.3 for a liferaft which is permitted to accommodate not more than 12 persons, one buoyant bailer; for a liferaft which is permitted to accommodate 13 persons or more, two buoyant bailers;

- 1.1.4 two sponges;
  - 1.1.5 two sea-anchors, one being spare and the other permanently attached to the liferaft in such a way as to be readily deployable when the liferaft inflates to enable the liferaft to lie oriented to the wind in the most stable manner;
  - 1.1.6 two buoyant paddles;
  - 1.1.7 three tin openers; and a pair of scissors. Safety knives containing special tin opener blades are satisfactory for this equipment. Scissors shall be of the safety type;
  - 1.1.8 one first-aid outfit complying with the requirements of Schedule 13;
  - 1.1.9 one whistle or equivalent sound signal;
  - 1.1.10 four rocket parachute flares;
  - 1.1.11 six hand flares;
  - 1.1.12 two buoyant smoke signals;
  - 1.1.13 one waterproof electric torch suitable for Morse signalling together with a spare set of batteries and a spare bulb in a waterproof container;
  - 1.1.14 an efficient radar reflector unless a radar transponder is stowed in the liferaft;
  - 1.1.15 one daylight signalling mirror with instructions on its use for signalling to ships and aircraft;
  - 1.1.16 one copy of the Department of Transport's Rescue Signal Table published by Her Majesty's Stationery Office;
  - 1.1.17 One set of fishing tackle;
  - 1.1.18 food ration complying with the requirements of Schedule 13 and totalling not less than 10,000 kilojoules for each person the liferaft is permitted to accommodate; these rations shall be stowed in a watertight container;
  - 1.1.19 watertight receptacles containing a total of 1.5 litres of fresh water complying with the requirements of Schedule 13 for each person the liferaft is permitted to accommodate, of which 0.5 litres per person may be replaced by a de-salting apparatus capable of producing an equal amount of fresh water in 2 days or 1 litre per person may be replaced by a manually powered reverse osmosis desalinator capable of producing an equal amount of fresh water in 2 days;
  - 1.1.20 one rust-proof drinking vessel graduated in millilitres;
  - 1.1.21 six doses of anti-seasickness medicine and one seasickness bag for each person the liferaft is permitted to accommodate;
  - 1.1.22 instructions printed in English on how to survive;
  - 1.1.23 instructions for immediate action; and
  - 1.1.24 thermal protective aids sufficient for 10 per cent of the number of persons the liferaft is permitted to accommodate, or two, whichever is the greater.
- 1.2 Liferafts equipped in accordance with paragraph 1.1 shall be marked in block capitals "SOLAS A PACK".

- 1.3 Liferafts carried on passenger ships engaged on short international voyages shall be provided with the equipment specified in paragraphs 1.1.1 to 1.1.6 inclusive, 1.1.8, 1.1.9, 1.1.13 to 1.1.16 inclusive and 1.1.21 to 1.1.24 inclusive and one half of the equipment specified in paragraphs 1.1.10 to 1.1.12 inclusive.
- 1.4 Liferafts equipped in accordance with paragraph 1.3 shall be marked in block capitals "SOLAS B PACK".
- 1.5 Liferafts carried on board ships of Classes IX(A) and IX(A)(T) shall be provided with the equipment specified in paragraphs 1.1.1 to 1.1.4 inclusive, 1.1.9, 1.1.13, 1.1.16, 1.1.22 and 1.1.23 and one half of the equipment specified in paragraph 1.1.5.
- 1.6 Liferafts equipped in accordance with paragraph 1.5 shall be marked in block capitals "C PACK".
- 1.7 Liferafts carried on board ships of Class XII of less than 21.3 metres in length shall be provided with the equipment specified in paragraphs 1.1.1 to 1.1.6 inclusive, 1.1.8, 1.1.9, 1.1.13, 1.1.15, 1.1.16, 1.1.17, 1.1.20 to 1.1.24 inclusive and one half of the equipment specified in paragraphs 1.1.10 to 1.1.12 inclusive together with the following equipment –
- 1.7.1 one safety tin opener;
- 1.7.2 one third of the food ration required by paragraph 1.1.18; and
- 1.7.3 watertight receptacles containing a total of 0.5 litres of fresh water for each person the liferaft is permitted to accommodate.
- 1.8 Liferafts equipped in accordance with paragraph 1.7 shall be marked in block capitals "D PACK".
- 1.9 Liferafts carried on board ships of Classes III, IV, V, VI and VI(A) may be provided with equipment specified in paragraphs 1.1.1, 1.1.4, 1.1.6, 1.1.8, 1.1.9 and 1.1.13 and two of the safety knives specified in 1.1.2, two buoyant bailers specified in 1.1.3 one sea anchor specified in 1.1.5 and two hand flares specified in 1.1.11.
- 1.10 Where appropriate the equipment shall be stowed in a container which, if it is not an integral part of, or permanently attached to, the liferaft, shall be stowed and secured inside the liferaft and be capable of floating in water for at least 30 minutes without damage to its contents. The line which secures the equipment container to the liferaft shall have a breaking strain of 2 kiloNewtons or a breaking strain of 3:1 based on the mass of the complete equipment pack, whichever is the greater.
- 1.11 In addition to the above requirements every inflatable liferaft shall be provided with –
- 1.11.1 one repair outfit for repairing punctures in buoyancy compartments; and
- 1.11.2 one topping-up pump or bellows.

Schedule 6 Part 1

## PART 7 – AUTOMATIC RELEASE HOOKS

### *Definitions*

1. In this Part the following definitions apply –

- 1.1 "actuating force" means the force required to set the actuating mechanism;

- 1.2 "actuating mechanism" means the mechanism which, when operated, allows the liferaft to be released automatically;
- 1.3 "automatic release mechanism" means the mechanism which opens the hook automatically to release the liferaft; and
- 1.4 "hook" means a hook to be used for the launching of liferafts which can be activated to automatically release the liferaft when it is waterborne.

#### *Functional criteria*

- 2.1 The hook shall be reliable and easily handled by one person during the preparation embarkation, launching and release of the liferaft.
- 2.2 The hook and its accessories shall be made of materials suitable for use in the marine environment.
- 2.3 A minimum factor of safety of 6 based on the ultimate strength of the materials used shall be applied to the design of all parts of the hook.
- 2.4 The lever for manual release and the actuating mechanism may be separate.
- 2.5 There shall be a clear and durable indicator to show if the actuating mechanism has been operated. The automatic release mechanism shall be such that positions between "safe" and "cocked" are not possible.
- 2.6 When the hook is in the automatic release position the liferaft shall be released as soon as it is waterborne. The release shall be immediate and complete. Means shall be provided to ensure that the hook does not open when the liferaft swings, bumps into the ship's side or is otherwise influenced by the wind during the lowering operation.
- 2.7 The hook shall be capable of release manually after launching. The manual release mechanism shall be designed having regard to the risk of unintentional release during the preparation, embarkation and lowering of the liferaft.
- 2.8 The release hook shall include a capability to release the hook under load. The on-load release control shall –
  - 2.8.1 be clearly differentiated from the control which activates the automatic release function;
  - 2.8.2 require at least two separate actions to operate;
  - 2.8.3 with a load of 150 kilogrammes on the hook, require a force of at least 600 and not more than 700 Newtons to release the load, or provide equivalent adequate protection against inadvertent release of the hook; and
  - 2.8.4 be designed such that the crew members on deck can clearly observe when the release mechanism is properly and completely set.

#### *Compatibility*

3. The operation of automatic release hooks shall be compatible with the type, size and manufacture of the inflatable liferafts carried, and this shall be established by operational tests before a particular combination of release hook and liferaft is acceptable.



## *Instructions and Information*

4. Instructions and information shall be in a form suitable for the training manual and the instructions for on-board maintenance referred to in Schedule 14. Instructions and information shall be in English in a clear and concise form and shall include a description of the operation and maintenance of the automatic release hook.

Small Passenger Ship Regulations  
reg 2

Other Ships Regulation  
regs 7, 8, 9, 51 and 72

## **PART 8 – FLOAT FREE ARRANGEMENTS**

### *General*

1. Float free arrangements shall provide for a liferaft to be released automatically in the event of a ship sinking.

### *Painter System*

2. The liferaft painter system shall provide a connection between the ship and the liferaft and shall be so arranged as to ensure that the liferaft when released, and in the case of an inflatable liferaft when inflated, is not dragged under by the sinking ship.

### *Hydrostatic Release Unit*

#### *Construction*

- 3.1 A hydrostatic release unit used in the float-free arrangements shall be so constructed that –
  - 3.1.1 the materials used are compatible and do not cause the unit to malfunction. No part of the release unit shall be galvanised or treated by other forms of metallic coating;
  - 3.1.2 there is adequate drainage to prevent the accumulation of water in the hydrostatic chamber when the unit is in its normal position;
  - 3.1.3 each part connected to the painter system has a strength not less than that required by the painter; and
  - 3.1.4 it can readily be removed for replacement or annual servicing.

#### *Materials and Components*

- 3.2 Materials and components shall be corrosion-resistant and not affected by seawater, oil or detergents.

#### *Performance*

- 3.3 A hydrostatic release unit shall –
  - 3.3.1 function properly in the air temperature range of  $-30^{\circ}\text{C}$  to  $+65^{\circ}\text{C}$ ;
  - 3.3.2 function properly in a seawater temperature range of  $-1^{\circ}\text{C}$  to  $+30^{\circ}\text{C}$ ;
  - 3.3.3 automatically release the liferaft at a depth of not more than 4 metres;
  - 3.3.4 not release prematurely when seas wash over the unit; and
  - 3.3.5 be capable of releasing a liferaft when the stowage is –

- 3.3.5.1 horizontal;
- 3.3.5.2 tilted 45 degrees and 100 degrees with the hydrostatic release unit at the upper side;
- 3.3.5.3 tilted 45 degrees and 100 degrees with the hydrostatic release unit at the lower side; or
- 3.3.5.4 vertical.

### *Marking*

- 3.4 A hydrostatic release unit shall be marked permanently on its exterior to identify its type and serial number and depth at which it will release the liferaft. In addition, if it is of a type which –
  - 3.4.1 requires servicing, it shall be marked with its date of manufacture and provided with a plate permanently attached to the unit for recording the date of servicing; and
  - 3.4.2 is disposable, with the date at which it must be replaced.

### *Instructions and Information*

- 3.5 Instructions and information must be in a form suitable for the training manual and the instructions for on-board maintenance referred to in Schedule 14. Instructions and information shall be in English in a clear and concise form and shall include –
  - 3.5.1 a general description of the unit;
  - 3.5.2 installation instructions;
  - 3.5.3 any on-board maintenance requirements; and
  - 3.5.4 servicing requirements.

### *Weak Link*

#### *Construction and Materials*

- 4.1 The weak link used in the float-free arrangements shall –
  - 4.1.1 be made from material which is corrosion resistant and not affected by seawater, oil or detergent;
  - 4.1.2 when made of cordage, have the ends either whipped or heat treated; and
  - 4.1.3 when made from flexible wire, have each end looped around a thimble and secured with a locking ferrule.

#### *Performance*

- 4.2 The weak link shall be of sufficient strength to –
  - 4.2.1 pull the painter out of the liferaft container;
  - 4.2.2 operate the liferaft inflation system; and
  - 4.2.3 break under a tensile force of between 1.8 and 2.6 kiloNewtons.

**PART 9 – LIFERAFT LIGHTS***General*

- 1.1 The lights shall be manually controlled but, in the case of an inflatable liferaft, operate automatically when the liferaft inflates and, in the case of a rigid liferaft, when the canopy is set in place.
- 1.2 Each light shall be connected independently to its own power source.
- 1.3 The external light may be of a flashing type.

*Construction*

- 2.1 The complete light unit shall be constructed with proper workmanship and materials.
- 2.2 It shall be capable of withstanding the drop-test on a liferaft without damage to the light or the liferaft.
- 2.3 It shall be capable of withstanding a drop of 2 metres on to a rigidly mounted steel plate or concrete surface.
- 2.4 It shall be rot-proof, corrosion-resistant, and not be unduly affected by seawater, oil or fungal growth.
- 2.5 It shall not deteriorate due to damp or humidity when stowed with a liferaft in its container.
- 2.6 The power source shall be a sea activated or dry chemical cell battery.
- 2.7 The power source shall be proofed against leakage of any chemicals which could damage or cause deterioration of any fabrics used in the construction of the liferaft.
- 2.8 The connection between light and power source shall be suitably protected.
- 2.9 The power source, in the inactive condition with the terminals covered, shall be capable of being immersed for 30 days in salt water without deterioration or loss of power.
- 2.10 The lamp holder and lens shall be so constructed as to prevent the ingress of water.
- 2.11 A flashing light shall not be fitted with a lens or curved reflector to concentrate the beam.

*Performance*

- 3.1 The lights shall have an operational endurance of not less than 12 hours.
- 3.2 They shall not be damaged in storage and shall operate in a satisfactory manner in the air temperature range  $-30^{\circ}\text{C}$  to  $+65^{\circ}\text{C}$ .
- 3.3 They shall operate in a satisfactory manner in a seawater temperature range of  $-1^{\circ}\text{C}$  to  $+30^{\circ}\text{C}$ .

- 3.4 They shall have a shelf life of not less than 3 years.
- 3.5 Internal lights shall be of sufficient luminous intensity to enable survival and equipment instructions to be read.
- 3.6 External lights shall be white with a luminous intensity of not less than 4.3 candela in all directions of the upper hemisphere.
- 3.7 It shall be visible through 360 degrees in a horizontal direction and, when attached to a liferaft, over as great a segment of the upper hemisphere as is practical.
- 3.8 In the case of a flashing light it shall flash at a rate of not less than 50 and not more than 70 flashes per minute for the 12 hour operating period with an equivalent effective luminous intensity required by paragraph 3.6.

*Markings*

- 4.1 The power source shall be marked externally with the –
  - 4.1.1 manufacturer's name or trade mark;
  - 4.1.2 type and batch number; and
  - 4.1.3 date of manufacture and expiry.
- 4.2 If the power source is a chemical pressurised cell it shall be clearly marked with a suitable warning notice.

## SCHEDULE 5

### MARINE ESCAPE SYSTEMS AND MEANS OF RESCUE SYSTEM

#### PART 1 – MARINE EVACUATION SYSTEM

##### *General*

- 1.1 A marine escape system shall provide a complete evacuation system for survivors, consisting of an inflatable escape chute, an inflatable floating boarding platform and a specified number of inflatable liferafts.
- 1.1.1 The passage of the marine evacuation system shall provide for safe descent of persons of various ages, sizes and physical capabilities wearing approved lifejackets from the embarkation station to the floating platform or survival craft.
- 1.2 The system shall comply with the requirements of Schedule 1 wherever applicable.
- 1.3 The system shall be –
- 1.3.1 sited clear of propellers and stabilisers;
  - 1.3.2 capable of removal for annual servicing;
  - 1.3.3 fitted with float free facilities complying with the requirements of Part 8 of Schedule 4 on those parts of the system intended for use as inflatable survival equipment;
  - 1.3.4 rapidly deployed by a single action using a gas inflation arrangement;
  - 1.3.5 provided with at least 50 per cent more gas than that required to inflate the system so that any loss of pressure sustained during a deployment can rapidly be replenished;
  - 1.3.6 provided, if the inflation system includes air aspiration, with the means of protecting the aspirator from damage and the ingress of water;
  - 1.3.7 capable of satisfactory operation in a sea-way; and
  - 1.3.8 capable of deployment by one person.

##### *Construction*

- 2.1 The container housing the escape chute and the boarding platform shall be –
- 2.1.1 strong enough to withstand the forces imposed upon it in severe weather conditions when the chute and platform is fully deployed and the maximum agreed number of fully loaded inflatable liferafts are attached to the platform. If the system is deployed using a support boom, then both the boom and the container shall be strong enough to safely withstand a load which is twice that imposed by the above conditions, without causing damage or distortion to either the boom or the container;
  - 2.1.2 suitably constructed on the outboard side to resist damage and to prevent ingress of water;

- 2.1.3 suitably protected on the inboard side to prevent damage or accidental deployment by unauthorised personnel;
  - 2.1.4 prominently labelled on the inboard side with clear deployment instructions;
  - 2.1.5 large enough to house the gas inflation system;
  - 2.1.6 provided with quick release of the outer door by a secure single-action arrangement;
  - 2.1.7 designed so that deployment of the system over the side will also activate the inflation arrangements;
  - 2.1.8 provided with a safe access to the top of the chute for those evacuating the ship;
  - 2.1.9 provided with a secure, manual release arrangement for the chute so that it can be jettisoned for additional buoyant support;
  - 2.1.10 fitted on board with portable securing arrangements so that it can be removed for annual servicing; and
  - 2.1.11 be provided with adequate drainage arrangements.
- 2.2 The escape chute which is part of the system shall –
- 2.2.1 consist of a single or double track slide with each track of sufficient width to prevent unrestricted evacuation by persons wearing an approved type of lifejacket;
  - 2.2.2 be of sufficient strength in its fully inflated condition to safely support a load of 300 kilogrammes (150 kilogrammes for a single track slide) at mid-length without bending or distorting;
  - 2.2.3 be sub-divided such that the loss of gas in any one compartment will not restrict its operational use as a means of evacuation;
  - 2.2.4 be provided with a slide path which will drain quickly and be safe to operate in wet conditions;
  - 2.2.5 be provided with vertically inflated panels on each side of the slide path of sufficient depth to permit safe evacuation in severe weather conditions; and
  - 2.2.6 be effectively connected to the chute container by arrangements which are capable of withstanding a load which is at least twice the load imposed in the maximum loaded condition.
- 2.3 The boarding platform, if fitted shall be –
- 2.3.1 stable in a seaway and provide a safe working area for those operating the system;
  - 2.3.2 self draining;
  - 2.3.3 sub-divided in such a way that the loss of gas from any one compartment will not restrict its operational use as a means of evacuation;
  - 2.3.4 of sufficient area that will provide for the securing of at least two liferafts for boarding and to accommodate at least the number of persons that at any time are expected to be on the platform. This usable platform area shall be at least equal to:

$$\frac{20\% \text{ of total number of persons that the marine evacuation system is certified for}}{4} \text{ m}^2$$

or 10 square metres whichever is the greater. Alternative arrangements may be approved subject to a demonstration that they comply with all the prescribed performance requirements;

- 2.3.5 such that sufficient buoyancy will be provided for the working load. In the case of an inflatable platform, the main buoyancy chambers, which for this purpose shall include any thwarts or floor inflatable structural members are to meet the requirements of Part 2, Schedule 4, based upon the platform capacity except that the capacity shall be obtained by dividing by 0.25 the usable area given in paragraph 2.3.4;
- 2.3.6 fitted with stabilising waterpockets designed in accordance with the standards stated in Part 2 of Schedule 4;
- 2.3.7 restrained by a bowsing line which is designed to deploy automatically as the system inflates so as to prevent it drifting to a position where it would be deployed at an angle of more than 45 degrees to the ship's side;
- 2.3.8 provided with mooring and bowsing line patches of sufficient strength to tie off the largest inflatable liferaft associated with the system; and
- 2.3.9 provided with a means of quick release from the chute and, if intended for use as an inflatable liferaft, comply with the appropriate requirements of Part 2 of Schedule 4.

*Performance of the System*

3. A marine escape system shall –

- 3.1 be capable of deployment by one person at the embarkation position;
- 3.2 not interfere with the deployment of any other life-saving equipment fitted in the ship;
- 3.3 be capable of transferring twice the number of persons it is designed to evacuate without significant deterioration of the slide paths;
- 3.4 be capable of satisfactory operation in a sea-way;
- 3.5 in the case of a passenger ship, be capable of transferring from the ship into the inflated liferafts the total number of persons for which the system is designed to evacuate within a period of 30 minutes and in the case of the cargo ship within 10 minutes from the time the abandon ship signal is given;
- 3.6 be capable of deployment from a passenger ship with a trim of up to 10 degrees and a list of up to 20 degrees either way;
- 3.7 In the case of being fitted with an inclined slide, such that the angle of the slide to the horizontal is –
  - 3.7.1 within a range of 30 degrees to 35 degrees when the ship is upright and in the lightest sea-going condition; and

- 3.7.2 in the case of a passenger ship, a maximum of 55 degrees in the final stage of flooding set by the requirements in Schedule 3, paragraph 2 of The Merchant Shipping Notice MSN 1698 (M).
- 3.8 evaluated for capacity by means of timed evacuation deployments conducted in harbour;
- 3.9 capable of providing a satisfactory means of evacuation in a sea state associated with a wind of force 6 on the Beaufort scale;
- 3.10 designed to, as far as practicable, remain effective under conditions of icing;
- 3.11 so constructed that only a minimum amount of routine maintenance is necessary. Any part requiring maintenance by the ship's crews shall be readily accessible and easily maintained; and
- 3.12 arranged such that liferafts may be securely attached to the platform and released from the platform by a person either in the liferaft or on the platform.

*Associated Inflatable Liferafts*

- 4. An inflatable liferaft used in conjunction with the marine escape system shall –
  - 4.1 conform with the requirements of Part 1 and Part 2 of Schedule 4 where applicable;
  - 4.2 be sited close to the system container but be capable of dropping clear of the deployed chute/slide and boarding platform;
  - 4.3 be capable of release from its stowage rack with arrangements which will enable it to be moored and inflated alongside the boarding platform;
  - 4.4 be capable of release from its stowage rack as an independent item of life-saving equipment;
  - 4.5 be provided with float free arrangements complying with the requirements of Part 8 of Schedule 4; and
  - 4.6 be provided with pre-connected or easily connected retrieving lines to the platform.

*Instructions and Information*

- 5. Instructions and information shall be in a form suitable for the training manual and in the instructions for on-board maintenance referred to in Schedule 14. Instructions and information shall be in English in a clear and concise form and shall include –
  - 5.1 a general description of the system;
  - 5.2 the installation arrangements;
  - 5.3 the operational instructions for the system, and associated survival craft;
  - 5.4 the on-board maintenance requirements; and
  - 5.5 the servicing requirements.

*Containers for marine evacuation systems*

- 6.1 The evacuation passage and platform shall be packed in a container that is –



- 6.1.1 so constructed as to withstand hard wear under conditions encountered at sea; and
- 6.1.2 as far as practicable watertight, except for drain holes in the container bottom.
- 6.2 The container shall be marked with:
  - 6.2.1 maker's name or trade mark;
  - 6.2.2 serial number;
  - 6.2.3 name of approval authority and the capacity of the system;
  - 6.2.4 SOLAS 1998;
  - 6.2.5 date of manufacture (month and year);
  - 6.2.6 date and place of last service;
  - 6.2.7 maximum permitted height of stowage above waterline; and
  - 6.2.8 stowage position on board.
- 6.3 Launching and operating instructions shall be marked on or in the vicinity of the container.

*Marking on marine evacuation systems*

- 7.1 The marine evacuation system shall be marked with –
  - 7.1.1 maker's name or trade mark;
  - 7.1.2 serial number;
  - 7.1.3 date of manufacture (month and year);
  - 7.1.4 name of approving authority;
  - 7.1.5 name and place of servicing station where it was last serviced, together with the date of servicing; and
  - 7.1.6 the capacity of the system.

**PART 2 – TRAINING**

- 1. Facilities for crew training in the use of marine escape systems shall include –
  - 1.1 the provision on board of an operational manual for the system and its associated inflatable liferafts;
  - 1.2 the provision of on-board training aids; and
  - 1.3 the provision ashore of a training course including, as far as is possible, practical exercises with full size equipment.

### PART 3 – MEANS OF RESCUE SYSTEM

1. The means of rescue system shall comply with the applicable requirements of Part 1 and also comply with the following requirements;
  - 1.1 the means of rescue shall provide for the safe transfer of persons rescued from the sea to the deck of the ship;
  - 1.2 the means of rescue shall provide an area of at least 9 square metres at water level to receive rescued persons;
  - 1.3 the means of rescue shall provide for the transfer of helpless persons to the deck of the ship;
  - 1.4 the rescue area into which the means of rescue is launched shall be adequately illuminated from the deck of the ship;
  - 1.5 the means of rescue shall be one of the following –
    - 1.5.1 a marine evacuation system complying with the requirements of Part 1, Schedule 5 providing a suitable floating platform, with a ladder or other means to ascend to the deck for able-bodied persons, and a mechanically powered means to safely hoist persons lying down. If a slide of a marine evacuation system is intended to provide the means of transfer from the platform to the deck of the ship for able-bodied persons, the slide shall be provided with suitable handholds or portable ladders with steps having an efficient non-slip surface;
    - 1.5.2 an appliance complying with the requirements for davit launched liferafts in Schedule 4, Part 1, paragraph 3.1; Part 2, paragraph 4.1.1 and Part 8, paragraph 1.1.1, and in the case of an inflatable appliance Schedule 4, Part 1, paragraphs 4.1 and 4.2; Part 2 paragraphs 2.1, 2.1.1, 2.1.2, 2.3, 2.4, 4.1.3, 4.1.3.1, 4.1.3.2 and 5.1 and Part 8 paragraph 1.12.1 or in the case of a rigid appliance Schedule 4, Part 1, paragraphs 4.1.1, 4.1.2 and 4.1.5 and Part 6, paragraphs 1, 2, 4.1.2, 4.1.6 and 5.1.1, to provide a suitable floating platform. The appliance shall be used with a liferaft launching appliance with a powered winch motor capable of raising the loaded appliance from the water to the deck of the ship with the total number of persons for which it is approved as a means of rescue at a rate of not less than 0.3 metres per second;
    - 1.5.3 the appliance provided for the launch and recovery of a fast rescue boat may be used as part of a means of rescue system provided it meets and does not conflict with any other relevant requirements.
  - 1.6 The means of rescue shall comply with the following –
    - 1.6.1 the appliance shall be of a highly visible colour, and shall be protected against damage when moving against the ship's side;
    - 1.6.2 the occupants shall be protected against injury caused by the launching appliance;
    - 1.6.3 two boarding ramps complying with Part 2, Schedule 4 paragraph 3.1 or Part 6, paragraph 3.1 shall be fitted;
    - 1.6.4 the floor shall be self-draining;
    - 1.6.5 suitable means shall be provided for bowing in the platform to the ship's side;

- 1.6.6** one knife of a type described in Part 8, Schedule 4 paragraph 1.1.2 shall be stowed in a pocket close to each bowing line attachment patch;
- 1.6.7** a special arrangement shall be fitted to close the gap between the loaded platform and the deck when the rescued persons board the ship;
- 1.6.8** the appliance shall be conspicuously marked to prevent confusion with liferafts;
- 1.6.9** if inflatable, the inflation system shall be quickly initiated by a manual control; and
- 1.6.10** means shall be provided for preventing occupants from falling from the platform on impact with the ship's side.

## SCHEDULE 6

### LAUNCHING APPLIANCES AND EMBARKATION LADDERS

#### PART 1 – GENERAL

##### *General Requirements*

- 1.1** With the exception of the secondary means of launching for free-fall lifeboats, each survival craft and rescue boat launching appliance, together with all its launching and recovery gear, shall be so arranged that the fully equipped survival craft or rescue boat it serves can be safely lowered at a list of up to 20 degrees either way and against a trim of up to 10 degrees –
- 1.1.1** after being boarded by its full complement of persons at the stowed position or from an embarkation deck, as appropriate; and
- 1.1.2** without persons in the survival craft or rescue boat.
- 1.2** Notwithstanding the requirements of paragraph 1.1, lifeboat launching appliances for oil tankers, chemical tankers and gas carriers with a final angle of heel greater than 20 degrees calculated, as appropriate, in accordance with –
- 1.2.1** regulation 29(3)(c) of the Merchant Shipping (Prevention of Oil Pollution) Regulations 1996 **(a)**;
- 1.2.2** paragraph 2.9.2.2 of the International Code for the Construction and equipment of Ships carrying Dangerous Chemicals in Bulk**(b)**; or
- 1.2.3** paragraph 2.9.1.2 of the International Code for the Construction and Equipment of Ships carrying Liquefied Gases in Bulk **(c)**;
- shall be capable of operating at the final angle of heel on the lower side of the ship taking into consideration the final damaged waterline of the ship.
- 1.3** Davits, winches, falls, blocks and all other launching gear shall comply with the requirements of Parts 2, 3 or 4.
- 1.4** On ships which regularly trade to Antarctica or North of the Arctic Circle or to sea areas where ice or icing-up conditions can be expected, each launching appliance shall, as far as practicable, remain effective under conditions of icing.
- 1.5** Every launching appliance for a lifeboat, rescue boat, liferaft or inflated boat shall be so constructed that a minimum amount of routine maintenance is necessary. All parts requiring regular maintenance by the ship's crew shall be readily accessible and easily maintained.
- 1.6** A launching appliance shall not depend on any means other than gravity or stored mechanical power which is independent of the ship's power supplies to launch the survival appliance or rescue boat it serves in, the fully loaded and equipped condition, and in the light condition. However, if the rescue boat is a dedicated rescue boat the mechanical power need not be independent of the ship's power supplies.

---

(a) S.I 1996/2154

(b) IMO Resolution MSC 4(48)

(c) IMO Resolution MSC 5(48)

## *Stresses*

2. Structural members and all blocks, falls, padeyes, links, fastenings and all other fittings used in connection with launching equipment shall be designed on the basis of a factor of safety calculated on the maximum working load assigned and the ultimate strength of the material used for construction. A minimum factor of safety of 4.5 shall be applied to the structural members of all davits and winches, and to bousing tackle and tricing pendants where they are required; and a minimum factor of safety of 6 shall be applied to falls, suspension chains, links and blocks.

## *Launching appliances using falls and a winch*

- 3.1 Launching appliances using falls and a winch, except for secondary launching appliances for free-fall lifeboats, shall also comply with the following:
  - 3.2 An efficient hand gear shall be provided to recover each survival craft, rescue boat and fast rescue boat.
  - 3.3 Where davit arms are recovered by power, safety devices shall be fitted which will automatically cut the power off before the arms reach their stops in order to avoid overstressing the falls or davits, unless the motor is designed to prevent such overstressing.
  - 3.4 A lifeboat launching appliance shall be capable of recovering and stowing the lifeboat with its launching crew.
  - 3.5 Every survival craft, rescue boat and fast rescue boat launching appliance shall be fitted with brakes, or equivalent devices, capable of stopping the descent of the survival craft or rescue boat and holding it securely when loaded with its full complement of persons and equipment; brake pads shall, where necessary, be protected from water and oil.
  - 3.6 Manual brakes shall be so arranged that the brake is always applied unless the operator, or a mechanism actuated by the operator, holds the brake control in the "OFF" position.
  - 3.7 Every rescue and fast rescue boat launching appliance shall be fitted with a winch motor of such capacity that the rescue boat, or a lifeboat if it has been accepted as a rescue boat, can be raised from the water with its full rescue boat complement of persons and equipment to a position where the persons can be safely disembarked.
  - 3.8 Rescue boat launching and recovery appliances arrangements shall –
    - 3.8.1 be capable of hoisting the rescue boat, or a lifeboat in rescue boat mode, when loaded with its full rescue boat complement of persons and equipment at a rate of not less than 0.3 metre per second;
    - 3.8.2 except in the case where a rescue boat is fitted with a single point suspension, every rescue boat shall be provided with the means for facilitating the attachment of the lower fall blocks to the lifting arrangements of the boat when the boat is recovered from the sea in adverse weather conditions. For this purpose a recovery strop of adequate strength and suitable length shall be provided for each davit, and one end of the strop shall be attached to the lower fall block and the other end to the lifting arrangement on the boat. In addition means shall be provided for hanging off the boat after hoisting to enable the lower fall block to be attached directly to the lifting hook.
  - 3.9 Fast rescue boat launching and recovery arrangements shall comply with the requirements of this Part as applicable and –

- 3.9.1 the launching appliance shall be fitted with a device to dampen the forces due to interaction with the waves when the fast rescue boat is launched or recovered. The device shall include a flexible element to soften shock forces and a damping element to cancel out oscillations;
- 3.9.2 the winch shall be fitted with an automatic high-speed tensioning device which prevents the wire from going slack in all sea state conditions in which the fast rescue boat is intended to operate;
- 3.9.3 the winch brake shall have a gradual action. When the fast rescue boat is lowered at full speed and the brakes are applied sharply the additional dynamical force induced in the wire due to retardation should not exceed 0.5 times the working load of the launching appliance;
- 3.9.4 the lowering speed for a fully equipped fast rescue boat with its full complement of persons on board shall not exceed 1 metre per second, the hoisting speed when lifting the fully equipped rescue boat loaded with 6 persons shall be not less than 0.8 metres per second. The appliance shall also be capable of lifting the rescue boat with the maximum number of persons that can be accommodated in the rescue boat as calculated under Part 2, Schedule 2 paragraph 2.3;
- 3.9.5 at least three turns of wire shall remain on the winch after the fast rescue boat is lowered to the sea with the ship at its lightest seagoing condition, a trim of up to 10 degrees and a list of up to 20 degrees, either way;
- 3.9.6 These arrangements shall take into account that the fast rescue boat is intended to be safely launched and retrieved even under severe adverse weather conditions.

#### *Wire ropes*

- 4.1 Falls shall be of rotation-resistant and corrosion-resistant steel wire rope.
- 4.2 The breaking tensile load of each wire rope used for lowering lifeboats, rescue boats, fast rescue boats, liferafts or inflated boats shall be not less than 6 times the maximum load on the wire rope when lowering, hoisting or stowing.
- 4.3 Wire ropes shall be securely attached to the drum of the winch, and the end attachments of the wires and other parts from which the craft is to be suspended shall be capable of withstanding a proof load of not less than 2.2 times the load on such attachments and other parts.
- 4.4 Where wire rope splices or ferrule-secured eye terminals are used they shall be capable of withstanding a proof test of not less than 2.2 times the load imposed on them in service.
- 4.5 Survival craft attached to davits shall have the falls ready for service, and the falls shall be at least long enough to reach the water with the ship at her lightest sea-going draught under unfavourable conditions of trim and listed to 20 degrees either way. Disengaging gear complying with the requirements of Part 1 of Schedule 2, shall be provided for detaching the lifeboat or rescue boat from the falls.

#### **Winches**

- 5.1 In the case of a multiple drum winch, unless an efficient compensatory device is fitted, the falls shall be so arranged to wind off the drums at the same rate when lowering, and to wind on the drums evenly at the same angle when hoisting. The lead blocks shall be arranged to give a fleet angle or angle of lead of not more than five degrees for grooved drums and three degrees for ungrooved drums. In the case of mechanically controlled single-arm davits, the lead of the wire rope fall shall be such that the fall winds evenly on the drum.

- 5.2 Winch brakes shall be of robust construction and be capable of controlling and limiting the speed a boat is lowered. The hand brake shall be so arranged that it is normally in the "ON" position and returns to the "ON" position when the control handle is not being operated. The mass of the brake lever shall be sufficient to operate the brake effectively without additional pressure. The winch brakes shall be of sufficient strength to withstand –
- 5.2.1 a static test with a proof load of not less than 1.5 times the maximum working load; and
- 5.2.2 a dynamic test with a proof load of not less than 1.1 times the maximum working load at maximum lowering speed.
- 5.3 The speed at which a fully laden lifeboat, rescue boat, liferaft or inflated boat with its equipment and launching crew is lowered into the water shall be not less than that obtained from the formula –
- $$S = 0.4 + (0.02 \times H)$$
- where S = speed of lowering in metres per second, and
- H = height in metres from davit head, at the outboard position, to the waterline at the lightest seagoing condition.
- In the case of a lifeboat, rescue boat or inflated boat where "H" exceeds 30 metres the lowering speed need not exceed 1 metre per second. In the case of a liferaft where "H" exceeds 15 metres the lowering speeds need not exceed 0.7 metres per second.
- 5.4 Notwithstanding the requirements of paragraph 5.3 the speed of lowering a lifeboat, rescue boat or inflated boat shall not exceed 1.3 metres per second. The speed of lowering a liferaft shall not exceed 1 metre per second.
- 5.5 The speed of lowering survival craft, fully equipped but without persons on board, shall be at least 70 per cent of that required by paragraph 5.3.
- 5.6 The brake gear of the winch shall include the means for automatically controlling the speed of lowering to within the limits specified in paragraphs 5.3 and 5.4. A ratchet gear shall be incorporated in these winches.
- 5.7 Hand gear handles shall not be rotated by moving parts of the winch when the lifeboat or rescue boat is being lowered or when it is being hoisted by power. Provision shall be made to allow the falls to be manually unwound.
- 5.8 The launching mechanism shall be so arranged that it may be actuated by one person from a position on the ship's deck and, except for secondary launching appliances for free-fall lifeboats, from a position within the survival craft or rescue boat. When launched by a person on the deck, the launching and recovery arrangements shall be such that the winch operator on the ship's deck is able to observe the craft at all times during launching and recovery.
- 5.9 In this case of a liferaft, if the lowering is actuated from within the raft by means of a control wire paid off from an auxiliary drum on the winch –
- 5.9.1 the mass of the control wire shall be sufficient to overcome the friction of the various pulleys on the control wire;
- 5.9.2 the winch brake shall be operable from within the liferaft;

- 5.9.3 the winch brake shall not be affected by the mass of the fully extended control wire nor the wind effects on it; and
  - 5.9.4 there shall be sufficient length of control wire available at the craft during all stages of lowering.
- 5.10 When the lowering of the lifeboat or rescue boat is controlled from within the craft by means of a control wire paid off from an auxiliary drum on the winch –
- 5.10.1 the mass of the control wire shall be sufficient to overcome the friction of the various pulleys on the control wire, when turning out the lifeboat or rescue boat from the stowed position;
  - 5.10.2 the winch brake shall be operable from within the boat;
  - 5.10.3 the winch brake shall not be affected by the mass of the fully extended control wire, nor the wind effects on it;
  - 5.10.4 there shall be sufficient length of control wire available at the boat during stages of lowering; and
  - 5.10.5 means shall be provided to retain the free end of the control wire in the boat until the boat is detached from the falls.

*Float-free launching*

6. Where a survival craft requires a launching appliance and is also designed to float free, the float-free release of the survival craft from its stowed position shall be automatic.

*Free-fall launching*

- 7.1 Every free-fall launching appliance using an inclined plane shall, in addition to complying with the applicable requirements of paragraph 1 also comply with the following requirements –
- 7.1.1 the launching appliance shall be so arranged that excessive forces are not experienced by the occupants of the survival craft during launching;
  - 7.1.2 the launching appliance shall be a rigid structure with a ramp angle and length sufficient to ensure that the survival craft effectively clears the ship;
  - 7.1.3 the launching appliance shall be efficiently protected against corrosion and be so constructed as to prevent incendive friction or impact sparking during the launching of the survival craft;
  - 7.1.4 The launching appliance shall be designed and arranged so that in its ready to launch position, the distance from the lowest point on the lifeboat it serves to the water surface with the ship in its lightest seagoing condition does not exceed the lifeboat's free-fall certification height taking into consideration the requirements of paragraph 3, Part 9, Schedule 2;
  - 7.1.5 The launching appliance shall be arranged so as to preclude accidental release of the lifeboat in its unattended stowed position. If the means provided to secure the lifeboat cannot be released from inside the lifeboat, it shall be so arranged as to preclude boarding the lifeboat without first releasing it;
  - 7.1.6 The release mechanism shall be arranged so that at least two independent actions from inside the lifeboat are required in order to launch the lifeboat;



- 7.1.7 Each launching appliance shall be provided with a secondary means to launch the lifeboat by falls. Such means shall comply with the requirements of Section 1 except paragraph 1.6 and Section 3 except paragraph 3.2. It must be capable of launching the lifeboat against unfavourable conditions of trim of up to only 2 degrees and list of up to only 5 degrees either way and it need not comply with the speed requirements of paragraphs 5.3 and 5.4. If the secondary launching appliance is not dependent on gravity, stored mechanical power or other manual means, the launching appliance shall be connected both to the ship's main and emergency power supplies; and
- 7.1.8 The secondary means of launching shall be equipped with at least a single off-load capability to release the lifeboat.

*Evacuation- passage launching and embarkation*

8. Every evacuation-passage launching appliance shall, in addition to complying with the applicable requirements of paragraph 1, also comply with the requirements of Schedule 5.

*Means of rescue launching and embarkation*

9. Every means of rescue launching and recovery appliance shall; in addition to complying with the applicable requirements of Part 1; also comply with the requirements of Part 3, Schedule 5.

*Instructions and Information*

- 10.1 Instructions and information shall be in a form suitable for the training manual and in the instructions for on-board maintenance referred to in Schedule 14. Instructions and information shall be in English in a clear and concise form and shall include the following –
- 10.1.1 a description of launching appliance and winch, were provided;
- 10.1.2 the operation for launching and recovery; and
- 10.1.3 the maintenance required.

Small Passenger Ship Regulations  
regs 5 and 6

Other Ships Regulations  
regs 7, 8, 9, 42, 43, 44, 45, 46, 47  
63, 64, 65, 66, 68 and 69

**PART 2 – LIFEBOAT AND RESCUE BOAT LAUNCHING APPLIANCES**

*General*

- 1.1 Every lifeboat, rescue boat and fast rescue boat launching appliance shall comply with the requirements of Part 1 as is applicable to it and, in addition, shall comply with the requirements of this Part.
- 1.2 In this Part the expression “working load” means –
- 1.2.1 in relation to davits to which paragraphs 2.1 and 2.2 apply, the sum of the weight of the lifeboat and its full equipment, the blocks and falls, and the maximum number of persons which the lifeboat is deemed fit to carry, the weight of each person being taken to be 75 kilogrammes; and
- 1.2.2 in relation to winches, the maximum pull exerted by the fall or falls at the winch drum during lowering, hoisting or stowing which in any case is to be taken as not less than the working load on the davit or davits divided by the velocity ratio of the lowering tackle.

## *Construction*

- 2.1 The arrangements of the davits shall be such as to enable safe boarding of the lifeboat in accordance with the requirements of paragraph 2.4 and 2.5 of Part 2 of Schedule 2.
- 2.2 If partially enclosed lifeboats are carried, a davit span shall be provided, fitted with not less than two lifelines of sufficient length to reach the water with the ship in its lightest seagoing condition, under unfavourable conditions of trim and with the ship listed not less than 20 degrees either way.

## *Strength*

- 3.1 Every davit serving a lifeboat which is required to be boarded and launched from the stowed position and put into the water when loaded with its full complement of persons shall, together with its winch, falls, blocks and all other associated equipment, be of such strength that the lifeboat with its full equipment can be turned out and then safely lowered into the water from the stowed position with its full complement of persons, when the ship has a list of up to 20 degrees either way and a trim up to 10 degrees or such greater angles as may be required under paragraph 1.2 of Part 1.
- 3.2. Every davit serving a lifeboat which is required to be boarded and launched from an embarkation position and put into the water when loaded with its full complement of persons shall, together with its winch, falls, blocks and all other associated lowering gear, be of such strength that the lifeboat with its full equipment and manned by a launching crew of not less than 2 persons can be turned out and then safely lowered into the water from the embarkation position with its full complement of persons, when the ship has a list of up to 20 degrees either way and a trim of up to 10 degrees.
- 3.3 Every set of davits, davit or other means of launching to which a lifeboat is attached, together with its winch and associated gear shall be of such strength that the lifeboat can be hoisted with launching crew of at least 3 persons and its full equipment at a rate of not less than 0.05 metre per second when a powered winch is fitted. When an unpowered winch is fitted the hoisting rate shall be not less than 0.01 metre per second.
- 3.4 Every set of davits, davit or other means of launching to which a rescue boat is attached shall be fitted with a powered winch and shall, together with its associated gear, be of such strength that the boat to which it is attached can be hoisted when loaded with its full rescue boat complement of persons and equipment at a rate of not less than 0.3 metre per second. When a lifeboat is designated as a rescue boat, the davits, davit or other means of launching shall be capable of hoisting the boat to a disembarkation position at a rate of not less than 0.3 metre per second when loaded with its full rescue boat complement, or 6 persons whichever is the greater, and its full lifeboat equipment.
- 3.5 Every fast rescue boat launching and recovery arrangement shall incorporate a powered winch, dampening devices and braking requirements described in Part 1 paragraph 3.9 and be capable of lowering the fully equipped boat with its full complement of persons at a speed not exceeding 1 metre per second and hoisting the fully equipped boat loaded with 6 persons at a speed of at least 0.8 metres per second. The arrangement shall also be capable of lifting the rescue boat with the maximum number of persons accommodated. The complete arrangement shall be of adequate strength to withstand the stresses developed in the system carrying out these operations safely under severe adverse weather conditions.

## *Gravity davits*

4. All gravity davits shall be so designed that there is a positive turning out moment during the whole of the davit travel from the inboard to the outboard position when the vessel is upright and also when the vessel is listed at any angle up to and including 30 degrees either way from upright, or 10 degrees more than the angle required by paragraph 1.2 of Part 1. In the case of gravity type davits

comprising arms mounted on rollers which engage with and travel down fixed inclined trackways, the trackways shall be inclined at an angle of not less than 35 degrees to the horizontal when the vessel is upright.

#### *Luffing davits*

- 5 The operating gear of luffing davits shall be of sufficient power to ensure that the lifeboats or rescue boats fully equipped and carrying –

5.1.1 the total number of persons they are certified to carry; or

5.1.2 a launching crew of not less than 2 persons when boarded from a stowed position or embarkation deck;

can be turned out against a list of at least 20 degrees.

#### *Static load test*

6. Each davit arm and its attachments, except the winch brakes, shall be capable of withstanding a static load test when in the outboard position, of at least 2.2 times the maximum load designed to be supported by that arm.

#### *Attachments at the davit head*

7. The attachments at the davit head from which the blocks are suspended shall be capable of withstanding a proof load test of not less than 2.2 times the maximum load on them.

#### *Blocks*

8.1 Lower blocks, when fitted, shall be non-toppling. In the case of rescue boats provision shall be made to prevent the falls from cabling. The size of blocks shall be commensurate with the size of the falls.

8.2 The blocks shall be capable of withstanding a proof load test of not less than 2.2 times the maximum load it is intended to carry in service. The clearance between the sheaves and the cheeks of the blocks in which wire rope is used shall be kept to a practical minimum to prevent the rope from overriding the rim of the sheave of any block or load sheave. Component parts of blocks other than their sheaves shall be of ductile material.

Small Passenger Ship Regulations  
regs 5 and 6

Other Ships Regulations  
regs 7, 8, 9, 42, 43, 44, 45  
63, 64, 65 and 66

### **PART 3 – LIFERAFT LAUNCHING APPLIANCES**

#### *General*

1.1 Every launching appliance shall comply with the requirements of Part 1 as is applicable to it and in addition shall comply with the requirements of this Part.

1.2 In this Part the expression “working load” means the sum of the mass of the liferaft and its equipment, all other associated gear that is supported by the launching appliance during the lowering operation and the maximum number of persons which the liferaft is deemed fit to carry, the mass of each person being taken to be 75 kilogrammes.

1.3 The arrangements of the launching appliance shall be such as to enable safe boarding of the liferaft in accordance with the requirements of paragraph 4.3 and 4.4 of Part 2 of Schedule 4.

### *Strength*

2. Every launching appliance serving a liferaft which is required to be put into the water when loaded with its full complement of persons shall, together with its winch, falls, blocks and all other associated launching equipment, be of such strength that the liferaft with its full equipment can be safely lowered into the water from the embarkation position with its full complement of persons, when the ship has a list of up to 20 degrees either way and a trim of up to 10 degrees, or such higher angle as may be required by paragraph 1.2 of Part 1.

### *Static load test*

3. Every launching appliance and its attachments, except the winch brakes, shall be capable of withstanding a static load test when in the full outboard position, of at least 2.2 times the maximum designed working load.

### *Release of the liferaft*

4. The launching appliance shall be so arranged as to prevent premature release during the lowering of the liferaft but shall be such that on becoming waterborne the raft shall be automatically released from the release hook which shall comply with requirements of Part 7 of Schedule 4.

**Small Passenger Ship Regulation**  
regs 5 and 6

**Other Ships Regulations**  
regs 42, 43, 44, 46, 47  
63, 64, 65, 67 and 68

## **PART 4 – INFLATED BOAT LAUNCHING APPLIANCES**

### *General*

- 1.1 Every inflated boat launching appliance shall comply with the requirements of Part 1 as is applicable to it and in addition with the requirements of this Part.
- 1.2 In this Part the expression “working load” means the weight of –
  - 1.2.1 the inflated boat and its full equipment;
  - 1.2.2 the blocks and falls;
  - 1.2.3 a launching crew of 2 persons each of mass 75 kilogrammes; and
  - 1.2.4 a weight of 60 kilogrammes or the engine together with its fuel tank and sufficient fuel for two hours operation, whichever is the greater.
- 1.3 In this Part the expression “inflated boat” means any inflated boat or rigid inflated boat other than a dedicated rescue boat.

### *Construction*

2. Every inflated boat launching appliance shall be so constructed to be –
  - 2.1 capable of recovering the inflated boat and bringing it on board the ship;
  - 2.2 readily available and not stowed or used for any purpose other than the launching of the inflated boat whilst the ship is at sea; and
  - 2.3 provided with a suitable means for manual operation.

### *Strength*

3. Every launching appliance serving an inflated boat shall, together with its winch if fitted, falls, blocks and other associated lowering gear, be of such strength that the inflated boat with its full equipment can be safely lowered into the water from the embarkation position with a complement of 2 persons, when the ship has a list of up to 20 degrees either way and a trim of up to 10 degrees.

### *Static load test*

4. Every launching appliance and its attachments, except the winch brakes, shall be capable of withstanding a static load test when in the full outboard position of at least 2.2 times the maximum designed working load.

### *Winches*

5. Every such launching appliance shall be provided with a winch when the inflated boat is situated more than 4.5 metres above the lightest sea going waterline.

### *Cordage rope falls*

- 6.1 Cordage rope falls shall be of manila or some other suitable material and shall be durable, uninkable, firm laid and pliable. They shall be able to pass freely under any conditions through a hole 10 millimetres larger than the nominal diameter of the rope. The breaking load of each rope used for lowering inflated boats shall be not less than 6 times the maximum load on the rope when lowering or hoisting. Winding reels or flaking boxes for the manila rope falls shall be provided.
- 6.2 Such falls shall be at least long enough to reach the water with the ship at her lightest seagoing condition and listed to 20 degrees either way.

### *Bollards*

7. Suitable bollards or other equally effective appliances for lowering any inflated boat shall be provided in all cases where cordage rope falls are used. Such bollards or other appliances shall be sited so as to ensure that the inflated boat served by them can be safely lowered, the fairleads or lead sheaves shall be fitted so as to ensure that it shall not be lifted during the process of turning out or swinging out.

Small Passenger Ship Regulations  
reg 13

Other Ships Regulations  
regs 50 and 71

## **PART 5 – EMBARKATION LADDERS**

### *Construction*

- 1.1 The steps of the three string embarkation ladder applicable for Class III to VI(A) shall be –
  - 1.1.1 made of hardwood, free from knots or other irregularities, smoothly machined and free from sharp edges and splinters, or of suitable material of equivalent properties;
  - 1.1.2 provided with an efficient non-slip surface either by longitudinal grooving or by the application of an approved non-slip coating;
  - 1.1.3 not less than 1370 millimetres long, 115 millimetres wide and 25 millimetres in depth, excluding any non-slip surface or coating; and
  - 1.1.4 equally spaced not less than 300 millimetres or more than 380 millimetres apart and secured in such a manner that they will remain horizontal.

- 1.2** The side and centre ropes of the three string embarkation ladder shall consist of two parts of uncoiled 20 millimetres diameter good quality manila ropes.
- 1.3** The steps for the two string embarkation ladder, applicable to Ships Other than Classes III to VI(A) Regulations, shall be:
- 1.3.1** made of hardwood, free from knots or other irregularities, smoothly machined and free from sharp edges and splinters, or of suitable material of equivalent properties;
  - 1.3.2** provided with an efficient non-slip surface either by longitudinal grooving or by the application of an approved non-slip coating;
  - 1.3.3** not less than 480 millimetres long, 115 millimetres wide and 25 millimetres in depth, excluding any non-slip surface or coating; and
  - 1.3.4** equally spaced not less than 300 millimetres or more than 380 millimetres apart and secured in such a manner that they will remain horizontal.
- 1.4** The side and centre ropes of the two string embarkation ladder shall consist of two parts of uncoiled 20 millimetres diameter good quality manila ropes.

## SCHEDULE 7

### PYROTECHNIC SIGNALS AND LINE-THROWING APPLIANCES

#### PART 1 – GENERAL

##### *General*

1. A pyrotechnic signal shall –

- 1.1 be constructed with proper workmanship and materials;
- 1.2 not be damaged in stowage in the air temperature range of  $-30^{\circ}\text{C}$  to  $+65^{\circ}\text{C}$ ;
- 1.3 be contained in a water-resistant casing;
- 1.4 have integral means of ignition which can be readily operated with wet, cold or gloved hands in adverse conditions and require the minimum of preparation;
- 1.5 in the case of a rocket parachute flare or a hand flare be so designed that, when used in accordance with the manufacturer's operating instructions, it shall not cause discomfort to the person holding the casing or endanger a liferaft by burning or glowing residues;
- 1.6 in the case of a buoyant smoke signal be so designed that it shall not ignite explosively when used in accordance with the manufacturer's operating instructions;
- 1.7 be so constructed that any sealing shall not depend on adhesive tapes, or plastic envelopes;
- 1.8 be so constructed that the end from which the rocket is ejected can be positively identified by day or night;
- 1.9 be so constructed that all components, compositions and ingredients of the signal and the means of igniting it shall be of such character and quality to enable the signal to maintain its serviceability under good average storage conditions in the marine environment for a period of at least 4 years; and
- 1.10 be so constructed that if it is intended to be stowed in a liferaft it can function effectively after being subjected to a drop test appropriate to the height at which the liferaft is to be stowed, when the signal is packed in the equipment container.

##### *Marking*

- 2.1 A pyrotechnic signal shall have printed on its casing brief instructions or diagrams clearly illustrating how it is to be used.
- 2.2 The date of manufacture and the date of expiry shall be marked indelibly on the casing.

## PART 2 – ROCKET PARACHUTE FLARES

### *General*

1. Every rocket parachute flare shall comply with the requirements of Part 1 and in addition shall comply with the requirements of this Part.

### *Performance*

2. A rocket shall, when fired vertically, reach an altitude of not less than 300 metres. At or near the top of its trajectory, the rocket shall eject a parachute flare, which shall –
  - 2.1 burn with a bright red colour;
  - 2.2 burn uniformly with an average luminous intensity of not less than 30,000 candela;
  - 2.3 have a burning period not less than 40 seconds;
  - 2.4 have a rate of descent of not more than 5 metres/second; and
  - 2.5 not damage its parachute or attachments while burning.
3. The rocket shall in addition be capable of functioning when the rocket is fired at an angle of 45 degrees to the horizontal.

Other Ships Regulations  
regs 23, 63, 64, 65, 66, 67, 68 and 69  
Schedule 2 Part 4  
Schedule 4 Part 2

## PART 3 – HAND FLARES

### *General*

1. Every flare shall comply with the requirements of Part 1 and in addition shall comply with the requirements of this Part.

### *Performance*

2. A hand flare shall –
  - 2.1 burn with a bright red colour;
  - 2.2 burn uniformly with an average luminous intensity of not less than 15,000 candela;
  - 2.3 have a burning period of not less than 1 minute; and
  - 2.4 after ignition continue to burn after having been immersed for a period of 10 seconds under 100 millimetres of water.



## PART 4 – BUOYANT SMOKE SIGNALS

### *General*

1. Every buoyant smoke signal shall comply with the requirements of Part 1 and in addition with the requirements of this Part.

### *Performance*

2. A buoyant smoke signal shall –
  - 2.1 emit smoke of a highly visible colour at a uniform rate for a period of not less than 3 minutes when floating in calm water;
  - 2.2 not emit any flame during the entire smoke emission time;
  - 2.3 not be swamped in a sea-way; and
  - 2.4 continue to emit smoke when submerged in water for a period of 10 seconds under 100 millimetres of water.
3. It shall be safe to operate in water covered by a low flash point liquid.

Small Passenger Ship Regulations  
regs 5 and 6

Other Ships Regulations  
regs 7, 8, 10, 11, 20, 21  
42, 43, 44, 45, 47, 48  
63, 64, 65, 66, 67, 68, and 69

## PART 5 – LINE-THROWING APPLIANCES

### *Construction*

1. A line-throwing appliance shall –
  - 1.1 be constructed with proper workmanship and materials;
  - 1.2 in the case of an integral rocket and line, be contained in a water-resistant casing; in the case of a pistol fired rocket, the rocket shall be contained in a water-resistant casing;
  - 1.3 include not less than four projectiles;
  - 1.4 include not less than four lines each having a breaking strength of not less than 20 kiloNewtons; and
  - 1.5 be so designed that the end from which the rocket is ejected can be positively identified by day or night.
2. Rockets, cartridges and igniters shall be so constructed that all components, compositions and ingredients shall be of such character and quality to maintain serviceability under good average storage conditions in the marine environment for a period of at least 4 years.
3. Rockets, cartridges and igniters shall be so constructed that any sealing shall not depend on adhesive tapes or plastic envelopes.

### *Performance*

- 4.1 A line-throwing appliance shall be capable of throwing a line not less than 4 millimetres in diameter a distance of at least 230 metres in calm weather.
- 4.2 A line-throwing appliance shall be capable of throwing a line in such a manner that the lateral deflection on either side of the direction of firing does not exceed 10 per cent of the length of flight of the rocket in calm weather.

### *Marking*

- 5.1 A line-throwing appliance shall be marked with brief instructions or diagrams clearly illustrating the use of the appliance.
- 5.2 The date of manufacture and the date of expiry shall be marked indelibly on the rockets, cartridges and igniters.

## **PART 6 – INFORMATION INSTRUCTIONS AND STOWAGE**

- 1. Instructions and information for pyrotechnic signals shall be in a form suitable for the training manual referred to in Schedule 14. Instructions and information shall be in English in a clear and concise form and shall include –
  - 1.1 a description of the item;
  - 1.2 the method of its use, including any precautions or warnings;
  - 1.3 its stowage;
  - 1.4 guidance on when it is to be used; and
  - 1.5 instructions for replacing rockets, cartridges or strikers (integral line-throwing appliance).

## SCHEDULE 8

### LIFEBUOYS AND ATTACHMENTS

#### PART 1 – GENERAL

##### *General*

1. Every lifebuoy and its attachments required by Regulation, shall comply with the requirements of Schedule 1 as are applicable to it.

##### *Instructions and information*

2. In the case of lifebuoy self-igniting lights or self-activating smoke signals, instructions and information shall be in a form suitable for the training manual and, if appropriate, the instructions for on-board maintenance referred to in Schedule 14. Instructions and information shall be in English in a clear and concise form and shall include –
  - 2.1 the stowage and attachments to the lifebuoy;
  - 2.2 the type of energy source if provided and, if replaceable, the method and frequency of its replacement;
  - 2.3 the type of light source if provided and whether it is replaceable;
  - 2.4 any maintenance requirements including the method and frequency of checking the of the energy source if one is provided; and
  - 2.5 the operation of the light or signal and its duration.

#### PART 2 – LIFEBUOYS (SOLAS)

##### *Construction*

- 1.1 A lifebuoy shall have an outer diameter of not more than 800 millimetres and an inner diameter of not less than 400 millimetres.
- 1.2 A lifebuoy shall be constructed of inherently buoyant material. It shall not depend for buoyancy upon rushes, cork shavings, granulated cork, any other loose granulated material or an air compartment.
- 1.3 It shall have a mass of not less than 2.5 kilogrammes: except that if it is to operate a quick release arrangement for a self-activating smoke signal and self-igniting light it shall have a mass sufficient to operate the arrangement or 4 kilogrammes, whichever is the greater.
- 1.4 It shall be constructed to withstand a drop into water from the height at which it is stowed above the waterline in the lightest seagoing conditions or 30 metres, whichever is the greater, without impairing either its operating capability or that of its attached components.

- 1.5 It shall be fitted with a grabline of not less than 9.5 millimetres in diameter and of length not less than 4 times the outside diameter of the lifebuoy. The grabline shall be secured at four equidistant points around the circumference of the lifebuoy to form four equal loops.

#### *Performance*

- 2.1 A lifebuoy shall be capable of supporting not less than 14.5 kilogrammes of iron in fresh water for period of 24 hours.
- 2.2 It shall not sustain burning or continue melting after being totally enveloped in a fire for a period of 2 seconds.

#### *Marking*

- 3.1 A lifebuoy shall be marked in block capitals with the name and the port of registry of the ship on which it is carried.
- 3.2 A lifebuoy shall be permanently marked with the maximum height above the waterline at which it can be stowed if this exceeds 30 metres.

**Other Ships Regulations**  
regs 46, 47, 68 and 69

### **PART 3 – LIFEBOUYS (610 millimetres)**

1. Every lifebuoy (610 millimetres) shall comply with requirements of Part 1 and 2: except that in paragraph –
- 1.1 it shall have outer diameter of not less than 610 millimetres and an inner diameter of not less than 350 millimetres;
- 1.2 it shall have a mass of not less than 1.3 kilogrammes;
- 1.3 the lightest seagoing condition should be taken to be 10 metres; and
- 1.4 the grabline should not be less than 6 millimetres in diameter.

**Small Passenger Ship Regulations**  
regs 6, 7, and 9

**Other Ships Regulations**  
regs 42, 43, 44, 45, 46, 47, 48  
63, 64, 65, 66, 67, 68 and 69

### **PART 4 – LIFEBOUY SELF-IGNITING LIGHTS**

#### *Construction*

- 1.1 It shall be constructed to withstand a drop into the water from the height at which it is stowed above the waterline in the lightest seagoing condition or 30 metres, whichever is the greater, without impairing either its operating capability or that of the lifebuoy to which it is attached.
- 1.2 It shall be provided with means for being efficiently attached to a lifebuoy.
- 1.3 A lifebuoy self-igniting light attached to a lifebuoy carried by tanker shall be of an electric battery type.
- 1.4 Components of electronic circuits should comply with the quality control requirements of BS 9000 or an equivalent standard. Where components cannot be obtained under one of the

above standards these components may be covered by a Certificate of Conformance from the manufacturer of the components.

### *Performance*

- 2.1 A lifebuoy self-igniting light shall be such that it cannot be extinguished by water.
- 2.2 It shall be capable of either burning continuously with a luminous intensity of not less than 2 candela in all directions of the upper hemisphere or flashing (discharge flashing) at a rate of not less than 50 flashes and not more than 70 flashes per minute with at least the corresponding effective luminous intensity and be provided with a source of energy which will give this performance for a period of at least 2 hours.
- 2.3 It shall be capable of withstanding the drop test required by Part 2 paragraph 1.4.

### *Marking*

3. A lifebuoy self-igniting light shall be marked indelibly with –
  - 3.1 the manufacturer's name or trade mark;
  - 3.2 clear and concise directions for use in English supported where necessary by illustrations;
  - 3.3 the type of energy source;
  - 3.4 the date of manufacture and expiry in the case of a light with a non-replaceable energy source; and
  - 3.5 the maximum height above waterline at which it can be stowed.

**Small Passenger Ship Regulations**  
regs 5, 6, 7, 8 and 9

**Other Ships Regulations**  
regs 24, 42, 43, 44, 45, 46, 47, 48  
63, 64, 65, 66, 67, 68, and 69

## **PART 5 – LIFEBOUY SELF-ACTIVATING SMOKE SIGNALS**

### *Construction*

- 1.1 It shall be constructed to withstand a drop into the water from the height at which it is stowed above the waterline in the lightest seagoing condition or 30 metres, whichever is the greater, without impairing either its operating capability or that of the lifebuoy to which it is attached.
- 1.2 It shall be provided with means for being efficiently attached to a lifebuoy.
- 1.3 A lifebuoy self-activating smoke signal may also be provided with a self-igniting light which shall comply with the requirements of Part 4.

### *Performance*

- 2.1 A lifebuoy self-activating smoke signal shall emit smoke of a highly visible colour at a uniform rate for a period of at least 15 minutes when floating in calm water.
- 2.2 It shall not ignite explosively or emit any flame during the entire smoke emission time of the signal.
- 2.3 It shall not be swamped in a sea-way.

- 2.4 It shall continue to emit smoke when fully submerged for a period of at least 10 seconds.
- 2.5 It shall be capable of quick release from its stowed position.
- 2.6 It shall be safe to operate in waters covered by a low flashpoint liquid.
- 2.7 All components, composition and ingredients of the lifebuoy self-activating smoke signal, and the energy source of the self-igniting light, if provided, shall be of such character and quality as to enable them to maintain their serviceability under good average stowage conditions in the marine environment for a period of at least four years unless, in the case of a self-igniting light energy source, it is possible to readily renew the energy source.

### *Marking*

3. A lifebuoy self-activating smoke signal shall be marked indelibly with –
  - 3.1 the manufacturer's name or trade mark;
  - 3.2 the lot number or other means of identifying the signal;
  - 3.3 clear and concise directions for use in English supported where necessary by illustrations;
  - 3.4 the date of manufacture and date of expiry;
  - 3.5 the type of energy source in the case of a signal provided with a self-activating light; and
  - 3.6 the maximum height above the waterline at which it can be stowed.

**Small Passenger Ship Regulations**  
regs 5, 6, 7, 8 and 9

**Other Ships Regulations**  
regs 42, 43, 44, 45, 46, 47, 48  
63, 64, 65, 66, 67, 68, and 69

## **PART 6 – LIFEBOUY BUOYANT LIFELINES**

### *Construction*

- 1.1 A lifebuoy buoyant lifeline shall be non-kinking.
- 1.2 It shall have a diameter of not less than 8 millimetres.
- 1.3 It shall have a breaking strength of not less than 5 kiloNewtons.
- 1.4 It shall be resistant to deterioration from exposure to sunlight.
- 1.5 It shall have a length not less than twice the height at which it is stowed above the waterline in the lightest seagoing condition, or 30 metres, whichever is the greater. On ships of less than 12 metres in length the lifeline shall be at least 18 metres in length.

## SCHEDULE 9

### LIFEJACKETS AND ATTACHMENTS

#### PART 1 – GENERAL

##### *General*

1. Every lifejacket and its attachment required by Regulations shall comply with the requirements of Schedule 1 as is applicable to it.

##### *Construction*

- 2.1 A lifejacket shall be so constructed that –
  - 2.1.1 at least 75 per cent of persons, who are completely unfamiliar with the lifejacket, can correctly don it within a period of one minute without assistance, guidance or prior demonstration;
  - 2.1.2 after a demonstration, all persons can correctly don it within a period of 1 minute without assistance;
  - 2.1.3 it is capable of being worn inside out or, if that is not the case, it is clear that it can be worn only in one way and, as far as is possible, it cannot be donned incorrectly;
  - 2.1.4 it is comfortable to wear; and
  - 2.1.5 it allows the wearer to jump from a height of at least 4.5 metres into the water without injury and without dislodging or damaging the lifejacket.
- 2.2 It shall be so constructed that the buoyancy is not reduced by more than 5 per cent after 24 hours submersion in fresh water.
- 2.3 It shall be fitted with a whistle firmly secured by a cord of suitable length. The whistle shall be non-metallic and not be affected by water or humidity.
- 2.4 It shall be fitted with retro-reflective material to assist detection, and the dimensions and location of the material shall be such as to meet this objective.
- 2.5 It shall be fitted with a ring or loop or similar device of adequate strength to facilitate rescue.
- 2.6 It shall be fitted with an approved light if it is intended for a ship which is required to carry lifejackets fitted with lights.

##### *Performance*

- 3.1 It shall have sufficient buoyancy and stability in calm fresh water to –
  - 3.1.1 lift the mouth of an exhausted or unconscious person not less than 120 millimetres clear of the water with the body inclined backwards at an angle of not less than 20 degrees and not more than 50 degrees from the vertical position; and

- 3.1.2 turn the body of an unconscious person in the water from any position to one where the mouth is clear of the water in not more than 5 seconds.
- 3.2 An inherently buoyant lifejacket shall allow the person wearing it to swim a short distance and to board a survival craft.
- 3.3 The buoyancy of the lifejacket shall not reduce by more than 5 per cent after 24 hours submersion in fresh water.
- 3.4 It shall not sustain burning or continue melting after being totally enveloped in a fire for a period of 2 seconds.

### *Marking*

- 4. A lifejacket shall be marked indelibly with –
  - 4.1 the manufacturer's name or trade mark and the name of the lifejacket, if any;
  - 4.2 the words "PERSON OF 32 KG OR MORE" in letters not less than 12 millimetres in size on the front in the case of inflatable lifejackets and on both sides in the case of lifejackets which can be worn inside out. In the case of lifejackets which can only be worn one way the marking shall be on the outside of the lifejacket;
  - 4.3 the year of manufacture or, in the case of an inflatable lifejacket, the means to identify the date of manufacture;
  - 4.4 the word "FRONT" on both sides of the front part of the lifejacket in letters not less than 12 millimetres in size in the case of lifejackets which can be worn inside-out. In the case of lifejackets which can only be worn one way the marking shall be on the outside of the front part of the lifejacket.

### *Lifejacket Lights*

#### *Construction*

- 5.1.1 The complete light unit shall be constructed with proper workmanship and materials. The materials shall be compatible with materials used in the construction of a lifejacket and with an immersion suit designed to be worn with a lifejacket.
- 5.1.2 The unit shall be rot-proof, corrosion-resistant and not be unduly affected by seawater, oil or fungal attack.
- 5.1.3 The unit shall not have any adverse effect on the performance of the lifejacket or immersion suit to which it is attached.
- 5.1.4 Each component of the unit shall be designed to remain serviceable for at least as long as the storage life of the power source.
- 5.1.5 The unit shall be so designed that it will not leak any substance which would be harmful to the lifejacket, immersion suit or wearer.
- 5.1.6 A flashing light shall be provided with a manually operated switch.
- 5.1.7 A flashing light shall not be fitted with a lens or curved reflector to concentrate the beam.
- 5.1.8 Components of electric circuits shall comply with the quality control requirements of



ISO 9000 or an equivalent standard. Where components cannot be obtained under one of the above standards these components shall be covered by a Certificate of Conformance from the manufacturer of the components.

#### *Attachment*

- 5.2.1 The method of attachment shall not require penetration of a lifejacket's buoyancy material or adversely affect the watertight integrity of an immersion suit.
- 5.2.2 The method of attachment shall be such that the light cannot become accidentally detached.
- 5.2.3 The light and power source shall be capable of being removed and replaced without causing damage to the lifejacket or immersion suit.

#### *Activation*

- 5.3 The light shall be easy to activate with wet, cold or gloved hands in adverse conditions with the minimum of preparation.

#### *Performance*

- 5.4.1 A lifejacket light shall not be damaged in stowage in an air temperature range of  $-30^{\circ}\text{C}$  to  $+65^{\circ}\text{C}$ .
- 5.4.2 It shall operate as prescribed in paragraphs 5.4.7 and 5.4.8 in a seawater temperature range of  $-1^{\circ}\text{C}$  to  $+30^{\circ}\text{C}$ . It shall also be capable of operating in fresh water.
- 5.4.3 It shall be capable of operation in a sea-way when attached to a lifejacket or immersion suit.
- 5.4.4 It shall be visible over as great a segment of the upper hemisphere as is practicable when attached to a lifejacket or immersion suit.
- 5.4.5 It shall be white in colour.
- 5.4.6 A flashing light shall flash at a rate of not less than 50 and not more than 70 flashes per minute and shall attain this rate within 5 minutes of activation.
- 5.4.7 A water activated light shall commence functioning within 2 minutes of immersion and have reached a luminous intensity of 0.75 candela within 5 minutes in salt water at temperatures of  $-1^{\circ}\text{C}$  and  $+30^{\circ}\text{C}$  and within 10 minutes in fresh water at ambient temperature.
- 5.4.8 A fixed light and a flashing light with a flash duration of not less than 50 flashes and not more than 70 flashes per minute shall have a luminous intensity of not less than 0.75 candela in all directions of the upper hemisphere.
- 5.4.9 A light shall have a source of energy capable of providing the luminous intensity, or effective luminous intensity, as appropriate, for a period of at least 8 hours.
- 5.4.10 The unit and the lifejacket or immersion suit attachment arrangements shall be capable of withstanding a jump into the water from a height of 4.5 metres without the unit being damaged or dislodged or causing injury to the wearer of the lifejacket or immersion suit.
- 5.4.11 The unit shall be capable of withstanding a drop of 2 metres onto a rigidly mounted steel plate or concrete surface.

## *Marking*

- 5.5.1 The unit shall be indelibly marked with –
- 5.5.1.1 the manufacturer's name or trade mark;
  - 5.5.1.2 the batch number or other means of identifying the unit; and
  - 5.5.1.3 clear and concise directions in English for activating the light supported by illustrations.
- 5.5.2 The unit or power source as appropriate, shall be marked indelibly with the date of manufacture and expiry of the power source.

## *Instructions and Information*

- 5.6.1 Instructions and information shall be in a form suitable for the training manual and, if appropriate, in the instructions for on-board maintenance referred to in Schedule 14. Instructions and information shall be in English in a clear and concise form and shall include –
- 5.6.1.1 the method or methods of attachment to lifejackets and immersion suits;
  - 5.6.1.2 the type of power source for the particular type of light;
  - 5.6.1.3 if the power source is replaceable, the method of replacement;
  - 5.6.1.4 the type of light source and whether replaceable;
  - 5.6.1.5 any maintenance requirements including the method and recommended frequency of checks of power source; and
  - 5.6.1.6 the operation of the light.

**Small Passenger Ship Regulations**  
regs 5, 6, 7, 8 and 9

**Other Ships Regulations**  
regs 42, 43, 44, 45, 46, 47, 48  
63, 64, 65, 66, 67, 68 and 69

## **PART 2 – INHERENTLY BUOYANT LIFEJACKETS** **(For persons weighing 32 kilogrammes or over)**

### *General*

1. Inherently buoyant lifejackets for persons weighing 32 kilogrammes or over shall comply with the requirements of Part 1 and the requirements in this Part.

### *Materials*

- 2.1 Buoyancy material shall be of good quality synthetic material, or kapok.
- 2.2 Cover material where used shall be of –
- 2.2.1 good quality synthetic material, or pre-shrunk cotton material free of admixture of sizing or other foreign matter; and
  - 2.2.2 a highly visible colour such as traffic yellow (BSEN 381, Ref 368) international orange (BSEN 381, Ref 592) or a colour of equivalent conspicuity.

- 2.3 Where a synthetic cover material is used and the seams are stitched, the thread shall be of synthetic material. Where cotton cover material is used the thread shall be of natural fibre or a combination of synthetic and natural fibre.
- 2.4 Fastening tapes shall not be less than 32 millimetres wide and have a breaking strength of not less than 1.4 kiloNewtons. Tapes of a synthetic material shall be capable of providing an equivalent degree of security when tied as that provided by cotton tapes.

*Instructions and Information*

3. Instructions and information shall be in a form suitable for the training manual referred to in Schedule 14. Instructions and information shall be in English in a clear and concise form and shall include how the lifejacket is to be donned and secured.

**Small Passenger Ship Regulations**  
regs 5, 6, 7, 8 and 9

**Other Ships Regulations**  
regs 42, 43, 44, 45, 46, 47, 48  
63, 64, 65, 66, 67, 68 and 69

**PART 3 – INHERENTLY BUOYANT LIFEJACKETS  
(For persons weighing less than 32 kilogrammes)**

*General*

1. Inherently buoyant lifejackets for persons weighing less than 32 kilogrammes shall comply with the requirements of Parts 1 and 2, except that –
- 1.1 donning assistance is permitted for small children;
- 1.2 it shall only be required to lift the mouth of an exhausted or unconscious wearer clear of the water a distance appropriate to the size of the intended wearer;
- 1.3 assistance may be given to board a survival craft, but wearer mobility shall not be significantly reduced; and
- 1.4 in addition to the markings required by paragraph 4.2 of Part 1 they shall be marked with a “child” symbol as shown in the “childs lifejacket” symbol in Section B of Schedule 16 and the height or weight range for which the lifejacket will meet the approval requirements.

**Small Passenger Ship Regulations**  
regs 5, 6, 7 8 and 9

**Other Ships Regulations**  
regs 42, 43, 44, 45, 46, 47, 48  
63, 64, 65, 66, 67, 68 and 69

**PART 4 – INFLATABLE LIFEJACKETS  
(for persons weighing 32 kilogrammes or over)**

*General*

1. Inflatable lifejackets for person weighing 32 kilogrammes or over shall comply with the requirements of Part 1 and the requirements in this Part.

*Construction*

- 2.1 An inflatable lifejacket shall be constructed with not less than two separate compartments and it shall inflate automatically on immersion. The automatic inflation system shall be so designed and protected that the risk of inadvertent inflation is reduced to a minimum. It shall be provided with a device to permit inflation by a single manual motion and shall be capable of being inflated by mouth.

- 2.2 In the event of loss of buoyancy in any one compartment the lifejacket shall be capable of complying with the requirements of paragraphs 2.1, 3.1 and 3.2 of Part 1.
- 2.3 The inflatable compartments shall be so located that when inflated they do not channel water into the wearer's face when in a sea-way.
- 2.4 An inflatable lifejacket shall comply with the requirements of paragraph 2.2 of Part 1 after inflation by means of the automatic mechanism.

#### ***Materials and Components***

- 3.1 Materials and components shall comply, as applicable, with the requirements of BS EN 394 and 396.
- 3.2 Materials used on the exterior of the buoyancy chambers shall be of a highly visible colour such as traffic yellow (BS EN 381, Ref 368), international orange (BS EN 381, Ref 592) or a colour of equivalent conspicuity.

#### ***Instructions and Information***

- 4. Instructions and information shall be in a suitable form for the training manual and, if appropriate, the instructions for on-board maintenance referred to in Schedule 14. Instructions and information shall be in English in a clear and concise form and shall include –
  - 4.1 a description of lifejacket and attachments;
  - 4.2 the method of donning;
  - 4.3 the method of operation;
  - 4.4 its packaging;
  - 4.5 any maintenance requirements;
  - 4.6 any servicing requirements;
  - 4.7 the type and charged weight of gas bottles; and
  - 4.8 the method of replacing gas bottles.

Small Passenger Ships Regulations  
regulations 7 and 8

### **PART 5 – INFLATABLE CIVIL AVIATION AUTHORITY LIFEJACKET**

Inflatable lifejackets which are suitable for persons weighing 32 kilogrammes or more, or less than 32 kilogrammes, which have been approved by the United Kingdom Civil Aviation Authority comply with this Schedule if they have been fitted with a ring or loop or similar device, having a minimum breaking strain of 1.8 kiloNewtons to facilitate rescue: provided that an approved light is not required.

Small Passenger Ships Regulations  
regulation 7 and 8

### **PART 6 – BUOYANCY AIDS**

Inherent buoyant lifejackets for persons weighing 32 kilogrammes or over, or under 32 kilogrammes shall comply with requirements of British Standard CEN 100 Standard and in addition shall be fitted with a ring or loop or similar device, having a minimum breaking strain of at least 1.8 kiloNewton to facilitate rescue.

## SCHEDULE 10

### REQUIREMENTS FOR IMMERSION SUITS, ANTI-EXPOSURE SUITS AND THERMAL PROTECTIVE AIDS

#### PART 1 – IMMERSION SUITS

##### *General*

1. Every lifejacket and its attachment required by Regulations shall comply with the requirements of Schedule 1 as is applicable to it.

##### *Construction*

- 1.1 An immersion suit shall be constructed with proper workmanship and waterproof materials.
- 1.2 The materials of the suit shall be rot-proof, corrosion resistant and not unduly affected by seawater, oil or fungal attack.
- 1.3 An immersion suit shall be of a highly visible colour to assist detection.
- 1.4 It shall be fitted with retro-reflective material to assist detection.
- 1.5 It shall be constructed to cover the whole body with the exception of the face. Hand covering shall be provided as an integral part of the suit or by means of permanently attached gloves.
- 1.6 It shall be provided with arrangements to minimise or reduce free air in the legs of the suit.
- 1.7 It shall be fitted with a non-metallic whistle not affected by water and humidity and firmly secured by a cord of suitable length, means of attaching a lifejacket light complying with Part 1 in Schedule 9 and, if the suit has buoyancy and is designed to be worn without a lifejacket, a ring or loop or similar device of adequate strength to facilitate rescue.
- 1.8 An immersion suit which also complies with the requirements of Parts 1 or 2 of Schedule 9 may be classified as a lifejacket.
- 1.9 An immersion suit shall be provided with a valise or container for stowage purposes.

##### *Performance*

- 2.1 An immersion suit shall not be damaged in stowage in the air temperature range of  $-30^{\circ}\text{C}$  to  $+65^{\circ}\text{C}$ .
- 2.2 It shall operate in a seawater temperature range of  $-1^{\circ}\text{C}$  to  $+30^{\circ}\text{C}$ .
- 2.3 It shall be resistant to deterioration where exposed to sunlight.
- 2.4 An immersion suit shall be capable of satisfactory operation in a sea-way.
- 2.5 An immersion suit shall permit the person wearing it (and a lifejacket if the immersion suit is to be worn in conjunction with a lifejacket) to –
  - 2.5.1 climb up and down a vertical ladder at least 5 metres in length;
  - 2.5.2 perform normal duties during abandonment;

- 2.5.3** jump from a height of not less than 4.5 metres into the water without damaging or dislodging the immersion suit, or being injured; and
- 2.5.4** swim a short distance through the water and board a survival craft.
- 2.6** The suit shall be capable of being unpacked and donned without assistance within 2 minutes, taking into account any associated clothing and a lifejacket if the immersion suit is to be worn in conjunction with a lifejacket.
- 2.7** It shall not sustain burning or continue melting after being totally enveloped in a fire for a period of 2 seconds.
- 2.8** Following a jump from a height of not less than 4.5 metres into water there shall be no undue ingress of water into the suit.
- 2.9** When the wearer is exposed to disturbed water conditions for a period of 20 minutes there shall be no undue ingress of water into the suit.
- 2.10** The person wearing it shall be able to don a lifejacket without assistance if the immersion suit is to be worn with a lifejacket over it.
- 2.11** If the material has no inherent insulation the suit when worn in conjunction with warm clothing (and a lifejacket if the immersion suit is to be worn with a lifejacket) the suit shall provide sufficient thermal protection to ensure that the wearer's body core temperature does not fall more than 2°C, –
- 2.11.1** when it is worn for a period of 1 hour in calm circulating water at a temperature of 5°C taking into account any water ingress following a jump into the water from a height of 4.5 metres; and
- 2.11.2** a 20 minute period in disturbed water conditions.
- 2.12** If the material has inherent insulation either on its own or when worn with a lifejacket (if the immersion suit is to be worn in conjunction with a lifejacket) the suit shall provide sufficient thermal insulation to ensure that the wearer's body core temperature does not fall more than 2°C, –
- 2.12.1** after a period of 6 hours immersion in calm circulating water at a temperature of between 0°C and 2°C, taking into account any water ingress following a jump into the water from a height of 4.5 metres; and
- 2.12.2** a 20 minute period in disturbed water conditions.
- 2.13** After being immersed in water at 5°C for a period of 1 hour the wearer of the immersion suit shall be able to pick up a pencil and write with hands covered.
- 2.14** A person in fresh water wearing an immersion suit which complies with the requirements of Parts 1 or 2 of Schedule 9 or an immersion suit with a lifejacket shall –
- 2.14.1** be able to turn from a face-down to a face-up position in not more than 5 seconds;
- 2.14.2** float in a stable face-up position with the mouth not less than 120 millimetres clear of the water.

### *Marking*

3. An immersion suit and the valise or container in which it is stowed shall be marked indelibly with the –
  - 3.1 manufacturer's name or trade mark;
  - 3.2 date of manufacture;
  - 3.3 size range for which it is designed;
  - 3.4 serial number; and
  - 3.5 instruction that it must be worn in conjunction with warm clothing if the suit is made of material which has no inherent insulation.

### *Instructions and information*

4. Instructions and information shall be in a suitable form for the training manual referred to in Part 1 of Schedule 14 and, if appropriate, for on-board maintenance referred to in Part 2 of that Schedule. Instructions and information shall be in English in a clear and concise form and shall include –
  - 4.1 a description of the immersion suit and attachments;
  - 4.2 on donning;
  - 4.3 on the operation of any auxiliary buoyancy;
  - 4.4 on the method of stowage;
  - 4.5 on any servicing and maintenance requirements;
  - 4.6 on cleaning; and
  - 4.7 its use.

## **PART 2 – ANTI-EXPOSURE SUITS**

### *Construction*

- 1.1 The anti-exposure suit shall comply with the requirements of Part 1 paragraphs 1, 2, 3 and 4 as applicable and with the requirements of this Part.
- 1.2 The anti-exposure suit shall be constructed with waterproof materials such that it –
  - 1.2.1 provides inherent buoyancy of at least 70 Newtons;
  - 1.2.2 is made of material which reduces the risk of heat stress during rescue and evacuation operations;
  - 1.2.3 covers the whole body with the exception of the head and hands; gloves and a hood shall be provided in such a manner as to remain available for use with the anti-exposure suits;
  - 1.2.4 can be unpacked and donned without assistance within 2 minutes;
  - 1.2.5 does not sustain burning or continue melting after being totally enveloped in a fire for a period of 2 seconds;

- 1.2.6 is equipped with a pocket for a portable VHF telephone; and
- 1.2.7 has a lateral field of vision of at least 120 degrees.
- 2.1 An anti-exposure suit which also complies with the requirements of Part 1 and 2, Schedule 9 may be classified as a lifejacket.
- 2.2 An anti-exposure suit shall permit the person wearing it, to –
  - 2.2.1 climb up and down a vertical ladder of at least 5 metres in length;
  - 2.2.2 jump from a height of not less than 4.5 metres into the water with feet first, without damaging or dislodging the suit, or being injured;
  - 2.2.3 swim through the water at least 25 metres and board a survival craft;
  - 2.2.4 don a lifejacket without assistance; and
  - 2.2.5 perform all duties associated with abandonment, assist others and operate a rescue boat.
- 2.3 An anti-exposure suit shall be fitted with a lifejacket light and a whistle.
- 2.4 An anti-exposure suit shall –
  - 2.4.1 if made of material which has no inherent insulation, be marked with instructions that it must be worn in conjunction with warm clothing; and
  - 2.4.2 be so constructed, that when worn as marked, the suit continues to provide sufficient thermal protection following one jump into the water which totally submerges the wearer and shall ensure that when it is worn in calm circulating water at a temperature of 5 degrees C, the wearer's body core temperature does not fall at a rate of more than 1.5 degrees C per hour, after the first 30 minutes.
- 2.5 A person in fresh water wearing an anti-exposure suit shall be able to turn from a face-down to a face-up position in not more than 5 seconds and shall be stable face-up. The suit shall have no tendency to turn the wearer face-down in moderate sea conditions.

**Other Ships Regulations**  
 regs 7, 8, 10, 11, 63, 64, 65, 66, 68 and 69  
 Parts 2, 7 and 8 Schedule 2  
 Parts 2 and 3 of Schedule 3  
 Part 6 of Schedule 4

### PART 3 – THERMAL PROTECTIVE AIDS

#### *Construction*

- 1.1 A thermal protective aid shall be constructed with proper workmanship and materials.
- 1.2 The materials of a thermal protective aid shall be rot-proof, corrosion resistant, and not unduly affected by seawater, oil or fungal attack.
- 1.3 A thermal protective aid shall be made of waterproof material having a thermal conductivity of not more than  $7800W/(m^2K)$  and shall be so constructed that, it will reduce both the convective and evaporative heat loss from the wearer's body.



- 1.4 It shall be so constructed as to cover the whole body of a person wearing a lifejacket with the exception of the face. Hands shall also be covered unless permanently attached gloves are provided.
- 1.5 It shall be of a highly visible colour to assist detection.
- 1.6 It shall be protected by waterproof packaging which can be opened with wet or cold hands.

#### *Performance*

- 2.1 A thermal protective aid shall not be damaged in stowage in the air temperature range  $-30^{\circ}\text{C}$  to  $+65^{\circ}\text{C}$ .
- 2.2 It shall function properly in the air temperature range  $-30^{\circ}\text{C}$  to  $+20^{\circ}\text{C}$
- 2.3 It shall function in the seawater temperature range  $-1^{\circ}\text{C}$  to  $+30^{\circ}\text{C}$  if designed to be worn in a sea-way.
- 2.4 It shall be capable of being unpacked and easily donned without assistance in a survival craft or rescue boat.
- 2.5 It shall permit the wearer to remove it in the water in not more than 2 minutes, if it impairs ability to swim.

#### *Marking*

3. The thermal protective aid packaging shall be marked with –
  - 3.1 the manufacturer's name or trade mark; and
  - 3.2 instructions for use.

#### *Instructions and Information*

4. Instructions and information shall be in a form suitable for the training manual referred to in Part 1 of Schedule 14. Instructions and information shall be in English in a clear and concise form and include –
  - 4.1 stowage in lifeboats and liferafts;
  - 4.2 unpacking;
  - 4.3 donning in a survival craft;
  - 4.4 its removal from the wearer in the water (if applicable);
  - 4.5 its purpose, and when it should be used;
  - 4.6 whether or not ability to swim is impaired when wearing the aid; and
  - 4.7 on how it is to be checked and inspected.

## SCHEDULE 11

### GENERAL EMERGENCY ALARM SYSTEMS AND PUBLIC ADDRESS SYSTEMS

#### PART 1 – GENERAL EMERGENCY ALARM SYSTEMS

1. The general emergency alarm system shall be capable of sounding the general emergency alarm signal consisting of seven or more short blasts followed by one long blast on the ship's whistle or siren and additionally, in the case of ships of Classes I, II and II(A), and of Classes VII, VII(T), VIII, VIII(T) and IX of 45.7 metres in length or above on an electrically operated bell or klaxon or other equivalent warning system. This additional system shall be powered from the ship's main supply and from the emergency source of electrical power required by the Merchant Shipping (Passenger Ship Construction) Regulations 1996 or the Merchant Shipping (Cargo Ship Construction) Regulations 1996 as applicable.
2. The system shall be capable of operation from the navigating bridge and, except for the ship's whistle, also from other strategic points. The system shall be audible throughout all the accommodation and normal crew working spaces.
3. The system shall also be audible on all open decks and its sound level shall comply with paragraphs 5 and 6. The alarm shall continue to sound until it is manually turned off or is temporarily interrupted by a message on the public address system.
4. Entertainment systems shall be turned off automatically when the general emergency alarm system is activated.
5. The minimum sound pressure levels for the emergency alarm tone in interior and exterior spaces shall be 80 dB (A) and at least 10 dB (A) above ambient noise levels existing during normal equipment operation with the ship underway in moderate weather. In cabins without a loudspeaker installation, an electronic alarm transducer shall be installed, e.g. a buzzer or similar.
6. The sound pressure levels at the sleeping position in cabins and in cabin bathrooms shall be at least 75 dB (A) and at least 10 dB (A) above ambient noise levels.

Other Ships Regulations  
regs 7, 8 and 9

#### PART 2 – PUBLIC ADDRESS SYSTEMS

1. The public address system shall be one complete system consisting of a loudspeaker installation which enables simultaneous broadcast of messages from the navigation bridge, and at least one other location on board for use when the navigation bridge has been rendered unavailable due to the emergency, to all spaces where crew members or passengers, or both are normally present and to assembly stations (i.e. muster stations). The controls of the system on the navigation bridge shall be capable of interrupting any broadcast on the system from any other location on board. It shall not require any action by the addressee. It shall also be possible to address crew accommodation and work spaces separately from passenger spaces.
2. In addition to any function provided for routine use aboard the ship, the system shall have an emergency function control at each control station which –
  - 2.1 is clearly indicated as the emergency function;
  - 2.2 is protected against unauthorized use;

- 2.3 automatically overrides any other input system or programme; and
  - 2.4 automatically overrides all volume controls and on/off controls so that the required volume for the emergency mode is achieved in all spaces.
3. The system shall be installed with regard to acoustically marginal conditions, so that emergency announcements are clearly audible above ambient noise in all spaces. With the ship underway in normal conditions, the minimum sound pressure levels for broadcasting emergency announcements shall be –
- 3.1 in interior spaces 75 dB (A) and at least 20 dB(A) above the speech interference level; and
  - 3.2 in exterior spaces 80 dB (A) and at least 15 dB (A) above the speech interference level.
4. The system shall be arranged to prevent feedback or other interference.
5. The system shall be arranged to minimize the effect of a single failure, e.g. by the use of multiple amplifiers with segregated cable routes to public rooms, alleyways, stairways, and control stations. The public address systems shall have at least two loops of fire resistant cable which shall be sufficiently separated throughout their length and have two separate and independent amplifiers.
6. Each loudspeaker shall be individually protected against short circuits.
7. The public address system shall be arranged to operate on both the main source of electrical power and the emergency source of electrical power.

## SCHEDULE 12

### BUOYANT APPARATUS

#### *General*

1. Buoyant apparatus shall –
  - 1.1 be constructed with proper workmanship and materials;
  - 1.2 retain the shape and properties when exposed to the weather on board ship and when in the water. They shall be constructed so as not to require adjustment prior to use; and
  - 1.3 be corrosion-resistant and not affected by sea water, oil or oil products.

#### *Construction*

- 2.1 Buoyant apparatus shall be capable of withstanding a minimum drop into the water from a height of 10 metres. If they are to be stowed in a vessel at a height of more than 10 metres above the waterline in the lightest seagoing condition, they shall be of a type which has been satisfactorily drop-tested from at least that height.
- 2.2 Buoyant apparatus shall be effective and stable when floating either way up. They shall be capable of supporting a weight of iron, suspended in fresh water from the grab lines, of 22.5 kilogrammes per metre of length along any edge (subject to a minimum of 29 kilogrammes), without immersing any part of their upper surfaces.
- 2.3 The air cases or other equivalent provision for buoyancy shall be placed as near as possible to the sides of the apparatus. Buoyancy is not to be dependant upon inflation and any material providing buoyancy shall not be adversely affected by oil or oil products.
- 2.4 A buoyant apparatus shall not exceed 185 kilogrammes in weight unless suitable means are provided to enable it to be launched without lifting by hand. If the weight of the apparatus exceeds 135 kilogrammes suitable handles or rungs are to be fitted for lifting by hand.
- 2.5 The number of persons which a buoyant apparatus shall be considered capable of supporting shall be equal to the lesser of –
  - 2.5.1 the greatest whole number obtained by dividing by 14.5 the number of kilogrammes of iron which the apparatus is capable of supporting from its grab lines in fresh water; or
  - 2.5.2 the greatest whole number obtained by dividing the perimeter in metres by 0.3.

#### *Fittings*

- 3.1 Grab Lines
  - 3.1.1 Buoyant grablines shall be securely fitted all around the apparatus so as to provide an equal number of loops, the total number corresponding to the number of persons the apparatus is capable of supporting.
  - 3.1.2 Each loop shall have a depth of not less than 150 millimetres and not more than 200 millimetres. On apparatus exceeding 300 millimetres in overall depth two rows of grablines shall be fitted, one having its points of attachment below the top of the air

cases and the other above the bottom of the air cases and as close to the sides of the air cases as practical. On apparatus of 300 millimetres or less in overall depth, one row of grab lines is to be attached along the line at mid-depth.

3.1.3 Grab lines shall be of buoyant rope of not less than 14 millimetres in diameter. The ropes may be passed through holes in the framing, interlaced to prevent movement; or attached by means of wrought iron or steel fastenings. Whichever method is used the attachment is to be of sufficient strength to permit the apparatus to be lifted by the grab lines.

3.2 Each buoyant apparatus shall be fitted with an efficient painter of length at least equal to the height from its stowed position to the lightest sea going condition plus 5 metres.

3.3 Retro-reflective material is to be fitted on all surfaces of the buoyant apparatus.

#### *Marking*

4. Each apparatus shall be marked with the –

4.1 maker's name or trademark;

4.2 serial number; and

4.3 maximum permitted height of stowage above waterline.

**SCHEDULE 13****SURVIVAL CRAFT EQUIPMENT AND RATIONS****PART 1 – FIRST AID OUTFITS**

- 1.1** The first aid outfit provided in every lifeboat, rescue boat, inflated boat or liferaft shall comply with the following requirements –
- 1.1.1** it shall be packed in a durable, damp-proof and effectively sealed container, capable of being closed tightly after use;
- 1.1.2** the container shall be protected; until opened for use, with an outer waterproof seal;
- 1.1.3** the container shall bear on its outside an itemised list of its contents, and their date of expiry;
- 1.1.4** it must comply with the implemented UK requirements of Council Directive 92/29/EEC which sets out minimum standards for ships' medical stores by introducing the Merchant Shipping and Fishing Vessel (Medical Stores) Regulations 1995, as amended by the Merchant Shipping and Fishing Vessel (Medical Stores) Amendment Regulations 1996. Merchant Shipping Notice MSN 1707 (M+F) lists the requirements for Category C vessels which lifeboats and life-rafts are required to carry and is shown in Table 1; and
- 1.1.5** drug supplies should be replenished wherever possible at the same strengths as specified in the British Pharmacopoeia. If drugs are obtained elsewhere, e.g in the USA, they may be of different strength, and this must be taken into account when administering them.

**TABLE 1****CATEGORY C  
MEDICAL SUPPLIES**

The numbering refers to the number allocated to the medicine or equipment in the Directive

<b>Ref no</b>	<b>Statutory Treatment Requirements</b>	<b>Recommended Medicine and Dosage Strength representing best practice</b>	<b>Recommended Quality for 10 workers or for a lifeboat or liferaft</b>
1	<b>Cardio vascular</b>		
(b)	Anti-angina preparations	Glyceryl Trinitrate Spray 400 micrograms/metered 200 dose aerosol or transdermal patches 5mg x 2	1 unit
(d)	Anti-haemorrhagics (including uterotonics if there are women with potential for child bearing working on board)	i) Phytomenadione (Vitamin K1) 10mg in 1ml ampoule	1

Ref no	Statutory Treatment Requirements	Recommended Medicine and Dosage Strength representing best practice	Recommended Quality for 10 workers or for a lifeboat or liferaft
		ii) Ergometrine Maleate 500mg inj. Oxytocin 5 units in 1ml ampoule	1
2	<b>Gastro intestinal system</b>		
(b)	Anti-emetics	Hyoscine hydrobromide 0.3mg tabs.	60
(d)	Anti-diarrhoeals	Codeine Phosphate 30mg tablets	20
3	<b>Analgesics and Anti-spasmodics</b>		
(a)	Analgesics	i) Paracetamol ii) Use 2(d)	50 Use 2(d)
4	<b>Nervous system</b>		
(c)	Seasickness remedies	Use 2(d)	Use 2(d)
9	<b>Medicines for External Use</b>		
(a)	Skin medicine		
	- Antiseptic solutions	100ml solution or pre-impregnated wipes containing 0.015% w/v chlorhexidine and 0.15% w/v cetrimide	1 bottle or 1 pack wipes
	- Burn preparations	Cetrimide Cream 50g tube	1

#### MEDICAL EQUIPMENT

Ref	Statutory Treatment Requirements	Recommended Specification	Quantity
1	<b>Resuscitation Equipment</b>		
	Mask for mouth to-mouth resuscitation	Laerdal Pocket Mask (or similar)	1
2	<b>Dressing and suturing equipment</b>		
	Adhesive elastic bandage	Adhesive Elastic Bandage 7.5cm x 4m	1
	Disposable polyethylene gloves	large size	5prs
	Adhesive dressings	assorted, sterile	20
	Sterile compression bandages	(1) No. 13 Standard dressings (1) No. 14 Standard dressings (1) No. 15 Standard dressings	6 2 2
	Adhesive sutures or zinc oxide bandages	75mm adhesive suture strips	6
	Sterile Gauze Compresses	Packet containing 5 sterile gauze pads size 7.5cms x 7.5cms	1

Ref	Statutory Treatment Requirements	Recommended Specification	Quantity
		<b>Recommended Additional Item</b>	
		Scissors stainless steel/ or sterile disposable size	1 pr
		Calico triangular bandages about 90cm x 127cm	4
		medium safety pins, rustless	6
		sterile paraffin gauze dressings	10
		plastics burn bags	1

Schedule 2 Part 2

Schedule 4 Part 6

## PART 2 – FOOD RATIONS

1. The ration for each one or two persons shall be enclosed in substantial packaging of suitable efficiently sealed oxygen impermeable and moisture-proof materials. A ration intended for a lifeboat shall additionally be protected by durable water-resistant packaging.
2. The outer packaging or wrapping shall be marked with the manufacturer's name or trade mark, the weight, calorific value and description of the contents and the dates of manufacture and renewal. A description of the contents shall be marked on the inner packaging. It shall be possible to open the wrapping and packaging with wet or cold hands.
3. Recommended quantities of ration and fresh water to be consumed daily shall be marked in English on the packaging or on a water resistant instruction sheet included in the ration.
4. The ration for each person shall have a calorific value of not less than 10,000 kilojoules.
5. The composition of the ration –
  - 5.1 shall include at least 300 grammes of carbohydrate in the form of bland barley sugar sweets, glucose tablets or as part of a food tablet. The ration shall not include protein at a greater rate than 3 grammes per 10 grammes of carbohydrate or fat at a greater rate than 4 grammes per 10 grammes of carbohydrate; and
  - 5.2 shall have a salt content as low as possible which must not exceed 1 gramme NaCl. If the ration includes an approved anti-oxidant it shall be included at the rate of 0.02 per cent by weight of the fat component of the ration.
6. The moisture content of any barley sugar or food tablets in the ration shall not exceed 3 per cent and 7 per cent by weight respectively. The moisture content of a glucose tablet shall be as low as possible and compatible with the recommended operational shelf-life.
7. The ration shall be palatable to a survivor limited to a fresh water intake of 0.5 litres per day.
8. The ration shall remain palatable throughout its recommended shelf-life under the climatic conditions normally encountered.
9. The ration shall be readily divisible into at least 3 one-day portions for one person.



## PART 3 – FRESH WATER

### *General*

- 1.1 The water shall comply with the UK Laboratory of the Government Chemist test requirements or the equivalent standards of another State of the European Union to confirm that the water is microbiologically and chemically suitable for drinking and conforms to World Health Organisation standards.
- 1.2 Processing, packaging and sterilisation arrangements shall be carried out under hygienic conditions and quality assurance inspection acceptable to the Maritime and Coastguard Agency or the equivalent authority of another member State of the European Union.
- 1.3 The water shall remain palatable in its storage containers in the survival craft in a temperature range of  $-30^{\circ}\text{C}$  to  $+65^{\circ}\text{C}$ .

### *Water Containers*

#### *Sachets*

- 2.1.1 The water shall be packed in efficiently sealed sachets which are impermeable, moisture proof and have an effective vapour barrier.
- 2.1.2 The sachets shall have a cut above the top seal to facilitate easy opening with wet or cold hands.
- 2.1.3 Individual sachets shall contain not less than 50 and not more than 150 millilitres of water.
- 2.1.4 Water filled sachets shall be capable of withstanding a compressive load test of 5 kiloNewtons without bursting.
- 2.1.5 Except as provided for in paragraph 2.1.6 water sachets packed in a liferaft emergency pack shall not be affected by any of the prototype tests carried out on a liferaft.
- 2.1.6 When included in the emergency pack of an operationally packed liferaft no more than 2 per cent of the water sachets shall be damaged after the appropriate drop test.
- 2.1.7 The recommended shelf life of the water sachets shall be at least 3 years.
- 2.1.8 The outer packaging shall be marked with the following information the –
  - 2.1.8.1 manufacturer's name or trade mark;
  - 2.1.8.2 contents capacity;
  - 2.1.8.3 lot number;
  - 2.1.8.4 date of manufacture; and
  - 2.1.8.5 a recommended daily consumption per person.

## *Cans*

- 2.2.1 Cans in which drinking water is supplied shall be hermetically sealed with a vacuum of not less than 510 millimetres of mercury.
- 2.2.2 They shall be constructed of tinplate with minimum thickness 0.30 millimetres and a tin content conforming to the relevant part of section 10 of British Standard 113.
- 2.2.3 The cans shall be constructed with a double seam and properly balanced interlocking hooks. They shall be left plain internally but coated externally with a machine applied golden lacquer and then stoved.
- 2.2.4 The capacity of the can shall not be greater than 500 millilitres.
- 2.2.5 After filling the seams shall be inspected and any exposed areas shall be suitably lacquered.
- 2.2.6 A click test to confirm the vacuum shall be carried out on each can 7 days after filling.
- 2.2.7 The cans shall be free from dents or any signs of corrosion.
- 2.2.8 The cans shall not be affected by any of the prototype tests carried out on a liferaft.
- 2.2.9 The cans shall be clearly marked on the outside with the –
  - 2.2.9.1 manufacturer's name or trade mark;
  - 2.2.9.2 words "drinking water" and the capacity of the can in millilitres;
  - 2.2.9.3 lot or batch number;
  - 2.2.9.4 date of manufacture; and
  - 2.2.9.5 a recommended daily consumption per person.

## *Bottles*

- 2.3.1 Bottles in which drinking water is supplied shall be manufactured from a material which will not contaminate or effect the taste of the water.
- 2.3.2 They shall not be affected by any of the prototype tests carried out on a liferaft.
- 2.3.3 The material from which the bottle is made shall be opaque.
- 2.3.4 The capacity of the bottle shall not be greater than 500 millilitres.
- 2.3.5 The bottle shall be capable of being opened by a survivor with cold hands.
- 2.3.6 The minimum recommended shelf life of the water bottle and its contents shall be at least 3 years.
- 2.3.7 The bottle filling cap shall be fitted with a watertight seal, and have positive locking arrangements which will not be loosened by vibration. After the bottle has been filled and the cap fitted it shall be provided with an outer continuous seal which must not be broken until the water is used or has become time expired.

- 2.3.8 The bottle shall be marked on the outside with the –
- 2.3.8.1 manufacturer's name or trade mark;
  - 2.3.8.2 date of filling;
  - 2.3.8.3 date of expiry;
  - 2.3.8.4 words "drinking water" and the capacity of the bottle in millilitres;
  - 2.3.8.5 recommended daily consumption per person; and
  - 2.3.8.6 lot or batch number.

*Water tanks*

- 2.4.1 Tanks fitted for fresh water in a survival craft may be of metal or a plastic material acceptable to the Maritime and Coastguard Agency or the equivalent competent authority or of another member State of the European Union.
- 2.4.2 Each tank is to be filled and emptied to ensure cleanliness and to check for watertightness.
- 2.4.3 The tank shall be strong enough to withstand a head of water of at least 1.5 metres.
- 2.4.4 Where necessary the inside of the tank shall be suitably coated to prevent contamination or unpleasant taste.
- 2.4.5 Tanks which are not portable shall be fitted with drain plugs constructed of non-corrosive material.
- 2.4.6 Filling plugs and aperture covers shall be of non-ferrous materials, neatly fitted and made properly watertight to prevent the entry of contaminants.
- 2.4.7 Tanks shall be sited well clear of any propelling machinery.
- 2.4.8 At least one rustproof dipper with a lanyard shall be provided for each tank.
- 2.4.9 The inside of tanks constructed with glass reinforced plastic must be smooth and sealed with a gel coat.
- 2.4.10 Tanks made out of glass reinforced plastic shall be opaque.
- 2.4.11 The tank shall be clearly marked on the outside with the contents and its capacity in litres.

## PART 4 – SEA ANCHORS

1. A sea anchor shall be conical in shape and have the following dimensions –

CRAFT	SEA ANCHOR		Minimum Sloping Length of shroud Lines (mm)
	Minimum Mouth Diameter (mm)	Minimum Sloping Length (mm)	
Liferafts up to 10 person capacity	400	600	600
Liferafts 11 person capacity up to 25 person capacity and inflated boats	500	670	670
Liferafts over 25 person capacity, lifeboats and rescue boats up to 6 m in length	600	780	780
Lifeboats and rescue boats over 6 m in length and up to 9 m in length	700	920	920
Lifeboats over 9 m in length	800	1050	1050

2. The sea anchor material shall be porous, slightly stiff and shall allow a water penetration of between 10 and 12 cubic centimetres per second per square centimetre at a pressure of 550Pa (roughly equivalent to a speed through water of 2 knots).
3. The painter line used to secure the sea anchor to a liferaft or boat shall –
- 3.1 be inherently rot proof and of braided construction; and
  - 3.2 be 30 metres long; not less than 8 mm. in diameter and have a breaking load including attachments and knots of not less than –
    - 3.2.1 7.5 kN for liferafts up to 10 person capacity;
    - 3.2.2 10.0 kN for liferafts of 11 person to 25 person capacity; and
    - 3.2.3 10.0 kN for all other sea anchors or have a factor of safety of 3:1 based on a tow test at 6 knots whichever is the greater.
4. The shroud lines shall be designed to restrict the sea anchor from tumbling through itself.
5. The sea anchor shall be stable when towed through the water at speeds up to 6 knots.
6. The sea anchor mouth shall open immediately on deployment.

## SCHEDULE 14

### TRAINING MANUALS AND INSTRUCTIONS FOR ON-BOARD MAINTENANCE

#### PART 1 – TRAINING MANUALS

1. Training manuals shall contain instructions and information on the life-saving appliances provided in the ship. It shall also contain information on the best methods of survival. The material in the manual shall be in easily understood terms and illustrated where appropriate.
2. Training manuals may comprise one or more volumes and information may be provided in the form of audio-visual aids as an alternative to printed material.
3. Depending on the life-saving appliances provided in the ship, the following shall be explained in detail –
  - 3.1 donning of lifejackets, immersion suits and anti-exposure suits, as appropriate;
  - 3.2 muster at the assigned stations;
  - 3.3 boarding, launching, and clearing the survival craft, rescue boats, fast rescue boats, free-fall boats and inflated boats;
  - 3.4 method of launching from within the survival craft;
  - 3.5 release from launching appliances;
  - 3.6 methods and use of devices for protection in launching areas;
  - 3.7 illumination in launching areas;
  - 3.8 use of all survival equipment;
  - 3.9 use of all detection equipment;
  - 3.10 with the assistance of illustrations, the use of radio life-saving appliances;
  - 3.11 use of sea anchors;
  - 3.12 use of engine and accessories;
  - 3.13 recovery of the survival craft, rescue boats, fast rescue boats, free-fall boats and inflated boats including stowage and securing;
  - 3.14 hazards of exposure and the need for warm clothing;
  - 3.15 best use of the survival craft facilities in order to survive;
  - 3.16 methods of retrieval, including the use of helicopter rescue gear (slings, baskets, stretchers), breeches-buoy and shore life-saving apparatus and ship's line-throwing apparatus;
  - 3.17 all other functions contained in the muster list and emergency instructions;

- 3.18 instructions for emergency repair of the life-saving appliances;
- 3.19 means of rescue arrangements;
- 3.20 marine evacuation systems; and
- 3.21 helicopter landing and pick-up area operations.

**Other Ships Regulations**  
**regs 36 and 84**

## **PART 2 – INSTRUCTIONS FOR ON-BOARD MAINTENANCE**

1. Instructions for on-board maintenance of life-saving appliances shall be in easily understood terms and illustrated wherever possible.
2. The instructions shall include, where appropriate, the following for each appliance –
  - 2.1 a checklist for use when carrying out the inspections required by the Regulations;
  - 2.2 maintenance and repair instructions;
  - 2.3 a schedule of periodic maintenance;
  - 2.4 a diagram of lubrication points with the recommended lubricants;
  - 2.5 a list of replaceable parts;
  - 2.6 a list of sources of spare parts; and
  - 2.7 a record of inspection and maintenance.

## SCHEDULE 15

### CARRIAGE OF TWO-WAY VHF RADIOTELEPHONE SETS – EXEMPTING CONDITIONS

1. The conditions referred to in regulation 7(5)(b), 8(11)(b), 10(12)(b), 11(5)(b), 20(8)(b), 42(6)(b), 43(8)(b), 44(9)(b), 45(11)(b) and 47(3)(b) of the Other Ships Regulations under which ships may be exempted from the carriage of two-way VHF radiotelephone sets complying with performance standards contained in IMO Resolution A762(18) are given below.
  - 1.1 In the case of a passenger ship or a cargo ship of 500 tons or over, at least three and in the case of a cargo ship under 500 tons, at least two portable or VHF radiotelephone sets for use in survival craft shall be provided.
  - 1.2 The radiotelephone sets shall –
    - 1.2.1 be waterproofed;
    - 1.2.2 be capable of operating on radio frequency 156.8 MHz (VHF channel 16) and on at least one other channel;
    - 1.2.3 have the selection of 156.8 MHz (VHF Channel 16) correctly and clearly marked on the channel selector switch;
    - 1.2.4 in respect of United Kingdom ships, be of a type approved by the Department of Trade and Industry; or the equivalent competent authority of another member State of the European Union;
    - 1.2.5 have been provided on board ship prior to **1st February 1992**; and
    - 1.2.6 if replacement of a radio telephone becomes necessary, be replaced with approved equipment complying with IMO performance standards.
  - 1.3 Where secondary batteries are used in the radiotelephone sets, suitable arrangements shall be made to ensure the availability of fully charged sets at all times.

## SCHEDULE 16

### SYMBOLS RELATING TO LIFE-SAVING APPLIANCES AND ARRANGEMENTS

1. The Merchant Shipping (Life-Saving Appliances) Regulations 1999 require ships (other than fishing vessels) carrying survival craft to be provided with posters or signs on or in the vicinity of these craft and their launching controls. The posters and signs are to illustrate the purposes of the controls and the procedures for operating the appliance and to give relevant instructions or warnings. They must be capable of being seen under emergency lighting conditions where that is provided.
2. The symbols have been approved by the Maritime Safety Committee of the International Maritime Organization and the symbols used in the posters and signs referred to in paragraph 1 above must conform to the design and colour (white on a blue background) prescribed in Section A. The size of the symbol must be appropriate to the particular purpose for which it is being used; but where the diameter of the symbol is 60 millimetres or greater, it should be one of the preferred dimensions given in Amendment No. 1 to BS 5378 (a):Part 2: 1980.
3. The symbols are suitable for use on posters and signs at survival craft locations and for display inside survival craft adjacent to the relevant control or function to which they refer. Most of the symbols relate to totally enclosed lifeboats but there are some which can be used for conventional open lifeboats and davit-launched liferafts. In addition, symbols in the appropriate sequence can be displayed at the coxswain's position in a totally enclosed lifeboat as a reminder of the sequence of actions required to launch the lifeboat.
4. An additional set of symbols has also been approved by the Maritime Safety Committee and they appear in Section B. These symbols are intended to indicate the location of emergency equipment, and muster and embarkation stations. These symbols are not called for by the Regulations but many of them can be used with advantage on passenger ships. In particular, the symbol for a muster station (number 21) and the symbol indicating the direction to a muster/assembly station (number 23) could be used on passenger ships where such signs are required and on other passenger ships where the provision of such signs is appropriate.
5. Where symbols are used to indicate direction, or the stowage position of life-saving equipment, it is recommended that they conform in design and colour (white on a green background) with the relevant symbols in Section B and that the size of the signs is one of the preferred sizes in the British Standard referred to in paragraph 2

---

(a) BS 5378 - Safety signs and colours



SECTION - A



1. FASTEN SEAT BELT



2. SECURE HATCHES



3. START ENGINE

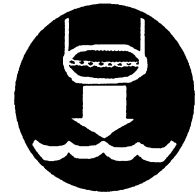

4.1 LOWER LIFEBOAT TO WATER



4.2 LOWER LIFERAFT TO WATER



4.3 LOWER RESCUE BOAT TO WATER



5. RELEASE FALLS

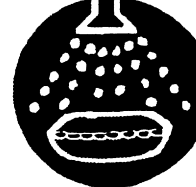

6. START WATER-SPRAY



7. START AIR SUPPLY



8. RELEASE GRIPS

SECTION - B

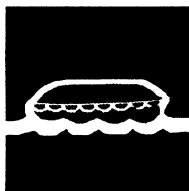

1. LIFEBOAT



2. RESCUE BOAT

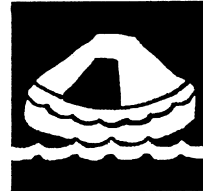

3. LIFERAFT



4. DAVIT-LAUNCHED LIFERAFT

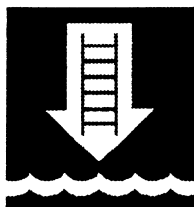

5. EMBANKMENT LADDER

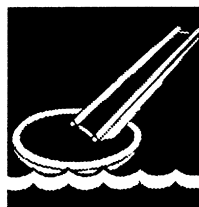

5. EVACUATION SLIDE

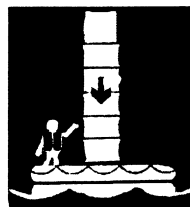

5. EVACUATION CHUTE



5. LIFEBOUY



9. LIFEBOUY WITH LINE



10. LIFEBOUY WITH LIGHTS



11. LIFEBOUY WITH LIGHT AND SMOKE



12. LIFEJACKET



12. CHILDS LIFEJACKET



13. IMMERSION SUIT PORTABLE RADIO



14. SURVIVAL CRAFT



15. EPIRB



17. RADAR TRANSPONDER



18. SURVIVAL CRAFT PYROTECHNIC DISTRESS SIGNALS



19. ROCKET PARACHUTE FLARES



20. LINE-THROWING APPLIANCE



21. MUSTER STATION



22. EMBARKATION LADDER

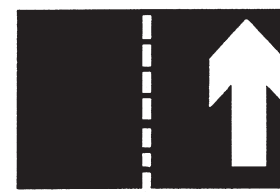

19. DIRECTION INDICATOR

MSPP2  
Maritime and Coastguard Agency  
Spring Place  
105 Commercial Road  
Southampton SO15 1EG

Tel 01703 329184  
Fax 01703 329204

April 1999

MS 10/19/16

© Crown Copyright 1999



An executive agency of the Department of the  
Environment, Transport and the Regions