

Multi Channel Pressure
Sensor Controller



Operation Manual

PSE200 Series



SMC Corporation

URL <http://www.smcworld.com>

Thank you for purchasing the SMC PSE200 Series Multi channel Pressure Sensor Controller. Please read this manual carefully before operating this controller and understand the controller, its capabilities and limitations.

Please keep this manual handy for future reference.

OPERATOR

- This operation manual has been written for those who have knowledge of machinery and apparatus that use pneumatic equipment and have full knowledge of assembly, operation and maintenance of such equipment.
- Please read this operation manual carefully and understand it before assembling, operating or providing maintenance service to the controller.

CONTENTS

SAFETY	2
Model Indication Method	5
Name and Functions of Individual Parts	6
Installation	8
Example of Internal Circuit and Wiring	11
Setting	13
Pressure setting mode	17
Special setting	21
Other Functions	26
Unit Label	29
Appended Table	30
Specification	31
Outline with Dimensions	33

SAFETY

The Pressure Sensor Controller and this manual contain essential information for the protection of users and others from possible injury and property damage and to ensure correct handling. Please check that you fully understand the definition of the following messages (signs) before going on to read the text, and always follow the instructions. Please read the operation manuals of related apparatus and understand it before operating the controller.

IMPORTANT MESSAGES

Read this manual and follow its instructions. Signal words such as WARNING and NOTE will be followed by important safety information that must be carefully reviewed.

⚠WARNING

Indicates a potentially hazardous situation that could result in death or serious injury if you do not follow instructions.

NOTE

Gives you helpful information.

⚠WARNING

Do not disassemble, remodel (including change of printed circuit board) or repair.

An injury or failure can result.

Do not operate beyond specification range.

Fire, malfunction or controller damage can result. Please use it after confirming the specification.

Do not operate in atmosphere of an inflammable, an explosive and corrosive gas.

Fire, an explosion and corrosion can result. This controller is not an explosion-proof type.

Prepare the double interlock by another system (Mechanical interlock etc.) and check operating normally, when using this controller for an interlock circuit.

An accident by a malfunction may potentially result.

These instructions must be followed while in maintenance ; Turn off the power supply, stop the supplied air, exhaust the residual pressure and verify the release of air before performing maintenance.

Otherwise it can cause injury.

NOTE

Follow the instructions given below when handling your controller. Otherwise, the controller may be damaged or may fail, thereby resulting in malfunction.

- Do not drop it, bring it into collision with other objects or apply excessive shock (980m/s² or more).
- Do not pull the lead wire with force or lift the controller by holding the lead wire. Pulling strength is as follows.
 - Power and output lead wire : less than 50N
 - Lead wire with connector for sensor : less than 25N
- Do not use in place which oil or chemical splashes.
- Perform wiring and cable correctly.
- Do not perform wire or cable while power is on.
- Do not use wire or cable with power cable or high-voltage cable in the same route.
- Connect Terminal FG to the ground when using a switching regulator obtained on the commercial market.
- Insert a noise filter (line noise filter, ferrite element or other element) between the switching regulator and controller when analog output is used.
- Do not insert and pull pressure sensor (connector) with the power turned on.
- Do not press the buttons with a sharply pointed tool.
- Start measurement three seconds after turning the power on. Measurement output will be OFF for the first three seconds after turning the power on.
- Warm-up for 20 to 30 minutes when detecting fine pressure. Initial drift of about $\pm 1\%$ F.S. occurs immediately after turning the power on.

Model Indication Method

PSE20□-□□□

Option 2**No Symbol** : None**4C** : Connector for Sensor Lead Wire (4pcs)**Option 1****No Symbol** : None**A** : Panel Mount Adapter**B** : Panel Mount Adapter

+ Front Face Protective Cover

Unit Specification**No Symbol** : Unit selection function provided (NOTE 1)**M** : SI units fixed (NOTE 2)**Input / Output Specification****0** : NPN open collector 5 outputs + Auto shift Input**1** : PNP open collector 5 outputs + Auto shift Input

NOTE 1 : The new Measurement Law prohibits use in Japan of controller with a unit selection function.

NOTE 2 : Fixed unit for compound, vacuum, low pressure is : kPa
for positive pressure is : MPa

Name and Functions of Individual Parts

Main Unit

Switch Output Lamp : Lit when OUT1 (CH1 to CH4) and/or OUT2 (Red) (CH1 only) is ON.

LCD Display : Displays the current status of pressure, setting mode, (Orange) selected indication unit and error code.

△ Button : Selects a mode and increases a set ON/OFF value.

▽ Button : Selects a mode and decreases a set ON/OFF value.

SET Button : Changes the mode and sets a set value.

Unit Display : Lit ON the indicator of selected unit. For the controller (Orange) without unit selection function, the unit is fixed to SI (MPa or kPa).

Unit label : Attach the unit label (kgf/cm², bar, PSI, inHg, mmHg) with a unit selection function.

Channel Indicator : Indicate the channel (1 to 4) that is selected at (Red) that time.

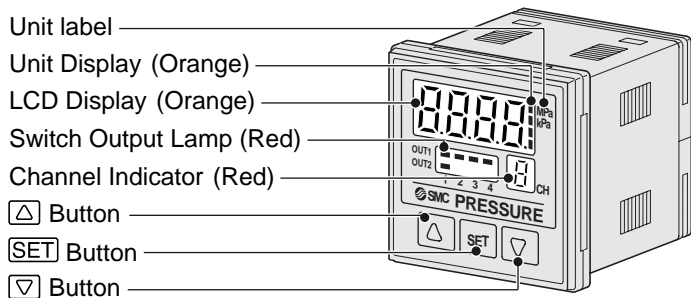

Accessories

Power and Output Lead Wire with Connector (2m) : **ZS-26-A**

Options

Connector for Sensor Lead Wire (1pc) : **ZS-28-C**

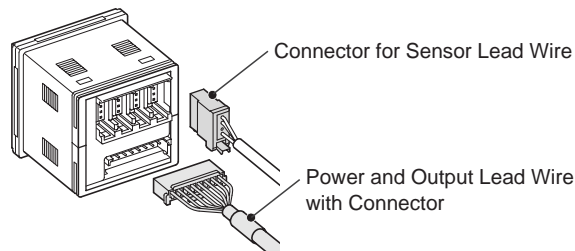

Panel Mount Adapter with set screws M3 × 8L (2pcs) : **ZS-26-B**

Panel Mount Adapter with set screws M3 × 8L (2pcs)

+ Front Face Protective Cover : **ZS-26-C**

Front Face Protective Cover with waterproof seal : **ZS-26-01**

□48 Conversion Adapter : **ZS-26-D**

(It is an adapter for attaching PSE200 series)
(in the panel cut size of PSE100 series.)

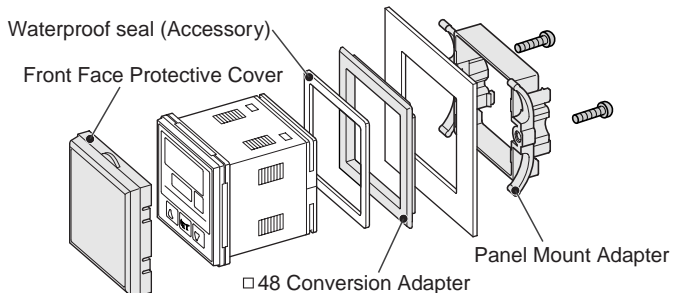

Installation

Mounting by Panel mount adapter

- Fix the panel mount adapter to the controller with the set screws M3 × 8L (2pcs) as attached.

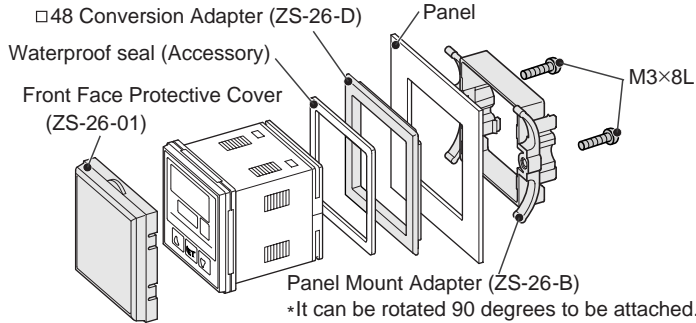

- *Front panel of this controller meets IP65 (if □48 conversion adapter is used, it meets IP40). However, if the panel mount adapter is hold enough with screw and the instrument is not seated correctly, water might enter. Screw shall be tightened 1/4 to 1/2 turns more after touched correctly.

Panel Cut Dimensions

Panel thickness : 0.5 to 8mm

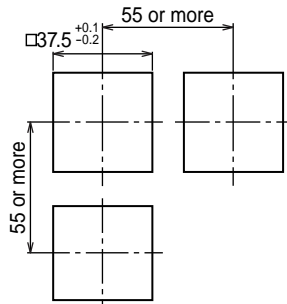

Connection

- Make connection after turning the power off.
- Install the lead wire separately from the route for power cable or high-voltage cable. Otherwise, malfunction may potentially result due to noise.
- Be sure to ground Terminal FG when using a switching regulator obtained on the commercial market.

If analog output is performed connecting to a switching regulator obtained on the market, switching noise will be superimposed and product specification can no longer be met. That can be prevented by inserting a noise filter, such as a line noise filter and a ferrite element, between the switching regulator and the controller, or by using a series power supply instead of a switching regulator.

Notice when removing the controller

- The controller with panel mount adapter can be removed from facility after removing two screws as shown in a figure, by making insert the suitable thin card for the hook of both the sides, pull a panel mount adapter to the front, and remove it. If panel mount adapter is drawn forward with nail caught, the adapter and controller may be damaged.

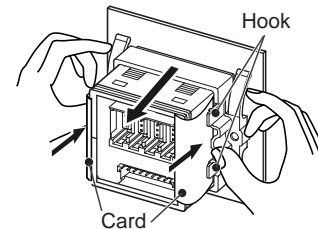

Attaching the connector to the lead wire

- Sensor wire is stripped as shown in the right figure. (Refer to the appended table on page 30.)
- The core of the corresponding color shown in the following table is put into the pin of the number stamped on the connector for sensor connection to the back.

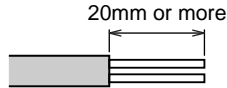

Pin No.	Wire Color
1	Brown (DC+)
2	NC
3	Blue (DC-)
4	Black (IN : 1 to 5VDC)

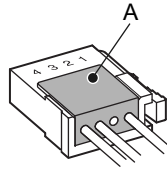

- It checks that the above-mentioned preparation work has been performed correctly, and A part shown in right figure is pushed by hand and makes temporary connection.
- A part center is straightly pushed in by tools, such as pliers.
- Re-use cannot be performed once it connects the connector for sensor connection completely.
- When you fail in the connection mistake of a core and a pin, or the plug of wire, please use the new connector for sensor connection.

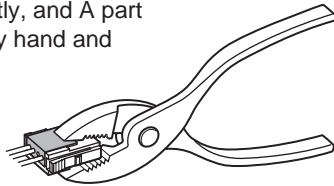

Connector

Connector Connecting/Disconnecting

- When connecting the connector, insert it straight onto the pin and lock the connector into the square groove in the housing until connector clicks.
- When disconnecting the connector, push down the lever by thumb to disengage the lever claw from the square groove. Then pull out the connector straight.

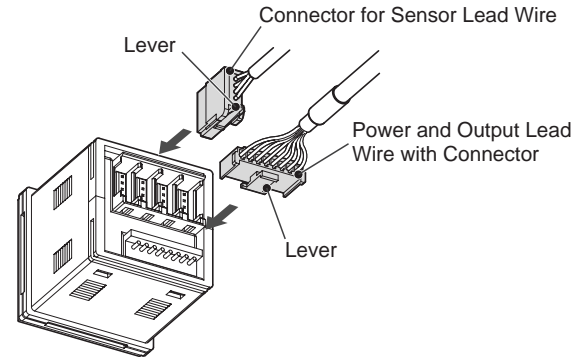

Pin No. of the connector for power and output lead wire

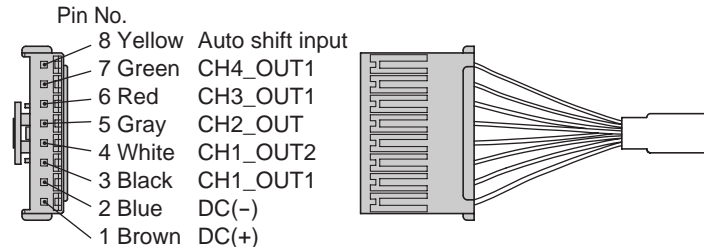

Example of Internal Circuit and Wiring (continue)

Output Specification

When the lead wire with SMC Power and Output Lead Wire (type ZS-26-A) is used, the colors of wire (Brown, Blue, Black, White, Gray, Red, Green, Yellow) will apply as shown on circuit diagram.

PSE200-(M) □: NPN Open Collector Five outputs+Auto shift Input
Max. 30V, 80mA Residual voltage 1V or less

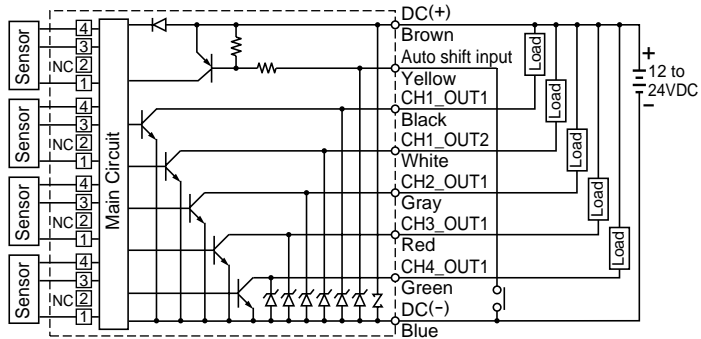

PSE201-(M) □: PNP Open Collector Five outputs+Auto shift Input
Max. 80mA Residual voltage 1V or less

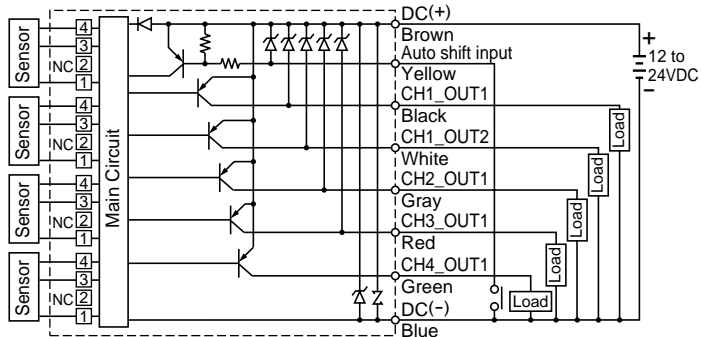

Setting

Setting Procedures

Measurement Mode

For connecting at least 1 sensor other than PSE530 series.

For connecting only PSE530 series.

Auto identification function resetting

Initialize

Pressure range, output mode, response time and auto/manual setting.

Pressure Setting

Input a set value for pressure to perform switch output.

Special Setting

Select or Set Fine adjustment of displayed value, Copy setting, Auto shift, Auto identification.

Measurement Mode

Detects pressure, displays values and performs switching. Other functions such as zero clear can also be set if necessary.

Auto identification function resetting

- Press the button and button at the same time longer than two seconds to display [FSt].
- Press the button three times. ([FSt] displays in order of [CPy] [SH1] [Aon].)
- If [Aon] is displayed, press the or button to display [AoF], and then press the button.
- * Setting for the Auto identification function is ON when units are shipped from the factory.

(Auto identification ON) Aon ⇔ AoF (Auto identification OFF)

Initialize

Select the setting channel by pressing the \square button and keep pressing the SET button longer than 2 seconds. Initialize can get started.

1. Pressure Range Setting

- Select the pressure range suitable for the sensor connected. (Refer to the page 29 for the labels printed the units stuck on the display part)
- Press the \square or \square button and select the pressure range. Press the SET button to set.

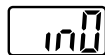

in0 \leftrightarrow **in1** \leftrightarrow **in2** \leftrightarrow **in3**
 (For Compound) (For Vacuum) (For Low Pressure) (For Positive)
 ($\pm 101\text{kPa}$) (-101kPa) (101kPa) (1MPa)
 [Default]

Note) When automatic identification mode is set, it is changed to pressure range of connected pressure sensor (Series PSE530) when power is supplied.
 When range setting is changed, pressure set value changes. So conduct pressure setting again.

2. Selecting Display Unit

(Only when unit switch function is built in.)

Refer to page 16.

3. Output Method Setting

1) The output style for OUT1 is set.

- Press the \square or \square button and select the normally open or the normally closed. Next, press the SET button to set.

(Normally open) 1n0 \leftrightarrow 1nC (Normally closed)

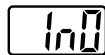

2) The operating mode and the output style for OUT2 is set. (CH1 only)

- Press the \square or \square button and the SET button to set, as in OUT1.

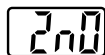



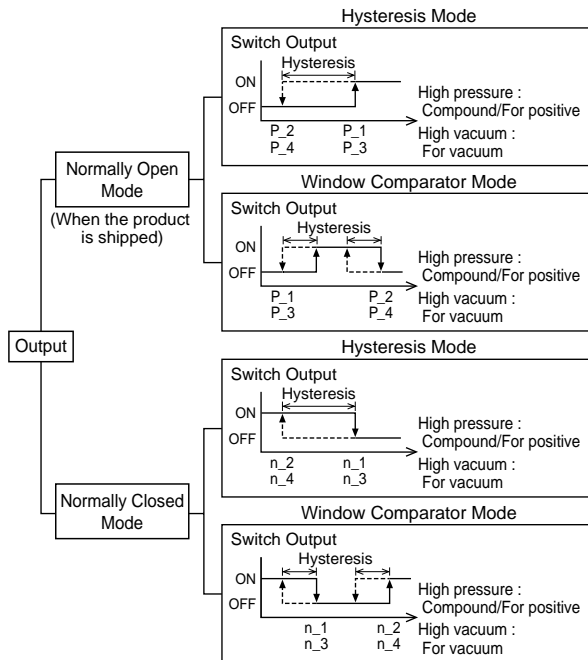

(Normally open) 2n0 \leftrightarrow 2nC (Normally closed)

Output Mode Selection







- The following is given using OUT1 as an example. The descriptions for OUT2 are the same as those for OUT1, under the conditions that [n₁] and [n₂] should be replaced by [n₃] and [n₄], [P₁] and [P₂] should be replaced by [P₃] and [P₄].
- If input pressure fluctuates around the set point when hysteresis is set at 2 digits or less in hysteresis mode, switch output may cause chattering
- Hysteresis is fixed at 3 digits in window comparator mode. When the pressure is set, the space of 7 digits at min. needs to be taken. → The space below 7 digits doesn't allow the operation.

4. Response Time Setting

- A response time for switch output can be set as user desires. 
- Set the optimum response time to prevent the chattering of a switch. The response time currently set will be displayed. Select a desired response time by pressing the  or  button. Press the  button to set.

Response time 5 ⇔ 20 ⇔ 160 ⇔ 640

5. Pressure setting

- There are two methods for pressure set-up : manual and auto preset, either one of which can be selected. The auto preset is provided for an automatic optimum set-up by using a sample for a case in which switch output is used to check absorption. 
- An operation mode currently selected is displayed. Press the  or  button to select the set-up method to be used. Press the  button to set.



(Manual Setting) nAn ⇔ AUt (Auto Preset)



- All the setting mode will be completed and return to the Measurement mode.

Selecting Display Unit

When unit switch function is built in.

The indication unit can be selected freely.

Pressing the  or  button will change the unit and will automatically convert set values.











Press the  button to set and to move to setting the output mode. 

LCD Display		PA	GF	bAr	PSi	inH	n̄nH
Unit	For compound and vacuum	kPa	kgf/cm ²	bar	psi	inHg	mmHg
	For low pressure	kPa	kgf/cm ²	bar	psi	/	/
	For positive	MPa	kgf/cm ²	bar	psi	/	/









Manual Setting

Manually set a set value of the controller. Pressure setting is made for respective channel.







1. Selection of OUT1 [P_1] setting mode

- Press the  button during the Measurement mode to select channel, and then, press the  button to display set values. 
- [P_1] and the current set value will flicker alternately. (In case the Normally Closed mode is selected in initialization, [n_1] and the set value will flicker alternately.)
- Set  button or  button to change and set the set value.  button to increase the value,  button to reduce. Value increases by one digit, per a push on  button. It continues to decrease with keeping push. Value decreases by one digit, per a push on  button. It continues to increase with keeping push.
- Check the corrected value, then press the  button.



2. Selection of OUT1 [P_2] setting mode

- [P_2] and the current set value will flicker alternately. (In case the Normally Closed mode is selected in initialization, [n_2] and the set value will flicker alternately.) 
- Set  button or  button to change and set the set value.  button to increase the value,  button to reduce. Value increases by one digit, per a push on  button. It continues to decrease with keeping push. Value decreases by one digit, per a push on  button. It continues to increase with keeping push.
- Check the corrected value, then press the  button.

3. Selection of OUT2 [P_3, P_4] setting mode (CH1 only)

- Set  button or  button to change and set the set value as in 1,2. 
- Value increases by one digit, per a push on  button. It continues to decrease with keeping push.
- Value decreases by one digit, per a push on  button. It continues to increase with keeping push.
- Check the corrected value, then press the  button.



4. Auto shift compensation value setting

- [C_5]/[C_3] (for CH2 to CH4) and Auto shift corrected value will flicker alternately. Without Auto shift input setting, correction value displays Zero. 
- Check the corrected value, then press the  button.
- The pressure setting mode will be completed and return to the Measurement mode.

Auto Preset Setting

In case auto preset is selected in Initialize, this function stores in the memory a pressure setting value, which is calculated from a measurement pressure as a reference value. The set value of controller is automatically set to an optimum value by repeating absorption and non-absorption several times with a sample, which is to be set up.



1. Selection of OUT1 auto preset mode

- Press the  button during the Measurement mode to select channel, and then, press the  button to display [AP1]. 

2. Preparation of unit for OUT1

- Prepare a unit for which pressure for OUT1 is to be set.





3. Selection of auto preset value of OUT1 setting

- Press the  button to display [A1L].
- Operate system so that pressure may change.
- Detection will be made and a set value will be stored in the memory automatically.
(In case OUT1 setting is not necessary, press  button and  button at the same time longer than one second to skip into [AP2].)

4. Selection of OUT2 auto preset mode (CH1 only)

- Press the  button to display [AP2].

5. Preparation of unit and setting for OUT2

- Prepare a unit for which pressure for OUT2 is to be set.
- Press the  button to display [A2L] is displayed and detection will be made and a set value will be stored in the memory automatically.
(In case OUT2 setting is not necessary, press  button and  button at the same time longer than one second to skip into Measurement mode.) 

6. Set up of OUT2 auto preset value

- Press the **[SET]** button to finish the auto preset mode. The mode will return to the Measurement mode.



A pressure setting value in auto preset is as follows.

ON=A-(A-B)/4 A=maximum pressure value

OFF=B+(A-B)/4 B=minimum pressure value

Fine adjustment function of displayed value

This makes no dispersion on CH1 to CH4 each output value, and make same displayed value. It is possible to do fine adjustment within $\pm 5\%F.S.$ (For compound only : $\pm 2.5\%F.S.$) range of the reading data on the displayed value of pressure sensor.

- Press **[▽]** button and **[SET]** button at the same time longer than two seconds to display [FSt]. If fine adjustment is unnecessary, press **[SET]** button while [FSt] is displayed. Move to copy function. 
- Select channel by **[△]** button or **[▽]** button.
- Press the **[SET]** button, and [FSt] and the current value will flicker alternately.
- Increase or reduce value by **[△]** button or **[▽]** button. (It is possible to increase/reduce within $\pm 5\%R.D.$) 
- Check the value, then press the **[SET]** button. [FSC] and the adjusted value(%) will flicker alternately.
- Press the **[SET]** button to return display of [FSt]. Perform display of [FSt] setting of other channels like the above by **[△]** button or **[▽]** button.
- After setting of other channels in [FSt] display is finished, press the **[SET]** button there. Move to copy function.

Note) When Fine adjustment mode is conducted, pressure setting value is sometimes changed by ± 1 digit.

Copy function

- 1) 5 items such as Pressure setting value, Range setting, Display unit, Output type, Response time are copied.
 - 2) If copied from CH1→CH2, CH3, CH4, CH1 OUT1 information is copied. CH2, CH3, CH4 information is copied only into OUT1 of CH1 if copied from CH2, CH3, CH4→CH1.
- [CPy] is displayed.
 - In case Copy mode setting is not necessary, press the **[SET]** button to skip into Auto shift mode.
 - Select channel to be copied displayed in channel indicator by **[△]** button or **[▽]** button.
 - Press the **[SET]** button so that the channel display of a copied material changes from blink to lighting.
 - [CPy] and the channel to be pasted will flicker alternately. Next, select channel to be pasted by **[△]** button or **[▽]** button.



C_1 (CH1) ⇔ C_2 (CH2) ⇔ C_3 (CH3) ⇔ C_4 (CH4)

- Press the **[SET]** button, and return to [CPy] display.
 - **[△]** button or **[▽]** button is pushed again and the same operation is repeated to copy other channels.
 - After setting is finished, moved from [CPy] display to Auto shift mode.
- Note) When Copy mode is conducted, pressure setting value is sometimes changed by ±1digit.

Auto shift function

This function corrects the setting value of each switch output according to change of pressure source. Even if pressure source is changed, this can do correct decision on switch output. Refer to page 24 or 25 for detail.

- Press the **[△]** button or **[▽]** button in the state where [SH1] is displayed, and [CH1] and [on]/[oF] will flicker alternately. Pushing **[SET]** button with the indication of [SH1] makes it shifted to the auto identification mode.



(Auto shift ON) on ⇔ oF (Auto shift OFF)

- Select Auto shift mode by **[△]** button or **[▽]** button, and press the **[SET]** button.
- Similarly, [CH2], [CH3] and [CH4] press the **[△]** button or **[▽]** button, and select Auto shift mode.
- After Auto shift mode setting of all channels is finished, if the **[SET]** button is pressed, it will shift to Auto identification function.

Auto identification function

This function identifies pressure range of pressure sensor connected to this controller. When [Aon] is set at the Auto identification mode, and when re-applied power at [Aon] status, this function actuates. (Special pressure sensor (SMC PSE530 series) is applicable to this function. Other pressure sensor is not applicable.)

- Select Auto identification mode by **[△]** button or **[▽]** button, and press the **[SET]** button.
- All the setting mode will be completed and return to the Measurement mode.

About Auto shift function

This function corrects the setting value of each switch output according to change of pressure source. Even if pressure source is changed, this can do correct decision on switch output.

With Auto shift

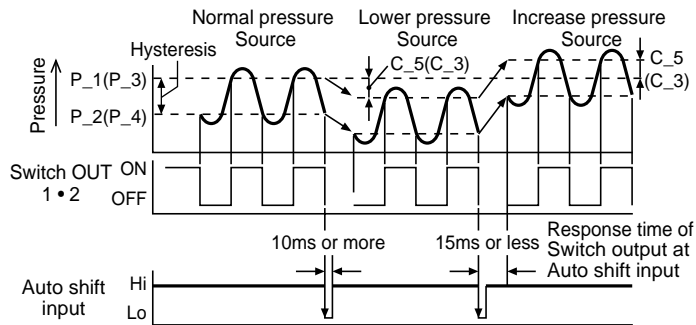

Using with Auto shift input, accepted set range is like below.

	Pressure range				
	-1MPa	-100kPa	0	100kPa	1MPa
For Compound		-101kPa	101kPa	101kPa	
For Vacuum		-101kPa	10kPa	10kPa	
For Low pressure		-10kPa	10kPa	10kPa	
For Positive		-100kPa	1MPa	1MPa	

Legend: Set pressure range Accepted set range





Conditions and explanations for Auto shift function



- Keep constant pressure for 10ms or more from the close signal of Auto shift input.
 - At Auto shift input, display indicates [ooo] for approx. 1 sec. And the pressure at that time is memorized to [C_5] or [C_3] as corrected value. The switch set as Auto shift mode at the time of initial setting operates with the value which applied corrected value [C_5]/[C_3] to setting value.
 - CH1 will operate with Auto shift function.
 - The operating value of OUT1, OUT2 applies corrected value [C_5] to the set value [P_1] to [P_4] or [n_1] to [n_4].
 - CH2 to CH4 will operate with Auto shift function.
 - The operating value of OUT1 applies corrected value [C_3] to the set value [P_1], [P_2] or [n_1], [n_2].
 - Span is 15ms or less until switch output perform soon after Auto shift input.
 - When corrected set value exceed the set pressure range with Auto shift input, the value is changed to be within the range of set pressure.
 - When Auto shift function is turned off, corrected value becomes zero.
 - When Auto shift function of all channels is turned off, even if Auto shift input is Lo (Non Voltage input) does not show [ooo].
 - Correct value [C_5] or [C_3] after Auto shift input vanish when off the power.
 - Correct value [C_5] or [C_3] for Auto shift input function is reset as zero (Initial value) when re-supplied power.
- Note) No EEPROM in the memory of corrected value.

Other Functions

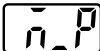
Peak and Bottom Hold Display Function

Maximum and minimum values are always detected and updated during measurement. Displayed values can be held.

- Press the  button longer than 2 seconds.
- Select Peak/Bottom mode by  button or  button,  and press the  button.
 - \bar{n}_P (Peak mode) : Flickers the maximum pressure value.
 - \bar{n}_b (Bottom mode) : Flickers the minimum pressure value.
 - \bar{n}_n (w/o Peak/Bottom mode) : Return to the Measurement mode.





\bar{n}_P  \bar{n}_b  \bar{n}_n
(Peak mode) (Bottom mode) (w/o Peak/Bottom mode)

- To reset holding, press the ,  or  button.





Key Lock Function

This function prevents errors such as changing a set value by mistake. Set [LoC] (lock mode) in order not to accept button operation.

Lock





- Keep pressing the  button longer than four seconds.  Remove the finger off the button when [UnL] is displayed.
- Press the  button or  button to set the display to [LoC].
- Pushing  button makes it shifted to the Measurement mode.

Unlock

- Keep pressing the  button longer than four seconds.  Remove the finger off the button when [LoC] is displayed.
- Press the  button or  button to set the display to [UnL].
- Pushing  button makes it shifted to the Measurement mode.

Zero Clear Function



For measured pressure in ambient pressure and within the range of $\pm 5\%$ F.S. (For compound pressure only, $\pm 2.5\%$ F.S.), displayed value can be adjusted as zero.

- Press continuously the  and  buttons simultaneously more than one second to reset to "0" on the display. Please press  button before  button. In case of pressing  button first, channel select function may operate.
- The mode will return to the Measurement mode automatically.

Channel selects Function

- Per one push  button, channel selection can be done, like [1→2→3→4→1...]. Display shows pressure value, which is measured at the channel selected.

Channel scans Function

- Keep pressing  button for two seconds or more. It changes indicating the channel indicated ever two seconds and measuring pressure corresponding with it.
- To reset this function, press  button again for two seconds or more.

Other Functions (continue)

Error Display Function

This function displays error location and nature when a problem or an error occurs.

Error name	Error display	Contents	Disposition
Over current error	OUT 1 Er 1	Over 80mA load current of switch output flows.	Off the power, remove the output cause that brought over current, and re-input power.
	OUT 2 Er 2		
Residual pressure error	Er 3	Performing zero reset, ± 5 %F.S. (For compound : ± 2.5 %F.S.) or more pressure applied to ambient pressure. *After 2 sec., measurement mode recovers automatically.	After changing an applied pressure into ambient pressure, re-perform zero reset.
Applied pressure error	---	Pressure over max. limit of set pressure range is applied.	Check connection and wiring of a sensor. And set back an applied pressure into within set pressure range.
	----	A sensor has the possibility of un-connecting/miswiring, or pressure over min. limit of set pressure range is applied.	
System error	Er 5	Internal data error causes this display.	Off the power, and re-input power.
	Er 6	Internal data error causes this display.	
	Er 7	Internal data error causes this display.	
	Er 8	Internal data error causes this display.	

• If the above remedy can't recover the operation, the error needs to be investigated at SMC.

Unit Label

How to use the labels printed the units.

In order to display the selected unit, the unit label according to the pressure range or the display unit is attached.

When unit selection function is not provided.

Use the suitable label in the following labels by setup of the pressure range.

LCD Display	in0 (Compound)	in1 (Vacuum)	in2 (Low press.)	in3 (Positive)
Unit Label	kPa			MPa

When unit selection function is provided.

Use the suitable label in the following labels by setup of the display unit.

	LCD Display	PA	GF	bAr	PSi	inH	mmHg
Unit Label	For compound/vacuum	kPa	kgf/cm ²	bar	psi	/	/
	For low pressure	kPa	kgf/cm ²	bar	psi	/	/
	For positive	MPa	kgf/cm ²	bar	psi	/	/

Appended Table

The connector, which suits the lead wire used, is shown in following Tables.

Lead Wire Table

AWG NO.	Conductor size (mm ²)	Overall Diameter (mm ²)	Color of cover	SMC Product No. (1pc)
26-24 (28)	0.14-0.2 (0.08)	φ 0.8 to φ 1.0	Red	ZS-28-C
		φ 1.0 to φ 1.2	Yellow	ZS-28-C-1
		φ 1.2 to φ 1.6	Orange	ZS-28-C-2
22-20	0.3-0.5	φ 1.0 to φ 1.2	Green	ZS-28-C-3
		φ 1.2 to φ 1.6	Blue	ZS-28-C-4

Specification

		PSE20※			
Set pressure range	-0.1 to 1MPa	10 to -101kPa	-10 to 101kPa	-101 to 101kPa	
Pressure range *1	For positive	For vacuum	For low press.	For compound	
Rated pressure range	0 to 1MPa	0 to -101kPa	0 to 101kPa	-101 to 101kPa	
Power supply voltage	12 to 24VDC, ripple (p-p) 10% or less (Protected against inverse connection)				
Current consumption	55mA or less (Except for consumed current of sensor part)				
Power supply voltage for sensor	[Power supply voltage] -1.5V				
Power supply current for sensor	Max. 40mA or less (Max. total consumed current is 100mA for inputting 4 sensors.) *2				
Sensor input	Input signal	1 to 5VDC (Input impedance : Approx. 800kΩ)			
	Number of input	4 inputs			
	Input protection	With over voltage protection (Max. 26.4V)			
	Auto identification	Provided *3			
Hysteresis		Hysteresis Mode : Variable Window Comparator Mode : fixed (3digits)			
Switch output	Output type	NPN or PNP open collector output			
	Number of output	5 outputs (2 points for sensor input CH1, and 1 point for each CH2 to CH4)			
	Max. load current	80mA			
	Max. applied voltage	30VDC (@ NPN output)			
	Residual voltage	1V or less (@ 80mA load current)			
	Output protection	Short circuit protection is provided			
Response time		5ms or less			
Chattering-proof function		20, 160, 640ms selected			
Repeatability		±0.1%F.S. or less			

Specification (continue)

PSE 20 ※		
Indicator accuracy (Ambient Temp. 25°C)	±0.5% F.S. ±1digit	
LCD display	Display for measured value : 4 digits 7-segment (Orange) Display for channel : 1 digit 7-segment (Red) Sampling rate : 4 times/1sec.	
Operation display	Output illuminates at ON (Red)	
Auto shift input	Non-Voltage input (reed/solid state), Input : 10ms or more, Channel independent ON/OFF is possible	
Environment	Enclosure	Front part : IP65 (@ Mounted panel), Others : IP40
	Operating temp. range	Operation : 0 to 50°C, Storage : -10 to 60°C (No condensation, no freezing)
	Operating humidity range	Operation/Storage : 35 to 85% RH (No condensation)
	Withstand voltage	1000VAC, 1 min. (between live parts and case)
	Insulation resistance	50MΩ or more (500VDC M) (between live parts and case)
	Vibration proof	10 to 500Hz smaller one 1.5mm or 98m/s ² double amplitude, each in directions of X, Y and Z for 2 hours
	Impact proof	980m/s ² , 3 times each in directions of X, Y and Z respectively
Temp. Characteristic	±0.5% F.S. or less (25°C)	
Connection	Power supply and output connection : 8P connector, Sensor connection : e-con	
Lead wire	Oil proof cabtire cable with 8 cores (0.15mm ²)	
Material	Body : PBT, Display : Transparent nylon, Rubber cover for the back : CR	
Mass (Weight)	113g (Power and output lead wire included) 55g (Power and output lead wire not included)	

*1 Select pressure range by the initialization.

*2 Over current on Vcc side and 0V side of sensor input connector results in breakage of internal parts of controller.

*3 Pressure sensor that auto identification can be applied is only "PSE500 series". Refer to page 13 and 23 "Auto identification function" for detail.

Outline with Dimensions (in mm)

Dimensions of Main Unit

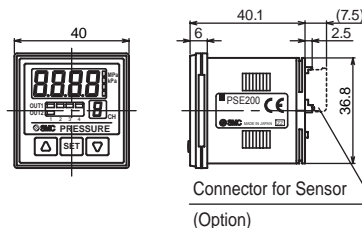

Front Face protective Cover + Panel Mount Type

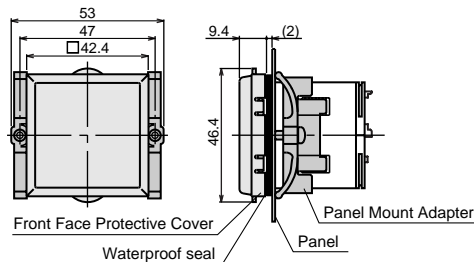

□48 Conversion Adapter + Panel Mount Type

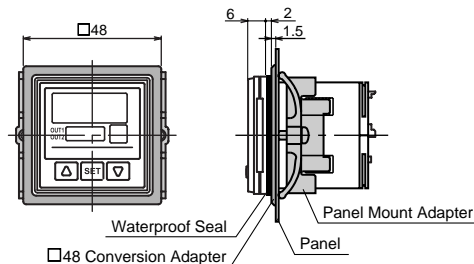

<MEMO>
