

MultiModem[®] GPRS Wireless Modem

MTCBA-G-F4

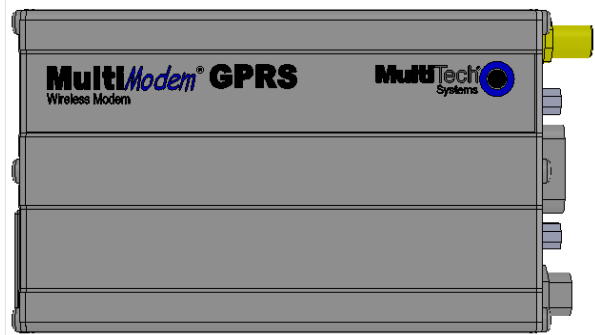

User Guide



MultiModem® GPRS User Guide

Wireless Modem
MTCBA-G-F4
S000443E, Revision E

Copyright

This publication may not be reproduced, in whole or in part, without prior expressed written permission from Multi-Tech Systems, Inc. All rights reserved.

Copyright © 2013 by Multi-Tech Systems, Inc.

Multi-Tech Systems, Inc. makes no representation or warranties with respect to the contents hereof and specifically disclaims any implied warranties of merchantability or fitness for any particular purpose.

Furthermore, Multi-Tech Systems, Inc. reserves the right to revise this publication and to make changes from time to time in the content hereof without obligation of Multi-Tech Systems, Inc., to notify any person or organization of such revisions or changes. Check Multi-Tech's website for current versions of our product documentation.

Revision History

Revision	Date	Description
A	10/03/07	Initial Release
B	11/19/08	Remove fax requirements and minor editorial changes.
C	06/15/2011	Removed references to CDs
D	08/02/2012	Updated regulatory section.
E	12/16/2013	Added UL translations.

Trademarks and Logos

The Multi-Tech logo and *MultiModem* are registered trademarks of Multi-Tech Systems, Inc. Windows is a registered trademark of Microsoft in the U.S. and other countries. Other trademarks and trade names mentioned in this publication belong to their respective owners.

World Headquarters

Multi-Tech Systems, Inc.
2205 Woodale Drive
Mounds View, Minnesota 55112
Phone: 763-785-3500 or 800-328-9717
Fax: 763-785-9874
Internet Address: <http://www.multitech.com>

Technical Support

Country

Europe, Middle East, Africa
U.S., Canada, all others

By Email

support@multitech.co.uk
support@multitech.com

By Phone

+(44) 118 959 7774
(800) 972-2439 or +(763) 717-5863

Warranty

Warranty information can be found at: <http://www.multitech.com>

Contents

Chapter 1 – Product Description and Specifications	5
Product Description	5
Safety	5
General.....	5
RF Safety	5
Vehicle Safety	6
Maintaining Your Modem.....	6
Your Responsibility.....	7
Package Contents.....	7
General Specifications.....	7
Functions – GSM/GPRS Modes.....	7
Electrical Specifications	8
RF Specifications.....	8
Antenna Specifications.....	9
GSM/EGSM Antenna Requirements/Specifications.....	9
Antennas Available from Multi-Tech Systems, Inc.	9
PTCRB Requirements Note	9
FCC Requirements Note	9
Interfaces.....	10
LEDs	10
RS232 15-Pin Connector Pinout.....	10
AT Command Information	10
Chapter 2 – Activation and Installation	11
Activating Your Wireless Account.....	11
Inserting the SIM Card into the Holder	11
Connecting the Antenna, Serial Cable, and Power.....	12
Connecting Two-Piece Transformer Power Supply (International).....	12
Connecting One-Piece Transformer Power Supply (North America)	12
Connecting Optional Direct DC Power	12
Optional – Attaching the Modem to a Flat Surface.....	13
Installing the Modem Driver.....	13
Before you Begin	13
Installing the MultiModem Driver on a PC Running Windows Vista/XP/2003	13
Verifying That Your Modem Has Been Installed Successfully.....	16

Chapter 3 – Using Your Wireless Modem	17
Obtaining a Phone Number for the Wireless Modem	17
Checking Signal Strength and Network Registration	17
Before You Begin.....	17
Downloading the AT reference guide from the Multi-Tech website	17
Verifying Signal Strength	17
Checking Network Registration and Roaming Status	18
Checking the Modem’s Identity	18
Establishing a Voice Call	18
Establishing a Circuit-Switched Data (CSD) Connection	19
Answering a Circuit-Switched Data (CSD) Connection	19
Using Short Message Services (SMS)	20
SMS Examples.....	21
Internet Access	23
Connecting to the GPRS Network for Internet Access	23
Chapter 4 – Troubleshooting and Frequently Asked Questions	26
Troubleshooting Examples.....	26
Situation A: The modem does not answer.....	26
Situation B: The modem always returns «No carrier» when trying to originate a call	27
Frequently Asked Questions	27
Appendix A – Cables	30
Data Cable Diagram – No Voice	30
Data Cable Diagram – with Voice.....	31
Fused DC Power Cable Dimensions	31
Appendix B – Regulatory and Compliance Information	32
47 CFR Part 15 Regulation Class B Devices.....	32
Industry Canada.....	32
Waste Electrical and Electronic Equipment (WEEE).....	33
Instructions for Disposal of WEEE by Users in the European Union.....	33
REACH Statement.....	34
Restriction of the Use of Hazardous Substances (RoHS)	35
Information on HS/TS Substances According to Chinese Standards.....	36
Information on HS/TS Substances According to Chinese Standards (in Chinese)	37

Chapter 1 – Product Description and Specifications

Product Description

The Multi-Tech MultiModem® GPRS is an external data/fax/voice wireless modem. It also supports mobile originated short message service (SMS) and mobile-terminated SMS. It offers standards-based multi-band GPRS Class 10 performance. This ready-to-deploy, standalone modem allows developers to add wireless communication to products with a minimum of development time and expense. The MultiModem GPRS Wireless Modem is based on industry-standard open interfaces, is fully type approved, and can be desktop or panel mounted.

Product codes include:

- **NAM** is the model for US and Canada
- **GB/IE** is the model for Great Britain and Ireland
- **Euro/ROW** is the model for Europe and the rest of the world

Safety

General

The modem is designed for and intended to be used in fixed and mobile applications. “Fixed” means that the device is physically secured at one location and is not able to be easily moved to another location. “Mobile” means that the device is designed to be used in places other than fixed locations.

RF Safety

Due to the possibility of radio frequency (RF) interference, it is important that you follow any special regulations regarding the use of radio equipment. Follow the safety advice given below.

Caution: Maintain a separation distance of at least 20 cm (8 inches) between the transmitter’s antenna and the body of the user or nearby persons. The modem is not designed for or intended to be used in portable applications within 20 cm of the user’s body.

Check your local standards regarding safe distances, etc.

- Operating your device close to other electronic equipment may cause interference if the equipment is inadequately protected. Observe any warning signs and manufacturers’ recommendations.
- Different industries and businesses restrict the use of cellular devices. Respect restrictions on the use of radio equipment in fuel depots, chemical plants, or where blasting operations are in process. Follow restrictions for any environment where you operate the device.
- Do not place the antenna outdoors.
- Switch OFF your wireless device when in an aircraft. Using portable electronic devices in an aircraft may endanger aircraft operation, disrupt the cellular network, and is illegal. Failing to observe this restriction may lead to suspension or denial of cellular services to the offender, legal action, or both.
- Switch OFF your wireless device when around gasoline or diesel-fuel pumps and before filling your vehicle with fuel.
- Switch OFF your wireless device in hospitals and any other place where medical equipment may be in use.

Sécurité RF

En raison de la possibilité d'interférences de radiofréquence (RF), il est important que vous suiviez une quelconque réglementation concernant l'utilisation du matériel radio. Suivez les conseils de sécurité ci-dessous.

ATTENTION: Maintenir une distance d'au moins 20 cm (8 po) entre l'antenne du récepteur et le corps de l'utilisateur ou à proximité de personnes. Le modem n'est pas conçu pour, ou destinés à être utilisés dans les applications portables, moins de 20 cm du corps de l'utilisateur.

Vérifiez vos normes locales touchant les distances de sécurité, etc..

- Fonctionnement de votre appareil à proximité d'autres appareils électroniques peuvent causer des interférences si l'équipement est insuffisamment protégé. Respectez les panneaux d'avertissement et les recommandations du fabricant.
- Différentes industries et les entreprises limitent l'utilisation des appareils cellulaires. Respectez les règlements sur l'utilisation des équipements radio dans les dépôts de carburant, les usines chimiques, ou lorsque des opérations de dynamitage sont en cours. Suivez restrictions pour n'importe quel environnement où vous utilisez l'appareil.
- Ne pas placer l'antenne à l'extérieur.
- Éteignez votre appareil sans fil dans un avion. Utilisant des dispositifs électroniques portables dans un avion peut mettre en danger le fonctionnement de l'avion, peut perturber le réseau cellulaire, et est illégal. Le non-respect de cette restriction peut entraîner la suspension ou le refus des services cellulaires au contrevenant, une action en justice, ou les deux.
- Éteignez votre appareil sans fil lorsque autour de l'essence ou pompes diesel-carburant et avant de remplir votre véhicule avec du carburant.
- Éteignez votre appareil sans fil dans les hôpitaux et tout autre endroit où l'équipement médical peut être utilisé.

Vehicle Safety

- Do not use your MultiModem while driving.
- Respect national regulations on the use of cellular telephones in vehicles. Road safety always comes first.
- If incorrectly installed in a vehicle, the operation of wireless MultiModem telephone could interfere with the correct functioning of vehicle electronics. To avoid such problems, be sure that qualified personnel have performed the installation. Verification of the protection of vehicle electronics should be part of the installation.
- The use of an alert device to operate a vehicle's lights or horn on public roads is not permitted.

Maintaining Your Modem

- In the unlikely event of a fault in the Wireless MultiModem, contact Multi-Tech Technical Support.
- When maintaining your device:
 - Do not attempt to disassemble the device. There are no user serviceable parts inside.
 - Do not expose your device to any extreme environment where the temperature or humidity is high.
 - Do not expose the device to water, rain, or spilled beverages. It is not waterproof.
 - Do not place the device alongside computer discs, credit or travel cards, or other magnetic media. The information contained on discs or cards may be affected by the device.
 - Using accessories, such as antennas, that Multi-Tech has not authorized or that are not compliant with Multi-Tech's accessory specifications may invalidate the warranty.
- If the device is not working properly, contact Multi-Tech Technical Support.

User Responsibility

Respect all local regulations for operating your wireless device. Use the security features to block unauthorized use and theft.

Package Contents

Unbundled Package Modem with No Accessories	Bundled Package Modem with Accessories
1 modem 1 mounting bracket 1 fused DC power cable 1 Quick Start Guide Note: You must supply bracket screws and an antenna.	1 modem 1 mounting bracket 1 antenna 1 serial cable 1 DC power supply/cable (varies) 4 rubber feet 1 Quick Start Guide Note: You must supply bracket screws.

Note: Your wireless provider supplies the SIM card.

General Specifications

Power Requirements	5 V to 32VDC; 400mA Average @5V, 1A Peak @ 5V
Mechanical Dimensions & Weight	4.3" L x 2.4" W x 0.94" H; 4.2 oz. (11 cm x 6.1 cm x 2.4 cm; 119 g)
Connectors & Fasteners	Antenna Connection type: SMA jack Serial Connector: DE15 Pins: RS232 link, audio link, BOOT, RESET Power Connector: 2.5mm miniature power jack SIM receptacle: standard 3V
Operating Temperatures	-30° to +70°C
Storage Temperatures	-40° to +85°C
Humidity	Relative humidity 20% to 90% noncondensing
Certifications	CE Mark, R&TTE EMC: FCC Part 2, 15, 22, 24, EN 55022 & EN 55024 Safety: cUL, UL 60950, EN 60950 Network: PTCRB

Functions – GSM/GPRS Modes

Mode	Description
Standard	Quad Band 850/900/1800/1900 MHz
Interface	Serial interface RS-232. V.24/V.28 Autobauding function.
SMS	Mobile Originated (MO) and Mobile Terminated (MT) SMS Mode Text & PDU point to point. Cell broadcast in accordance with GSM 07.05.
Data	Data circuit asynchronous, transparent, non-transparent up to 14,400 bits
GPRS	Class 10. Coding schemes: CS1 to CS4.

Electrical Specifications

Switching on/off	The device is permanently powered (when connected to the power supply).
Voltage Range	Voltage range : 5 to 32V DC GND : 0V
Over voltage and under voltage	Correct operation of the wireless MultiModem in communication mode is not guaranteed if input voltage falls below 5V.

Input/output electrical characteristics for external connections							
Parameters	GSM/GPRS 850/900			GSM/GPRS 1800/1900			Unit
	Typ.			Typ.			
Input Supply Voltage	5	13.2	32	5	13.2	32	V
Input peak supply current in comm. mode at P_{max}	1	.4	.2	1	.4	.2	A
Input average supply current in comm. mode at P_{max}	360	150	75	300	125	70	mA
Input average supply current in idle mode	30	10	10	30	10	10	mA

RF Specifications

	GSM 850	EGSM 900	GSM 1800	GSM 1900
Frequency RX	869 to 894 MHz	925 to 960 MHz	1805 to 1800 MHz	1930 to 1990 MHz
Frequency TX	824 to 849 MHz	880 to 915 MHz	1710 to 1785 MHz	1850 to 1910 MHz
RF Power Stand	2W at 12.5% duty cycle	2W at 12.5% duty cycle	1W at 12.5% duty cycle	1W at 12.5% duty cycle

Antenna Specifications

GSM/EGSM Antenna Requirements/Specifications

Frequency Range:	824 – 960 MHz / 1710 – 1990 MHz
Impedance:	50 Ohms
VSWR:	<2.0:1
Typical Radiated Gain:	3 dBi on azimuth plane
Radiation:	Omni
Polarization:	Vertical
Wave:	Half Wave Dipole

Antennas Available from Multi-Tech Systems, Inc.

Description	Part Number
Hinged Right Angle 900/1800 MHz Cellular Modem Antenna	ANF1-1HRA
Hinged Right Angle 800/1900 MHz Cellular Modem Antenna	ANF21HRA
Hinged Right Angle 850/900/1800/1900 MHz Cellular Modem Antenna	ANQB-1HRA

PTCRB Requirements Note

There cannot be any alteration to the authorized antenna system. The antenna system must be the same type with similar in-band and out-of-band radiation patterns and maintain the same specifications.

FCC Requirements Note

The antenna gain, including cable loss, must not exceed 3.0 dBi at 1900 MHz / 1.6 dBi at 850 MHz for mobile operating configurations and 7.0 dBi at 1900 MHz / 2.3 dBi at 850 MHz for fixed mounted operations, as defined in 2.1091 and 1.1307 of the rules for satisfying RF exposure compliance.

Interfaces

LEDs

TD	Transmit Data. Lit when modem is transmitting data.
RD	Receive Data. Lit when modem is receiving data.
CD	Carrier Detect. Lit when data connection has been established.
LS	Line Status. Continuous “on” state indicates that the wireless modem is not registered on the network. Flashing state indicates registration on network. Off state. Modem is off (not ready) or in download mode.
TR	Terminal Ready. Commonly called “Data Terminal Ready.” This is a readiness signal from the PC.
PWR	Power. Indicates presence of DC power when lit.

RS232 15-Pin Connector Pinout

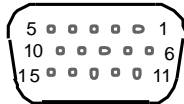

	PIN	EIA	CCIT	Designation
RS-232	1	DCD	109	Data Carrier Direct
	6	RX	104	Receive Data (out)
	2	TX	103	Transmit Data
	8	DTR	108.2	Data Terminal Ready
	9	GND		Signal Ground
	7	DSR	107	Data Set Ready
	12	RTS	105	Request to Send
	11	CTS	106	Clear to Send
	13	RI	125	Ring Indicator
Audio	4	MICROPHONE (+)		
	5	MICROPHONE (-)		
	10	SPEAKER (+)		
	15	SPEAKER (-)		
Boot	3	BOOT		For factory use only.
Reset	14	RESET		To reset, connect to GND momentarily (typical: 2mSec). Open for normal operation.

AT Command Information

AT commands for the GPRS wireless modem are published in a separate reference guide. You can find this guide on the Multi-Tech website.

IP commands for GPRS modems are also published in a separate reference guide. This guide is also included on the Multi-Tech website.

Chapter 2 – Activation and Installation

Activating Your Wireless Account

Some Multi-Tech cellular modems have been pre-configured to operate on a specific cellular network, such as Sprint and Verizon Wireless.

However, before you can begin to use the modem, you must set up a cellular data account with your cellular network provider. Refer to Multi-Tech's Cellular Activation website <http://www.multitech.com/activation.go> for information on activating your cellular modem.

Phone Numbers for the Wireless Modem

Every wireless modem will have its own unique phone number. The phone number may simply be given to you by your wireless service provider or it may be on the SIM card or both. Wireless provider implementations may vary.

Inserting the SIM Card into the Holder

The wireless MultiModem requires the power supply connection to begin operation. It also requires a SIM card (Subscriber Identity Module) to operate on a GSM network.

To install the modem:

1. Using your fingernail or a small wedging tool (e.g., a small screwdriver), pry off the SIM cover.

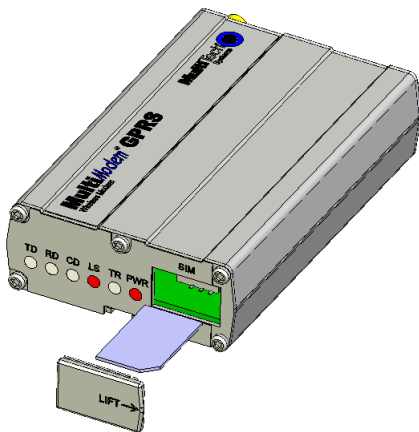

2. Insert the SIM card into the holder.
3. Verify that the SIM card fits into the holder properly and then replace the cover.

Connecting the Antenna, Serial Cable, and Power

1. Connect a suitable antenna to the SMA connector (see antenna specifications on page 9).
2. Connect both sides of the serial and control cable (15-pin Sub D connector on the modem side).
3. Plug the power supply cable into the modem.

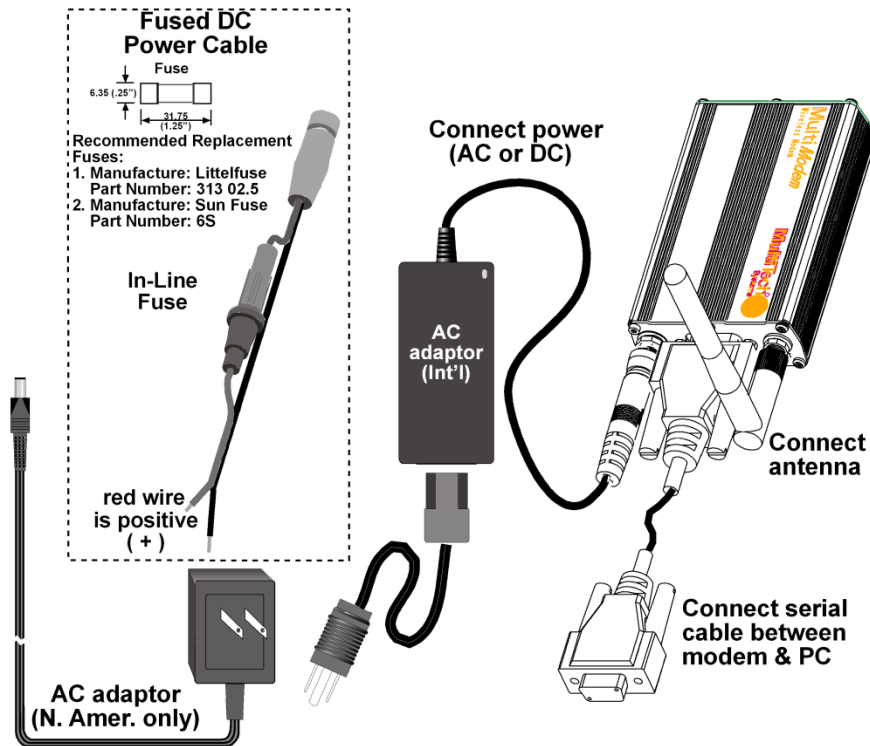

Connecting Two-Piece Transformer Power Supply (International)

1. Connect the AC cord receptacle into the transformer block.
2. Connect the AC cord plug into the mains power outlet.

Connecting One-Piece Transformer Power Supply (North America)

1. Connect between the MultiModem power receptacle and the mains power outlet.

Connecting Optional Direct DC Power

1. Connect the fused DC power cable into the DC power connector on the modem.
2. Attach the two wires at the other end of the fused cable to a DC fuse/terminal block on a vehicle in which you are mounting the MultiModem.
3. Connect red wire to the "+" (positive) and black wire to the "-" (negative). Be sure the GND connection is correct.

Note: Over-voltage protection is provided on the device. For more thorough protection, you may want to add additional filtering to the DC input.

Note: For automotive application: according to the type of application, you can use permanent "+" or key-switched "+". Connect the power supply to its source (for example, in a mobile situation, to the vehicle's DC fuse/terminal block).

Optional – Attaching the Modem to a Flat Surface

To mount the Wireless MultiModem:

1. Obtain mounting screws (two are needed) that are appropriate for the surface on which you will mount the modem. For example, you might use two 6-32 self-tapping screws 5/8" in length to mount the modem in a truck cab, on the wall behind the passenger's seat.
2. Typically you mount the unit against a flat surface where you can drill holes. Separate the mounting holes by 125mm or 4 -15/16 inches, center-to-center.
3. Drill the mounting holes at the desired mounting location.



4. Slide the mounting bridles into the corresponding slots on the backside of the modem chassis.
5. Attach the modem with two screws to the mounting surface at the desired location on the equipment.

Installing the Modem Driver

Before you Begin

- If you are operating the modem on a PC that runs a Windows operating system, download the MultiModem driver from the Multi-Tech website.

Note: If you are running Linux, you don't need a driver for serial modems.

- Make sure your PC's operating system is compatible with the wireless modem. The modem is compatible with Windows Vista, XP, 2003, 2000, and Linux.
- Ensure you have the required equipment handy:
- One MTCBA-G modem
- A RS-232 cable to connect the modem to the

Note: These instructions are a basic guide to help you install the Multi-Tech Wireless modem driver. You may see differences in your setup based upon your version of Windows and your Windows settings.

Installing the MultiModem Driver on a PC Running Windows Vista/XP/2003

These installation steps assume your PC is running a Windows Vista, Windows XP or Windows 2003 operating system.

To install the driver on your PC:

1. From the **Start** menu, select **Control Panel**.
2. In the Control Panel window, double-click **Phone and Modem Options**.

3. In the Phone and Modem Options window, click the **Modems** tab.

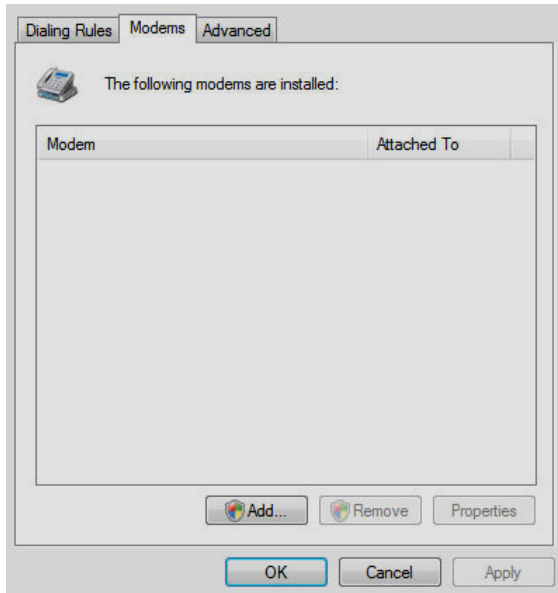

4. To add a new modem, click **Add**.

The Add New Hardware wizard window opens, and steps you through the installation.

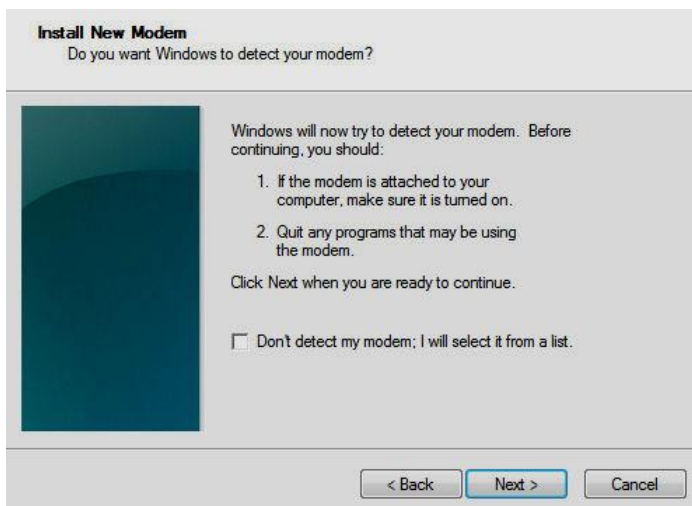

5. On the Install New Modem panel, click **Don't detect my modem, I will select it from a list**.
6. Click **Next**. Another installation wizard panel appears.

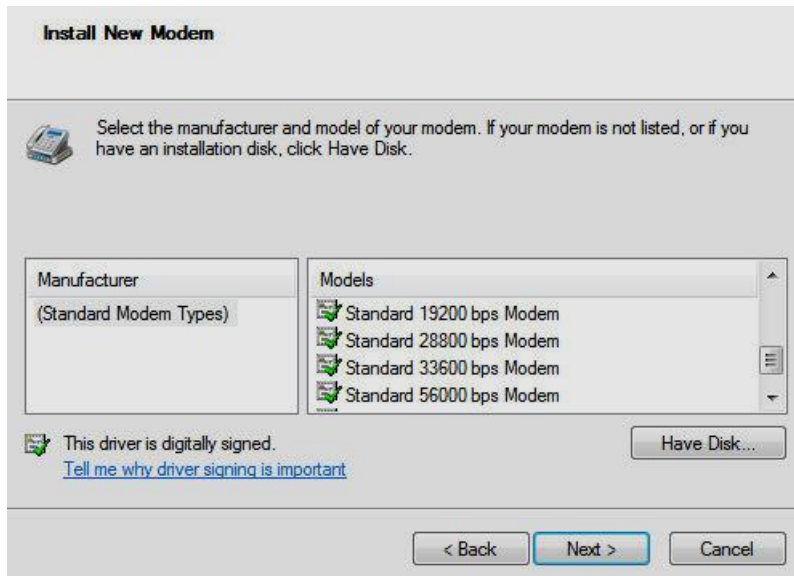

7. To browse for the driver file on your PC, click **Have Disk**. Click **Next**.
8. In the next panel, click **Browse**.

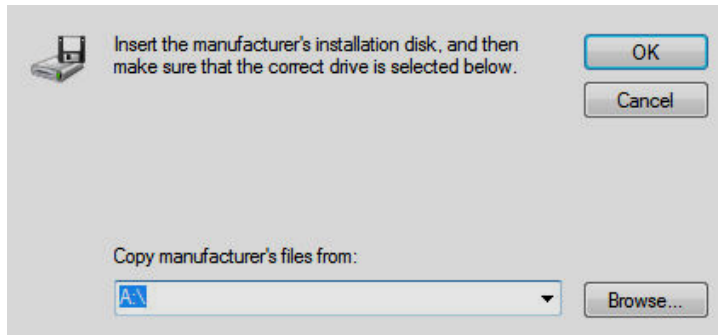

9. Browse to the location where you placed the driver that you downloaded from the Multi-Tech website.
10. Select the driver for your modem and click **Next**.

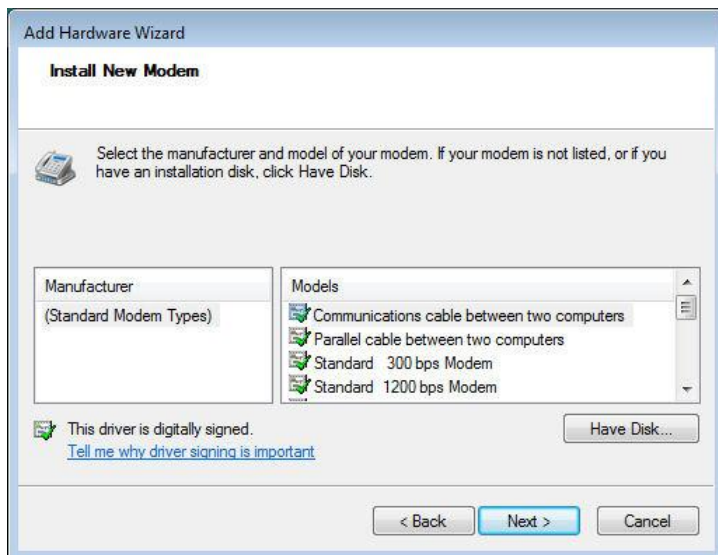

11. The next installation wizard panel asks you to select the com port to which the MultiModem is connected.
 - If you know which port your modem is on, click that port
 - If you don't know the port, select COM1 (most common).

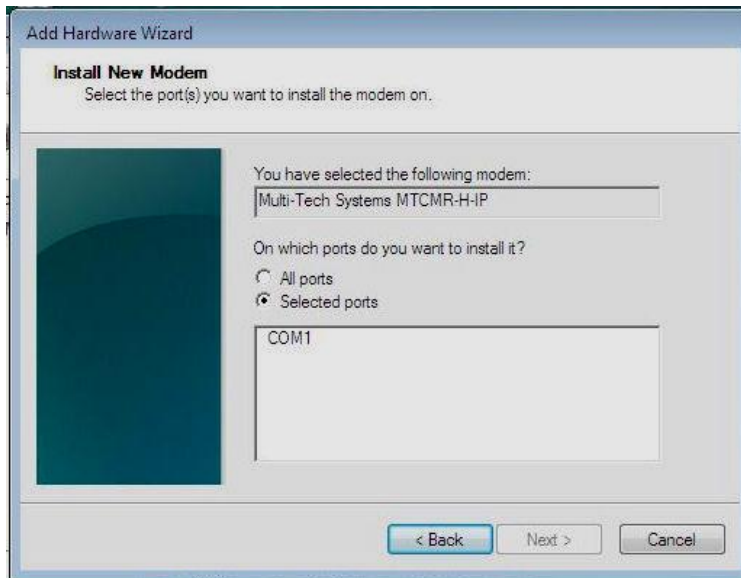

12. Click **Next**.

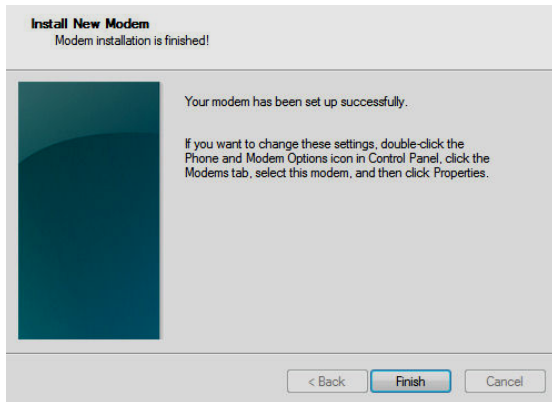

13. To finish the install, click **Finish**.

You have successfully installed the MultiModem driver.

Verifying That Your Modem Has Been Installed Successfully

1. After installing the Multi-Tech modem driver, you return to the Phone and Modems Options window.
2. Make sure that the modem is listed in the **Modem** column. Also ensure that the correct COM port is listed in the **Attached To** column.
3. Highlight the modem. Click **Properties**.
4. A **Properties** window opens. Select the **Diagnostics** tab.
5. Click **Query Modem**. Windows queries the Multi-Tech modem.
6. To make sure that the modem is correctly being queried, check the modem's LED lights.
 - The TR light should be on.
 - The TD and RD lights should flicker.
7. If the query works, the second box shows the columns **Command** and **Response**.
The modem is properly installed and ready for use.
8. To close the modem Properties window, click **OK**.
9. To close the Phone and Modem Options window, click **OK**.

Chapter 3 – Using Your Wireless Modem

This chapter describes how to use your wireless modem. It describes how to check your modem's signal strength and how to ensure your modem is registered on a network.

Obtaining a Phone Number for the Wireless Modem

Every wireless modem has a unique phone number. The phone number may simply be given to you by your wireless service provider or it may be on the SIM card or both. Wireless provider implementations may vary.

Checking Signal Strength and Network Registration

This section describes commands that you can use to check signal strength and roaming status.

Before You Begin

Ensure you have access to a terminal application such as HyperTerminal

To verify signal strength and roaming status, you must use a terminal application such as HyperTerminal. To open this program in Windows XP or Windows 2003, go to **Start > All Programs > Accessories > Communications > HyperTerminal**.

Other Windows operating systems have similar paths to HyperTerminal. If you cannot find the HyperTerminal application, check system's online help file for further information.

Downloading the AT reference guide from the Multi-Tech website

You can use AT commands to operate, configure, and query your modem. You can use the Multi-Tech website to download a reference guide that describes the GPRS commands.

Verifying Signal Strength

1. Using HyperTerminal, type **AT+CSQ**.
2. The modem responds with the received signal strength (rssi).

RSSI ranges from 0 to 31.

Signal Strength Verification – RSSI	
21 – 31	Exceptional
11 - 20	Average
0 - 10	Weak or Insufficient
99	No signal

3. The modem responds with the received signal strength (rssi) and the channel bit error rate (ber). BER ranges from 0 to 7. Seven is the highest error rate.

Checking Network Registration and Roaming Status

To verify that the wireless MultiModem has been registered on the wireless network:

1. Using HyperTerminal, type **AT+CREG?**

The modem responds in one of the following ways:

Network Registration Verification	
Value	Network Registration Status
0,0	The modem is not registered on any network
0,1	The modem is registered on the home network
0,5	The modem is registered on a network and it is roaming

Note: If the modem indicates that it is not registered, verify the signal strength to determine if the problem is the strength of the received signal.

Checking the Modem's Identity

Use the ATl command to check the modem's identity.

1. To display manufacturing data, type **ATl0**

Note: This command uses the capital letter l after **AT**. The command ends in a zero. Manufacturing data displays, for example, Wavecom Modem Multiband G850 1900

2. To display the software version, type **ATl3**

The software version displays, for example, 651_09gg...

3. To display modem data features, type **ATl6**

Modem data features appear, such as data rates, data modes, fax classes.

Establishing a Voice Call

1. Enter PIN code, if one is required by your wireless provider.

- a. Type **AT+CPIN=1234**

- b. Responses include:

OK (PIN Code accepted)

+CME ERROR : 16 (Incorrect PIN Code)

+CME ERROR : 3 (PIN already entered [with +CMEE : 1 mode])

2. To initiate a voice call:

- a. Type **ATD1234;**

Note: Don't forget the semicolon ";" at the end, which indicates voice calls.

- b. Responses include:

OK (Communication established)

CME ERROR : 11 (PIN Code not entered [with +CMEE : 1 mode])

CME ERROR : 3 (Operation not allowed)

3. To initiate an emergency call:
 - a. Type **ATD112;** (Note: Don't forget the semicolon “;” at the end, which indicates voice calls)
 - b. Responses include:

OK
4. To hang up:
 - a. Type **ATH**
 - b. Responses include:

OK

Establishing a Circuit-Switched Data (CSD) Connection

A Circuit-Switched Data Connection makes the wireless modem work similar to a regular analog modem. You must have CSD service in order to make a CSD call.

Note: Your wireless service provider charges airtime usage for these connections.

Establishing a Connection

1. Use HyperTerminal or a terminal application, type the following command:

ATD<phone number>

Notes:

- The phone number you are calling is entered between the displayed brackets. Do not type additional brackets. For example, type only **ATD 8585551212. 8285551212** is typed between the brackets.
- This command tells the modem to inform the wireless network that you are initiating a CSD modem call. If you are dialing to another modem, the remote modem should answer and a connection between the two modems will be established. If you include a semi-colon (;) at the end of the dialing string, the modem will instead initiate a Voice call to the phone number dialed.

Disconnecting

1. To disconnect, type: **+++**
2. Wait about two seconds to see an OK response.
3. Then type: **ATH**

Note: **+++** is the escape sequence and **ATH** is the Hang-up command.

Answering a Circuit-Switched Data (CSD) Connection

A Circuit-Switched Data Connection makes the wireless modem work similar to a regular analog modem. You must have CSD service in order to answer a CSD call.

There are three phone numbers for GSM: the voice number, the data number, and the fax number. All are provided by the carrier.

To answer a call:

1. To establish a connection, call into the modem by dialing the data number provided by your carrier.
2. To answer a call, when you see the RING responses on the terminal screen, enter **ATA <cr>**.
3. To set auto-answer, enter **ATS0=x**

This sets the modem to auto-answer. The call will be answered after the number of rings entered. **x** stand for the number rings.

4. Call the number provided to you by the carrier.

To disconnect:

1. Type: **+++**
2. Wait about one second to see an OK response.
3. Type **ATH**

Using Short Message Services (SMS)

Sending a Short Message to a Specified Number

1. Type **AT+CMGS="8585551212" <press Enter>**
2. Then type your message: **Please call me soon. <press ctrl Z>**
3. The modem may respond with **+CMGS:<mr> OK**

Writing a Message to Memory

You can store a message to send it at a later date.

1. Type **AT+CMGW="8585551212" <press Enter>**
2. Type the message. **<press ctrl Z>**
3. The modem may respond with **+CMGW: 4 OK** (The message is stored in the index as message 4.)

Sending a Message from Storage

1. Type **AT+CMSS=**x**,"8585551212" <press Enter>**
2. The modem may respond with **+CMSS: 1 OK** (The transmission is successful. One SMS message is sent.)

Note: The **x** represents an index location.

Viewing a List of Stored Messages

1. Type **AT+CMGL=**x** <press Enter>**
2. For **x**, substitute one of the following:
 - "**REC UNREAD**" Shows received unread messages.
 - "**REC READ**" Shows received read messages.
 - "**STO UNSENT**" Shows stored unsent messages.
 - "**STO SENT**" Shows stored sent messages.
 - "**ALL**" Shows messages.
3. The modem will respond **AT+CMGL: 1,"REC UNREAD","8585551212",1...**
4. The modem will continue until all UNREAD messages, numbers, and index number are listed.

Reading a Stored Message

1. Type **AT+CMGR=**x** <press Enter>**
2. The modem may respond with **+CMGR: "REC READ", "8585551212",**

Note: The **x** represents an index location.

Deleting a Stored Message

1. Type **AT+CMGD=**x**,**n** <press Enter>**
2. If you want to delete one message at a time, do not enter a value for **n**.

3. For *n*, substitute one of the following:
 - **0** Delete message at location <include the index number>
 - **1** Delete all READ messages.
 - **2** Delete all READ and SENT messages.
 - **3** Delete all READ, SENT, and UNSENT messages.
 - **4** Delete ALL messages.
4. The modem will respond **OK**.

Note: The *x* represents an index location. The *n* stands for the type of messages to delete.

SMS Examples

Send Example

Send an SMS message to another SMS compatible device

at+cmgf=1 (set to text mode)

OK

at+cpms="SM","SM" (set memory storage when writing and sending SMS messages)

+CPMS: 0,50,0,50

OK

at+cmgs="7632273726" (send message to the number specified in quotes)

> **TEST message ONE.** (Type message after the > symbol and hit <CTRL + Z> to send the message)

+CMGS: 52

OK

Receive Examples

Receive Example 1: Receive SMS messages in text mode by saving to SIM memory – Notification via +CMTI unsolicited response code:

at+cmgf=1 (set to text mode)

OK

at+csms=0 (set to Phase 1)

+CSMS: 1,1,1

OK

at+cnmi=2,1,0,0,0 (set to display +CMTI indication when SMS is received)

OK

at+cpms="SM","SM" (set the read and write storage of SMS to SIM)

+CPMS: 0,50,0,50

OK

+CMTI: "SM",1 (indication that message was received and stored to SIM location 1)

at+cmgr=1 (read message stored in location 1)

+CMGR: "REC UNREAD", "+17632273726", "06/03/17,13:55:22+00"

TEST1

OK

at+cmgd=1 (delete message that is stored in location 1)

OK

Receive Example 2: Receive SMS message in text mode by directly routing the received message to the TE through the serial port using Phase 2:

at+cmgf=1 (set to text mode)

OK

at+csms=0 (set to Phase 2)

+CSMS: 1,1,1

OK

at+cnmi=2,2,0,0,0 (set to receive SMS and route directly to TE)

OK

+CMT: "+17632273726",,"06/03/17,13:59:18+00" (message received and directly routed to TE)

TEST2

Receive Example 3: Receive SMS message in text mode by directly routing the received message to the TE through the serial port using Phase 2+:

at+cmgf=1 (set to text mode)

OK

at+csms=1 (set to Phase 2+)

+CSMS: 1,1,1

OK

at+cnmi=2,2,0,0,0 (set to receive SMS and route directly to TE)

OK

+CMT: "+17632273726",,"06/03/17,14:01:17+00" (message received and directly routed to TE)

TEST3

at+cnma (acknowledge that message has been received)

OK

Internet Access

You can setup Internet access in Windows Dial-Up Networking (DUN) of the computer that the wireless modem is serving. Setup procedures vary according to the type of wireless service provider used.

To access Dial-Up Networking on your PC, go to **Start > Settings > Network Connections**.

- For GSM-without-GPRS, a circuit-switched data connection is used. The user can set up DUN to make a conventional V.32 modem connection to any terminating modem at the other end. The phone number specified in DUN can be one supplied by the wireless service provider or another phone number related to a different dialup modem service (e.g., a dialup modem service phone number from any commercial or private dialup network).
- For GSM-with-GPRS, a single DUN number is generally used by all of a wireless provider's subscribers throughout its area of coverage; regional, nationwide, continental, etc. Rather than being a literal phone directory number, as in conventional DUN, this is a code that gives the modem Internet access.

Connecting to the GPRS Network for Internet Access

After you have inserted the SIM card and the modem is ready for use, you can establish an Internet connection through a Windows dial-up session.

Note that your wireless provider will charge you for data usage.

Requirements

- One Multi-Tech wireless GPRS modem
 - The GPRS modem should have an active SIM card and must have GPRS services
 - The modem must be getting a proper signal and be showing a network registration through the wireless provider's network
 - A PC running Windows XP or 2003 with the Multi-Tech drivers installed for your particular model
- The following instructions are for Windows XP SP2 and Windows 2003. Every PC may have slight differences which may cause the instructions to be different. Use these instructions as a guide to help you understand what is required to set up an Internet connection through your wireless service provider for all operating systems.

Note: Cellular providers provide Internet services as part of your service plan. Multi-Tech recommends that if you plan on using large amounts of data, to sign up for an unlimited data service plan with your provider. Multi-Tech Systems, Inc. will not be responsible for any charges on your cellular bill. If you have any questions about billing, service plans, service charges, etc., please contact your provider for more information.

Set the Access Point Name (APN) into the Modem's Properties on Your PC

In order for your GPRS wireless modem to connect to your provider's network, you must tell the modem the Access Point Name (APN) to which it will connect. The APN is a server name that your account is setup on with your provider. Your APN will be given to you by your provider. Here are some well-known APNs:

- AT&T: PROXY, or INTERNET, or PUBLIC
- T-Mobile: INTERNET2.VOICESTREAM.COM, or INTERNET3.VOICESTREAM.COM, or WAP.VOICESTREAM.COM
- Rogers AT&T of Canada: INTERNET.COM

To set the APN:

1. Click the Windows **Start** button, then select **Control Panel**.

2. In the Control Panel, double-click on **Phone and Modem Options**.
3. The Phone and Modem Options window appears. Click the **Modems** tab.
4. Highlight the Multi-Tech wireless modem listed in the table and then click on **Properties**.
5. A Properties window for your modem will display. Click on the **Advanced** tab and you should see an Extra Settings box. In the **Extra initialization commands** text box, type:

AT+CGDCONT=1,"IP", "<APN>"

For <APN>, type in the correct APN for your account.

For example:

AT+CGDCONT=1,"IP", "ISP.AT&T"

6. To close the modem Properties window, click **OK**. Then click **OK** to close the Phone and Modem Options window.

Create Your Dial-Up Connection in Windows XP/2003

1. Click on **Start** and then click on **Control Panel**.
2. In the Control Panel, double-click on **Network Connections**.
3. On the Network Connections screen on the left-hand side under **Network Tasks**, click on **Create a new connection**.
4. The New Connection Wizard should appear. It will walk you through setting up your Internet connection. Click on **Next >** to begin.
5. On the Network Connection Type screen, select **Connect to the Internet**, and then click **Next**.
6. On the Getting Ready screen, select **Set up my connection manually**, and then click **Next**.
7. On the Internet Connection screen, select **Connect using a dial-up modem**, and then click **Next**.
Note: After clicking on Next, you may or may not be asked to select which modem to use. If you have more than one modem installed in your PC, you will be required to select the proper modem to use. If asked, please select the Multi-Tech wireless modem that has been installed.
8. On the Connection Name screen in the **ISP Name** box, type in a name for your new connection. You can give it any name that you would like. After you have typed in a name, click **Next**.
9. On the Phone Number to Dial screen, type in the number that specifies to the modem to connect to your provider's Internet service.
For GPRS modems, type ***99***1#**. Then click **Next**.
10. On the Connection Availability screen, specify if this connection is for anyone's use or for your use only by checking the appropriate button. Click **Next**.
11. On the Internet Account Information window, type the user name and the password for your account.
In many cases, a user name and a password are not required, but some wireless providers require it. Check with your provider to see if they are needed.
12. Check the following two options if you would like them activated:
 - Check the box if you want this account name and password to be used by everyone.
 - Check the box if you want this as your default Internet connection. Then click **Next**.
13. On the Completing the New Connection Wizard screen, your last task is to place a check in the box if you would like to add a shortcut to your desktop. Then click **Finish**.
14. A Connection screen displays on your desktop. Click the **Properties** button on the bottom of this screen.
15. The Properties window will open for you to make your connection. **Important:** Make sure that Use dialing rules is not selected, and then click **OK**.
16. Once back at your Connection screen, to start the connection, click **Dial**.

17. The connection tells the modem to connect to your provider's Internet service. Once connected, you see the connection status icon in your system tray.

You can now open an Internet browser to surf the Internet.

Disconnecting

1. To disconnect, right click on the connection icon in your system tray at the bottom right corner of your screen.
2. Scroll up and click on **Disconnect**.

You are disconnected.

Chapter 4 – Troubleshooting and Frequently Asked Questions

Troubleshooting Examples

Before calling the Multi-Tech Technical Support, check to the following connections:

- The right antenna is connected to the modem
- The serial cable connection is correct
- The power is connected correctly and the power lights on the modem are on
- Verify your signal strength
- Verify your network registration
- Use the following situation examples to troubleshoot the modem not answering and the modem returning a No Carrier message.

Situation A: The modem does not answer

If the wireless MultiModem does not answer through the serial link upon an attempted transmission of data or voice signals, see the table below for possible causes and solutions.

Solutions for 'no connection through serial link' situation		
<i>If the modem returns ...</i>	<i>Then ask ...</i>	<i>Action</i>
(nothing)	Is the communication program properly configured?	In communications program, verify that modem parameters have been set to the values shown here: Data bits = 8 Parity = none Stop Bits = 1 Baud = 115200 bps
	Is another program interfering with the communication program?	Close any such application program.
	Is the modem set to autoanswer?	Type ATS0=1 (to set to auto answer on the first ring) Type ATA (to set to manual answer)
	Is the communication program receiving RING responses?	Type ATS0=1 (to set to auto answer on the first ring) Type ATA (to set to manual answer)

Situation B: The modem always returns «No carrier» when trying to originate a call

Solutions for “no carrier” message		
If the modem returns ...	Then ask ...	Action
no carrier (esp. for data communication)	Is the selected bearer type supported by the called party? Is the selected bearer type supported by the network?	Type AT+CEER to view the extended error code (see “Error Results Codes” in the AT Command guide). Be sure that the selected bearer type is supported by the called party. Be sure that the selected bearer type is supported by the network. If no success, try bearer selection type: AT+CBST=0,0,3 Be sure SIM card is available for data/fax calls.
no carrier (esp. for voice communication)		Be sure that the semicolon character (“;”) is typed immediately after the phone number in the AT command; e.g., ATD#####;

Frequently Asked Questions

Which providers can I use?

- Two major providers are T-Mobile and AT&T.

Does this modem support High-Speed Circuit-Switched Data (HSCSD)?

- No, our GSM/GPRS modems do not support HSCSD.

The modem is answering, but seems to not be doing anything?

- The modem is answering in voice mode.
- If you are trying to make a data call, make sure the account has CSD service. You also need the data number (separate number from the main phone number that is provided by the provider).

I am trying to make a data connection by dialing from my wireless modem to an analog modem. Why does the analog modem answer and send tones, but never connect?

- To make a data call you must use the ATD<number> command.
- Make sure the account has CSD service.

How do I get the voice portion to work so I can talk to others using the wireless modem?

- You need a cable that has the speaker pins connected to a speaker and microphone.
- We have a “Y” cable that splits out to a RJ9 connector that can be used to plug into the receiver of a handset.
- ‘ATD<number>;’ will originate a voice call.

How do I make an Internet connection to my dial-up ISP?

- Make sure you have CSD service.
- Create a dial-up connection to the ISP's access number, then use your account username and password and choose the wireless modem as the device.

How does faxing work?

- GPRS modems support Class 1 and Class 2 Group 3 faxing.
- You need fax services setup on your account. You should receive a separate phone number for fax just like voice and data, and you must call the fax number for the modem to receive a fax.
- You also need fax software (we do not have working software). WinFax Version 10 has been tested with success.

I can't make outgoing calls. I just receive a NO CARRIER response.

- Make sure the antenna is connected and SIM is inserted correctly.
- Check signal and registration: 'AT+CSQ' (10-31 is good), 'AT+CREG?' (0,1 is registered & 0,5 is roaming).
- Check NO CARRIER reason with 'AT+CEER'. Look up error code in Reference Guide.

The modem will not answer.

- To have modem autoanswer, set modem with 'ATS0=1' and 'AT&W' to store the setting.
- Send 'ATA' to the modem once the RING is indicated on the terminal screen.
- You may need to set modem to ignore DTR, 'AT&D0', if you aren't providing DTR.

I am trying to make a GPRS connection using a Windows dial-up session. It connects and then immediately disconnects.

- Make sure the APN is configured in the modem correctly (The APN is provided by the provider).
- Check the APN with 'AT+CGDCONT?' To make sure it is correct.
- If no APN is inserted, then insert the correct APN using the command 'AT+CGDCONT=1,"IP","<APN>"' with HyperTerminal or add it into the "Extra Initialization Commands:" in the modem's properties.
- Make sure the APN is correct for your account.

When I try to establish a GPRS connection using Windows dial-up I get an error: "Hardware Failure".

- Check the modem to make sure it is installed and can be queried in the modem's properties.
- Make sure the com port is not being held by another application. Look for the TR light indication. If it is on, most likely another application is holding on to the port.
- Make sure the dial-up connections maximum speed matches the modem's properties maximum port speed.
- Try rebooting the PC.

What is the maximum amount of characters I can use to send an SMS message?

- Supports up to 160 characters maximum.
- In PDU mode using 7-bit, the modem still supports 160 characters, but in 8-bit the modem supports only 70 characters.

After changing the +CNMI, +CSCA, or +CSMP command values, the modem doesn't store them.

- When changing these command values, you must use the +CSAS command to store the changes.

How do I send an SMS message to an email account?

- When sending an SMS message to an email account, use a designated routing number that tells the SMS server to route your message to an email account. Here are the numbers that we are aware of at this time:

AT&T = "0000"

T-Mobile = "500"

Here is an example of how to send an SMS message to an email account:

AT+CMGS="0000"

> email@multitech.com My message goes here. <ctrl +Z>

Appendix A - Cables

Data Cable Diagram - No Voice

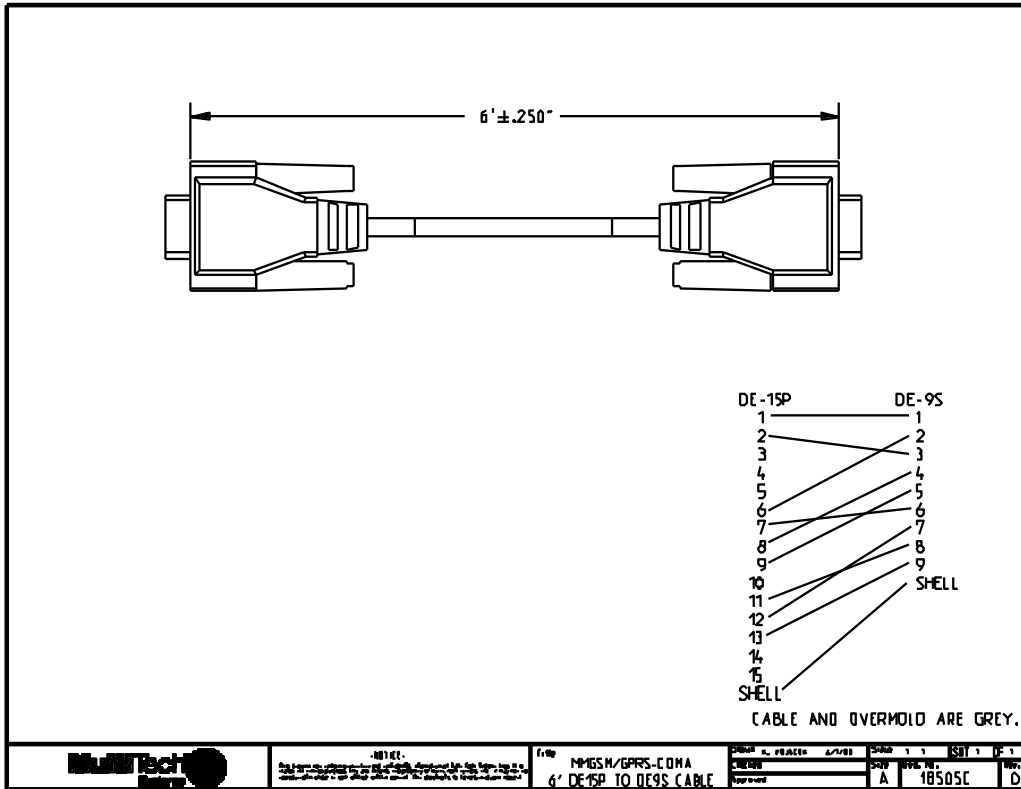

Data Cable Diagram – with Voice

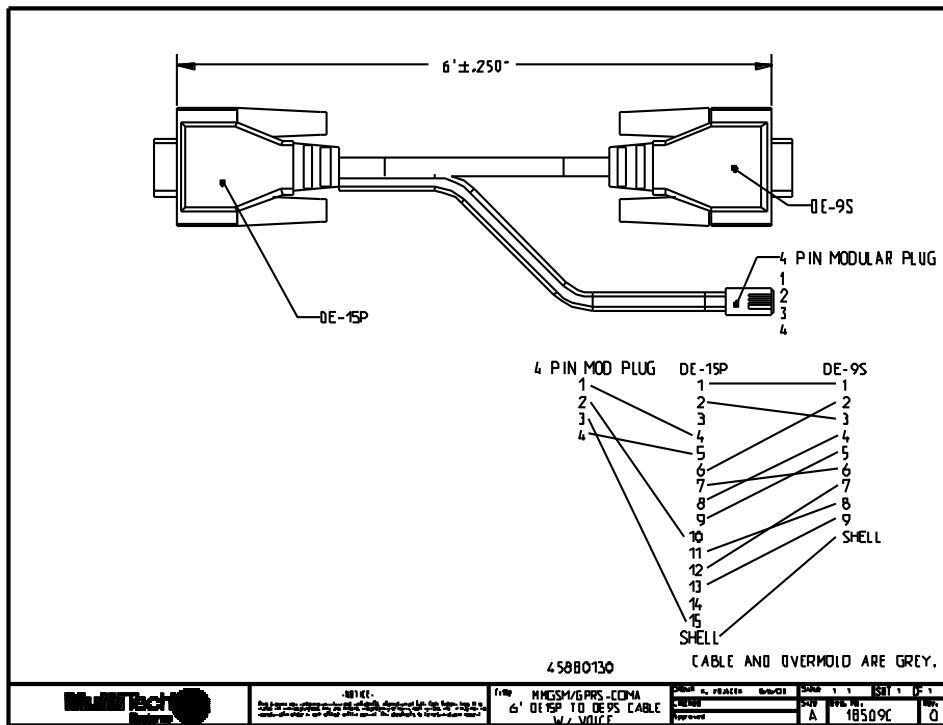

Fused DC Power Cable Dimensions

Changing the Fuse

The Fused DC power cable is provided when a single unit is purchased.

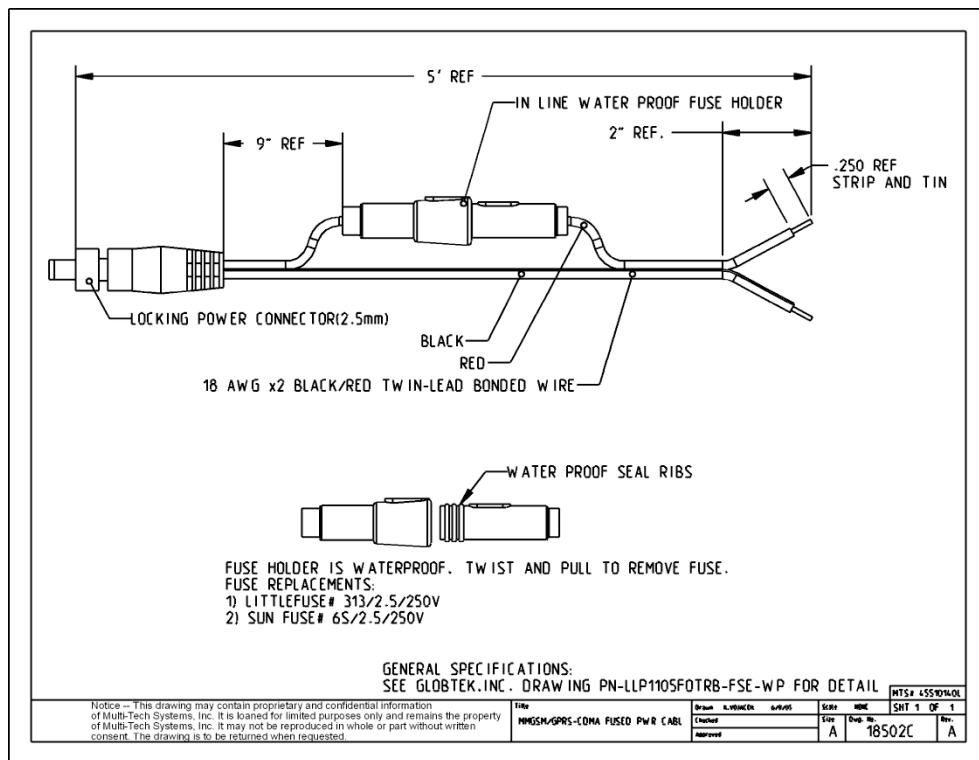

Appendix B – Regulatory and Compliance Information

47 CFR Part 15 Regulation Class B Devices

This equipment has been tested and found to comply with the limits for a **Class B** digital device, pursuant to part 15 of the FCC Rules. These limits are designed to provide reasonable protection against harmful interference in a residential installation. This equipment generates, uses, and can radiate radio frequency energy and, if not installed and used in accordance with the instructions, may cause harmful interference to radio communications. However, there is no guarantee that interference will not occur in a particular installation. If this equipment does cause harmful interference to radio or television reception, which can be determined by turning the equipment off and on, the user is encouraged to try to correct the interference by one or more of the following measures:

- Reorient or relocate the receiving antenna.
- Increase the separation between the equipment and receiver.
- Connect the equipment into an outlet on a circuit different from that to which the receiver is connected.
- Consult the dealer or an experienced radio/TV technician for help.

This device complies with Part 15 of the 47 CFR rules. Operation of this device is subject to the following conditions: (1) This device may not cause harmful interference, and (2) this device must accept any interference that may cause undesired operation.

Warning: Changes or modifications to this unit not expressly approved by the party responsible for compliance could void the user's authority to operate the equipment.

Industry Canada

This Class B digital apparatus meets all requirements of the Canadian Interference-Causing Equipment Regulations.

Cet appareil numérique de la classe B respecte toutes les exigences du Règlement Canadien sur le matériel brouilleur.

This device complies with Industry Canada RSS Appliance radio exempt from licensing. The operation is permitted for the following two conditions:

1. the device may not cause harmful interference, and
2. the user of the device must accept any interference suffered, even if the interference is likely to jeopardize the operation.

Le présent appareil est conforme aux CNR d'Industrie Canada applicables aux appareils radio exempts de licence. L'exploitation est autorisée aux deux conditions suivantes:

1. l'appareil ne doit pas produire de brouillage, et
2. l'utilisateur de l'appareil doit accepter tout brouillage radioélectrique subi, même si le brouillage est susceptible d'en compromettre le fonctionnement.

Waste Electrical and Electronic Equipment (WEEE)

The WEEE directive places an obligation on EU-based manufacturers, distributors, retailers and importers to take-back electronics products at the end of their useful life. A sister Directive, ROHS (Restriction of Hazardous Substances) complements the WEEE Directive by banning the presence of specific hazardous substances in the products at the design phase. The WEEE Directive covers all Multi-Tech products imported into the EU as of August 13, 2005. EU-based manufacturers, distributors, retailers and importers are obliged to finance the costs of recovery from municipal collection points, reuse, and recycling of specified percentages per the WEEE requirements.

Instructions for Disposal of WEEE by Users in the European Union

The symbol shown below is on the product or on its packaging, which indicates that this product must not be disposed of with other waste. Instead, it is the user's responsibility to dispose of their waste equipment by handing it over to a designated collection point for the recycling of waste electrical and electronic equipment. The separate collection and recycling of your waste equipment at the time of disposal will help to conserve natural resources and ensure that it is recycled in a manner that protects human health and the environment. For more information about where you can drop off your waste equipment for recycling, please contact your local city office, your household waste disposal service or where you purchased the product.



REACH Statement

Registration of Substances:

After careful review of the legislation and specifically the definition of an “article” as defined in EC Regulation 1907/2006, Title II, Chapter 1, Article 7.1(a)(b), it is our current view Multi-Tech Systems, Inc. products would be considered as “articles”. In light of the definition in § 7.1(b) which requires registration of an article only if it contains a regulated substance that “is intended to be released under normal or reasonable foreseeable conditions of use,” our analysis is that Multi-Tech Systems, Inc. products constitute nonregisterable articles for their intended and anticipated use.

Substances of Very High Concern (SVHC):

Per the candidate list of Substances of Very high Concern (SVHC) published October 28, 2008 we have reviewed these substances and certify the Multi-Tech Systems, Inc. products are compliant per the EU “REACH” requirements of less than 0.1% (w/w) for each substance.

If new SVHC candidates are published by the European Chemicals Agency, and relevant substances have been confirmed, that exceeds greater than 0.1% (w/w), Multi-Tech Systems, Inc. will provide updated compliance status.

Multi-Tech Systems, Inc. also declares it has been duly diligent in ensuring that the products supplied are compliant through a formalized process which includes collection and validation of materials declarations and selective materials analysis where appropriate. This data is controlled as a part of a formal quality system and will be made available upon request.

Restriction of the Use of Hazardous Substances (RoHS)



Multi-Tech Systems, Inc.
Certificate of Compliance
2011/65/EU

Multi-Tech Systems confirms that its embedded products comply with the chemical concentration limitations set forth in the directive 2011/65/EU of the European Parliament (Restriction of the use of certain Hazardous Substances in electrical and electronic equipment - RoHS)

These Multi-Tech products do not contain the following banned chemicals¹:

- Lead, [Pb] < 1000 PPM
- Mercury, [Hg] < 1000 PPM
- Hexavalent Chromium, [Cr+6] < 1000 PPM
- Cadmium, [Cd] < 100 PPM
- Polybrominated Biphenyl, [PBB] < 1000 PPM
- Polybrominated Diphenyl Ether, [PBDE] < 1000 PPM

Environmental considerations:

- Moisture Sensitivity Level (MSL) =1
- Maximum Soldering temperature = 260C (in SMT reflow oven)

¹Lead usage in some components is exempted by the following RoHS annex, therefore higher lead concentration would be found in some modules (>1000 PPM);

–Resistors containing lead in a glass or ceramic matrix compound.

Information on HS/TS Substances According to Chinese Standards

In accordance with China's Administrative Measures on the Control of Pollution Caused by Electronic Information Products (EIP) # 39, also known as China RoHS, the following information is provided regarding the names and concentration levels of Toxic Substances (TS) or Hazardous Substances (HS) which may be contained in Multi-Tech Systems Inc. products relative to the EIP standards set by China's Ministry of Information Industry (MII).

Name of the Component	Hazardous/Toxic Substance/Elements					
	Lead (PB)	Mercury (Hg)	Cadmium (CD)	Hexavalent Chromium (CR6+)	Polybrominated Biphenyl (PBB)	Polybrominated Diphenyl Ether (PBDE)
Printed Circuit Boards	O	O	O	O	O	O
Resistors	X	O	O	O	O	O
Capacitors	X	O	O	O	O	O
Ferrite Beads	O	O	O	O	O	O
Relays/Opticals	O	O	O	O	O	O
ICs	O	O	O	O	O	O
Diodes/ Transistors	O	O	O	O	O	O
Oscillators and Crystals	X	O	O	O	O	O
Regulator	O	O	O	O	O	O
Voltage Sensor	O	O	O	O	O	O
Transformer	O	O	O	O	O	O
Speaker	O	O	O	O	O	O
Connectors	O	O	O	O	O	O
LEDs	O	O	O	O	O	O
Screws, Nuts, and other Hardware	X	O	O	O	O	O
AC-DC Power Supplies	O	O	O	O	O	O
Software / Documentation CDs	O	O	O	O	O	O
Booklets and Paperwork	O	O	O	O	O	O
Chassis	O	O	O	O	O	O

- X** Represents that the concentration of such hazardous/toxic substance in all the units of homogeneous material of such component is higher than the SJ/Txxx-2006 Requirements for Concentration Limits.
- O** Represents that no such substances are used or that the concentration is within the aforementioned limits.

Information on HS/TS Substances According to Chinese Standards (in Chinese)

依照中国标准的有毒有害物质信息

根据中华人民共和国信息产业部 (MII) 制定的电子信息产品 (EIP) 标准—中华人民共和国《电子信息产品污染控制管理办法》(第 39 号), 也称作中国 RoHS, 下表列出了 Multi-Tech Systems, Inc. 产品中可能含有的有毒物质 (TS) 或有害物质 (HS) 的名称及含量水平方面的信息。

成分名称	有害/有毒物质/元素					
	铅 (PB)	汞 (Hg)	镉 (CD)	六价铬 (CR6+)	多溴联苯 (PBB)	多溴二苯醚 (PBDE)
印刷电路板	0	0	0	0	0	0
电阻器	X	0	0	0	0	0
电容器	X	0	0	0	0	0
铁氧体磁环	0	0	0	0	0	0
继电器/光学部件	0	0	0	0	0	0
IC	0	0	0	0	0	0
二极管/晶体管	0	0	0	0	0	0
振荡器和晶振	X	0	0	0	0	0
调节器	0	0	0	0	0	0
电压传感器	0	0	0	0	0	0
变压器	0	0	0	0	0	0
扬声器	0	0	0	0	0	0
连接器	0	0	0	0	0	0
LED	0	0	0	0	0	0
螺丝、螺母以及其它五金件	X	0	0	0	0	0
交流-直流电源	0	0	0	0	0	0
软件/文档 CD	0	0	0	0	0	0
手册和纸页	0	0	0	0	0	0
底盘	0	0	0	0	0	0

X 表示所有使用类似材料的设备中有害/有毒物质的含量水平高于 SJ/Txxx-2006 限量要求。

0 表示不含该物质或者该物质的含量水平在上述限量要求之内。