

# Multiple-Use-Mold Casting Processes

## Chapter 13

# 13.1 Introduction

- In expendable mold casting, a separate mold is produced for each casting
  - Low production rate for expendable mold casting
- If multiple-use molds are used, productivity can increase
- Most multiple-use molds are made from metal, so most molds are limited to low melting temperature metals and alloys

# 13.2 Permanent-Mold Casting

- Also known as gravity die casting
- Mold can be made from a variety of different materials
  - Gray cast iron, alloy cast iron, steel, bronze, or graphite
- Most molds are made in segments with hinges to allow rapid and accurate closing
  - Molds are preheated to improve properties
- Liquid metal flows through the mold cavity by gravity flow

# Permanent Mold Casting

- Process can be repeated immediately because the mold is still warm from the previous casting
- Most frequently cast metals
  - Aluminum, magnesium, zinc, lead, copper, and their alloys
  - If steel or iron is to be used, a graphite mold must be used

# Advantages of Permanent-Mold Casting

- Near- net shapes
- Little finish machining
- Reusable molds
- Good surface finish
- Consistent dimensions
- Directional solidification

# Disadvantages of Permanent Mold Casting

- Limited to lower melting temperature alloys
- High mold costs
  - Mold life is strongly tied to cost
  - Mold life is dependent on the following
    - Alloys being cast
    - Mold material
    - Pouring temperature
    - Mold temperature
    - Mold configuration
  - High production runs can validate high mold costs
- Molds are not permeable
- Limited mold complexity

# Permanent Mold Casting

**TABLE 13-1** Permanent-Mold Casting

*Process:* Mold cavities are machined into mating metal die blocks, which are then preheated and clamped together. Molten metal is then poured into the mold and enters the cavity by gravity flow.

After solidification, the mold is opened and the casting is removed.

*Advantages:* Good surface finish and dimensional accuracy; metal mold gives rapid cooling and fine-grain structure; multiple-use molds (up to 120,000 uses); metal cores or collapsible sand cores can be used.

*Limitations:* High initial mold cost; shape, size, and complexity are limited; yield rate rarely exceeds 60%, but runners and risers can be directly recycled; mold life is very limited with high-melting-point metals such as steel.

*Common metals:* Alloys of aluminum, magnesium, and copper are most frequently cast; irons and steels can be cast into graphite molds; alloys of lead, tin, and zinc are also cast.

*Size limits:* 100 grams to 75 kilograms (several ounces to 150 pounds).

*Thickness limits:* Minimum depends on material but generally greater than 3 mm ( $\frac{1}{8}$  in.); maximum thickness about 50 mm (2.0 in.).

*Geometric limits:* The need to extract the part from a rigid mold may limit certain geometric features. Uniform section thickness is desirable.

*Typical tolerances:* 0.4 mm for the first 2.5 cm (0.015 in. for the first inch) and 0.02 mm for each additional centimeter (0.002 in. for each additional inch); 0.25mm (0.01 in.) added if the dimension crosses a parting line.

*Draft allowance:* 2°–3°.

*Surface finish:* 2.5 to 7.5  $\mu\text{m}$  (100–250  $\mu\text{in.}$ ) rms.

# Low Pressure Permanent-Mold Casting

- Tilt-pour permanent-mold casting
  - Mold is rotated to force flow into the cavity
- Low pressure permanent-mold casting
  - Mold is upside down and connected to a crucible that contains the molten metal
  - Pressure difference induces upward flow
  - Metals are exceptionally clean because it is fed directly into the mold
  - Little or no turbulence during flow
  - Typical metals cast using low pressure process
    - Aluminum, magnesium, and copper



# Low-Pressure and Vacuum Permanent-Mold Casting

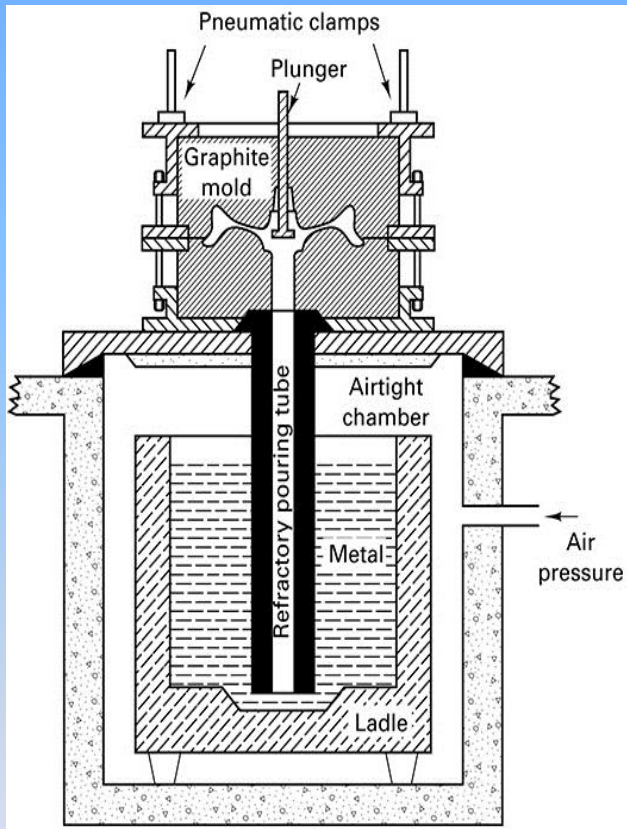

**Figure 13-2** Schematic of the low-pressure permanent-mold process. (Courtesy of Amsted Industries, Chicago, IL.)

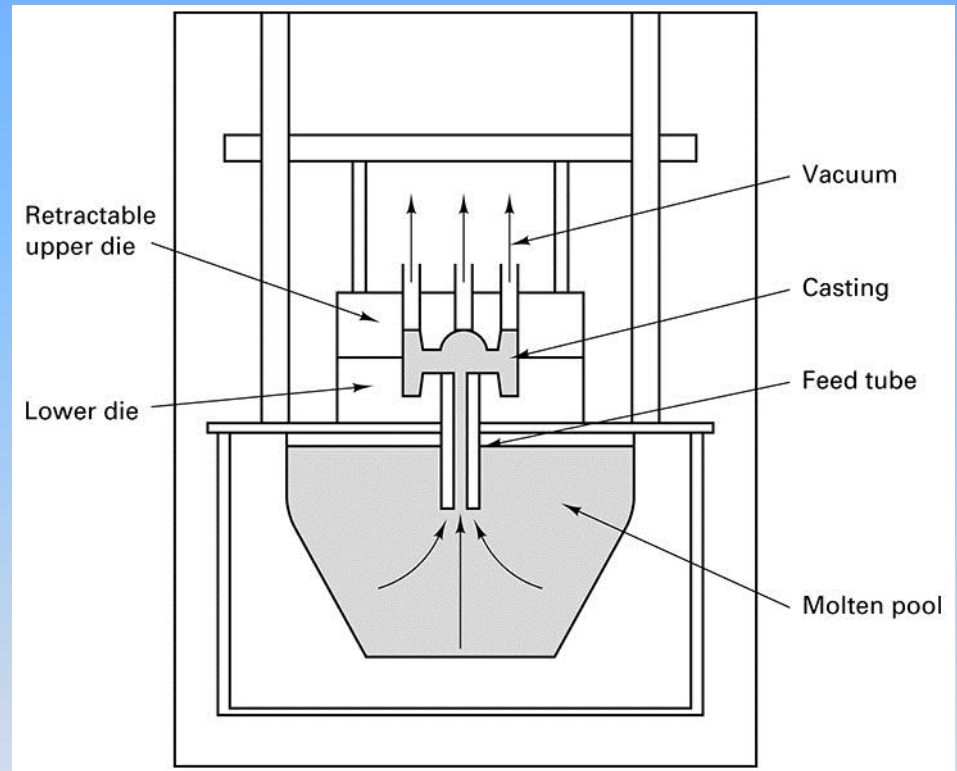

**Figure 13-3** Schematic illustration of vacuum permanent-mold casting. Note the similarities to the low-pressure process.

# Vacuum Permanent-Mold Casting

- Atmospheric pressure in the chamber forces the metal upward after the vacuum is drawn
- Thin-walled castings can be made
- Excellent surface quality
- Cleaner metals than low pressure
  - Lower dissolved gas content
- Better mechanical properties than low pressure casting

# 13.3 Die Casting

- Molten metal is forced into the mold under high pressure
- Held under high pressure during solidification
- Castings can have fine sections and complex details
- Long mold life
- Typical metals cast
  - Zinc, copper, magnesium, aluminum, and their alloys

# Advantages of Die Casting

- High production rates
- Good strength
- Intricate shapes
- Dimensional precision
- Excellent surface qualities
- Small-medium sized castings

# Die Modifications and Die Life

- Die complexity can be improved through the use of
  - Water cooled passages
  - Retractable cores
  - Moving pins to eject castings
- Die life
  - Limited by erosion and usage temperature
  - Surface cracking
  - Heat checking
  - Thermal fatigue

# Die-Casting Dies

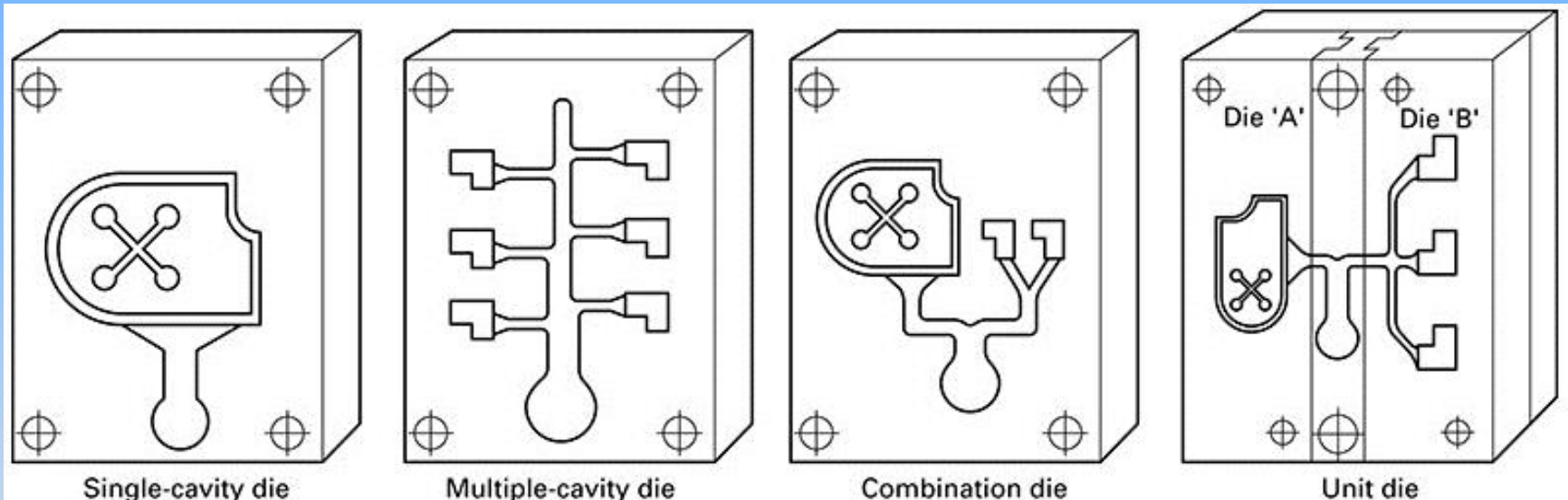

**Figure 13-4** Various types of die-casting dies. (Courtesy of American Die Casting Institute, Inc., Des Plaines, IL.)

# Basic Types of Die-Casting

- Hot chamber castings
  - Fast cycling times
  - No handling or transfer of molten metal
  - Used with zinc, tin, and lead-based alloys
- Heated-manifold direct injection die casting
  - Molten zinc is forced through a heated manifold
  - Next through heated mini-nozzles directly into the die cavity
  - Eliminates the need for sprues, gates and runners

# Basic Types of Die Casting

- Cold-chamber machines
  - Used for materials not suitable for hot chamber machines
  - Typical materials
    - Aluminum, magnesium, copper, and high-aluminum zinc
  - Longer operating cycle than hot-chamber
  - High productivity



# Summary of Die Casting

- Dies fill so fast with metal that there is little time for the air in the runner and die to escape
- Molds offer no permeability
  - Air can become trapped and cause defects
- Risers are not used because of the high pressures used
- Sand cores can not be used due to high pressures
  - Cast-in inserts can be used
- High production rates
- Little post casting finishing necessary

# Die Casting

**TABLE 13-2** Die Casting

*Process:* Molten metal is injected into closed metal dies under pressures ranging from 10 to 175 MPa (1500–25,000 psi). Pressure is maintained during solidification, after which the dies separate and the casting is ejected along with its attached sprues and runners. Cores must be simple and retractable and take the form of moving metal segments.

*Advantages:* Extremely smooth surfaces and excellent dimensional accuracy; rapid production rate; product tensile strengths as high as 415 Mpa (60 ksi).

*Limitations:* High initial die cost; limited to high-fluidity nonferrous metals; part size is limited; porosity may be a problem; some scrap in sprues, runners, and flash, but this can be directly recycled.

*Common metals:* Alloys of aluminum, zinc, magnesium, and lead; also possible with alloys of copper and tin.

*Size limits:* Less than 30 grams (1 oz) up through about 7 kg (15 lb) most common.

*Thickness limits:* As thin as 0.75 mm (0.03 in.), but generally less than 13 mm ( $\frac{1}{2}$  in.).

*Typical tolerances:* Varies with metal being cast; typically 0.1mm for the first 2.5 cm (0.005 in. for the first inch) and 0.02 mm for each additional centimeter (0.002 in. for each additional inch).

*Draft allowances:* 1°–3°.

*Surface finish:* 1–2.5  $\mu\text{m}$ (40–100  $\mu\text{in.}$ ) rms.

---

# Die Casting

**Figure 13-5** (Below) Principal components of a hot-chamber die-casting machine. (Adapted from Metals Handbook, 9<sup>th</sup> ed., Vol. 15, p. 287, ASM International, Metals Park, OH.)

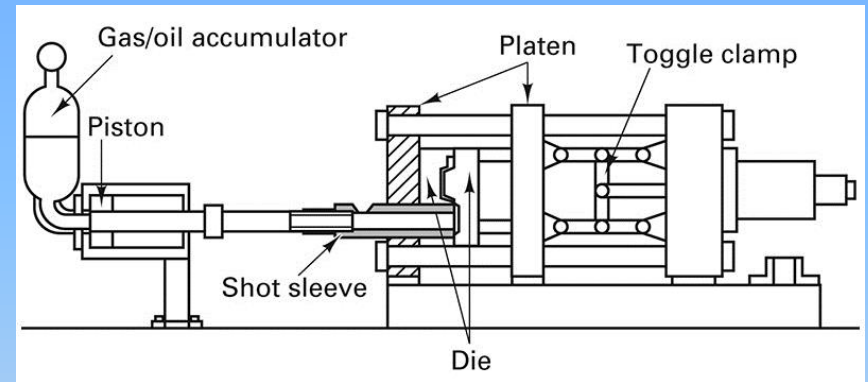
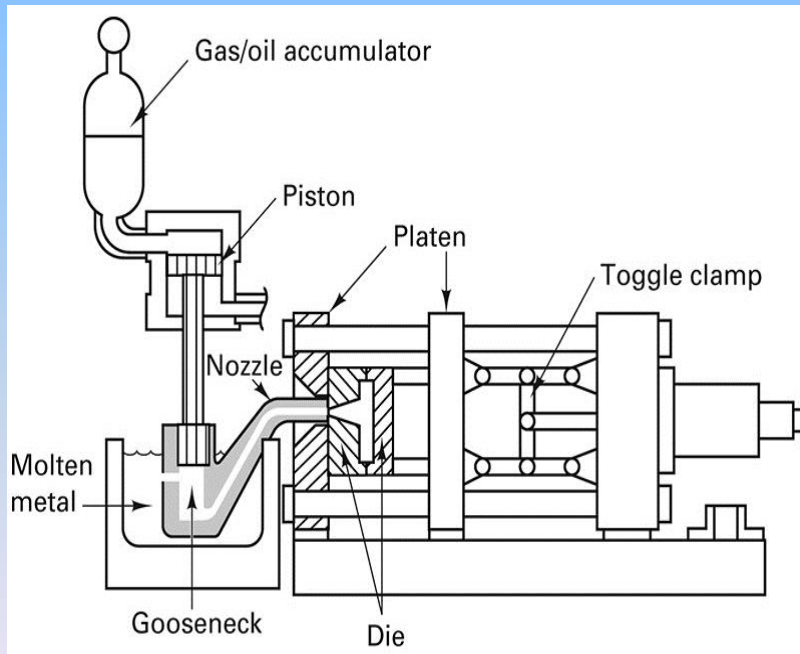

**Figure 13-6** (Above) Principal components of a cold-chamber die-casting machine. (Adapted from Metals Handbook, 9<sup>th</sup> ed., Vol 15, p. 287, ASM International, Metals Park, OH.)

# 13.4 Squeeze Casting and Semisolid Casting

- Advantages
  - High production
  - Thin-walled parts
  - Good surface finish
  - Dimensional precision
  - Good mechanical properties
- Squeeze Casting
  - Large gate areas and slow metal velocities to avoid turbulence
  - Solidification occurs under high pressure
  - Intricate shapes with good mechanical properties
  - Reduced gas and shrinkage porosity

# Rheocasting and Thixocasting

- Rheocasting
  - Molten metal is cooled to semisolid
  - Metal is stirred to break up dendrites
- Thixocasting
  - No handling of molten metal
  - Metal is stirred as in rheocasting and produced into blocks or bars
  - Metal is then reheated to semisolid and can be handled as a solid but processed as a liquid
  - Injection system used is similar to the one used in plastic injection molding

# Die Cast Materials

**TABLE 13-3** Key Properties of the Four Major Families of Die-Cast Metal

Metal	Key Properties
Aluminum	Lowest cost per unit volume; second lightest to magnesium; highest rigidity; good machinability, electrical conductivity, and heat-transfer characteristics.
Magnesium	Lowest density, faster production than aluminum since hot-chamber cast, highest strength-to-weight ratio, good vibration damping, best machinability, can provide electromagnetic shielding.
Zinc	Attractive for small parts; tooling lasts 3–5 times longer than for aluminum; heaviest of the die-castable metals but can be cast with thin walls for possible weight savings; good impact strength, machinability, electrical conductivity, and thermal conductivity.
Zinc–Aluminum	Highest yield and tensile strength, lighter than conventional zinc alloys, good machinability.

# Die Cast Materials

**TABLE 13-4** Comparison of Properties (Die-Cast Metals vs. Other Engineering Materials)

Material	Yield Strength		Tensile Strength		Elastic Modulus	
	MPa	ksi	MPa	ksi	GPa	10 <sup>6</sup> psi
Die-cast alloys						
360 aluminum	170	25	300	44	71	10.3
380 aluminum	160	23	320	46	71	10.3
AZ91D magnesium	160	23	230	34	45	6.5
Zamak 3 zinc (AG40A)	221	32	283	41	—	—
Zamak 5 zinc (AC41A)	269	39	328	48	—	—
ZA-8 (zinc–aluminum)	283–296	41–43	365–386	53–56	85	12.4
ZA-27 (zinc–aluminum)	359–379	52–55	407–441	59–64	78	11.3
Other metals						
Steel sheet	172–241	25–35	276	40	203	29.5
HSLA steel sheet	414	60	414	60	203	29.5
Powdered iron	483	70	—	—	120–134	17.5–19.5
Plastics						
ABS	—	—	55	8	7	1.0
Polycarbonate	—	—	62	9	7	1.0
Nylon 6 <sup>a</sup>	—	—	152	22	10	1.5
PET <sup>a</sup>	—	—	145	21	14	2.0

<sup>a</sup>30% glass reinforced.

# 13.5 Centrifugal Casting

- Inertial forces due to spinning distribute the molten metal into the mold cavity
- True centrifugal casting
  - Dry-sand, graphite or metal mold can be rotated horizontally or vertically
  - Exterior profile of final product is normally round
    - Gun barrels, pipes, tubes
  - Interior of the casting is round or cylindrical
  - If the mold is rotated vertically, the inner surfaces will be parabolic



# Centrifugal Casting

- Specialized equipment
- Expensive for large castings
- Long service life
- No sprues, gates, or risers

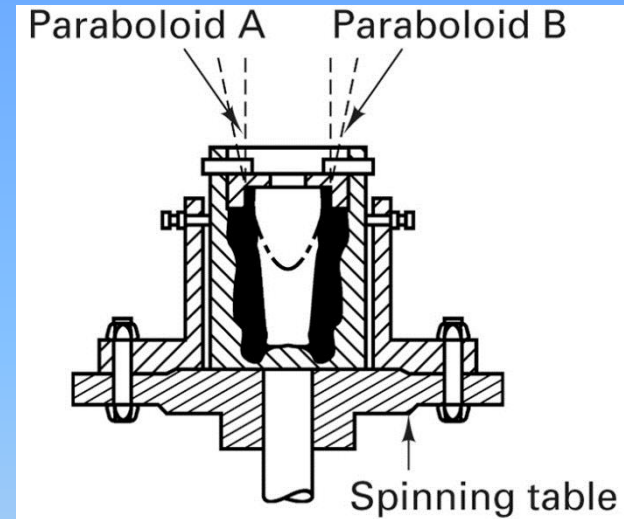

**Figure 13-9** (Above) Vertical centrifugal casting, showing the effect of rotational speed on the shape of the inner surface. Paraboloid A results from fast spinning whereas slower spinning will produce paraboloid B.

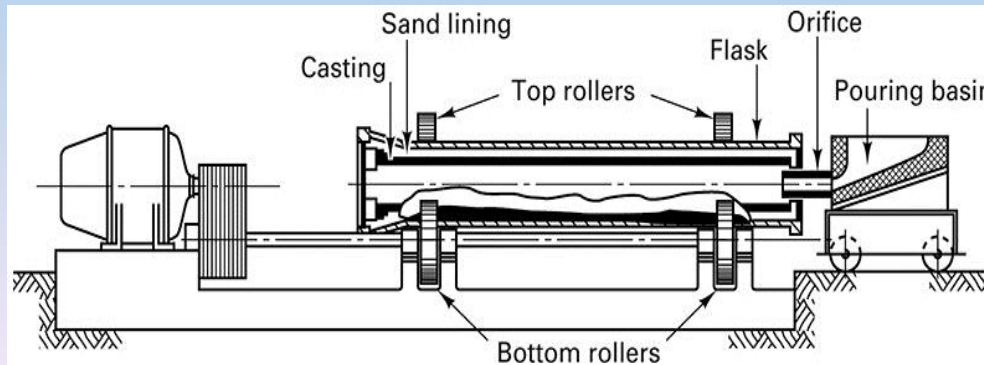

**Figure 13-8** (Left) Schematic representation of a horizontal centrifugal casting machine. (Courtesy of American Cast Iron Pipe Company, Birmingham, AL.)

# Centrifugal Casting

- Semicentrifugal casting
  - Several molds may be stacked on top of one another
  - Share a common basin and sprue
  - Used for gear blanks, pulley sheaves, wheels, impellers, etc.
- Centrifuging
  - Uses centrifugal acceleration to force metal into mold cavities that are offset from the axis of rotation

# Centrifugal Casting

**TABLE 13-5** Centrifugal Casting

*Process:* Molten metal is introduced into a rotating sand, metal, or graphite mold and held against the mold wall by centrifugal force until it is solidified.

*Advantages:* Can produce a wide range of cylindrical parts, including ones of large size; good dimensional accuracy, soundness, and cleanliness.

*Limitations:* Shape is limited; spinning equipment can be expensive.

*Common metals:* Iron; steel; stainless steel; and alloys of aluminum, copper, and nickel.

*Size limits:* Up to 3 m (10 ft) in diameter and 15 m (50 ft) in length.

*Thickness limits:* Wall thickness 2.5 to 125 mm (0.1–5 in.).

*Typical tolerances:* O.D. to within 2.5 mm (0.1 in.); I.D. to about 4 mm (0.15 in.).

*Draft allowance:* 10 mm/m ( $\frac{1}{8}$  in./ft).

*Surface finish:* 2.5–12.5  $\mu\text{m}$  (100–500  $\mu\text{in.}$ ) rms.

**Figure 13-10** Electrical products (collector rings, slip rings, and rotor end rings) that have been centrifugally cast from aluminum and copper. (Courtesy of The Electric Materials Company, North East, PA.)

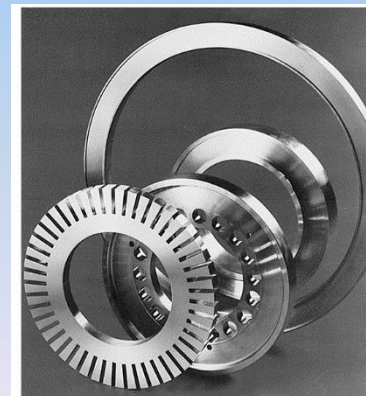

# Centrifuging

**Figure 13-11** Schematic of a semicentrifugal casting process.

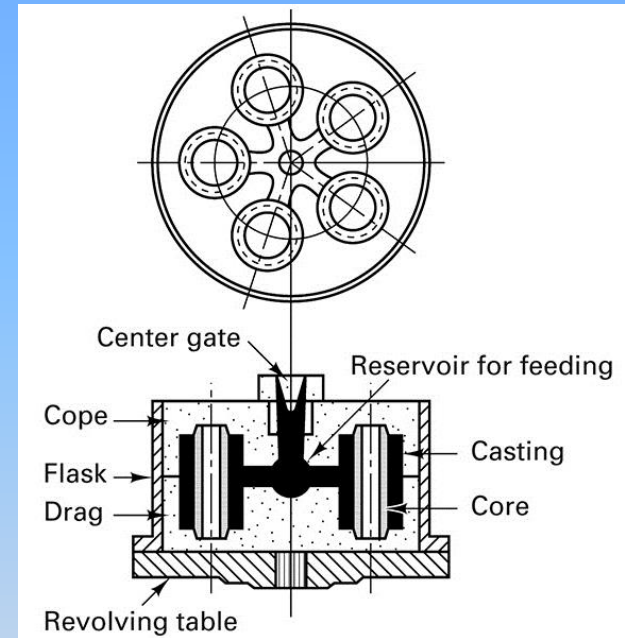
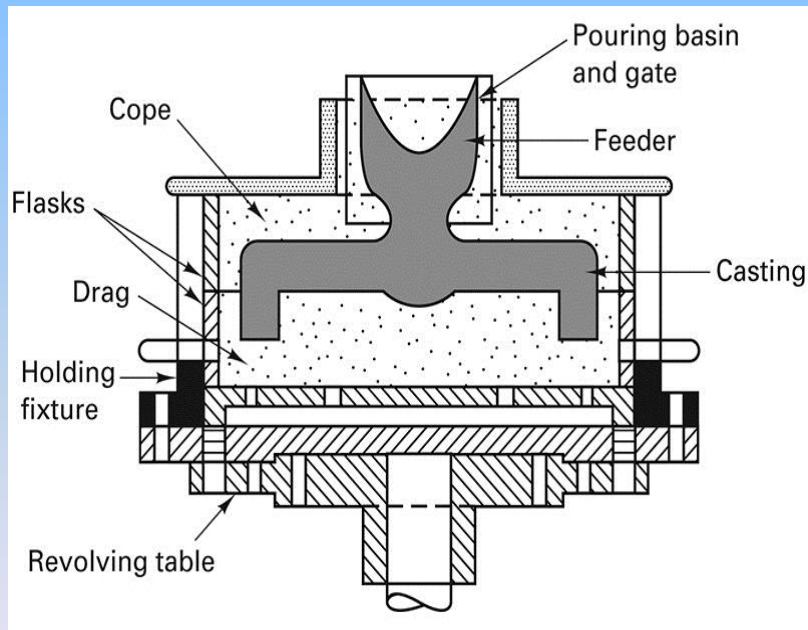

**Figure 13-12** (Above) Schematic of a centrifuging process. Metal is poured into the central pouring sprue and spun into the various mold cavities. (Courtesy of American Cast Iron Pipe Company, Birmingham, AL.)

# 13.6 Continuous Casting

- Used for the solidification of basic shapes for feedstock
- Can be used to produce long lengths of complex cross sections

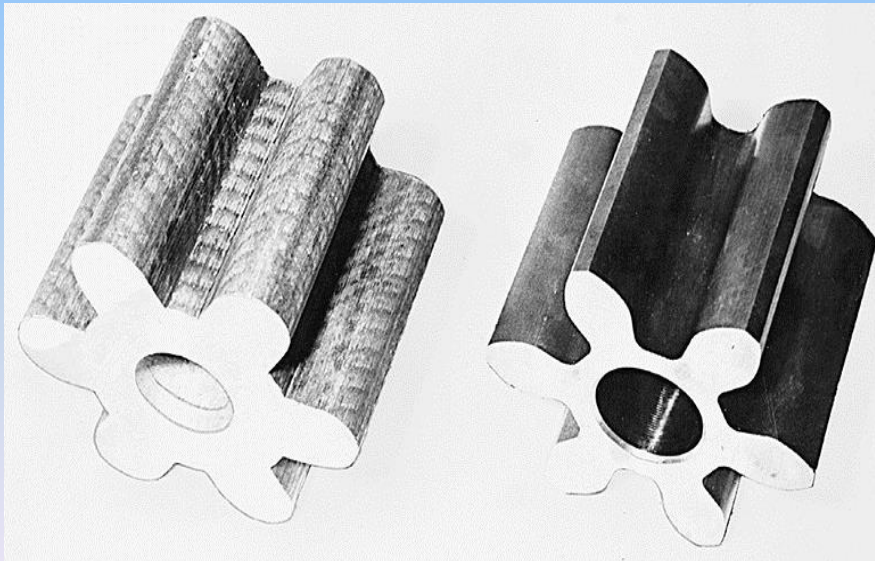

**Figure 13-13** Gear produced by continuous casting. (Left) As-cast material; (right) after machining. (Courtesy of ASARCO, Tucson, AZ.)

# 13.7 Melting

- Selection of melting method is based on several factors
  - Temperature needed to melt and superheat the metal
  - Alloy being melted
  - Desired melting rate and quantity
  - Desired quality of metal
  - Availability and cost of fuels
  - Variety of metals or alloys to be melted
  - Batch or continuous
  - Required level of emission control
  - Capital and operating costs

# Cupolas

- Cupola- refractory-lined, vertical steel shell
  - Alternating layers of carbon, iron, limestone, and alloy additions
  - Melted under forced air
- Simple and economical
- Melting rate can be increased by using hot-blast cupolas, oxygen-enriched blasts, or plasma torches

# Types of Furnaces

- Indirect Fuel-Fired Furnace
  - Crucibles or holding pots are heated externally which in turn heats the metal
  - Low capital and operating costs
- Direct Fuel-Fired Furnace
  - Similar to small open-hearth furnaces
  - Flame passes directly over metal

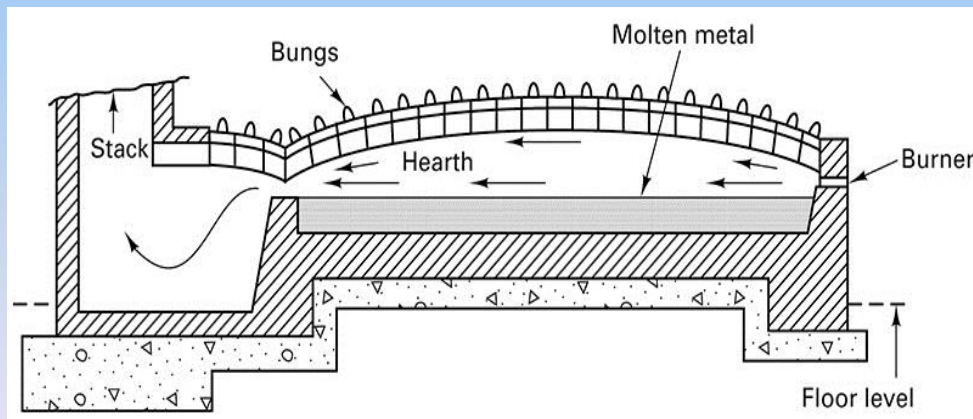

**Figure 13-14** Cross section of a direct fuel-fired furnace. Hot combustion gases pass across the surface of a molten metal pool.



# Arc Furnaces

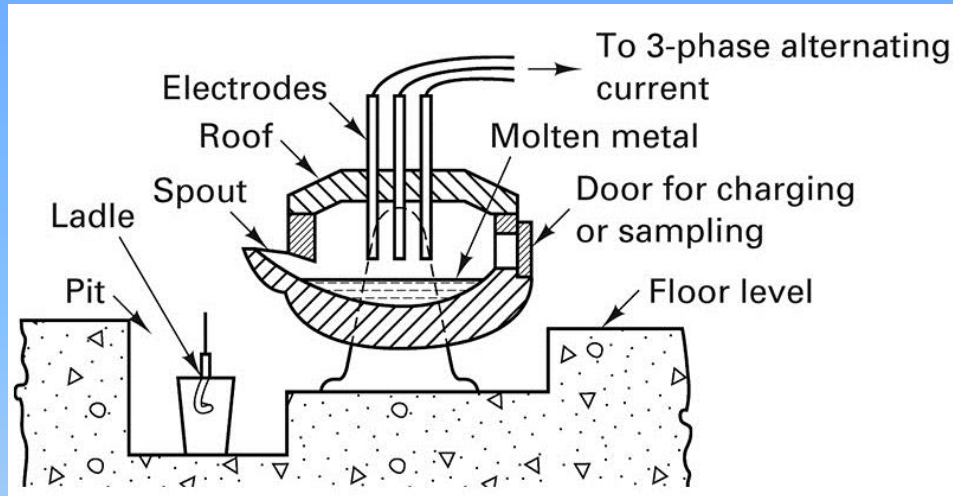

Figure 13-15 Schematic diagram of a three-phase electric-arc furnace.

- Preferred method for most factories
- Rapid melting rates
- Ability to hold molten metal for any period of time
- Greater ease of incorporating pollution control equipment

# Induction Furnaces

- Rapid melting rates
- Two basic types of induction furnaces
  - High-frequency (coreless)
    - Contains a crucible surrounded by a water-cooled coil of copper tubing
    - High-frequency electrical current induces an alternating magnetic field
    - The magnetic field, in turn, induces a current in metal being melted
  - Low-frequency (channel-type)
    - Small channel is surrounded by the primary coil and a secondary coil is formed by a loop or channel of molten metal

# Induction Furnaces

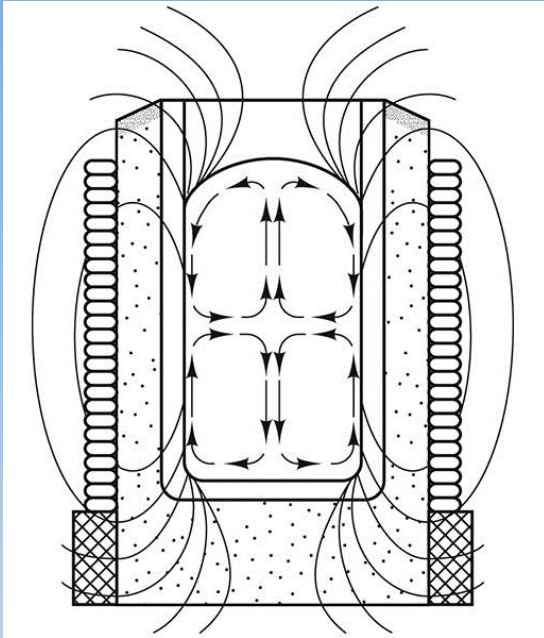

**Figure 13-17** (Above) Schematic showing the basic principle of a coreless induction furnace.

**Figure 13-18** (Below) Cross section showing the principle of the low-frequency or channel-type induction furnace.

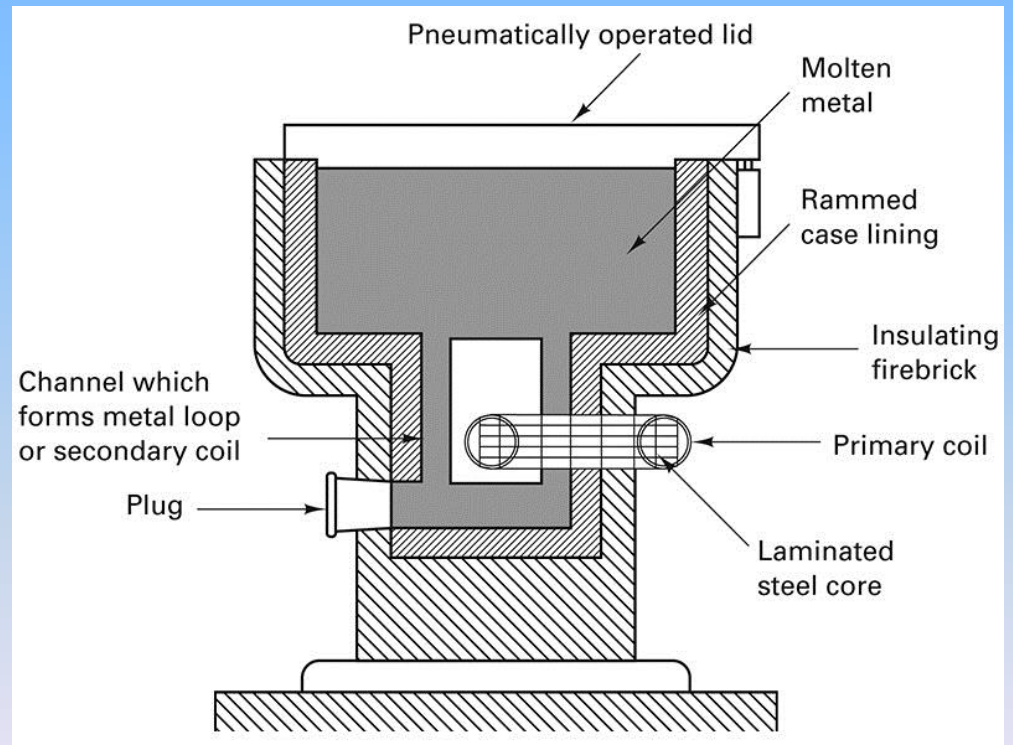

# 13.8 Pouring Practice

- Ladles are used to transfer the metal from the melting furnace to the mold
- Concerns during pouring
  - Maintain proper metal temperature
  - Ensure that only high-quality metal is transferred
- Pouring may be automated in high-volume, mass-production foundries

# Automatic Pouring

**Figure 13-19** Automatic pouring of molds on a conveyor line. (Courtesy of Roberts Sinto Corporation, Lansing, MI.)

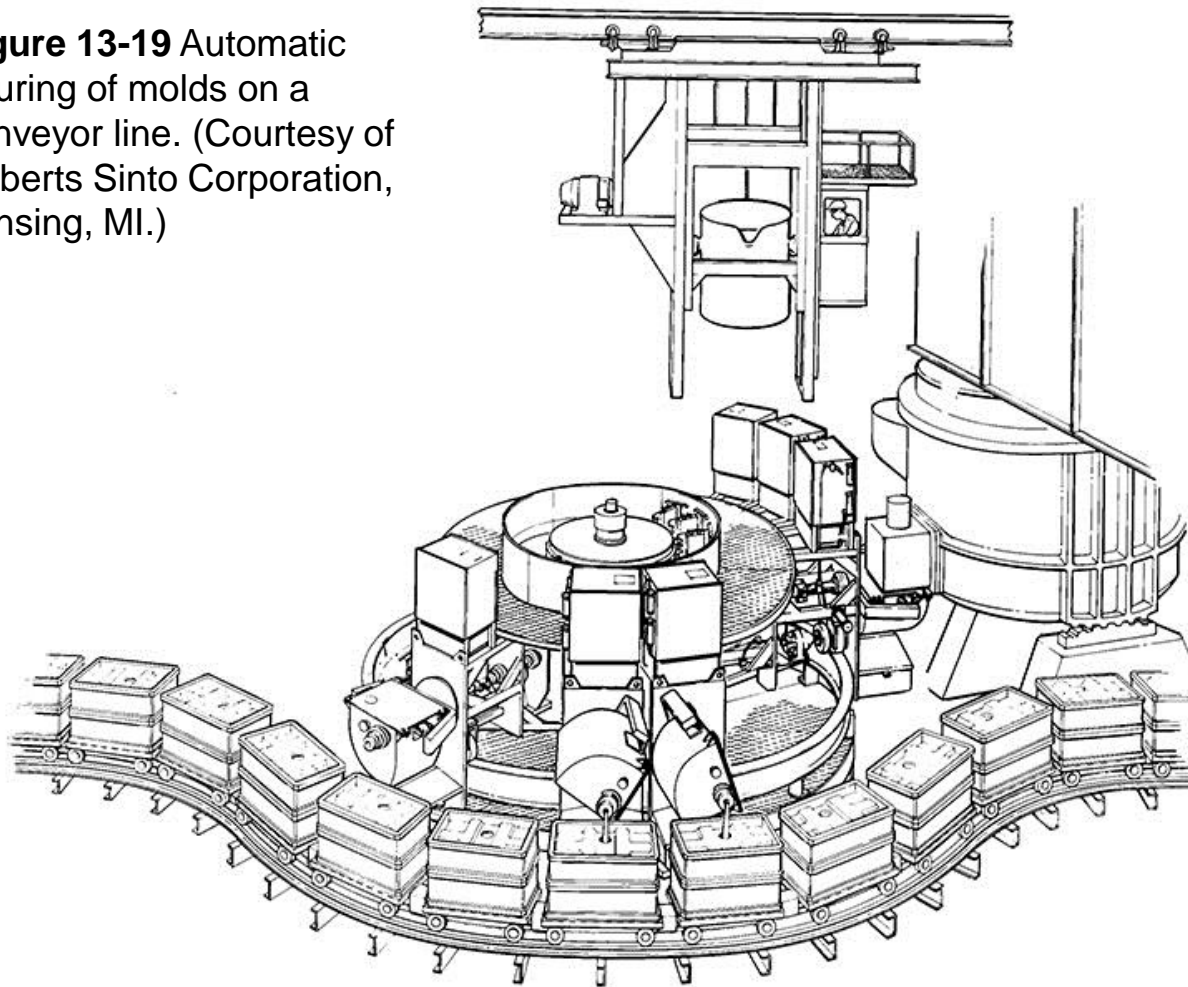

# 13.9 Cleaning, Finishing, and Heat Treating of Castings

- Post-casting operations
  - Removing cores
  - Removing gates and risers
  - Removing fins, flash, and rough surface spots
  - Cleaning the surface
  - Repairing any defects
- Cleaning and finishing may be expensive, so processes should be selected that minimize necessary operations

# Cleaning and Finishing

- Sand cores may be removed by mechanical shaking or chemically dissolved
- Flash may be removed by being tumbled in barrels containing abrasive materials
- Manual finishing
  - Pneumatic chisels, grinders, blast hoses
- Porosity at surfaces may be filled with resins (impregnation)
- Pores may also be filled with lower-melting point metals (infiltration)

# Heat Treatment and Inspection of Casting

- Heat treatments alter properties while maintaining shape
- Full anneals reduce hardness and brittleness of rapidly cooled castings
  - Reduce internal stresses
- Nonferrous castings may be heat treated to provide chemical homogenization or stress relief
- Prepares materials for further finishing operations



# 13.10 Automation in Foundries

- Most manufacturing operations may be performed by robots
  - Dry mold, coat cores, vent molds, clean or lubricate dies
  - Plasma torches
  - Grinding and blasting
  - Investment casting
  - Lost foam process
- Casting can be dangerous for workers; by automating these processes, safety is increased

# 13.11 Process Selection

- Each casting process has advantages and disadvantages
- Typical requirements
  - Size, complexity, dimensional precision, surface finish, quantity, rate of production
  - Costs for materials (dies, equipment, and metal)

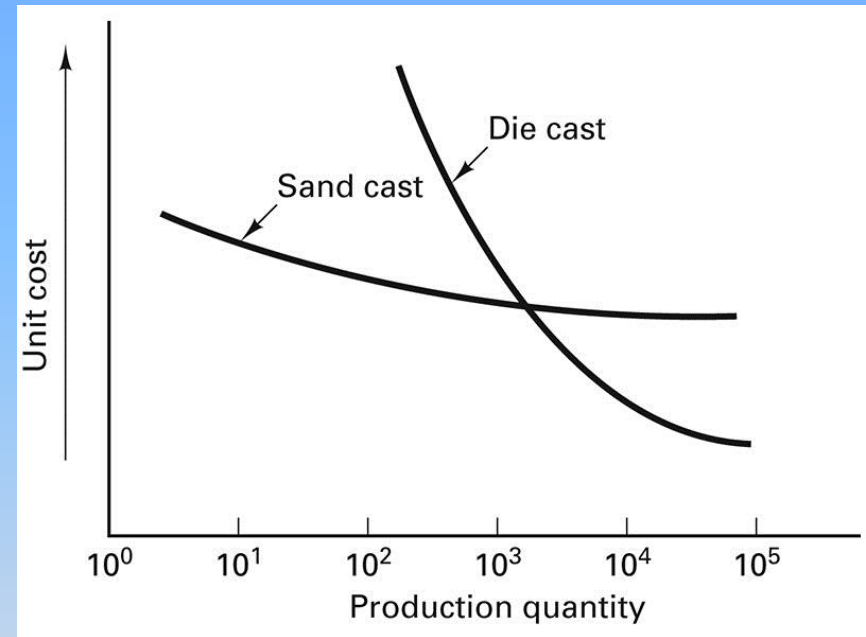

**Figure 13-20** Typical unit cost of castings comparing sand casting and die casting. Note how the large cost of a die-casting die diminishes as it is spread over a larger quantity of parts.

**TABLE 13-6** Comparison of Casting Processes

Property or Characteristic	Green-Sand Casting	Chemically Bonded Sand (Shell, Sodium Silicate, Air-Set)	Ceramic Mold and Investment Casting	Permanent-Mold Casting	Die Casting
Relative cost for small quantity	Lowest	Medium high	Medium	High	Highest
Relative cost for large quantity	Low	Medium high	Highest	Low	Lowest
Thinnest section (inches)	$\frac{1}{10}$	$\frac{1}{10}$	$\frac{1}{16}$	$\frac{1}{8}$	$\frac{1}{32}$
Dimensional precision (+/- in inches)	0.01–0.03	0.005–0.015	0.01–0.02	0.01–0.05	0.001–0.015
Relative surface finish	Fair to good	Good	Very good	Good	Best
Ease of casting complex shape	Fair to good	Good	Best	Fair	Good
Ease of changing design while in production	Best	Fair	Fair	Poor	Poorest
Castable metals	Unlimited	Unlimited	Unlimited	Low-melting-point metals	Low-melting-point metals

# Summary

- Variety of casting processes
- Each has its own set of characteristics and benefits
- Care should be taken in properly selecting a casting process to minimize cost while maximizing qualities of the finished product
- Most casting processes may be automated, but the process selected determines the quality of the finished product