

# Murphy LVL Technical Design Guide

## 2.0E, 2.1E, 2.2E



**MURPHY**  
Engineered Wood

# Murphy Company



For over 100 years, Murphy Company has manufactured wood products for discerning customers who demand quality.

From green and dry softwood veneer (White City and Foster, OR and Elma, WA), to softwood plywood (Rogue River, OR), Hardwood Plywood (Eugene, OR), or Engineered Douglas-fir LVL (Sutherlin, OR), we understand our customers' needs and provide solutions for demanding market conditions.

Controlling the entire process, from “log to finished product,” allows us to customize your product at a competitive price.

## Douglas fir LVL

Providing the superior performance and durability of engineered wood, Murphy Company LVL is perfectly suited to spans bearing heavy loads and multi-span applications. Common problems associated with lumber sizes – like decreased dimensional stability and uniformity – do not apply to our LVL, which utilizes ultrasonically tested and graded Douglas fir veneer.

## Engineered for Quality

Checking is minimized because Murphy Company LVL is cured in a controlled process in which water-proof adhesives boost stability and reduce warps and twists. All products are machine-ripped to generate uniform size and rigid, flat surfaces with inherently superior nail-holding characteristics.

We are confident that our products will provide our customers with consistent high performance when handled and installed in accordance with our installation instructions.

Tested for strength and engineered for quality, Murphy Company LVL represents our ongoing commitment to unsurpassed performance and service.

Murphy Company LVL is third-party inspected and audited for quality by APA (The Engineered Wood Association), a leading industry quality assurance organization.



General notes for this product guide:

1. All tables assume dry conditions. Calculations are based on NDS and IBC and ICC-ESR#2913.
2. Lateral support of the compression edge of all beams must be provided at 24" on center.
3. Application tables include live load reductions applied in accordance with 2018 IBC.
4. Tables apply to Dead, Floor Live, Roof Live and Snow loads. Lateral loads must be considered by the building designer.
5. This design manual is intended to be used for preliminary design purposes; a complete structural analysis should be performed by a design professional.
6. Beams that are 1-3/4" x 16" and deeper require multiple plies.

# LVL Design Properties

## Allowable Design Properties – 1 3/4"

Depth	Max. Vertical Shear (lbs)			Max. Bending Moment (ft-lbs)			EI (x 10 <sup>6</sup> lbs-in)	Weight (plf)
	100%	115%	125%	100%	115%	125%		
5 1/2	1861	2140	2326	2623	3016	3279	49	2.51
7 1/4	2453	2821	3066	4336	4987	5421	111	3.30
9 1/4	3130	3599	3912	6756	7770	8445	231	4.22
9 1/2	3214	3696	4018	7092	8156	8865	250	4.33
11 1/4	3806	4377	4758	9648	11095	12059	415	5.13
11 7/8	4018	4620	5022	10645	12242	13306	488	5.41
14	4737	5447	5921	14364	16519	17955	800	6.38
16	5413	6225	6767	18315	21063	22894	1195	7.29
18	6090	7004	7613	22694	26098	28368	1701	8.19
20	6767	7782	8458	27491	31615	34364	2333	9.12
22	7443	8560	9304	32699	37603	40873	3106	10.03
24	8120	9338	10150	38309	44056	47877	4032	10.94

## Allowable Design Properties – 3 1/2"

Depth	Max. Vertical Shear (lbs)			Max. Bending Moment (ft-lbs)			EI (x 10 <sup>6</sup> lbs-in)	Weight (plf)
	100%	115%	125%	100%	115%	125%		
5 1/2	3722	4280	4652	5246	6033	6557	97	5.01
7 1/4	4906	5642	6132	8673	9974	10841	222	6.61
9 1/4	6259	7198	7824	13512	15539	16890	462	8.43
9 1/2	6428	7393	8035	14184	16312	17730	500	8.66
11 1/4	7613	8754	9516	19295	22189	24119	831	10.25
11 7/8	8035	9241	10044	21290	24484	26613	977	10.82
14	9473	10894	11842	28728	33037	35910	1601	12.76
16	10827	12451	13533	36631	42126	45789	2389	14.58
18	12180	14007	15225	45388	52197	56736	3402	16.41
20	13534	15564	16916	54982	63230	68728	4666	18.23
22	14886	17120	18608	65398	75206	81746	6212	20.05
24	16240	18676	20300	76618	88112	95774	8064	21.87

## Allowable Design Properties – 5 1/4"

Depth	Max. Vertical Shear (lbs)			Max. Bending Moment (ft-lbs)			EI (x 10 <sup>6</sup> lbs-in)	Weight (plf)
	100%	115%	125%	100%	115%	125%		
9 1/4	9389	10797	11736	20268	23309	25335	693	12.65
9 1/2	9643	11089	12053	21276	24468	26595	750	12.99
11 1/4	11419	13132	14273	28943	33284	36178	1246	15.38
11 7/8	12053	13861	15066	31936	36726	39919	1465	16.24
14	14210	16342	17763	43092	49556	53865	2401	19.14
16	16240	18676	20300	54946	63188	68683	3584	21.88
18	18270	21011	22838	68083	78295	85103	5103	24.61

## Allowable Design Properties – 7"

Depth	Max. Vertical Shear (lbs)			Max. Bending Moment (ft-lbs)			EI (x 10 <sup>6</sup> lbs-in)	Weight (plf)
	100%	115%	125%	100%	115%	125%		
9 1/4	12518	14396	15648	27024	31078	33781	923	16.86
9 1/2	12857	14785	16071	28369	32624	35461	1000	17.32
11 1/4	15225	17509	19031	38590	44379	48238	1661	20.51
11 7/8	16071	18481	20089	42581	48968	53226	1954	21.65
14	18947	21789	23683	57456	66074	71820	3201	25.52
16	21653	24901	27067	73262	84251	91577	4779	29.17
18	24360	28014	30450	90777	104394	113471	6804	32.81

### 2.0E, 2.1E, 2.2E LVL Allowable Design Stresses

Bending  $F_b = 3100$  psi (Adjust  $F_b$  value by a factor of  $(12/d)^{0.18}$  where  $d =$  depth.)

Horizontal Shear  $F_v = 290$  psi

Modulus of Elasticity  $E = 2.0, 2.1E, 2.2E$

Compression Perpendicular to Grain  $F_c = 750$  psi

Compression Parallel to Grain  $f_c = 3,200$  psi

## 2.0E, 2.1E, 2.2E LVL Floor Beams

### Application Table – 2.0E, 2.1E, 2.2E Floor Beams - 1 3/4" Width

Width of Building	Beam Span									
	11'	12'	13'	14'	15'	16'	17'	18'	19'	20'
24'	2 - 11 1/4	2 - 11 1/4	2 - 11 7/8	2 - 14	2 - 14	2 - 16	2 - 16	2 - 16	2 - 18	2 - 18
	3 - 9 1/4	3 - 9 1/2	3 - 11 1/4	3 - 11 1/4	3 - 11 7/8	3 - 14	3 - 14	3 - 14	3 - 16	3 - 16
28'	2 - 11 1/4	2 - 11 1/4	2 - 14	2 - 14	2 - 14	2 - 16	2 - 16	2 - 18	2 - 18*	2 - 18*
	3 - 9 1/4	3 - 11 1/4	3 - 11 1/4	3 - 11 7/8	3 - 14	3 - 14	3 - 14	3 - 16	3 - 16	3 - 16
32'	2 - 11 1/4	2 - 11 7/8	2 - 14	2 - 14	2 - 16	2 - 16*	2 - 16*	2 - 18*	2 - 18*	3 - 18
	3 - 9 1/2	3 - 11 1/4	3 - 11 1/4	3 - 11 7/8	3 - 14	3 - 14	3 - 14	3 - 16	3 - 16	4 - 16
36'	2 - 11 1/4	2 - 14	2 - 14	2 - 14	2 - 16*	2 - 16*	2 - 18*	2 - 18*	3 - 16	3 - 18
	3 - 11 1/4	3 - 11 1/4	3 - 11 7/8	3 - 14	3 - 14	3 - 14	3 - 16	3 - 16	4 - 16	4 - 16
40'	2 - 11 7/8	2 - 14	2 - 14*	2 - 16*	2 - 16*	2 - 18*	2 - 18*	3 - 16	3 - 18	3 - 18
	3 - 11 1/4	3 - 11 1/4	3 - 11 7/8	3 - 14	3 - 14	3 - 14	3 - 16	4 - 14	4 - 16	4 - 16

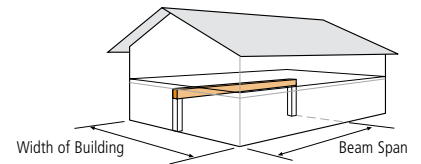

#### Notes

- Table indicates the number of 1 3/4" wide LVL plies to be used for the given application.
- Span is based on the more restrictive of simple continuous beam span. Ratio of short span to long span should be greater than 0.4.
- Beam must be centered in building if floor joists are continuous over the top. Beam may be located off-center and "width of building" may be taken as 80% of the actual width if joists hang from beam and are simple span.
- Max beam deflection =  $L/360$  LL  $L/240$  TL.
- 40 psf floor LL, 12 psf floor DL.
- Min. 3" bearing each end, 7 1/2" interior bearing length (\*indicates 4 1/2" end bearing and/or 11 1/4" interior bearing length).



# Garage Door Headers

These tables provide two selections for supporting roof loads over standard garage-door openings in various conditions.

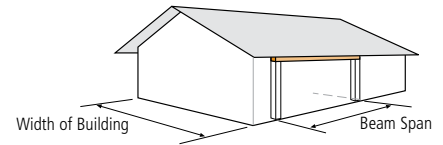

**1-Story Application Table - 2.0E, 2.1E, 2.2E Garage Door Headers - 1<sup>3</sup>/<sub>4</sub>" Width**

Width of Building	Snow 115%									Non-Snow 125%								
	25 psf LL + 20 psf DL			30 psf LL + 20 psf DL			40 psf LL + 20 psf DL			20 psf LL + 15 psf DL			20 psf LL + 20 psf DL			20 psf LL + 25 psf DL		
	9' 3"	16' 3"	18' 3"	9' 3"	16' 3"	18' 3"	9' 3"	16' 3"	18' 3"	9' 3"	16' 3"	18' 3"	9' 3"	16' 3"	18' 3"	9' 3"	16' 3"	18' 3"
20'	2-7 <sup>1</sup> / <sub>4</sub>	2-11 <sup>7</sup> / <sub>8</sub>	2-14	2-7 <sup>1</sup> / <sub>4</sub>	2-11 <sup>7</sup> / <sub>8</sub>	2-14	2-7 <sup>1</sup> / <sub>4</sub>	2-14	2-14	2-7 <sup>1</sup> / <sub>4</sub>	2-11 <sup>1</sup> / <sub>4</sub>	2-11 <sup>7</sup> / <sub>8</sub>	2-7 <sup>1</sup> / <sub>4</sub>	2-11 <sup>1</sup> / <sub>4</sub>	2-14	2-7 <sup>1</sup> / <sub>4</sub>	2-11 <sup>7</sup> / <sub>8</sub>	2-14
	-	3-11 <sup>1</sup> / <sub>4</sub>	3-11 <sup>1</sup> / <sub>4</sub>	-	3-11 <sup>1</sup> / <sub>4</sub>	3-11 <sup>7</sup> / <sub>8</sub>	-	3-11 <sup>1</sup> / <sub>4</sub>	-	3-5 <sup>1</sup> / <sub>2</sub>	3-9 <sup>1</sup> / <sub>4</sub>	3-11 <sup>1</sup> / <sub>4</sub>	3-5 <sup>1</sup> / <sub>2</sub>	3-9 <sup>1</sup> / <sub>2</sub>	3-11 <sup>1</sup> / <sub>4</sub>	-	3-11 <sup>1</sup> / <sub>4</sub>	3-11 <sup>1</sup> / <sub>4</sub>
24'	2-7 <sup>1</sup> / <sub>4</sub>	2-11 <sup>7</sup> / <sub>8</sub>	2-14	2-7 <sup>1</sup> / <sub>4</sub>	2-14	2-14	2-9 <sup>1</sup> / <sub>4</sub>	2-14	2-16*	2-7 <sup>1</sup> / <sub>4</sub>	2-11 <sup>1</sup> / <sub>4</sub>	2-14	2-7 <sup>1</sup> / <sub>4</sub>	2-11 <sup>7</sup> / <sub>8</sub>	2-14	2-7 <sup>1</sup> / <sub>4</sub>	2-11 <sup>7</sup> / <sub>8</sub>	2-14
	-	3-11 <sup>1</sup> / <sub>4</sub>	3-11 <sup>7</sup> / <sub>8</sub>	-	3-11 <sup>1</sup> / <sub>4</sub>	-	3-7 <sup>1</sup> / <sub>4</sub>	3-11 <sup>7</sup> / <sub>8</sub>	3-14	3-5 <sup>1</sup> / <sub>2</sub>	-	3-11 <sup>1</sup> / <sub>4</sub>	-	3-11 <sup>1</sup> / <sub>4</sub>	3-11 <sup>1</sup> / <sub>4</sub>	-	3-11 <sup>1</sup> / <sub>4</sub>	3-11 <sup>7</sup> / <sub>8</sub>
28'	2-7 <sup>1</sup> / <sub>4</sub>	2-14	2-14	2-9 <sup>1</sup> / <sub>4</sub>	2-14	2-16	2-9 <sup>1</sup> / <sub>4</sub>	2-16*	2-16*	2-7 <sup>1</sup> / <sub>4</sub>	2-11 <sup>7</sup> / <sub>8</sub>	2-14	2-7 <sup>1</sup> / <sub>4</sub>	2-14	2-14	2-7 <sup>1</sup> / <sub>4</sub>	2-14	2-14
	-	3-11 <sup>1</sup> / <sub>4</sub>	-	3-7 <sup>1</sup> / <sub>4</sub>	3-11 <sup>1</sup> / <sub>4</sub>	3-14	3-7 <sup>1</sup> / <sub>4</sub>	3-14	3-14	-	3-11 <sup>1</sup> / <sub>4</sub>	3-11 <sup>1</sup> / <sub>4</sub>	-	3-11 <sup>1</sup> / <sub>4</sub>	3-11 <sup>7</sup> / <sub>8</sub>	-	3-11 <sup>1</sup> / <sub>4</sub>	-
32'	2-9 <sup>1</sup> / <sub>4</sub>	2-14	2-16	2-9 <sup>1</sup> / <sub>4</sub>	2-14	2-16*	2-9 <sup>1</sup> / <sub>4</sub>	2-16*	2-18*	2-7 <sup>1</sup> / <sub>4</sub>	2-11 <sup>7</sup> / <sub>8</sub>	2-14	2-7 <sup>1</sup> / <sub>4</sub>	2-14	2-14	2-9 <sup>1</sup> / <sub>4</sub>	2-14	2-16
	3-7 <sup>1</sup> / <sub>4</sub>	3-11 <sup>7</sup> / <sub>8</sub>	3-14	3-7 <sup>1</sup> / <sub>4</sub>	3-11 <sup>7</sup> / <sub>8</sub>	3-14	3-7 <sup>1</sup> / <sub>4</sub>	3-14	3-14	-	3-11 <sup>1</sup> / <sub>4</sub>	3-11 <sup>7</sup> / <sub>8</sub>	-	3-11 <sup>1</sup> / <sub>4</sub>	-	3-7 <sup>1</sup> / <sub>4</sub>	3-11 <sup>7</sup> / <sub>8</sub>	3-14
36'	2-9 <sup>1</sup> / <sub>4</sub>	2-14	2-16*	2-9 <sup>1</sup> / <sub>4</sub>	2-16*	2-18*	2-9 <sup>1</sup> / <sub>4</sub>	2-16*	2-18*	2-7 <sup>1</sup> / <sub>4</sub>	2-14	2-14	2-9 <sup>1</sup> / <sub>4</sub>	2-14	2-16	2-9 <sup>1</sup> / <sub>4</sub>	2-14	2-16*
	3-7 <sup>1</sup> / <sub>4</sub>	3-11 <sup>7</sup> / <sub>8</sub>	3-14	3-7 <sup>1</sup> / <sub>4</sub>	3-14	3-14	-	3-14	3-16	-	3-11 <sup>1</sup> / <sub>4</sub>	-	3-7 <sup>1</sup> / <sub>4</sub>	3-11 <sup>1</sup> / <sub>4</sub>	3-14	3-7 <sup>1</sup> / <sub>4</sub>	3-11 <sup>7</sup> / <sub>8</sub>	3-14

**Notes:**

1. Table indicates the number of 1<sup>3</sup>/<sub>4</sub>" wide LVL plies to be used for the given application.
2. Assumes simple span measured from the inside face of bearing. Assumed bearing length is 3" each end (\* indicates 4<sup>1</sup>/<sub>2</sub>" end bearing).
3. Roof truss framing with 24" soffits.
4. Maximum beam deflection = L/240 LL, L/180 TL.
5. Table indicates LVL beams laterally braced at the top edge at maximum 24" o.c. by framing fastened directly to the LVL or to single or double top plate nailed to the LVL. Dropped headers (with cripple studs above) may have reduced capacity due to unbraced length and are beyond the scope of this table.

Accounting for a second-story floor and wall, these tables provide two selections for supporting roof loads over standard garage-door openings in various conditions.

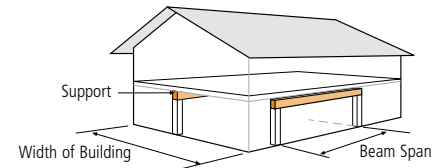

**2-Story Application Table - 2.0E, 2.1E, 2.2E Garage Door Headers - 1<sup>3</sup>/<sub>4</sub>" Width**

Width of Building	Snow 115%									Non-Snow 125%								
	25 psf LL + 20 psf DL			30 psf LL + 20 psf DL			40 psf LL + 20 psf DL			20 psf LL + 15 psf DL			20 psf LL + 20 psf DL			20 psf LL + 25 psf DL		
	9' 3"	16' 3"	18' 3"	9' 3"	16' 3"	18' 3"	9' 3"	16' 3"	18' 3"	9' 3"	16' 3"	18' 3"	9' 3"	16' 3"	18' 3"	9' 3"	16' 3"	18' 3"
20'	2-9 <sup>1</sup> / <sub>4</sub>	2-16	2-18*	2-9 <sup>1</sup> / <sub>4</sub>	2-16*	2-18*	2-9 <sup>1</sup> / <sub>4</sub>	2-16*	2-18*	2-9 <sup>1</sup> / <sub>4</sub>	2-14	2-16	2-9 <sup>1</sup> / <sub>4</sub>	2-16	2-16	2-9 <sup>1</sup> / <sub>4</sub>	2-16	2-18*
	-	3-14	3-16	-	3-14	3-16	3-9 <sup>1</sup> / <sub>4</sub>	3-14	3-16	3-7 <sup>1</sup> / <sub>4</sub>	-	3-14	3-7 <sup>1</sup> / <sub>4</sub>	3-14	3-14	-	3-14	3-16
24'	2-9 <sup>1</sup> / <sub>4</sub>	2-16*	2-18*	2-9 <sup>1</sup> / <sub>4</sub>	2-16*	2-18*	2-9 <sup>1</sup> / <sub>2</sub>	2-18*	3-16	2-9 <sup>1</sup> / <sub>4</sub>	2-16	2-18*	2-9 <sup>1</sup> / <sub>4</sub>	2-16*	2-18*	2-9 <sup>1</sup> / <sub>4</sub>	2-16*	2-18*
	-	3-14	3-16	-	3-14	3-16	3-9 <sup>1</sup> / <sub>4</sub>	3-16	-	-	3-14	3-16	-	3-14	3-16	-	3-14	3-16
28'	2-9 <sup>1</sup> / <sub>4</sub>	2-16*	2-18*	2-9 <sup>1</sup> / <sub>2</sub>	2-18*	3-18	2-11 <sup>1</sup> / <sub>4</sub>	2-18*	3-18*	2-9 <sup>1</sup> / <sub>4</sub>	2-16*	2-18*	2-9 <sup>1</sup> / <sub>4</sub>	2-16*	2-18*	2-9 <sup>1</sup> / <sub>4</sub>	2-16*	2-18*
	-	3-14	3-16	3-9 <sup>1</sup> / <sub>4</sub>	3-16	-	3-9 <sup>1</sup> / <sub>4</sub>	3-16	-	-	3-14	3-16	-	3-14	3-16	-	3-14	3-16
32'	2-11 <sup>1</sup> / <sub>4</sub>	2-18*	3-18*	2-11 <sup>1</sup> / <sub>4</sub>	2-18*	3-18*	2-11 <sup>1</sup> / <sub>4</sub>	3-16*	3-18*	2-9 <sup>1</sup> / <sub>4</sub>	2-16*	2-18*	2-9 <sup>1</sup> / <sub>2</sub>	2-18*	3-16	2-11 <sup>1</sup> / <sub>4</sub>	2-18*	3-18*
	3-9 <sup>1</sup> / <sub>4</sub>	3-16	-	3-9 <sup>1</sup> / <sub>4</sub>	3-16	-	3-9 <sup>1</sup> / <sub>4</sub>	-	-	-	3-14	3-16	3-9 <sup>1</sup> / <sub>4</sub>	3-16	-	3-9 <sup>1</sup> / <sub>4</sub>	3-16	-
36'	2-11 <sup>1</sup> / <sub>4</sub>	2-18*	3-18*	2-11 <sup>1</sup> / <sub>4</sub>	3-16*	3-18*	2-11 <sup>1</sup> / <sub>4</sub>	3-16*	3-18*	2-9 <sup>1</sup> / <sub>2</sub>	2-18*	3-18	2-11 <sup>1</sup> / <sub>4</sub>	2-18*	3-18*	2-11 <sup>1</sup> / <sub>4</sub>	2-18*	3-18*
	3-9 <sup>1</sup> / <sub>4</sub>	3-16*	-	3-9 <sup>1</sup> / <sub>4</sub>	-	-	3-9 <sup>1</sup> / <sub>4</sub>	-	-	-	3-16	-	3-9 <sup>1</sup> / <sub>4</sub>	3-16	-	3-9 <sup>1</sup> / <sub>4</sub>	3-16*	-

**Notes:**

1. Table indicates the number of 1<sup>3</sup>/<sub>4</sub>" wide LVL plies to be used for the given application.
2. Assumes simple span measured from the inside face of bearing. Assumed bearing length is 3" each end (\* indicates 4<sup>1</sup>/<sub>2</sub>" end bearing).
3. Roof truss framing with 24" soffits.
4. Floor beam is located at the centerline of the building; 40 psf floor LL, 12 psf floor DL.
5. Exterior wall weight of 80 plf.
6. Max beam defl = L/360 LL, L/240 TL.
7. Table indicates LVL beams laterally braced at the top edge at maximum 24" o.c. by framing fastened directly to the LVL or to single or double top plate nailed to the LVL. Dropped headers (with cripple studs above) may have reduced capacity due to unbraced length and are beyond the scope of this table.

# Window/Door Headers

These tables provide two selections for supporting roof loads over rough openings in various conditions.

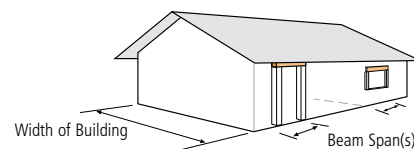

## 1-Story Application Table - 2.0E, 2.1E, 2.2E Window & Door Headers - 1 3/4" Width

Width of Building	Snow 115%										Non-Snow 125%									
	25 psf LL + 20 psf DL					40 psf LL + 20 psf DL					20 psf LL + 15 psf DL					20 psf LL + 25 psf DL				
	6'	8'	9'	10'	12'	6'	8'	9'	10'	12'	6'	8'	9'	10'	12'	6'	8'	9'	10'	12'
20'	2-5 1/2	2-7 1/4	2-7 1/4	2-7 1/4	2-9 1/4	2-5 1/2	2-7 1/4	2-7 1/4	2-9 1/4	2-9 1/4	2-5 1/2	2-5 1/2	2-7 1/4	2-7 1/4	2-9 1/4	2-5 1/2	2-7 1/4	2-7 1/4	2-7 1/4	2-9 1/4
	-	3-5 1/2	-	-	-	-	3-5 1/2	-	3-7 1/4	-	-	-	3-5 1/2	-	3-7 1/4	-	3-5 1/2	-	-	-
24'	2-5 1/2	2-7 1/4	2-7 1/4	2-9 1/4	2-9 1/4	2-5 1/2	2-7 1/4	2-9 1/4	2-9 1/4	2-11 1/4	2-5 1/2	2-5 1/2	2-7 1/4	2-7 1/4	2-9 1/4	2-5 1/2	2-7 1/4	2-7 1/4	2-9 1/4	2-9 1/4
	-	3-5 1/2	-	3-7 1/4	-	-	-	-	3-7 1/4	3-7 1/4	3-9 1/4	-	-	3-5 1/2	-	3-7 1/4	-	3-5 1/2	-	3-7 1/4
28'	2-5 1/2	2-7 1/4	2-7 1/4	2-9 1/4	2-9 1/4	2-5 1/2	2-7 1/4	2-9 1/4	2-9 1/4	2-11 1/4	2-5 1/2	2-7 1/4	2-7 1/4	2-7 1/4	2-9 1/4	2-5 1/2	2-7 1/4	2-7 1/4	2-9 1/4	2-9 1/4
	-	3-5 1/2	-	3-7 1/4	-	-	-	-	3-7 1/4	-	3-9 1/4	-	3-5 1/2	-	-	-	3-5 1/2	-	3-7 1/4	-
32'	2-5 1/2	2-7 1/4	2-7 1/4	2-9 1/4	2-11 1/4	2-5 1/2	2-7 1/4	2-9 1/4	2-9 1/4	2-11 1/4	2-5 1/2	2-7 1/4	2-7 1/4	2-9 1/4	2-9 1/4	2-5 1/2	2-7 1/4	2-7 1/4	2-9 1/4	2-11 1/4
	-	-	-	3-7 1/4	3-9 1/4	-	-	-	3-7 1/4	-	3-9 1/4	-	3-5 1/2	-	3-7 1/4	-	-	-	-	3-7 1/4
36'	2-5 1/2	2-7 1/4	2-9 1/4	2-9 1/4	2-11 1/4	2-7 1/4	2-9 1/4	2-9 1/4	2-9 1/2	2-11 7/8	2-5 1/2	2-7 1/4	2-7 1/4	2-9 1/4	2-9 1/4	2-5 1/2	2-7 1/4	2-9 1/4	2-9 1/4	2-11 1/4
	-	-	3-7 1/4	3-7 1/4	3-9 1/4	3-5 1/2	3-7 1/4	3-7 1/4	3-9 1/4	-	-	3-5 1/2	-	3-7 1/4	-	-	-	-	3-7 1/4	3-9 1/4

### Notes:

1. Table indicates the number of 1 3/4" wide LVL plies to be used for the given application.
2. Assumes simple span measured from the inside face of bearing. Assumed bearing length is 3" each end (\* indicates 4 1/2" end bearing).
3. Roof truss framing with 24" soffits.
4. Maximum beam deflection = L/240 LL, L/180 TL.
5. Table indicates LVL beams laterally braced at the top edge at maximum 24" o.c. by framing fastened directly to the LVL or to single or double top plate nailed to the LVL. Dropped headers (with cripple studs above) may have reduced capacity due to unbraced length and are beyond the scope of this table.

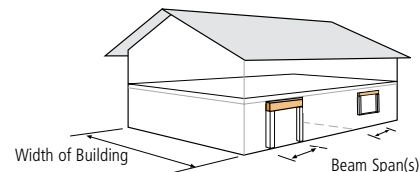

Accounting for a second-story floor and wall, these tables provide two selections for supporting roof loads over rough openings in various conditions.

## 2-Story Application Table - 2.0E, 2.1E, 2.2E LVL Window & Door Headers - 1 3/4" Width

Width of Building	Snow 115%										Non-Snow 125%									
	25 psf LL + 20 psf DL					40 psf LL + 20 psf DL					20 psf LL + 15 psf DL					20 psf LL + 25 psf DL				
	6'	8'	9'	10'	12'	6'	8'	9'	10'	12'	6'	8'	9'	10'	12'	6'	8'	9'	10'	12'
20'	2-7 1/4	2-9 1/4	2-9 1/4	2-9 1/4	2-11 1/4	2-7 1/4	2-9 1/4	2-9 1/4	2-11 1/4	2-11 7/8	2-5 1/2	2-7 1/4	2-9 1/4	3-5 1/2	2-11 1/4	2-7 1/4	2-9 1/4	2-9 1/4	2-9 1/4	2-11 1/4
	3-5 1/2	3-7 1/4	3-7 1/4	-	3-9 1/2	3-5 1/2	3-7 1/4	-	3-9 1/4	3-11 1/4	-	-	3-7 1/4	3-9 1/4	3-9 1/4	3-5 1/2	3-7 1/4	3-7 1/4	-	3-9 1/2
24'	2-7 1/4	2-9 1/4	2-9 1/4	2-9 1/2	2-11 7/8	2-7 1/4	2-9 1/4	2-9 1/4	2-11 1/4	2-14	2-7 1/4	2-9 1/4	2-9 1/4	2-9 1/4	2-11 1/4	2-7 1/4	2-9 1/4	2-9 1/4	2-9 1/2	2-11 7/8
	3-5 1/2	3-7 1/4	-	3-9 1/4	3-11 1/4	3-5 1/2	3-7 1/4	-	3-9 1/4	3-11 1/4	3-5 1/2	3-7 1/4	3-7 1/4	-	3-9 1/2	3-5 1/2	3-7 1/4	-	3-9 1/4	3-11 1/4
28'	2-7 1/4	2-9 1/4	2-9 1/4	2-11 1/4	2-11 7/8	2-7 1/4	2-9 1/4	2-11 1/4	2-11 1/4	2-14*	2-7 1/4	2-9 1/4	2-9 1/4	2-9 1/2	2-11 7/8	2-7 1/4	2-9 1/4	2-9 1/4	2-11 1/4	2-11 7/8
	3-5 1/2	3-7 1/4	-	3-9 1/4	3-11 1/4	-	-	3-9 1/4	3-9 1/4	3-11 1/4	3-5 1/2	3-7 1/4	-	3-9 1/4	3-11 1/4	3-5 1/2	3-7 1/4	-	3-9 1/4	3-11 1/4
32'	2-7 1/4	2-9 1/4	2-9 1/2	2-11 1/4	2-14*	2-7 1/4	2-9 1/4	2-11 1/4	2-11 1/4*	2-14*	2-7 1/4	2-9 1/4	2-9 1/4	2-11 1/4	2-11 7/8	2-7 1/4	2-9 1/4	2-9 1/2	2-11 1/4	2-14*
	3-5 1/2	3-7 1/4	3-9 1/4	3-9 1/4	3-11 1/4	-	-	3-9 1/4	3-11 1/4	3-11 7/8	3-5 1/2	3-7 1/4	-	3-9 1/4	3-11 1/4	3-5 1/2	3-7 1/4	3-9 1/4	3-9 1/4	3-11 1/4
36'	2-7 1/4	2-9 1/4	2-11 1/4	2-11 1/4	2-14*	2-7 1/4	2-9 1/4	2-11 1/4*	2-11 7/8*	2-16*	2-7 1/4	2-9 1/4	2-9 1/4	2-11 1/4	2-14	2-7 1/4	2-9 1/4	2-11 1/4	2-11 1/4	2-14*
	-	-	3-9 1/4	3-9 1/2	3-11 1/4	-	-	3-9 1/4	3-11 1/4	3-11 7/8	3-5 1/2	3-7 1/4	-	3-9 1/4	3-11 1/4	-	-	3-9 1/4	3-9 1/2	3-11 1/4

### Notes:

1. Table indicates the number of 1 3/4" wide LVL plies to be used for the given application.
2. Assumes simple span measured from the inside face of bearing. Assumed bearing length is 3" each end (\* indicates 4 1/2" end bearing).
3. Roof truss framing with 24" soffits.
4. Floor beam is located at the centerline of the building; 40 psf floor LL, 12 psf floor DL.
5. Exterior wall weight of 80 plf.
6. Max beam defl = L/360 LL, L/240 TL.
7. Table indicates LVL beams laterally braced at the top edge at maximum 24" o.c. by framing fastened directly to the LVL or to single or double top plate nailed to the LVL. Dropped headers (with cripple studs above) may have reduced capacity due to unbraced length and are beyond the scope of this table.



# Allowable Floor Loads

## Allowable Uniform Loads (plf) - 2.0E, 2.1E, 2.2E - Floor 100% - 1<sup>3</sup>/<sub>4</sub>" Width

Span (ft)	7 <sup>1</sup> / <sub>4</sub> "			9 <sup>1</sup> / <sub>4</sub> "			9 <sup>1</sup> / <sub>2</sub> "			11 <sup>1</sup> / <sub>4</sub> "		
	Live Load		Total Load L/240	Live Load		Total Load L/240	Live Load		Total Load L/240	Live Load		Total Load L/240
	L/480	L/360		L/480	L/360		L/480	L/360		L/480	L/360	
6'	568	759	776	1046	1046	1046	1082	1082	1082	1348	1348	1348
8'	238	318	479	496	663	735	538	719	759	895	931	931
9'	166	222	335	347	464	640	376	503	660	627	806	806
10'	120	161	243	252	337	508	273	366	551	456	609	711
11'	89	120	182	188	252	381	204	273	413	341	456	632
12'	68	92	139	144	193	292	156	210	317	261	350	528
13'	53	71	109	112	151	229	122	164	248	204	274	414
14'	-	56	86	89	120	182	96	130	198	162	218	331
15'	-	45	69	71	97	147	77	105	160	131	177	268
16'	-	-	-	58	79	121	63	86	131	107	144	220
18'	-	-	-	39	54	83	43	59	90	73	100	152
20'	-	-	-	-	38	59	-	41	65	52	71	110
22'	-	-	-	-	-	-	-	-	-	38	52	81
24'	-	-	-	-	-	-	-	-	-	-	39	61
26'	-	-	-	-	-	-	-	-	-	-	-	-

Span (ft)	11 <sup>7</sup> / <sub>8</sub> "			14"			16"			18"		
	Live Load		Total Load L/240	Live Load		Total Load L/240	Live Load		Total Load L/240	Live Load		Total Load L/240
	L/480	L/360		L/480	L/360		L/480	L/360		L/480	L/360	
6'	1449	1449	1449	1826	1826	1826	2232	2232	2232	2697	2697	2697
8'	996	996	996	1229	1229	1229	1468	1468	1468	1731	1731	1731
9'	738	861	861	1055	1055	1055	1253	1253	1253	1467	1467	1467
10'	537	718	758	882	925	925	1093	1093	1093	1273	1273	1273
11'	402	538	677	661	823	823	969	969	969	1124	1124	1124
12'	308	413	585	507	679	741	760	870	870	1006	1006	1006
13'	241	323	488	398	533	673	596	789	789	851	910	910
14'	192	258	389	317	425	579	476	637	722	680	831	831
15'	155	208	316	256	344	504	385	516	643	551	737	764
16'	126	171	259	210	282	427	316	424	564	452	606	700
18'	87	118	180	145	196	298	219	295	444	315	423	551
20'	62	84	130	104	141	215	158	213	324	227	306	445
22'	45	62	96	76	104	160	116	158	241	168	227	346
24'	-	46	72	57	79	122	88	120	184	128	173	264
26'	-	-	-	43	60	94	67	93	143	98	134	206
28'	-	-	-	-	47	74	52	72	113	77	106	163
30'	-	-	-	-	37	59	41	57	90	61	84	131
32'	-	-	-	-	-	-	-	46	73	48	68	106
34'	-	-	-	-	-	-	-	-	-	39	55	87

- Notes:**
1. Single 1<sup>3</sup>/<sub>4</sub>" members are limited to 14" in depth. For multiple member applications, multiply the allowable uniform load by the corresponding number of plies in the built-up beam.
  2. Table displays the maximum uniform load which may be applied to the member in addition to its own weight.
  3. Total load deflection is limited to L/240.
  4. Assumes the more restrictive of simple or continuous (2 span) condition.
  5. Spans are measured from the center to center of bearing.
  6. Depths of 16" and greater should be used with a minimum of two plies unless designed specifically as a single ply of 1<sup>3</sup>/<sub>4</sub>" with proper lateral bracing spaced at 24" along the length of the beam. (Example: the marriage beam for each half of a manufactured home before units are joined.)
  7. Table indicates LVL beams continuously laterally braced at the top edge by subfloor (for joist application) or at maximum 24" o.c. by framing fastened directly to the LVL or to single or double top plate nailed to the LVL.
  8. Table is based on 1<sup>3</sup>/<sub>4</sub>" width. Values may be multiplied by 2 for 3<sup>1</sup>/<sub>2</sub>" width, 3 for 5<sup>1</sup>/<sub>4</sub>", and 4 for 7".

## Allowable Uniform Loads (plf) - 2.0E, 2.1E, 2.2E - Floor 100% - 1<sup>3</sup>/<sub>4</sub>" Width

Span (ft)	20"			22"			24"		
	Live Load		Total Load L/240	Live Load		Total Load L/240	Live Load		Total Load L/240
	L/480	L/360		L/480	L/360		L/480	L/360	
6'	3238	3238	3238	3872	3872	3872	4628	4628	4628
8'	2020	2020	2020	2339	2339	2339	2694	2694	2694
9'	1699	1699	1699	1952	1952	1952	2228	2228	2228
10'	1466	1466	1466	1674	1674	1674	1898	1898	1898
11'	1289	1289	1289	1465	1465	1465	1653	1653	1653
12'	1150	1150	1150	1302	1302	1302	1464	1464	1464
13'	1038	1038	1038	1172	1172	1172	1313	1313	1313
14'	945	945	945	1065	1065	1065	1191	1191	1191
15'	768	868	868	976	976	976	1089	1089	1089
16'	633	802	802	842	900	900	1003	1003	1003
18'	445	593	669	592	779	779	768	866	866
20'	324	432	540	431	575	643	560	747	754
22'	243	325	444	324	432	529	421	561	621
24'	188	250	365	250	333	443	324	432	520
26'	148	197	285	196	262	376	255	340	441
28'	118	157	226	157	210	303	204	272	379
30'	96	128	182	128	170	244	166	221	320
32'	79	105	148	105	140	199	137	182	261
34'	66	88	122	88	117	164	114	152	216

### Notes:

1. Single 1<sup>3</sup>/<sub>4</sub>" members are limited to 14" in depth. For multiple member applications, multiply the allowable uniform load by the corresponding number of plies in the built-up beam.
2. Table displays the maximum uniform load which may be applied to the member in addition to it's own weight.
3. Total load deflection is limited to L/240.
4. Assumes the more restrictive of simple or continuous (2 span) condition.
5. Spans are measured from the center to center of bearing.
6. Depths of 16" and greater should be used with a minimum of two plies unless designed specifically as a single ply of 1<sup>3</sup>/<sub>4</sub>" with proper lateral bracing spaced at 24" along the length of the beam. (Example: the marriage beam for each half of a manufactured home before units are joined.)
7. Table indicates LVL beams continuously laterally braced at the top edge by subfloor (for joist application) or at maximum 24" o.c. by framing fastened directly to the LVL or to single or double top plate nailed to the LVL.
8. Table is based on 1<sup>3</sup>/<sub>4</sub>" width. Values may be multiplied by 2 for 3<sup>1</sup>/<sub>2</sub>" width, 3 for 5<sup>1</sup>/<sub>4</sub>", and 4 for 7".



# Allowable Roof Loads

## Allowable Uniform Loads (plf) - 2.0E, 2.1E, 2.2E - Roof - 1 3/4" Width

Span (ft)	7 1/4"				9 1/4"				9 1/2"				11 1/4"			
	Snow 115%		Non-Snow 125%		Snow 115%		Non-Snow 125%		Snow 115%		Non-Snow 125%		Snow 115%		Non-Snow 125%	
	Live	Total	Live	Total	Live	Total	Live	Total	Live	Total	Live	Total	Live	Total	Live	Total
	L/240	L/180	L/240	L/180	L/240	L/180	L/240	L/180	L/240	L/180	L/240	L/180	L/240	L/180	L/240	L/180
6'	893	893	971	971	1203	1203	1308	1308	1245	1245	1353	1353	1551	1551	1686	1686
8'	479	620	479	640	846	846	920	920	873	873	950	950	1072	1072	1165	1165
9'	335	448	335	448	699	737	699	801	757	760	757	826	928	928	1009	1009
10'	243	326	243	326	508	617	508	671	551	648	551	704	818	818	890	890
11'	182	244	182	244	381	509	381	509	413	534	413	552	688	728	688	792
12'	139	187	139	187	292	391	292	391	317	424	317	424	528	611	528	664
13'	109	146	109	146	229	307	229	307	248	332	248	332	414	519	414	554
14'	86	116	86	116	182	245	182	245	198	265	198	265	331	443	331	443
15'	69	94	69	94	147	198	147	198	160	215	160	215	268	359	268	359
16'	57	77	57	77	121	162	121	162	131	176	131	176	220	295	220	295
18'	-	-	-	-	83	113	83	113	90	122	90	122	152	205	152	205
20'	-	-	-	-	59	81	59	81	65	88	65	88	110	148	110	148
22'	-	-	-	-	-	-	-	-	47	65	47	65	81	110	81	110
24'	-	-	-	-	-	-	-	-	-	-	-	-	61	83	61	83
26'	-	-	-	-	-	-	-	-	-	-	-	-	47	64	47	64
28'	-	-	-	-	-	-	-	-	-	-	-	-	-	-	-	-

Span (ft)	11 7/8"				14"				16"				18"			
	Snow 115%		Non-Snow 125%		Snow 115%		Non-Snow 125%		Snow 115%		Non-Snow 125%		Snow 115%		Non-Snow 125%	
	Live	Total	Live	Total	Live	Total	Live	Total	Live	Total	Live	Total	Live	Total	Live	Total
	L/240	L/180	L/240	L/180	L/240	L/180	L/240	L/180	L/240	L/180	L/240	L/180	L/240	L/180	L/240	L/180
6'	1668	1668	1813	1813	2101	2101	2285	2285	2568	2568	2792	2792	3103	3103	3374	3374
8'	1146	1146	1246	1246	1414	1414	1537	1537	1690	1690	1837	1837	1992	1992	2166	2166
9'	991	991	1077	1077	1215	1215	1321	1321	1442	1442	1569	1569	1689	1689	1836	1836
10'	872	872	949	949	1064	1064	1158	1158	1258	1258	1368	1368	1465	1465	1593	1593
11'	779	779	809	847	947	947	1030	1030	1115	1115	1213	1213	1294	1294	1407	1407
12'	622	674	622	733	853	853	928	928	1001	1001	1089	1089	1158	1158	1260	1260
13'	488	573	488	624	775	775	802	843	908	908	988	988	1048	1048	1140	1140
14'	389	494	389	521	641	667	641	726	831	831	904	904	957	957	1041	1041
15'	316	423	316	423	520	580	520	631	741	741	778	806	880	880	957	957
16'	259	347	259	347	427	509	427	554	640	650	640	707	806	806	877	877
18'	180	242	180	242	298	399	298	399	447	512	447	557	635	635	639	691
20'	130	175	130	175	215	289	215	289	324	413	324	434	463	513	463	558
22'	96	130	96	130	160	216	160	216	241	324	241	324	346	422	346	460
24'	72	99	72	99	122	164	122	164	184	248	184	248	264	353	264	355
26'	56	76	56	76	94	128	94	128	143	193	143	193	206	278	206	278
28'	-	-	-	-	74	101	74	101	113	153	113	153	163	220	163	220
30'	-	-	-	-	59	81	59	81	90	123	90	123	131	177	131	177
32'	-	-	-	-	47	65	47	65	73	100	73	100	106	145	106	145
34'	-	-	-	-	-	-	-	-	59	82	59	82	87	119	87	119

**Notes:**

1. Single 1 3/4" members are limited to 14" in depth. For multiple member applications, multiply the allowable uniform load by the corresponding number of plies in the built-up beam.
2. Table displays the maximum uniform load which may be applied to the member in addition to it's own weight.
3. Assumes the more restrictive of simple or continuous (2 span) condition.
4. Spans are measured from the center to center of bearing.
5. Depths of 16" and greater should be used with a minimum of two plies unless designed specifically as a single ply of 1 3/4" with proper lateral bracing spaced at 24" along the length of the beam. (Example: the marriage beam for each half of a manufactured home before units are joined.)
6. Table indicates LVL beams continuously laterally braced at the top edge by subfloor (for joist application) or at maximum 24" o.c. by framing fastened directly to the LVL or to single or double top plate nailed to the LVL.
7. Table is based on 1 3/4" width. Values may be multiplied by 2 for 3 1/2" width, 3 for 5 1/4", and 4 for 7".



## Allowable Uniform Loads (plf) - 2.0E, 2.1E, 2.2E - Roof - 1<sup>3</sup>/<sub>4</sub>" Width

Span (ft)	20"				22"				24"			
	Snow 115%		Non-Snow 125%		Snow 115%		Non-Snow 125%		Snow 115%		Non-Snow 125%	
	Live	Total	Live	Total	Live	Total	Live	Total	Live	Total	Live	Total
	L/240	L/180	L/240	L/180	L/240	L/180	L/240	L/180	L/240	L/180	L/240	L/180
6'	3725	3725	4050	4050	4455	4455	4843	4843	5324	5324	5788	5788
8'	2324	2324	2527	2527	2692	2692	2927	2927	3100	3100	3371	3371
9'	1956	1956	2127	2127	2246	2246	2443	2443	2564	2564	2788	2788
10'	1688	1688	1835	1835	1927	1927	2095	2095	2185	2185	2376	2376
11'	1484	1484	1614	1614	1687	1687	1834	1834	1903	1903	2070	2070
12'	1324	1324	1440	1440	1499	1499	1631	1631	1686	1686	1833	1833
13'	1195	1195	1299	1299	1349	1349	1468	1468	1512	1512	1645	1645
14'	1088	1088	1184	1184	1226	1226	1334	1334	1371	1371	1491	1491
15'	999	999	1087	1087	1124	1124	1222	1222	1254	1254	1364	1364
16'	924	924	1005	1005	1037	1037	1128	1128	1155	1155	1257	1257
18'	770	770	838	838	898	898	977	977	997	997	1085	1085
20'	622	622	648	677	741	741	806	806	869	869	945	945
22'	487	512	487	558	610	610	648	664	716	716	779	779
24'	375	429	375	467	499	511	499	556	600	600	648	653
26'	295	364	295	383	393	434	393	472	498	509	510	554
28'	236	305	236	305	314	372	314	406	408	437	408	476
30'	192	246	192	246	256	323	256	330	332	379	332	413
32'	158	201	158	201	211	270	211	270	273	332	273	352
34'	132	166	132	166	176	223	176	223	228	292	228	292

### Notes:

1. Single 1<sup>3</sup>/<sub>4</sub>" members are limited to 14" in depth. For multiple member applications, multiply the allowable uniform load by the corresponding number of plies in the built-up beam.
2. Table displays the maximum uniform load which may be applied to the member in addition to it's own weight.
3. Assumes the more restrictive of simple or continuous (2 span) condition.
4. Spans are measured from the center to center of bearing.
5. Depths of 16" and greater should be used with a minimum of two plies unless designed specifically as a single ply of 1<sup>3</sup>/<sub>4</sub>" with proper lateral bracing spaced at 24" along the length of the beam. (Example: the marriage beam for each half of a manufactured home before units are joined.)
6. Table indicates LVL beams continuously laterally braced at the top edge by subfloor (for joist application) or at maximum 24" o.c. by framing fastened directly to the LVL or to single or double top plate nailed to the LVL.
7. Table is based on 1<sup>3</sup>/<sub>4</sub>" width. Values may be multiplied by 2 for 3<sup>1</sup>/<sub>2</sub>" width, 3 for 5<sup>1</sup>/<sub>4</sub>", and 4 for 7".



# Allowable Column Loads

## Steel or Column Bearing

Column Length	3 1/2" x 3 1/2"			3 1/2" x 5 1/2"			3 1/2" x 7"		
	100%	115%	125%	100%	115%	125%	100%	115%	125%
6	12962	13613	13987	20358	21381	21967	25900	27200	27945
7	10550	10981	11228	16570	17245	17633	21081	21939	22431
8	8695	8995	9167	13656	14127	14397	17373	17971	18314
9	7264	7482	7607	11409	11751	11947	14514	14948	15197
10	6148	6311	6404	9655	9911	10058	12283	12608	12793
11	5264	5389	5461	8267	8463	8575	10516	10766	10908
12	4554	4652	4708	7152	7306	7394	9098	9293	9405
13	3976	4055	4100	6245	6368	6438	7944	8100	8188
14	3500	3564	3600	5497	5597	5654	6993	7119	7191
> 14	Not Permitted			Not Permitted			Not Permitted		

**Note:**  
1. Eccentricity of 1/6 the column width/thickness.

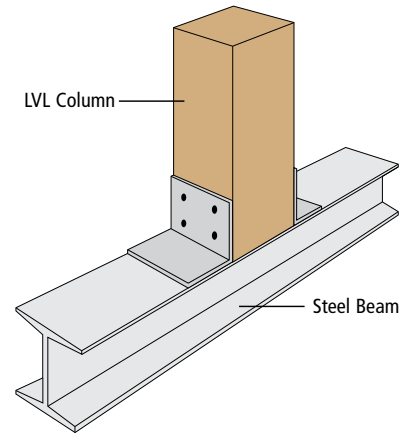

Column to beam connection by design professional

## Plate Bearing

Column Length	3 1/2" x 3 1/2"			3 1/2" x 5 1/2"			3 1/2" x 7"		
	100%	115%	125%	100%	115%	125%	100%	115%	125%
6	5206	5206	5206	8181	8181	8181	10412	10412	10412
7	5206	5206	5206	8181	8181	8181	10412	10412	10412
8	5206	5206	5206	8181	8181	8181	10412	10412	10412
9	5206	5206	5206	8181	8181	8181	10412	10412	10412
10	5206	5206	5206	8181	8181	8181	10412	10412	10412
11	5206	5206	5206	8181	8181	8181	10412	10412	10412
12	4554	4652	4708	7152	7306	7394	9098	9293	9405
13	3976	4055	4100	6245	6368	6438	7944	8100	8188
14	3500	3564	3600	5497	5597	5654	6993	7119	7191
> 14	Not Permitted			Not Permitted			Not Permitted		

Table displays the maximum column load as controlled by the column or the dimensional lumber plate below with  $F_{c\perp}$  = psi as a typical for #2 and Better Spruce, Pine, or Fir.

**Notes:**  
1. Assumes NDS 2005.  
2. Solid, one piece member.  
3. Effective column length equals the actual column length; ends are braced about both axis.

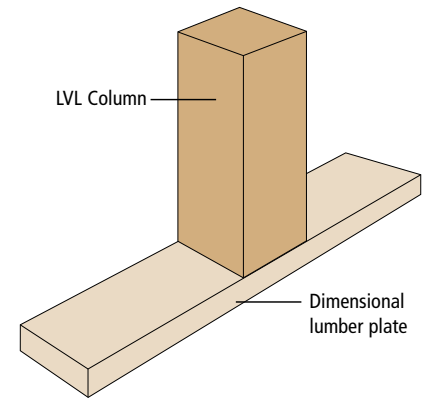

Column base not shown; verify capacity with manufacturer

## Bearing Length and Maximum Reaction (lbs)

Width (in) <sup>1</sup>	Bearing Length																					
	1 1/2"	2"	2 1/2"	3"	3 1/2"	4"	4 1/2"	5"	5 1/2"	6"	6 1/2"	7"	7 1/2"	8"	8 1/2"	9"	9 1/2"	10"	10 1/2"	11"	11 1/2"	12"
1 3/4"	1969	2625	3281	3938	4594	5250	5906	6563	7219	7875	8531	9188	9844	10500	11156	11813	12469	13125	13781	14438	15094	15750
3 1/2"	3938	5250	6563	7875	9188	10500	11813	13125	14438	15750	17063	18375	19688	21000	22313	23625	24938	26250	27563	28875	30188	31500
5 1/4"	5906	7875	9844	11813	13781	15750	17719	19688	21656	23625	25594	27563	29531	31500	33469	35438	37406	39375	41344	43313	45281	47250
7"	7875	10500	13125	15750	18375	21000	23625	26250	28875	31500	34125	36750	39375	42000	44625	47250	49875	52500	55125	57750	60375	63000

**Notes:**  
1. Use any combination of 1 3/4" and 3 1/2" members using proper nailing or bolting guidelines.  
2. Minimum bearing length is 1 1/2". Bearing across the full width of the beam is required.  
3. Reported bearing length is based on 750 psi compression perpendicular to grain stress of the LVL member.  
Beams bearing on #2 and better, 2x plates must be increased by the following factor:  
Spruce-Pine-Fir 1.76  
Southern Yellow Pine 1.33  
Douglas Fir 1.20

## Sealer

All Murphy Company LVL is fully sealed with a factory applied industry-leading premium grade sealer. The sealer repels water absorption and improves durability during typical yard distribution and jobsite storage conditions.

## FSC® Certification

Murphy Company has achieved Forestry Stewardship Council™ Chain of Custody Certification. This ensures Murphy customers have a verifiable connection between their companies and certified manufacturers who adhere to the requirements of the FSC certification program. Murphy Company LVL products are available with this chain of custody. Builders who utilize products manufactured from forests certified by FSC, with an intact chain of custody, can qualify for points in the US Green Building Council's LEED system, a third-party certification program and benchmark for the design, construction, and operation of high-performance green buildings.

## Sizing Software

We have partnered with Calculated Structured Designs, an industry leader in software development, to better assist engineers, designers and specifiers. isDesign, our single member sizing program, recognizes all the United States building codes and offers printable design calculations and beam capabilities. The software user can specify simple span applications, point loads, cantilevers, and many more common applications. Please contact Murphy EWD to learn more about receiving a complimentary copy of isDesign software.

## Handling and Storage Guidelines

- LVL should be protected from the weather and stored lying flat.
- Product must not be stored in contact with the ground.
- Store LVL in wrapped bundles, provide air circulation and support bundles with 2x4 stickers.
- Protect from the weather on the job site both before and after installation. LVL is intended for use in covered, dry conditions only.
- Except as described in this product guide, LVL should not be cut, drilled or notched.
- Do not install wet or visually damaged product.
- Once a factory sealed LVL product is cut, a coat of water repellent sealer should be applied to the freshly cut end to prevent moisture from entering the cut end.

## Installation Instructions

Murphy Company has full installation instructions for LVL including connections, notching and hole locations. Please see the technical documentation at [www.murphyplywood.com](http://www.murphyplywood.com) or contact your Murphy LVL salesperson for additional information.



The mark of  
responsible forestry



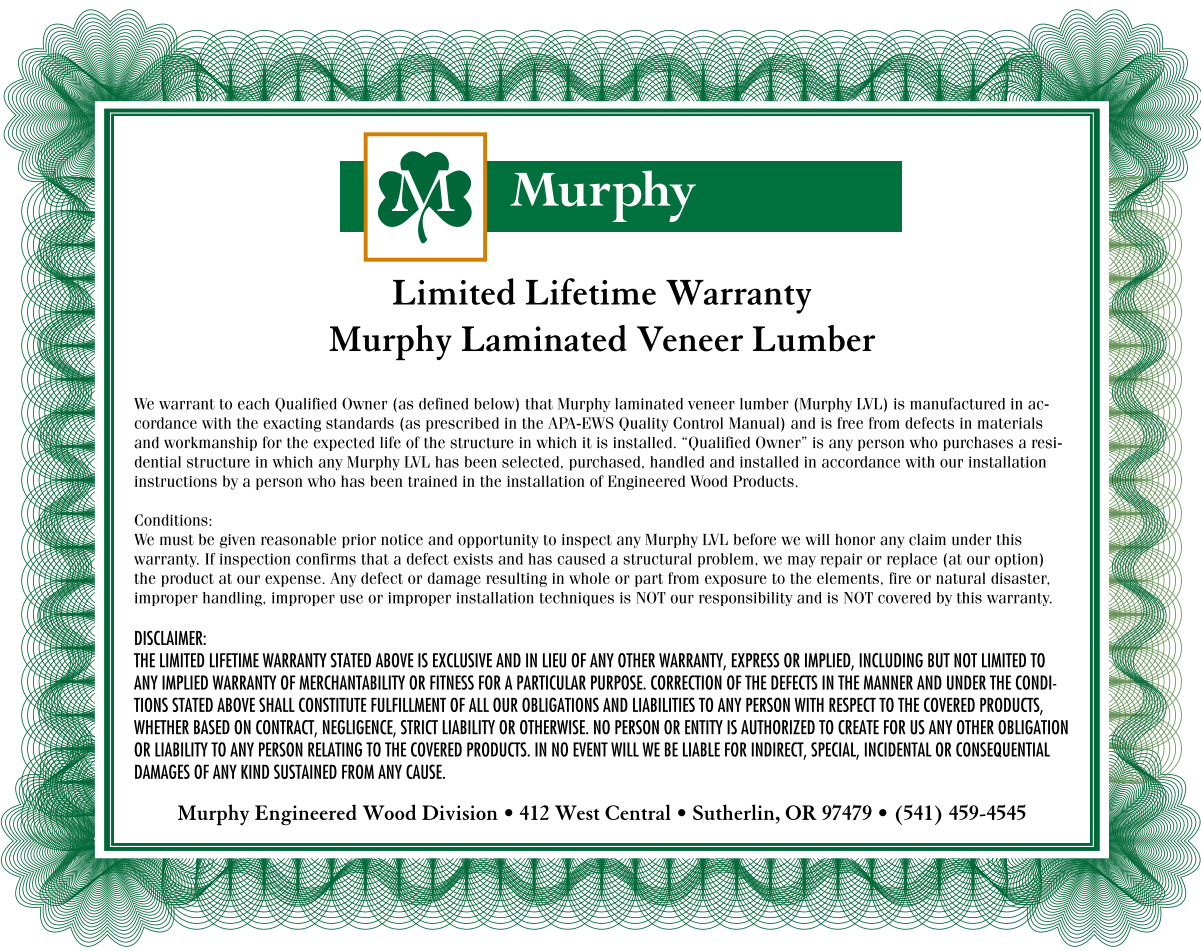



**Limited Lifetime Warranty**  
**Murphy Laminated Veneer Lumber**

We warrant to each Qualified Owner (as defined below) that Murphy laminated veneer lumber (Murphy LVL) is manufactured in accordance with the exacting standards (as prescribed in the APA-EWS Quality Control Manual) and is free from defects in materials and workmanship for the expected life of the structure in which it is installed. "Qualified Owner" is any person who purchases a residential structure in which any Murphy LVL has been selected, purchased, handled and installed in accordance with our installation instructions by a person who has been trained in the installation of Engineered Wood Products.

**Conditions:**  
 We must be given reasonable prior notice and opportunity to inspect any Murphy LVL before we will honor any claim under this warranty. If inspection confirms that a defect exists and has caused a structural problem, we may repair or replace (at our option) the product at our expense. Any defect or damage resulting in whole or part from exposure to the elements, fire or natural disaster, improper handling, improper use or improper installation techniques is NOT our responsibility and is NOT covered by this warranty.

**DISCLAIMER:**  
 THE LIMITED LIFETIME WARRANTY STATED ABOVE IS EXCLUSIVE AND IN LIEU OF ANY OTHER WARRANTY, EXPRESS OR IMPLIED, INCLUDING BUT NOT LIMITED TO ANY IMPLIED WARRANTY OF MERCHANTABILITY OR FITNESS FOR A PARTICULAR PURPOSE. CORRECTION OF THE DEFECTS IN THE MANNER AND UNDER THE CONDITIONS STATED ABOVE SHALL CONSTITUTE FULFILLMENT OF ALL OUR OBLIGATIONS AND LIABILITIES TO ANY PERSON WITH RESPECT TO THE COVERED PRODUCTS, WHETHER BASED ON CONTRACT, NEGLIGENCE, STRICT LIABILITY OR OTHERWISE. NO PERSON OR ENTITY IS AUTHORIZED TO CREATE FOR US ANY OTHER OBLIGATION OR LIABILITY TO ANY PERSON RELATING TO THE COVERED PRODUCTS. IN NO EVENT WILL WE BE LIABLE FOR INDIRECT, SPECIAL, INCIDENTAL OR CONSEQUENTIAL DAMAGES OF ANY KIND SUSTAINED FROM ANY CAUSE.

Murphy Engineered Wood Division • 412 West Central • Sutherlin, OR 97479 • (541) 459-4545

## Technical Support

While supplying a superior product, Murphy Company is dedicated to providing an unprecedented level of support for our customers. Phone support, bulletins, a broad library of technical materials, and other relevant information are available.

Our highly trained technical services staff, led by industry veterans, combined with extensive knowledge and state-of-the-art tools, assist with design or construction questions and provide full support for our design software.



**MURPHY**  
 Engineered Wood

412 West Central Ave.  
 Sutherlin, OR  
 97479

OFFICE 541.459.4545  
 FAX 541.459.4546  
[www.murphyplywood.com](http://www.murphyplywood.com)