

# 14010

70 Ton Tele-Boom Crawler Crane

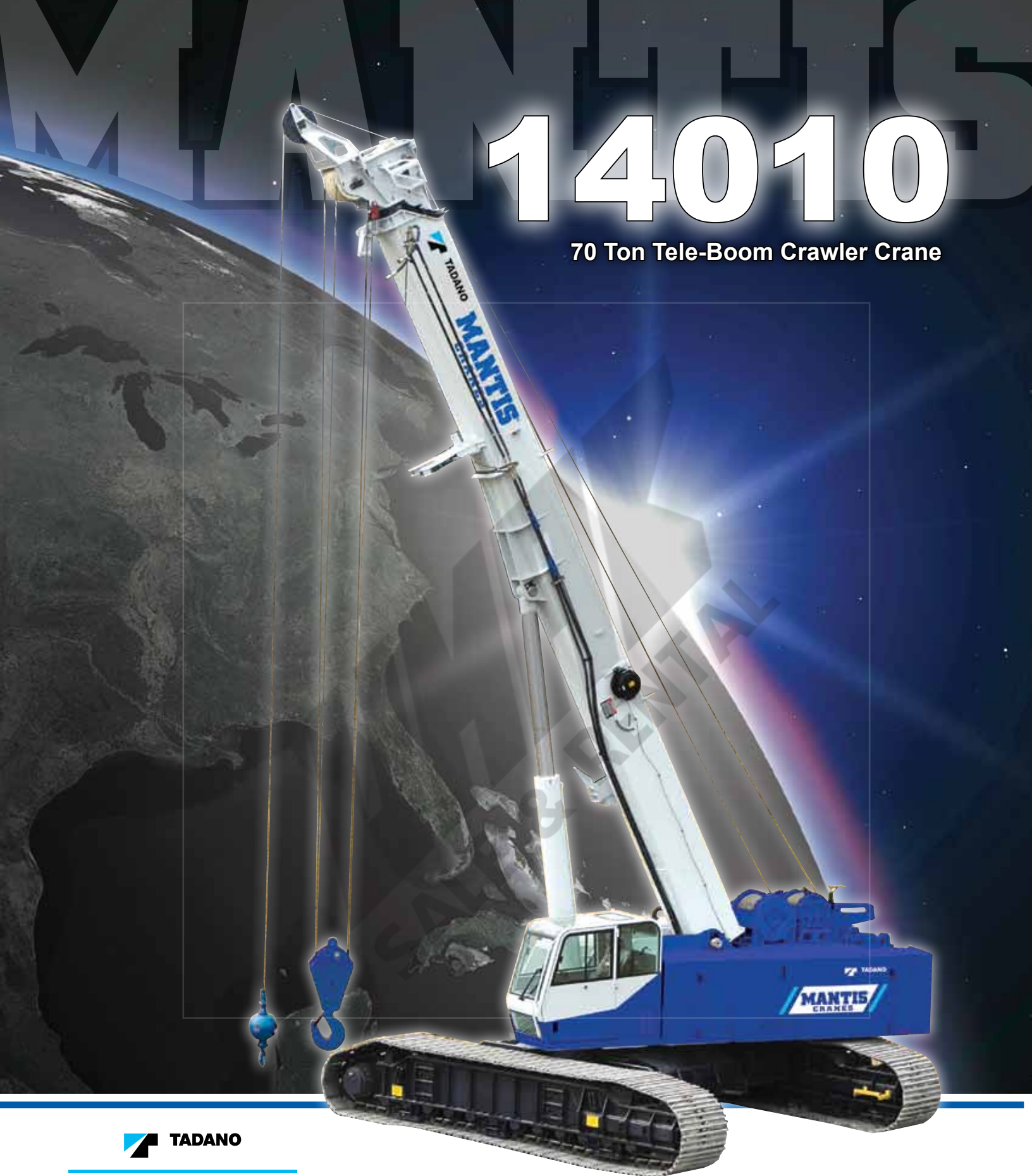

 TADANO

**MANTIS**<sup>®</sup>  
CRANES

[mantiscranes.com](http://mantiscranes.com)

### ACCESS WALKWAYS



### AUGER KIT AND POLE CLAW



### LIGHT BAR AND TOOL CIRCUIT



### WORK PLATFORM



# MANTIS<sup>®</sup> CRANES

## VERSATILE. POWERFUL. DEPENDABLE.

Tadano Mantis cranes are engineered as VERSATILE, heavy-duty machines. We match massive steel fabrications with diesel engines and state of the art hydraulics to provide a POWERFUL crane that meets the toughest demands in full load pick-and-carry as well as lift applications. MANTIS... the one DEPENDABLE crane that does it all on your jobsite



# FEATURES

## NO OTHER CRANE COMBINES SO MANY VALUABLE FEATURES:

- Pick-and-carry the full crane load chart through 360°.
- Lift and walk...even with tracks retracted.
- Climb steeper grades, thanks to minimized counterweight and low center of gravity.
- Pull through deep mud without bogging down.
- Telescope or lift the boom with a full load on the hook.
- Save time and money on the job due to low clearance height, retract on-the-fly tracks and telescopic boom.
- Independent hydrostatic track drives allow pivot turns and counter rotation
- Hydraulic tool circuit option powers wide choice of Mantis-approved tools.



Large access doors, spacious machinery compartments simplify preventative maintenance and service of the crane.



Conveniently positioned cameras display the winch as well as the blind area directly behind the crane. Full color video display in operator cab is standard equipment.



Spacious cab, adjustable seat, and conveniently located controls are common in all Tadano Mantis Cranes.



State-of-the-art, user friendly rated capacity limiter provides continuous feedback of crane lift and position data.

# SPECIFICATIONS

## MAXIMUM LIFTING CAPACITY

70 ton at 10 feet (63t at 3.0m)

## BOOM

4-section full power synchronized telescoping boom. Synchronized telescoping system consists of two double acting hydraulic cylinders with load holding valves and extension and retraction cables.

- Retracted Length: 37'6" (11.4m) • Extended Length: 111'6" (34 m)
- Extension Time: 102 s
- Elevating Angles: -1° to 78° • Elevating Time: 64 s
- Boom Head: Seven, 19 inch (483 mm) diameter cast nylon sheaves on heavy-duty roller bearings (5 load bearing and 2 lead in sheaves)
- Auxiliary Boom Head: Quick reeve, single 19 inch (483 mm) diameter high-strength, cast nylon sheave mounted on a heavy-duty roller bearing.
- Hook Block: 70 ton (63t) hook block – Five, 19 inch (483 mm) diameter sheaves mounted on heavy duty roller bearings with swivel hook and safety latch.
- Headache Ball: 12 ton (11t) ball includes a swivel hook with a safety latch.

## WINCHES

Planetary geared two-speed winch includes a bent axis hydraulic motor, multi-disc internal brake and counterbalance valve. Drum rotation indicator is included

- Main Winch
  - Rope Diameter and Length: 3/4" x 700 ft (19mm x 213m)
  - Single line pull: 17,960 LB (79.9 kN) (first layer)
  - Single line speed: 192 ft/min (59.0 m/min) (4th layer)
- Auxiliary Winch
  - Rope Diameter and Length: 3/4" x 350 ft (16mm x 107m)
  - Single line pull: 15,360 lb (69.3 kN) (first layer)
  - Single line speed: 243 ft/min (74.0 m/min) (at the 4th layer)

## TRAVEL

Each side frame contains a pilot controlled, two-speed track drive with hydraulic axial piston motor and parking brake. Travel system provides skid steering and counter rotation.

- Low travel speed: 0.8 mph (1.3 km/h)
- High travel speed : 1.2 mph (1.9 km/h)
- Gradeability (unladen): 46%

## LOAD MOMENT INDICATOR & ANTI -TWO BLOCK

Standard Rated Capacity Limiter and Anti-Two Block system

- Control function shutdown. Audible and visual warnings
- LCD screen provides a continuous display of working boom length, boom angle, working load radius, tip height, parts-of-line (operator set), machine track configuration (operator set), relative load moment, maximum permissible load and actual load.

## OPERATOR'S CAB

Fully-enclosed, air conditioned all-steel modular cab with lockable swinging door, acoustical lining, anti-slip floor and tinted safety glass.

- Rear view cameras are appropriately located as are three remote control work lights.
- 2-speed windshield wiper, top glass wiper
- Six-way adjustable fabric seat with headrest, seat belt
- Seat and armrest termination switches immediately disable all hydraulic functions as the operator rises from the seat or lifts the left hand armrest.

Dash instrumentation: tachometer, voltmeter, oil pressure gauge, temperature gauge, hour meter and fuel gauge. Indicators are provided for crane level, load moment, drum rotation, air filter restriction, hydraulic oil temperature and filter restriction, engine oil pressure and temperature.

## ENGINE

- Make/ Model: Cummins QSB 6.7 • Rating: 260 hp (194 kW) @ 2100 RPM
- Alternator: 130 amp

## ELECTRICAL SYSTEM

12VDC

## COUNTERWEIGHT

Total 30,000 lb (13,610 kg) rear counterweight (Two pieces)

## SWING

Gear motor driving a planetary gear reducer with a shaft mounted pinion, external gear shear ball slew bearing bolted to the superstructure and the carbody allows the superstructure to rotate 360°

- Swing Speed: 0 – 2.2 rpm
- Swing Parking Brake: Spring applied failsafe brake with hydraulic release that is controlled from the operators cab
- Swing Service Brake: Hydraulically applied, controlled through foot actuated pedal
- House Lock System: 2-position, manually pinned

## HYDRAULIC SYSTEM

- Hydraulic Pumps: Two high pressure, variable axial piston pumps with load sense and power limiting control for crane functions.
- Directional Valves: Multiple pressure and flow compensated valves with integrated relief valves controlled by hydraulic pilot signals.
- Pump output: 154 gpm (583 l/min) @ 2100 RPM engine speed. 4,800 psi (330 bar) maximum pressure
- Filtration: 5 micron.

## SIDE FRAMES

Two welded steel side frames are paired with a track group. The side frames extend and retract hydraulically and are controlled from the cab.

- Track Rollers: Two top and twelve bottom sealed rollers on each track frame Idler: Oil filled, self lubricating with spring type tensioner
- Track Shoes: 36 inch (900 mm) 3-bar semi grouser

## OPTIONAL EQUIPMENT

- Boom Extension: Lattice type, swing away
  - Length: 30 feet (9.1m)
  - Head: Two, 19-inch (483 mm) diameter cast nylon sheaves on heavy-duty roller bearings
  - Max. Lifting Height: 142 ft (43.3 m)
- Boom Jib: Lattice type, swing away, stores along boom extension
  - Length: 20 feet (6.1m) - Offset Angles: 15° & 30°
  - Max. Lifting Height: 162 feet (49.4 m)
- Track Shoes: 30 inch (760 mm) 3-bar semi grouser
- Track Shoes: 31.5 inch (800 mm) flat shoe
- Auger Ready Package: Includes hoses, fasteners and stowage bracket assembly mounted to the base section of the boom with a flow capability of 34 gpm (130 l/min)
- Complete Auger Package: Adds a two speed auger motor/gear box and one 60 inch (1.52 m) kelly bar to the Auger Ready Package.
- Tool Circuit: Provides 5 gpm (23 l/min) and 10 gpm (45 l/min) at 2,500 PSI (176 bar) through a 50 foot (15.2m) twin hose reel with quick disconnect fittings to operate open center tools.
- Free Fall Hoists: All winches are available in controlled free fall configurations.
- Cold Weather Packages: Cold weather options are available for operation to -40°C (Consult factory for application support)
- Work Platform: Model WP750 – 36 in x 72 in (0.9m x 1.8m) , all steel, welded, two person platform with maximum capacity of 750 lbs (340 kg).
- Pole Claw: Heavy-duty pole claw with hydraulic clamp and tilt.
- Radio control package.
- Rotation resistant wire rope.
- Access Walkways

# DIMENSIONS

# 14010

70 Ton Tele-Boom Crawler Crane

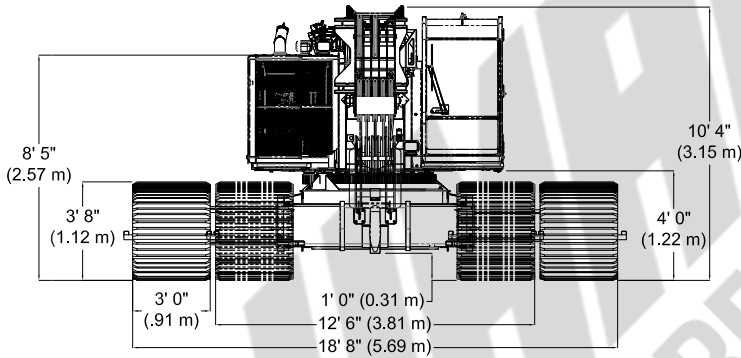
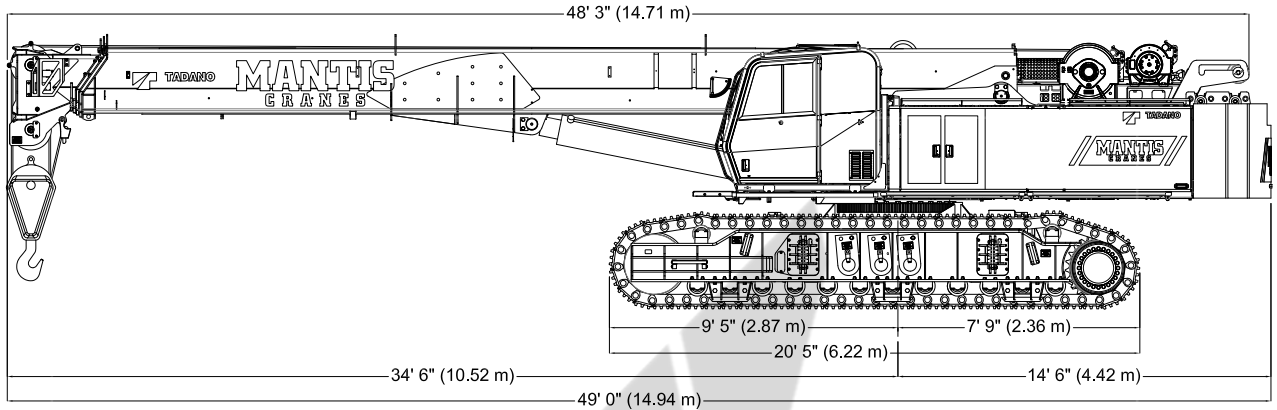

**111 FT 6 IN MAIN BOOM,  
30 FT EXTENSION & 20 FT JIB**

## WIDTHS, WEIGHTS, AND GROUND PRESSURES\*

Shoe Width	Overall Width		Area	Ground Pressure	Working Weight
	Retracted	Extended			
24 in (609 mm)	11 ft 6 in (3.51 m)	17 ft 8 in (5.39 m)	9,900 in <sup>2</sup> (6.38 m <sup>2</sup> )	13.0 psi (0.91 t/g/cm <sup>2</sup> )	128,490 lb (58,280 kg)
30 in (762 mm)	12 ft 0 in (3.66 m)	18 ft 2 in (5.54 m)	12,360 in <sup>2</sup> (7.97 m <sup>2</sup> )	10.5 psi (0.74 kg/cm <sup>2</sup> )	130,330 lb (59,120 kg)
36 in (900 mm)	12 ft 6 in (3.81 m)	18 ft 8 in (5.69 m)	14,850 in <sup>2</sup> (9.57 m <sup>2</sup> )	8.9 psi (0.63 kg/cm <sup>2</sup> )	132,154 lb (59,940 kg)

\*Crane equipped with: 111 ft 6 in boom, extension, jib, 70 ton hook block and 12 ton headache ball

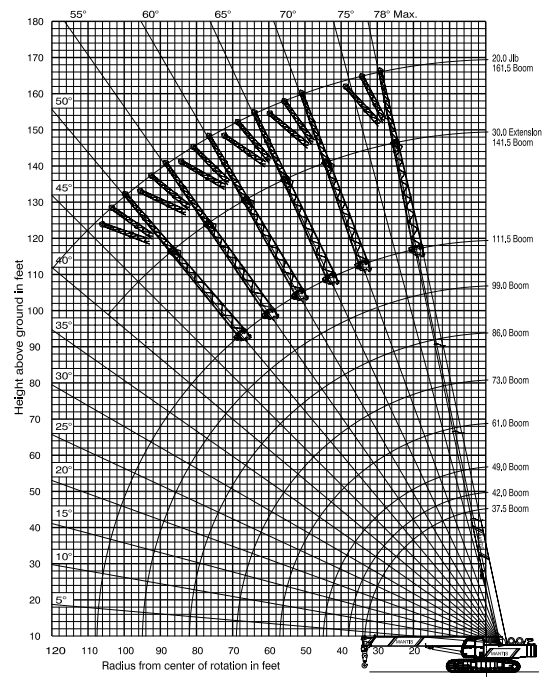

# TADANO MANTIS CORPORATION

1705 Columbia Avenue • Franklin, TN 37064 USA • Toll-Free: 1-800-272-3325 • Fax: 615-790-6803 • [mantiscranes.com](http://mantiscranes.com)



PICK AND CARRY



FOUNDATION



GENERAL CONSTRUCTION



ROAD AND BRIDGE



POWERLINE

### GENERAL DATA

<b>CRANE CAPACITY</b>	70 ton at 10 feet (63t at 3.0m)
<b>BOOM</b>	4-section, 37' 6" – 111' 6" (11.4 m – 34.0 m)
<b>DIMENSION</b>	
Overall Length	49' 0" (14.94 m)
Overall Width (tracks extended)	18' 8" (5.69 m)
Overall Width (tracks retracted)	12' 6" (3.81 m)
Overall Width (tracks removed)	10' 8" (3.25 m)
Overall Height	10' 4" (3.15 m)
<b>MASS</b>	
Gross Vehicle Mass (Standard Equipment Package)	132,154 LB (59,940 kg)
<b>PERFORMANCE</b>	
Travel Speed	0.8 mph – 1.2 mph (1.3 km/h – 2.1 km/h)
Gradability	46%

### CRANE SPECIFICATION

#### MODEL

14010

#### CAPACITY

70 ton at 10 feet (63t at 3.0m)

#### BOOM

4-section full power synchronized telescoping boom. Synchronized telescoping system consists of two double acting hydraulic cylinders with load holding valves and extension and retraction cables.

- Retracted Length: 37' 6" (11.4m)
- Extended Length: 111' 6" (34 m)      • Extension Time: 102 s
- Elevating Angles: -1° to 78°      • Elevating Time: 64 s
- Boom Head: Seven, 19 inch (483 mm) diameter cast nylon sheaves on heavy-duty roller bearings. (5 load bearing and 2 lead in sheaves)

#### AUXILIARY BOOM HEAD

Quick reeve, single 19 inch (483 mm) diameter high-strength, cast nylon sheave mounted on a heavy-duty roller bearing.

#### COUNTERWEIGHT

Total 30,000 LB (two pieces at 15,000 lbs each)  
13,610 kg (Two pieces at 6,805 kg each)

### WINCHES

Planetary geared two-speed winch includes a bent axis hydraulic motor, multi-disc internal brake and counterbalance valve. Drum rotation indicator is included (complete winch performance specs on Page 4)

- Main Winch
  - Rope Diameter and Length: ¾" x 700 ft (19mm x 213m)
  - Single line pull: 17,960 lb (79.9 kN)(first layer)
  - Single line speed: 192 ft/min (59 m/min)(4th layer)
- Auxiliary Winch
  - Rope Diameter and Length: ¾" x 350 ft (19mm x 107m)
  - Single line pull: 15,360 lb (69.3 kN) (first layer)
  - Single line speed: 243 ft/min (74.0 m/min) (at the 4th layer)

### TRAVEL

Each side frame contains a pilot controlled, two-speed track drive with hydraulic axial piston motor and parking brake. Travel system provides skid steering and counter rotation.

- Low travel speed: 0.8 mph (1.3 km/h)
- High travel speed : 1.2 mph (1.9 km/h)
- Gradeability (unladen): 46%

### SWING

Gear motor driving a planetary gear reducer with a shaft mounted pinion, external gear shear ball slew bearing bolted to the superstructure and the carbody allows the superstructure to rotate 360°

- Swing Speed: 0 – 2.2 rpm
- Swing Parking Brake: Spring applied failsafe brake with hydraulic release that is controlled from the operators cab
- Swing Service Brake: Hydraulically applied, controlled through foot actuated pedal
- House Lock System: 2-position, manually pinned

### LOAD MOMENT INDICATOR

Standard Rated Capacity Limiter and Anti-Two Block system

- Control function shutdown. Audible and visual warnings
- LCD screen provides a continuous display of working boom length, boom angle, working load radius, tip height, parts-of-line (operator set), machine track configuration, relative load moment, maximum permissible load and actual load.
- Anti-two block weight allows quick reeving of hook block

### FRAME

The frame is an all-steel, welded structure, precision machined to accept attachment of the boom and swing components.

**OPERATORS CAB**

Fully-enclosed, air conditioned all-steel modular cab with lockable swinging door, acoustical lining, anti-slip floor and tinted safety glass.

- Rear view cameras are appropriately located as are three remote control work lights.
- Vent window in the rear of the cab.
- Grab bars and steps are located for easy access to the cab.
- Defroster, heater, circulating fan
- 2-speed windshield wiper, top glass wiper
- Six-way adjustable fabric seat with headrest, seat belt
- Dome light
- Dry-chemical fire extinguisher
- Four-way electronic armrest mounted joysticks control swing, boom extend, main winch, auxiliary winch and boom hoist. Electronic foot pedals control the travel and swing service brake functions.
- Selectable control modes for: Fine Control, Auger, and hand control of travel functions.
- Seat and armrest termination switches immediately disable all hydraulic functions as the operator rises from the seat or lifts the left hand armrest.

Dash instrumentation: tachometer, voltmeter, oil pressure gauge, temperature gauge, hour meter and fuel gauge. Indicators are provided for crane level, load moment, drum rotation, air filter restriction, hydraulic oil temperature and filter restriction, engine oil pressure and temperature.

**ENGINE**

- Make/ Model: Cummins QSB 6.7
- Type: 6 Cylinder, Water cooled, 4 Cycle
- Aspiration: Turbocharged and Aftercooled
- Max.Output: 260 hp (194 kw) @ 2200 RPM
- Max Torque: 728 Lb-ft (987 Nm) @ 1500 RPM
- Piston Disp: 6.7 liter
- Bore x Stroke: 107mm x 124mm
- Emission Cert: U.S. EPA Tier 3, Euromot Stage IIIA
- Alternator: 130 amp

**ELECTRICAL SYSTEM**

12 VDC

**FUEL SYSTEM**

- Capacity: 100 gallon (378 liter)
- Filtration: Inline fuel/water separator and engine mounted fuel filter

**SIDE FRAMES**

Two welded steel side frames are paired with a track group. The side frames extend and retract hydraulically and are controlled from the cab.

- Track Rollers: Two top and twelve bottom sealed rollers on each track frame Idler: Oil filled, self lubricating with spring type tensioner
- Track Shoes: 36 inch (900 mm), 3-bar semi grouser

**HYDRAULIC SYSTEM**

- Hydraulic Pumps: Two high pressure, variable axial piston pumps with load sense and power limiting control for crane functions. One variable axial piston pump for cooling loop
- Directional Valves: Multiple pressure and flow compensated valves with integrated relief valves controlled by hydraulic pilot signals.
- Pump output: 154 gpm (583 l/min) @ 2100 RPM engine speed. 4,800 psi (330 bar) maximum pressure
- Reservoir: 300 gallon (1,136 liter) capacity, spin-on filler/ breather, sight gauge, cleanout, and sump drain.
- Filtration: 5 micron, full flow tank mounted return filters with electrical clogging indicator. 5 micron pilot oil in-line pressure filter
- Diagnostic Ports: Provided for system, load sense, and pilot pressure

**OPTIONAL EQUIPMENT**

- Boom Extension: Lattice type, swing away
  - Length: 30 feet (9.1m)
  - Head: Two, 19-inch (483 mm) diameter cast nylon sheaves on heavy-duty roller bearings
  - Max. Lifting Height: 142 ft (43.3 m)
- Boom Jib: Lattice type, swing away, stores along boom extension
  - Length: 20 feet (6.1m)
  - Offset Angles: 15° & 30°
  - Max. Lifting Height: 162 feet (49.4 m)
- Track Shoes: 30 inch (760 mm) 3-bar semi grouser
- Track Shoes: 31.5 inch (800 mm) flat shoe
- Auger Ready Package: Includes hoses, fasteners and stowage bracket assembly mounted to the base section of the boom with a flow capability of 34 gpm (130 l/min)
- Complete Auger Package: Adds a two speed auger motor/gear box and one 60 inch (1.52 m) kelly bar to the Auger Ready Package.
- Tool Circuit: Provides 5 gpm (23 l/min) and 10 gpm (45 l/min) at 2,500 PSI (176 bar) through a 50 foot (15.2m) twin hose reel with quick disconnect fittings to operate open center tools.
- Free Fall Hoists: All winches are available in controlled free fall configurations.
- Cold Weather Packages: Cold weather options are available for operation to -40°C (Consult factory for application support)
- Work Platform: Model WP750 – 36 in x 72 in (0.9m x 1.8m) , all steel, welded, two person platform with maximum capacity of 750 lbs (340 kg).
- Pole Claw: Heavy-duty pole claw with hydraulic clamp and tilt.
- Access walkways
- Radio control package.
- Rotation resistant wire rope.
- Hook Block: 70 ton (63 t) hook block - Five 19 inch (483 mm) diameter sheaves mounted on heavy duty roller bearings with swivel hook and safety latch.
- Headache Ball: 12 ton (11t) ball includes a swivel hook with a safety latch



## MAIN WINCH

Planetary geared two-speed winch includes a bent axis, variable displacement hydraulic motor and a multi-disc internal brake.  
Wire Rope: 700 ft (213 m) 3/4 in (19 mm) 6 x 37 EIPS, IWRC, RRL. Line pulls are not based on wire rope strength. Drum rotation indicator is standard.

Rope Layer	Maximum Line Pull		Full Load Line Speed		High Line Speed		Layer		Total	
	lb	kN	ft/min	m/min	ft/min	m/min	ft	m	ft	m
1	17,960	79.9	149	45	336	102	109	33	109	33
2	16,400	72.9	164	50	368	112	119	36	228	69
3	15,090	67.1	178	54	400	122	130	40	358	109
4	13,970	62.1	192	59	432	132	140	43	498	152
5	13,010	57.9	206	63	464	141	153	46	649	198
6	12,170	54.1	221	67	496	151	161	49	810	247

## AUXILIARY WINCH

Planetary geared two-speed winch includes a bent axis, variable displacement hydraulic motor and a multi-disc internal brake.  
Wire Rope: 350 ft (107 m) 3/4 in (19 mm) 6 x 37 EIPS, IWRC, RRL. Line pulls are not based on wire rope strength. Drum rotation indicator is standard.

Rope Layer	Maximum Line Pull		Full Load Line Speed		High Line Speed		Layer		Total	
	lb	kN	ft/min	m/min	ft/min	m/min	ft	m	ft	m
1	15,360	68.3	175	53	392	119	64	20	64	20
2	13,590	60.5	197	60	444	135	72	21	136	41
3	12,180	54.2	220	67	495	151	80	25	216	66
4	11,040	49.1	243	74	546	166	89	27	305	93
5	10,100	44.9	266	81	597	182	97	30	402	123

## MACHINE WEIGHTS

LB

KG

Standard Crane with 4 Section 111 Ft 6 in (34.0 m) Boom, Auxiliary Winch, 70 Ton Hook Block, 12 Ton Headache Ball, 2 Piece Counterweight & 36 in (914 mm) Track Shoes	132,154	59,940
Crane Less Counterweight and Track Frames	62,150	28,122
Counterweight, 2 Pieces at 15,500 Lb each	30,000	13,610
Track Frames, 2 pieces at 18,000 LB each	36,000	16,290
Auxiliary Winch with standard rope	960	434

## OPTIONAL EQUIPMENT

LB

KG

Alternative Boom 54 ft (16.46 m) three section boom in place of standard boom**	-8,300	-3,756
70 ton Hook Block	1,600	726
12 ton Headache Ball	404	183
30 ft (9.1m) Lattice Extension	1,700	769
20 ft (6.1m) Jib	700	317
Auxiliary Nose Sheave	210	95
Auger Ready Package	440	199
Complete Auger Package	1,520	688
60 in Kelly Bar	120	54
72 in Kelly Bar	140	63
Heavy Duty Pole Claw	830	375

\*\* Deduction from Standard Crane Weight

# 14010

70 Ton Telescopic Boom Crawler Crane

SPECIFICATION SHEET NO. 473-01/11

## DIMENSIONS

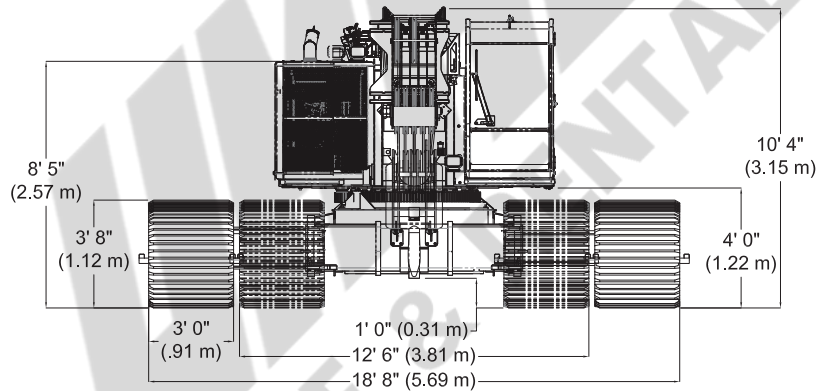
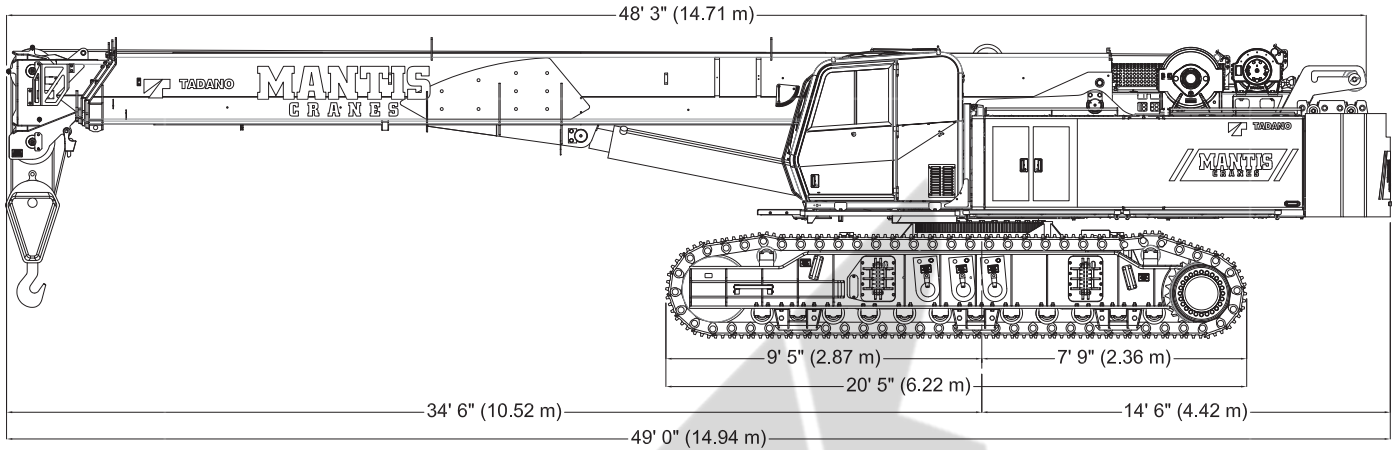

### WIDTHS, WEIGHTS, AND GROUND PRESSURES\*

Shoe Width	Overall Width		Area	Ground Pressure	Working Weight
	Retracted	Extended			
24 in (609 mm)	11 ft 6 in (3.51 m)	17 ft 8 in (5.39 m)	9,900 in <sup>2</sup> (6.38 m <sup>2</sup> )	13.0 psi (0.91 kg/cm <sup>2</sup> )	128,490 lb (58,280 kg)
30 in (762 mm)	12 ft 0 in (3.66 m)	18 ft 2 in (5.54 m)	12,360 in <sup>2</sup> (7.97 m <sup>2</sup> )	10.5 psi (0.74 kg/cm <sup>2</sup> )	130,330 lb (59,120 kg)
36 in (900 mm)	12 ft 6 in (3.81 m)	18 ft 8 in (5.69 m)	14,850 in <sup>2</sup> (9.57 m <sup>2</sup> )	8.9 psi (0.63 kg/cm <sup>2</sup> )	132,154 lb (59,940 kg)

\* Crane equipped with: 111 ft 6 in boom, extension, jib, 70 ton hook block and 12 ton headache ball

111 FT 6 IN MAIN BOOM, 30 FT EXTENSION & 20 FT JIB

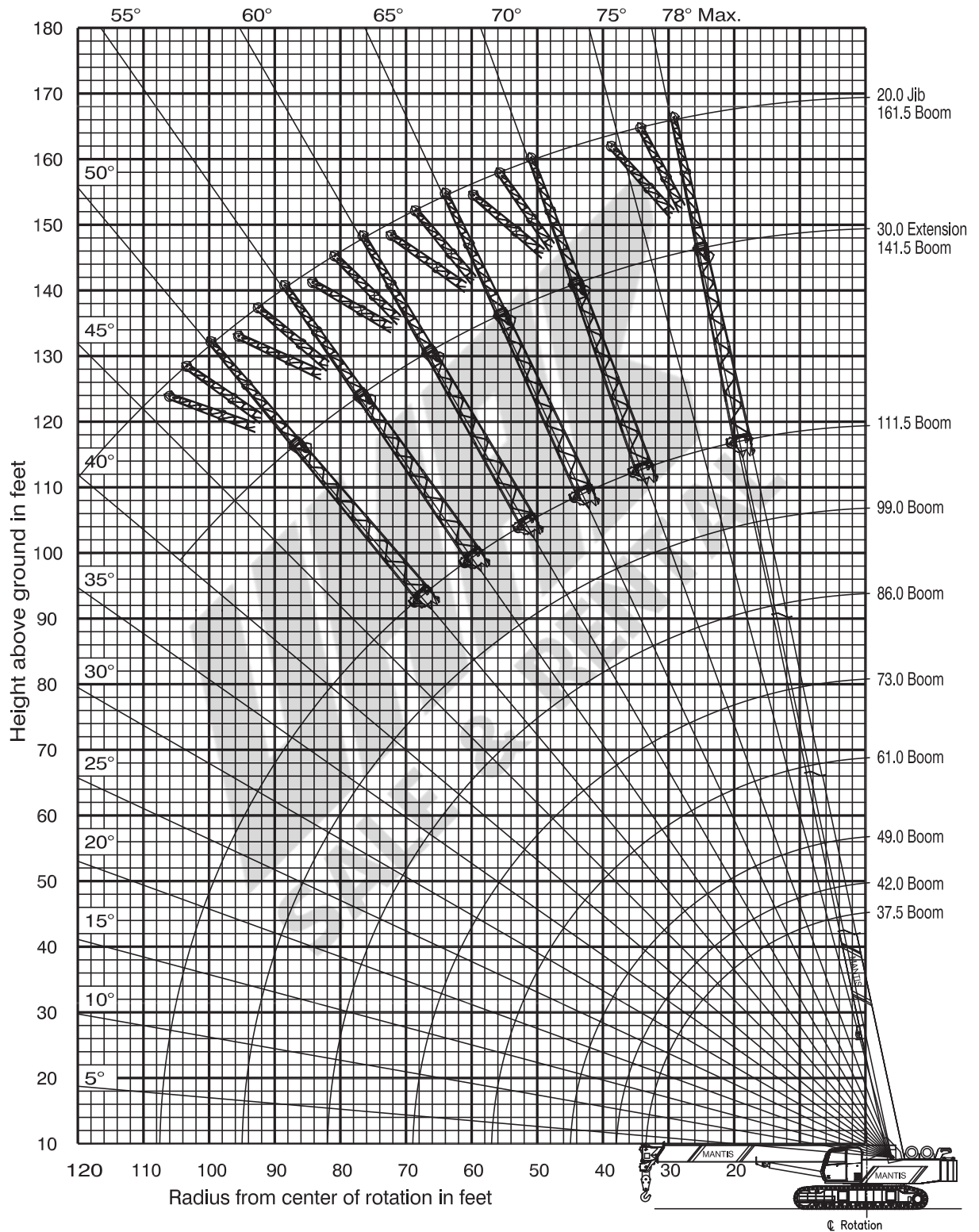

CAUTION: THESE CHART VALUES ARE ONLY A GUIDE AND MUST NOT BE USED TO OPERATE THE CRANE.  
USE ONLY THE IN CAB LOAD CHARTS AND OPERATORS MANUAL FURNISHED WITH THE CRANE.



## LOAD CHARTS

### 360 DEGREE RATING - LOADS IN lb x 1000

MAIN BOOM with TRACKS FULLY RETRACTED			
30,000 lb COUNTERWEIGHT			
RADIUS (ft)	MAIN BOOM LENGTH (ft)	MAIN BOOM LENGTH (ft)	RADIUS (ft)
	37.5 to 61.0	61.0 to 111.5	
15	70.6	44.0	15
20	46.7	38.4	20
25	33.5	33.5	25
30	24.5	24.5	30
35	19.2	19.2	35
40	15.8	15.8	40
45	13.2	13.2	45
50	10.7	10.7	50
55	8.8	8.8	55
60	7.2	7.2	60
65	6.0	6.0	65
70	5.0	5.0	70

30' EXTENSION & 20' JIB with TRACKS FULLY EXTENDED								
30' EXTENSION					20' JIB			Boom Angle
Boom Angle	30,000 lb COUNTERWEIGHT		15,000 lb COUNTERWEIGHT		30,000 lb or 15,000 lb COUNTERWEIGHT			
	Total Boom Length (ft)		Total Boom Length (ft)		Jib Offset Angles			
	67.5 to 129	> 129.0	67.5 to 103.0	> 103.0	0°	15°	30°	
78°	18.0	18.0	18.0	18.0	6.6	4.0	2.2	78°
75°	13.6	13.6	13.6	13.6	6.3	4.0	2.1	75°
72°	11.5	11.5	11.5	11.5	5.6	3.5	2.0	72°
70°	10.1	10.1	10.1	10.1	5.1	3.2	1.9	70°
68°	8.9	8.9	8.9	8.9	4.6	3.0	1.8	68°
65°	8.0	8.0	8.0	8.0	4.2	2.8	1.8	65°
62°	7.2	7.2	7.2	6.3	3.9	2.6	1.7	62°
60°	6.7	6.7	6.7	5.4	3.5	2.4	1.7	60°
58°	6.1	6.1	6.1	4.5	3.2	1.9	1.4	58°
55°	5.8	5.8	5.8	3.6	2.6	1.3	1.0	55°
52°	5.3	5.3	5.3	2.8	2.0	0.6	0.4	52°
50°	5.1	5.1	5.1	2.3	1.5	0.3	0.2	50°
48°	4.9	4.6	4.9	1.9				48°
45°	4.6	4.0	4.6	1.4				45°

WEIGHT REDUCTIONS LOAD HANDLING DEVICES	
HOOKBLOCK: 70 Ton - 5 Sheave	1600 lbs
OVERHAUL BALL: 12 Ton w/Swivel	404 lbs
OPTIONAL HANDLING DEVICES	
30 ft. Extension - Stowed**	350 lbs
30 ft. Extension - Erected**	2000 lbs
30 ft. Ext. and 20 ft. Jib - Stowed**	750 lbs
30 ft. Ext. and 20 ft. Jib - Erected**	3500 lbs
Auxillary Nose Sheave**	250 lbs

\*\* Reduction of main boom capacities.

ZERO DEGREE BOOM ANGLE MAXIMUM CAPACITY with TRACKS FULLY EXTENDED 30,000 lb COUNTERWEIGHT			
BOOM LENGTH (ft)	RADIUS (ft)	LOAD (lbs) (x 1000)	BOOM LENGTH (ft)
<b>37.5</b>	33.5	30.6	<b>37.5</b>
<b>42.0</b>	38.0	24.3	<b>42.0</b>
<b>49.0</b>	45.0	20.9	<b>49.0</b>
<b>61.0</b>	57.0	11.5	<b>61.0</b>
<b>73.0</b>	69.0	8.2	<b>73.0</b>
<b>86.0</b>	82.0	7.0	<b>86.0</b>
<b>99.0</b>	95.0	4.9	<b>99.0</b>
<b>111.5</b>	107.5	4.1	<b>111.5</b>

NOTE: Capacities appearing above the bold line are based on structural strength; tipping should not be relied upon as a capacity limitation. Capacities appearing below the bold line are based on stability and do not exceed 75% of tipping.

CAUTION: THESE CHART VALUES ARE ONLY A GUIDE AND MUST NOT BE USED TO OPERATE THE CRANE.  
USE ONLY THE IN CAB LOAD CHARTS AND OPERATORS MANUAL FURNISHED WITH THE CRANE.

## LOAD CHARTS

### 360 DEGREE RATING - LOADS IN lb x 1000

AUXILIARY NOSE SHEAVE with TRACKS FULLY EXTENDED																										
RADIUS (ft)	30,000 lb COUNTERWEIGHT								15,000 lb COUNTERWEIGHT								ZERO COUNTERWEIGHT								RADIUS (ft)	
	MAIN BOOM LENGTH (ft)								MAIN BOOM LENGTH (ft)								MAIN BOOM LENGTH (ft)									
	37.5	42.0	49.0	61.0	73.0	86.0	99.0	111.5	37.5	42.0	49.0	61.0	73.0	86.0	99.0	111.5	37.5	42.0	49.0	61.0	73.0	86.0	99.0	111.5		
10	11.0	11.0	11.0	11.0*					11.0	11.0	11.0	11.0*						11.0	11.0	11.0	11.0*					10
	70.1°	70.1°	70.1°	70.1°					70.1°	70.1°	70.1°	70.1°						70.1°	70.1°	70.1°	70.1°					
12	11.0	11.0	11.0	11.0*					11.0	11.0	11.0	11.0*						11.0	11.0	11.0	11.0*					12
	66.8°	69.4°	72.5°	76.0°					66.8°	69.4°	72.5°	76.0°						66.8°	69.4°	72.5°	76.0°					
15	11.0	11.0	11.0	11.0	11.0	11.0*			11.0	11.0	11.0	11.0	11.0	11.0*				11.0	11.0	11.0	11.0	11.0	11.0*			15
	61.6°	64.9°	68.7°	73.1°	75.9°	78.1°			61.6°	64.9°	68.7°	73.1°	75.9°	78.1°				61.6°	64.9°	68.7°	73.1°	75.9°	78.1°			
20	11.0	11.0	11.0	11.0	11.0	11.0	11.0*		11.0	11.0	11.0	11.0	11.0	11.0	11.0*			11.0	11.0	11.0	11.0	11.0	11.0	11.0*		20
	52.2°	57.0°	62.2°	68.1°	71.8°	74.7°	76.7°		52.2°	57.0°	62.2°	68.1°	71.8°	74.7°	76.7°			52.2°	57.0°	62.2°	68.1°	71.8°	74.7°	76.7°		
25	11.0	11.0	11.0	11.0	11.0	11.0	11.0	11.0*	11.0	11.0	11.0	11.0	11.0	11.0	11.0	11.0*									25	
	41.4°	48.2°	55.3°	62.9°	67.6°	71.2°	73.7°	75.6°	41.4°	48.2°	55.3°	62.9°	67.6°	71.2°	73.7°	75.6°	41.4°	48.2°	55.3°	62.9°	67.6°	71.2°	73.7°	75.6°		
30	11.0	11.0	11.0	11.0	11.0	11.0	11.0	11.0	11.0	11.0	11.0	11.0	11.0	11.0	11.0	11.0									30	
	27.0°	37.8°	47.6°	57.4°	63.3°	67.6°	70.7°	72.9°	27.0°	37.8°	47.6°	57.4°	63.3°	67.6°	70.7°	72.9°	27.0°	37.8°	47.6°	57.4°	63.3°	67.6°	70.7°	72.9°		
35	11.0	11.0	11.0	11.0	11.0	11.0	11.0	11.0	11.0	11.0	11.0	11.0	11.0	11.0	11.0	11.0									35	
	23.7°	38.8°	51.5°	58.7°	63.9°	67.6°	70.2°		23.7°	38.8°	51.5°	58.7°	63.9°	67.6°	70.2°		23.7°	38.8°	51.5°	58.7°	63.9°	67.6°	70.2°			
40			11.0	11.0	11.0	11.0	11.0	11.0			11.0	11.0	11.0	11.0	11.0	11.0			9.3	8.7	9.6	10.4	10.9	11.0	40	
			27.7°	45.1°	54.0°	60.1°	64.4°	67.4°			27.7°	45.1°	54.0°	60.1°	64.4°	67.4°			27.7°	45.1°	54.0°	60.1°	64.4°	67.4°		
45			11.0	11.0	11.0	11.0	11.0	11.0			11.0	11.0	11.0	11.0	11.0	11.0			6.4	7.3	8.0	8.5	8.9		45	
			3.1°	37.8°	48.9°	56.1°	61.1°	64.6°			3.1°	37.8°	48.9°	56.1°	61.1°	64.6°			37.8°	48.9°	56.1°	61.1°	64.6°			
50				11.0	11.0	11.0	11.0	11.0				9.8	10.7	11.0	11.0	11.0			4.7	5.6	6.2	6.7	7.1		50	
				29.0°	43.3°	52.0°	57.7°	61.7°				29.0°	43.3°	52.0°	57.7°	61.7°			29.0°	43.3°	52.0°	57.7°	61.7°			
55				11.0	11.0	11.0	11.0	11.0				7.9	8.7	9.4	9.9	10.2			3.3	4.2	4.8	5.3	5.6		55	
				16.0°	37.1°	47.6°	54.2°	58.7°				16.0°	37.1°	47.6°	54.2°	58.7°			16.0°	37.1°	47.6°	54.2°	58.7°			
60					11.0	11.0	11.0	11.0					7.2	7.8	8.3	8.6					3.0	3.7	4.2	4.5	60	
					29.8°	42.8°	50.5°	55.7°					29.8°	42.8°	50.5°	55.7°					29.8°	42.8°	50.5°	55.7°		
65					9.8	9.9	10.0	10.1					5.9	6.5	7.0	7.3					2.1	2.8	3.2	3.5	65	
					20.1°	37.5°	46.6°	52.4°					20.1°	37.5°	46.6°	52.4°					20.1°	37.5°	46.6°	52.4°		
70						8.1	8.2	8.4						5.4	5.9	6.2						2.0	2.4	2.7	70	
						31.5°	42.4°	49.1°						31.5°	42.4°	49.1°						31.5°	42.4°	49.1°		
75						7.3	7.4	7.5						4.5	5.0	5.3						1.3	1.7	2.1	75	
						24.2°	37.8°	45.6°						24.2°	37.8°	45.6°						24.2°	37.8°	45.6°		
80						6.6	6.7	6.9						3.7	4.1	4.5						0.7	1.2	1.5	80	
						13.3°	32.7°	41.8°						13.3°	32.7°	41.8°						13.3°	32.7°	41.8°		
85							6.3	6.4							3.5	3.8							0.7	1.0	85	
							26.7°	37.7°							26.7°	37.7°							26.7°	37.7°		
90							5.6	5.7							2.8	3.2							NR	0.5	90	
							19.1°	33.2°							19.1°	33.2°							NR	33.2°		
95							4.9	5.2							2.3	2.6							NR	NR	95	
							1.5°	28.1°							1.5°	28.1°							NR	NR		
100								4.6								2.1								NR	100	
								21.8°								21.8°							NR	NR		
105								4.0								1.7								NR	105	
								12.9°								12.9°							NR	NR		

NOTE: Capacities appearing above the bold line are based on structural strength; tipping should not be relied upon as a capacity limitation.  
Capacities appearing below the bold line are based on stability and do not exceed 75% of tipping.

CAUTION: THESE CHART VALUES ARE ONLY A GUIDE AND MUST NOT BE USED TO OPERATE THE CRANE.  
USE ONLY THE IN CAB LOAD CHARTS AND OPERATORS MANUAL FURNISHED WITH THE CRANE.

## LOAD CHARTS

**750 WORK PLATFORM**  
**Installed on MANTIS MODEL 15010**  
**as originally manufactured and equipped by Tadano Mantis Corporation**

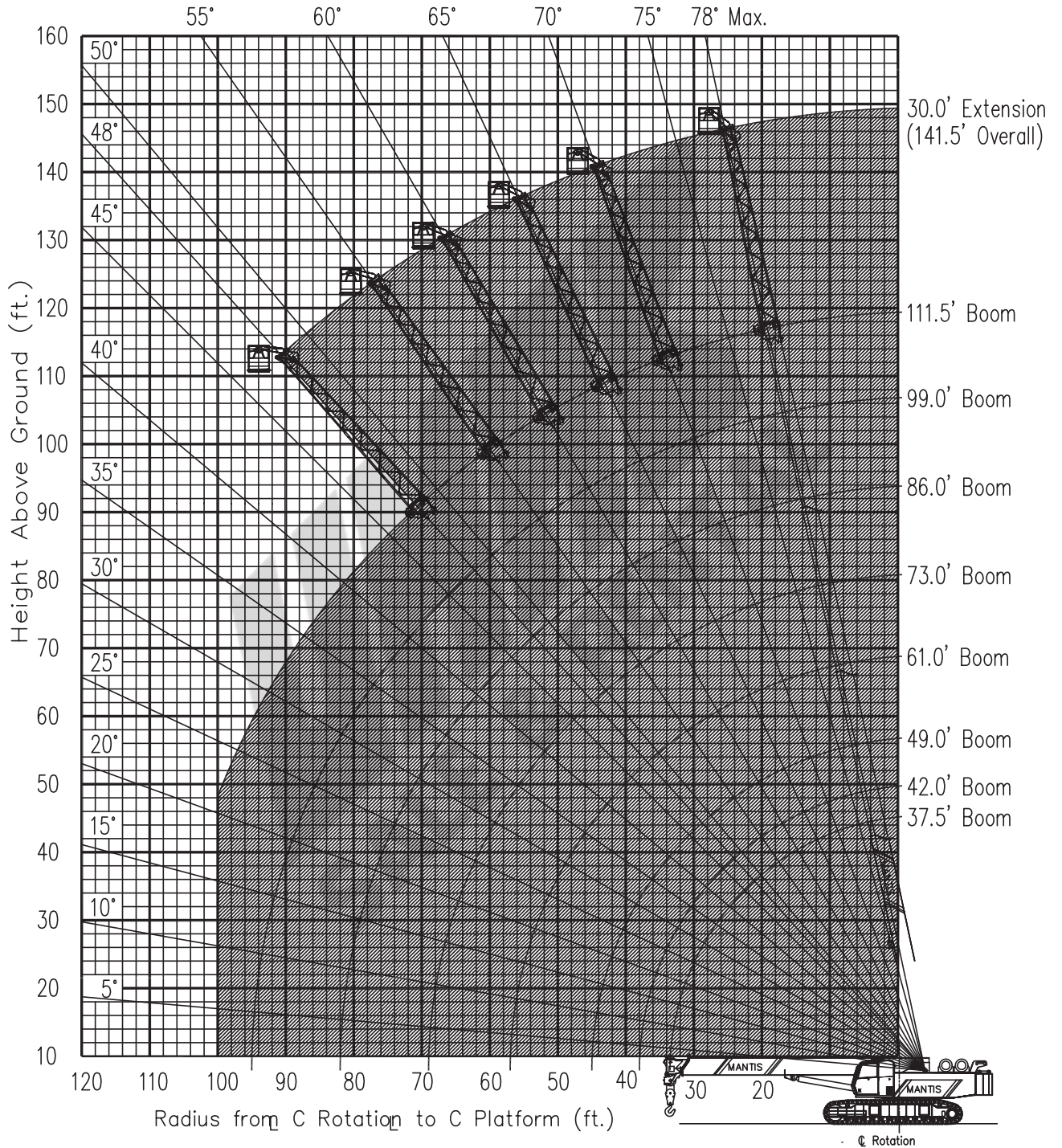

Limits of operation: Maximum load capacity = 750 lb      Maximum radius when mounted on main boom = 100 ft

**CAUTION: THESE CHART VALUES ARE ONLY A GUIDE AND MUST NOT BE USED TO OPERATE THE CRANE.**  
 USE ONLY THE IN CAB LOAD CHARTS AND OPERATORS MANUAL FURNISHED WITH THE CRANE.

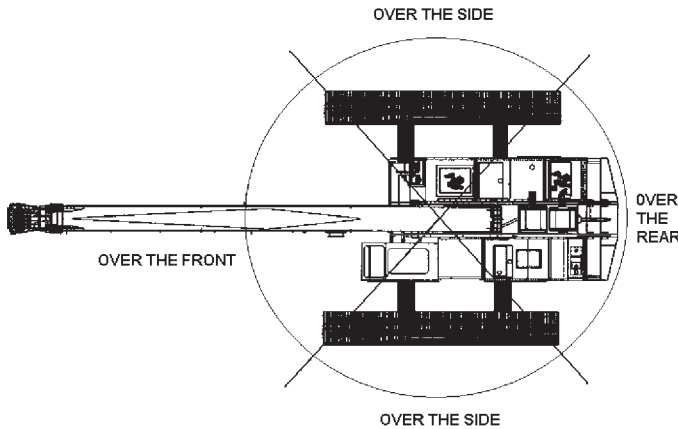

TADANO MANTIS 14010				
WIRE ROPE LINE PULL CAPACITIES				
PARTS OF LINE	MAIN WINCH (LB)	AUX WINCH (LB)	PARTS OF LINE	MAIN WINCH (LB)
1	16,800	15,360	6	95,713
2	32,859	30,105	7	110,850
3	48,925	N/A	8	125,764
4	64,754	N/A	9	140,457
5	80,348	N/A	10	154,933

3/4 inch (19 mm) diameter wire rope, 6x37 Class, EIP, IWRC

**PLEASE READ, UNDERSTAND, AND FOLLOW THE MANUALS FURNISHED WITH THE CRANE (OPERATORS AND SAFETY) AS WELL AS THE CAPACITY LIMITATIONS AND GENERAL CONDITIONS LISTED BELOW PRIOR TO OPERATION OF THE CRANE. FAILURE TO DO SO MAY RESULT IN AN ACCIDENT.**

This **MANTIS CRANE** as manufactured by Tadano Mantis Corporation meets the requirements of **ASME B30.5**. Structure and stability have been tested in accordance with **SAE J1063** and **SAE J765**, respectively. Lifting capacities as determined by boom length, angle or radius, apply only to machines as originally equipped by manufacturer and in a properly maintained condition. Capacities given are maximum covered by the manufacturer's warranty and are based on a freely suspended load with **NO** allowance for factors as out-of-level operation, supporting surface conditions, hazardous surroundings, experience of personnel, etc. The operator shall establish practical working loads based on prevailing operating conditions, such as, but not limited to the above.

When making lifts where capacities may be within a zone limited by structural strength, the operator shall determine that the weight of the load is known within plus or minus (+/-) ten percent (10%) before making lift. **DO NOT** lift load or extend boom without counterweight in place. Deductions from rated capacities must be made for the weight of the hook block, hook/ball, slings, spreader bar, or other suspended equipment.

Side pull on boom is extremely dangerous and must be avoided.

**DO NOT** exceed manufacturer's maximum specified reeving.

**DO NOT** use this chart if wind speed exceeds 20 mph. Consult the manufacturer for specialized load ratings.

Load radius is defined as the horizontal distance from the axis of rotation (with no load) to the center of the lifting device after load is applied. Boom angle is the included angle between the longitudinal axis of the boom base section and the Horizontal axis, after lifting load. The boom angle before lifting should be slightly greater than desired to account for boom deflection.

Boom angle/boom length relationships given are an approximation of the resulted load radius, which should be an accurate measurement. Boom height dimensions are measured from ground to center of lower boom head sheave.

It is permissible to attempt to telescope boom with a load within the limits of rated capacities. However, boom angle system hydraulic pressure, and/or boom lubrication may affect operation.

It is permissible to travel with loads within the rated capacity of the crane. Travel speeds should be greatly reduced to reflect terrain limitations and minimize dynamic loads applied to the crane structure.

CAUTION: THESE CHART VALUES ARE ONLY A GUIDE AND MUST NOT BE USED TO OPERATE THE CRANE. USE ONLY THE IN CAB LOAD CHARTS AND OPERATORS MANUAL FURNISHED WITH THE CRANE.





# TADANO MANTIS CORPORATION

1705 Columbia Avenue • Franklin, TN 37064 USA • Toll-Free: 1-800-272-3325 • Fax: 615-790-6803 • [mantiscranes.com](http://mantiscranes.com)



## MANTIS® 14010 70 TON TELE-BOOM CRAWLER CRANE

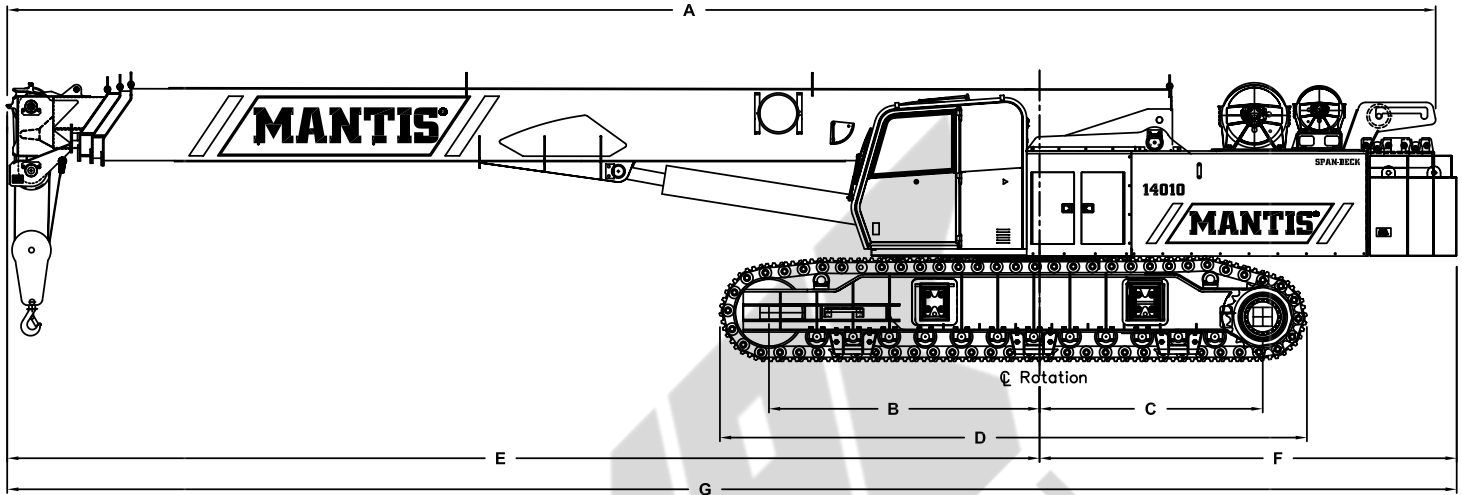

### PRINCIPAL DIMENSIONS

A	Length (Counterweight Removed)	48 ft 3 in (14.71 m)
B	CL Front Track Drive to CL Rotation	9 ft 5 in (2.87 m)
C	CL Rear Track Drive to CL Rotation	7 ft 9 in (2.36 m)
D	Track Length	20 ft 5 in (6.22 m)
E	Boom Length to CL Rotation	34 ft 6 in (10.52 m)
F	Tailswing	14 ft 6 in (4.42 m)
G	Overall Length	49 ft 0 in (14.94 m)
H	Ground to Top of Engine Cover	8 ft 5 in (2.57 m)
I	Track Height	44 in (1.12 m)
J	Ground Clearance	12 in (305 mm)
K	Ground to Bottom of Cab	48 in (1.22 m)
L	Maximum Overall Height	10 ft 4 in (3.15 m)
M	Track Width	36 in (900 mm)
N	Overall Width (Tracks Retracted)	12 ft 6 in (3.81 m)
O	Overall Working Width	18 ft 8 in (5.69 m)

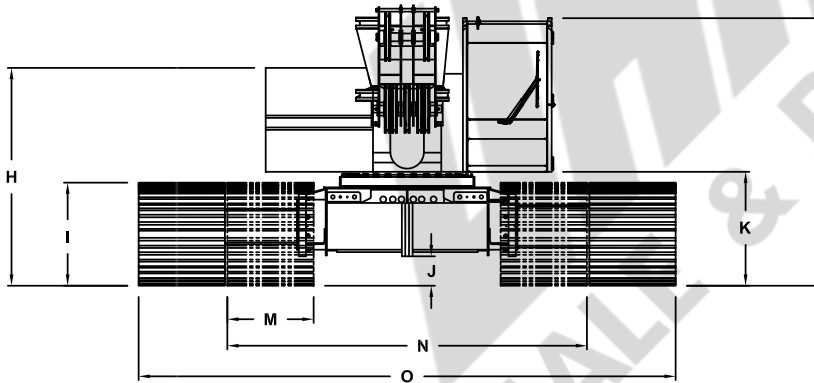

### WIDTHS, WEIGHTS, AND GROUND PRESSURES\*

Shoe Width	Overall Width		Area	Ground Pressure	Working Weight
	Retracted	Extended			
24 in (609 mm)	11 ft 6 in (3.51 m)	17 ft 8 in (5.39 m)	9,900 in <sup>2</sup> (6.38 m <sup>2</sup> )	13.0 psi (0.91 kg/cm <sup>2</sup> )	128,490 lb (58,280 kg)
30 in (762 mm)	12 ft 0 in (3.66 m)	18 ft 2 in (5.54 m)	12,360 in <sup>2</sup> (7.97 m <sup>2</sup> )	10.5 psi (0.74 kg/cm <sup>2</sup> )	130,330 lb (59,120 kg)
36 in (900 mm)	12 ft 6 in (3.81 m)	18 ft 8 in (5.69 m)	14,850 in <sup>2</sup> (9.57 m <sup>2</sup> )	8.9 psi (0.63 kg/cm <sup>2</sup> )	132,154 lb (59,940 kg)

\* Crane equipped with: 111 ft 6 in boom, extension, jib, 70 ton hook block and 12 ton headache ball



# SPECIFICATIONS

## MANTIS® 14010 70 TON TELE-BOOM CRAWLER CRANE

### STANDARD CRANE AND EQUIPMENT

---

#### Boom

The boom consists of four full powered sections, 37 ft 6 in (11.43 m) retracted to 111 ft 6 in (33.99 m) fully extended. Maximum tip height is 117 ft (35.66 m).

#### Boom Telescoping & Elevating Systems

The telescoping system features two double-acting hydraulic cylinders and counterbalance lock valves. The elevating system features a cylinder and counterbalance lock valve which provide boom elevations from -1° to 78°.

#### Boom Head

Seven 19 in (483 mm) diameter, cast nylon sheaves on heavy-duty roller bearings are mounted in the boom head.

### SUPERSTRUCTURE

---

#### Frame

The frame is an all-steel, welded structure, precision machined to accept attachment of the boom and swing components.

#### Operator's Cab

The fully-enclosed, air conditioned all-steel modular cab includes a lockable swinging door, acoustical lining, anti-slip floor and tinted safety glass. Sliding windows are located in the cab door and cab boom side. A vent window is positioned in the rear of the cab. Grab bars and steps are appropriately located for easy access to the cab. Erectable swing barricades are attached to the superstructure. Rear view cameras are appropriately located as are work lights.

Standard cab accessories include a two-speed windshield wiper, top glass wiper, defroster, heater, circulating fan, adjustable hand and foot throttles, six-way adjustable fabric seat with headrest, seat belt, dome light, and a dry-chemical fire extinguisher.

#### Instrumentation

Dash instrumentation features a tachometer, voltmeter, oil pressure gauge, temperature gauge, hour meter and fuel gauge. Indicators are provided for crane level, load moment, drum rotation, air filter restriction, hydraulic oil temperature and filter restriction, engine oil pressure and temperature.

A termination switch is located in the seat and armrest and is capable of immediately disabling all hydraulic functions as the operator rises from the seat or it can be activated by lifting the left hand armrest.

#### Control

Two-way hydraulic joysticks mounted in the operator's seat armrests control swing, auxiliary hoist, main winch and boom hoist. Four two-way hydraulic foot pedals control travel, swing service brake and boom telescoping functions. Travel pedal hand levers are available as an option. A fifth pedal controls engine speed.

#### Counterweight

The 30,000 lb (13,610 kg) counterweight system consists of two 15,000 lb (6,805 kg) pieces. Each can be removed and installed via a pendant attached to the boom.

#### Load Moment Indicator & Anti-Two Block<sup>1</sup>

Standard Rated Capacity Limiter and Anti-Two Block system with audio-visual warning and control function shutdown. System's LCD screen provides a continuous electronic display of working boom length, boom angle, working load radius, tip height, parts-of-line (operator set), machine configuration, relative load moment, maximum permissible load and actual load.

The standard Work Area Definition system allows the operator to pre-set and define working areas. Should pre-set limits be approached, audio-visual warnings aid the operator in avoiding job-site obstructions. The anti-two block weight allows quick reeving of hook blocks.

#### Swing

The superstructure rotates 360° around a shear ball slew bearing with an external gear that matches with the swing drive pinion and bolts to the superstructure and the carbody. The hydraulic swing drive powers the system and consists of a gear motor driving into a planetary reducer with a shaft mounted pinion providing infinitely variable speeds of up to 3 rpm.

Swing braking is achieved through a "failsafe", hydraulically released, spring applied, multi-disc wet brake which includes a foot applied service brake. The brake can be electrically actuated through a cab mounted switch into a "locked-on" (parking) mode. A two position house lock system is included. Regular lubrication of the bearing is achieved through a cab mounted grease applicator.

#### Fuel System

A 100 US gal (378 l) tank is bolted to the superstructure. The fuel filtration system consists of an inline fuel/water separator as well as an engine mounted fuel filter.

#### Hydraulic System

The load sensing, open-loop hydraulic system is served by two variable volume pumps mounted in tandem. The pumps are horsepower limiting and pressure compensated providing a maximum output of 168 gpm (636 l/min) @ 2,200 rpm and maximum operating pressure of 4,850 psi (339.5 kg/cm<sup>2</sup>). An extra circuit is included for ready adaptation to hydraulic accessories.

The system includes two pilot operated valve banks that are pressure and flow compensated. The 300 US gal (1,136 l) capacity hydraulic oil reservoir has a spin-on filler-breather cap, external sight gauge, clean-out access and a sump type drain. An air to oil remote mounted cooler provides oil cooling with thermostatically-controlled, electrically driven fans. Hydraulic oil filtering is achieved with two 5 micron full flow cartridge type filters designed to return in-tank with bypass protection and an electronic bypass indicator.

(System pressure test ports with quick disconnect fittings are provided for diagnostics.)

## 70 TON TELE-BOOM CRAWLER CRANE

### MAIN HOIST

Planetary geared two-speed winch includes a bent axis, variable displacement hydraulic motor and a multi-disc internal brake.										
Rope Layer	Maximum Line Pull		Full Load Line Speed		Pitch Diameter		Layer		Total	
1	21,400 lb	9,707 kg	158 ft/min	48 m/min	16.8 in	425.4 mm	109.0 ft	33.2 m	109.0 ft	33.2 m
2	19,540 lb	8,863 kg	173 ft/min	53 m/min	18.1 in	459.4 mm	203.0 ft	62.0 m	228.0 ft	69.5 m
3	17,970 lb	8,151 kg	188 ft/min	57 m/min	19.4 in	493.4 mm	220.0 ft	67.0 m	358.0 ft	109.0 m
4	16,640 lb	7,548 kg	204 ft/min	62 m/min	20.8 in	527.4 mm	237.0 ft	72.0 m	498.0 ft	152.0 m
5	15,490 lb	7,026 kg	219 ft/min	67 m/min	22.1 in	561.3 mm	253.0 ft	77.0 m	649.0 ft	198.0 m
6	14,500 lb	6,577 kg	234 ft/min	71 m/min	23.4 in	595.3 mm	270.0 ft	82.0 m	810.0 ft	247.0 m

### AUXILIARY HOIST

Planetary geared two-speed winch includes a bent axis, variable displacement hydraulic motor and a multi-disc internal brake. Wire Rope: 350 ft (107 m) 3/4" (19 mm) 6 x 37 EIPS, IWRC, RRL. Line pulls are not based on wire rope strength. Drum rotation indicator is standard.										
Rope Layer	Maximum Line Pull		Full Load Line Speed		Pitch Diameter		Layer		Total	
1	17,500 lb	7,940 kg	180 ft/min	54.9 m/min	11.5 in	292.1 mm	64.0 ft	19.6 m	64.0 ft	19.6 m
2	15,400 lb	6,990 kg	197 ft/min	60.0 m/min	12.8 in	326.1 mm	72.0 ft	21.9 m	136.0 ft	41.4 m
3	13,800 lb	6,260 kg	208 ft/min	63.4 m/min	14.2 in	360.0 mm	79.0 ft	24.1 m	215.0 ft	65.6 m
4	12,500 lb	5,670 kg	219 ft/min	66.8 m/min	15.5 in	394.0 mm	87.0 ft	26.4 m	302.0 ft	92.0 m
5	11,500 lb	5,220 kg	235 ft/min	71.6 m/min	16.8 in	428.0 mm	94.0 ft	28.7 m	396.0 ft	120.6 m

### STANDARD ENGINE

Cummins QSB240 (U.S. EPA Tier 3)					
Noise Emissions: Top 96.3 dBA (excludes noise from intake, exhaust, cooling system and driven components)					
Type	6 Cylinder Water Cooled	Weight (Wet)	1056 lb (479 kg)	Aspiration	Turbocharged & Aftercooled
Displacement	360 cu in (5.9 l)	Oil Capacity	17.2 US quarts (16.3 l)	Air filter	Dry Type
Bore	4.02 in (102 mm)	Rated Horsepower	240 (179 kw) @ 2200 rpm	Electrical	12 volt
Stroke	4.72 in (120 mm)	Peak Torque	652 ft-lb (884 Nm) @ 1500 rpm	Alternator	100 amp

### MACHINE WEIGHTS

STANDARD CRANE WITH 4 SECTION 111 ft 6 in (33.99 m) BOOM, 2 PIECE COUNTERWEIGHT & 36 in (914 mm) TRACK SHOES	127,750 lb	57,950 kg
Crane Less Counterweights and Track Frames	61,300 lb	27,810 kg
Counterweight, 2 pieces 15,000 lb (6,805 kg) each	30,000 lb	13,610 kg
Track Frames, 2 pieces 18,000 lb (8,165 kg) each	36,000 lb	16,330 kg
OPTIONAL EQUIPMENT		
Alternative Boom 54 ft (16.46 m) three section boom in place of standard boom**	(8,300) lb	(3,760) kg
Alternative Boom 40 ft (12.19 m) two section boom in place of standard boom**	(11,900) lb	(5,400) kg
30 ft (9.14 m) Lattice Extension	1,700 lb	771 kg
20 ft (6.10 m) Jib (connects to head of Lattice Extension ONLY)	700 lb	318 kg
Auxiliary Winch with Standard Rope	962 lb	436 kg
Auxiliary Nose Sheave	210 lb	95 kg
12 ton (11 mt) Headache Ball	404 lb	200 kg
70 ton (64 mt) Hook Block	1,600 lb	726 kg
Auger Ready Package	440 lb	200 kg
Complete Auger Package	1,520 lb	690 kg
60 in (1.52 m) Auger Kelly Bar	120 lb	54 kg
72 in (1.83 m) Auger Kelly Bar	140 lb	64 kg

## 70 TON TELE-BOOM CRAWLER CRANE

### UNDERCARRIAGE

#### Carbody

The welded steel, box type carbody is fabricated with square axles to accept the crawler side frames. The top surface is precision machined to receive the swing bearing.

#### Side Frames

Two welded steel removable side frames are paired with a track group consisting of twelve bottom and two top oil-filled & sealed rollers. Each frame includes an oil-filled, self-lubricating idler and spring type, track tensioning device. Standard track shoes are 36 in (900 mm) wide, 3-bar semi-grousers. Optional shoes are available in 30 in (762 mm) width flat pad and semi-grouser configuration; 36 in flat pads are also available. The side frames extend and retract hydraulically and are electrically controlled from the cab.

### OPTIONAL EQUIPMENT

#### Booms

- **Three Section Boom:** hydraulically proportional full power boom, 26 ft (7.93 m) retracted to 54 ft (16.46 m) extended, maximum tip height of 55 ft 8 in (17.27 m).
- **Two Section Boom:** hydraulically proportional full power boom, 26 ft (7.93 m) retracted to 40 ft (12.19 m) extended, maximum tip height of 47 ft 10 in (14.58 m).

#### Boom Attachments

- **Boom Extension:** 30 ft (9.14 m) lattice type swingaway, stores alongside of the boom base section and used with or without the optional 20 ft (6.10 m) jib. Head contains two 19 in (483 mm) diameter high strength cast nylon sheaves mounted on heavy-duty roller bearings, reeving up to 2 parts of wire rope, with optional extension deployed maximum tip height is 147 ft (44.81 m).
- **Boom Jib:** 20 ft (6.10 m) lattice type swingaway, attaches to and stores alongside the extension and can only be used with the extension deployed. Offsets are at 15° & 30°; with optional jib and extension deployed maximum tip height is 167 ft (50.90 m).
- **Auxiliary Nose Sheave:** quick reeve, single 19 in (483 mm) diameter high-strength, cast nylon sheave mounted on a heavy-duty roller bearing boom tip adapter.
- **Wire Rope:** rotation resistant, (non-spin) Dyform-18 HSLR.
- **Headache Ball:** 12 ton (11 mt) ball includes a swivel hook with safety latch.
- **Hook Block:** 70 ton (63 mt) hook block consists of five 19 in (483 mm) diameter sheaves mounted on heavy-duty roller bearings with a swivel hook and safety latch.

#### Travel

Each side frame contains a pilot controlled, two-speed track drive. The drives are hydraulic piston motors which propel the crane at a low speed of 1.5 mph (2.4 km/hr) and at a high speed of 2.5 mph (4.0 km/hr). The internal brake system is spring applied and automatically released upon actuation of the travel system.

The hydraulic travel system provides skid steering and track counter rotation and achieves an unladen gradeability of 46%.

#### Hydraulic

- **Auxiliary Hoist:** planetary geared two-speed winch includes a bent axis, variable displacement hydraulic motor and a multi-disc internal brake.
- **Auger Ready Package:** includes hoses, fasteners and stowage bracket assembly mounted to the base section of the boom with a flow capability of 34 gpm (130 l/min).
- **Complete Auger Package:** adds a two speed auger motor/gear box and one 60 in (1.52 m) kelly bar to the Auger Ready Package.
- **Tool Circuit:** provides 6 gpm (23 l/min) and 12 gpm (45 l/min) at 2,500 psi (176 kg/cm<sup>2</sup>) through a 50 ft (15.24 m) twin hose reel with quick disconnect fittings to operate open center tools.

#### Other Options

- **Free Fall Hoists:** all winches are available in free fall and controlled free fall configurations.
- **Crane Cab Access Walkways:** a pair of 54.5 in (1 384 mm) wide x 25 in (635 mm) deep walkways which attach to both the front and rear of the carbody and allow for easier egress and ingress to the operator's cab when the crane's upper rotating frame is not aligned front to rear.
- **Model WP750 Work Platform:** 36 in x 72 in (914 mm x 1 828 mm), all-steel, welded, two-person platform with a maximum capacity of 750 lb (340 kg). A test weight and boom head adapter are included in the package. Operation and control are by the crane operator from the cab. Radio (RF) controls to enable remote operation from the platform are available.

(See separate WP750 Specification for a complete description of standard and optional Work Platform equipment.)

\*Load moment indicating and anti-two block systems are operator aids and must never be used in lieu of job site lift planning calculations by the operator which must take into account ground conditions, weather and all other environmental factors prevailing at the time of the lift. Prices and specifications are subject to change at any time without prior notice and are for factory installation at time of original manufacture. F.O.B Plant; Richlands, VA 24641. Illustrations and photographs may show optional equipment. Supercedes all previous issues. Please see [www.mantiscranes.com](http://www.mantiscranes.com) for most current information.