

Hurd Window Installation Instructions for Nail Fin & Wood Brick Mould Units

Nail Fin Windows See Pages 2-11

Wood Brick Mould Windows See Pages 2-6, 8 & 12BM - 14BM
Installation Instructions
for All Window Shapes

See Page 12 for Flashing Application on Special Shaped Windows

Important: Thoroughly read and follow these instructions. Failure to install as recommended may void any warranty obligations of Hurd, whether express or implied. **Check building codes for the area in which the windows are being installed before installation to insure proper compliance.**

Hurd Windows & Doors, Inc., recommends utilizing an InstallationMasters™ Certified Installer or an experienced, qualified professional contractor who practices InstallationMasters™ installation methods to provide for proper operation and a proper flashing to the building. Contact your Hurd Distributor for further information. These installation procedures are general guidelines for standard wood frame construction; other methods can be utilized at the discretion of the architect or installer.

Hurd Windows & Doors, Inc., is not responsible for the completeness or quality of installation.

Nailing fins DO NOT take the place of standard window flashing. Windows must be properly flashed to provide a tight seal.

See Home Owner Care and Maintenance brochure for proper care and up-keep of unit.

The installer is responsible for proper installation guidelines in accordance with any local/state codes and or ordinances.

Please Note for Units Needing to Meet a DP Rating:

For units that have to meet a specific DP (Design Pressure) rating, any kind of building wrap must be folded and taped away from each rough opening before the unit is installed. Unit must come in contact with the building's bare sheathing. Once unit is installed and flashed properly, the building wrap must be untaped and trimmed flush with the unit's exterior. A bead of sealant must be placed along the seam joint of the building wrap and the unit. Tape the corner cuts in the building wrap as shown in illustration (K) on page 11. Please follow all other methods of installation as shown in this brochure.

©2007 Part# 098567 Printed in the U.S.A Hurd Windows & Doors, Inc.

Hurd Windows & Doors, Inc. is not responsible for completeness or quality of NON-factory assembled frames.

Hurd Windows & Doors, Inc. is not responsible for installation.

Information utilized from the InstallationMasters™ Training Manual Method A1 in this instruction, as identified, is re-printed with permission from InstallationMasters™Institute.

Products With Synthetic Stucco

Serious concerns have been raised about excessive moisture problems in homes and other buildings that have *Exterior Insulation Finish Systems, commonly referred to as EIFS or Synthetic Stucco*.

Many experts agree that a certain amount of water or moisture can be expected to enter almost any building exterior system. The building system should allow such water and moisture to escape or weep to the exterior, so no damage occurs. However, some EIFS systems may not allow water or moisture that penetrates the wall system to weep to the exterior. This can cause excessive moisture to accumulate within the wall system, which can cause serious damage to wall and other building components. It has been reported that this barrier, EIFS systems, are particularly prone to this problem.

Moisture problems in any type of building structure can be reduced by proper design and construction with appropriate moisture control considerations, taking into account prevailing climate conditions. Examples of moisture control considerations include flashing and/or sealing of all building exterior penetration points, use of appropriate materials and construction techniques, adherence to applicable building codes, and general attention to proper design and workmanship of the entire building system, including allowances for management of moisture within the wall system.

Determination of proper building design, components and construction, including moisture management, are the responsibility of the design architect, the contractors, and the manufacturer of the exterior wall finish products. Questions and concerns about moisture management issues should be taken up with these professionals. Hurd Windows & Doors, Inc., is not responsible for problems or damages caused by deficiencies in building design, construction or maintenance, failure to install our products properly, or use of our products in systems that do not allow for proper management of moisture within the wall system.

Expansion Joint Between Unit & Exterior Coverings

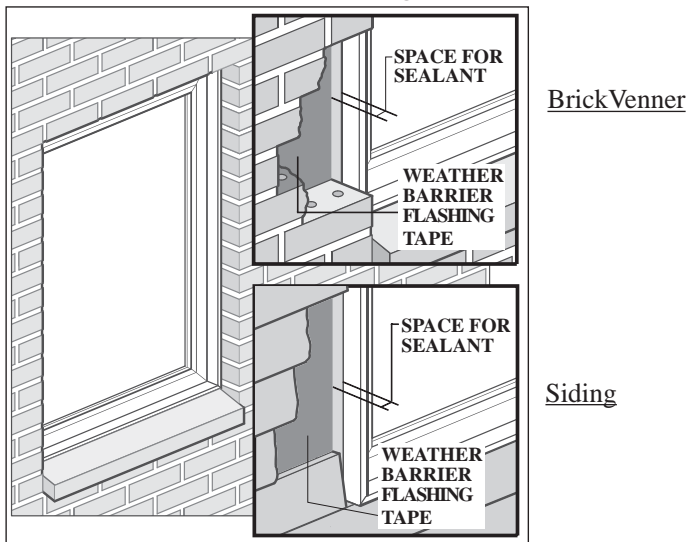

The perimeter joint between window exterior and the exterior building material must conform to siding manufacturers' recommendations. All masonry, stucco, or synthetic stucco systems require an expansion joint around the window perimeter that must be filled with sealant compatible with the building material and door components.

Expansion joint space should be no less than 3/8" and not greater than 1/2" unless stated otherwise by your siding manufacturer. If there is a conflict, follow siding manufacturer's guidelines.

Failure of this joint will cause structural damage unrelated to window performance.

DANGER



CUT HAZARD

- *Non-safety glass.
- *May cause serious injuries if broken.
- *Do not install where tempered safety glass is required.

WARNING

Weight of door unit(s) and accessories will vary. Use a reasonable number of people with sufficient strength to lift, carry and install window or door unit(s) and accessories. Always consider site conditions and use appropriate techniques when installing.

DANGER



Screen will not stop children, any one or anything from falling out window or door.

Keep children and objects away from open windows or doors.

DANGER

Falling from window or door opening may result in serious injury or death. DO NOT leave openings unattended when children are present.

3

All Window Installation Instruction

Hurd
Windows and Doors

Hurd Window Installation Instructions-Rough Opening Plumb, Levelness & Squareness

Check size (Width and Height), plumb, levelness and squareness of the rough opening. Remove packaging materials and installation accessories from the window units and inspect for damages and shortages. Inform your distributor of any damages or shortages. **IMPORTANT:** Check/measure the unit size and make sure each window will fit its designated rough opening, and that the rough opening is square. Check opening for size & squareness, by placing a square at each corner. Make all necessary adjustments to ensure rough opening is plumb, level and square.

Opening should allow a minimum of 1/4" shim space at head, sill and jambs. Sill must be flat, level and capable of supporting the weight of the window unit. All window units must remain closed & locked during installation.

Check Rough Opening for Plumb, Levelness & Squareness.

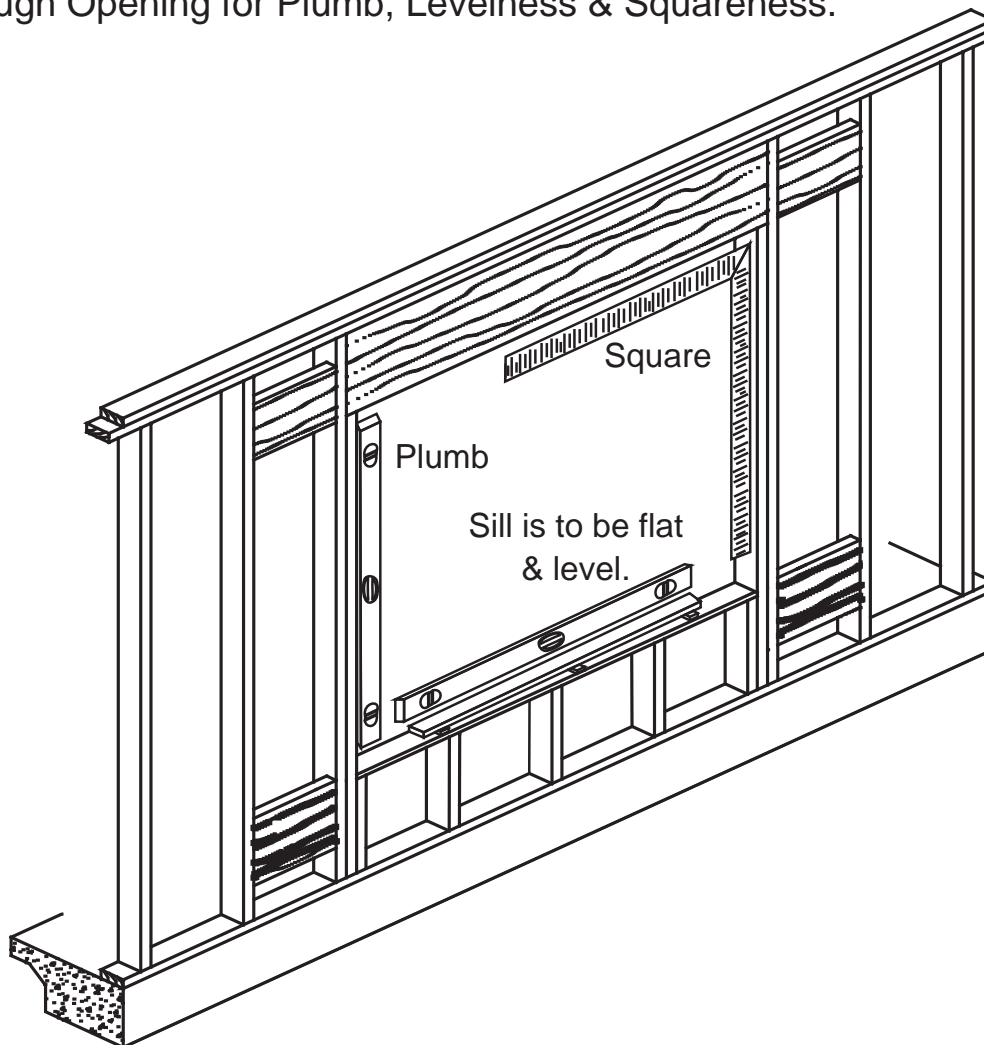

4

All Window Installation Instruction

Hurd
Windows and Doors

Hurd Window Installation Instructions - Building Wrap

When the building wrap covers the window opening make a modified I-Cut as shown in (A). Fold bottom and side flaps over and behind the interior sides of the rough framing as shown in (B). Attach and trim to the interior as shown in (B) at sill and jambs.

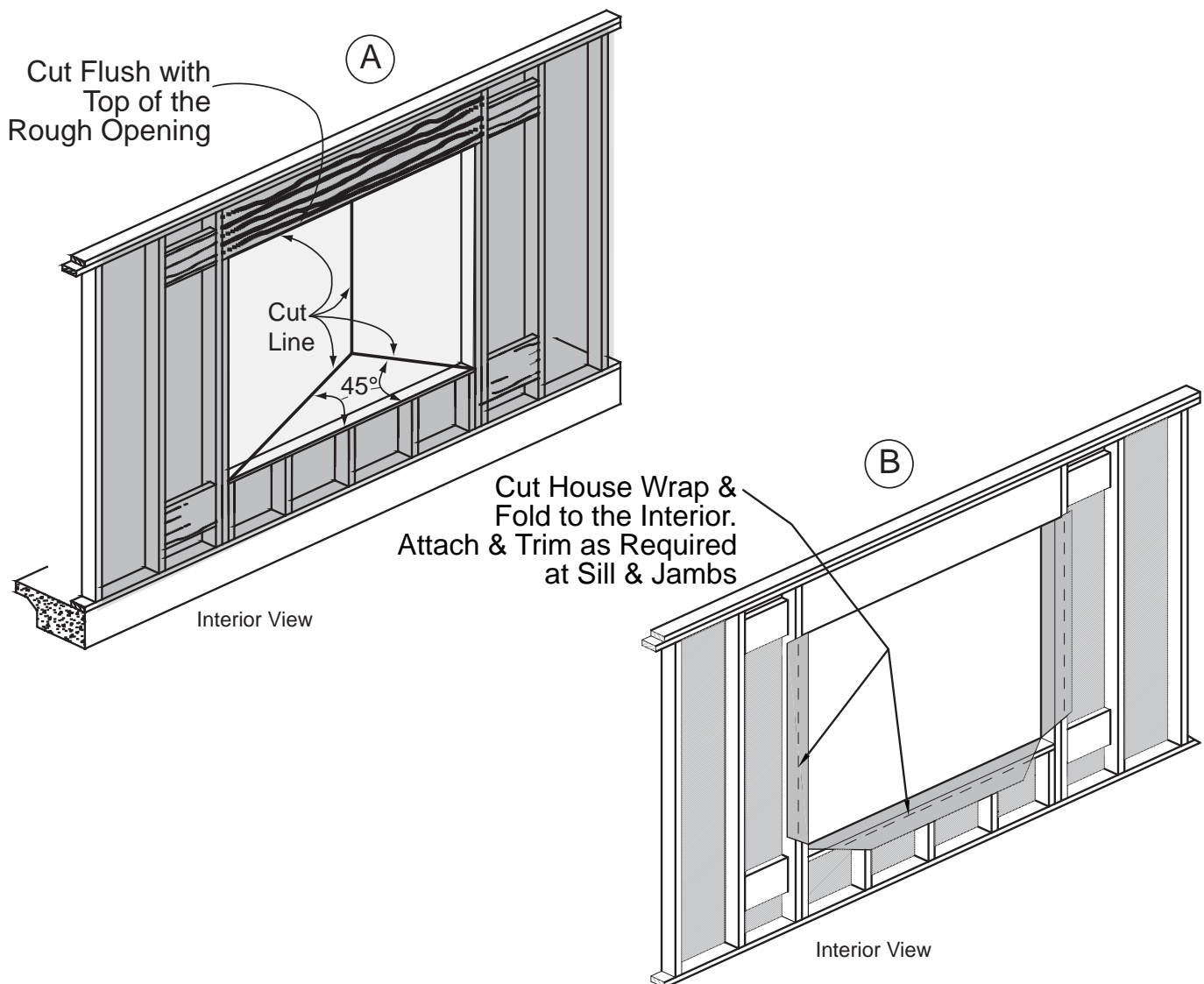

5

All Window Installation Instruction

Hurd
Windows and Doors

Hurd Window Installation Instructions with Nail Fin - Tape Building Wrap Up at Head

Measure for diagonal cuts at top of window corners for both building paper or building wrap as shown below in (C).

- Measure from the corner 9" up and 9" over and mark (45° diagonal).
- Cut on the diagonal from marked point to the rough opening corner.
- Measure and cut the other upper corner.

Carefully raise the top edge of the building wrap and tape the corners and center to the barrier surface above. This will allow for later installation of the window and flashing.

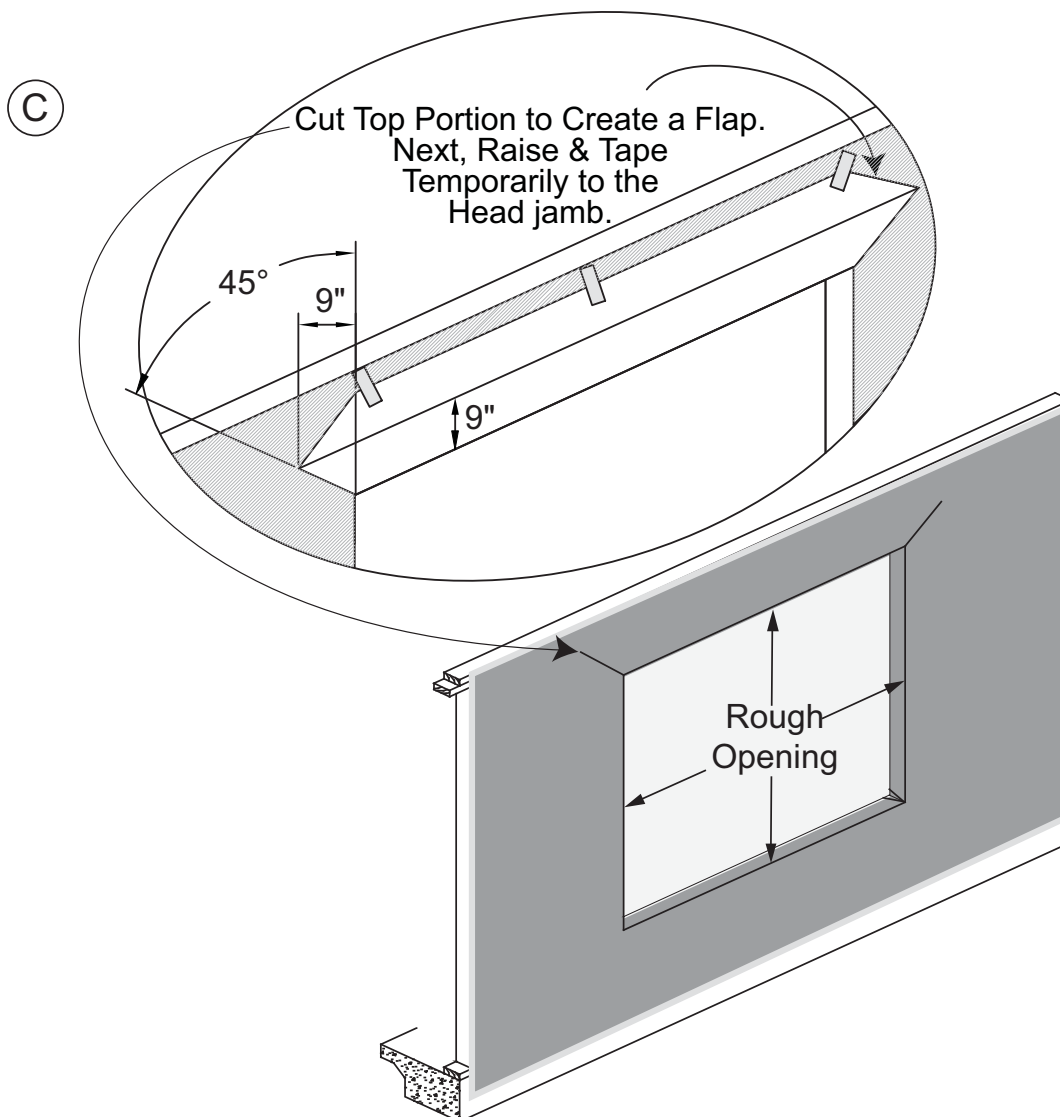

6

All Window Installation Instruction

Hurd
Windows and Doors

Hurd Window Installation Instructions - Apply Sill Flashing

1. Cut sill flashing to length. Length = Rough Opening width + 2 x Flashing Tape Width
2. Apply the horizontal sill flashing level with the top edge of the rough opening frame as shown below in **(D)**. Each end of the sill flashing is to extend 9" beyond the rough opening on each side of the jambs.
3. Fasten the top edge of the sill flashing to the framing with staples.
 - Locate the staples 12" - 16" apart along the edge where they will be covered by the nail fin mounting flange.
4. When the building exterior finishing is not applied immediately, apply tape at the corners and edges of the flashing to prevent wind damage. To avoid trapping water behind the flashing, never apply the tape continuously.

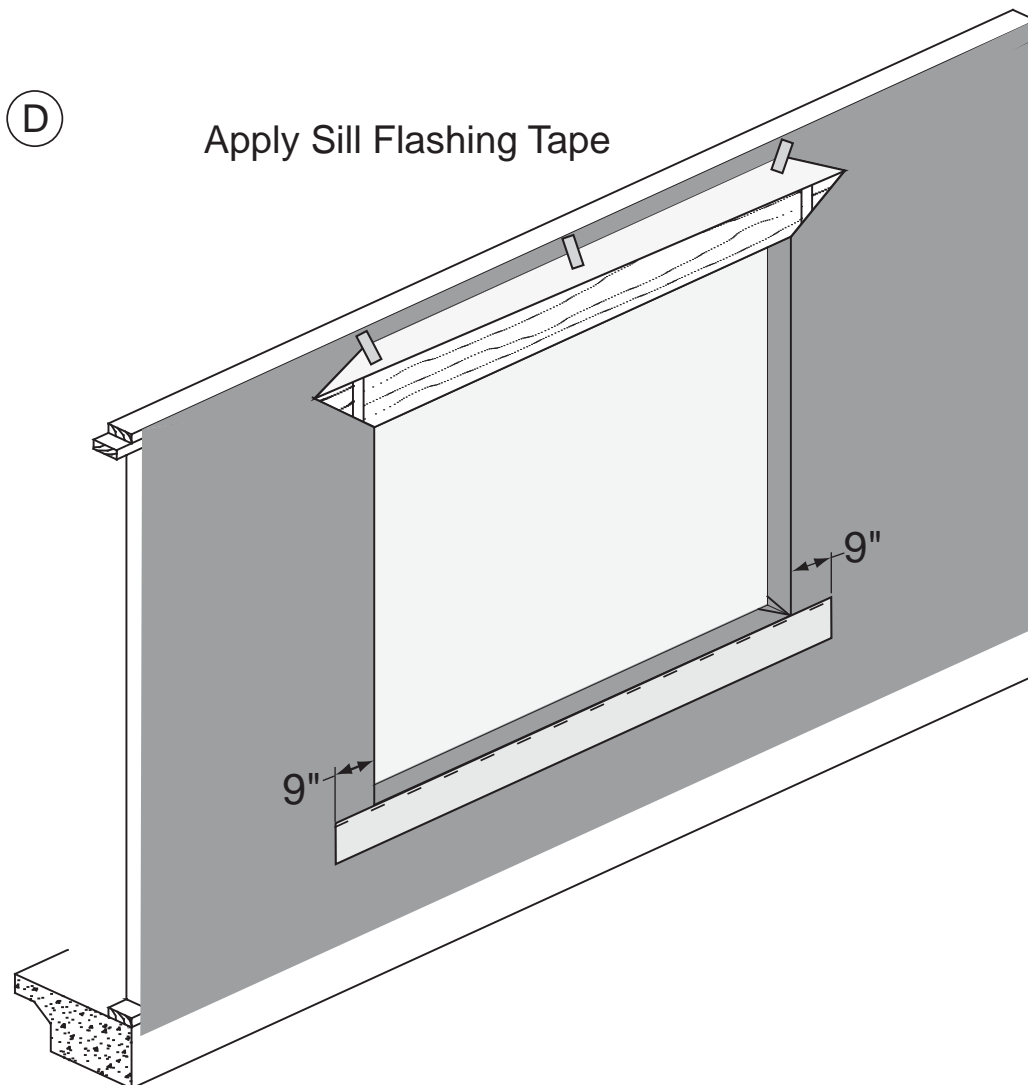

Illustration re-printed by permission
from InstallationMasters™ Institute.

7

Nail Fin Installation Instruction

Hurd
Windows and Doors

Hurd Window Installation Instructions with Nail Fin - Install Window

1. Use a sealant compatible with the nailing fin and exterior face of the structure.
2. Apply a 3/16" bead of sealant to the back side (interior surface) of the mounting flange of the window as shown in (E).
3. Apply the sealant in line with the pre-punched holes or slots on the mounting flange.
 - Alternatively, sealant may be applied to the framed opening at the point where the back side of the mounting flange, or approximately 1/4" away from the rough opening, will make contact with the perimeter seal.
4. Immediately set the window in to the opening, pressing it tight to the building.

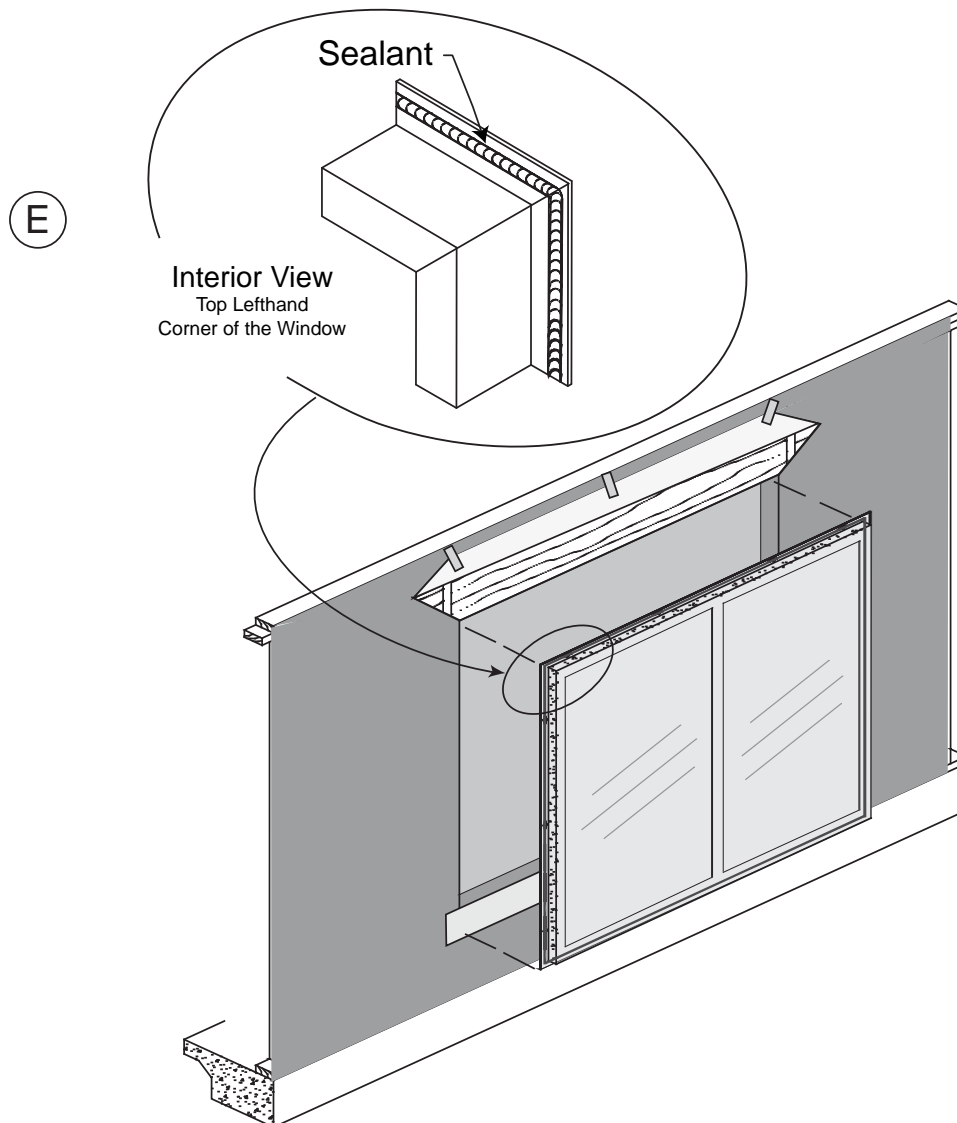
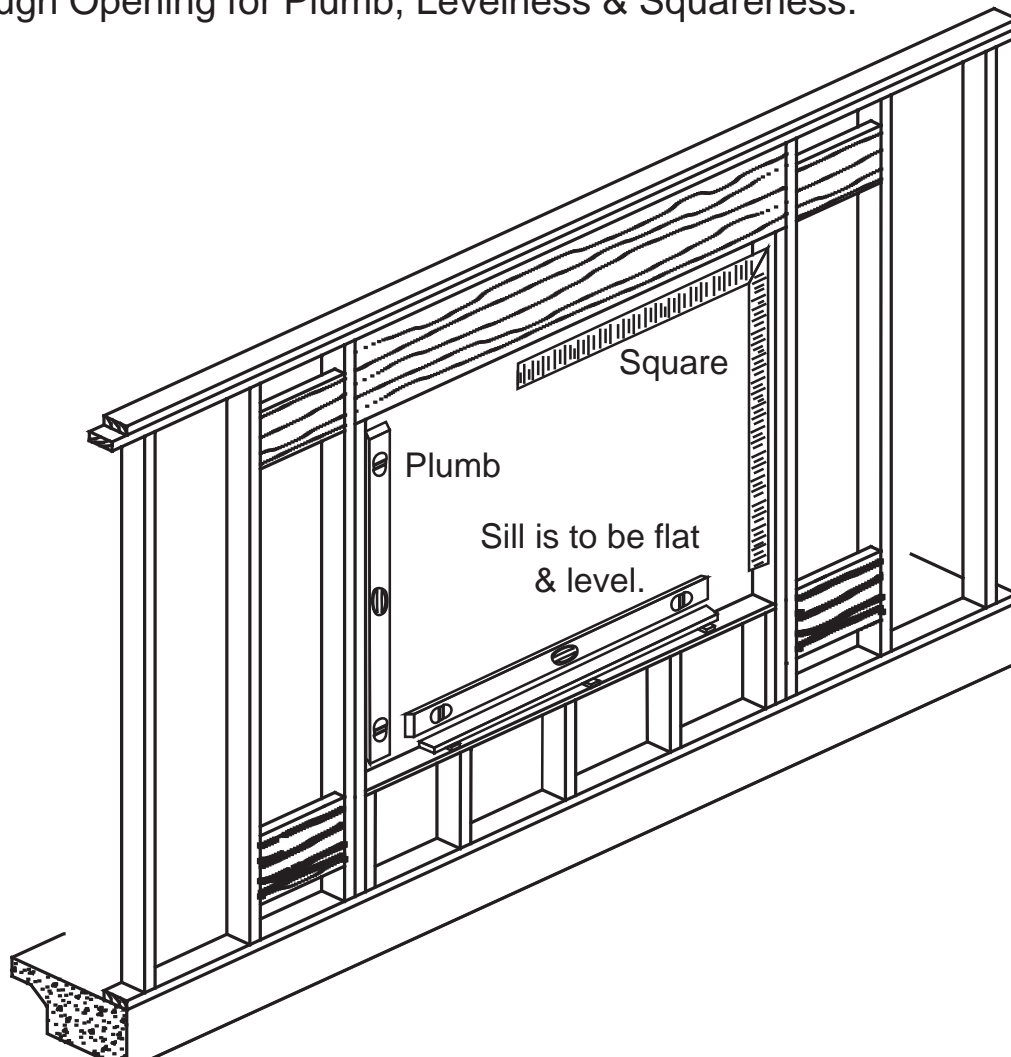

Illustration re-printed by permission
from InstallationMasters™ Institute.

Hurd Window Installation Instructions - Check Plumb, Levelness & Squareness

5. Select and apply shims at the sill and sides, to ensure that the unit is made level and plumb. If a mullered unit is installed shims must be applied at mull joint to help prevent sagging, deflection, distortion and rotation of the frame.
6. Starting at one corner, fasten the upper corner (on the side not on the top) in place through the mounting flange. Do not drive the fastener in all the way.
7. Adjust the shims and check the window as needed to ensure it is installed level, plumb and square as shown below.
8. Make sure the window is square, operates smoothly, and operable sash are sitting square in their openings.
9. Tack the corner diagonally opposite the upper corner that was tacked first.
10. Continue to fasten sides, top and bottom, rechecking the unit to ensure it is set plumb, level & square.
11. Fastener heads should not over compress the nail fin flange.

Check Rough Opening for Plumb, Levelness & Squareness.



Hurd Window Installation Instructions with Nail Fin - Apply Sealant

Jamb flashing is to be installed on the left and right sides of the rough opening. Use the steps that follow to apply jamb flashing:

1. The jamb flashing is to extend 8-1/2" beyond the head & sill of the rough opening as shown in **(H)**.
2. Apply a continuous bead of sealant to the exposed mounting nail fin flange (exterior surface) at the side jambs of the installed window as shown in **(H)**.
 - Place the bead vertically over the pre-punched holes and/or over the fastener heads, being sure to seal any penetrations or voids
 - For windows with mechanically applied mounting flanges, apply sealant to the full length of the joints or seam where the flanges meet.

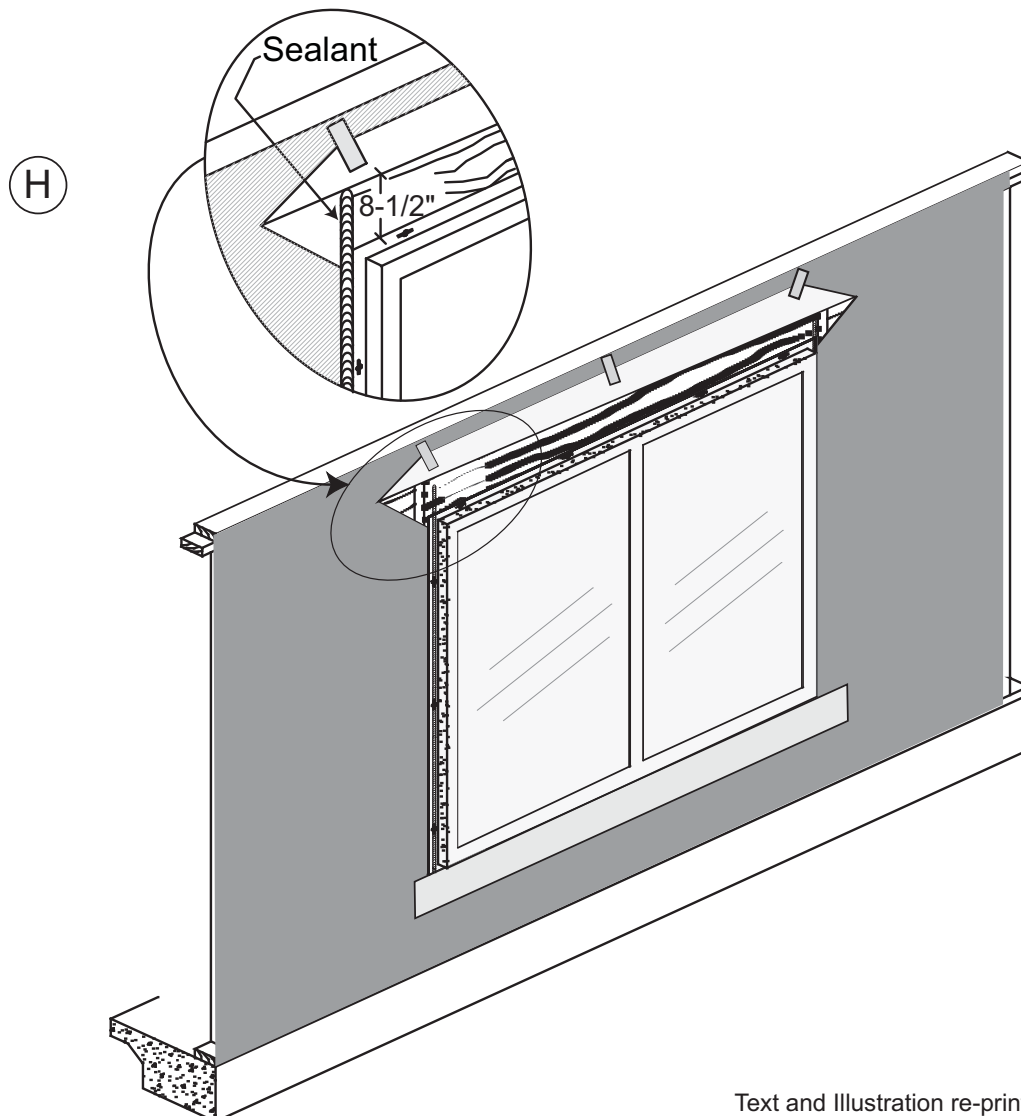

Hurd Window Installation Instructions with Nail Fin - Apply Sealant

3. Continue the sealant bead 8-1/2" above the rough opening at the head of the window to allow for application of the top portion (8-1/2") of the jamb flashing into sealant in the next step.
4. Install jamb flashing so the side edge covers the sealant bead. Press the flashing into the sealant.
 - Top edge of jamb flashing is to extend 8-1/2" maximum above the opening and is imbedded in sealant.
 - The bottom of the jamb flashing lies over the top of the sill flashing.
5. Use staples to attach the jamb flashing to the rough framing. Do not penetrate the window flange as shown in **(I)**.
6. When the building exterior will not be applied immediately, apply tape at the corners and edges of the flashing to prevent wind damage.
 - Note: To avoid trapping water behind the building wrap or weather barrier tape/flashing, never apply the tape continuously.
7. Repeat the above steps for the remaining strip of jamb flashing.

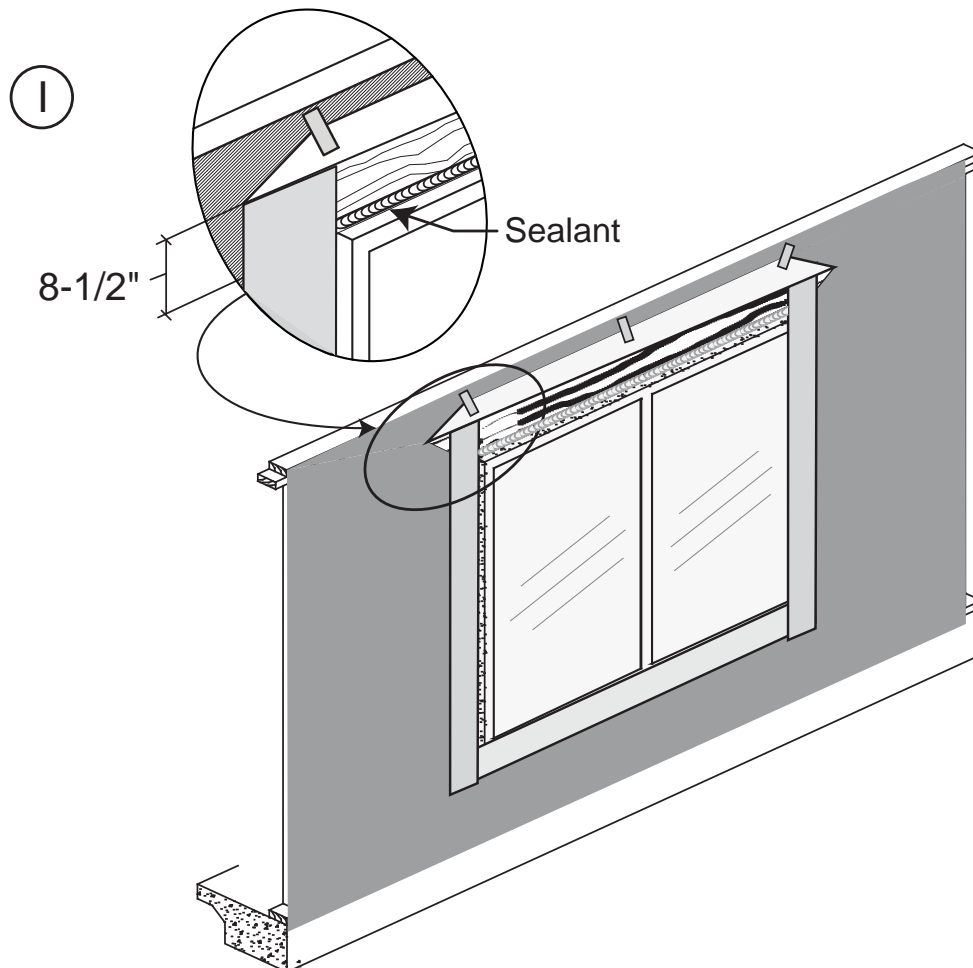

Hurd Window Installation Instructions with Nail Fin - Apply Head Flashing

1. Apply a bead of sealant at the head (over the nail fin mounting flange) of the installed window, directly over the fasteners and the pre-punched holes. Do not extend the bead of sealant beyond the jamb mounting flange.
2. Tuck the head flashing under the flap of the building wrap at the head.
 - Press the head flashing into the sealant beads previously applied until the sealant appears along the bottom edge as shown in (J). This will help remove any voids or air pockets behind the flashing.
3. Remove the previously applied tape which holds the flap of the building wrap at the head.
4. Allow the flap to lie flat over the head flashing.
5. Apply a new piece of sheathing tape over the entire diagonal cut made in the building wrap.
6. Use a roller to compress the tape against the building wrap and the head flashing which extends over the jamb.

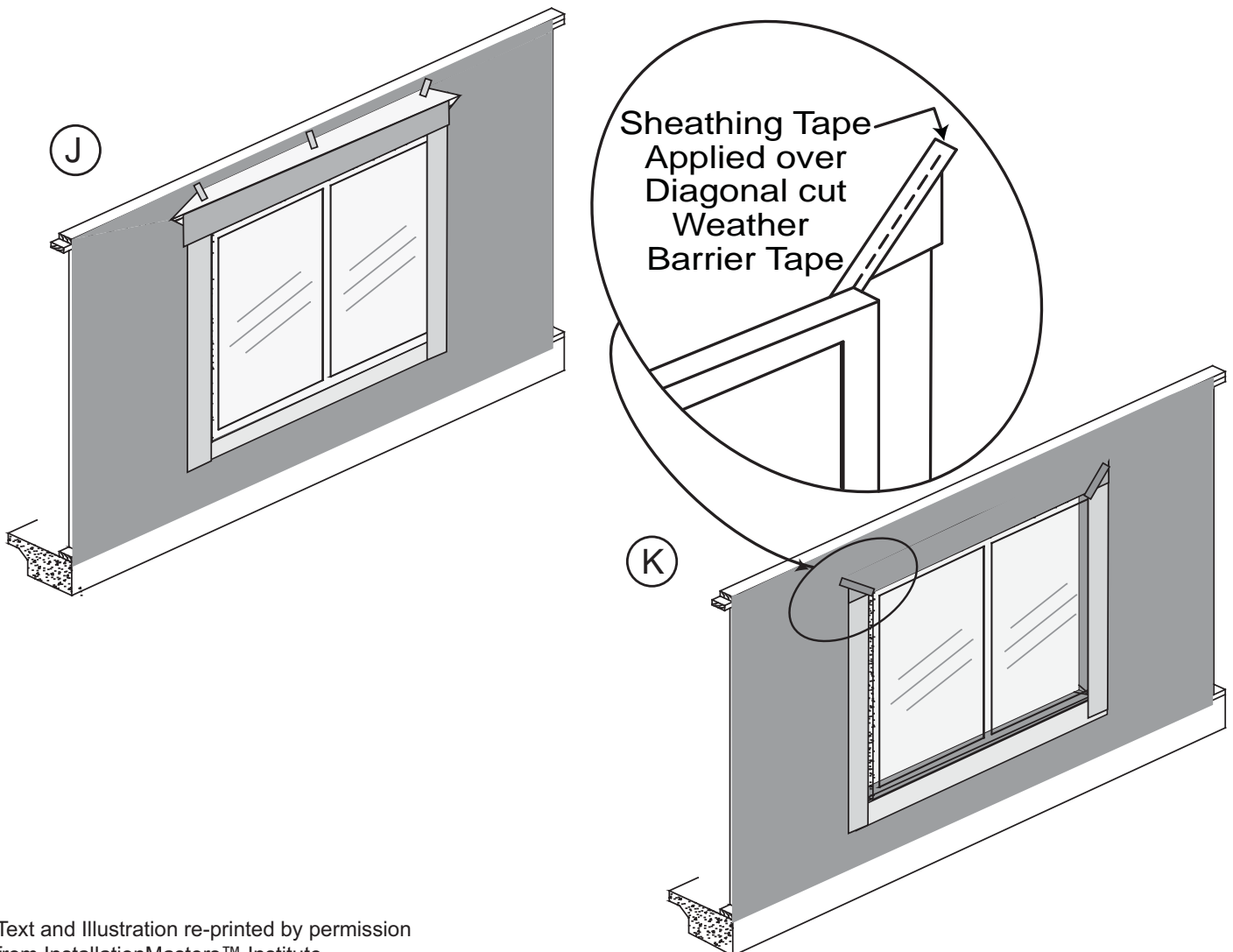

Installation Instruction



Hurd Window Installation Instructions Special Shaped Units - Flashing Application

Follow the instructions shown on pages 3 through 8 to prep the opening and window for installation. Flashing for a half-circle unit is shown below, full circles and other shapes are similar, in that you apply the flashing in the same sequence as shown in the illustration below.

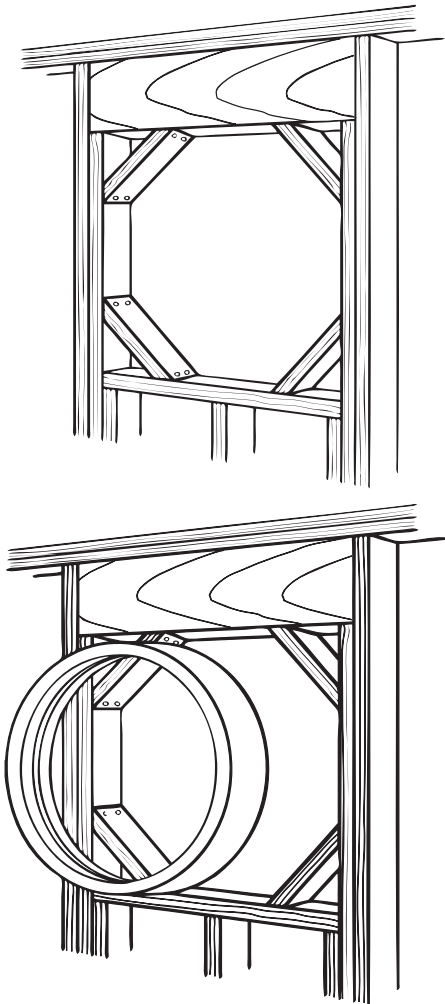

NOTE: PLACE EACH PIECE OF FLASHING IN ORDER AS SHOWN IN A WATER SHEDDING FASHION. START AT THE BOTTOM AND WORK TOWARD THE TOP OVERLAPPING THE FLASHING BELOW

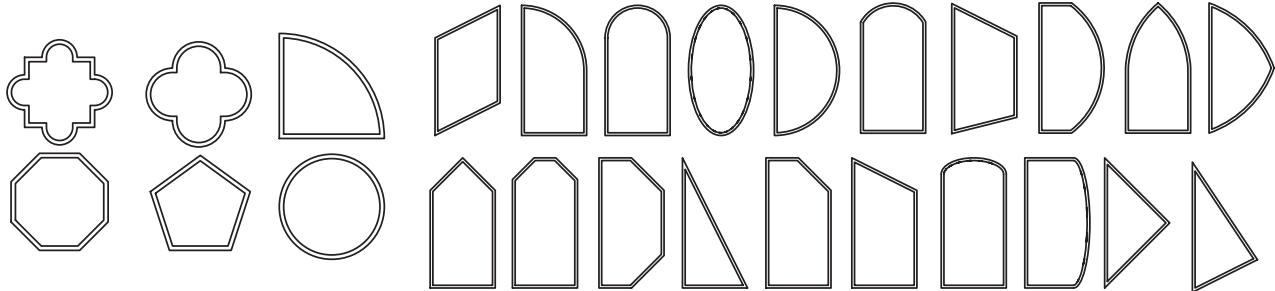
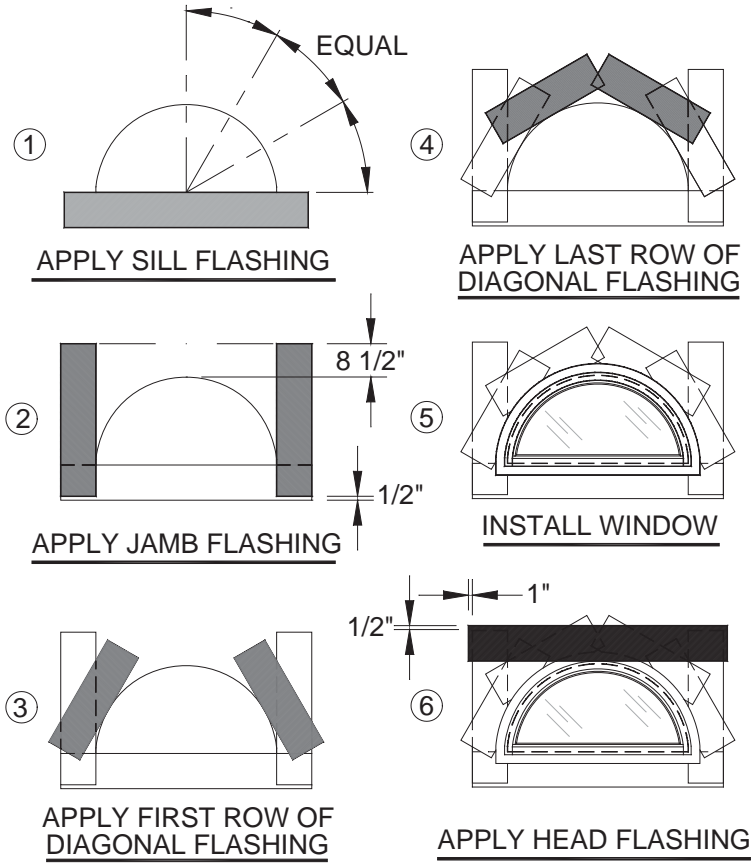

Wood Brick Mould Window Unit Installation Instruction



Hurd Window Installation Instructions with Brick Mould - Flashing and Sill Pan Install

For the installation of Wood Brick Mould units, follow instructions on pages 2-6 first. Then apply the side and head flashing as shown below. Sill pan flashing must be present. Follow the instructions and illustration on pages 14BM-16BM, for sealant and shimming placement. After installing the window follow instructions on Page 8 for level, square and plumb.

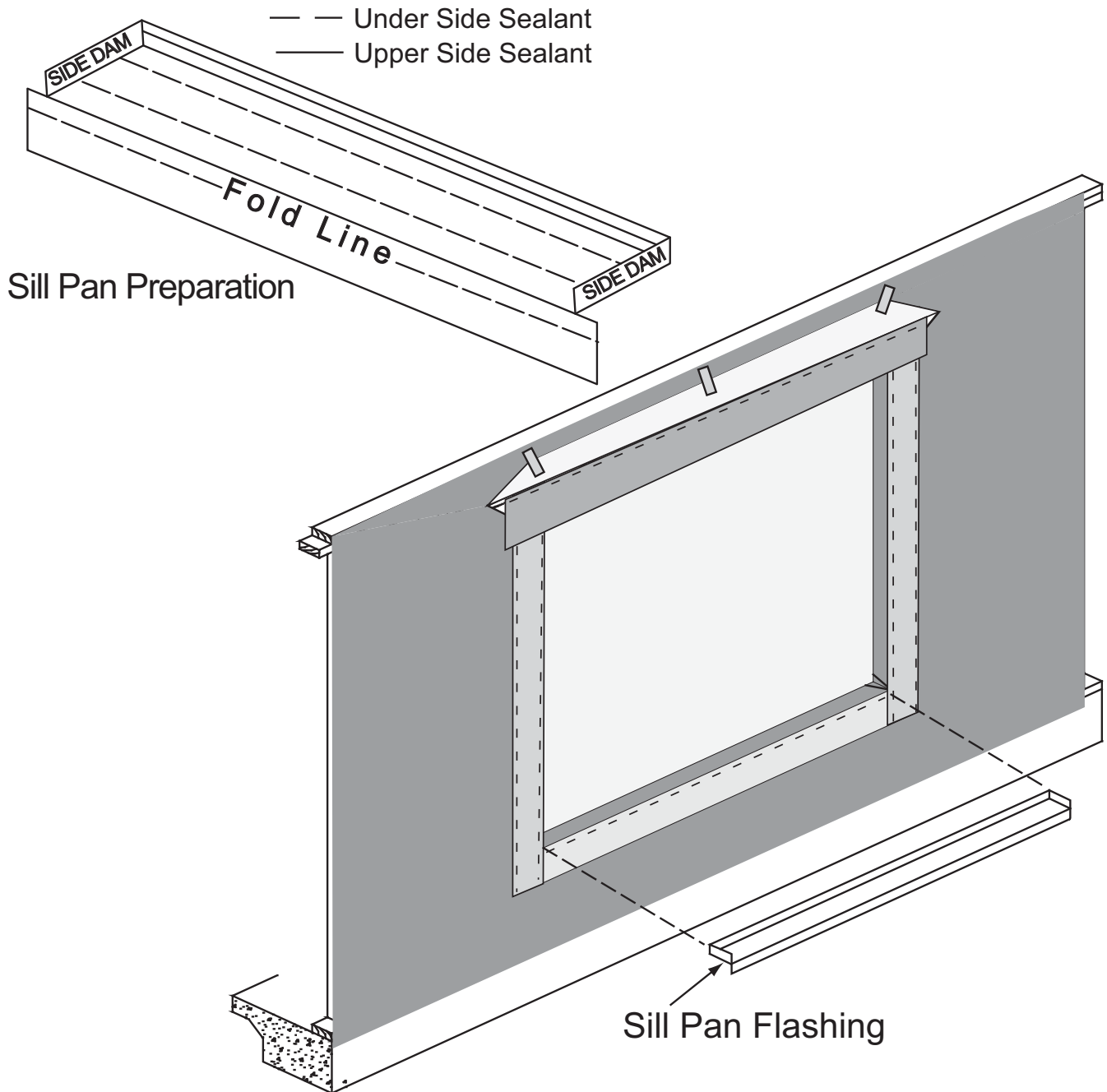

Wood Brick Mould Window Unit Installation Instruction



Hurd Window Installation Instructions with Brick Mould - Sill Condition

When placing the unit in the opening, place shims between the unit and the sill pan as shown in (4).

Run a continuous bead of sealant between the sill horn and the sill pan and another bead of sealant between the sill pan and the window frame as shown in (5).

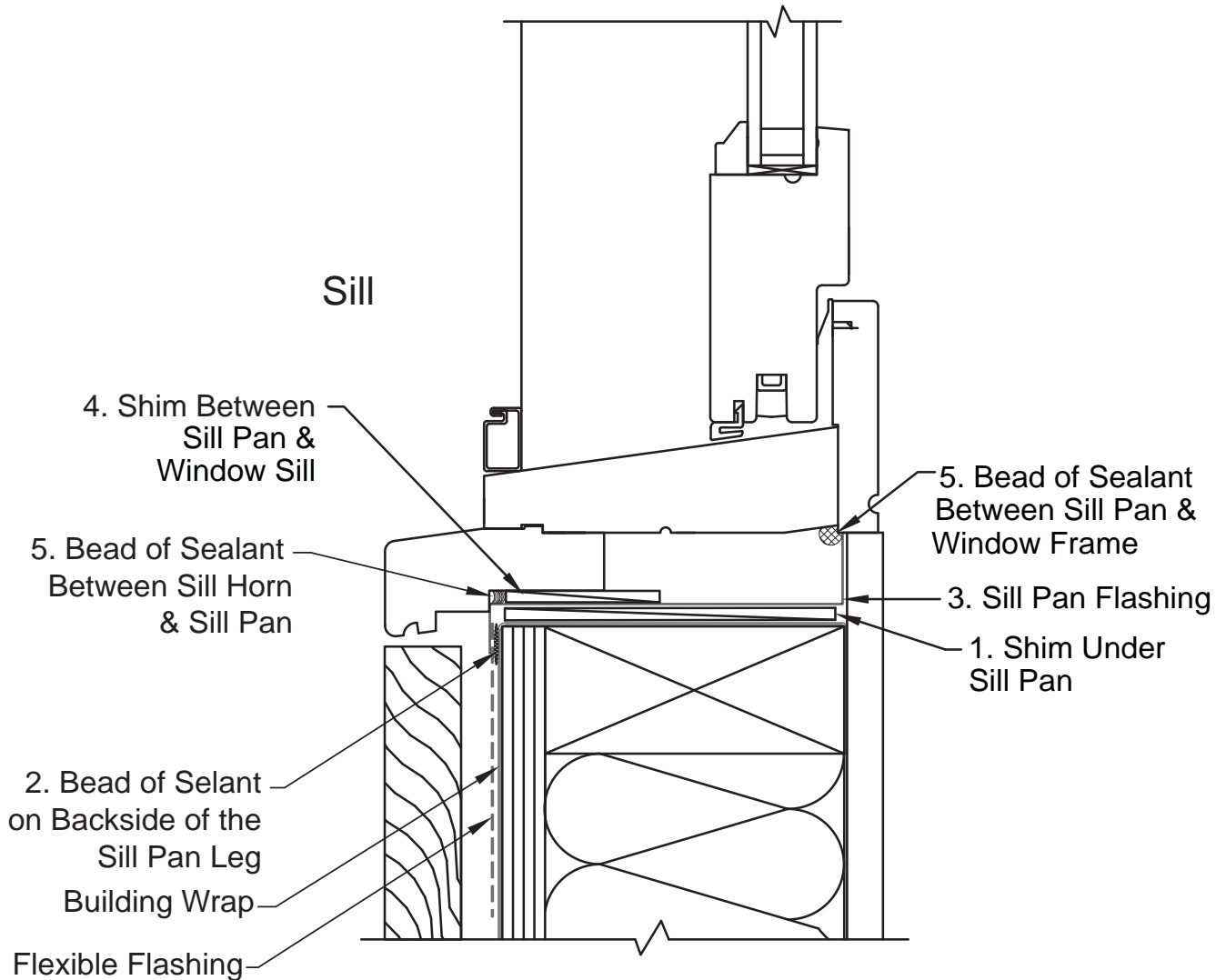

15
BM

Wood Brick Mould Window Unit Installation Instruction

Hurd
Windows and Doors

Hurd Window Installation Instructions with Brick Mould - Jamb Condition

Side jamb detail shown below.

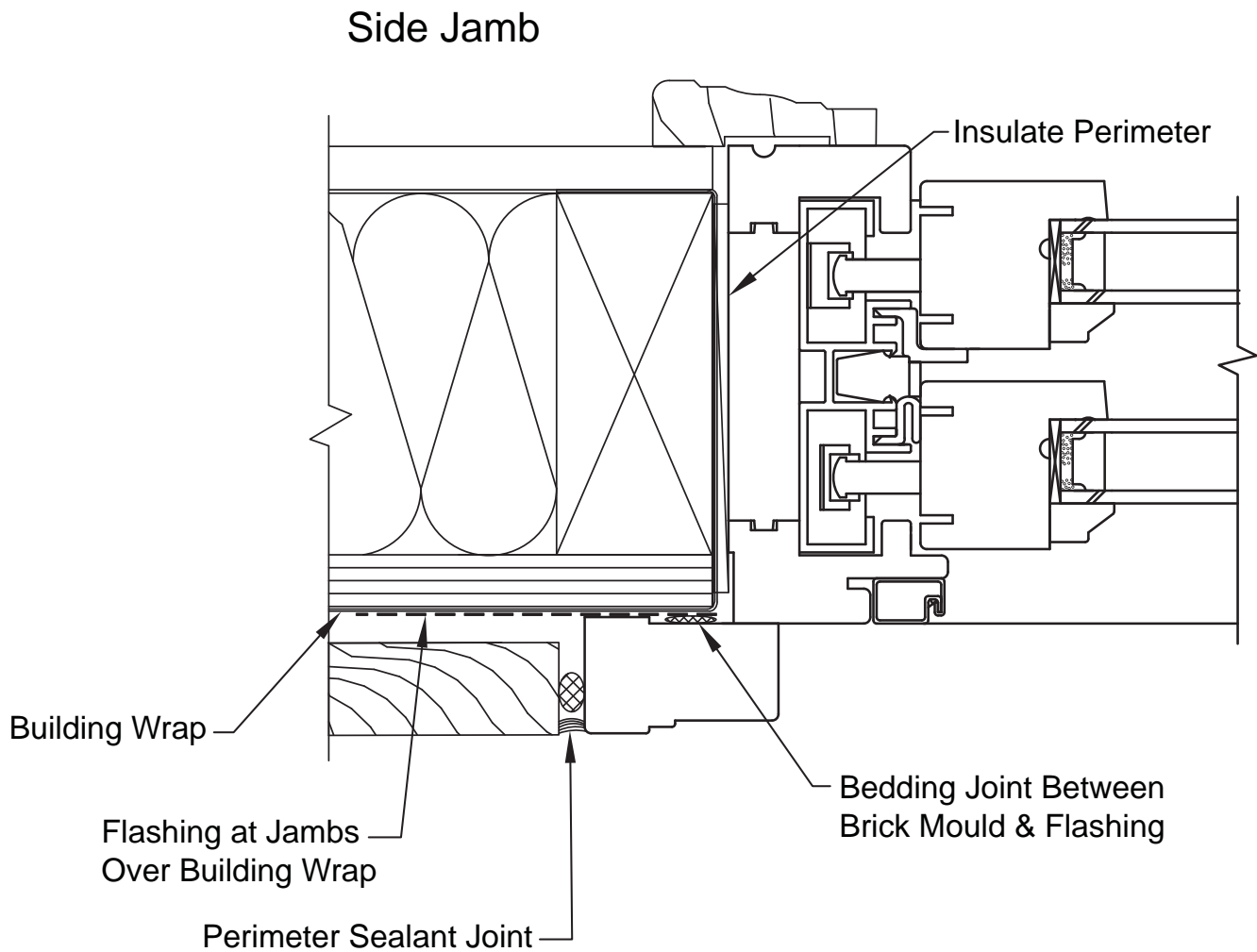

Wood Brick Mould Window Unit Installation Instruction



Hurd Window Installation Instructions with Brick Mould - Head Condition

Head detail shown below.

