

INSTALLATION INSTRUCTIONS

NATURAL TO PROPANE CONVERSION KIT

NAHA00801LP or PART NO. 1183388

NOTE: Read the entire instruction manual before starting the installation.

SAFETY CONSIDERATIONS

Installing and servicing heating equipment can be hazardous due to gas and electrical components. Only trained and qualified personnel should install, repair, or service heating equipment.

Untrained personnel can perform basic maintenance functions, such as cleaning and replacing air filters. Trained service personnel must perform all other operations. When working on heating equipment, observe precautions in the literature, on tags, and on labels attached to or shipped with the unit, and other safety precautions that may apply.

Follow all safety codes. In the United States, follow all safety codes including the National Fuel Gas Code (NFGC) NFPA 54-2009/ANSI Z223.1-2009.

Wear safety glasses and work gloves. Have a fire extinguisher available during start-up, adjustment Steps, and service calls.

Recognize safety information. This is the safety-alert symbol . When you see this symbol on the furnace and in instructions or manuals, be alert to the potential for personal injury.

Understand the signal words DANGER, WARNING, and CAUTION. These words are used with the safety-alert symbol. DANGER identifies the most serious hazards which **will** result in severe personal injury or death. WARNING signifies a hazard which **could** result in personal injury or death. CAUTION is used to identify unsafe practices which **may** result in minor personal injury or product and property damage. NOTE is used to highlight suggestions which **will** result in enhanced installation, reliability, or operation.

TABLE OF CONTENTS

Safety Considerations	1
Introduction	1
Description and Usage	1
Installation Induced-Combustion, Single-stage, Non-Condensing	2
ECM Single Stage Control	5
Installation Induced-Combustion, Two-Stage, and Variable Speed	8
Furnace Control for Two-Stage Non-Condensing Furnaces	12
Furnace Control for Variable Speed Non-Condensing Furnaces	12

ISO 9001:2000



WARNING

FIRE, EXPLOSION, ELECTRICAL SHOCK, AND CARBON MONOXIDE POISONING HAZARD

Failure to follow this warning could result in personal injury or death.

This conversion kit shall be installed by a qualified service agency in accordance with the manufacturer's instructions and all applicable codes and requirements of the authority having jurisdiction. If the information in these instructions is not followed exactly, a fire, explosion, or production of carbon monoxide could result causing property damage, personal injury, or loss of life. The qualified service agency is responsible for the proper installation of this furnace with this kit. The installation is not proper and complete until the operation of the converted appliance is checked as specified in the manufacturer's instructions supplied with the kit.

INTRODUCTION

These instructions cover the installation of gas conversion kit to convert the following furnaces from natural gas usage to propane gas usage. See appropriate section for your furnace type.

NOTE: For use on 33.3 inch (846mm), multipoise, non-condensing furnace to convert from natural gas to propane gas.

Section 1 Models: N8MSN, N8MSL, F8MXN, G8MXN, F8MXL and G8MXL 33.3-Inch High, Induced-Combustion, Hot-Surface Ignition, Single Stage, Non-Condensing 4-Way Multipoise Furnaces with 42,000 through 154,000 Btuh gas input rates.

Section 2 Models: F8MVL, G8MVL, F8MTL and G8MTL, 33.3-Inch High, Induced-Combustion, Hot-Surface Ignition, Two-Stage and Variable-Speed, Non-Condensing Furnaces. This kit is designed for use in furnaces with 42,000 through 132,000 Btuh gas input rates.

WARNING

FIRE, EXPLOSION, ELECTRICAL SHOCK HAZARD

Failure to follow this warning could result in personal injury, death or property damage.

Gas supply **MUST** be shut off before disconnecting electrical power and proceeding with conversion.

DESCRIPTION AND USAGE

This kit is designed for use in the furnaces listed above. See Table 1 for kit contents. To accommodate many different furnace models, more parts are shipped in kit than will be needed to complete conversion. When installation is complete, discard extra parts.

Table 1 – Kit Contents

DESCRIPTION	QTY
Main Burner Orifice (Drill Size 1.30 mm)	7
Main Burner Orifice (Drill Size 1.25 mm)	7
Main Burner Orifice (Drill Size No. 55)	7
Main Burner Orifice (Drill Size No. 56)	7
Screw, Spoiler Size No. 4	7
Low Gas Pressure Switch (Propane) (LGPS)	1
Nipple Size 1/8 MPT	1
90° Street Elbow (1/8 in. / 3 mm)	1
Male X Female X Female Tee (1/8 in. / 3 mm)	1
Splice Connector (1/4 in. Male, Both Ends)	1
Splice Connector (3/16 in. Male, Both Ends)	1
Orange Wire Assembly (18 in. / 457 mm)	2
Orange Wire Assembly (12 in. / 305 mm)	1
Yellow Wire Assembly (6 in. / 152 mm)	1
Yellow Wire Assembly (14 in. / 356 mm)	1
Yellow Wire Assembly (16 in. / 406 mm)	1
Wire Tie	1
337057–201 Conversion Rating Plate Label—Non—Condensing Furnaces	1
337057–204 Conversion Rating Plate Label—Non—Condensing Furnaces	1
337057–205 Conversion Responsibility Label	1
337057–202 Gas Control Conversion Label (adjusted)	1
337057–203 Gas Control Conversion Label (converted)	1
Installation Instructions	1
Regulator Spring Kit (White—Propane—EF39ZW023) for White—Rodgers 36C,36E, 36F, 36G and 36J Valve	2
Drill Bit Size 5/64"	1

**INSTALLATION
SECTION 1
INDUCED-COMBUSTION,
HOT-SURFACE IGNITION,
SINGLE-STAGE, 33.3-INCH (846 MM)
HIGH, NON-CONDENSING FURNACES**

SINGLE STAGE FURNACES		
N8MSN	F8MXN	G8MXN
N8MSL	F8MXL	G8MXL

Step 1 — Install Main Burner Orifices and Burner Spoiler Screws

⚠ CAUTION

UNIT DAMAGE HAZARD

Failure to follow this caution may result in unit damage.

DO NOT re-drill burner orifices. Improper drilling may result in burrs, out-of-round holes, etc. Obtain new orifices if orifice size must be changed. (See Figure 1)

NOTE: See Figure 2 for component location in UPFLOW orientation. Reorient component arrangement when furnace is installed in other positions.

Figure 1 – Burner Orifice

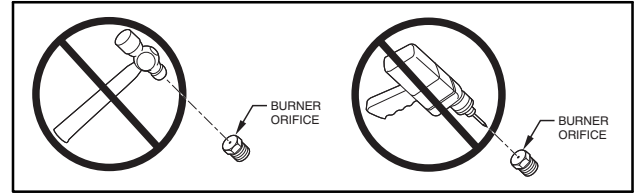

A96249

1. Turn off furnace gas and electrical supplies.
2. Remove outer door.
3. Turn furnace gas valve switch to OFF position.
4. If furnace is oriented in a manner that the vent connector interferes with burner removal, remove vent connector from vent elbow inside the furnace. Support the remaining vent connector with temporary metal wire or straps to prevent damage to the remaining portions of the vent connector.
5. Remove gas supply pipe from gas valve (if installed).
6. Disconnect wires from gas valve
7. Remove the two (2) screws on the left side that secure the manifold to the burner box.
8. Swing out manifold from burners then pull manifold out of right side of burner box. (See Figure 2)
9. Remove and discard orifices from manifold.
10. Refer to conversion kit rating plate 337057–204 to determine main burner orifice size. (See Figure 13)

⚠ CAUTION

UNIT OPERATION HAZARD

Failure to follow this caution may result in unit damage or improper operation.

Label all wires prior to disconnection when servicing controls.

Gas input rate on furnace rating plate is for installations at altitudes up to 2000 ft. (609 M).

In the U.S.A.: the input rating for altitudes above 2000 ft. (609 M) must be reduced by 4 percent for each 1000 ft. (305 M) above sea level.

The Conversion Kit Rating Plate accounts for high altitude derate.

11. Install main burner orifices. Do not use Teflon tape. Finger-tighten orifices at least one full turn to prevent cross-threading, then tighten with wrench. There are enough orifices in each kit for largest furnace. Discard extra orifices.
12. To install burner spoiler screws, follow these steps:
 - a. Disconnect Hot Surface Igniter (HSI) wires from HSI.
 - b. Disconnect Flame Sensor wire from Flame Sensor.
 - c. Slide one-piece burner assembly out of slots on sides of burner box.
 - d. Remove the Hot Surface Igniter (HSI) and bracket from the burner assembly.
 - e. Remove the flame sensor from the burner assembly.
 - f. Locate the dimple on each burner venturi tube (Figure 3).

- g. Drill a 5/64-in. (2 mm) hole (supplied in kit) in each dimple.
- h. Install a spoiler screw in each drilled hole drilling as straight as possible

Figure 2 – Component Location

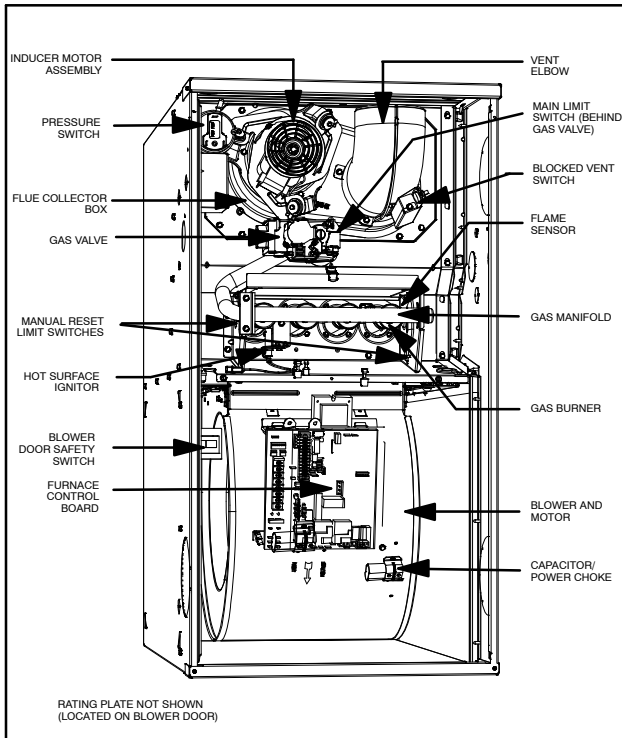
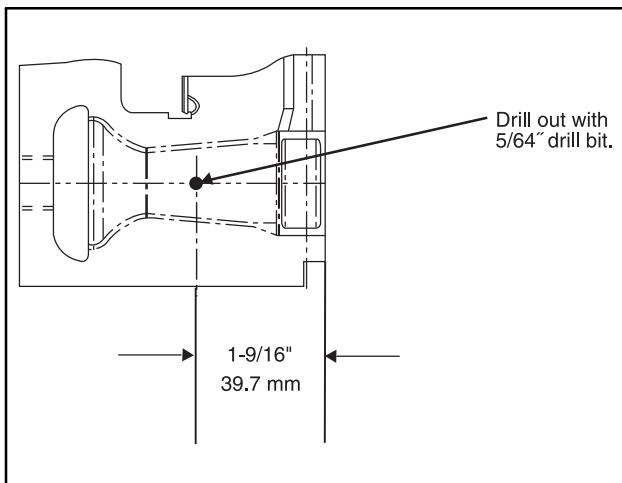

Figure 3 – Location of Dimple for Spoiler Screw



A06432

NOTE: Models N8MSL, F8MXL, and G8MXL are supplied with NOx emissions-reduction devices necessary for use with Natural Gas in NOx emissions-regulated areas.

CAUTION

UNIT DAMAGE HAZARD

Failure to follow this caution may result in unit damage.

Furnace models N8MSL, F8MXL, and G8MXL **MUST** have low NOx devices removed prior to operating furnace on propane gas.

- 13. For NOx device removal, follow these additional steps:

- a. Remove the screw underneath the heat exchanger inlet that secures the NOx device in the heat exchanger. (See Figure 4)
- b. Use a pair of needle nose pliers to remove the NOx device. Squeeze the sides of the device, if necessary, to remove from the heat exchanger.

Figure 4 – NOx Device Location

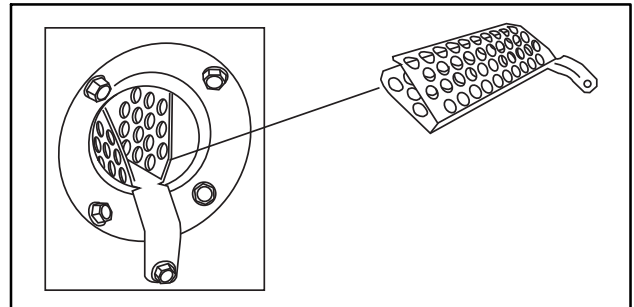

A02195

Figure 5 – Igniter to Burner

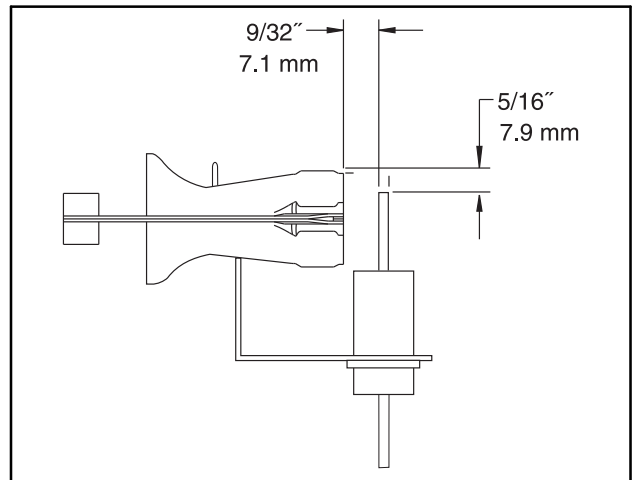

A05025

- c. Re-install screw in hole underneath heat exchanger inlet.

NOTE: It is very IMPORTANT to reinstall the NOx bracket mounting screw.

- d. Repeat steps a thru c for each heat exchanger.

- 14. To reinstall burner assembly:

- a. Attach flame sensor to burner assembly.
- b. Install HSI and bracket to burner assembly.
- c. Insert one-piece burner in slot on sides of burner box and slide burner back in place.
- d. Reattach HSI wires to HSI. Verify igniter to burner alignment. For Silicon Nitride igniters, see Figure 5 and Figure 6.
- e. Re-attach Flame sensor wire to Flame Sensor.

- 15. Reinstall manifold by inserting right end of manifold into opening in right side of burner box.

- 16. Swing manifold into burner assembly and insert orifices into openings on burners.

- 17. Verify that orifices are fully inserted into burners and burners are fully seated in burner box.

Figure 6 – Igniter to Burner

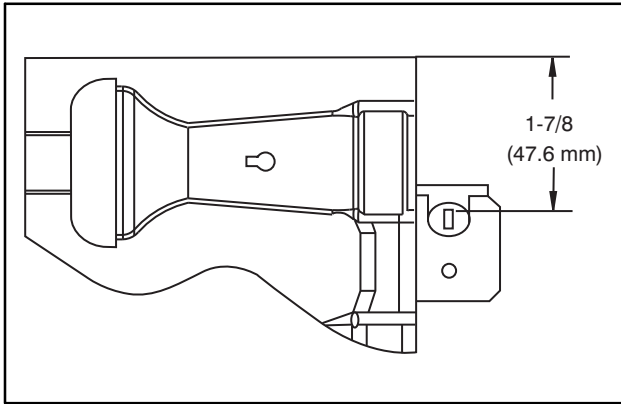

A05026

Figure 7 – Igniter to Burner

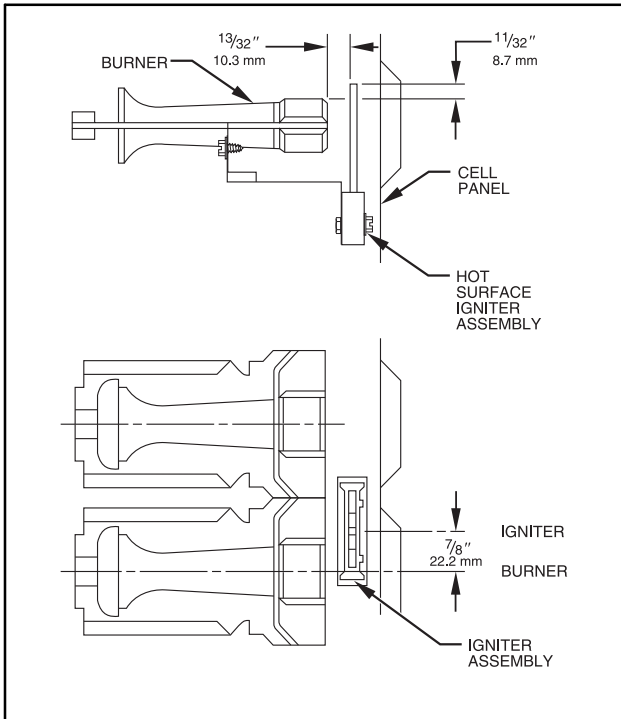

A93347

18. Secure manifold to left side of burner box, verifying that green ground wire is reattached to burner box.
19. Reconnect wires to gas valve per the wiring diagram supplied with the unit.

NOTE: Failure to attach ground wire to gas manifold on burner box will result in loss of flame signal resulting in a no heat condition.

NOTE: Use propane-gas resistant pipe dope to prevent gas leaks. DO NOT use Teflon tape.

Step 2 — Convert Single-Stage Gas Valve

NOTE: The following furnaces must have the regulator spring replaced in the gas valve:

SINGLE STAGE FURNACES		
N8MSN	F8MXN	G8MXN
N8MSL	F8MXL	G8MXL

1. Be sure main gas and electrical supplies are off.
2. Remove regulator seal cap. (Figure 10)
3. Remove adjustment screw and natural gas regulator spring (silver).

4. Install propane gas regulator spring (white) in gas valve.
5. Turn regulator adjustment screw clockwise (in) 8.5 turns for Figure 8. Go to Step 3

NOTE: DO NOT reinstall regulator seal cap at this time.

Figure 8 – Single Stage Gas Valve Series G / J

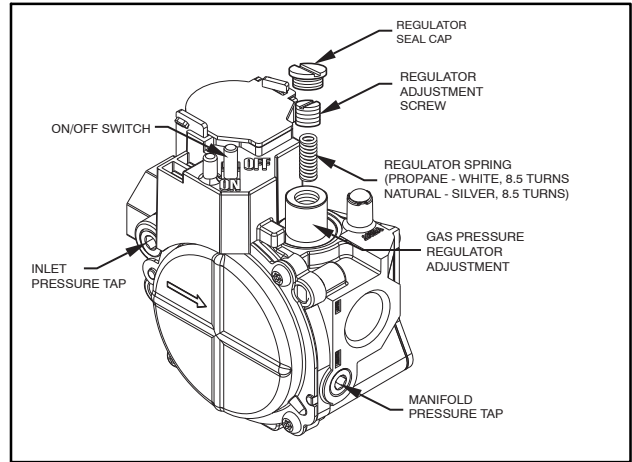

A07017

Figure 9 – Gas Valve Inlet Pressure Tap

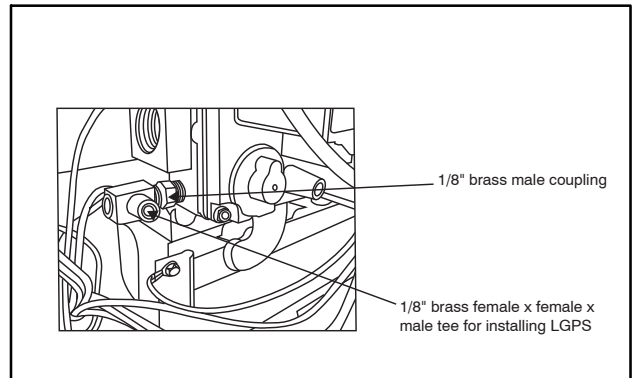

A05155

Figure 10 – LGPS Installed

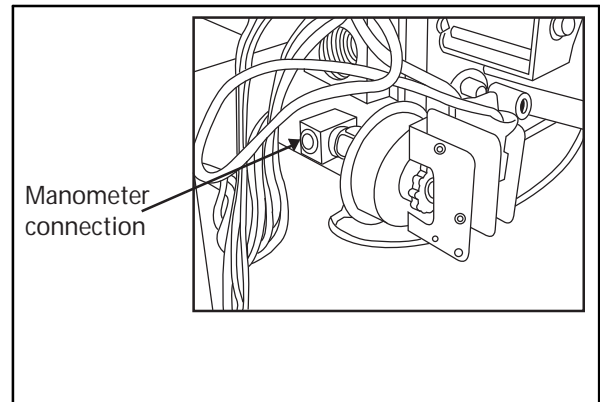

A05191

Step 3 — Install Low Gas Pressure Switch (LGPS)

NOTE: The inlet gas pipe must be disconnected from valve so pressure switch can be installed.

NOTE: Use propane-gas-resistant pipe dope on all connections to prevent gas leaks. DO NOT use Teflon tape.

1. Be sure main gas and electric supplies to furnace are off.

2. Remove 1/8-in. (3 mm) pipe plug from inlet pressure tap on gas valve. (See Figure 8) DO NOT DISCARD 1/8-in. (3 mm) PLUG.
3. Apply pipe dope sparingly to one end of 1/8-in. (3 mm) brass male coupling (provided in kit) and install the doped end in 1/8-in. (3 mm) tapped opening in gas valve inlet pressure-tap. Tighten fitting with a small open-end wrench. (See Figure 9)
4. Apply pipe dope sparingly to opposite end of the 1/8-in. (3 mm) brass coupling (provided in kit). Install the female end of the female x female x male tee on the brass coupling. Tighten coupling finger tight. Use a small open-end wrench for final tightening. (See Figure 9)
5. Apply pipe dope sparingly to male end of brass tee. Install propane low gas pressure switch (provided in kit) on male end of the female x female x male tee. Tighten switch finger tight. Use a small open-end wrench on base of pressure switch for final tightening. (See Figure 10)
6. Connect a manometer to the open end of the tee installed in the gas valve. (See Figure 9 and Figure 10)
7. Apply pipe dope sparingly to end of inlet gas pipe and reconnect pipe to gas valve.

Step 4 — Check Inlet Gas Pressure

NOTE: This kit is to be used only when inlet gas pressure is between 11.5-in. w.c. and 13.6-in. w.c.

1. Verify manometer is connected to the brass tee connected to the inlet pressure tap on gas valve. (See Figure 9 or Figure 10)

⚠ **CAUTION**

UNIT DAMAGE HAZARD

Failure to follow this caution may result in unit damage.

DO NOT operate furnace more than one minute to check inlet gas pressure, as conversion is not complete at this time.

2. Turn on furnace power supply.
3. Turn gas supply manual shutoff valve to ON position.
4. Turn furnace gas valve switch to ON position.
5. Jumper R-W thermostat connections on the Single Stage furnace control (see Figure 11).
6. When main burners ignite, confirm inlet gas pressure is between 11.5-in. w.c. and 13.6-in. w.c.
7. Remove jumper across thermostat connections to terminate call for heat.
8. Turn furnace gas valve switch to OFF position.
9. Turn gas supply manual shutoff valve to OFF position.
10. Turn off furnace power supply.
11. Remove manometer.
12. Apply pipe dope sparingly to end of inlet gas pipe plug and install into unused end of 1/8-in. (3 mm) tee. Use a small back-up wrench on tee when tightening gas inlet pipe plug. (See Figure 9 or Figure 10)

Figure 11 – ECM Single Stage Control

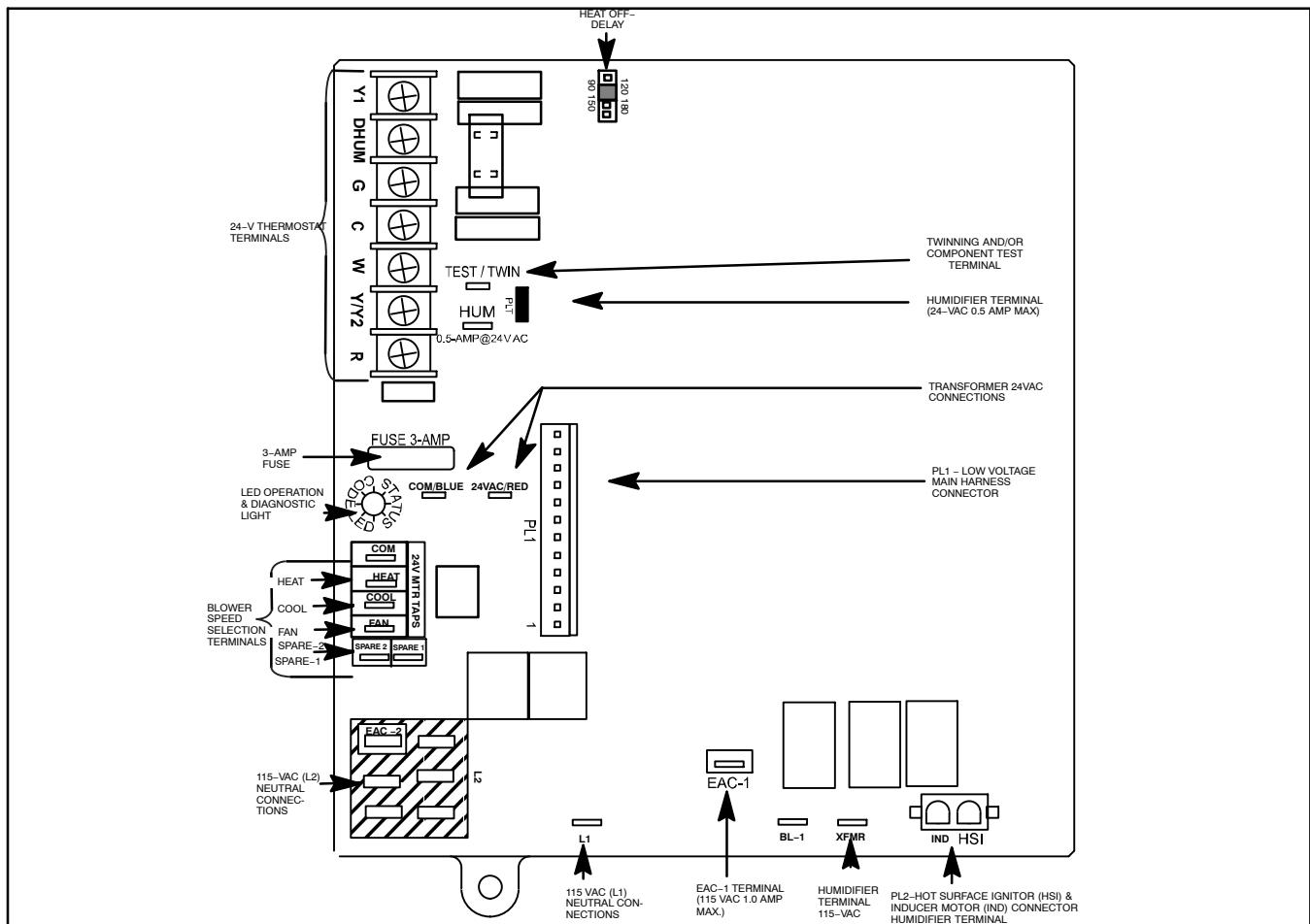

Step 5 — Modify Single Stage Pressure Switch Wiring

Refer to furnace wiring diagram (located inside unit).

1. Disconnect yellow wire from the N.O. contact of the pressure switch PRS and connect it to the N.O. terminal on the low gas pressure switch (LGPS).
2. Connect the insulated straight terminal of the 16-in (406 mm) yellow wire (provided in kit) to the C terminal on the low gas pressure switch (LGPS).
3. Connect insulated flag terminal of 16-in (406 mm) yellow wire to the N.O. terminal to pressure switch PRS.
4. Route yellow wires along wire harness. Secure with wire tie provided in kit. Go to Step 6.

Step 6 — Check Furnace Operation and Make Necessary Adjustments

1. Be sure main gas and electric supplies to furnace are off.
2. Remove 1/8-in. (3 mm) pipe plug from manifold pressure tap on downstream side of gas valve. (See Figure 8)
3. Attach manometer to manifold pressure tap on gas valve.

NOTE: The 1/8-in. (3 mm) NPT street elbow included in the kit may be attached to the gas valve manifold pressure tap or a field supplied 90° 1/8-in. (3 mm) NPT barbed fitting may be used to simplify manometer connection to gas valve when vent connector passes inside furnace casing. (See Figure 13) The street elbow may be left in place on gas valve when plug from manifold pressure tap is installed in street elbow.

4. Turn gas supply manual shutoff valve to ON position.
5. Turn furnace gas valve switch to ON position.
6. Check all threaded pipe connections for gas leaks.
7. Turn on furnace power supply.

Figure 12 – Plug Removed from Gas Valve Street Elbow Installed and Plug Reinstalled in Elbow

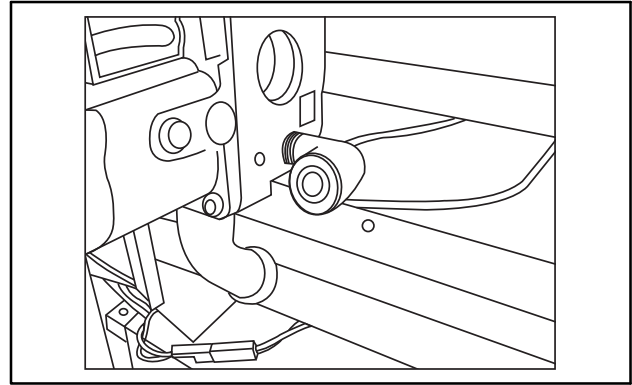

A02197

▲ WARNING

FIRE AND EXPLOSION HAZARD

Failure to follow this warning could result in personal injury and/or death.

NEVER test for gas leaks with an open flame. Use a commercially available soap solution made specifically for the detection of leaks to check all connections.

Step 7 — Gas Input Rate Information

The gas-input rate for propane is the same as for natural gas. See furnace rating plate for input rate. The input rate for propane is determined by manifold pressure and orifice size.

Gas input rate on furnace rating plate is for installations at altitudes up to 2000 ft. (609 M).

In the U.S.A.: the input rating for altitudes above 2000 ft. (609 M) must be reduced by 4 percent for each 1000 ft. (305 M) above sea level.

The Conversion Kit Rating Plate accounts for high altitude derate.

Figure 13 – Conversion Kit Rating Plate – 337057-201

CONVERSION KIT RATING PLATE - INTERNATIONAL COMFORT PRODUCTS, LLC											
THIS APPLIANCE HAS BEEN CONVERTED TO USE PROPANE GAS FOR FUEL. REFER TO KIT INSTRUCTIONS FOR CONVERSION PROCEDURES. USE PARTS SUPPLIED BY MANUFACTURER AND INSTALLED BY QUALIFIED PERSONNEL. SEE EXISTING RATING PLATE FOR APPLIANCE MODEL NO. AND INPUT RATING.											
NOTE: Furnace gas input rate on rating plate is for installations up to 2000 ft. above sea level. In U.S.A. the input rating for altitudes above 2000 ft. must be derated by 2% for each 1000 ft. above sea level. In Canada the input rating must be derated by 5% for altitudes of 2000 ft. to 4500 ft. above sea level.											
KIT NUMBER: NAHA00801LP			FUEL USED: PROPANE GAS INLET PRESSURE (min - max): 11.5 - 13.6 in. wc								
APPLIANCE MODELS		ALTITUDE OF INSTALLATION (FT. ABOVE SEA LEVEL) U.S.A. *									
		0 to 2000	2001 to 3000	3001 to 4000	4001 to 5000	5001 to 6000	6001 to 7000	7001 to 8000	8001 to 9000	9001 to 10000	
N8MSL, N8MSN, G8MXN, G8MXL, F8MXN, F8MXL	ORIFICE NO.	55	1.30mm	1.30mm	1.25mm	1.25mm	1.25mm	56	56	56	
	MNFLD PRESS	11.0	11.0	10.5	11.0	11.0	10.5	11.0	11.0	10.5	
* For Canadian Installations from 2000 to 4500 ft use U.S.A. column 2001 to 3000 ft. 337057-201 REV.A											

Step 8 — Set Gas Input Rate

1. Jumper R and W thermostat connections to call for heat. (See Figure 11)
2. Check manifold orifices for gas leaks when main burners ignite.
3. Adjust gas manifold pressure. (Refer to conversion kit rating plate 337057-201).
 - a. Turn adjusting screw counterclockwise (outwards) to decrease manifold pressure or clockwise (inwards) to increase manifold pressure. (Figure 8)

NOTE: Gas valve regulator seal cap MUST be in place when checking input rate.

- b. When correct input is obtained, main burner flame should be clear blue, almost transparent. (See Figure 14) Be sure regulator seal cap is in place when finished.
4. Remove jumper across R and W thermostat connections to terminate call for heat.
 5. Turn furnace gas valve control switch or control knob to OFF position.

6. Turn off furnace power supply.
7. Remove manometer and replace manifold pressure tap plug. (See Figure 8)

NOTE: Use propane-gas-resistant pipe dope to prevent gas leaks. DO NOT use Teflon tape.

8. Turn furnace gas valve control switch or control knob to ON position.
9. Turn on furnace power supply.
10. Set room thermostat to call for heat.
11. Check manifold pressure tap plug for gas leaks when main burners ignite.
12. Observe unit operation through two complete heating cycles. See Sequence of Operation in furnace Installation, Start-up and Operating Instructions.
13. Set room thermostat to desired temperature.

Step 9 — Check Low Gas Pressure Switch Operation

The newly installed low gas pressure switch is a safety device used to guard against adverse burner operating characteristics that can result from low gas supply pressure. Switch opens at not less than 6.5 in. w.c. and closes at not greater than 10.2 in. w.c.

This switch also prevents operation when the propane tank level is low which can result in gas with a high concentration of impurities, additives, and residues that have settled to the bottom of the tank. Operation under these conditions can cause harm to the heat exchanger system.

This normally open switch closes when gas is supplied to gas valve under normal operating pressure. The closed switch completes control circuit. Should an interruption or reduction in gas supply occur, the gas pressure at switch drops below low gas pressure switch setting, and switch opens. Any interruption in control circuit (in which low gas pressure switch is wired) quickly closes gas valve and stops gas flow to burners.

When normal gas pressure is restored, the system must be electrically reset to re-establish normal heating operation.

Before leaving installation, observe unit operation through two (2) complete heating cycles. During this time, turn gas

supply to gas valve off just long enough to completely extinguish burner flame, then instantly restore full gas supply. To ensure proper low gas pressure switch operation, observe that there is no gas supply to burners until after hot surface igniter begins glowing.

Figure 14 – Burner Flame

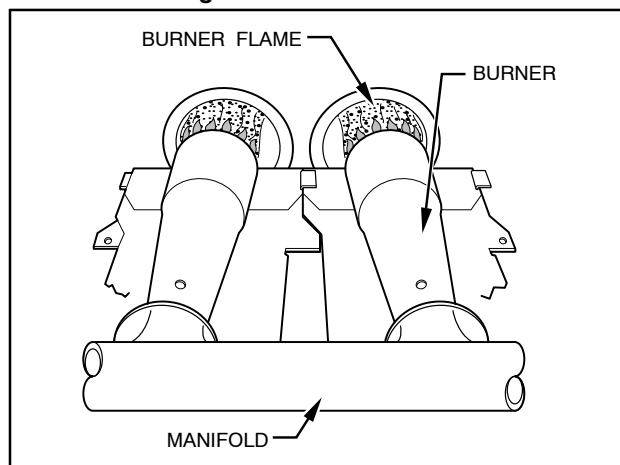

A89020

Step 10 — Label Application

1. Fill in Conversion Responsibility Label 337057-205 and apply to Blower Access Door of furnace as shown. (See Figure 15) Date, name, and address of organization making this conversion are required.
2. Attach Conversion Rating Plate Label 337057-201, see Figure 15 to Outer Door of furnace.
3. Apply Gas Control Conversion Label to gas valve: For single-stage gas valve apply label 337057-203 to gas valve. (Do not use 337057-202, which is similar)
4. Check for correct normal operating sequence of the ignition system as described in furnace Installation, Start-Up, and Operating Instructions.
5. Replace control access door, blower access door and outer door of furnace.

Figure 15 – Label Application

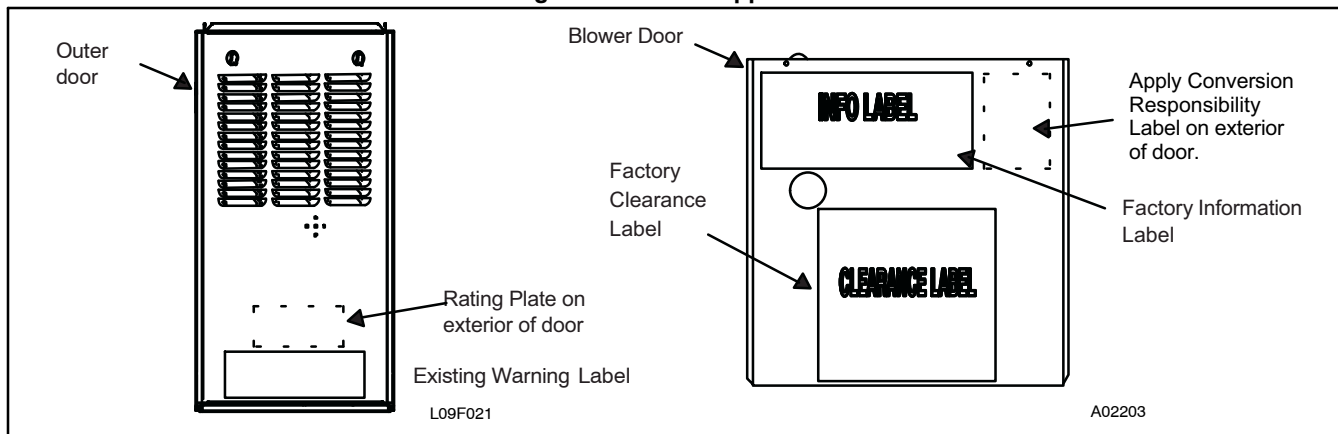

Illustrations and photographs are only representative. Some product models may vary.

**INSTALLATION
SECTION 2
INDUCED-COMBUSTION,
HOT-SURFACE IGNITION, TWO-STAGE
AND VARIABLE SPEED, 33.3-IN.
(846 MM) HIGH, NON-CONDENSING
FURNACES**

Two-Stage Models	Variable-Speed Models
F8MTL	F8MVL
G8MTL	G8MVL

Step 1 — Install Main Burner Orifices and Burner Spoiler Screws

1. Turn off furnace gas and electrical supplies.
2. Remove outer door.
3. Turn furnace gas valve switch to OFF position.
4. If furnace is oriented in a manner that the vent connector interferes with burner removal, remove vent connector from vent elbow inside the furnace. Support the remaining vent connector with temporary metal wire or straps to prevent damage to the remaining portions of the vent connector.

⚠ CAUTION

UNIT DAMAGE HAZARD

Failure to follow this caution may result in unit damage.

DO NOT re-drill burner orifices. Improper drilling may result in burns, out-of-round holes, etc. Obtain new orifices if orifice size must be changed. (See Figure 16)

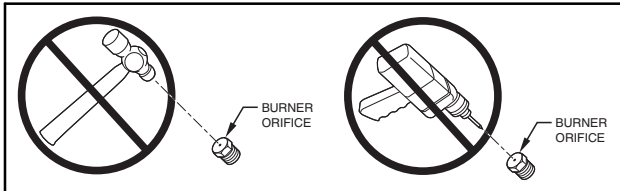

A96249

Figure 16 – Burner Orifice

NOTE: See Figure 17 for component location in upflow orientation. Re-orient component arrangement when furnace is installed in other positions.

5. Remove gas supply pipe from gas valve (if installed).
6. Disconnect wires from gas valve.
7. Remove the 2 screws on the left side that secure the manifold to the burner box.
8. Swing out manifold from burners then pull manifold out of right side of burner box. (See Figure 17)

⚠ CAUTION

UNIT OPERATION HAZARD

Failure to follow this caution may result in unit damage or improper operation.

Label all wires prior to disconnection when servicing controls.

9. Remove and discard orifices from manifold.

Gas input rate on furnace rating plate is for installations at altitudes up to 2000 ft. (609 M).

In the U.S.A.: the input rating for altitudes above 2000 ft. (609 M) must be reduced by 4 percent for each 1000 ft. (305 M) above sea level.

The Conversion Kit Rating Plate accounts for high altitude derate. See Figure 27.

Figure 17 – Component Location

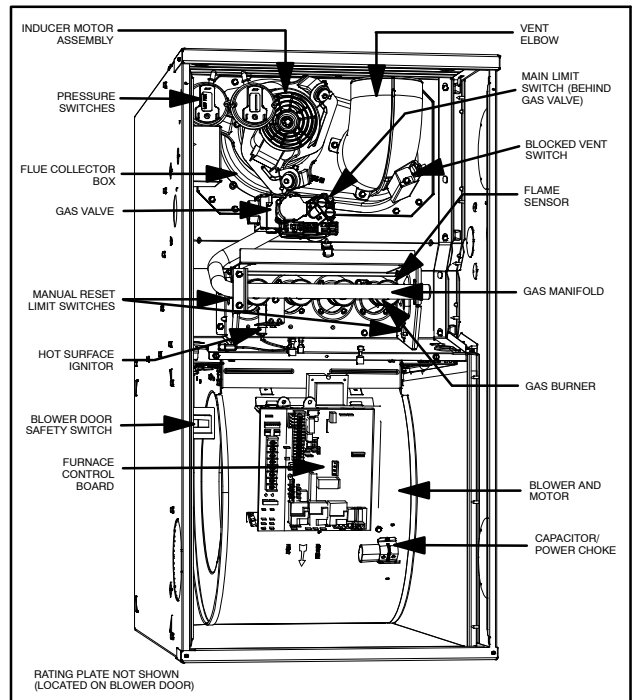

10. Install main burner orifices. Do not use Teflon tape. Finger-tighten orifices at least 1 full turn to prevent cross-threading, then tighten with wrench. There are enough orifices in each kit for largest furnace. Discard extra orifices.
11. To install burner spoiler screws, follow these steps:
 - a. Disconnect Hot Surface Igniter (HSI) wires from HSI.
 - b. Disconnect Flame Sensor wire from Flame Sensor.
 - c. Slide one-piece burner assembly out of slots on sides of burner box.
 - d. Remove the Hot Surface Igniter (HSI) and bracket from the burner assembly.
 - e. Remove flame sensor from the burner assembly.
 - f. Locate the dimple on each burner venturi tube (see Figure 18).

- g. Drill a 5/64-in. (2 mm) hole (supplied in kit) in each dimple.
- h. Install a spoiler screw in each drilled hole drilling as straight as possible.

Figure 18 – Location of Dimple for Spoiler Screw

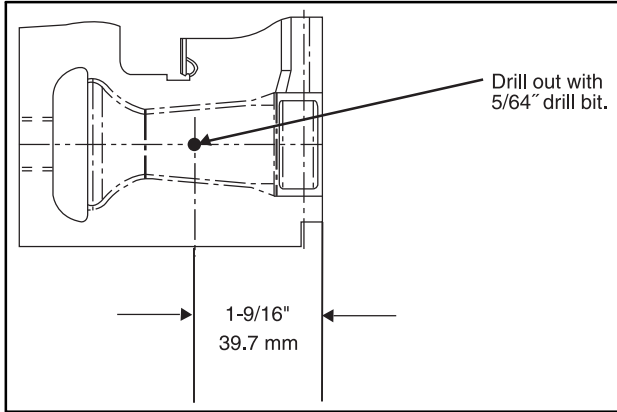

A06432

NOTE: Models F8MTL, G8MTL, F8MVL and G8MVL are supplied with NOx emissions–reduction devices necessary for use with Natural Gas in NOx emissions–regulated areas.

⚠ CAUTION

UNIT DAMAGE HAZARD

Failure to follow this caution may result in unit damage.

Furnace models F8MTL, G8MTL, F8MVL and G8MVL **MUST** have low NOx devices removed prior to operating furnace on propane gas.

12. For NOx device removal, follow these additional steps:
 - a. Remove the screw underneath the heat exchanger inlet that secures the NOx device in the heat exchanger. (See Figure 19)
 - b. Use a pair of needle nose pliers to remove the NOx device. Squeeze the sides of the device, if necessary, to remove from the heat exchanger.
 - c. Re–install screw in hole underneath heat exchanger inlet.

Figure 19 – NOx Device Location

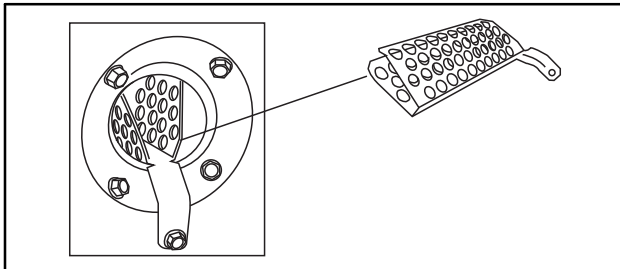

A02195

NOTE: It is very **IMPORTANT** to re–install the NOx bracket mounting screw.

- d. Repeat steps a thru c for each heat exchanger.
13. To reinstall burner assembly:

- a. Attach flame sensor to burner assembly.

Figure 20 – Igniter to Burner

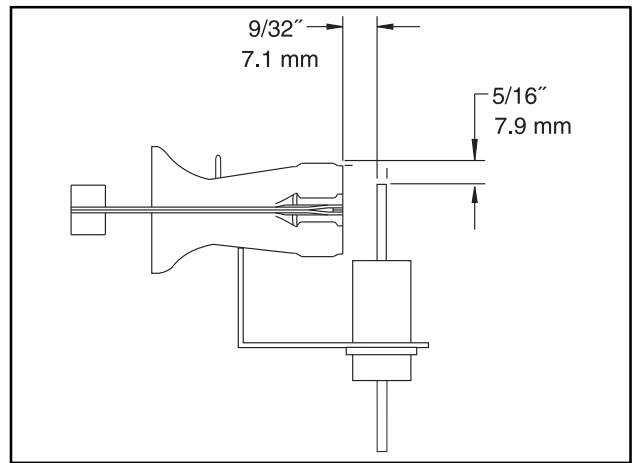

A05025

Figure 21 – Igniter to Burner

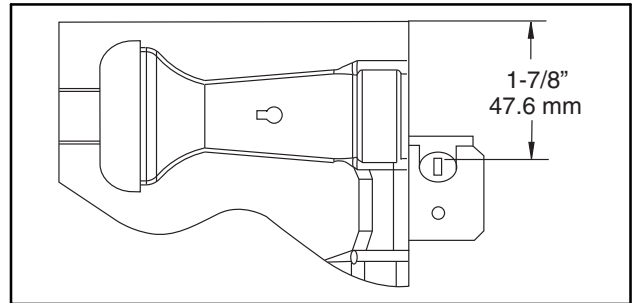

A05026

Figure 22 – Igniter to Burner

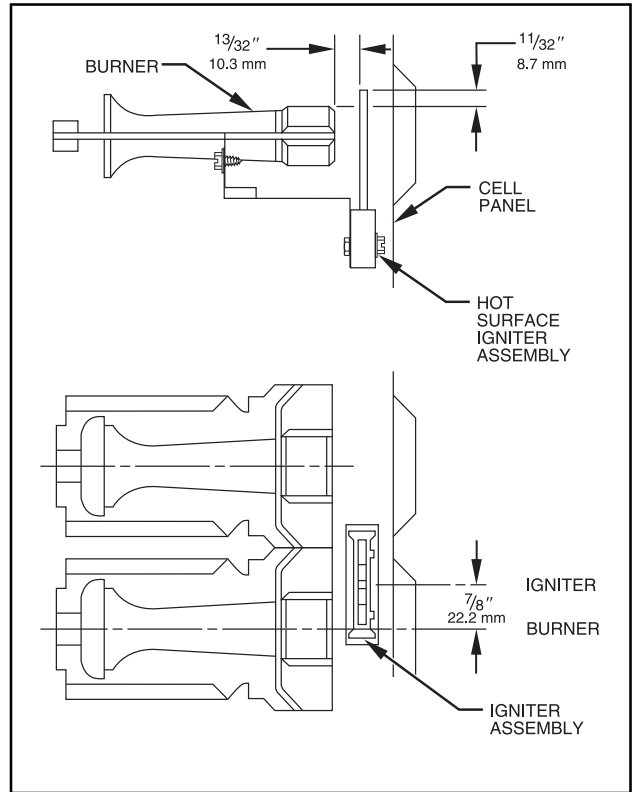

A93347

- b. Install HSI and bracket to burner assembly.
- c. Insert one–piece burner in slot on sides of burner box and slide burner back in place.
- d. Reattach HSI wires to HSI. Verify Igniter to Burner alignment. For Silicon Nitride igniters, See Figure 20 and Figure 21.

- e. Reattach Flame sensor wire to Flame Sensor.
14. Reinstall manifold by inserting right end of manifold into opening in right side of burner box.
15. Swing manifold into burner assembly and insert orifices into openings on burners.
16. Verify that orifices are fully inserted into burners and burners are fully seated in burner box.
17. Secure manifold to left side of burner box, verifying that green ground wire is reattached to burner box.
18. Reconnect wires to gas valve per the wiring diagram supplied with the unit.

NOTE: Failure to attach ground wire to gas manifold on burner box will result in loss of flame signal resulting in a no-heat condition.

NOTE: Use propane-gas resistant pipe dope to prevent gas leaks. DO NOT use Teflon tape.

Step 2 — Converting and/or Pre-Adjust Two-Stage Gas Valve

NOTE: For the two-stage furnaces with a Series G and Series J gas valve (see Figure 23), they **MUST have both regulator springs replaced and the gas valve MUST be pre-adjusted.**

For Figure 23

1. Be sure main gas and electrical supplies are turned OFF.

Figure 23 – Series G Gas Valve & Series J

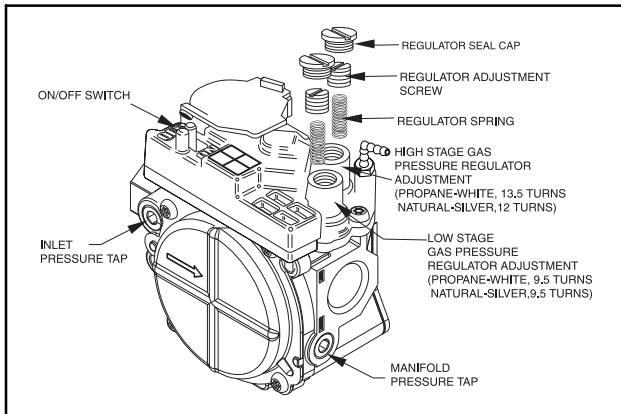

A05196

2. Remove both regulator seal caps. (See Figure 23)
3. Remove both regulator adjustment screws.
4. Remove both natural gas regulator springs (silver).
5. Install propane gas regulator springs (white).
6. Install regulator adjustment screws.
7. Turn **low-heat** stage adjusting screw **clockwise (inwards) 9.5 turns**. This will increase the manifold pressure closer to the low-heat set point.
8. Turn **high-heat** stage adjusting screw **clockwise (inwards) 13.5 turns**. This will increase the manifold pressure closer to the high-heat set point.

Figure 24 – LGPS Installed

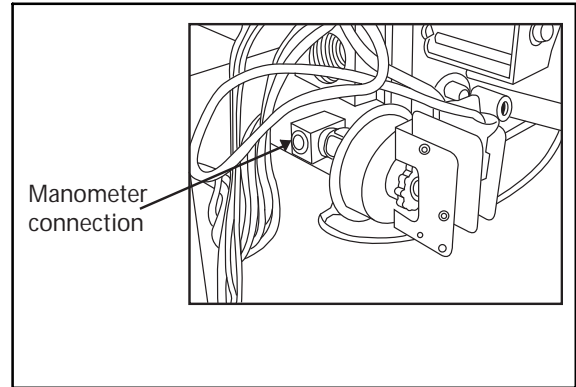

A05191

9. Do not install regulator seal caps at this time.
10. Go to Step 3.

Step 3 — Install Low Gas Pressure Switch (LGPS)

NOTE: The inlet gas pipe must be disconnected from valve so pressure switch can be installed.

NOTE: Use propane-gas-resistant pipe dope on all connections to prevent gas leaks. DO NOT use Teflon tape.

1. Be sure main gas and electric supplies to furnace are off.
2. Remove 1/8-in. (3 mm) pipe plug from inlet pressure tap on gas valve. (See Figure 23) DO NOT DISCARD 1/8-in. (3 mm) PLUG.
3. Apply pipe dope sparingly to one end of 1/8-in. (3 mm) brass male coupling (provided in kit) and install the doped end in 1/8-in. (3 mm) tapped opening in gas valve inlet pressure-tap. Tighten fitting with a small open-end wrench.
4. Apply pipe dope sparingly to opposite end of the 1/8-in. (3 mm) brass coupling (provided in kit). Install the female end of the female x female x male tee on the brass coupling. Tighten coupling finger tight. Use a small open end wrench for final tightening.
5. Apply pipe dope sparingly to male end of brass tee. Install propane low gas pressure switch (provided in kit) on male end of the female x female x male tee. Tighten switch finger tight. Use a small open-end wrench on base of pressure switch for final tightening. (See Figure 24)
6. Connect a manometer to the open end of the tee installed in the gas valve. (See Figure 24)
7. Apply pipe dope sparingly to end of inlet gas pipe and reconnect pipe to gas valve.

Step 4 — Check Inlet Gas Pressure

NOTE: This kit is to be used only when inlet gas pressure is between 11.5-in. wc and 13.6-in. wc.

For **Two-Stage** furnaces on the control board: Turn LHT switch on furnace control to ON. (See Figure 25)

For **Variable Speed** furnaces, perform the following on the control board: Turn setup switch SW1-2 on furnace control ON (See Figure 26).

1. Verify manometer is connected to the brass tee connected to the inlet pressure tap on gas valve. (See Figure 24)



CAUTION

UNIT DAMAGE HAZARD

Failure to follow this caution may result in unit damage.

DO NOT operate furnace more than one minute to check inlet gas pressure, as conversion is not complete at this time.

2. Turn on furnace power supply.
3. Turn gas supply manual shutoff valve to ON position.
4. Turn furnace gas valve switch to ON position.
5. Jumper R-W/W1 and R-W2 thermostat connections on the Two-Stage and Variable Speed furnace control. (See Figure 25 and Figure 26) The two-stage algorithm must be removed to force furnace to high heat operation.
6. When main burners ignite, confirm inlet gas pressure is between 11.5-in. wc and 13.6-in. wc.
7. Remove jumper across thermostat connections to terminate call for heat.
8. Turn furnace gas valve switch to OFF position.
9. Turn gas supply manual shutoff valve to OFF position.
10. Turn off furnace power supply.
11. Remove manometer.
12. Apply pipe dope sparingly to end of inlet gas pipe plug and install in unused end of 1/8-in. (3 mm) tee. Use a small back-up wrench on tee when tightening gas inlet pipe plug. (See Figure 23)

Step 5 — Modify Two-Stage and Variable-Speed Pressure Switch Wiring

1. Disconnect yellow wire from low-heat pressure switch LPS on inducer housing. Add 3/16-in. (8 mm) splice connector to this wire.
2. Connect uninsulated terminal of 6-in. (152 mm) yellow wire (provided in kit) to splice connector. Connect other end to C terminal on low-gas pressure switch LGPS.
3. Connect insulated terminal of 14-in. (356 mm) yellow wire (provided in kit) to N.O. terminal on low gas pressure switch LGPS. Connect other end to pressure switch LPS located on inducer housing.
4. Route yellow wires along wire harness. Secure with wire tie provided in kit. Go to Step 6.

Step 6 — Check Furnace Operation and Make Necessary Adjustments

1. Be sure main gas and electric supplies to furnace are off.
2. Remove 1/8-in. (3 mm) pipe plug from manifold pressure tap on downstream side of gas valve. (Figure 23)
3. Attach manometer to manifold pressure tap on gas valve. (See Figure 24)
4. Turn gas supply manual shutoff valve to ON position.
5. Turn furnace gas valve switch to ON position.
6. Check all threaded pipe connections for gas leaks.
7. Turn on furnace power supply.



WARNING

FIRE AND EXPLOSION HAZARD

Failure to follow this warning could result in personal injury and/or death.

NEVER test for gas leaks with an open flame. Use a commercially available soap solution made specifically for the detection of leaks to check all connections.

Step 7 — Set Gas Input Rate

The gas-input rate for propane is the same as for natural gas. See furnace rating plate for input rate. The input rate for propane is determined by manifold pressure and orifice size. Refer to the Conversion Kit Rating Plate 337057-204.

Gas input rate on furnace rating plate is for installations at altitudes up to 2000 ft. (609 M).

In the U.S.A., the input rating for altitudes above 2000 ft. (609 M) must be reduced by 4 percent for each 1000 ft. (305 M) above sea level.

The Conversion Kit Rating Plate accounts for the high altitude derate.

Step 8 — Set Gas Input Rate

For Two-Stage Furnaces:

1. Make sure LHT switch on furnace control is ON (See. Figure 25)
2. Jumper R and W/W1 thermostat connection on furnace control.
3. Check manifold orifices for gas leaks when main burners ignite. Go to Step 4.

Figure 25 – Furnace Control for Two-Stage Non-Condensing Furnaces

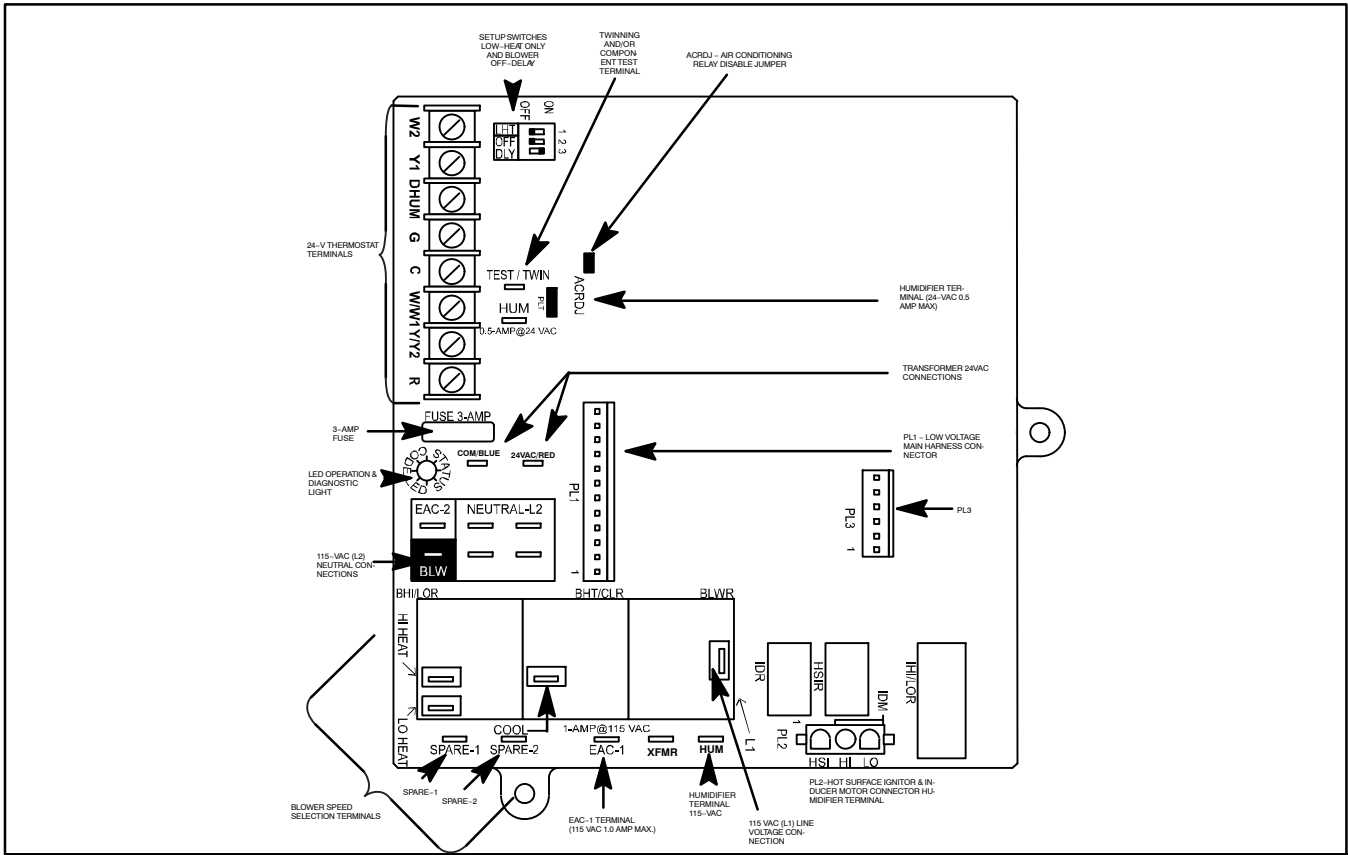
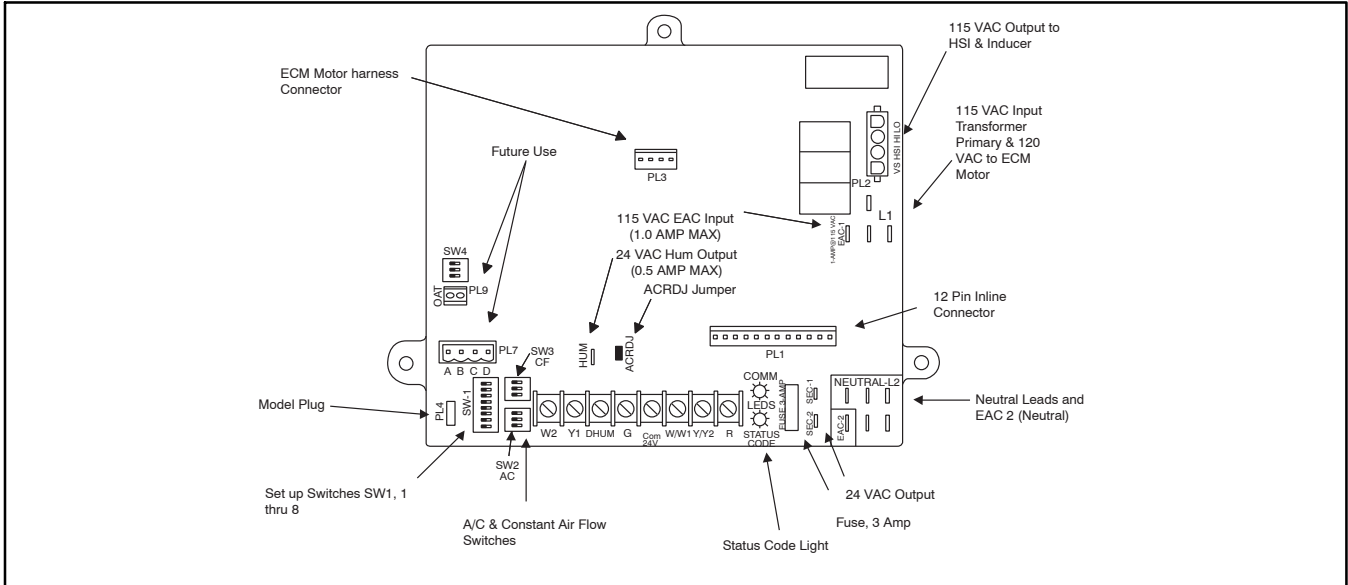

Figure 26 – Furnace Control for Variable Speed Non-Condensing Variable Speed Furnaces



A02018

For Variable Speed furnaces, perform the following on the control board:

1. Make sure Setup Switch SW1-2 on furnace control in ON (See Figure 26).
2. Jumper R and W/W1 thermostat connection on furnace control.
3. Check manifold orifices for gas leaks when main burners ignite. Go to Step 4.
4. Adjust gas manifold pressure.
 - a. Remove caps that conceal adjustment screws for gas-valve regulators. (See Figure 23)
 - b. Adjust low-heat input rate manifold pressure for propane gas. (See kit rating plate 337057-204, Figure 27.)

NOTE: Gas valve should already have been preadjusted, from prior steps for two-stage gas valve).

- c. Turn-low-heat adjusting screw (or 3/32 hex allen screw) counterclockwise (out) to decrease input rate or clockwise (in) to increase input rate.
- d. Jumper R, W/W1 and W2 thermostat connections on control. This keeps furnace in high-heat.
- e. Adjust high-heat input rate manifold pressure for propane gas. (See kit rating plate 337057-204, Figure 27.) Turn high-heat adjusting screw (or 3/32 hex allen screw) counterclockwise (out) to decrease input rate or clockwise (in) to increase input rate.
- f. Main burner flame should be clear blue, almost transparent.

- g. Remove jumper across R, W/W1 and W2 after high-heat adjustment.
- h. Replace caps that conceal gas-valve-regulator adjustment screws.
- 5. Turn setup switch LHT (two-stage) or SW-2 (variable speed) switch to OFF position.
- 6. Turn furnace gas valve switch to OFF.
- 7. Turn off furnace power supply.
- 8. Remove manometer and replace manifold pressure tap plug. (See Figure 23)

NOTE: Use propane-gas-resistant pipe dope to prevent gas leaks. DO NOT use Teflon tape.

- 9. Turn on furnace power supply.
- 10. Turn furnace gas valve switch to ON position.
- 11. Set room thermostat to call for heat.
- 12. Check pressure tap plug for gas leaks when main burners ignite.
- 13. When correct input is obtained, main burner flame should be clear blue, almost transparent. (See Figure 14)
- 14. Observe unit operation through two complete heating cycles. See sequence of operation in furnace Installation, Start-Up, and Operating Instructions.
- 15. Set room thermostat to desired temperature.

Step 9 — Check Low Gas Pressure Switch Operation

The newly installed low gas pressure switch is a safety device used to guard against adverse burner operating

characteristics that can result from low gas supply pressure. Switch opens at not less than 6.5 in. w.c. and closes at no greater than 10.2 in. w.c.

This switch also prevents operation when the propane tank level is low which can result in gas with a high concentration of impurities, additives, and residues that have settled to the bottom of the tank. Operation under these conditions can cause harm to the heat exchanger system. This normally open switch closes when gas is supplied to gas valve under normal operating pressure. The closed switch completes control circuit. Should an interruption or reduction in gas supply occur, the gas pressure at switch drops below low gas pressure switch setting, and switch opens. Any interruption in control circuit (in which low gas pressure switch is wired) quickly closes gas valve and stops gas flow to burners.

When normal gas pressure is restored, the system must be electrically reset to reestablish normal heating operation. Before leaving installation, observe unit operation through two complete heating cycles. During this time, turn gas supply to gas valve off just long enough to completely extinguish burner flame, then instantly restore full gas supply. To ensure proper low gas pressure switch operation, observe that there is no gas supply to burners until after hot surface ignitor begins glowing.

Figure 27 – Conversion Kit Rating Plate 337057-204

CONVERSION KIT RATING PLATE - INTERNATIONAL COMFORT PRODUCTS, LLC										
THIS APPLIANCE HAS BEEN CONVERTED TO USE PROPANE GAS FOR FUEL, REFER TO KIT INSTRUCTIONS FOR CONVERSION PROCEDURES. USE PARTS SUPPLIED BY MANUFACTURER AND INSTALLED BY QUALIFIED PERSONNEL. SEE EXISTING RATING PLATE FOR APPLIANCE MODEL NO. AND INPUT RATING.										
NOTE: Furnace gas input rate on rating plate is for installations up to 2000 ft. above sea level. In U.S.A. the input rating for altitudes above 2000 ft. must be derated by 2% for each 1000 ft. above sea level. In Canada the input rating must be derated by 5% for altitudes of 2000 ft. to 4500 ft. above sea level.										
KIT NUMBER: NAHA00801LP		FUEL USED: PROPANE GAS				INLET PRESSURE (min - max): 11.5 - 13.6 in. wc				
APPLIANCE MODELS		ALTITUDE OF INSTALLATION (FT. ABOVE SEA LEVEL) U.S.A. *								
		0 to 2000	2001 to 3000	3001 to 4000	4001 to 5000	5001 to 6000	6001 to 7000	7001 to 8000	8001 to 9000	9001 to 10000
G8MTL, G8MVL, F8MTL, F8MVL	ORIFICE NO.	55	1.30mm	1.30mm	1.25mm	1.25mm	1.25mm	56	56	56
	MNFLD PRESS	11.0 /	11.0 /	10.5 /	11.0 /	11.0 /	10.5 /	11.0 /	11.0 /	10.5 /
	HIGH / LOW	5.8	5.3	5.0	5.5	5.2	4.9	5.7	5.2	4.8
* For Canadian Installations from 2000 to 4500 ft use U.S.A. column 2001 to 3000 ft. 337057-204 REV. A										

Step 10 — Label Application

- 1. Fill in Conversion Responsibility Label 337057-205 and apply to inside of furnace as shown. Date, name, and address of organization making this conversion are required. See Figure 15 for location of conversion labels.

- 2. Attach Conversion Rating Plate 337057-204 near existing furnace rating plate.
- 3. Apply Gas Control Conversion Label:
 - a. Use Gas Control Conversion Label 337057-203.