

REFRIGERATED AIR DRYER TECHNICAL MANUAL

NC SERIES NON-CYCLING NCE MODELS 500 - 800



PATENT # 6,186,223

TABLE OF CONTENTS

PAGE

1.	INTRODUCTION	1
2.	ABBREVIATED WARRANTY	1
3.	REFRIGERATED DRYER NOMENCLATURE	2
4.	RECEIVING AND INSPECTION	3
5.	SAFETY AND OPERATION PRECAUTIONS	4
6.	PRINCIPLES OF OPERATION	7
7.	INSTALLATION AND INITIAL START-UP	16
8.	SCHEDULED MAINTENANCE	19
9.	TECHNICAIN MODE	22
10.	TROUBLESHOOTING	25
11.	WIRING DIAGRAMS	27
12.	GENERAL ARRANGEMENT	31
13.	PARTS IDENTIFICATION	32
14.	ENGINEERING SPECIFICATIONS	35

ZEKS Compressed Air Solutions
1302 Goshen Parkway
West Chester, Pennsylvania 19380

610-692-9100 800-888-2323
FAX 610-692-9192
WWW.ZEKS.COM

1. INTRODUCTION

ZEKS' Non-Cycling refrigerated air dryer removes moisture, oil vapor, and other contaminants from compressed air. These contaminants are detrimental to pneumatically operated equipment, controls, instruments, machinery and tools. This removal is accomplished by cooling the air with a refrigeration unit to a temperature at which moisture in the air is condensed and separated from the air stream. The temperature the air is cooled to, normally between 36° and 40°F (2° and 4°C), is known as dew point. This dryer can be easily installed into various pneumatic systems in which dry air is required or desired. Please refer to Principles of Operation for complete operating details.

- For warning label information with French translations, refer to pages 5 and 6.
- Pur obtenir l'information des etiquettes dangereuses avec la traduction en francais, s'il vous plait consulter les pages 5 and 6.

2. ABBREVIATED WARRANTY

ZEKS refrigerated dryers are warranted to be free from defects in material and workmanship for a period of 12 months from the original date of shipment from the factory. To allow the warranty to be in effect for 12 months from the date of equipment start-up, the Warranty Registration Card must be completed and returned to ZEKs. Alternately, the Warranty Registration Card may be completed online at www.zeks.com. The total warranty period cannot exceed 18 months from the original date of shipment from the factory.

Equipment must be installed and operated in accordance with ZEKs' recommendations. ZEKs liability is limited to repair of, refund of purchase price paid for, or replacement in kind at ZEKs' sole option, during the warranty time period stated above. IN NO EVENT SHALL ZEKs BE LIABLE OR RESPONSIBLE FOR INCIDENTAL OR CONSEQUENTIAL DAMAGES, even if the possibility of such incidental or consequential damages has been made known to ZEKs Compressed Air Solutions. In addition, the usual maintenance and replacement type products are not covered by this warranty.

HEAT EXCHANGERS

Dryers that utilize CFX heat exchanger technology (HSF, HSG, NCE, NCF & NCG) are covered for a total of 10 years from the original date of shipment from the factory. Following the standard warranty terms the available warranty is as stated below. The exchanger warranty applies to the replacement exchanger only and does not cover any labor expenses.

Prorated coverage of prices from date of shipment from the factory:

18 to 48 months	100%
49 to 60 months	70%
61 to 72 months	50%
73 to 84 months	30%
85 to 96 months	20%
97 to 120 months	10%

REFRIGERANT COMPRESSORS

A prorated warranty for the replacement of the refrigerant compressor will be extended to a maximum of 60 months (5 years) from the original date of shipment from the factory.

Following the standard warranty terms, the available prorated compressor warranty is as stated below. This prorated warranty applies to replacement compressor only and does not cover any labor expenses.

Prorated coverage of price from date of shipment from the factory:

19 to 24 months	70%
25 to 36 months	50%
37 to 48 months	30%
49 to 60 months	10%

Freight and labor coverage varies internationally. Refer to Distributor Warranty Guidelines for limitations and detailed explanation of warranty coverage.

The warranties expressed above are in lieu of and exclusive of all other warranties. There are no other warranties, expressed or implied, except as stated herein. There are no implied warranties of merchantability or fitness for a particular purpose, which are specifically disclaimed.

3. REFRIGERATED DRYER NOMENCLATURE

NOMINAL*

FLOW SCFM	TYPE	DESIGN SERIES	CONDENSER TYPE	VOLTAGE	OPTIONS
500, 600 700, 800	NC= Non-Cycle	E	A = Air Cooled W =Water Cooled	1 = 115-1-60 2 = 230-1-60 3 = 220-1-50 4 = 460-3-60 5 = 230-3-60 6 = 575-3-60 7 = 380-3-50 8 = 220-3-50 9 = 500-3-50	

O = STANDARD	O = STANDARD
G = GAUGE PACKAGE	F = COLD COALESCER
H = NEMA 4/12	P = Z-Trol™ Plus Controller
K = H + G	Z = NON-STANDARD
L = W + G	8 = DPC™- Plus Controller
W = WEATHERPROOF	

* Nominal Flows indicated are for 100°F inlet temperature, 100°F ambient temperature and 100 psig compressed air pressure.

4. RECEIVING AND INSPECTION

4.1 INSPECTION

Upon receiving your ZEKs air dryer, please inspect the unit closely. If rough handling has been detected, please note it on your delivery receipt, especially if the dryer will not be uncrated immediately. Obtaining the delivery person's signed agreement to any noted damages will facilitate any insurance claims.

4.2 UNPACKING AND HANDLING

WARNING

Under no circumstances should any person attempt to lift heavy objects without proper lifting equipment (i.e., crane, hoist, slings or fork truck). Lifting any unit without proper lifting equipment, may cause serious injury.

To facilitate handling during shipment, all dryer packages have been mounted on a base that provides for forklifting between two base channels. Forks should extend all the way through forklift channels to reduce unnecessary forces to the dryer during moving. Slings can be used to lift the crates, but spreader bars must be used to prevent the slings from exerting a force against the sides of the crates or the dryer.

5. SAFETY AND OPERATION PRECAUTIONS

Because an air dryer is pressurized and contains rotating parts, the same precautions should be observed as with any piece of machinery of this type where carelessness in operation or maintenance could be hazardous to personnel. In addition to obvious safety rules that should be followed with this type of machinery, safety precautions as listed below must be observed:

1. Only qualified personnel shall be permitted to adjust, perform maintenance or repair this air dryer.
2. Read all instructions completely before operating unit.
3. Pull main electrical disconnect switch and disconnect any separate control lines, if used, before attempting to work or perform maintenance on the unit.
4. Do not attempt to service any part while machine is in an operational mode.
5. Do not attempt to remove any parts without first relieving the entire air system of pressure.
6. Do not attempt to remove any part of the refrigeration system without removing and containing refrigerant in accordance with the EPA and local regulations.
7. Do not operate the dryer at pressures in excess of its rating.
8. Do not operate the dryer without guards, shields and screen in place.
9. Inspect unit daily to observe and correct any unsafe operating conditions.

OSHA Heading Descriptions

WARNING

"Warning" is used to indicate a hazardous situation which has some probability of death or severe injury. Warning should not be considered for property damage accidents unless personal injury risk is present.

CAUTION

"Caution" is used to indicate a hazardous situation which may result in minor or moderate injury.

NOTICE

"Notice" is used to indicate a statement of company policy as the message relates directly or indirectly to the safety of personnel or protection of property. Notice should not be associated directly with a hazard or hazardous situation and must not be used in place of "Danger," "Warning," or "Caution."

NOTICE

The user of any air dryer manufactured by ZEKS Compressed Air Solutions, is hereby warned that failure to follow the above Safety and Operation Precautions may result in personal injury or equipment damage. However, ZEKS Compressed Air Solutions does not state as fact, nor does it mean to imply, that the preceding list of Safety and Operating Precautions is all inclusive, and further, that the observance of this list will prevent all personal injury or equipment damage.

! DANGER
! PELIGRO



Air Under Pressure Will Cause Injury, Death Or Property Damage.

- Do Not Exceed Pressure Rating.
- Relieve Press. Before Servicing.
- Do Not Modify/Repair/Rework ASME Coded Pressure Vessels As Insurance Rating Affected.

! READ INSTRUCTION MANUAL !

L'air sous pression causera des blessures graves, des dégâts matériels et peut même entraîner la mort

Ne pas excéder le taux de pression

Relâcher la pression avant la mise en service de l'appareil

Ne pas modifier/réparer ou retravailler

Le taux de pression des vaisseaux est conforme aux recommandations de l'ASME (American Society of Mechanical Engineers) et peut être vérifié lors d'un contrôle.

LIRE LE MANUEL D'INSTRUCTIONS!

! DANGER
! PELIGRO



HIGH VOLTAGE Can Cause Severe Injury Or Death.

- Some circuits may be energized when switch is off.
- Disconnect and lockout ALL power sources before servicing.

! READ INSTRUCTION MANUAL !

La haute tension peut entraîner des blessures graves ou même la mort

- Certains circuits peuvent être chargés lorsque l'interrupteur est en position "fermé" (off)

- Déconnecter et verrouiller TOUTES les sources d'électricité avant la mise en service de l'appareil

LIRE LE MANUEL D'INSTRUCTIONS!

! DANGER
! PELIGRO

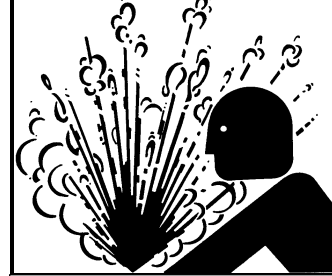

Air Under Pressure Will Cause Injury, Death Or Property Damage

- Relieve Press. Before Servicing.
- Condensate Drain Discharges Under Pressure.
- Drain Requires Periodic Cleaning (Service).

! READ INSTRUCTION MANUAL !

L'air sous pression causera des blessures graves, des dégâts matériels ou même la mort

Relâcher la pression avant la mise en service de l'appareil

Condenser les tuyaux de décharges sous pression

Les tuyaux doivent être nettoyés régulièrement (service)

LIRE LE MANUEL D'INSTRUCTIONS

ELECTRICAL CONNECTION BOX

- All Customer Connections To Be Made At This Location.
- See Attached Terminal Connection Diagram.
- Be Certain To Follow All NEC, State, Local and Other Applicable Codes During Installation.

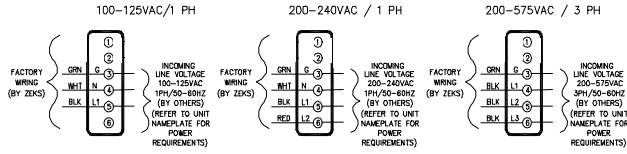

LA BOÎTE DE CONNEXION ÉLECTRIQUE CONTIENT DE LA HAUTE TENSION

- Éteindre et verrouiller Toutes les sources d'électricité avant la mise en marche de l'appareil
 - Une alarme à distance sera déclenchée lors de la mise en service de l'appareil
- LIRE LE MANUEL D'INSTRUCTIONS!

! DANGER

ELECTRICAL CONNECTION BOX

- Turn Off Power And Lock Out At ALL Sources Before Opening To Perform Service.
- Remote Alarm Contact Wiring Has Control Power From Separate Source.

! READ INSTRUCTION MANUAL !

WARNING

disconnect power from dryer. Always disconnect power from ALL sources before performing service.

! READ INSTRUCTION MANUAL !

ATTENTION !

Retirer les fusibles ne déconnectera pas l'électricité de l'appareil
TOUJOURS déconnecter toutes les sources d'électricité avant la mise en marche de l'appareil

LIRE LE MANUEL D'INSTRUCTIONS!

6. PRINCIPLES OF OPERATION

6.1 INTRODUCTION

ZEKS Non-Cycling dryers remove moisture from compressed air by cooling the air temperature to 36° (2.2°C). This causes vapors to condense into liquid droplets which can then be easily removed from the air. The major systems of the dryer which contribute to its operation are the Air System, the Moisture Removal System, the Refrigeration System and the Controls. The following paragraphs describe each of the systems in greater detail.

6.2 AIR SYSTEM

The Air System consists of the dryer components which are in contact with the compressed air. Referring to Figure 1 and following the bold "AIR FLOW," hot saturated air from the compressor enters the precooler/reheater where the air temperature is reduced prior to entering the chiller by the cool air exiting the air/moisture separator. This precooling allows for the use of a smaller refrigeration system. The air then goes into the chiller section where it is further cooled to the desired dew point by a thermal mass fluid. The temperature of the thermal mass fluid is maintained by the refrigeration circuit and controls. The air continues to the separator where moisture is removed, thereby, allowing the cool, dry air to return to the precooler/reheater to be heated by the incoming moist hot air. The air exiting the "reheater" portion of the dryer should be approximately 15°- 20°F lower than the inlet air temperature based on standard conditions at full rated flow.

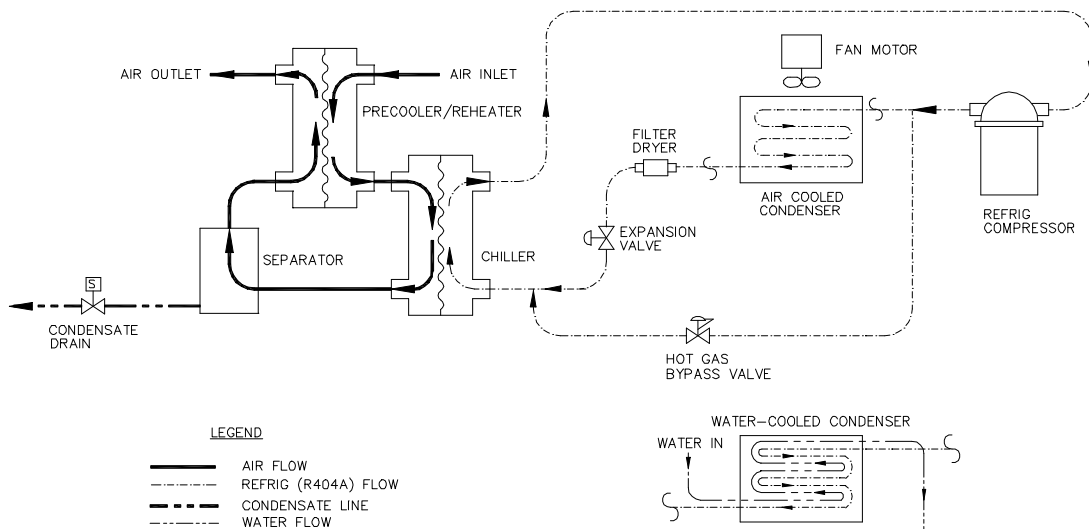

FIGURE 1
FLOW DIAGRAM

6.3 MOISTURE REMOVAL SYSTEM

Liquid droplets are removed from the air stream in the separator. As the air and liquid mixture passes through the separator it spins, slows down and then changes direction. This causes the condensate to fall out of the air stream and collect in the bottom of the separator. The collected liquid is removed from the separator by a solenoid valve. The solenoid valve is controlled by the microprocessor controller as described in Section 6. For adjustment please note the following:

- To obtain the optimum time values for operation of the solenoid drain valve, set the off-time to five minutes and the on-time five seconds via the controller. Refer to Section 6 for details.
- After running the unit under full rated flow for approximately 30 minutes, verify that when the solenoid drain opens, all of the accumulated liquid is discharged and then a small burst of air.
- If a small amount of liquid and a large amount of air is discharged, decrease the on-time setting or increase the off-time setting. If there is all liquid and no air has been discharged, increase the on-time setting or decrease the off-time setting.
- The on/off time settings will vary according to seasonal operating conditions. During the summer when more moisture is present in the air system a shorter on-time, increasing the valve opening frequency, is required. A longer valve off-time may be used during the winter months when moisture levels are lower.

6.4 REFRIGERATION SYSTEM

The Refrigeration System consists of all the components which handle refrigerant R404A. This is a hermetically sealed closed-loop system. Referring to Figure 1 and following the dot-dash "REFRIGERANT FLOW," refrigerant is shown leaving the chiller evaporator section, which in the process of removing heat is changed from a low pressure liquid to a low pressure gas. This gas enters the suction side of the compressor where it is compressed into a high pressure gas. The high pressure gas is cooled in the air or water cooled condenser section becoming a high pressure liquid. It then goes through a permanent filter-dryer that ensures the refrigerant system is free of contaminants. A thermostatic expansion valve meters the refrigerant into the chiller's evaporator. The pressure is reduced upon entering the chiller evaporator where it removes heat from the air system. When there are low loads (low air flow rate or inlet temperature), a hot gas valve by-passes the condenser and throttling device (capillary tube). This valve maintains a minimum evaporator pressure of 76 psig, which corresponds to a chiller temperature of 34°F, thus preventing freeze-up.

6.5 CONTROLS

ZEKS' 500-800NCE Refrigerated Compressed Air Dryers are equipped with the Digital Performance Controller (DPC™). This advanced microprocessor-based controller has been engineered by ZEKs exclusively for use with ZEKs' Compressed Air Dryers.

For NonCycling dryers, the DPC™ displays the temperature of the air at the coldest point in the air stream, providing an indication of the outlet pressure dew point of the dryer. In addition, the DPC™ permits monitoring of dryer parameters and enunciation of alarm conditions.

The list below summarize the features the DPC™:

- 1 X 16 Character Backlit LCD Display - Easy-to-read display provides continuous indication of dryer default parameter. Standard backlight permits viewing of critical information in low light environments.
- Electronic Drain with On/Off Time Adjustment: Included with DPC™-equipped HeatSink™ and NonCycle dryers is a solenoid drain valve. Control of the open and close time of the valve is set via the DPC™ Controller.
- Remote Start / Stop: DPC™-equipped dryers offer a unique remote start / stop feature. This feature allows the dryer to be operated via a remote user-supplied switch.
- Remote Alarm Contact: DPC™-equipped dryers include a remote alarm contact to provide indication of any of the dryers alarms described later in this manual. Contact rated for 2A / 120V max.

The DPC™ Controller features three levels of access. The default level CUSTOMER MODE permits adjustment of dryer parameters to address seasonal variations for drain timing. A protected TECHNICIAN MODE permits access to and manipulation of additional parameters to address the initial machine set up. A password protected FACTORY MODE is also included for use by ZEKs Service Personnel for troubleshooting the dryer.

All ZEKs Non-Cycling dryers include a Hot Gas By-Pass (HGBP) Valve to maintain suction pressure and temperature. This valve is necessary during low load applications to prevent freeze-up in the chiller section. The normal suction pressure for no load conditions should never drop below 76 psig. *This setting may need adjustment to match the load/ambient conditions encountered.

For HGBP Valve adjustment note the following:

- Turning the adjustment screw clockwise raises suction pressure and exchanger temperature.
- Turning the adjustment screw counter-clockwise reduces suction pressure and exchanger temperature.
- All adjustments should be made without air flow (load) on the dryer.

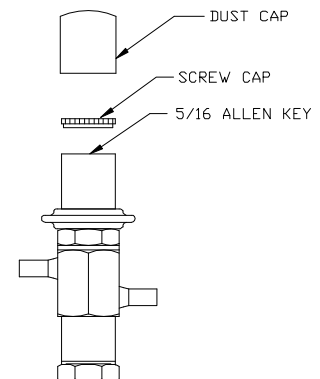

FIGURE 2 - HGBP VALVE

***This adjustment is not a procedure covered under warranty as it is typically required for application specific conditions.**

CAUTION

Do not rotate Hot Gas By-Pass valve adjustment nut fully clockwise. Full clockwise rotation may result in refrigerant compressor damage. Any suction pressure setting above 90 psig is not recommended.

ZEKS air cooled models utilize a microprocessor-controlled fan contactor to control the condensing temperature. This contactor controls the condensing temperature by cycling the fan based on refrigerant discharge pressure. When the unit reaches 275 psig, the microprocessor energizes the fan contactor that will run the fan until the discharge pressure is reduced to 195 psig. On 700NCE and 800NCE dryers, should the discharge pressure continue to rise, a secondary fan will energize at 335 psig and continue to operate until the discharge pressure has been reduced to 235 psig.

For water cooled models, a high pressure cut out switch is positioned near the water regulating valve. The switch is designed to open at 320 psig and close at 270 psig.

The DPC™ controller includes a digital readout for monitoring the discharge pressure of the refrigerant gas exiting the compressor. This reading will vary depending upon condenser type as indicated below:

- Air Cooled condensers with ambient temperatures between 80°F and 100°F, the refrigerant discharge gauge should read between 275 - 350 psig.
- Water cooled condensers utilize a water regulating valve. The water regulating valve comes pre-adjusted from the factory at 250 psig discharge pressure.

To compensate for water temperature variation, it may be necessary to adjust the water regulating valve to maintain a 250 psig discharge pressure. Adjustment can be done by rotating the adjusting screw counterclockwise for an increase in discharge pressure. For conditions where low water temperature and/or high water pressure are expected it is advisable to install a water pressure regulator ahead of the condenser.

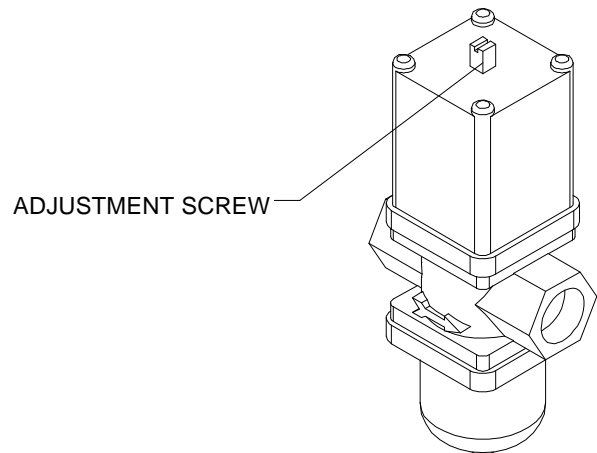

FIGURE 3
WATER REGULATING VALVE
Drawing 600562

WEATHERPROOF PACKAGE (OPTIONAL)

Dryers equipped with the optional Weatherproof Package are designed to operate in ambient conditions as low as 35 °F.

6.5.1 BASIC USER INTERFACE

The DPC™ display provides the user with the operating parameters and their corresponding values. When power is supplied to the dryer, the DPC™ will illuminate and default to the “Standby” mode, displaying the “Press ON” prompt.

The following illustration summarizes the keypad functions.

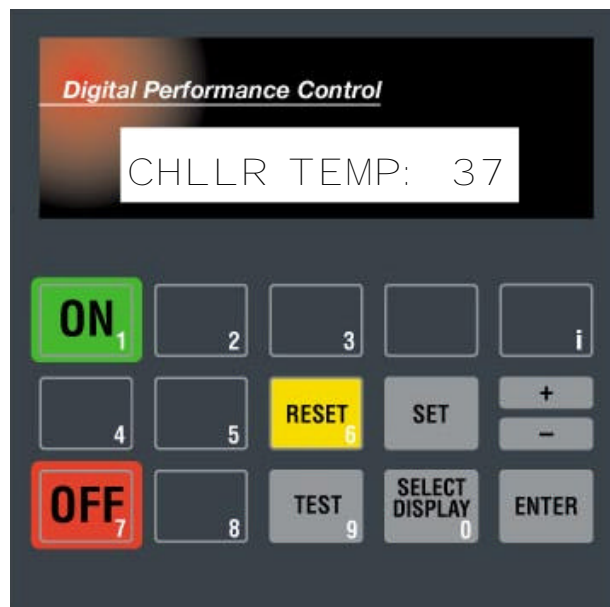

BUTTONS

- **ON**
Places the dryer "On Line"; Initiates drain timer; Energizes refrigeration system.
- **OFF**
Places the dryer "Off Line"; Stops all automatic functions.
- **SELECT DISPLAY**
Allows the user to cycle through the available displays. The last display selected will remain displayed as the default display.
- **+ / -**
Allows user to increase set point values. Set point values cycle through a fixed range. Also allows entering negative numbers in FACTORY MODE.
- **TEST**
Allows user to manually activate the drain solenoid valve.
- **RESET**
Pressing once clears the local alarm indication and de-energizes the remote alarm contact. Should the alarm condition persist, the alarm will return after the alarm inhibit time has expired.
- **SET**
Permits the adjustment of parameters in TECHNICIAN and FACTORY MODE. In CUSTOMER MODE, allows user to scroll back through displays.
- **ENTER**
Used to accept changed parameters and set point values.
- **i**
Restricted Level access for factory use only. Not used for basic dryer functions. Not to be used by customer or service technician.

6.5.2 DISPLAY PARAMETERS

The DPC™ Controller is capable of displaying a number of system parameters. The following summarizes the parameters that can be accessed by the user from the DPC™ Controller depending on the DPC™ version:

- Chiller Temperature (CHLLR TEMP): The Chiller Temperature is the temperature, in degrees Fahrenheit, of the air at the coldest point in the air circuit.
- Compressor Status (CMRSSLR): Displays whether the refrigeration compressor is “ON” or “OFF”.
- Discharge Pressure (P disch): Displays the discharge pressure of the refrigeration system.
- Suction Temperature (T suction): Displays the suction temperature, in deg. F, of the refrigeration system. This value is useful in determining superheat of the refrigerant. (DPC™-Plus Only)
- Suction Pressure (P suction): Displays the suction pressure, in psig, of the refrigeration system. (DPC™-Plus Only)
- Inlet Air Pressure and Temperature (P AIR IN / T AIR IN): Displays the temperature, in °F and pressure, in psig, of the inlet compressed air. (DPC™-Plus Only)
- Outlet Air Pressure and Temperature (P AIR OUT / T AIR OUT): Displays the temperature, in °F and pressure, in psig, of the outlet compressed air. (DPC™-Plus Only)
- Drain Interval (DRN INT): Displays the length of time, in minutes, between operation of the solenoid drain.
- Drain On (DRN ON): Displays the length of time, in seconds, that the solenoid drain is open.
- Cumulative Dryer Hours (CUM DRYER HR): Displays the length of time, in hours, that the dryer has been operational.

Depressing the SELECT DISPLAY button repeatedly scrolls through the above non-adjustable displays. The Customer Set Points appear at the end of the list and may be adjusted by the end user to match seasonal refrigeration and drain operation. These settings are as follows:

- Drain Interval (DRN INT)
- Drain On (DRN ON)

6.5.3 DRYER SET POINTS AND ALARMS

The DPC™ Controller has several user adjustable set points that are displayed at the end of the display parameter list. These set points allow the user to configure the dryer to operate according to site conditions. The controller is shipped from the factory with each parameter having its own default value. The following chart summarizes the parameters that may be adjusted by the user:

SETPOINT	Display Description	Parameter Range	Factory Setpoint	
			HeatSink	NonCycle
Drain Interval Time	DRN INT	3, 5, 10, 15, 20, 30, 60 min	3 MIN	3 MIN
Drain On Time	DRN ON	3, 5, 7, 10, 12, 15, 20, 30 sec.	10 SEC	10 SEC
Chiller Off Temperature	CHLLR TEMP	32°F - 50°F; 1 °F increments	34°F	INACTIVE

6.5.4 ADJUSTING SET POINTS

Accessing and manipulating each of the set points in the CUSTOMER MODE is accomplished as follows. The parameter is selected using the SELECT DISPLAY button. After scrolling through the displays, the “Cust Set Points” screen is displayed. The parameters after this screen may be adjusted by the user. Once the desired parameter is displayed, depressing the “+/-” button changes the set point. Once the new set point is displayed, depressing ENTER saves the set point. Exiting the Customer Set Point routine is accomplished by depressing the SELECT DISPLAY button until the END CUST SET PTS screen is displayed. The following example illustrates the keystrokes required to change the Drain Closed Time from the default value of 3 Minutes to 5 Minutes:

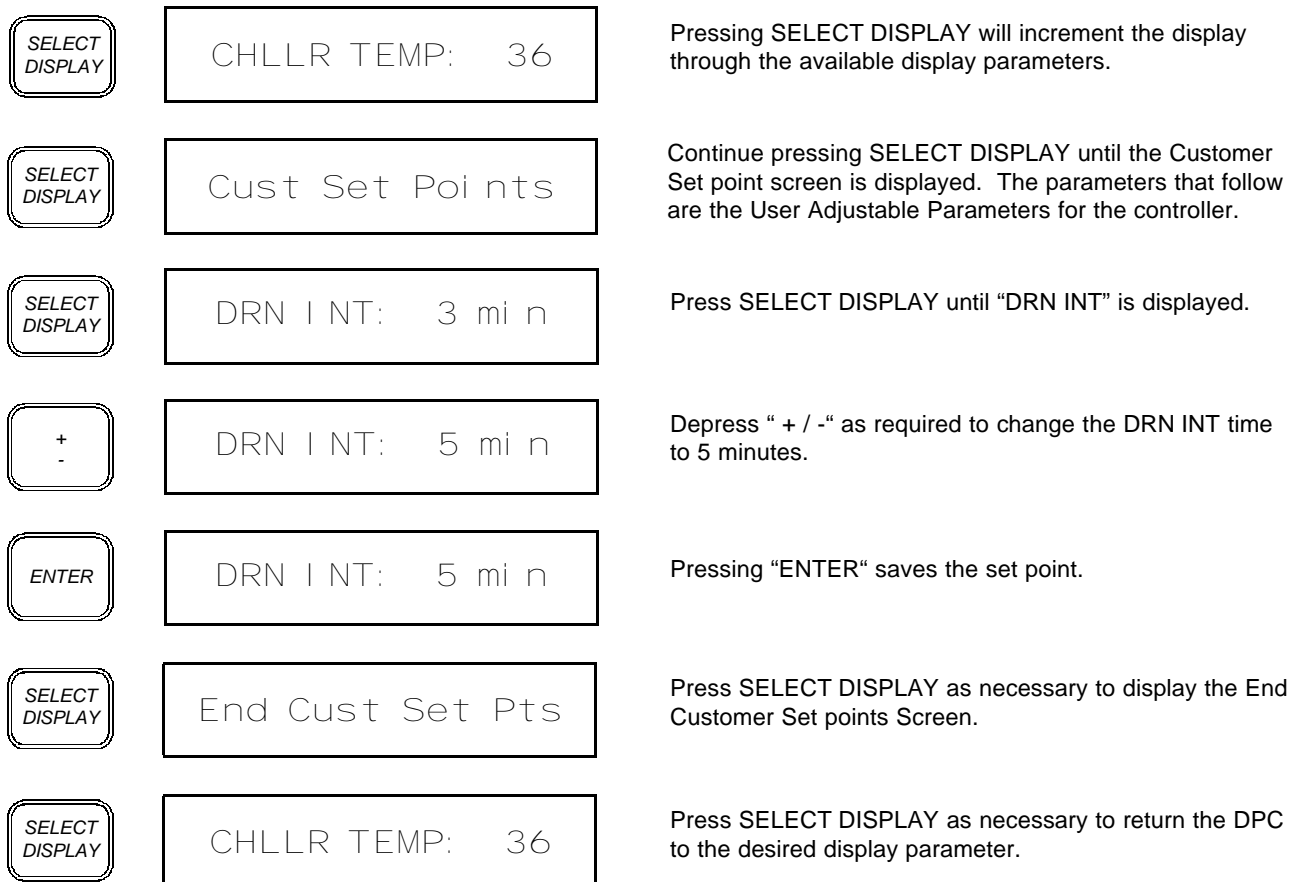

6.5.5 ALARMS AND THEIR FUNCTIONS

There are several alarms detected by the DPC™ to alert the user of an out of tolerance condition. Once each alarm is detected, a description of the alarm will appear in the screen and the remote alarm contact will close. Note that during the alarm condition, the SELECT DISPLAY button may be depressed to scroll through the available parameters. After approximately 30 seconds, the alarm screen will reappear, provided the alarm condition persists.

Alarm	Display	Alarm Set Point
HIGH PRESSURE CUTOUT	HI PRESS CO	See Table 1
HIGH TEMPERATURE ALARM	HITEMP ALRM	55 °F
LOW TEMPERATURE ALARM	LOTEMP ALRM	30 °F
HIGH DRAIN LEVEL ALARM	DRAIN LVL ALARM	N/A

The alarm names and a brief description of each are described in detail below. Note that some alarms will enunciate only after a prescribed alarm delay. Refer to the TECHNICIAN MODE section of this manual for factory default alarm delay periods.

HIGH TEMPERATURE ALARM (HITEMP ALARM)

When the air temperature at the inlet to the separator reaches the factory alarm set point, after an alarm delay, the alarm will be activated. This alarm condition that may not necessarily damage the dryer when subjected to long-term exposure. It may, however, have a significant impact on downstream processes and thus should be investigated upon detection. Note that this alarm will not shut down the dryer. This alarm will reset automatically once the alarm condition is rectified.

LOW TEMPERATURE SAFETY ALARM (LOWTEMP ALARM)

If the dryer chiller temperature falls below the factory set point and remains below this set point for the alarm delay time, the alarm routine will activate. This alarm condition may cause damage to the dryer when subjected to continuous or long-term exposure. Note that this alarm will shut down the dryer after a response time delay. This alarm will reset automatically once the alarm condition is rectified.

HIGH PRESSURE CUTOUT ALARM (HI PRESS CO)

If the discharge pressure of the refrigerant is determined to be above the set point, the alarm routine will activate. This alarm condition may cause damage to the dryer when subjected to continuous or long-term exposure. Note that this alarm will shut down the dryer after a response time delay. The operator must depress the RESET button in order to clear the alarm and restart the refrigeration system.

HIGH DRAIN LEVEL ALARM - OPTIONAL (DRAIN LVL ALARM)

On dryers equipped with the optional High Drain Level Alarm, should condensate rise to a predetermined level in the separator, a liquid level switch will signal the DPC and the High Drain Level Alarm will enunciate. In addition to indicating the alarm on the LCD and closing the remote alarm contact, the High Drain Level Alarm will open the solenoid drain in an attempt to correct the problem. The condition must be addressed to reset the dryer.

Parameter	R-22	R-404A	R-407C
FAN 1 ON	235 psig	275 psig	235 psig
FAN 1 OFF	195 psig	195 psig	195 psig
FAN 2 ON	265 psig	335 psig	265 psig
FAN 2 OFF	210 psig	235 psig	210 psig
HPCO (Air Cooled)	400 psig	450 psig	400 psig
HPCO (Water Cooled)	320 psig	320 psig	320 psig

TABLE - 1

6.6.6 START MODES

ZEKS dryers are capable of starting in one of three start modes. Note that to protect the refrigeration compressor from repeated rapid starts, the DPC™ is equipped with an anti-short cycle (ASC) delay. The ASC delay will countdown from the factory set point (see TECHNICIAN MODE). Only after the ASC delay has timed out will the refrigeration system operate. Below are brief descriptions of these various start modes.

6.6.6.1 Manual Mode

ZEKS dryers are shipped from the factory in the Manual Mode. After power is supplied to the dryer, the user will be presented with the ASC delay, followed by the "PRESS ON BUTTON" display. After the ASC delay has timed out, the dryer will only start once the ON button is depressed. In this configuration, to restart the dryer, the user must manually depress the ON button on the dryer's control panel.

6.6.6.2 Auto Restart Mode

After power is applied to the dryer, and once an anti-short cycle delay has timed out, the dryer will start automatically. In addition, this mode of operation allows manual control of the dryer via the ON & OFF pushbuttons. This is useful for applications where automatic restarting of the dryer is desired after a power failure has occurred.

6.6.6.3 Remote Automatic Mode

This mode of operation allows the user to control the dryer remotely and requires the installation of a customer-supplied contact. With power applied to the dryer and once the anti-short cycle delay has timed out, the dryer will start automatically once the switch is closed. In addition, this mode of operation allows manual control of the dryer via the ON & OFF pushbuttons.

7. INSTALLATION AND INITIAL START-UP

7.1 LOCATION AND MOUNTING

The dryer should not be located in an area where ambient temperature is likely to exceed 113°F (45°C) or be less than 50°F (10°C). The dryer must be located in an area that provides sufficient clearance from walls and other adjoining equipment to allow easy access for servicing and maintenance requirements. A minimum of 18 inches is required to allow free flow of air to the condenser inlet.

On installations with a relatively steady flow rate, the dryer is normally connected after the air receiver. If loads fluctuate widely, the dryer should be positioned ahead of the receiver and sufficient storage capacity downstream is necessary to prevent excessive air flow through the dryer.

When installed after any compressor that causes significant vibration or air pulsation, such as reciprocating compressors, proper vibration isolation and pulsation dampening devices should be added to protect the dryer.

NOTICE

Failure to comply to the above instructions may result in equipment malfunction and will void warranty.

NOTICE

Always use a backup wrench when making any threaded connection to the dryer. Failure to use a backup wrench may result in damaged tubing and components internal to the cabinet.

7.2 PIPING AND VALVES

Install piping, fittings and accessories as required for specific site conditions and requirements. Figure 3 indicates a typical piping arrangement for a refrigerated dryer, including dryer and filter bypasses. This figure can be used as a guide for valve and accessory placement in the system.

ZEKS 500 through 800 NCE models come factory installed with a drain isolation valve (D). The isolation valve permits maintenance of the automatic drain without isolating air flow to the dryer. To operate dryer, all valves shown in Figure 4 are to be closed except valves (B), (C) and (D). Valve (A) is used for bypass purposes and valve (E) is for test and manual drain purposes.

7.3 FILTRATION

To protect the air dryer from gross contamination associated with compressor oil and debris and ensure maximum dryer performance, a prefilter is recommended. Prefilters and afterfilters sized to your drying application can be provided by ZEKs and are available factory installed. Call your local distributor to select the filter that best suits your filtration requirements. In addition to air filtration, condensate discharge oil/water separators are also available to address stringent EPA regulations.

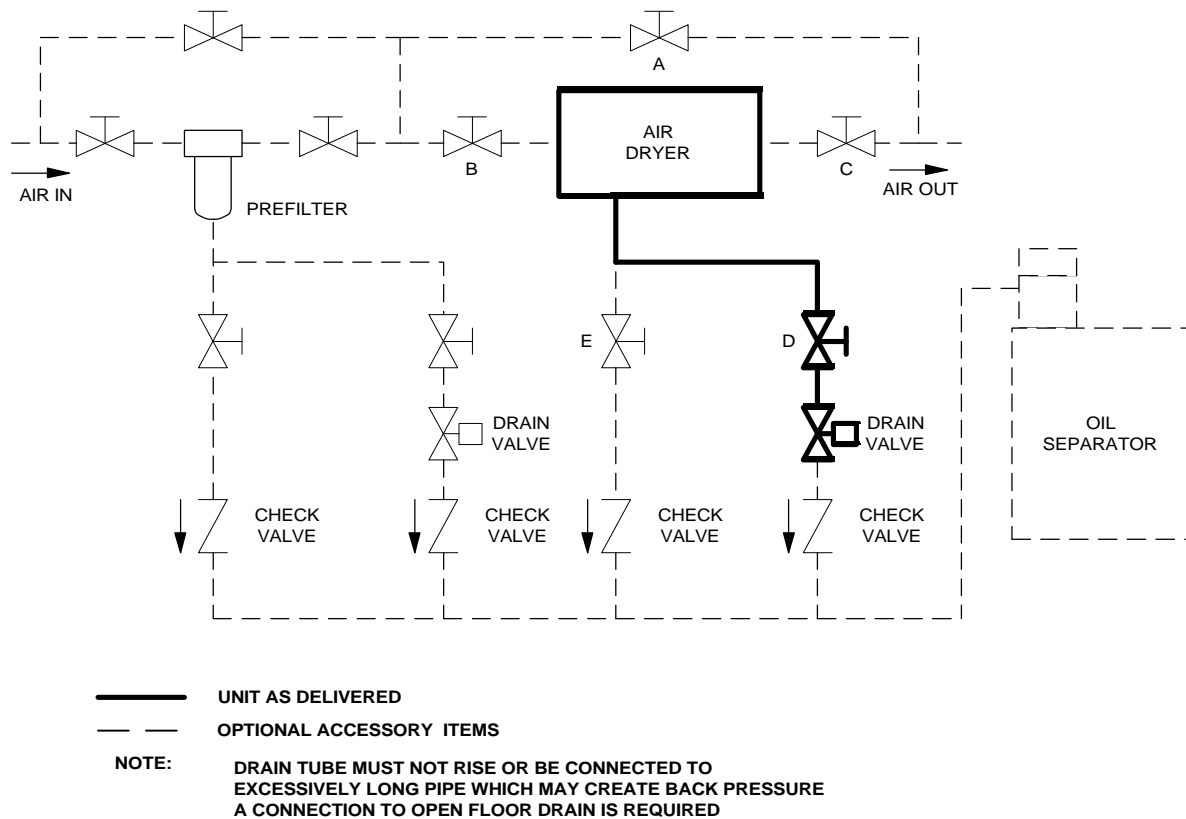

FIGURE 4
TYPICAL PIPING ARRANGEMENT

7.4 ELECTRICAL CONNECTION

Equipment is available in various electrical configurations. All customer connections can be made at the terminal connections located in the customer electrical connection box on the rear of the dryer. (Refer to General Arrangement and appropriate Wiring Diagrams.)

A suitable fused disconnect switch or circuit breaker, in accordance with national and local code requirements, is recommended for all ZEKs equipment. Refer to the Engineering Specifications Section for voltage requirements and load.

CAUTION

Never wire directly or connect any additional wires to the compressor junction box. This will cause severe system malfunction.

7.4.1 ZEKs dryers can be configured for three variations of start modes: Manual Mode, Automatic Mode and Remote Mode. The instructions below describe the methods to configure the dryer for a particular Start Mode.

A) Manual Mode (Factory Default) - No modification required to operate dryer in Manual Mode. Once power is applied, dryer can be started or stopped by depressing the local ON / OFF pushbuttons located on the front panel.

B) Auto Restart Mode - Auto Restart Mode permits the dryer to start after a brief delay once power is applied to the dryer. In TECHNICIAN MODE, changing the Auto Restart parameter from the default “N” to “Y” using the SET button enables this mode of operation. Note that the dryer’s touch pad will still affect dryer operation. Depressing the OFF button will de-energize the refrigeration compressor and all other electrical components. After the OFF button has been depressed, the user must depress the ON button to permit the dryer to operate.

C) Remote Mode - Remote Mode allows the dryer to be turned ON or OFF via a remote switch supplied by the customer. This mode will work regardless of the setting for Auto Restart. The dryer must be powered on for this feature to take effect. To enable this feature:

- Install N.O. remote switch as indicated on the appropriate wiring diagram.
- Customer-supplied contact should be rated at 1A at 24V. To operate dryer, close switch or contact and allow dryer to start after an initial delay. The local On / OFF pushbuttons may also be used at any time after contact closure.

7.5 INITIAL START-UP

NOTICE

For water cooled models, the water valve must be manually opened to ensure that the condenser is full of water prior to start-up.

7.5.1 START- UP SEQUENCE

- Apply power to dryer. LCD Panel will illuminate. The Anti-Short Cycle delay will commence counting down.

NOTICE

After installation or a prolonged shutdown, start the dryer with no air load (no air flow). This enables the dryer to reach its proper operating temperature in the shortest time possible (typically within 5 minutes for NonCycle™ dryers).

- Start Dryer, using one of the following methods, depending on Start Mode setting:

Manual Mode - Press the ON pushbutton.

Auto Restart Mode - No additional action required

Remote Automatic Mode - Close the remote contact.

- For NonCycle dryers, after the initial delay has timed out, the compressor is energized. The suction pressure gauge will typically pull down between 76 and 85 psig. The Hot Gas By-Pass Valve may require adjustment on start-up. Refer to dryer's Technical Manual for details.

After 5 minutes, **slowly** introduce air flow to the dryer.

After the alarm delay, provided the Chiller Temperature is greater than the HIGH TEMPERATURE ALARM set point, the dryer will go into HIGH TEMPERATURE ALARM. The LCD panel will indicate the alarm and the refrigeration system will continue to operate. Pressing the SELECT DISPLAY button will permit viewing of the available dryer parameters during this alarm condition. Note that the alarm condition screen will reappear after approximately 30 seconds until the alarm condition is cleared.

The CHILLER TEMPERATURE will gradually drop as indicated on the display. Once the temperature falls below the HIGH TEMPERATURE ALARM set point, the alarm will reset and the LCD panel will return to its default display.

Drain settings should be checked as described earlier in this manual and the dryer's Technical Manual.

8.0 SCHEDULED MAINTENANCE

8.1 INTRODUCTION

ZEKS NonCycle refrigerated air dryers require little maintenance. These dryers utilize hermetically sealed compressors which do not require any lubrication. Fan motors require lubrication at both oil ports every six months. ZEKs recommends component inspection and service at regular intervals to obtain maximum performance from your dryer.

8.2 REFRIGERANT CONDENSER

ZEKS dryers are equipped with an ambient air filter designed to protect the condenser from dirt and debris that can accumulate on the condenser. For proper operation, it is imperative that this filter be inspected and cleaned on a regular basis. Annual replacement of the filter is recommended. For applications where excessive dirt, dust or debris is encountered, more frequent inspection and cleaning may be required.

8.3 CONDENSATE DISCHARGE SYSTEM

On a minimum of a monthly basis, the operation of the automatic drain should be checked. The drain should be removed and cleaned as well to ensure no debris from the system is trapped inside the strainer. Figure 5 illustrates the drain assembly. To clean the drain, turn the Isolation Valve to the off position. Be sure the valve is depressurized. Carefully remove the Strainer End Cap and remove the Strainer. Clean the Strainer and remove any debris that is evident in the valve. Replace the Strainer and reinstall the Strainer End Cap. Carefully open the isolation valve and inspect the Strainer End Cap for leaks. Tighten as required.

WARNING

If your dryer is installed without a drain isolation valves (filter stop), failure to depressurize the dryer may result in serious injury. Do not remove the drain valve without depressurizing the unit.

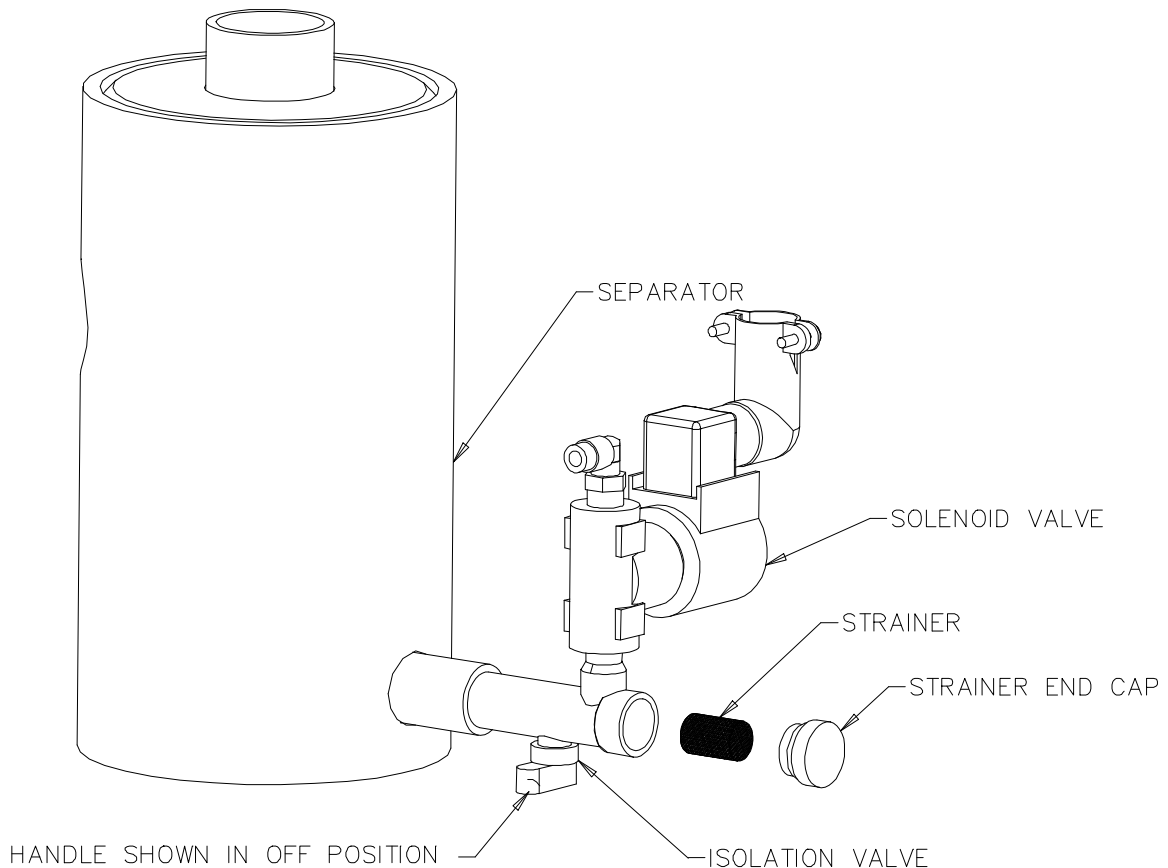
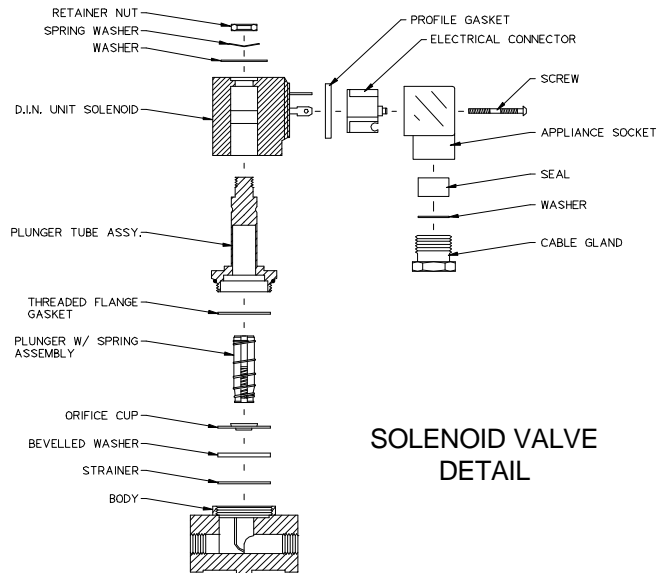

FIGURE 5
DRAIN DETAIL
DRAWING 737486

SOLENOID VALVE

- Loosen connector screw to allow the electrical connector assembly to be removed from the D.I.N. unit solenoid.
- Remove retainer nut and separate the valve body from the D.I.N. unit solenoid.
- Unthread the plunger tube assembly in a counter-clockwise direction until plunger separates from valve body.
- Clean beveled washer, threaded gasket, spring assembly and strainer with soap and water. Do **NOT** use solvents of any kind, as failure to the seals will occur. Be especially careful to clean the center brass orifice and the rubber gasket orifice on the orifice cup with a straight pin.
- Reassemble all drain components after the drain has been cleaned and inspected. Reposition the orifice hole on the rubber gasket of the orifice cup in the line and closest to the arrow indicated on the valve body.
- Reassemble valve and install in reverse order as described above.



CAUTION

Failure to periodically check and clean drain valve may result in drain becoming clogged. Should this occur, moisture remaining within separator may travel downstream of dryer.

9.0 TECHNICIAN MODE

The DPC™ provides a protected TECHNICIAN MODE to manipulate several parameters not accessible by the typical operator. This mode also permits viewing of the factory settings to aid in troubleshooting of the dryer. Below is a list of parameters that can be accessed and manipulated by the technician in the TECHNICIAN MODE:

Parameter	Display	Set Point
SOLENOID DRAIN ENABLE	DRAIN ENABLE	ON (or OFF)
CRANKCASE HEATER DELAY	CCH DLY	0 (or 2,4,8,12 hours)
AUTO RESTART ENABLE	AUTO RESTART	N (or Y)

In TECHNICIAN MODE, the following parameters can be viewed but not changed:

Parameter	Display	Set Point
OPERATING MODE	OP MODE	HS or NC
REFRIGERANT	REFRIG	22 or 404 or 407
CONDENSER TYPE	COND	AC OR WC
OPERATING TEMPERATURE DIFFERENTIAL	T OP DIFF	4
SHORT CYCLE DELAY	SHT CYC DLY	3
HIGH PRESSURE CUTOUT	HPCO	See Table-1
HIGH PRESSURE CUTOUT DELAY	HPCO DLY	10
LOW PRESSURE CUTOUT	LPCO	See Table-1
LOW PRESSURE CUTOUT DELAY	LPCO DLY:(10)	10
HIGH TEMPERATURE ALARM	HITEMP ALRM	55
LOW TEMPERATURE ALARM	LOWTEMP ALRM	30
LOW TEMPERATURE ALARM DELAY	LOTEMP DLY	120
DISCHARGE PRESSURE TRANSDUCER	Pd TRANS	Y (N)
SUCTION PRESSURE TRANSDUCER	Ps TRANS	N (Y)
SUCTION TEMPERATURE PROBE	Ts Probe	N (Y)
FAN 1 ON PRESSURE	FAN1 ON	See Table-1
FAN 1 OFF PRESSURE	FAN1 OFF	See Table-1
FAN 2 ON PRESSURE	FAN2 ON	See Table-1
FAN 2 OFF PRESSURE	FAN2 OFF	See Table-1

9.1 ENTERING TECHNICIAN MODE

WARNING

TECHNICIAN MODE should only be entered by qualified service personnel. Altering the set points in TECHNICIAN MODE will have a significant effect on the operation of the dryer. Incorrect set points may damage dryer and cause potential serious injury.

To enter the TECHNICIAN MODE, perform the following keystrokes:



Pressing the “2” and “3” buttons simultaneously enters the TECHNICIAN MODE.



Depressing SELECT DISPLAY scrolls through the available parameters. The first three parameters viewed are adjustable in TECHNICIAN MODE.

The DRAIN ENABLE parameter determines whether the DPC™ shall control an electronic solenoid drain valve. A value of “ON” will permit the DPC™ to control the drain valve. A value of “OFF” will disable this feature. This would be suitable for servicing the drain valve or if an independent no air loss drain is to be used with the dryer. To change the DRAIN ENABLE set point from the displayed set point, perform the following. Otherwise, depress the SELECT DISPLAY button to advance to the next adjustable parameter:



For parameters with “ON / “OFF” or “Y” / “N” choices, the set point is changed using the SET button. Pressing the SET button changes the Drain Enable from ON to OFF.



Depressing ENTER saves the selected set point.



Depressing the SELECT DISPLAY button advances to the next adjustable parameter for the Crankcase Heater Delay. This parameter must not be altered unless instructed by ZEKs Service personnel.

NOTICE

The Crankcase Heater Delay set point must not be altered unless directed by ZEKs Service Personnel. Improperly altering the set point may result in damage to the dryer. Contact ZEKs Compressed Air Solutions before altering the default set point.

The AUTO RESTART feature permits the dryer to operate once power is applied to the dryer without requiring operator intervention. This would be desirable should the user wish to have the dryer restart automatically after a power outage. To change the AUTO RESTART set point from “N” (NO) to “Y” (YES), perform the following. Otherwise, depress the SELECT DISPLAY button to advance to the next display:



Depressing the SELECT DISPLAY button advances to the next adjustable parameter for the Auto Restart feature.



Depressing the SET button changes the AUTO RESTART parameter from “N” to “Y”.



Depressing ENTER saves the selected set point.

WARNING

Changing the AUTO RESTART feature to “Y” will permit the dryer to operate automatically once power is applied and after a brief delay. Proper warning signs should be affixed to the dryer to alert users and service personnel that dryer may start without warning. Failure to do so may result in serious injury.



Depressing the SELECT DISPLAY button displays the END TECH SET PTS display.

The remaining non-adjustable parameters may be viewed by depressing the SELECT DISPLAY button as required to arrive at the desired display.

NOTICE

To exit the TECHNICIAN MODE at any time, depress the “BLANK” button located above the SET button to return to the CUSTOMER MODE.

9.2 ALARM LIST

At the end of the list of non-adjustable parameters, the DPC™ displays a list of the most recent 20 alarm conditions. This list can facilitate troubleshooting the dryer



At the end of the list of parameters, depressing the SELECT DISPLAY button displays the beginning of the ALARM LIST.



Depressing the SELECT DISPLAY button displays the alarms that the dryer has experienced, with the most recent alarm displayed first. The actual display will depend on the most recent alarm detected by the DPC.



The list of alarms can be scrolled by depressing the SELECT DISPLAY button as needed. At the end of the alarm list, the END ALARM LIST screen is displayed.



Depressing the SELECT DISPLAY list displays the ALARM LIST screen at the top of the ALARM LIST.

The Alarm List will repeat as long as the SELECT DISPLAY button is depressed. To EXIT the ALARM LIST, perform the following:



Depressing the BLANK button (located above the SET button) returns the controller to the top of the TECHNICIAN MODE.



Depressing the BLANK button again returns the controller to the default display of the CUSTOMER MODE.

10. TROUBLESHOOTING

10.1 INTRODUCTION

ZEKS dryers are designed for reliable, trouble-free operation. In the event of any dryer malfunction, the guide below has been developed to facilitate problem identification and corrective actions.

WARNING

An air dryer always operates under pressure. Any maintenance procedure that involves disassembly of pipe fittings, valves or any other components requires the dryer be isolated from the compressed air stream and fully depressurized.

WARNING

Prior to working on the unit, make sure that all circuit breakers or disconnected switches are tagged "Out of Service."

10.2 PROBLEM / ACTION GUIDE

PROBLEM	SYMPTOM(S)	POSSIBLE CAUSE	CORRECTIVE ACTION
Moisture down stream	Dryer is properly cooling air stream (Check Chiller. Temp on controller)	Drain failure or timer adjustment is required	Depress "TEST" button - if drain valve operates then adjust timing (See Section 6) Depress "TEST" button - if DRAIN TEST is displayed but valve does not open, ensure wiring connections are secure and power is being applied to the solenoid coil. If valve continues not to open, clean as described in Maintenance Section of this manual. Depress "TEST" button - if display does not indicate DRAIN TEST, contact distributor.
		Excessive flow	Check inlet and outlet pressures and system design capacity.
		Dryer by-pass valve not closed	Correct cause of excessive flow. Close by-pass valve
	Inlet and outlet temperatures are the same.	No power to the dryer	Check power supply and fuses/circuit breakers
		High suction pressure	Check and clean ambient air filter.
		Refrigerant leak	Check suction pressure gauge if reading is 0 psig, turn dryer off and contact your distributor
		Compressor <u>not</u> running and fan is running	Check and clean ambient air filter. Check ambient temperature and reduce below 113°F

PROBLEM	SYMPTOM(S)	POSSIBLE CAUSE	CORRECTIVE ACTION
Moisture down stream	Inlet and outlet temperatures are the same.	Compressor and fan <u>not</u> running.	Check Chiller Temperature Check MAIN CONTROL fuse.
		Compressor and fan not running. Controller indicates compressor is ON.	Compressor relay may be bad, replace relay Check for loose wire connections at contactor or loss of power at control board Defective control board - replace as necessary Contact your local distributor for further assistance.
	Compressor and fan are running, exchanger temp high, pump not running	Defective Pump	Contact your local distributor for further assistance.
Apparent controller display malfunction	Display Blank	Blown Fuse	Check Fuses
		Board Failure	Contact your local distributor for further assistance.
	Unrealistic temperature displayed	Probe loose, off connection or defective probe	Inspect probe cable and terminal connection Replace probe
	Erratic or inaccurate temperature readings	Probe not completely in thermal well	Inspect probe and check readings against independent source (eg. temperature analyzer/pyrometer/ice bath) both in temperature well and to ambient
		Defective probe	Replace probe
Unrealistic pressure displayed	Transducer loose, off connection or defective transducer	Inspect transducer cable and terminal connection Replace transducer	
High pressure drop across dryer	Outlet pressure substantially lower than inlet pressure System operating temperature is above 32°F	Inlet and outlet valves not completely open	Open valves
		Inlet and outlet filters blocked up	Change filter elements
	Outlet pressure substantially lower than inlet pressure System operating temperature is below 32°F	Compressor relay / contactor stuck.	Replace relay / contactor.
		DPC relay bad	Replace relay
		Probe not completely in thermal well	Inspect probe and check readings against independent source (eg. temperature analyzer/pyrometer/ice bath) both in exchanger well and to ambient
		Problem persists	Turn dryer off and consult your local distributor for further assistance

11. WIRING DIAGRAMS

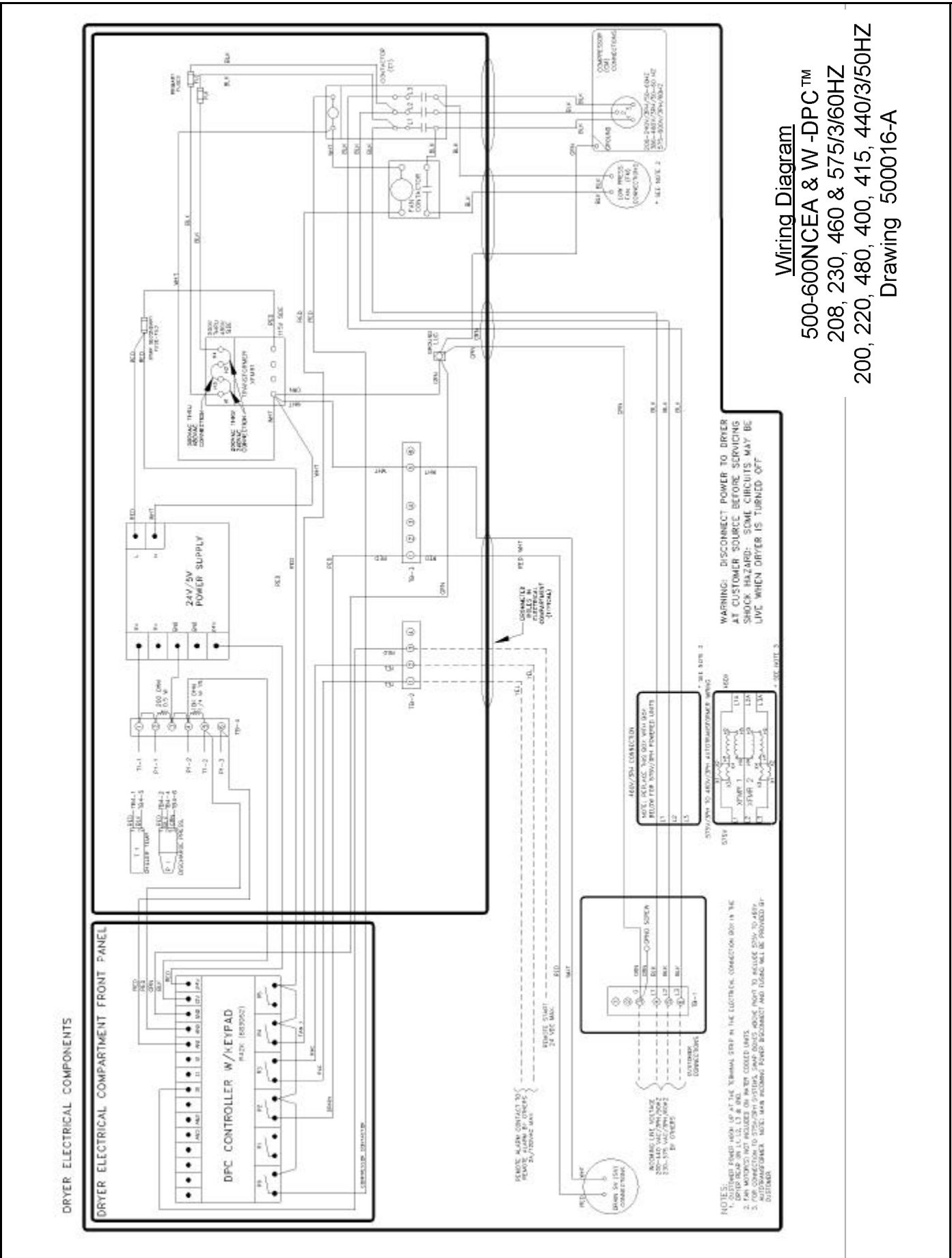

DRYER ELECTRICAL COMPONENTS

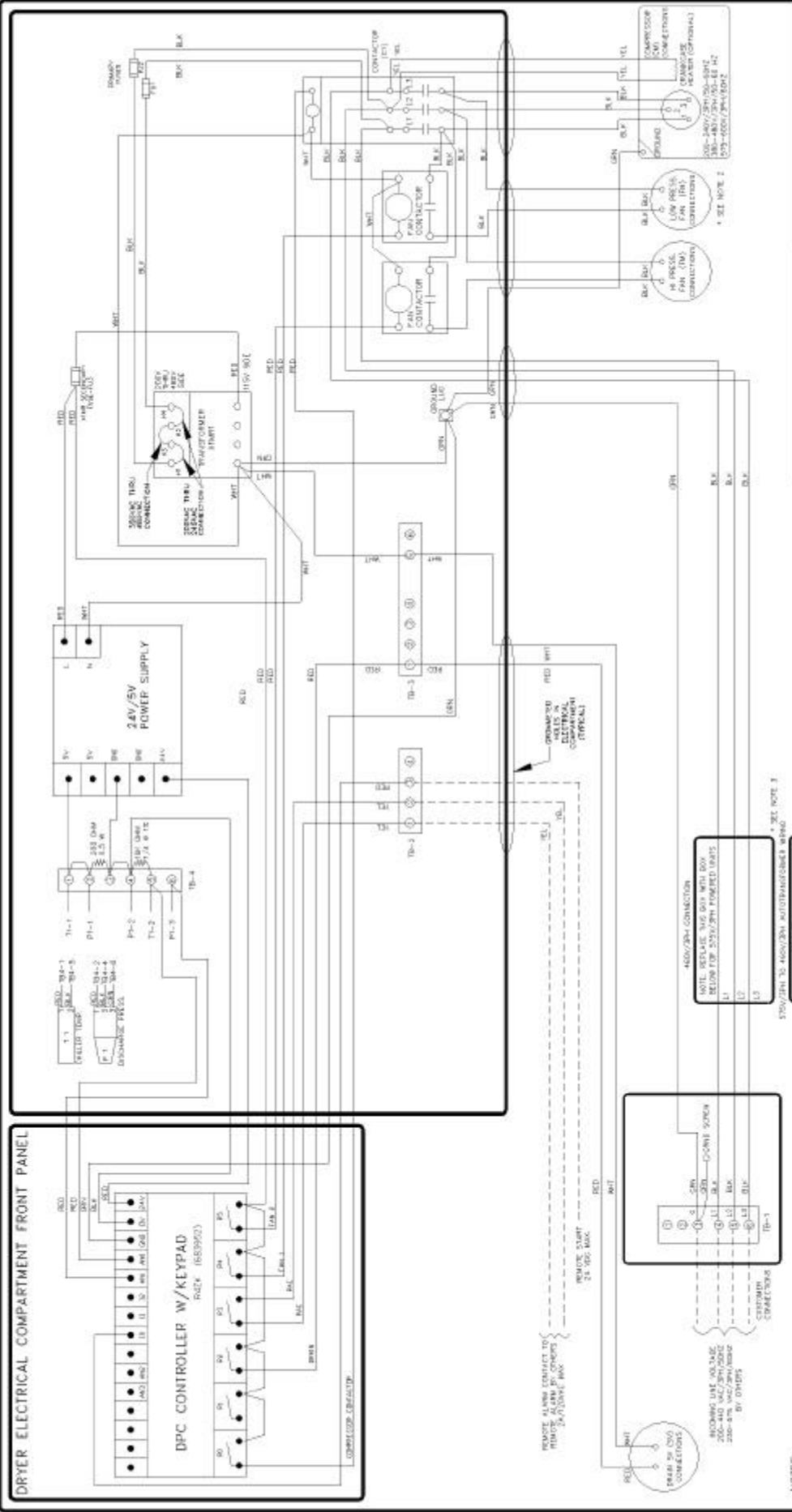

WARNING: DISCONNECT POWER TO DRYER AT CUSTOMER SOURCE BEFORE SERVICING. SHOCK HAZARD: SOME CIRCUITS MAY BE LIVE WHEN DRYER IS TURNED OFF.

Wiring Diagram
700-800NCEA & W - DPC™
208, 230, 460 & 575/3/60HZ
200, 220, 480, 400, 415, 440/3/50HZ
Drawing 500014-A

NOTES:
 1. CUSTOMER POWER WIRE UP AT THE TERMINAL STRIP IN THE ELECTRICAL COMPARTMENT BOX IN THE DRYER REAR ON L1, L2, L3 & GND.
 2. FAN MOTOR(S) NOT INCLUDED ON BASIC COOLER UNIT.
 3. WIRING FOR 200V/200V/200V/3/60HZ CUSTOMER POWER SOURCE MUST INCLUDE 200V TO 400V AUTOTRANSFORMER. 200V MAIN PROTECT FUSED DISCONNECT AND FUSED WIRE BE PROVIDED BY CUSTOMER.
 4. SEE NOTE 3.
 5. SEE NOTE 3.

DRYER ELECTRICAL COMPONENTS

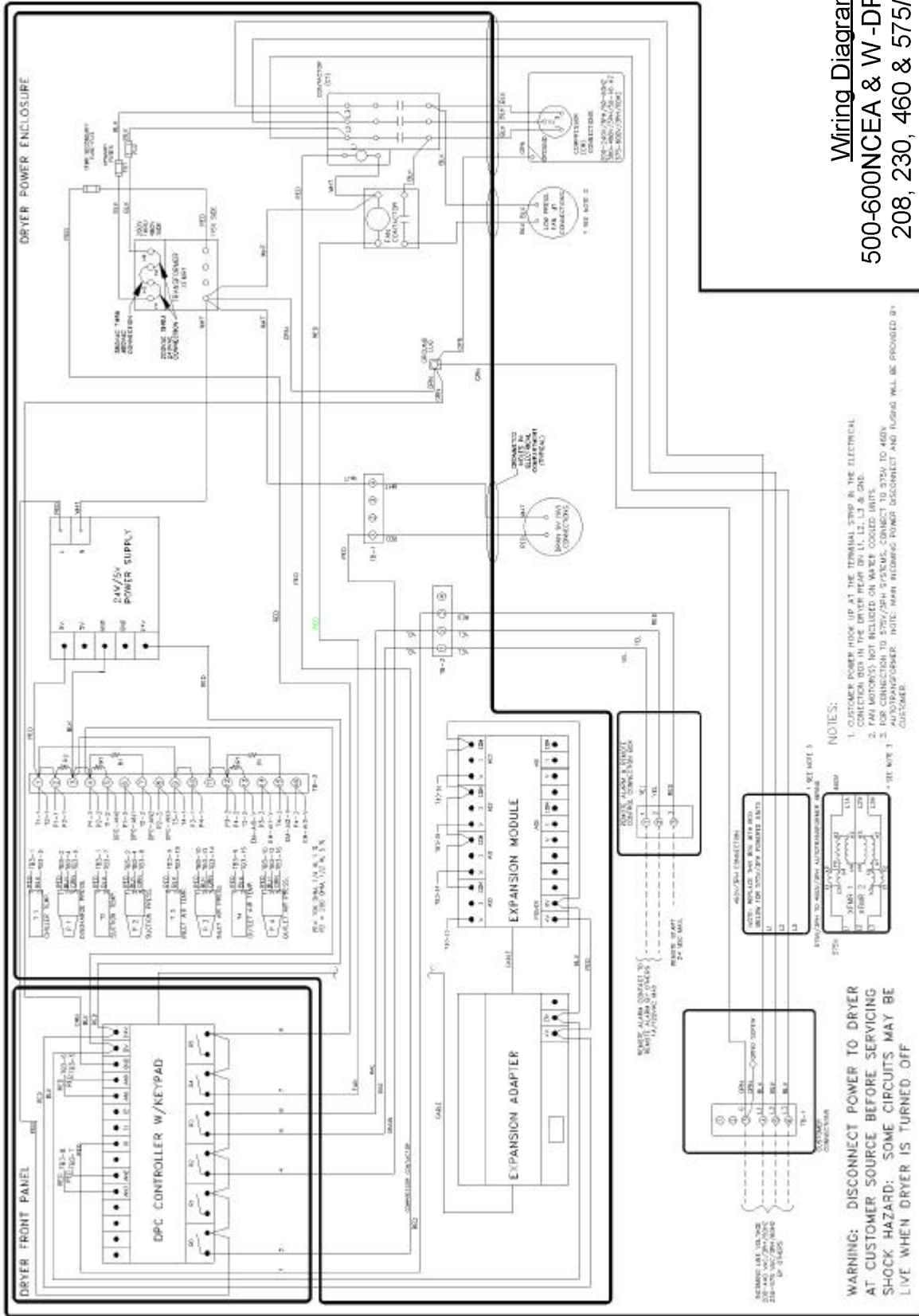

Wiring Diagram
500-600NCEA & W-DPC™ Plus
 208, 230, 460 & 575/3/60HZ
 200, 220, 480, 415, 440/3/50HZ
 Drawing 500184

DRYER ELECTRICAL COMPONENTS

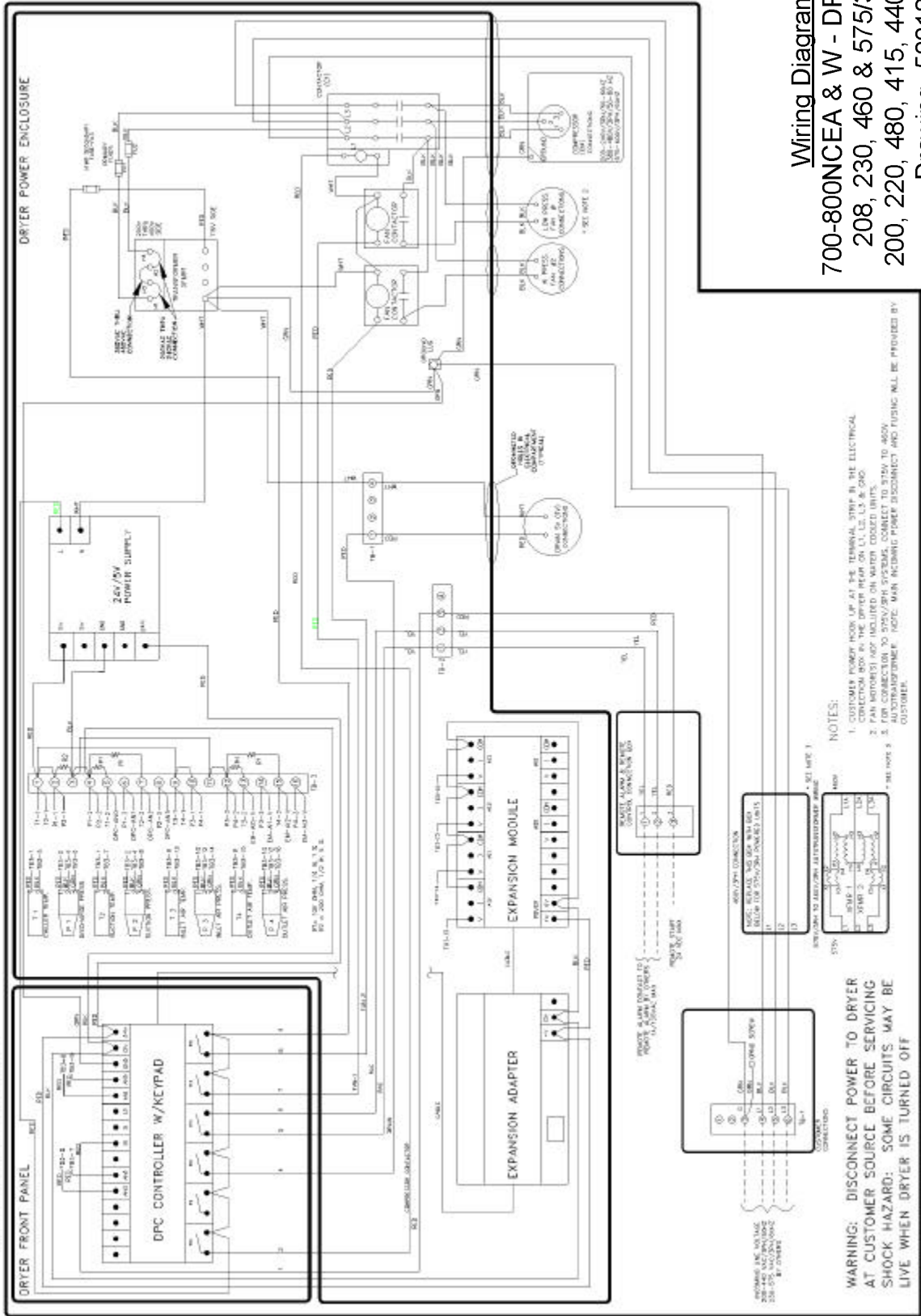

Wiring Diagram
700-800NCEA & W - DPC™ Plus
 208, 230, 460 & 575/3/60HZ
 200, 220, 480, 415, 440/3/50HZ
 Drawing 500182

- NOTES:**
1. CUSTOMER POWER RUN UP AT THE TERMINAL STRIP IN THE ELECTRICAL CONNECTION BOX IN THE DRYER REAR OR ON L.L. U.L. L.S. & O.R.D.
 2. FAN MOTOR IS NOT INSTALLED ON VARIOUS COOLED UNITS.
 3. FAN MOTOR IS NOT INSTALLED ON VARIOUS COOLED UNITS.
 4. CUSTOMER POWER DISCONNECT AND FUSING WILL BE PROVIDED BY CUSTOMER.

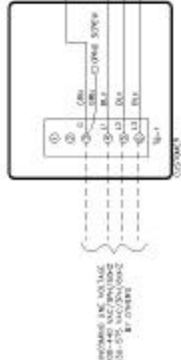

WARNING: DISCONNECT POWER TO DRYER AT CUSTOMER SOURCE BEFORE SERVICING. SHOCK HAZARD: SOME CIRCUITS MAY BE LIVE WHEN DRYER IS TURNED OFF.

12. GENERAL ARRANGEMENT

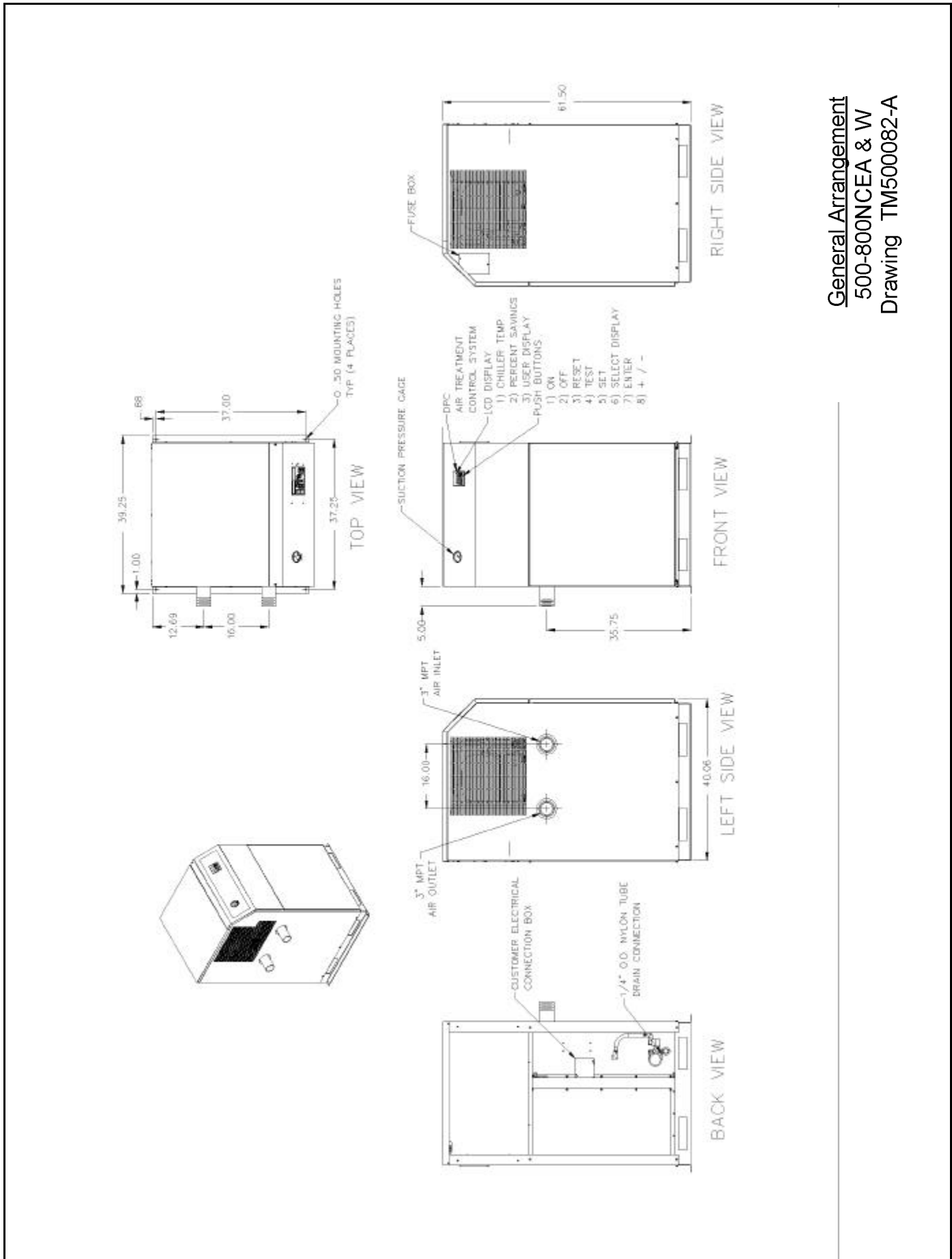

General Arrangement
500-800NCEA & W
Drawing TM500082-A

13. PARTS IDENTIFICATION

		500 NCE	600 NCE	700 NCE	800 NCE
1	Exchanger Assy	748065	748069	748056	748056
2	Solenoid Drain Valve	682657	682657	682657	682657
3	Drain Valve Repair Kit	683006	683006	683006	683006
4	Filter Stop	682438	682438	682438	682438

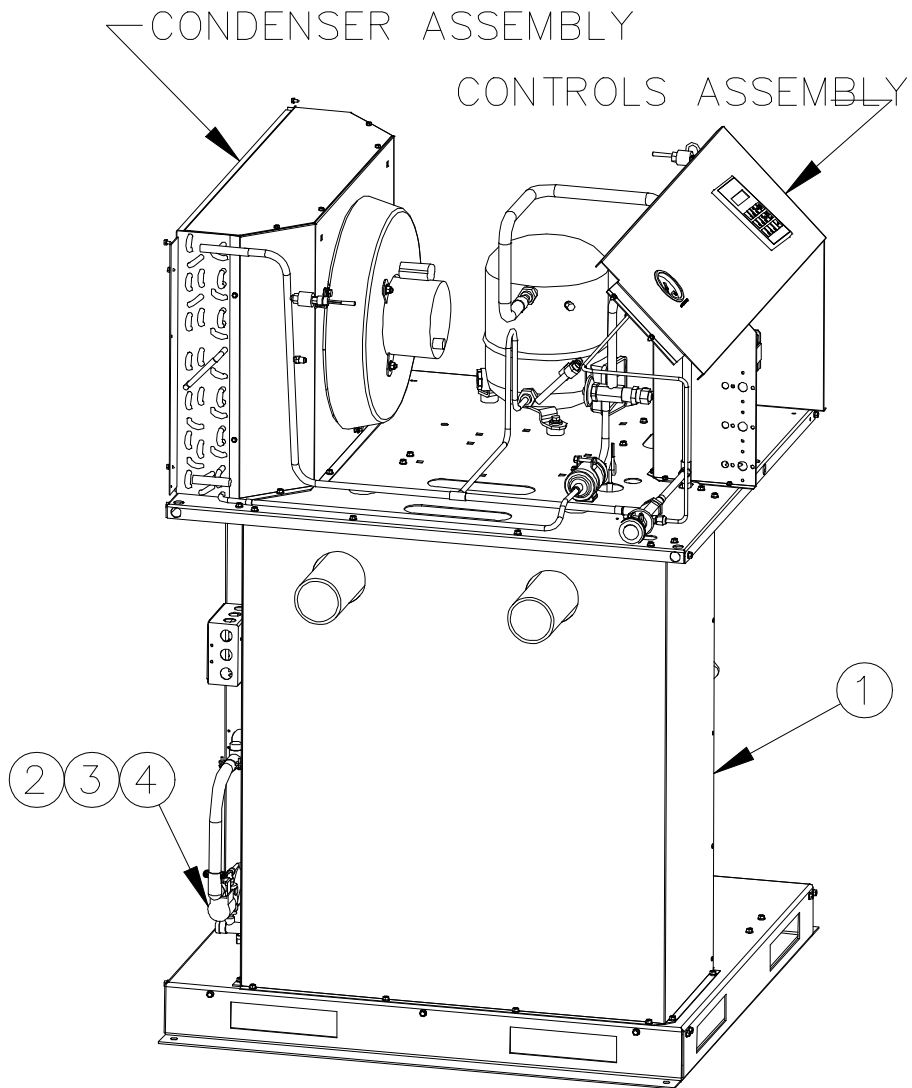

**PARTS OVERVIEW
TM500NCEA4000**

	500 NCE				600 NCE				700 NCE				800 NCE			
	460/3/60	380/3/50	230/3/60	220/3/50	460/3/60	380/3/50	230/3/60	220/3/50	460/3/60	380/3/50	230/3/60	220/3/50	460/3/60	380/3/50	230/3/60	220/3/50
1 Compressor	682562	682564	682606	682567	682564	682569	682570	682600	682569	682572	682568	682573	682572	682575	682571	682576
2 Condenser	683100	683100	683100	683100	683100	683100	683100	683100	683100	683100	683100	683100	683100	683100	683100	683100
3 Fan Motor	681802	681802	681803	681803	681802	681802	681803	681803	681802	681802	681803	681803	681802	681802	681803	681803
4 Fan Blade	696156	696156	696156	696156	696156	696156	696156	696156	696156	696156	696156	696156	696156	696156	696156	696156
5 Fan Guard	682569	682569	682569	682569	682569	682569	682569	682569	682569	682569	682569	682569	682569	682569	682569	682569
6 Filter Dryer	600386	600386	600386	600386	600386	600386	600386	600386	600386	600386	600386	600386	600386	600386	600386	600386
7 Expansion Valve	683083	683083	683083	683083	683083	683083	683083	683083	683083	683083	683083	683083	683083	683083	683083	683083
8 Filter, Ambient Air	682961	682961	682961	682961	682961	682961	682961	682961	682961	682961	682961	682961	682961	682961	682961	682961
9 Hot Gas Bypass Valve	686133	686133	686133	686133	686133	686133	686133	686133	686133	686133	686133	686133	686133	686133	686133	686133

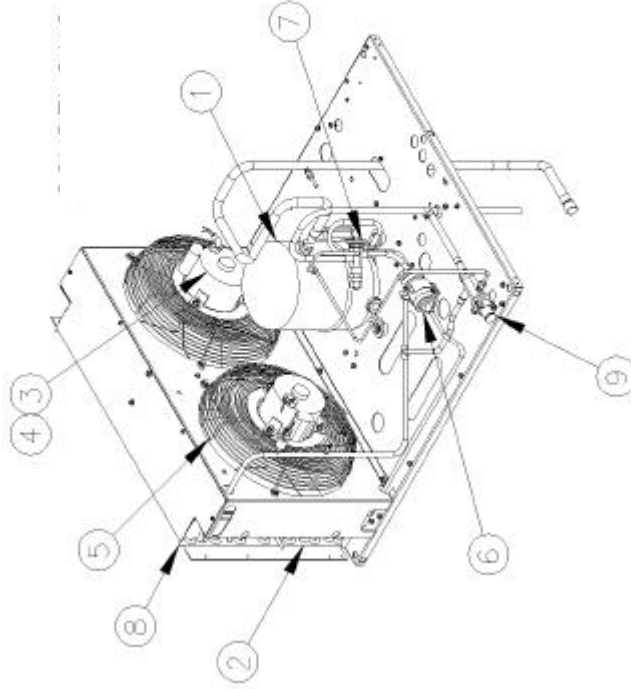

CONDENSING ASSEMBLY
700-800NCE
TM748071

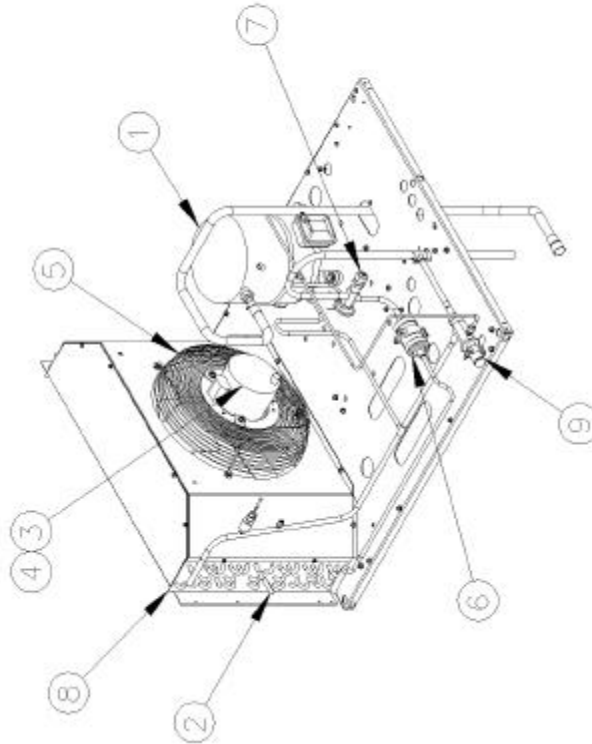

CONDENSING ASSEMBLY
500-600NCE
TM748073

	500 & 600 NCE			700 & 800 NCE		
	460/3/60	575/3/60	230/3/60	460/3/60	575/3/60	230/3/60
1 Control Transformer	681861	681861	681861	681861	681861	681861
2 Primary Control Fuse	699807	699807	699392	699807	699807	699392
3 Secondary Control Fuse	698739	698739	698739	698739	698739	698739
4 Power Supply Fuse	683976	683976	683976	683976	683976	683976
5 Ext. Fuseholder (13/32")	699406	699408	699408	699408	699408	699408
6 Ext. Fuseholder (1/4")	682552	682552	682552	682552	682552	682552
7 Contactor (3-Pole)	697290	697290	697290	697290	697290	697290
8 Contactor (1-Pole)	699621	699621	699621	699621	699621	699621
9 Gauge (Suction)	682603	682603	682603	682603	682603	682603
10 Power Supply	683956	683956	683956	683956	683956	683956
11 Digital Controller DPC-2	800087	800087	800087	800087	800087	800087
12 Digital Controller Battery	683975	683975	683975	683975	683975	683975
13 Temperature Probe	682955	682955	682955	682955	682955	682955
14 Pressure Transducer, Discharge, 0-500 PSI	682943	682943	682943	682943	682943	682943
15 Pressure Transducer, Inlet/Outlet Air & Suction, 0-300 PSI (DPC-8 only)	682942	682942	682942	682942	682942	682942
16 Transducer Cable, Refrig. Discharge & Suction - 5 ft.	682945	682945	682945	682945	682945	682945
17 Transducer Cable, Inlet & Outlet Air - 10 ft. (DPC-8 only)	682946	682946	682946	682946	682946	682946

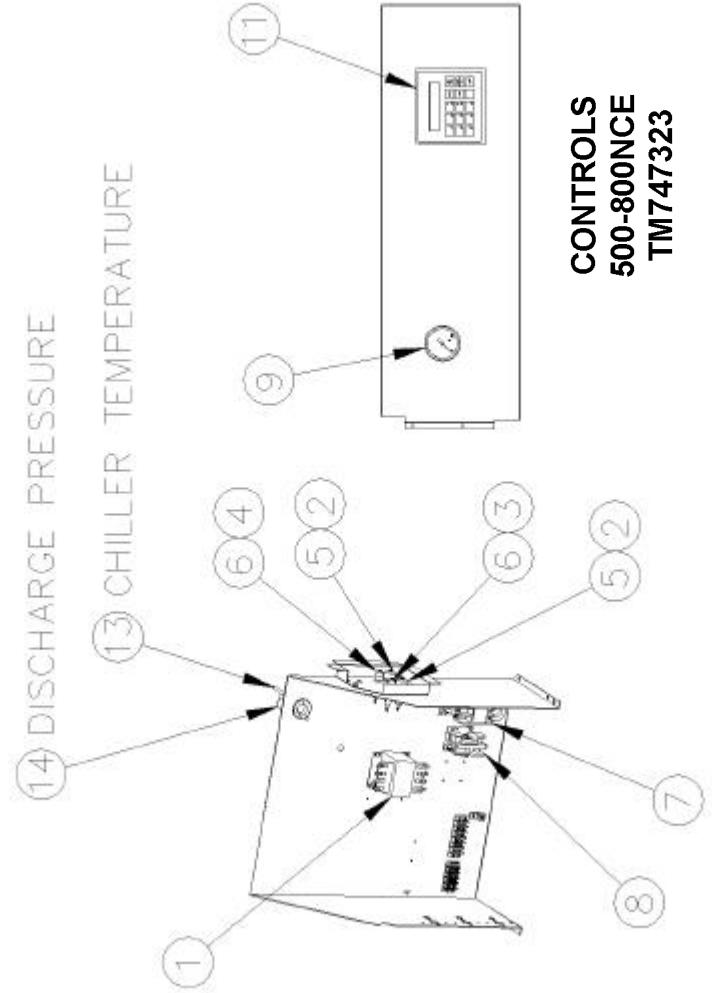

**CONTROLS
500-800NCE
TM747323**

14. ENGINEERING SPECIFICATIONS

MODEL NO.		VOLTS/PH/Hz		AIR COOLED CONDENSERS																	
				COMPRESSOR RATINGS				FAN RATINGS				REFRIGERANT				MAX. FUSE		MIN. CIRCUIT		WEIGHT	
				HP	RLA	LRA	QTY	HP	RLA	LRA	HP	LB-OZ	TYPE	LB-OZ	SIZE	AMPACITY	LBS.	KG.			
500NCE	460/3/60	420/380/3/50	2.50	7.5	23.0	1	1/4	0.80	1.2	R-404	7-8	15	10.3	950	432.0						
	230/3/60	240/200/3/50	2.50	16.0	57.0	1	1/4	0.80	1.2	R-404	7-8	35	21.1	950	432.0						
	575/3/60	500/480/3/50	2.50	7.5	23.0	1	1/4	0.80	1.2	R-404	7-8	12	8.3	950	432.0						
600NCE	460/3/60	420/380/3/50	3	9.0	30.0	1	1/4	0.80	1.2	R-404	8-0	20	12.2	950	432.0						
	230/3/60	240/200/3/50	3	17.0	74.0	1	1/4	0.80	1.2	R-404	8-0	35	22.4	950	432.0						
	575/3/60	500/480/3/50	3	9.0	30.0	1	1/4	0.80	1.2	R-404	8-0	15	9.8	950	432.0						
700NCE	460/3/60	420/380/3/50	3.5	10.0	38.0	2	1/4	0.80	1.2	R-404	6-8	20	14.3	1050	477.0						
	230/3/60	240/200/3/50	3.5	22.0	98.0	2	1/4	0.80	1.2	R-404	6-8	50	29.4	1050	477.0						
	575/3/60	500/480/3/50	3.5	10.0	38.0	2	1/4	0.80	1.2	R-404	6-8	15	11.4	1050	477.0						
800NCE	460/3/60	420/380/3/50	4	10.0	47.0	2	1/4	0.80	1.2	R-404	8-0	20	14.3	1050	477.0						
	230/3/60	240/200/3/50	4	22.0	100.0	2	1/4	0.80	1.2	R-404	8-0	50	29.4	1050	477.0						
	575/3/60	500/480/3/50	4	10.0	47.0	2	1/4	0.80	1.2	R-404	8-0	15	11.4	1050	477.0						

NOTE: Electrical ratings based on 60-Hz dryers

NOTE: MAXIMUM WORKING PRESSURE 300 PSIG

Specification information above accurate at time of publication. Refer to equipment serial label for actual refrigerant charges and specifications for units.