

Installation instructions:



AKRAPOVIC SLIP-ON & SLIP-ON MEGAPHONE EXHAUST SYSTEM for the YAMAHA YZF R6 (2008)

Congratulations on purchasing an Akrapovic exhaust system. Please read these installation instructions carefully. If you have any trouble installing the system please contact your authorized dealer!

IMPORTANT INFORMATION

Exclusion of Certain Liability

1. The manufacturer, importer or dealer shall not be liable for any incidental damage including personal injury or any other damages caused by improper installation or operation of the Akrapovic exhaust system. When installing the Akrapovic exhaust system be careful that the exhaust system does not touch other parts sensitive to high temperature.
2. Akrapovic makes no representation or warranties with regard to damage caused by the improper installation, use and maintenance of the Akrapovic exhaust system. The warranty is limited to defects recognized by our technical department and to normal use, and excludes items subject to normal wear (gaskets and damping wool). The guarantee is void in case of accident, modification, improper or competition use.
3. Do not attempt to install the Akrapovic exhaust system on a motorcycle for which it was not made or tested by Akrapovic.
4. When the exhaust system gets very hot during operation, be careful not to burn yourself on the exhaust system or parts which are in direct contact with it, even when the motor is not running. Also protect other people, especially children, from the injuries mentioned above.
5. In some cases Akrapovic exhaust system kits contain chemical products (ceramic anti-seizing grease; bolt sealant). Handle with care, do not inhale or swallow. Avoid excessive contact with skin, eyes or mucous membranes. Keep out of reach of children.
6. Technical specifications of Akrapovic exhaust systems and related products subject to change without notice.

Trademarks

The Akrapovic Exhaust System Technology logo is a registered trademark of Akrapovic d.d.

Akrapovic website

Information about Akrapovic exhaust systems and related products is available on the Akrapovic website at:
<http://www.akrapovic-exhaust.net/>

Copyright

No part of the Akrapovic exhaust system or its documentation may be reproduced or distributed in any form or by any means without the prior written authorization of the Akrapovic company.

© Akrapovic, d.d. All rights reserved.

Symbols

The following symbols are used throughout these installation instructions:



USE BOLT SEALANT; Apply 3 to 4 small drops of bolt sealant onto the cleaned and degreased threads before tightening bolts. **WARNING! Avoid contact with skin, eyes and mucous membranes. Do not inhale fumes. Keep out of the reach of children.**



USE ANTI-SEIZING GREASE (white tube); Prevents seizing, corrosion and excessive wear between the titanium components of your exhaust system. **WARNING! Avoid eye contact. Avoid excessive skin contact. Keep out of the reach of children.**



USE ANTI-SEIZE LEAD-FREE COPPER PASTE (black tube); Provides trouble-free and long-lasting protection against seizing, corrosion and rusting of bolts, threaded ends, nuts, joints, etc. Also protects against vibration, wear and impact. **WARNING! Avoid eye contact. Avoid excessive skin contact. Keep out of the reach of children.**

INSTALLATION INSTRUCTIONS

 **BEFORE INSTALLING CHECK SCHEMATIC OF THE EXHAUST SYSTEM!**

! IF ANY ITEMS IN THE AKRAPOVIC EXHAUST SYSTEM PACKAGE ARE MISSING PLEASE CONTACT YOUR AUTHORIZED DEALER. KEEP THE SCHEMATIC FOR FUTURE REFERENCE.

! THESE INSTALLATION INSTRUCTIONS MUST BE READ CAREFULLY IN ORDER TO ENSURE PROPER INSTALLATION AND OPERATION OF THE AKRAPOVIC EXHAUST SYSTEM.

! THE EXHAUST SYSTEM CAN BE EXTREMELY HOT. ALLOW THE MOTORCYCLE TO COOL DOWN BEFORE BEGINNING INSTALLATION.

 **WE ADVISE YOU TO LEAVE INSTALLATION TO A QUALIFIED SERVICEMAN. IMPROPER INSTALLATION MAY RESULT IN A SHORTER LIFETIME OF THE EXHAUST SYSTEM AND/OR DAMAGE TO THE MOTORCYCLE.**



T-handle 8mm wrench
T-handle 10mm swiveling wrench
T-handle 12mm wrench
T-handle 4mm three hexagon key wrench
T-handle 5mm three hexagon key wrench
Combination 10mm wrench
Spring puller
T-handle 13mm wrench

REMOVAL OF STOCK EXHAUST SYSTEM:

1. Put the motorcycle on a side stand, we recommend a racing stand. Make sure, that surface is solid and flat.
2. Unscrew the bolt from the muffler chassis hanging bracket (**Figure 1**).



Figure 1

3. Unscrew the bolt from the exhaust valve heat shield and remove the shield (**Figure 2, 3**).



Figure 2



Figure 3

4. Loosen and completely remove the cables from the exhaust valve (**Figure 4, 5**).



Figure 4



Figure 5

5. Unscrew the bolt and remove the harness of the exhaust valve cables (**Figure 6**). Unscrew the bolts from the servo motor chassis hanging bracket (**Figure 7**).



Figure 6



Figure 7

6. Slightly remove the servo motor (**Figure 8**). **WARNING: Do not turn the servo motor wheel with force or the servo motor could be damaged.** Completely remove the exhaust valve cables from the servo motor (from the control wheel for cable position) and from the frame (**Figure 9**).



Figure 8



Figure 9

7. Reinstall the servo motor on its place on the motorcycle using stock bolts (Figure 10, 11). **WARNING! Do not disconnect the electrical installation of the servo motor!**



Figure 10

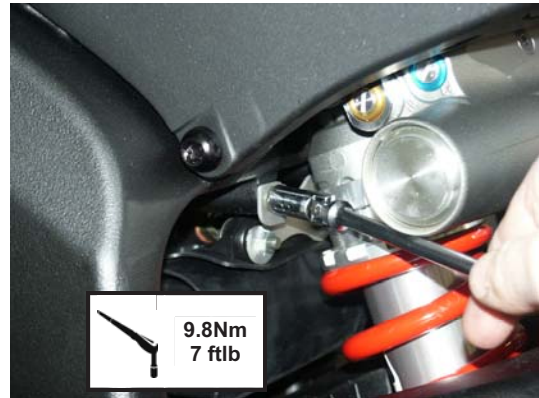

Figure 11

8. Unscrew the bolt from the metal clamp at the muffler - link pipe joint, remove the muffler, the gasket and flange (Figure 12, 13, 14, 15).



Figure 12



Figure 13



Figure 14



Figure 15

INSTALLATION OF THE AKRAPOVIC SLIP-ON EXHAUST SYSTEM

1. Transposition the metal collar from the muffler bracket (**Figure 16, 17**).



Figure 16



Figure 17

2. Install the Akrapovic metal clamp onto the Akrapovic muffler (**Figure 18**). Correctly position the carbon-fiber clamp and slide it onto the muffler - bear in mind **the left offset** of the carbon-fiber clamp viewed from the rear (**Figure 19**).
WARNING: open the clamp to slightly wider than the diameter of the outer sleeve of the muffler – do not scrape it along the muffler outer sleeve!



Figure 18



Figure 19

3. Position the muffler correctly and slide it onto the outlet side of the stock link pipe (**Figure 20**). Attach the spring onto the stock collector bracket (check figure!) and muffler (**Figure 21**).



Figure 20



Figure 21

4. Tighten the carbon-fiber clamp onto the stock chassis hanging bracket on the frame (Figure 22, 23). Make sure the muffler is not touching other parts of the motorcycle. Tighten fully the metal clamp at the muffler – stock link pipe joint (Figure 24).



Figure 22

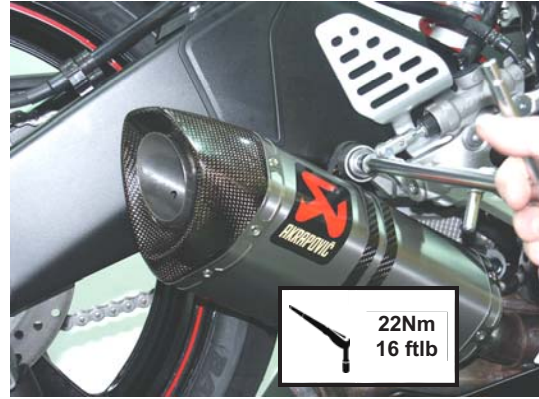

Figure 23

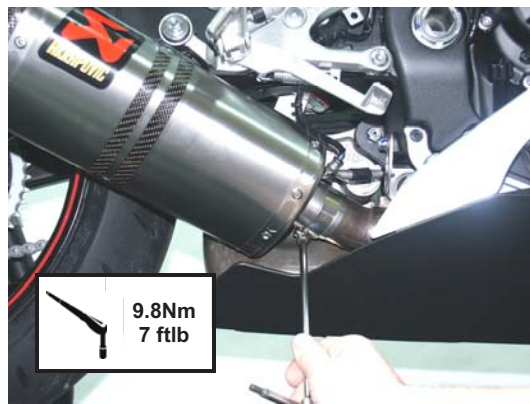

Figure 24

INSTALLATION OF THE AKRAPOVIC SLIP-ON MEGAPHONE EXHAUST SYSTEM

1. Install the Akrapovic metal clamp onto the Akrapovic megaphone inlet bush (Figure 25). Position the megaphone tube correctly and slide it onto the outlet side of the stock link pipe (Figure 26).

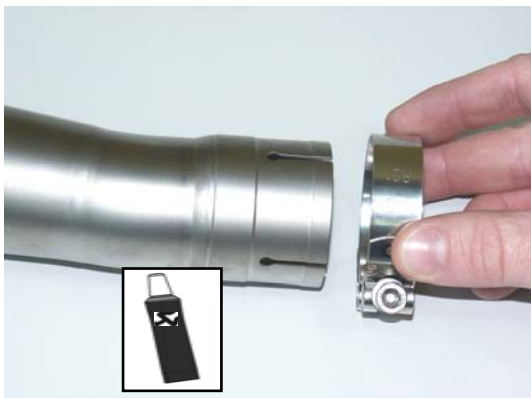

Figure 25



Figure 26

2. Tighten fully the bolt of the megaphone tube hanging bracket onto the stock chassis hanging bracket (**Figure 27, 28**). Make sure the megaphone tube is not touching other parts of the motorcycle. Tighten fully the metal clamp at the megaphone – stock link pipe joint (**Figure 29**).



Figure 27

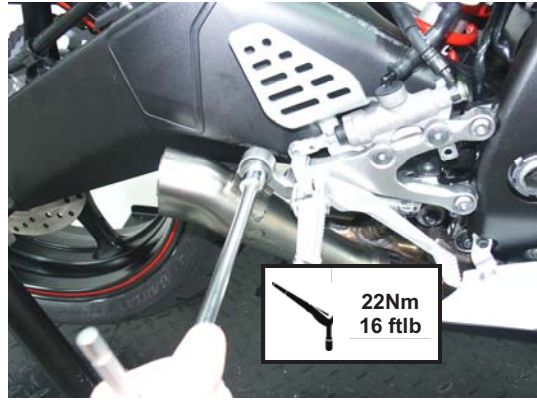

Figure 28

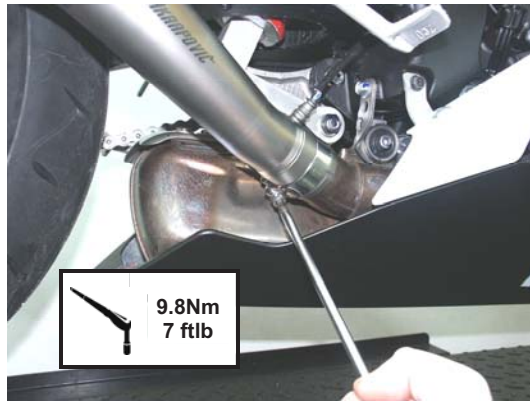

Figure 29

Final installation:

1. Clean grease spots:
 - a. Muffler – carbon-fiber outer sleeve: use a soft dry cloth.
 - b. Muffler – titanium outer sleeve: use a soft cloth sprayed with a multi-purpose spray lubricant (WD-40 or equivalent).
 - c. Muffler – carbon-fiber outlet cap: use a soft dry cloth.
 - d. Stainless steel inlet bush and rosette: use a soft cloth sprayed with a contact cleaner, then wipe with a soft dry cloth.
 - e. Titanium Megaphone: use a soft cloth sprayed with a multi-purpose spray lubricant (WD-40 or equivalent).Cleaning will prevent spots from burning onto the surface. Do not use aggressive chemical cleaners, because they can damage the sticker.

Position of the installed Akrapovic Slip-On or Megaphone version system (Figure 30, 31).



Figure 30



Figure 31

2. Check the operation of the brakes and suspension. Make sure all the bolts are sufficiently tightened. In case the exhaust system touches the cowling or other parts repeat the adjustment of the exhaust system or contact your authorized dealer.

! IT IS NORMAL IF WHITE SMOKE COMES OUT OF THE MUFFLER ON FIRST OPERATION.

! DO NOT STAND BEHIND THE MUFFLER ON FIRST OPERATION.

! DO NOT USE AUTOMOTIVE WHEEL CLEANERS OR ANY CLEANING PRODUCTS WHICH CONTAIN ACIDIC ADDITIVES TO CLEAN AKRAPOVIC EXHAUST SYSTEMS.

MAINTENANCE OF THE AKRAPOVIC EXHAUST SYSTEM

1. Clean the titanium exhaust components with a multi-purpose spray lubricant (WD-40 or equivalent), carbon fiber exhaust components with soft and dry cloth and stainless steel components with soft cloth sprayed with contact cleaner, then wipe with soft and dry cloth. Do not use aggressive chemical cleaners, because they can damage the sticker. A change in the color of the exhaust system is normal due to the high temperatures.
2. The wearing out of the muffler silencing material depends on the type of the engine and riding style. Contact your dealer/serviceman if visible changes appear on muffler's outer sleeve or the noise level is increased.
3. Periodically make sure all the bolts and springs are sufficiently tight.

YAMAHA R6 Slip on, OPEN/ Model year:2008
Product code: S-Y6SO7-ZC
S-Y6SO7-ZT

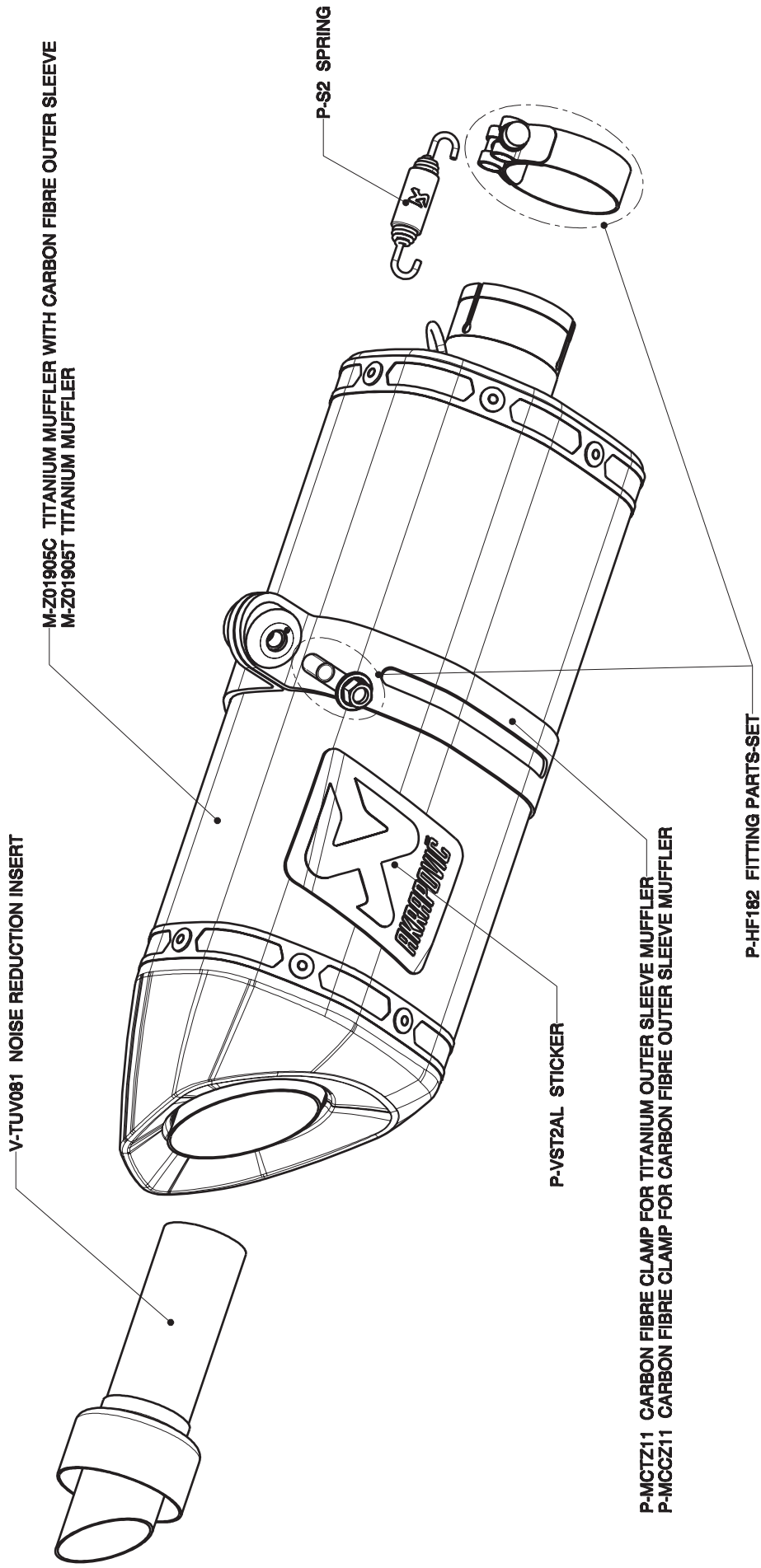

YAMAHA R6 Slip on, STREET LEGAL/ Model year:2008

Product code: S-Y6SO7-HZC
S-Y6SO7-HZT

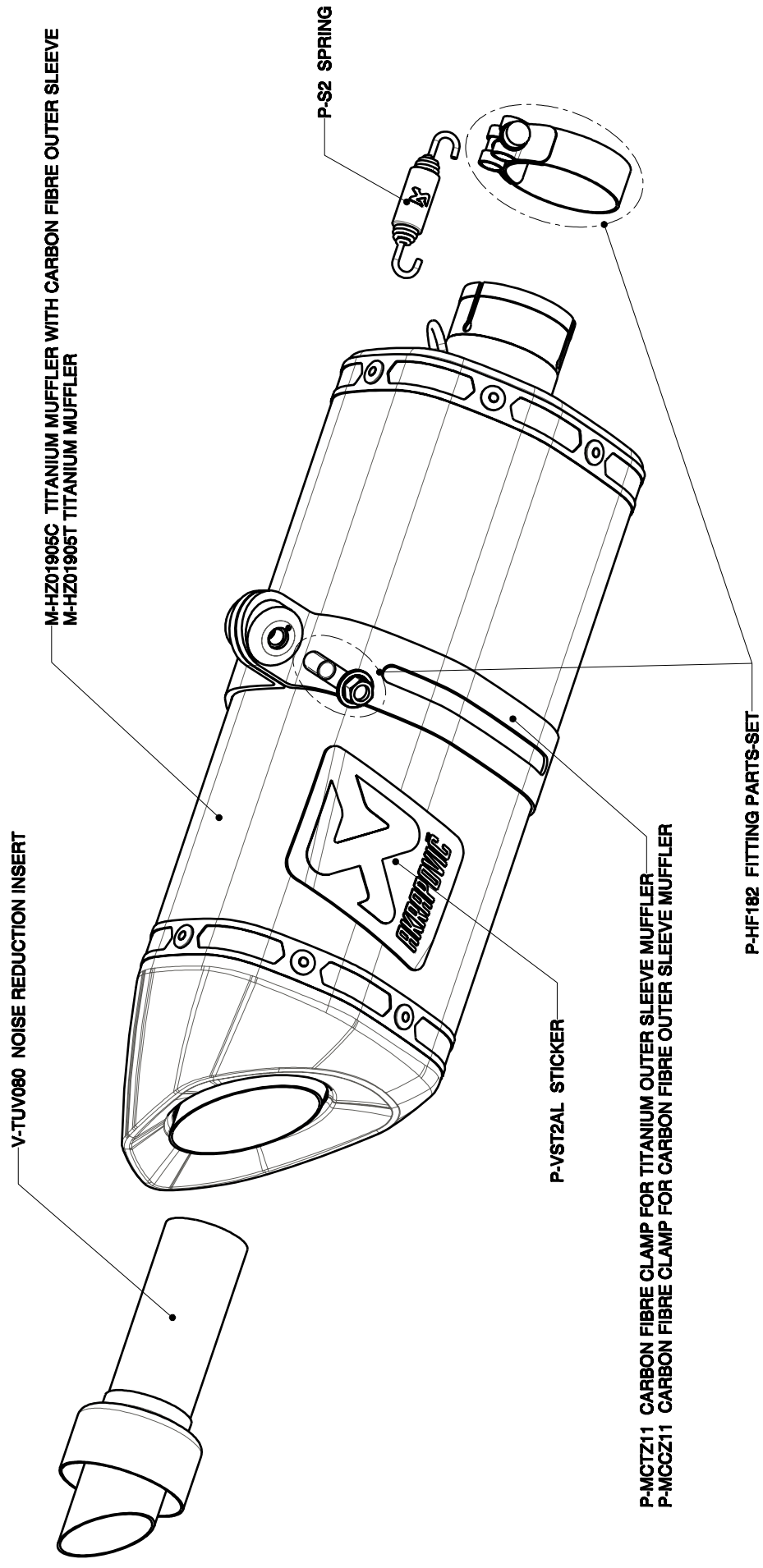

Yamaha YZF R6, Complete exhaust system / EVOLUTION LINE tube set with Street legal SLIP on Mufflers, Model year:2008
Product code: S-Y6RFT7TL-ZC/1
S-Y6RFT7TL-ZT/1

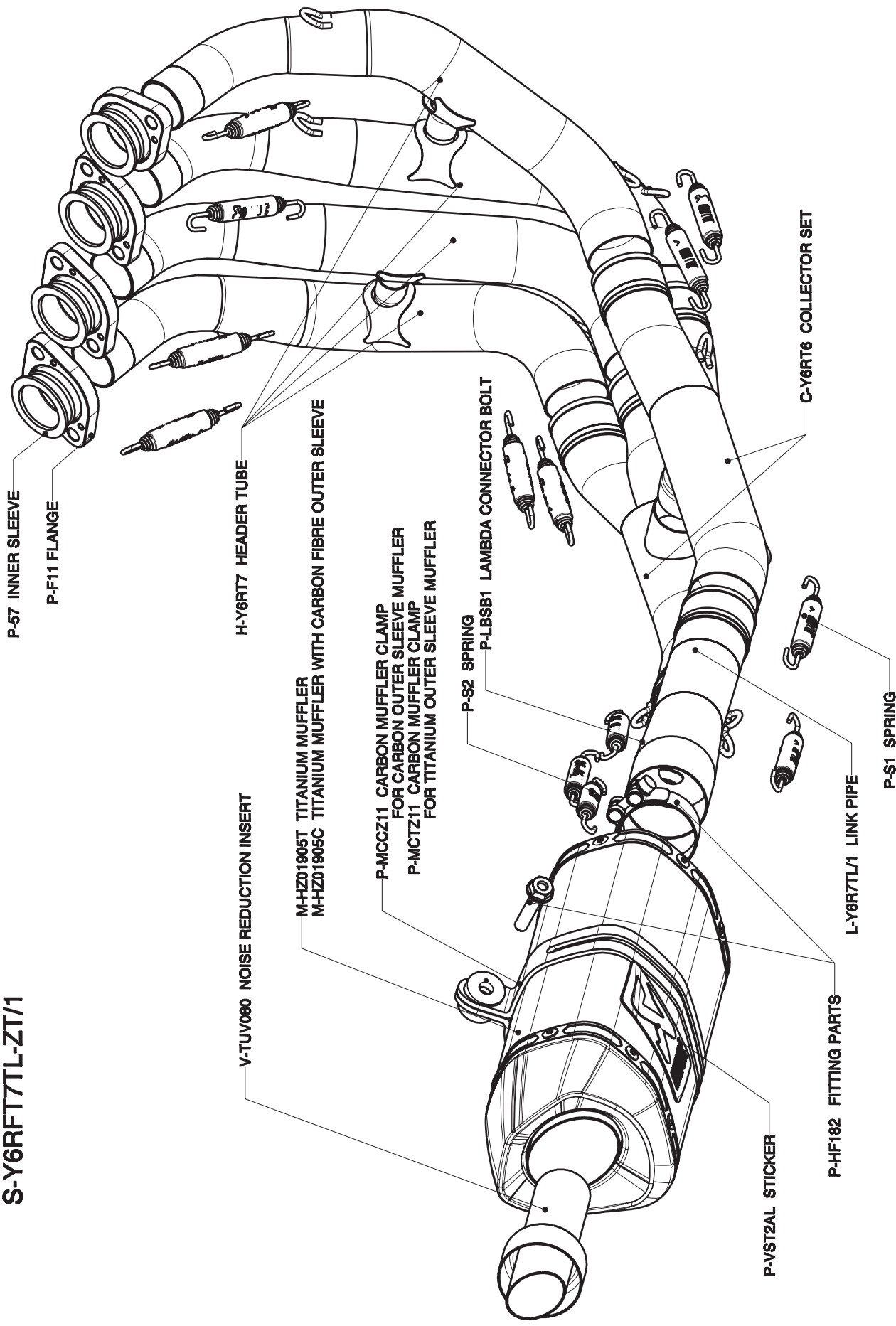

Yamaha YZF R6, Complete exhaust system / RACING LINE tube set with Street legal SLIP on Mufflers, Model year:2008
Product code: S-Y6R7-ZC/1
S-Y6R7-ZT/1

