

NEAR-VERTICAL INCIDENCE SKY-WAVE (NVIS) PROPAGATION

**The ideal Communications Mode
for Disaster and Emergency Situations**

**Presented by
Gerald Schuler
DU1GS / DL3KGS**

**PARA 82. Anniversary Meeting
November 30th 2014
Paranaque, Metro Manila**

HAM Radio in Disaster Communication

Requirement for Disaster Communication:

- Quick deployment and reliable Radio Connections needed

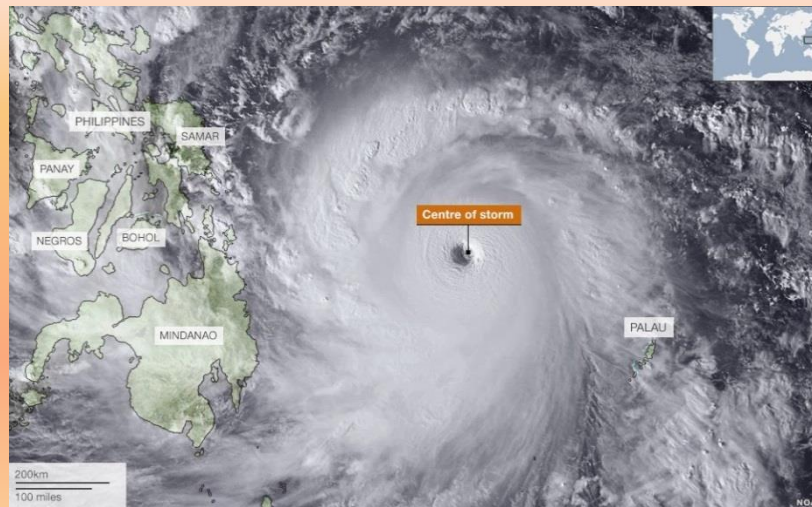

- With „Near Vertical Skyway Propagation“ this can be achieved

What is NVIS Propagation?

NVIS is a special form of ionospheric propagation

- NVIS covers the area which is normally in the skip zone
(Distance of the Ground wave and sky waves reflected from the ionosphere)
- To provide communications up to a range of 400 miles and more
- F2-Layer reflects the NVIS
- D-Layer is absorbing the Signals

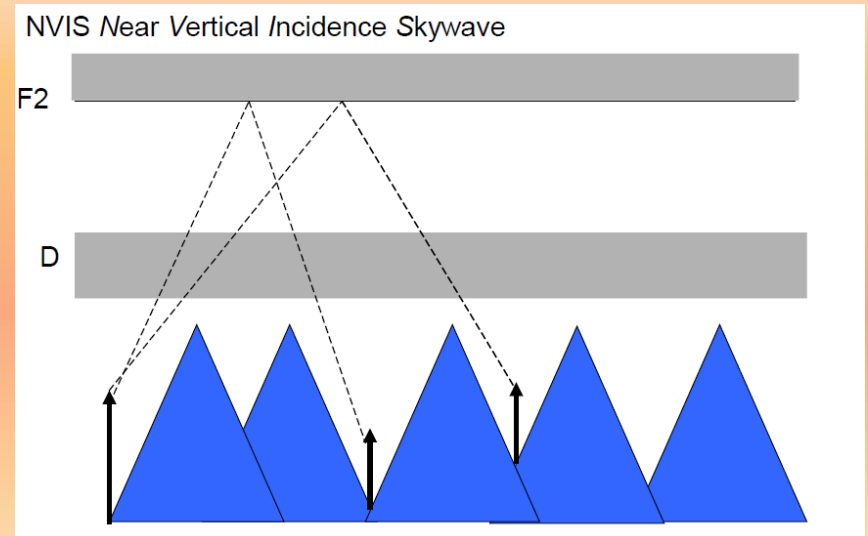

- NVIS Propagation is different to Long Range Communications (DX)

NVIS Propagation

- Radio signals “shoot” toward the cloud (F2-layer in the ionosphere) at a high elevation angle (> 50 - 90 degrees) and are reflected back
- Antenna height only 1/10th wavelength to 1/4 wavelength above ground. Then Antenna will radiate straight up to the sky due to the proximity to the ground
- Signals can be received within a nearly circular range around the transmitter
- Usable frequencies are in between 1.8 MHz and 10 MHz
- Antenna Polarization has to be Horizontal for NVIS, never Vertical !!!

NVIS (Local) verses Low Angle Signal Path (DX)

- Near Vertical Incidence Sky Wave (NVIS) propagation provides local and regional coverage at the lower HF bands ($f < 10\text{MHz}$)

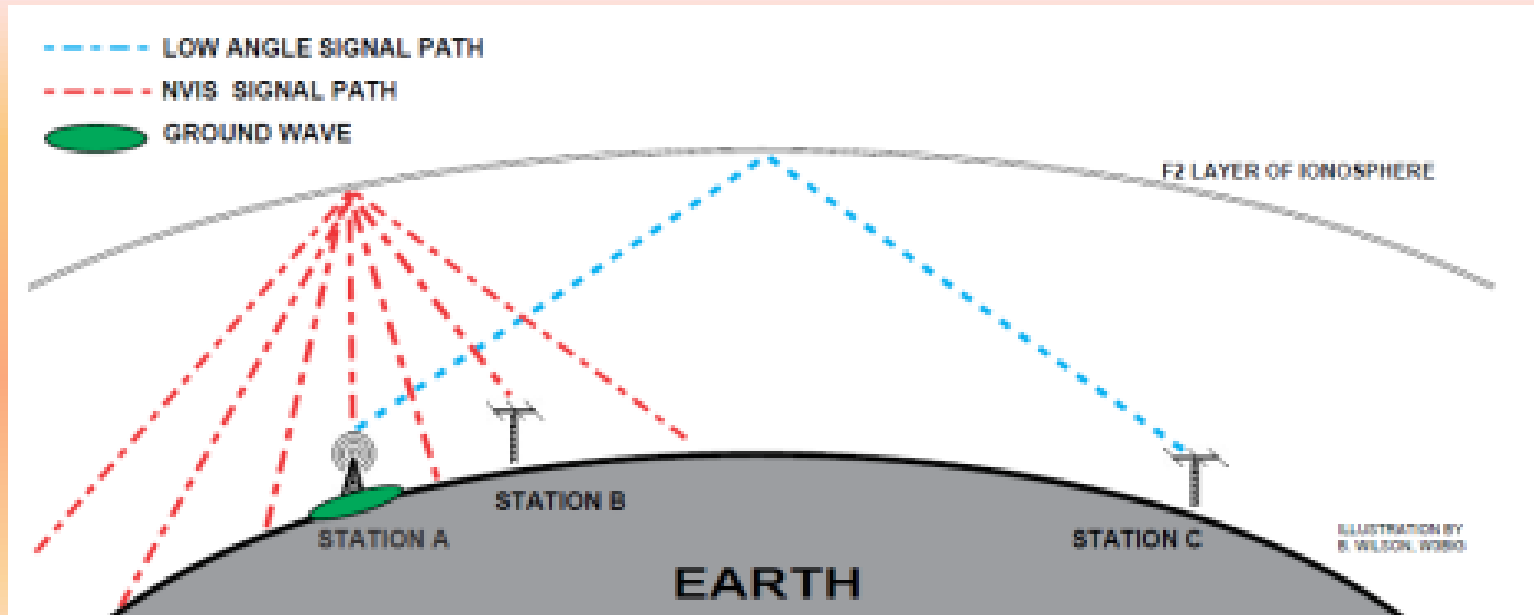

- Low Angle Signal Path provides Long-Range connections (DX, $f > 10\text{MHz}$)

Critical Frequency (CF) of F2-Layer

- NVIS Operation Frequency has to be below Critical Frequency (foF2)

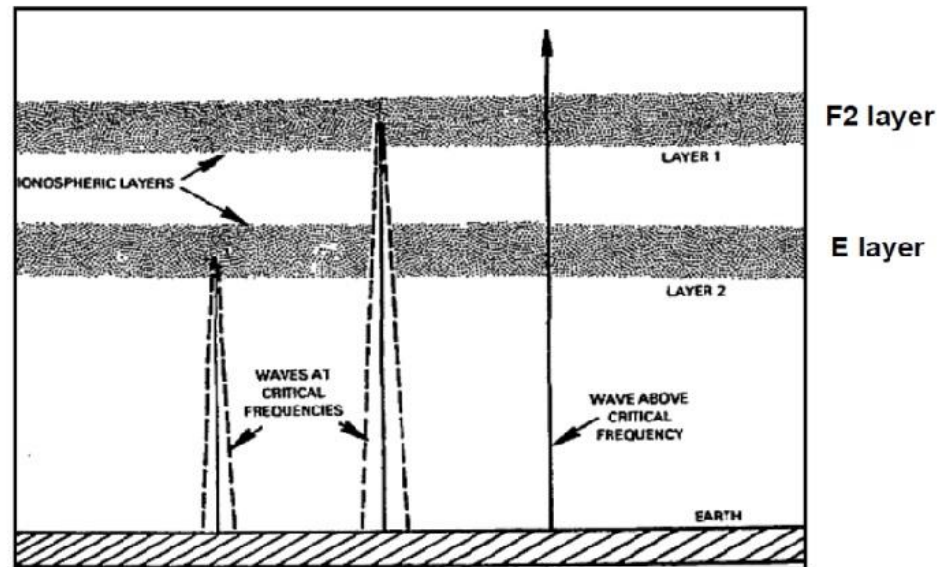

How NVIS works

- During **daytime**, the critical frequency (foF2) is approx. 5 to 10 MHz, increasing with the angle of the sun
- **After sunset**, the critical frequency (CF) drops throughout the night, reaching a low of 2 to 5 MHz -> minimum just before dawn
- **After sunrise**, the CF is rising constantly during day time, till noon
- Communications is getting more reliable due to reduced Noise and QRM (thunderstorms and DX) due to the high TOA (Take off angle)
- Ignore traditional advice for “installing antenna high” - **Get it LOW!**
- **All Stations in a regional Net should use NVIS-Antennas for best results**

Advantages of NVIS Concept

- “Skip-zone” free omnidirectional communications
- Terrain does not effect the loss of signal
- More constant receive signal level (RSL), less Fading over the operational range
- Orientation of Dipoles and Inverted-Vee Antennas are not critical
- No need for high Antenna tower or mast -> quick deployment
- Better Signal/Noise Ratio (SNR) -> only reduced TX-Power needed (25 Watts and less, -> longer battery live time during portable operation)
- Military Shortwave Manpack also use Power in the Range 20-30W

Antenna Diagrams - Height dependent

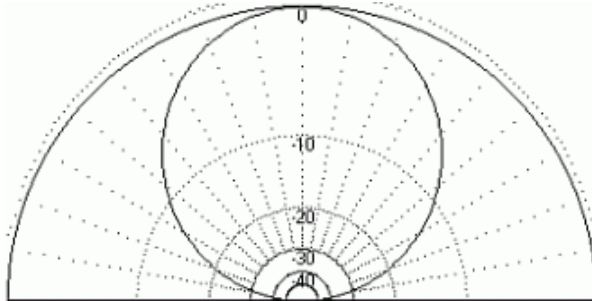

1a: 75-meter NVIS antenna at 20 feet high
The -10db ray is at about 38 degrees.
The -20db ray is at about 20 degrees.

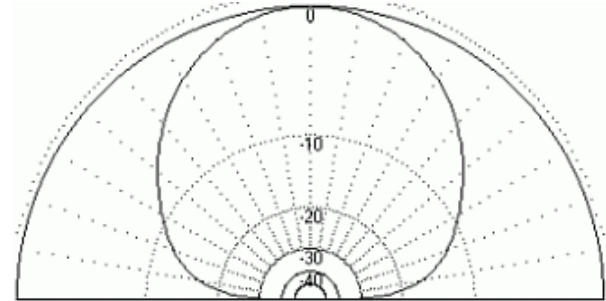

1b: 75-meter NVIS antenna at 67 feet high (quarter-wave).
The -10db ray is at about 28 degrees.
The -20db ray is at about 6 degrees.

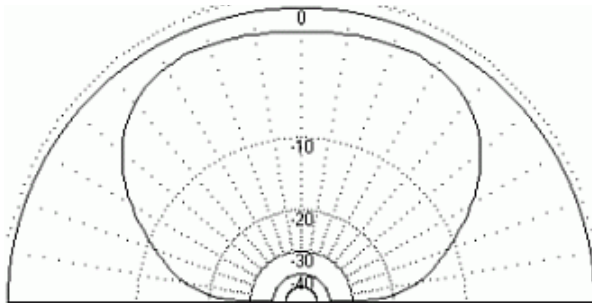

1c: 75-meter NVIS antenna at 90 feet high (3/8ths-wave). The -10db ray is at about 22 degrees, -20db at about 4 degrees, and considerably more power is now available at 30-60 degrees.

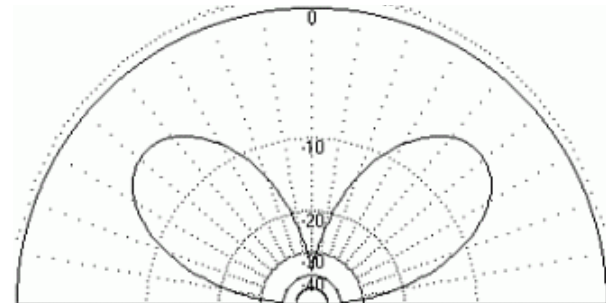

1d: 75-meter antenna at 125 feet high (half-wave)
No longer NVIS, but now a "skip" antenna,
with most of the power at about 42 degrees.

Simplified NVIS Link calculation

(Excel calculation sheet available)

NVIS-Propagation Link calculation (single hop) via F2-Layer				
	DU1GS	07.10.2014		
Frequency (FOT)	7,2 MHz	only valid between 1,8-10 MHz		
D-Layer Day / Night	1	1 = Tag	0= Nacht	D-Layer switchable, Day / Night
Radiation angle	89°	for TX and RX-location		
Criticale Freq.	8,5 MHz	foF2	Radiation passes thru F2, -> lost in space	
D-layer attenuation	3,7 dB	thru the D-Layer		
D-layer attenuation	7,5 dB	for 1 Hop 2 Layers have to be passed		
TX-Power	25 W			
Height F2-layer	275 km	take from table for your location, default 350km		
Entfernung	10 km	ca. 10-700km distance on surface		
Total Radio path	550 km	Reflection at the F2-layer		
Attenuation	104,5 dB	Radio path		
The antenna used is an Inverted-Vee (G=6dBi), Apex approx. between 1/10 Lambda and max. L/4				
For good NVIS-connection TX and RX-Side use high angle antenna				
Inverted-Vee	30°	lower the ends to ground max. 45°		
Antenna gain 1	4,8	dBi for everage soil		
Inverted-Vee	30°	lower the ends to ground max. 45°		
Antenna gain 2	4,8	dBi for everage soil		
Margin	14,0 dB	Margin for 90% reliability		
Total loss	116,4 dB			
RSL (RX-Level)	-72,4 dBm	S9= -73dBm		

Ionogram / Ionosonde

To find the critical Frequency (foF2)

- http://www.ngdc.noaa.gov/stp/IONO/rt-iono/realtime/RealTime_foF2.html
- An Ionosonde transmit frequencies at approx. 1-20MHz vertical to the sky
- The time delay of the echoes from the ionosphere give information on the electron density in the ionosphere
- The produced picture (ionogram) by an ionosonde displays the distance of an echo on the vertical axis against frequency on the horizontal axis

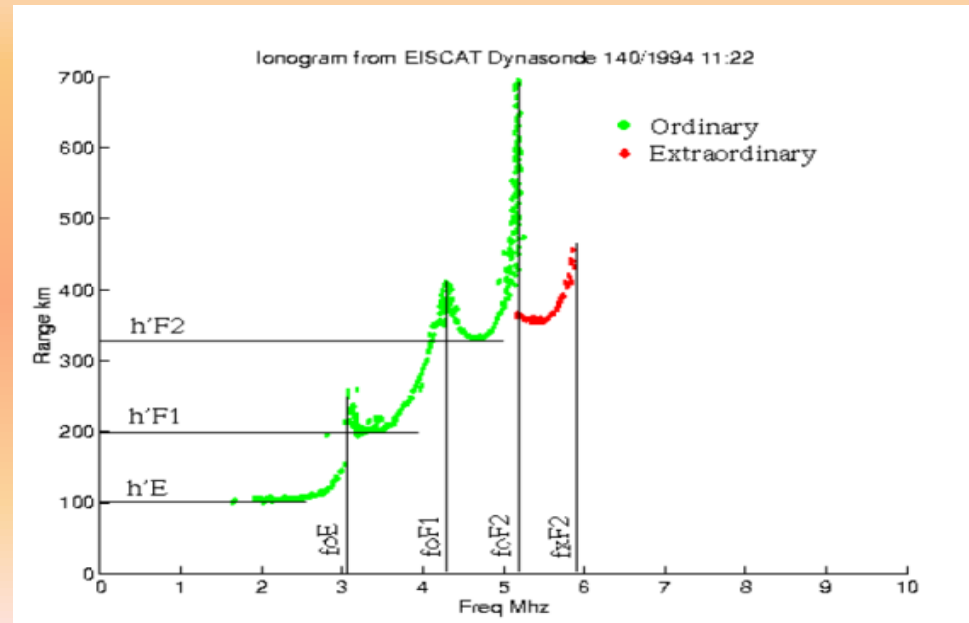

Sample of Criticale Frequency (CF)

- http://www.ngdc.noaa.gov/stp/IONO/rt-iono/realtime/RealTime_foF2.html
- Map of Sonde: <http://digisonde.com/digisonde-station-map.html>

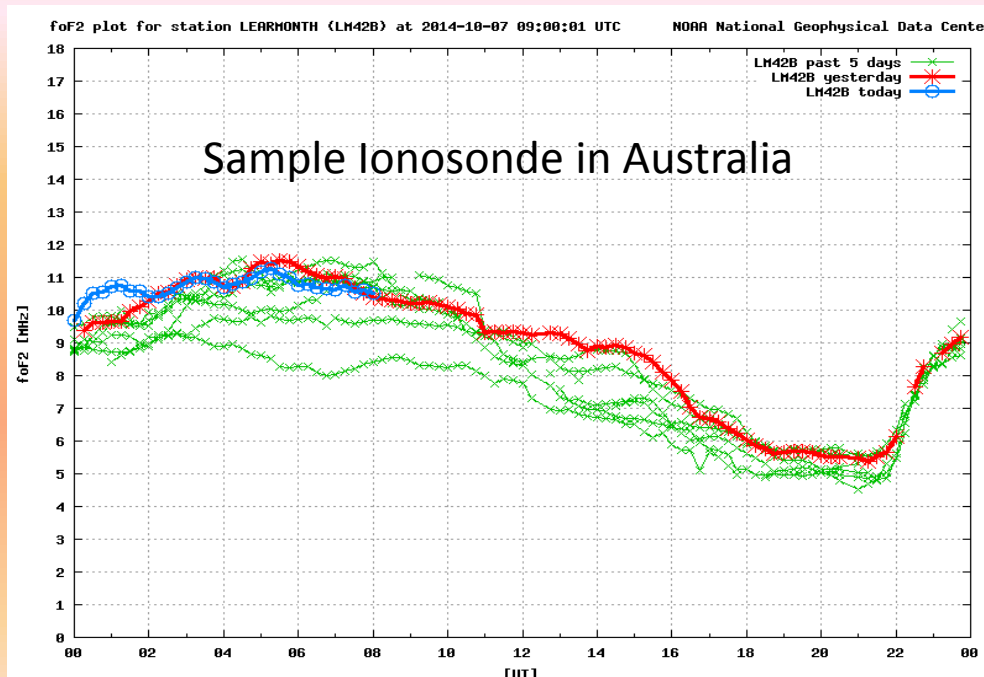

- Apps (MyHF_Map, EFLayer, NVISProp, MUF Predict) for Smartphone available

Frequency Selection for NVIS 1/2

Operation frequency has to be carefully selected

- Stay below the Critical Frequency (CF) of the foF2
- Best Operation Frequency is approx. 15% below the CF
- Solar activity, time of the day and seasons of the year effects the CF
- Freq. has to be high enough to minimize D-Layer attenuation
- Select a nearby Ionosonde or from programs by the Internet
- or from experience (see next page)

Frequency Selection for NVIS 2/2

- Periods of high solar activity
 - Daytime - 60, 40 m
 - Dawn / Dusk - 60 m
 - Nighttime - 60 and 80 m
- Periods of low solar activity
 - Daytime - 80, 60 and 40m
 - Dawn / Dusk - 80, 60 m
 - Nighttime - 80, (alternative 160 m)*
- Main operation bands are 80m, 60m und 40m
- Scheduled Frequency changes are needed

* but unpractically due to the great physical length of 80m for the dipole in Emergency Situation!

For NVIS calculations VOACAP Online

<http://www.voacap.com/prediction.html>

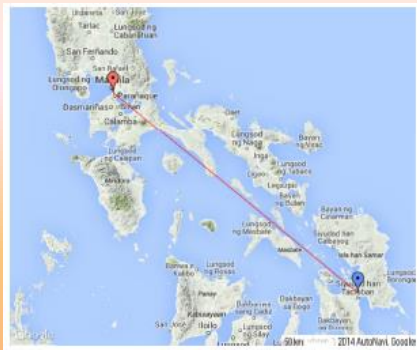

Can be used for NVIS and DX

The diagram shows for each hour the probability

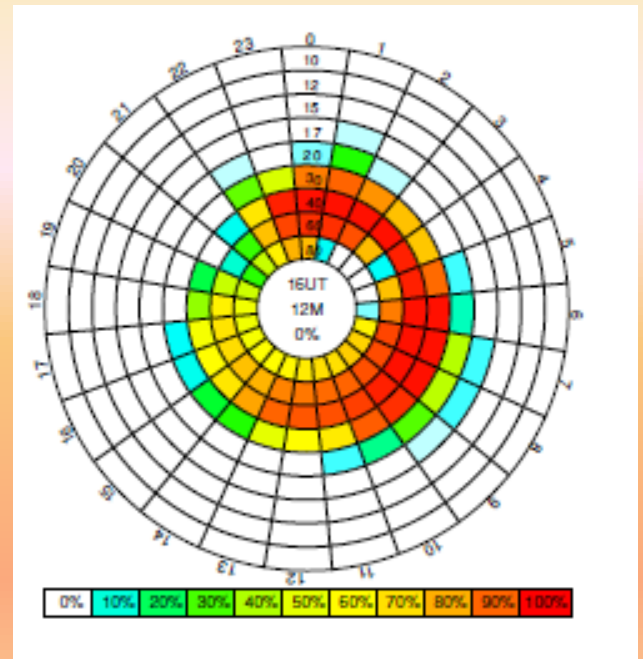

TX to RX: 561 km, 348 mi, 129 ° Year: 2014 Month: November

Propagation Params

Es: No Model: Auto
 SSN: 10 Min.TOA: 4 °

Today's Sunrise/Sunset Times (UTC)

	Transmitter		Receiver	
	Rise	Set	Rise	Set
GND	21:51	09:30	21:32	09:17
D	21:27	09:54	21:08	09:41
F	20:55	10:26	20:36	10:13

Transmitter Site

QTH: << Select a location >>
 Name: PK04mm
 Latitude: 14.5154 [-90..90]
 Longitude: 121.0054 [-180..180]
 TX antenna: Dipole @ 10M (33ft)
 TX power: 25 W
 TX mode: SSB
 Specials:
 Current point:

Receiver Site

QTH: << Select a location >>
 Name: PK21mh
 Latitude: 11.3248 [-90..90]
 Longitude: 125.0044 [-180..180]
 RX antenna: Dipole @ 10M (33ft)

Assignment of 60m-Band for Amateur Radio

- A significant gap in Spectrum exists between the 80m and the 40m-Band
- When the MUF is falling below 7 MHz and the lowest usable frequency (LUF) is above 4 MHz no communications for Radio Amateur's possible
- Need of 60m-Band especially in Dusk and Dawn for a reliable
24h Emergency Communications
- Temporary Solution could be: For Emergency Communications and Drill only, one or two Channels in the 60m-Band should be assigned **by the NTC**
This would make it possible to provide better Emergency Communications

World Radio Conference WRC 2015

- On the Agenda: Allocation of a worldwide 60m-Band to the Amateur Radio Services on secondary basis within 5250–5450 kHz

Emergency Communications

- NVIS provides communications up to approx. 400 mi and more
- With the proper Bands, day and night communications is possible
- Two stations using NVIS techniques can establish reliable communications without the support of any third party
- No infrastructure such as repeaters or satellite systems needed
- In an Emergency Communications Situation Amateurs can quickly establish reliable Radio connections
- Usable for various HF digital modes (RTTY, PSK31, Pactor etc.) which can run at 100% duty cycle, when TRX is set to 30W
(check for recommendation of the Manufacturer of your Radio!)

Internet Access in Emergency Situation with WinLink / Winmor

Further information please see: <http://www.winlink.org>

- A System to forward e-Mails in an Emergency Situation via Shortwave connections to so called RMS-Gateway (in Philippines for the time being: **4F7FDM in CEBU**)
- From the RMS msg will be forwarded to one of five different located Servers worldwide by Internet connection, but also Peer-to-Peer (P2P) is possible
- If no Internet is available also msg can/will be forwarded by Shortwave

Advantages:

- Cheap, no need to buy expansive TNC / Modem for the user
- Low-Power-Transceiver (25W)+ NVIS-Antenne (local) / Vertical (DX) + Netbook
- 500Hz modus provides robust Connection during QRM and
- 1600Hz provides fast data throughput (requires +6db more S/N)

Disadvantages:

- Not appropriate for large files (>20kb), mainly for Emergency usage

NVIS Operation

Planning is important

- NVIS net must have alternative Frequencies/Bands due to condx
- Procedures for frequency changes must be worked out, so stations don't get lost as the net moves from band to band, incl. alternative Freq.
- The Net Control Stations should determine the operating frequencies that will be used at various times of the day, according to pre-determined procedures
- Exercise drill is needed prior an Emergency Situation!

NVIS Propagation work as a System

Three important Factors for a successful NVIS Operation

- TX-Power

Can be often reduced due to high SNR

- Antenna

Antenne Height (less then $\lambda/4$, even $\lambda/10$ is fine)

- Frequency

15% below foF2 (see MUF-Factor for lower angle)

Operation procedures have to be established and also followed!

All Stations in a Network have to use NVIS-Antenna design

NVIS Antenna 1/2

- “Get your antenna up as high as you can get it! “
Wrong, ignore all this traditional advices, this will create the Skip zone!
- Antenna installation only 0.1λ to max. 0.25λ above ground
- Antenna can be installed at even lower heights, resulting in less gain
Even heights of 5 to 10 feet above ground are not unusual for NVIS setups
- Takeoff angle (TOA) are in the range of $50-90^\circ$, depending on distance
- Significant improvement in communication will be realized when both sites, the transmitting station and the receiving station are using NVIS antennas
- Low dipoles are easily to erect, e.g. get a rope over a low branch of a tree.
Masts made of PVC tubing are also practical at these heights

NVIS Antenna 2/2

Inverted Vee Antenna – simplest for NVIS

- Compared to a Dipole the Inverted-Vee is also a good NVIS antenna, which needs only one support (short centre Mast approx. 6-8m for 80-40m)
- An Inverted-Vee will work almost as well as a dipole
- Ends of the Antenne should be out of the reach of persons ($h > 2.5\text{m}$)
- **Counterpoises / Ground wire**
- The high angle radiation of a dipole (or inverted vee) can be enhanced by adding one or more counterpoise wire below it.
- Acts as a reflector (some inch, insulated from Ground)

Portable Antenna for NVIS

Inverted-Vee Dipole, needs only one support

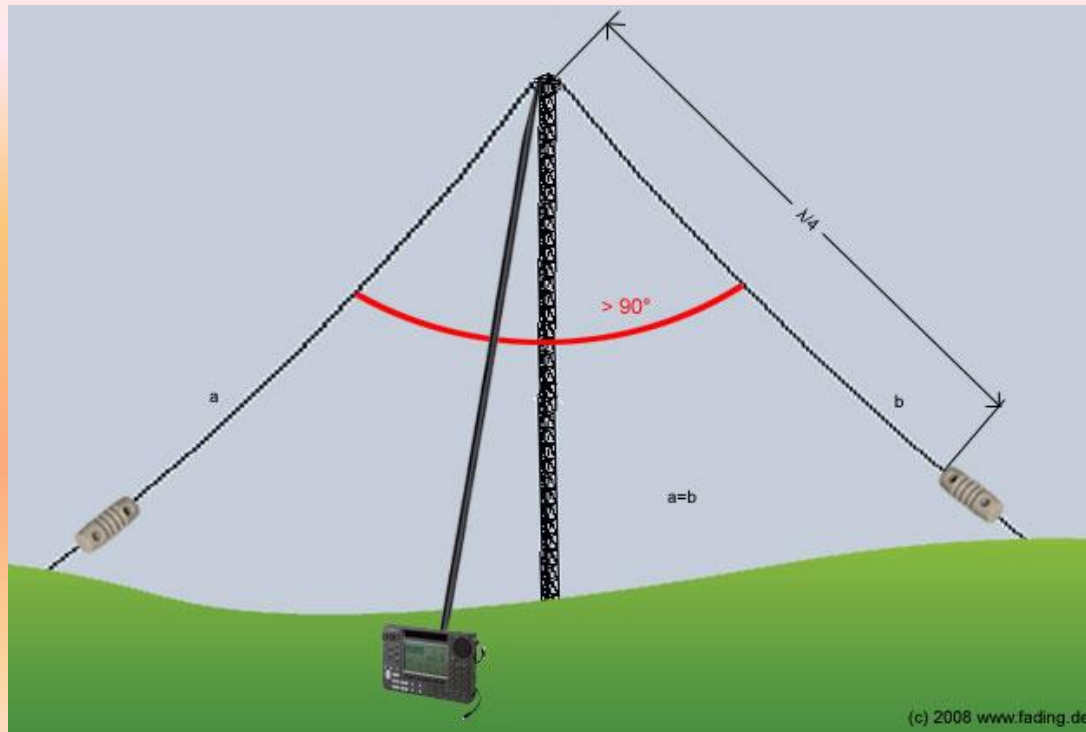

Multiband Operation with NVIS Dipoles

- Multiband-Dipole should be fed with ladder line or 300 Ω TV-ripped cable
- Manual Antenna Tuner with symmetrical Input (Balun 1:1) (due to various field deployment Impedance can vary, as well as due to low antenna installation!),
- Also Automatic Tuner with 1:1 current balun can be used
- Antenna must be less than 0.25λ for the highest Operation Frequency (typical $h = 6\text{m}$). (But for 160m-Band higher)
- Dipole, Windom and G5RV Antenna are good candidates

Setup a Portable Antenna System

- Reducing length (if needed) by bending back the ends of antenna, but if possible use it fully stretched

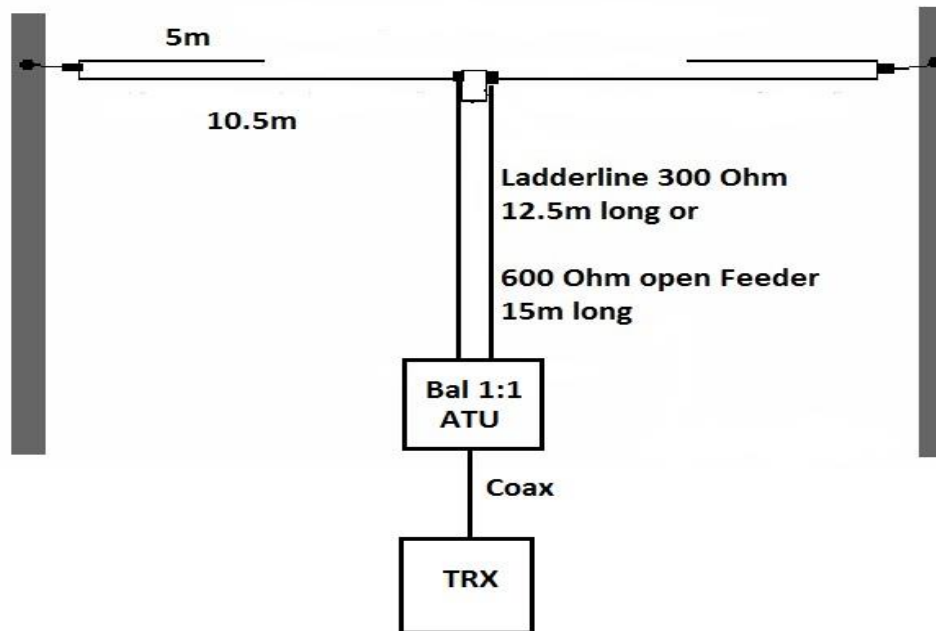

Antenna setup DU1GS

for NVIS-Propagation

The ends can be lowered
down as inverted-vee

Measurements:

Band	R+X	MFJ901B
80m	14-j70	4 - I - 4
60m	120-j260	4 - H - 4.5
40m	50+j190	5 - E - 3.5
30m	100-j530	3.5 F - 5
20m	55-j75	4 - C - 5

Mobile/Portable Antennas for NVIS

- Bending a mobile whip antenna down and away from the vehicle
- Or install a horizontal wire (approx. 10m for 40m) to the Mobile at 2–3m height, when “Mobile at Rest”

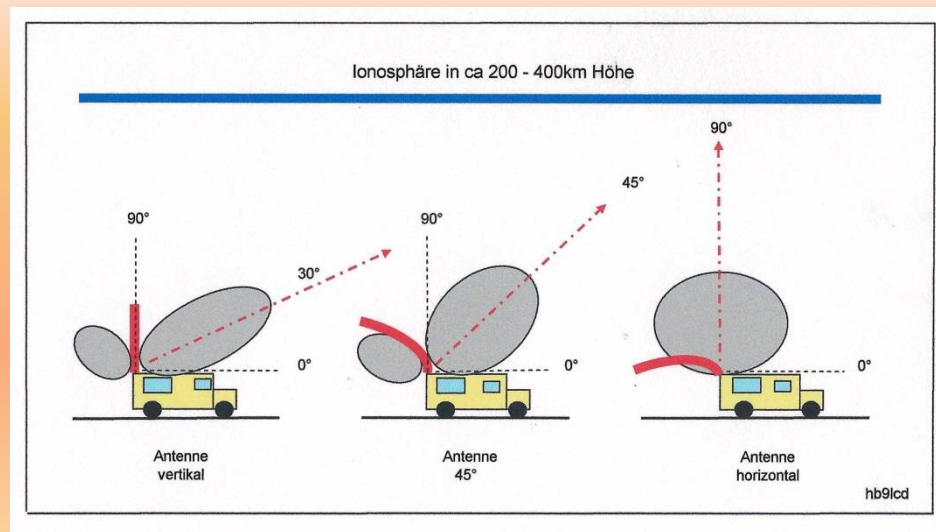

- Short horizontal dipole made by combining two loaded fiberglass whip antennas, designed for vehicle and used at height below 0.2λ

Very flexible Antenna for Portable

(wide Frequency Range)



My Portable Set

FT-450 (reduced Power < 50W) installed in a Fishing bag

- Powered by Battery 12V/12Ah
- Portable Fibre Mast (7m)
(on top VHF-Vertical antenna)
- G5RV-Multiband Antenna
- Incl. Manual Antenna Tuner
- Data Interface for Android-
Tablet 10" or PC (PSK, RTTY, etc)



Summary

- NVIS is a mode that many amateurs have used without recognizing it before
- It requires no special equipment, only very low installed antennas
- Both stations have to use NVIS-Antenna, as a System
- NVIS can provide good regional coverage with low TX-Power and produce high SNR. Good operating procedures have to be established
- NVIS is an operating mode that should be part of every Emergency Communications “tool kit”

**Disclaimer: I will not held liable for any damages or losses out of the content of this presentation.
Please take care by your own for any installations etc. out of this content.**

Credits: Near Vertical Incidence Sky Wave (NVIS) Propagation , Marc C. Tarplee, Ph.D. N4UFP

<http://n3ujj.com/manuals/Near%20Vertical%20Incidence%20Sky%20Wave%20Propogation.pdf>

http://www.arnoelettronica.it/index.php?option=com_content&view=article&id=20

End of Presentation

Thanks for your attention

Any Questions ???

Copies via PARA (Jojo)

Additional Information



MUF Factor

TOA (Rad.Angle)	90°	80°	70°	60°	50°	40°	30°	20°	10°
Multiplier	1.0	1.02	1.06	1.15	1.31	1.56	2.0	2.9	5.8

MUF-Multiplier (calculated using $1/\sin(\text{angle})$) to apply to the F2-layer critical frequency (CF) according the antenna main lobe radiation pattern.

For an angle of 40° for example the MUF is 1.56 times higher than the critical frequency (foF2) , jumping for example from 7 MHz (foF2) to 10.5 MHz MUF

Most important for DX-Connections,
Less for NVIS-Propagation, as high radiation antennas are used

foF2 Manila

During low solar activities

- <http://onlinelibrary.wiley.com/doi/10.1029/2010JA015250/pdf>

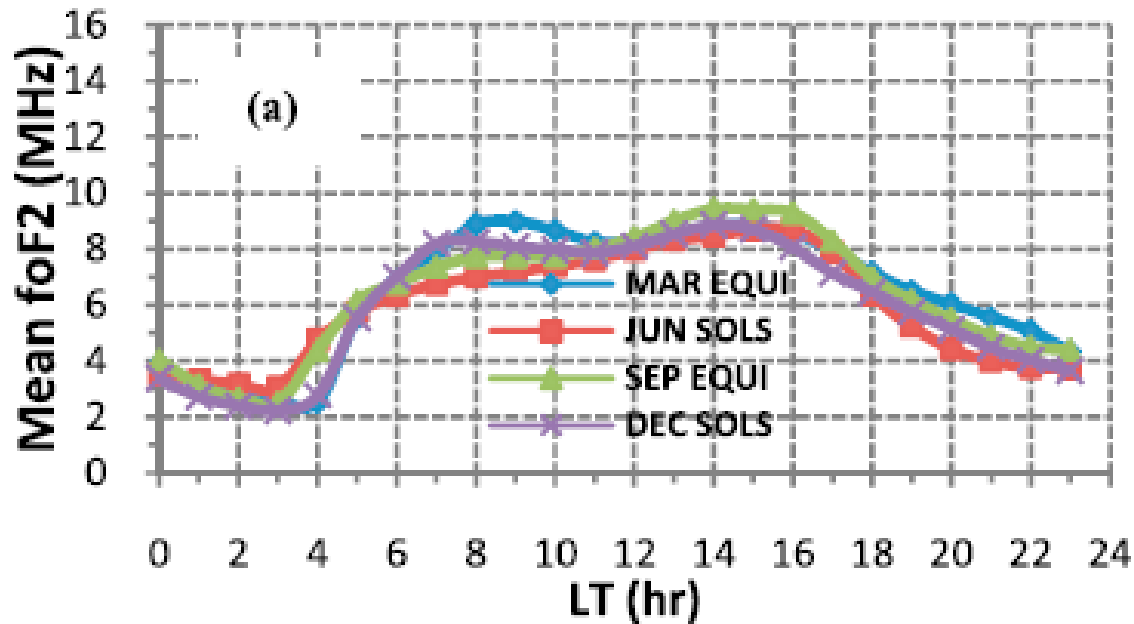

- During low solar activities for Manila (LT = local time)

foF2 Manila

During medium solar activities

- <http://onlinelibrary.wiley.com/doi/10.1029/2010JA015250/pdf>

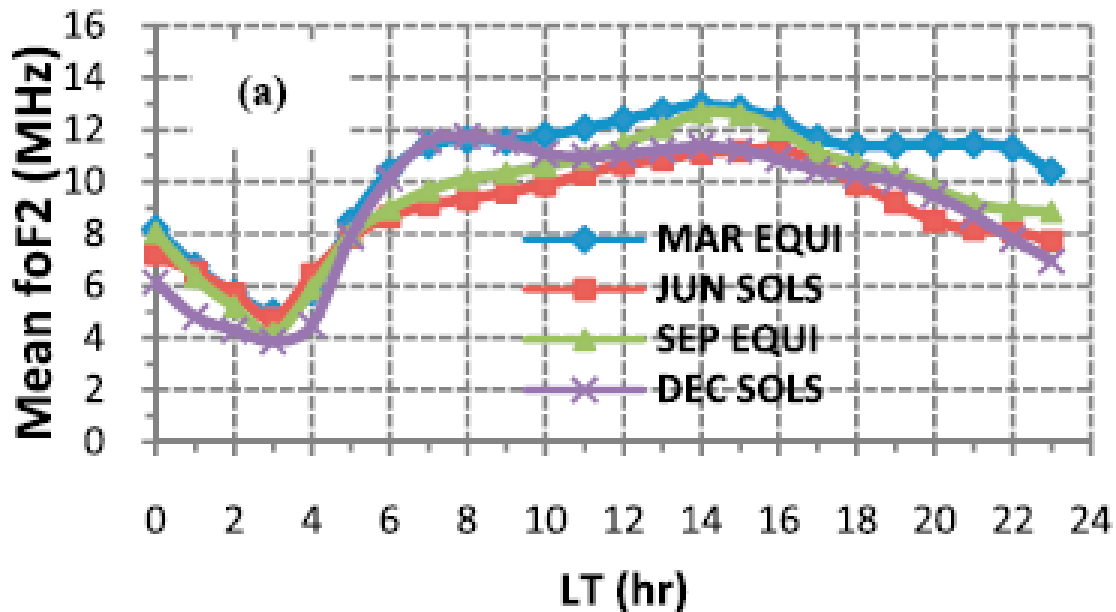

- During medium solar activities for Manila (LT = local time)

foF2 Manila

During high solar activities

- <http://onlinelibrary.wiley.com/doi/10.1029/2010JA015250/pdf>

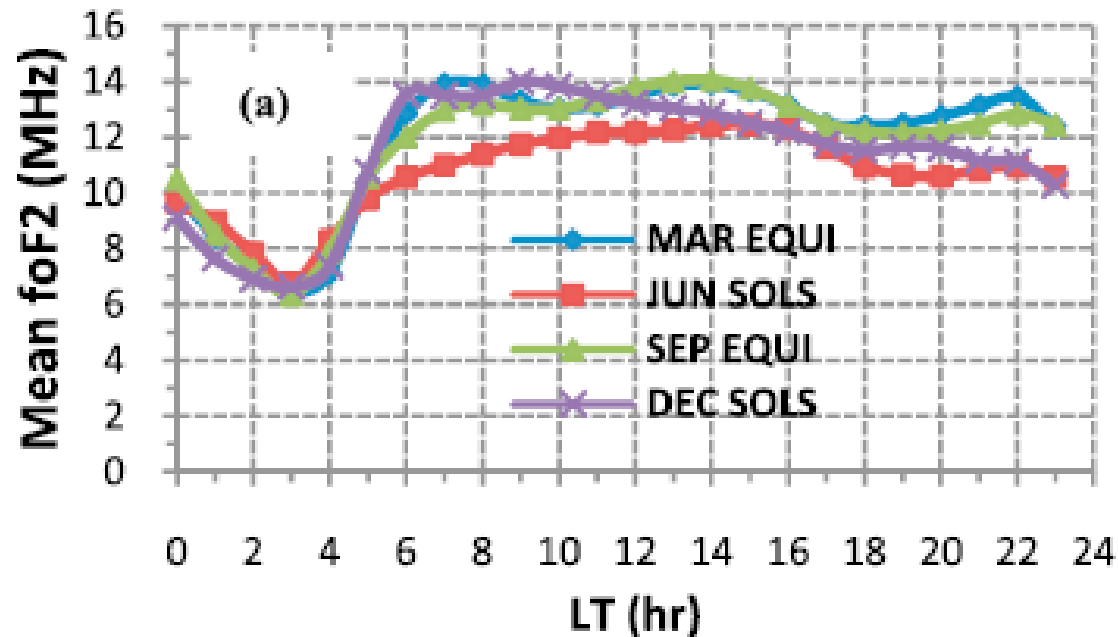

- During high solar activity for Manila (LT = local time)

20 Watts TRX for NVIS

http://www.wouxun.us/item.php?item_id=346&category_id=65

- Xiegu X108 QRP Transceiver (Price approx 600 US\$)
(not a recommendation from my side, only information)

