

NEET - 2013
(Physics, Chemistry and Biology)
Code - W
Answer Key and Solution

Answers

1	(1)	2	(3)	3	(2)	4	(1)	5	(3)	6	(1)	7	(2)	8	(1)	9	(4)	10	(2)
11	(4)	12	(1)	13	(4)	14	(2)	15	(2)	16	(2)	17	(4)	18	(3)	19	(1)	20	(1)
21	(4)	22	(1)	23	(2)	24	(2)	25	(4)	26	(2)	27	(2)	28	(2)	29	(4)	30	(2)
31	(2)	32	(4)	33	(1)	34	(1)	35	(2)	36	(3)	37	(3)	38	(1)	39	(3)	40	(3)
41	(2)	42	(3)	43	(3)	44	(1)	45	(3)	46	(3)	47	(4)	48	(3)	49	(2)	50	(3)
51	(3)	52	(4)	53	(1)	54	(1)	55	(2)	56	(4)	57	(3)	58	(3)	59	(1)	60	(2)
61	(3)	62	(2)	63	(1)	64	(2)	65	(4)	66	(4)	67	(4)	68	(4)	69	(2)	70	(1)
71	(3)	72	(3)	73	(3)	74	(2)	75	(3)	76	(2)	77	(2)	78	(3)	79	(3)	80	(3)
81	(1)	82	(2)	83	(4)	84	(2)	85	(2)	86	(3)	87	(3)	88	(1)	89	(2)	90	(3)
91	(3)	92	(3)	93	(2)	94	(2)	95	(4)	96	(3)	97	(2)	98	(1)	99	(1)	100	(2)
101	(3)	102	(2)	103	(3)	104	(3)	105	(4)	106	(2)	107	(3)	108	(1)	109	(4)	110	(2)
111	(4)	112	(2)	113	(4)	114	(4)	115	(3)	116	(1)	117	(3)	118	(4)	119	(3)	120	(2)
121	(2)	122	(1)	123	(2)	124	(4)	125	(2)	126	(1)	127	(3)	128	(3)	129	(4)	130	(1)
131	(3)	132	(3)	133	(3)	134	(1)	135	(3)	136	(1)	137	(3)	138	(3)	139	(2)	140	(3)
141	(3)	142	(4)	143	(4)	144	(1)	145	(4)	146	(1)	147	(1)	148	(1)	149	(3)	150	(3)
151	(1)	152	(1)	153	(2)	154	(3)	155	(1)	156	(1)	157	(3)	158	(3)	159	(4)	160	(1)
161	(4)	162	(1)	163	(4)	164	(3)	165	(3)	166	(3)	167	(3)	168	(3)	169	(1)	170	(1)
171	(3)	172	(1)	173	(1)	174	(4)	175	(1)	176	(4)	177	(1)	178	(3)	179	(1)	180	(2)

Physics

1. Given that $P = \frac{a^2 b^2}{cd}$

$$\therefore \frac{\Delta P}{P} = \pm \left[3 \frac{\Delta a}{a} + 2 \frac{\Delta b}{b} + \frac{\Delta c}{c} + \frac{\Delta d}{d} \right]$$

$$\rightarrow \text{Percentage error in } P, \frac{\Delta P}{P} \times 100\% = \pm [3 \times 1\% + 2 \times 2\% + 3\% + 4\%]$$

$$= \pm [3\% + 4\% + 3\% + 4\%] = \pm 14\%$$

Hence, the % error in P is 14%.

2. Given that the velocity of a projectile at the initial point A is $(2\hat{i} + 3\hat{j})$.

The horizontal component remains the same, while the vertical component changes.
So, the velocity at point B is

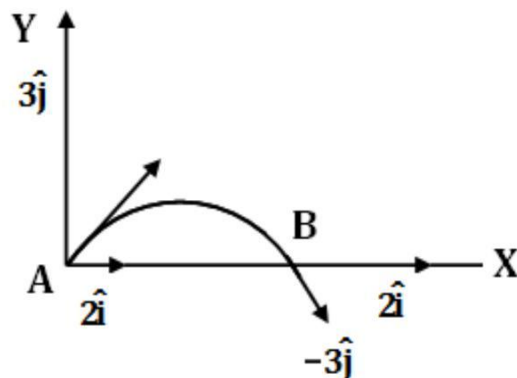

Velocity (in m/s) at point B, $v_f = (2\hat{i} - 3\hat{j})$

- 3.

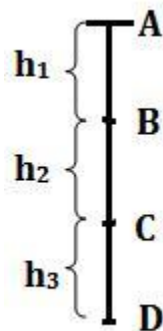

Let us assume that the stone falls freely from point A.

At A, $u = 0$

Distance covered in first 5 s is $s_1 = h_1$.

$$h_1 = \frac{1}{2}at^2$$

$$h_1 = \frac{1}{2}a(5)^2$$

$$\rightarrow h_1 = \frac{25a}{2} \text{ ----- (Equation 1)}$$

Distance covered in first 10 s is s_2 , i.e. from point A to C.

$$s_2 = 0 + \frac{1}{2}at^2$$

$$s_2 = \frac{1}{2}a(10)^2$$

$$\rightarrow s_2 = \frac{100a}{2} \text{ ----- (Equation 2)}$$

Thus, the distance covered in the next 5 seconds, i.e. from point B to C is

$$h_2 = s_2 - h_1$$

$$= \frac{100a}{2} - \frac{25a}{2}$$

$$h_2 = \frac{75a}{2} \text{ ----- (Equation 3)}$$

Distance covered in the first 15 s is s_3 , i.e. from point A to C.

$$s_3 = 0 + \frac{1}{2}at^2$$

$$s_3 = \frac{1}{2}a(15)^2$$

$$\rightarrow s_3 = \frac{125a}{2} \text{ ----- (Equation 4)}$$

Thus, the distance covered in the next 5 seconds, i.e. from point C to D is

$$h_3 = s_3 - s_2$$

$$= \frac{125a}{2} - \frac{100a}{2}$$

$$h_3 = \frac{25a}{2} \text{ ----- (Equation 5)}$$

Using equations (1), (3) and (5), we get h_1, h_2, h_3

$$\frac{25a}{2} = \frac{75a}{2} = \frac{125a}{2}$$

$$\therefore h_1 = \frac{h_2}{3} = \frac{h_3}{5}$$

4. The blocks are moving upward at constant speed 'v'.
 This implies that the acceleration 'a' is zero.
 We have $F = ma \rightarrow F = 0$
 That is $a \rightarrow 0 \Rightarrow F = 0$
 Hence, the net force on each block will be zero.

5.

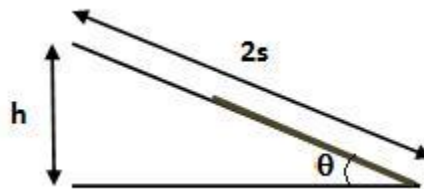

Let the length of the plane inclined at angle θ be 's' and height be 'h'.
 The work done is equal to the change in the kinetic energy which is equal to 0.
 Work done is equal to the work done against the gravitational force and against the frictional force. That is

$$\text{Work done} = W_{\text{gravity}} + W_{\text{friction}} = 0 \dots (\text{Equation 1})$$

$$W_{\text{gravity}} = mgh$$

$$W_{\text{friction}} = f \cdot s = -\mu mg \cos\theta s$$

Substituting in equation (1), we

$$\text{get } mgh - \mu mg \cos\theta s = 0$$

$$mgh = \mu mg \cos\theta s$$

$$\mu = \frac{h}{s \cos\theta} \dots \dots \dots (\text{Equation 2})$$

But from the diagram, we get

$$\frac{h}{2s} =$$

$$\rightarrow \frac{h}{s} = 2\sin\theta$$

Substituting in equation (2), we get

$$\mu = \frac{2\sin\theta}{\cos\theta}$$

$$\therefore \mu = 2\tan\theta$$

6. Given that the particle is displaced from position $(2\hat{i} + \hat{j})$ to $(4\hat{i} + 3\hat{j} - \hat{k})$.

Displacement 's' is calculated

$$\begin{aligned}\vec{s} &= (4\hat{i} + 3\hat{j} - \hat{k}) - (2\hat{i} + \hat{j}) \\ &= 4\hat{i} + 3\hat{j} - \hat{k} - 2\hat{i} - \hat{j} \\ &= 2\hat{i} + 2\hat{j} - \hat{k}\end{aligned}$$

Work done, $W = \vec{F} \cdot \vec{s}$

$$\begin{aligned}&= (3\hat{i} + \hat{j}) \cdot (2\hat{i} + 2\hat{j} - \hat{k}) \\ &= (3 \times 2) + (1 \times 2) + (0 \times (-1)) \\ &= 6 + 2 + 0 \\ &= 8\text{J}\end{aligned}$$

- 7.

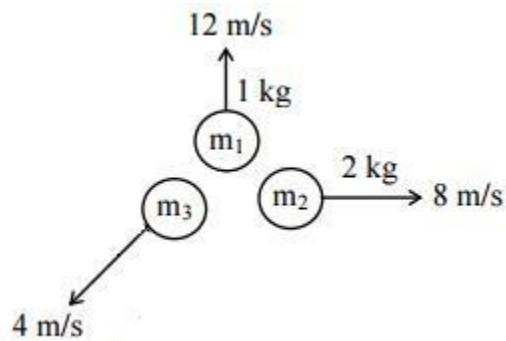

From the law of conservation of momentum, we get

$$\vec{P}_1 + \vec{P}_2 + \vec{P}_3 = 0$$

Given that two of the masses of rock go off at right angles to each other.

Let \vec{P}_1 and \vec{P}_2 be the momentum of the rocks that go off at right angles to each other.

$$\therefore |\vec{P}_3| = \sqrt{P_1^2 + P_2^2} \quad \text{-----} (\cdot v_1 \perp v_2)$$

$$m_3 v_3 = \sqrt{m_1 v_1^2 + m_2 v_2^2}$$

$$m_3 \times 4 = \sqrt{1^2 \times 12^2 + 2^2}$$

$$\times 8^2 \quad m_3 \times 4 = 20$$

$$\therefore m_3 = 5 \text{ kg}$$

8.

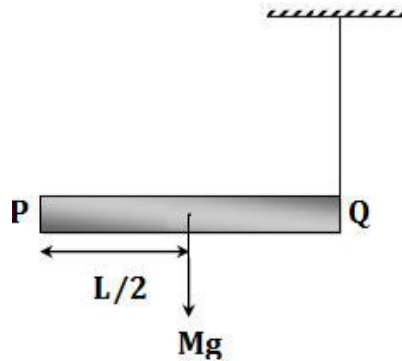

Torque of the rod PQ can be found using the torque formula of a thin rod. It is

$$\tau = I \alpha$$

$$F.r = I \alpha$$

For a rod, $I = \frac{ML^2}{3}$ and $F = Mg$

$$\therefore Mg \frac{L}{2} = \frac{ML^2}{3} \alpha$$

$$\therefore \alpha = \frac{3g}{2L}$$

9. From the conservation of mechanical energy, we get

$$\frac{1}{2} mv^2 \left(1 + \frac{K^2}{R^2} \right) = mgh$$

$$\text{Given that, } h = \frac{3v^2}{4g}$$

$$\Rightarrow \frac{1}{2} mv^2 \left(1 + \frac{K^2}{R^2} \right) = mg \left(\frac{3v^2}{4g} \right)$$

$$\therefore \frac{K^2}{R^2} = 1$$

$$\rightarrow K^2 = R^2 \frac{1}{2}$$

$$\text{But, } K = \sqrt{\frac{I}{M}}$$

$$\therefore \frac{I}{M} = R^2 \frac{1}{2}$$

$$\therefore I = \frac{1}{2} MR^2$$

So, the given object is a disc.

10. The change in potential energy is the difference between its final and initial potential energy.

$$U_f = \frac{-GMm}{R+2R} = \frac{-GMm}{3R};$$

$$U_i = \frac{-GMm}{R}$$

$$\therefore \Delta U = U_f - U_i$$

$$= \frac{-GMm}{3R} - \frac{-GMm}{R}$$

$$= \frac{GMm}{R} \left(1 - \frac{1}{3} \right)$$

$$= \frac{2GMm}{3R}$$

$$= \frac{2GMm \times R}{3R^2}$$

$$= \frac{2}{3} \left(\frac{GM}{R^2} \right) mR$$

$$= \frac{2}{3} gmR$$

$$\text{Or, } \Delta U = \frac{2}{3} mgR$$

11. Given that there are infinite number of bodies, each of mass 2 kg, situated on the x-axis at distances of 1 m, 2 m, 4 m, 8 m, respectively, from the origin.

Gravitation potential is

$$V = \frac{-GM}{R}$$

$$\therefore V = -GM \left[\frac{1}{1} + \frac{1}{2} + \frac{1}{4} + \frac{1}{8} + \dots \right]$$

$$V = -G \times 2 \left[\frac{1}{2} + \frac{1}{2} + \frac{1}{2} + \dots \right]$$

$$V = -4G \left[1 + \frac{1}{2} + \frac{1}{4} + \dots \right]$$

$$V = -4G \left(1 - \frac{1}{2} \right)$$

$$\therefore V = -4G$$

12. Young's modulus for a wire is

$$Y = \frac{MgL}{A\Delta L} = \text{Constant}$$

$$\therefore \Delta L = \frac{MgL}{AY}$$

$$\Delta L \propto \frac{MgL}{AY}$$

$$\text{Or, } \Delta L \propto \frac{L}{A}$$

Among the given options, the ratio of L/A is maximum for $L = 50$ cm and $D = 0.5$ mm. Hence, option (1) is correct.

13. Wetting is the ability of a liquid to maintain contact with a solid surface and the degree of wetting is known as wettability. It depends on the angle of contact between the surface and the liquid

14. Difference between two molar specific heats is

$$C_p - C_v = R$$

Dividing both the sides by C_v , we get

$$\frac{C_p}{C_v} - \frac{C_v}{C_v} = \frac{R}{C_v}$$

$$\text{But, } \frac{C_p}{C_v} = \gamma$$

$$\therefore \gamma - 1 = \frac{R}{C_v}$$

$$\therefore C_v = \frac{R}{\gamma - 1}$$

15. It can be explained using the Wien's displacement law

$$\lambda_{\max} \propto \frac{1}{T}$$

$$\text{Or, } \lambda_{\max} \propto \frac{1}{T} \therefore \lambda_{\max} T = \text{constant}$$

16. We know that

Net work done by the gas = Area under the P-V curve

$$\begin{aligned} &= \frac{1}{2} \times 4 \times 10^5 \times 5 \times 10^{-3} \\ &= 10 \times 10^2 \\ &= 1000 \text{ J} \end{aligned}$$

17. Given that $P \propto T^3$

But for an adiabatic process, $P \propto T^{\gamma/\gamma-1}$

$$\therefore \frac{\gamma}{\gamma-1} = 3$$

$$\gamma = 3\gamma - 3$$

$$\therefore \gamma = \frac{3}{2}$$

18. Assuming the graph for a gas of given mass, the ideal gas equation is $PV = nRT$

$$\text{Or, } \frac{V}{T} \propto \frac{1}{P}$$

Form the graph, the slope = $\frac{V}{T} = \tan\theta$

$$\therefore \frac{1}{P} \propto \tan\theta$$

Thus, if θ increases, $\tan\theta$ increases and the pressure decreases.

$$\text{As } \theta_1 < \theta_2 \rightarrow \frac{1}{P_1} < \frac{1}{P_2}$$

$$\Rightarrow P_2 < P_1$$

19. The amount of energy required to raise the temperature of 1 g of helium at NTP, from $T_1\text{K}$ to $T_2\text{K}$ is

$$E = \frac{f}{2} nRT$$

$$\text{Or, } E = \frac{f}{2} NKT$$

But, $N = n.N_A$

$$\therefore E = \frac{f}{2} n.N_A k_B (T_2 - T_1)$$

Where, $k_B = \text{Boltzmann constant}$

$$E = \frac{3}{2} n N_A k_B (T_2 - T_1) \quad \therefore$$

For He, 4 gm \rightarrow 1 mole

$$\therefore 1 \text{ gm} \rightarrow \frac{1}{4} \text{ mole} = n$$

$$\therefore E = \frac{3}{8} N_A k_B (T_2 - T_1)$$

20. The equation of a wave travelling along the x-axis

$$\text{is } y = a \sin(\omega t - kx)$$

$$\text{Or, } y = a \sin(kx - \omega t)$$

$$\text{Given that } \lambda = 2\pi \text{ m; } f = \frac{1}{\pi} \text{ Hz}$$

$$\therefore k = \frac{2\pi}{\lambda} = \frac{2\pi}{2\pi} = 1$$

$$\omega = 2\pi \nu = 2\pi \times \frac{1}{\pi} = 2$$

$$\therefore y = \sin(x - 2t)$$

$$\rightarrow a = 1$$

21. In case of the vibration of a pipe open at both ends, the air column can vibrate in several different modes subjected to the boundary condition that there must be an antinode at its open end. Hence, option (1) is correct.

Ratio of frequency

$$\text{is } \nu : 2\nu : 3\nu : 4\nu : 5\nu$$

$$\text{where } \nu = \frac{V}{2L}$$

Both odd and even harmonics will be present.

Hence, options (1), (2) and (3) are correct.

The pressure variation is minimum at the antinode.

Hence, option (4) is incorrect.

22. Let the frequency of unknown source be 'x'.

$$x = 250 \pm 4 = 246 \text{ Hz or } 254 \text{ Hz}$$

$$\text{Second harmonic of this source, } 2x = 513 \pm 5 = 508 \text{ Hz or}$$

$$518. \therefore x = 259 \text{ or } 254$$

$$\Rightarrow x = 254 \text{ Hz}$$

23.

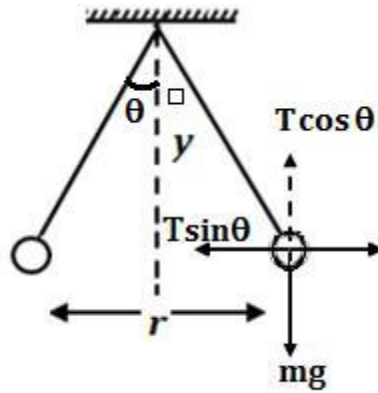

In the equilibrium position,

$$T \cos \theta = mg ;$$

$$T \sin \theta = F_e = \frac{Kq^2}{r^2}$$

$$\therefore \tan \theta = \frac{Kq^2}{r^2 mg}$$

From the diagram, we get $\tan \theta = \frac{r/2}{y}$

$$\therefore \frac{r/2}{y} = \frac{Kq^2}{r^2 mg}$$

$$\rightarrow y = \frac{r^3 mg}{2Kq^2}$$

$$y \propto r^3$$

$$\text{Or, } r \propto y^{1/3}$$

The equilibrium separation for $(y/2)$ is given as

$$r' \propto \left(\frac{y}{2} \right)^{1/3}$$

$$\rightarrow r' \propto \frac{r}{2^{1/3}}$$

24. Electric potential decreases in the direction of the electric field. The electric field is from high potential to low potential.

$$\text{i.e. } V_B > V_C > V_P$$

So, the potential is maximum at B.

25. Let R_1 be the resistance and l_1 be the length of the wire.

$$\text{Resistance, } R = \rho \frac{l}{A} \text{ When volume is constant}$$

$$A \propto \frac{1}{l}$$

$$R \propto l^2$$

Resistance ' R_2 ' of the stretched wire is given as

$$R_2 = 4R_1$$

$$= 4 \times 4$$

$$\therefore R_2 = 16\Omega$$

26. Given that $I = 0.2 \text{ V}$, $E = 2.1 \text{ V}$ and $R = 10 \Omega$.

$$I = \frac{E}{R + r}$$

$$0.2 = \frac{2.1}{10 + r}$$

$$0.2r = 0.1$$

$$\therefore r = 0.5 \Omega$$

27.

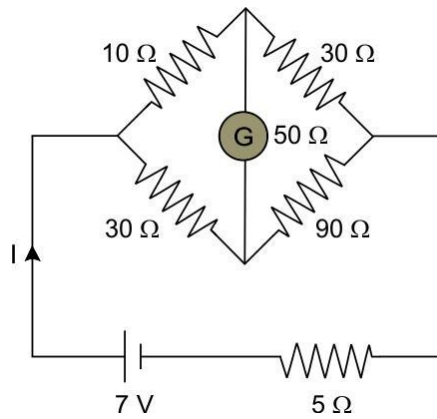

For a balanced Wheatstone's bridge,

$$\frac{P}{Q} = \frac{R}{S}$$

$$\begin{aligned} \text{Equivalent resistance, } R_{eq} &= \frac{(10 + 30)(30 + 90)}{(10 + 30 + 30 + 90)} \\ &= \frac{40 \times 120}{160} \\ &= 30 \Omega \end{aligned}$$

Now, the effective resistance $R_{\text{eff}} = 30 + 5 = 35 \Omega$

$$\text{Current, } I = \frac{V}{R_{\text{eff}}}$$

$$= \frac{7}{35}$$

\therefore Current, $I = 0.2 \text{ A}$

28.

Acceleration of charged particle, $\vec{a} = \frac{q}{m} (\vec{E} + \vec{v} \times \vec{B})$

When rested from rest, $\vec{a} = \vec{a}_0 = \frac{q}{m} \vec{E}$

$$\therefore \vec{E} = \frac{m\vec{a}_0}{q} = \frac{m\vec{a}_0}{e} \text{ (in west direction)}$$

Magnetic force = $F_m = 3ma_0 - ma_0 = 2ma_0$ (in the west direction) $\vec{v} \times \vec{B}$ is directed towards the west.

For positive charge, \vec{v} is directed towards the North and \vec{B} is directed vertically down.

$$\vec{F}_m = q\vec{v} \times \vec{B} \therefore$$

$$2ma_0 = ev_0 \times B$$

$$B = \frac{2ma_0}{ev_0} \text{ (in vertically downward direction)}$$

29. It is in equilibrium for two orientations (0° and 180°).

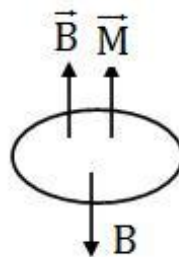

$\theta = 0^\circ$ stable equilibrium (parallel)

$\theta = 180^\circ$ unstable equilibrium (anti-parallel)

30. Let magnetic pole strength be m , then

$$M = m\ell$$

In the second case,

$$\ell = r\theta = r \left(\frac{\pi}{3} \right)$$

$$r = \frac{3\ell}{\pi}$$

$$\text{Now, } M' = (m) 2r \sin \left(\frac{60^\circ}{2} \right)$$

$$\rightarrow M' = 2m \left(\frac{3}{\pi} \right) \left(\frac{1}{2} \right)$$

$$\rightarrow M' = \frac{3m}{\pi} \ell$$

$$\therefore M' = \frac{3M}{\pi}$$

31.

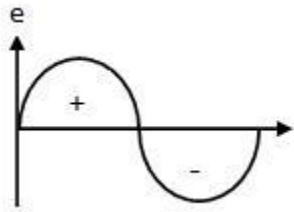

For a rotating coil, $e = N\omega AB \sin \omega t$

The frequency of change of direction of EMF is twice per revolution.

32. Impedance is

$$Z = \frac{\sqrt{R^2 + X_L^2}}{R^2 + (L \times 2\pi f)^2}$$

If the frequency of the AC source is decreased, then the impedance decreases \rightarrow intensity increases.

If the number of turns decreases, self-inductance decreases and thus impedance decreases \rightarrow brightness increases.

At resonance, $X_C = X_L$ and impedance decreases \rightarrow brightness increases.

When an iron rod is inserted, impedance increases, and hence, current decreases \rightarrow brightness decreases.

33. In the presence of microwaves, the water molecules oscillate in the electric field of microwaves. This results in the generation of heat. The amplitude of oscillation will be maximum when the frequency of the microwaves matches the resonant frequency of water molecules. Thus, for effective working, the microwaves must operate near the natural frequency of vibration of the water molecules.

34.

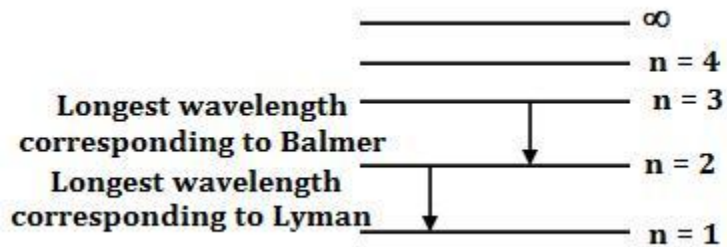

Rydberg formula is given as

$$\frac{1}{\lambda} = R \left(\frac{1}{n'^2} - \frac{1}{n^2} \right)$$

For Lyman series,

$$\frac{1}{\lambda} = R \left(\frac{1}{1^2} - \frac{1}{2^2} \right)$$

$$\frac{1}{\lambda_{\ell}} = \frac{3R}{4}$$

$$\therefore \lambda_{\ell} = \frac{4}{3R} \text{ ----- (Equation 1)}$$

For Balmer series,

$$\frac{1}{\lambda_b} = R \left(\frac{1}{2^2} - \frac{1}{3^2} \right)$$

$$\frac{1}{\lambda_{\ell}} = \frac{5R}{36}$$

$$\therefore \lambda_{\ell} = \frac{36}{5R} \text{ ----- (Equation 2)}$$

$$\frac{\lambda_{\ell}}{\lambda_b} = \frac{4 \times 5R}{3R \times 36}$$

$$\therefore \frac{\lambda_{\ell}}{\lambda_b} = \frac{5}{27}$$

35. Given that

Decay equation

$$\text{is } N = N_0 e^{-\lambda t}$$

$$\frac{N_x}{N_y} = \frac{1}{7}$$

$$\Rightarrow N_x + N_y = N_0 = 8 = 2^3$$

$$\therefore n = 3$$

$$\text{But, } n = \frac{t}{T}$$

Given that $T = 20$ years

$$t = 3 \times 20 = 60 \text{ years}$$

36. Given that

$$\text{Mass defect} = \Delta m = 0.02866$$

$$\begin{aligned} \text{u Total energy} = E &= \Delta m c^2 \\ &= 0.02866 \times 931 \text{ MeV} \\ &= 26.68 \text{ MeV} \end{aligned}$$

$$\begin{aligned} \text{Energy liberated per u} &= \frac{E}{A} \\ &= \frac{26.68}{4} \\ &= 6.678 \text{ MeV} \end{aligned}$$

37. Cut off frequency = ν Work

function $\phi = h\nu$ Now, $E =$

Kinetic energy + ϕ

$$h(2\nu) = \frac{1}{2} m v^2 + h\nu$$

$$\frac{1}{2} m v^2 = h\nu$$

$$\therefore v = \sqrt{\frac{2h\nu}{m}}$$

38. For an electron, the de Broglie's wavelength is

$$\lambda_e = \frac{h}{\sqrt{2mE}}$$

$$\text{Or, } \lambda_e \propto \frac{1}{\sqrt{E}} \rightarrow \lambda_e^2 \propto \frac{1}{E} \text{ ----- (Equation 1)}$$

For a photon the wavelength is given as

$$\lambda_p = \frac{hc}{E}$$

$$\text{Or, } \lambda_p \propto \frac{1}{E} \text{ ----- (Equation 2)}$$

From equation (1) and (2), we get

$$\lambda_p \propto \lambda_e^2$$

39.

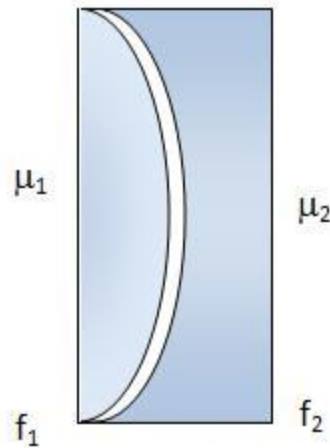

Lens maker's formula is

$$\frac{1}{f} = (\mu - 1) \left(\frac{1}{\infty} + \frac{1}{R_2} \right)$$

For a plano-convex lens, the formula is given as

$$\begin{aligned} \frac{1}{f_1} &= (\mu_1 - 1) \left(\frac{1}{\infty} - \frac{1}{-R} \right) \\ &= \frac{\mu_1 - 1}{R} \text{ ----- (Equation 1)} \end{aligned}$$

For a plano-concave lens, the formula is given as

$$\begin{aligned} \frac{1}{f_2} &= (\mu_2 - 1) \left(\frac{1}{R} - \frac{1}{\infty} \right) \\ \frac{1}{f_2} &= \frac{-(\mu_2 - 1)}{R} \text{ ----- (Equation 2)} \end{aligned}$$

From equation (1) and (2), the net focal length of combination is given as

$$\begin{aligned} \frac{1}{f} &= \frac{1}{f_1} + \frac{1}{f_2} \\ &= \frac{\mu_1 - 1}{R} - \frac{\mu_2 - 1}{R} \\ &= \frac{\mu_1 - 1 - \mu_2 + 1}{R} \\ &= \frac{\mu_1 - \mu_2}{R} \\ \therefore f &= \frac{R}{\mu_1 - \mu_2} \end{aligned}$$

40.

$$\frac{1}{f} = \frac{1}{f_1} + \frac{1}{f_2} = P_1 + P_2$$

lens + cornea forms an image of distance object at retina.

$$\therefore \text{Converging power} = P_1 + P_2 = (40 + 20) \text{ D} = 60 \text{ D}$$

$$\therefore \frac{1}{f} = \frac{1}{60} \text{ m} = \frac{100}{60} \text{ cm}$$

$$\therefore \frac{1}{f} = 1.67 \text{ cm}$$

41. For a bright fringe, the fringe width formula is

$$y = \frac{n\lambda D}{d}$$

$$\therefore \frac{n_1 \lambda_1 D}{d} = \frac{n_2 \lambda_2 D}{d}$$

$$\rightarrow \frac{n_1}{n_2} = \frac{\lambda_2}{\lambda_1} = \frac{10000 \text{ \AA}}{12000 \text{ \AA}} = \frac{5}{6}$$

$$\therefore n_1 = 5 \text{ and } n_2 = 6$$

$$\rightarrow y = \frac{n_1 \lambda_1 D}{d} = \frac{5 \times 12000 \times 10^{-10}}{2 \times 10^{-3}}$$

$$\therefore y = 6 \times 10^{-3} \text{ m} = 6 \text{ mm}$$

42. de Broglie's wavelength is

$$\lambda = \frac{h}{mv}$$

$$\therefore \lambda \propto \frac{1}{v}$$

→ If the speed of the electron increases, its de-Broglie wavelength decreases. Angular width for central minimum is given as

$$\omega = \frac{2\lambda}{d}$$

$$\therefore \omega \propto \lambda$$

$$\rightarrow \omega \propto \lambda \propto \frac{1}{v}$$

∴ On increasing the speed of electrons, λ decreases, and hence, the angular width of central maximum will decrease.

43. The N-type impurity loses its extra valence electron easily when added to a semiconductor material. In an n-type semiconductor, the pentavalent atoms are dopants, electrons are majority carriers and holes are minority carriers.

44. We know that Voltage

$$\text{gain, } A_v = \beta \frac{R_o}{R_{in}}$$

$$= \frac{I_c R_o}{I_b R_{in}}$$

$$= \frac{I_c R_o}{V_{in}} \quad (V_{in} = I_{in} R_{in})$$

$$= g_m R_o \quad \text{(where, } g_m \text{ is the transductance)}$$

$$\therefore A_v \propto g_m$$

$$\therefore \frac{A_{v1}}{A_{v2}} = \frac{g_{m1}}{g_{m2}} = \frac{0.03}{0.02} = \frac{3}{2}$$

$$\therefore A_{v2} = \frac{2}{3} A_{v1}$$

$$\rightarrow \therefore A_{v2} = \frac{2}{3} G$$

45. The truth table for the combination of logic gates is

A	B	Y	X
0	0	1	0
0	1	1	0
1	0	1	0
1	1	0	1

NAND + NOT = AND

Output, $Y = \overline{\overline{A \cdot B}} = A \cdot B$

Chemistry

46.

We know $c = \lambda \nu$

$$\lambda = \frac{c}{\nu} = \frac{3 \times 10^{17} \text{ nm s}^{-1}}{6 \times 10^{15} \text{ s}^{-1}} = 50 \text{ nm}$$

47. The maximum number of electrons which can be associated when $n = 3$, $l = 1$ and $m = -1$ is 2.

48.

$$\log \frac{k_2}{k_1} = \frac{E_a}{2.303R} \left[\frac{T_2 - T_1}{T_1 T_2} \right]$$

$$\log 2 = \frac{E_a}{2.303 \times 8.314} \left[\frac{293 - 308}{293 \times 308} \right]$$

$$E_a = \frac{0.301 \times 2.303 \times 8.314 \times 293 \times 308}{15} = 34.67 \text{ kJ mol}^{-1}$$

49.

The reaction can be represented as

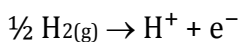

$$E_{\text{ox}} = E_{\text{ox}}^{\circ} - \frac{0.059}{n} \log \frac{[\text{H}^+]}{(\text{P})^{1/2}_{\text{H}_2}}$$

Since $\text{pH} = 10$, $[\text{H}^+] = 10^{-10} \text{ M}$

$$\text{So, } E_{\text{ox}} = 0 - \frac{0.059}{1} \log \frac{10^{-10}}{(1)^{1/2}}$$

$$E_{\text{ox}} = 0.59 \text{ V}$$

50. In the reaction, $[E_a]_{\text{forward}} = [E_a]_{\text{backward}}$

So, $H = 0$

51.

We know degree of ionization = $\frac{\lambda_m}{\lambda} \times 100$

$$= \frac{9.38 \times 100}{238}$$

$$= 4.008\%$$

52. The electrons closer to the nucleus are more strongly bonded.

53. $E^{\circ}_{\text{cell}} = E^{\circ}_{\text{cathode}} - E^{\circ}_{\text{anode}}$

$$= 0.34 - (-0.76) = 1.1 \text{ V}$$

54.

$$\text{Moles of HNO}_3 = \frac{W \times 1000}{\text{Molar mass} \times V}$$

$$2 = \frac{W \times 1000}{63 \times 250}$$

$$W = 31.5 \text{ g}$$

Now, 70 g is dissolved in 100 g of water

$$\text{So } 31.5 \text{ g HNO}_3 \text{ will be present in } = \frac{100 \times 31.5}{70} = 45 \text{ g of solution}$$

55. The number of atoms present in a diamond cubic unit cell = $\frac{1}{8} \times 8 + \frac{1}{2} \times 6 + 4 = 8$ atoms

56. Maximum deviation from the ideal gas is expected from $\text{NH}_3(\text{g})$.

57.

$$\rho = \frac{Z \times M}{N_A \times V}$$

$$2.72 = \frac{4 \times M}{6.023 \times 10^{23} \times (4.04 \times 10^{-8})^3}$$

$$M = \frac{2.72 \times (4.04)^3 \times 6.023 \times 10^{-1}}{4} = 27 \text{ g/mol}$$

58. We know HCl is a polar molecule and thus induces dipole in the He atom.

59.

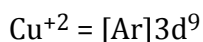

$$\therefore n = 1$$

$$\mu = \sqrt{n(n+2)} = \sqrt{1(1+2)} = \sqrt{3} \text{ BM}$$

$$\mu = 1.73 \text{ BM}$$

60. The gas X is SO_2 .

61. HClO_4 is the strongest acid.

62. O_2^- contains one unpaired electron and hence is paramagnetic.

63. The BN structure is similar to graphite.

64. The basic structural unit of silicates is SiO_4^{4-} .

65. It is Clemmensen reduction and is used only for:

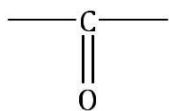

66. $(\text{NH}_4)_2\text{Cr}_2\text{O}_7 \xrightarrow{\Delta} \text{N}_2 + \text{Cr}_2\text{O}_3 + 2\text{H}_2\text{O}$

67. Yb^{2+} has electronic configuration $4f^{14}$ and hence is diamagnetic.

68. $\text{Na}_2\text{S} > \text{ZnS} > \text{CuS}$

69.

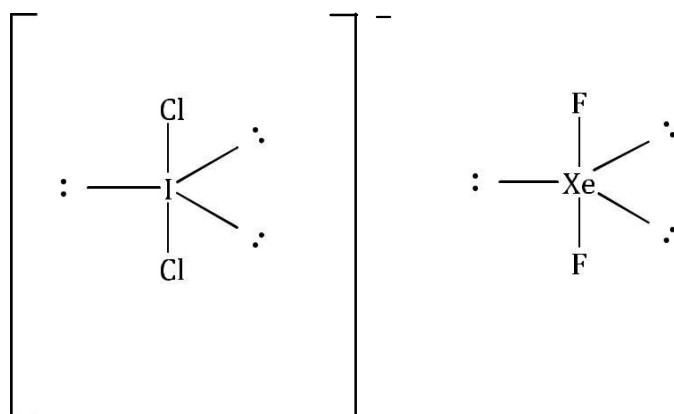

70. $[\text{CrCl}_2(\text{H}_2\text{O})_4]\text{Cl}$

Because 0.01 mole of Cl^- ions are present in 100 ml. So, in 1000 ml = $0.01 \times 0.1 = 0.001$

71. BF_3 acts as a Lewis acid because it is electron deficient.

72. The reaction can go to completion by removing OH^- ions by adding CO_2 .

73. $(\text{BH}_3)_2$ is electron deficient.

74.

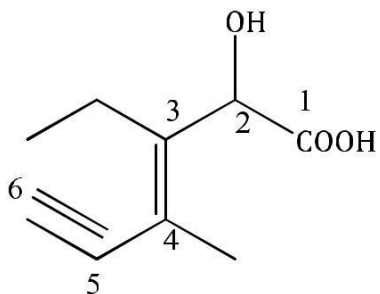

3-Ethyl-2-hydroxy-4-methyl hex-3-en-5-ynoic acid

75. Me_3SiCl is not a monomer for a high molecular mass silicone polymer.

76. They are chemically inert.

77. Water does not contain π bond.

78. Dilute solutions of boric acid and hydrogen peroxide are mild antiseptics.

79.

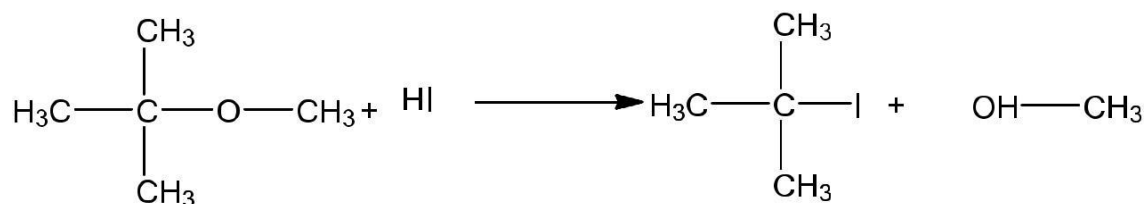

80. Nylon is an example of polyamide.

81.

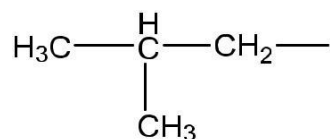

82.

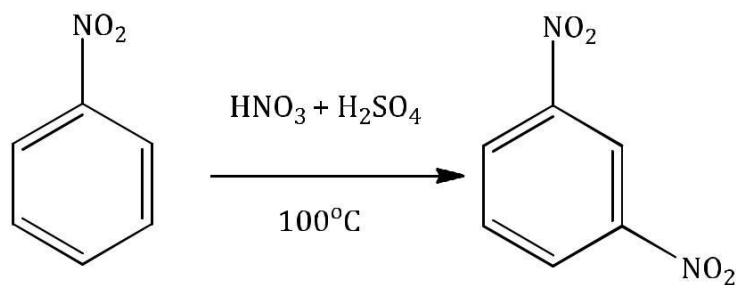

83. $-\text{NO}_2$ is the most deactivating.

84.

$$M = \frac{\left[\frac{6.02 \times 10^{20}}{6.02 \times 10^{23}} \right]}{1000} = 0.01\text{M}$$

85. $\mu \neq 0$ and is therefore polar.

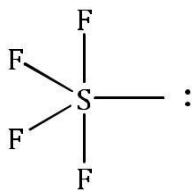

86.

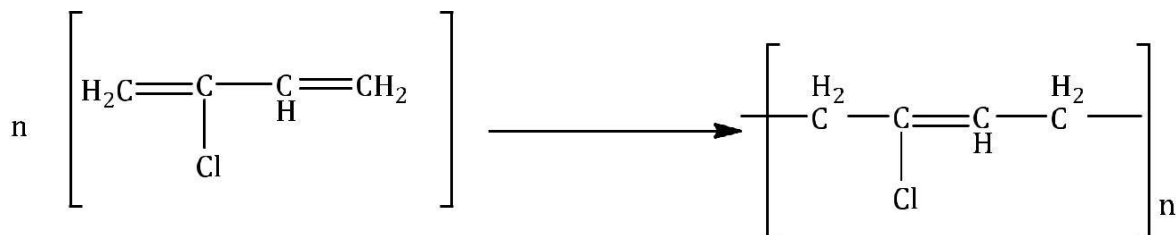

Chloroprene(monomer)

Neoprene(polymer)

87. H_3PO_2 and H_2O

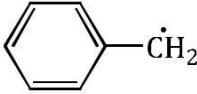
88. The radical  is aromatic because it has 6 p-orbitals and 6 unpaired electrons.

89. III > II > I

90. $-\text{NO}_2$ is a deactivating group, and therefore, nitrobenzene will not undergo Friedel-Crafts reaction.

Biology

91. In oomycetes, the male and female gametes both are non-motile, and the female gamete is large, while the male gamete is small.
92. A museum houses dead remains of animals and plants in the preserved form.
93. *Spirogyra* reproduces by isogamy and produces non-motile gametes. *Volvox* and *Fucus* reproduce by oogamy with the male gamete being motile and the female gamete being non-motile. *Chlamydomonas* reproduces by isogamy, anisogamy and oogamy, and the gametes may be motile or non-motile.
94. Cyanobacteria are found in the coralloid root of the *Cycas* plant.
95. Megasporangium is equivalent to the ovule.
96. Statements A, B and C are correct.
The sporophyte of moss is more elaborate than liverworts, and *Pinus* is a monoecious plant.
97. Among the given list of plants, mustard, brinjal, China rose, chilli, petunia, tomato, Withania, potato, onion, aloe, tulip, lupin, sunhemp, gram and bean have hypogynous flowers.
98. Interfascicular cambium develops from the cells of the medullary rays.
99. China rose belongs to Family Malvaceae; flowers of plants belonging to this family are actinomorphic showing radial symmetry, hypogynous ovary and with twisted aestivation of petals.
100. Lenticels are involved in gaseous exchange between the plant and the surrounding.
101. In plants, one annual ring is formed every year; thus, the number of annual rings tells the age of the tree.
102. Seed coat of coconut is thick.
103. The transition state structure of the substrate formed during an enzymatic reaction is transient and unstable.

- 104.** A phosphoglyceride molecule consists of a saturated or unsaturated fatty acid esterified to a glycerol molecule to which a phosphate group is also attached.

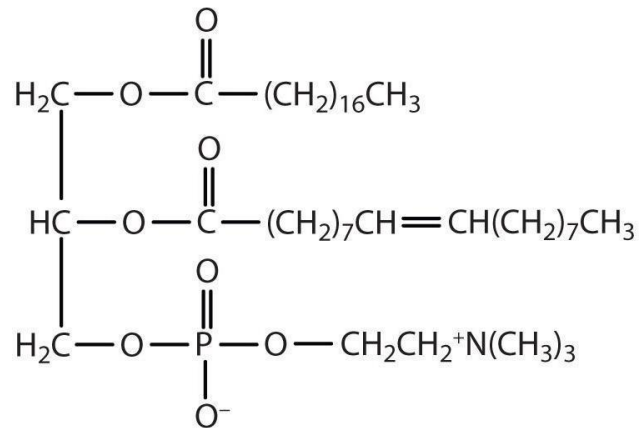

- 105.** In cyanobacteria, chromatophores are the photosynthetic pigments containing membranous extensions.
- 106.** SER is the major site for lipid synthesis.
- 107.** The complex formed by a pair of synapsed homologous chromosomes is known as a bivalent.
- 108.** Arrows 4, 8 and 12 indicate ATP. Pathway A is glycolysis, where ATP is generated at the substrate level, pathway B is Krebs cycle wherein ATP is again generated at the substrate level and ATP is generated through oxidative phosphorylation in ETS which is pathway C.
- 109.** K^+ is the most abundant ion in the intracellular fluid and Na^+ is abundant in the extracellular fluid.
- 110.** Gibberellin functions in breaking seed dormancy by inducing the aleurone cells to secrete enzymes which break stored food in the seed.
- 111.** Facilitated transport is the transport which is mediated with the help of carrier proteins and may be either uphill or downhill.
- 112.** The first stable product of atmospheric nitrogen fixation in the root nodules of leguminous plants by *Rhizobium* is ammonia.
- 113.** Acetyl CoA is the common metabolite to respiration-mediated breakdown of fats, carbohydrates and proteins.

- 114.** Tapetum is the innermost layer of the anther which provides nourishment to developing pollen.
- 115.** Sexual reproduction leads to new genetic combination which leads to variation as it involves mixing of gametes from two different parents.
- 116.** The cells in which meiosis occurs are called meiocytes.
- 117.** Cleistogamous or closed flowers ensure seed setting even in the absence of any pollinators.
- 118.** *Chara* is a monoecious green alga which shows the presence of an upper oogonium and lower antheridium on the same plant.
- 119.** The perisperm is the remains of the nucellus within the seed and is a diploid structure.
- 120.** Tightly linked genes have 0% recombination frequency.
- 121.** If variation in gene frequencies within the population occurs because of chance, then it is termed genetic drift.
- 122.** When I^A and I^B antigens are present together within the RBCs, they both express their own type of sugar on the surface of RBCs. This phenomenon is called codominance.
- 123.** Convergent evolution occurs in the unrelated group of organisms. It is the development of structures with a similar function in an unrelated group of organisms because of similar environmental conditions in which they live.
- 124.** According to the Hardy–Weinberg principle, allele frequency in a population remains stable or constant from generation to generation.
- 125.** Bt cotton is grown by Indian farmers.
- 126.** *Aspergillus niger* is used for the production of citric acid.
- 127.** DNA fragments generated by restriction endonuclease are separated using gel electrophoresis.
- 128.** In algae, the cell wall is made of cellulose, and thus, cellulase is used for its degradation. Methylase is used for the process of methylation.

- 129.** The colonies of recombinant bacteria appear white in contrast to blue colonies of non-recombinant bacteria because of insertional inactivation of alpha-galactosidase in recombinant bacteria.
- 130.** Archaeobacteria flourish in deep sea hydrothermal vents and hot springs where sunlight is scarce. They obtain nutrition through chemosynthesis.
- 131.** The phosphorus cycle is a sedimentary cycle whose main reservoir is rocks.
- 132.** Secondary productivity is the rate of formation of new organic matter by consumers.
- 133.** Shifting cultivation is a type of deforestation and not a conservation strategy.
- 134.** COP (Conference of Parties) occurs before and after the endorsement of the Kyoto Protocol.
CoP-1 – held at Berlin also known as the Berlin Mandate in 1995.
CoP-2 – held at Geneva also known as the Ministerial Declaration.
Cop-3 – held at Kyoto, in 1997, endorsed the Kyoto Protocol.
- 135.** In the plant group, fungi have the highest amount of species diversity.
- 136.** *Petromyzon* is a vertebrate belonging to Cyclostomata which is an ectoparasite on marine fish and turtles.
- 137.** Housefly, butterfly, tsetse fly and silverfish are members of Class Insecta belonging to Phylum Arthropoda.
- 138.** Prawns, scorpions and locusts belong to Phylum Arthropoda.
- 139.** Silverfish belongs to Phylum Arthropoda.
- 140.** In the skeletal muscle, the central gap between actin filaments extending through myosin filaments in the A band is called the H-zone.
- 141.** Cockroach develops from the nymph to the adult form through the process of moulting. The next to last nymphal stage in cockroach shows the presence of wing pads, but only adult cockroaches have wings.
- 142.** The Golgi complex is involved in post-translational modification of proteins and glycosidation of protein and lipid for the formation of glycolipid and glycoprotein, respectively.
- 143.** The rough endoplasmic reticulum is found around the Golgi apparatus and is involved in protein synthesis.

- 144.** Chitin is a polymer of N-acetyl galactosamine and hence is a nitrogen-containing polysaccharide.
- 145.** Coenzymes are enzymes loosely attached to an organic molecule. These organic molecules are generally derivatives of vitamins.
- 146.** The given figure is an illustration of the telophase stage, wherein the nuclear envelope and Golgi complex are reformed.
- 147.** Nutrients (e.g. amino acids and glucose) and electrolytes (e.g. Na^+) are absorbed directly into the blood by active transport.
- 148.** Hypothyroidism in the mother during pregnancy results in defective development and maturation of the growing foetus leading to stunted growth, mental retardation, low IQ and abnormal skin.
- 149.** A – trachea is supported by C-shaped cartilaginous rings.
B – pleural membrane encloses a fluid-filled space and surrounds the lungs.
D – it represents the diaphragm.
- 150.** A – Pulmonary vein takes pure blood from the lungs to the left atria. B
– Dorsal aorta takes blood from the heart to parts of the body.
D – Pulmonary artery takes impure blood from the heart to the lungs.
- 151.** In an ECG, the P wave represents the depolarisation of both atria which leads to their contraction.
- 152.** The adrenal gland is correctly labelled and is concerned with the release of the hormones adrenaline and noradrenaline, collectively known as catecholamine, which stimulate glycogen breakdown during emergency situations.
- 153.** Gouty arthritis is caused by excessive formation of uric acid, and its subsequent deposition in the joints as monosodium salts.
- 154.** The joint between the atlas and the axis is a pivot joint which is an example of a synovial joint. These joints are characterised by the presence of a fluid-filled synovial cavity between the articulating surface of the two bones.
- 155.** A – Receptor
B – Synaptic cleft
C – Synaptic vesicles
D – Ca^{2+}

156. A – Retina

B – Blind spot

C – Aqueous
chamber D – Sclera

157. The adenohypophysis is not directly under neural control; it is under the control of hypothalamic hormones.

Organs in the body such as the gastrointestinal tract, heart, kidneys and liver produce hormones because they contain endocrine cells.

Releasing and inhibitory hormones are produced by the hypothalamus.

158. The thyroid gland synthesises the hormone thyroxine with the help of iodine. Lack of iodine in the diet results in goitre.

159. The correct sequence of spermatogenesis in human males is spermatogonia → spermatocyte → spermatid → spermatozoa.

160. Progesterone functions in maintaining pregnancy. In the absence of progesterone, the endometrium along with blood is shed in the form of menstrual flow.

161. At the time of childbirth, oxytocin is released from the neurohypophysis of the pituitary gland.

162. One of the legal methods of birth control is abortion by taking an appropriate medicine with the prescription of a registered medical practitioner under supervision.

163. Amniocentesis is a test to determine the chromosomal pattern in the amniotic fluid surrounding the developing foetus. Jaundice is not a chromosomal disease and thus cannot be detected by amniocentesis.

164. Introduction of sperms from a healthy donor into the vagina of the female artificially is known as artificial insemination.

165. In co-dominance, the genes from both parents are expressed in the F₁ generation.

166. Haemophilia is a sex-linked recessive disease in which a single clotting factor protein is affected.

167. Thalassaemia is an autosomal recessive disease.

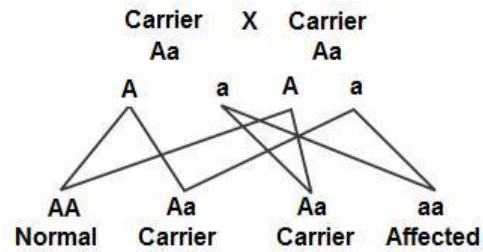

168. A – Transcription

B – Translation C

– Francis Crick

The given schematic represents the central dogma of life.

169. Non-sense mutation is a point mutation which results in a premature stop codon which terminates transcription. Because the non-sense mutation takes place in the *lac Y* gene, all enzymes coded before the *lac Y* gene will be transcribed, and hence, only β -galactosidase will be synthesised.

170. According to Darwinism, competition between two different species is the key factor for organic evolution because it results in divergent evolution.

171. The eyes of octopus and cat are analogous organs because they have a different structure but perform the same function.

172. Infection of *Ascaris* occurs because of the consumption of food and water contaminated with eggs of *Ascaris*.

173. T-lymphocytes are responsible for cell-mediated immunity.

174. An entire collection of plants or seeds having all diverse alleles for all the genes in a given crop plant is known as germplasm collection.

175. During sewage treatment, the biogases produced in the anaerobic sludge digester by anaerobic bacteria include carbon dioxide, hydrogen sulphide and methane.

176. Natality = 250, Immigration = 20, Mortality = 240, Emigration = 30

Therefore, increase in population = [(Natality + Immigration) – (Mortality + Emigration)]

= [(250 + 20) – (240 + 30)]

= 0

- 177.** Fragmentation is one of the steps during decomposition in which detritus is converted to small fragments.
- 178.** The association between sea anemone and hermit crab is symbiosis as both are mutually benefited from the relation.
- 179.** Reducing deforestation and cutting down on the use of fossil fuel will result in the reduction in greenhouse gases such as carbon dioxide.
- 180.** Air (Prevention and Control of Pollution) Act came into existence in 1981.