

WORCESTER POLYTECHNIC INSTITUTE



# Neutron Source Power Supplies

Design and Construction of Power Supplies for a  
Neutron Source to Calibrate Dark Matter  
Experiments

Benjamin Robert Buck, Nelio Garcia Franco Jr.

26 April 2009

A handwritten signature in black ink that reads 'Ben Buck'. The signature is stylized with large, overlapping loops for the letters.

A handwritten signature in black ink that reads 'Nelio Garcia Franco'. The signature is written in a cursive style with a horizontal line underneath.

Advisors:

Professors Hossein Hakim, Peder Pedersen, and Susan Jarvis

## **Authorship Page**

This was written by Benjamin Buck and Nelio Franco in partial fulfillment of the graduation requirements for a Bachelors of Science in Electrical and Computer Engineering at Worcester Polytechnic Institute. The project was completed between August 2008 and April 2009. WPI Professors of Electrical and Computer Engineering Hossein Hakim, Susan Jarvis, and Peder Pedersen served as advisors on this project.

## Acknowledgements

We would like to acknowledge the work which others contributed to the completion of this project: The advisors at Worcester Polytechnic Institute, Professors Hossein Hakim, Susan Jarvis, and Peder Pedersen who guided us and assisted us with the design and report; The sponsor at the Massachusetts Institute of Technology, Professor Joseph Formaggio who donated his time to see the success of this project; Andrew Bazarko and Zilu Zhou from Schlumberger Inc. who provided the Minitron and instructions for testing; The support staff at MIT's Bates Laboratory, Dr. Karen Dow, Ernie Ihloff, Jim Kelsey, Robert Abruzzio, and Chris Vidal who provided technical support, Steven Ciacera who provided manufacturing support, Gerry Fallon, who provided radiation protection support, and Peter Goodwin, who provided support for the pressurized gas used in the experiment. We could not have done this without you!

## Table of Contents

Authorship Page.....	2
Acknowledgements.....	3
Table of Figures.....	6
Table of Tables.....	7
Abstract.....	8
Executive Summary.....	9
Introduction.....	11
Chapter 1: Design Requirements.....	16
Cathode and Filament Power Supplies.....	16
Grid Power Supply.....	19
Microcontroller.....	22
High Voltage Controller Interface.....	24
Chapter 2: Circuit Design.....	26
Cathode and Filament Power Supplies.....	26
Circuit Design.....	26
Power Dissipation Analysis.....	33
Aside.....	35
Grid Power Supply.....	37
Circuit Design.....	37
Power Dissipation Analysis.....	48
Aside.....	50
30kV Controller Interface.....	51
Chapter 3: Testing.....	54
Cathode and Filament Power Supplies.....	54
Output Voltage Ripple.....	54
Thermal Stability.....	55
Grid Power Supply.....	56
Output Voltage Stability.....	57
Output Voltage Ripple.....	58
Thermal Stability.....	58
Switching Transients.....	59

30kV Controller Interface.....	61
Output of the controller.....	61
Output of the supply.....	63
Minitron.....	64
Test Setup.....	65
Testing Results.....	69
Chapter 4: Conclusions and Recommendations .....	72
Conclusions .....	72
Recommendations.....	73
Works Cited.....	76
Appendix A: High Voltage Power Supply Datasheet .....	78
Appendix B: SPICE model for LT1084 regulator .....	79
Appendix C: TIP50 Transistor Data Sheet .....	81
Appendix D: Proposal for Neutron Source.....	85
Appendix E: Minitron Patent (U.S. Patent #5,293,410).....	91
Appendix F: Supertex LR8 Datasheet .....	104

## Table of Figures

FIGURE 1: ESTIMATED DISTRIBUTION OF MATTER AND ENERGY IN THE UNIVERSE [2] .....	11
FIGURE 2: MODEL OF THE MINICLEAN TEST CHAMBER [6].....	13
FIGURE 3: OVERALL LAYOUT OF POWER SUPPLY .....	16
FIGURE 4: 3V REGULATOR BLOCK DIAGRAM.....	17
FIGURE 5: HIGH LEVEL BLOCK DIAGRAM FOR GRID SUPPLY .....	19
FIGURE 6: BLOCK DIAGRAM OF HV SUPPLY CONTROLLER .....	24
FIGURE 7: ORIGINAL DESIGN OF CATHODE / FILAMENT POWER SUPPLY [11].....	27
FIGURE 8: FIRST MULTISIM SCHEMATIC WITH LT1084 .....	28
FIGURE 9: CAPACITOR CHARGE / DISCHARGE DIAGRAM .....	29
FIGURE 10: 3A SIMULATION (YELLOW – INPUT TO REGULATOR, BLUE – OUTPUT OF REGULATOR, 1V/DIV. 2MS/DIV.).....	31
FIGURE 11: 3A SIMULATION WITH 17.107MF (YELLOW – INPUT TO REGULATOR, BLUE – OUTPUT OF REGULATOR, 1V/DIV. 2MS/DIV.) .....	32
FIGURE 12: 3A SIMULATION WITH 39MF (YELLOW – INPUT TO REGULATOR, BLUE – OUTPUT OF REGULATOR, 1V/DIV. 2MS/DIV.) .....	33
FIGURE 13: SCHEMATIC FOR 3A POWER SUPPLY (PARALLEL REGULATOR) .....	34
FIGURE 14: FINAL FILAMENT / CATHODE SUPPLY DESIGN .....	35
FIGURE 15: STANDARD VOLTAGE REGULATOR TOPOLOGY.....	36
FIGURE 16: CURRENT SOURCE TOPOLOGY .....	36
FIGURE 17: HIGH LEVEL VIEW OF GRID POWER SUPPLY .....	37
FIGURE 18: VOLTAGE DOUBLING CAPACITOR / RECTIFIER CONFIGURATION .....	37
FIGURE 19: HIGH VOLTAGE REGULATOR FROM NATIONAL SEMICONDUCTOR [13].....	39
FIGURE 20: MULTISIM MODEL OF GRID POWER SUPPLY (1ST DESIGN) [13] .....	40
FIGURE 21: MODIFIED MULTISIM CIRCUIT WITH SERIES PASS TRANSISTORS.....	42
FIGURE 22: GRID REGULATOR DESIGN WITH LR8.....	43
FIGURE 23: ELECTRONIC SWITCH CIRCUIT.....	45
FIGURE 24: COMMON EMITTER SWITCH SHOWING VOLTAGE DIVIDER OUTPUT .....	45
FIGURE 25: EMITTER FOLLOWER SWITCH SHOWING LARGE $V_{BE}$ .....	46
FIGURE 26: FINAL REGULATOR DESIGN .....	48
FIGURE 27: EMITTER SWITCHING FOR FASTER SWITCH TIMES.....	50
FIGURE 28: 30KV CONTROLLER INTERFACE SCHEMATIC.....	51
FIGURE 29: PHOTOGRAPH OF FIRST CONTROLLER INTERFACE .....	53
FIGURE 30: DA-15 INTERFACE CONNECTOR [20].....	53
FIGURE 31: THERMAL CIRCUIT.....	56
FIGURE 32: THERMAL CIRCUIT.....	59
FIGURE 33: SWITCHING TRANSIENT TURNING OFF. BLUE TRACE – INPUT (1V/DIV), ORANGE TRACE – OUTPUT(50V/DIV) TIME: 250NS/DIV .....	60
FIGURE 34: SWITCHING TRANSIENT TURNING ON. BLUE TRACE – INPUT (1V/DIV), ORANGE TRACE – OUTPUT(50V/DIV) TIME: 250NS/DIV .....	61
FIGURE 35: MINITRON TESTING CHAMBER MODEL FOR RADIATION PROTECTION .....	65
FIGURE 36: TESTING CHAMBER.....	66
FIGURE 37: MINITRON CONNECTED TO FEED-THROUGHS.....	67
FIGURE 38: FINAL SETUP WITH NEUTRON INSULATION IN PLACE .....	68
FIGURE 39: NEUTRON DETECTOR REGISTERING NEUTRON FLUX .....	70

## Table of Tables

TABLE 1: DESIGN REQUIREMENTS SUMMARY FOR 3A SUPPLIES.....	18
TABLE 2: GRID SUPPLY DESIGN REQUIREMENTS SUMMARY.....	21
TABLE 3: DESIGN REQUIREMENTS FOR 30KV CONTROLLER INTERFACE .....	25
TABLE 4: DA-15 CONNECTION LIST .....	52
TABLE 5: RIPPLE TEST RESULTS .....	54
TABLE 6: GRID TEST RESULTS WITH VARYING INPUT VOLTAGE .....	55
TABLE 7: TEST LOADS AND PREDICTED CURRENT AND POWER FOR 200V SUPPLY .....	57
TABLE 8: GRID TESTING RESULTS WITH VARYING LOADS .....	57
TABLE 9: GRID TEST RESULTS WITH VARYING INPUT VOLTAGE .....	58
TABLE 10: PASS CRITERIA FOR 30KV CONTROLLER TESTING .....	62
TABLE 11: TESTING RESULTS FOR 30KV CONTROLLER.....	63
TABLE 12: 30KV SUPPLY OUTPUT TEST RESULTS.....	64
TABLE 13: TEMPERATURE RESULTS AFTER 10 MINUTE TEST .....	69

## Abstract

The purpose of this project was to design and prototype electronics to power and control a compact neutron source. The compact neutron source, or Minitron, was developed by Schlumberger as a tool to be used in looking for oil and other fossil fuels. Physics Professor Joseph Formaggio of MIT intends to use this neutron source as a calibration tool for the Mini-CLEAN (Cryogenic Low Energy Astrophysics with Noble Gases) dark matter research experiment at the Sudbury Neutrino Observatory Laboratories (SNOLab) in Sudbury, Ontario, Canada. Using this neutron source, Physicists can simulate the detection dark matter event. In this way, calibration of the detector can be accomplished, as well as testing of the shielding surrounding the detector. Three power supplies were built. Two were identical supplies for the Cathode and Filament pins on the Minitron which supply up to 3A at 3V. One was a 200V 16mA supply for the Grid pin on the Minitron which is controlled by computer. In addition, a controller for a high voltage supply for the high voltage input on the Minitron. This report documents the process from design requirements to testing the supplies with the Minitron and monitoring neutron generation. At the time of the writing of this report, the Minitron had not yet been used in SNOLAB.



## Executive Summary

Current dark matter research experiments seek to detect and characterize dark matter. Many of these experiments detect events very infrequently. The experiment which this project seeks to assist is the MiniCLEAN (Cryogenic Low Energy Astrophysics with Noble Gases) experiment being constructed at the Sudbury Neutrino Observatory Laboratories (SNOLab) in Sudbury, Ontario, Canada [4]. This experiment detects dark matter by observing photons released from the collision of a particle of dark matter and the nucleus of an Argon atom [6]. In order to ensure that the results are accurate, a method to calibrate the detector is needed.

An event can be simulated using neutrons. By injecting neutrons into the chamber, the detector can measure the recoil of a neutron with the nucleus of an Argon atom. This simulated dark matter event can serve as a method to calibrate the detector. Using a compact neutron source developed by Schlumberger Inc., this project seeks to develop the front end electronics to drive and control this neutron source, or Minitron, so that it can be used to calibrate these experiments [7].

The project details the design of two different power supplies, and one power supply controller which are required to drive the Minitron. There are two identical supplies, which drive the Filament and the Cathode. The Filament is a heating coil which requires a current of approximately 2.5A at a voltage of approximately 2.5V. When the Filament heats up, it releases low pressure deuterium gas into the Minitron. The Cathode requires 2.5A at a voltage of 2.5V as well. The Cathode, along with the Grid supply, sets up an electron beam. The Grid supply is a 200V supply which is able to source up to 16mA. The electron beam which it creates with the Cathode ionizes the deuterium gas. The power supply controller controls a -30kV power supply. This supply accelerates the ionized deuterium gas towards a target impregnated with deuterium. This creates a fusion which creates helium-3 and a free neutron [7].

The design is documented from design requirements, design iteration, final design, and testing. Finally, the supplies are attached to the Minitron, and neutron generation is observed. All of the design requirements were exceeded, and when connected to the Minitron, predictable results were observed. After the completion of the testing, recommendations are given for moving forward with this project to a production level product.

## Introduction

Since the mid 1930s the world has been fascinated by the idea of an “invisible” matter known today as dark matter. In 1933, Dr. Fritz Zwicky observed that some orbiting masses in space were orbiting with a velocity far faster than could be explained by the observed mass. This led to the proposal of a “missing mass”, today known as dark matter [1]. After over 70 years, dark matter research is still alive. Due to dark matter’s lack of electromagnetic interaction, physicists and astronomers have been trying to develop methods to detect this dark matter which is theorized to make up approximately 23% of the total mass of the universe as shown in Figure 1 [2].

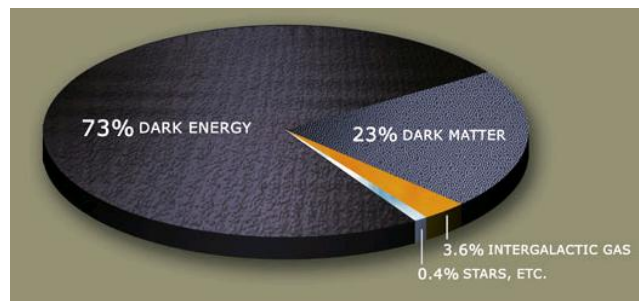

Figure 1: Estimated Distribution of Matter and Energy in the Universe [2]

There have been several experiments claiming positive evidence for dark matter detection, but they have not yet been confirmed [3]. Currently, colleges and laboratories around the world have been on the look for traces of the elusive dark matter [4]. Many experiments which look to characterize dark matter record interactions very infrequently. Because of this, a need to calibrate these experiments is heightened. It has been proposed by physics professor, Dr. Joseph Formaggio, and others to use neutrons to simulate a dark matter interaction as to provide a means to calibrate this experiment. For this to be done, a neutron source would need to be obtained.

The neutron source, known as the Minitron, was generously lent to Dr. Joseph Formaggio by Schlumberger Incorporated (SLB), a leading oil services provider, who has used the Minitron in detecting the presence of oil. Schlumberger, who have Research and Development facilities in a variety of

locations around the world, was founded in 1927 by two brothers who realized new methods of obtaining geological information using electromagnetic systems to create images of the wells. Today, with principle offices in Houston, Paris and The Hague, Schlumberger continues to improve production and create new innovative ways to aid the oil and gas industry [5].

The new approach being taken in this project is in the usage of the Minitron. The Minitron is used to supply neutron flux. The neutrons produced will be projected into a container of liquid argon, which will expel a photon once the neutron collides with the nucleus of the argon (see Appendix D). The container of liquid argon will be precisely measured and calibrated in order to compare the results of neutron collision with that of possible dark matter collision. The liquid argon will then be placed underground and will serve as a target to the dark matter. If the assumption that the physical properties of dark matter are similar to those of a neutron is correct, the collision will produce photons similar to the neutron collision. The measurements taken from the dark matter collision will then be compared to the measurements obtained from the Minitron calibrations in hopes of attaining numerical data on dark matter.

The experiment proposed by Dr. Formaggio will target the majority of astronomy/physics professors and scientists who are currently studying or have an interest in the study of dark matter. This project is being designed not only to support the ongoing dark matter experiments currently held worldwide, but also in hopes of serving future dark matter projects. It will be first used in the MiniCLEAN (Cryogenic Low Energy Astrophysics with Noble Gases) experiment being constructed at the Sudbury Neutrino Observatory Laboratories (SNOLab) in Sudbury, Ontario, Canada. MiniCLEAN looks for dark matter by recording the recoil of a Argon nucleus when a particle of dark matter collides with it [6]. Figure 2 shows the model of the MiniCLEAN test chamber.

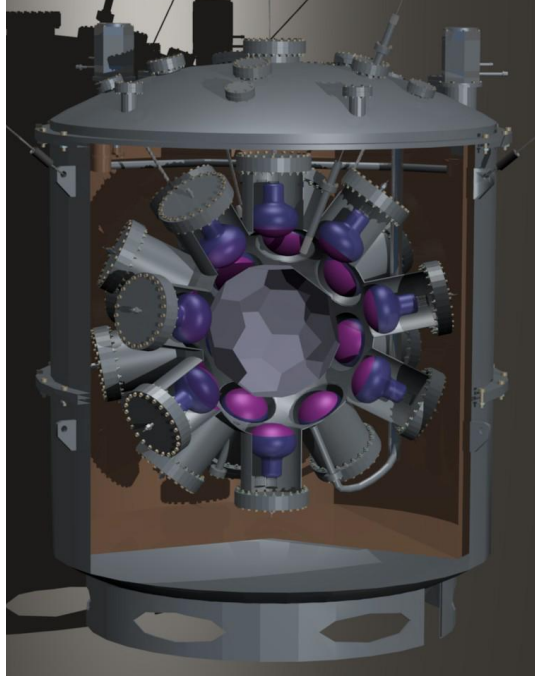

Figure 2: Model of the MINICLEAN test chamber [6]

The basis of neutron production is through a Deuterium to Deuterium (D-D) reaction. Deuterium is a stable, nonradioactive isotope of hydrogen, also known as heavy hydrogen, containing one proton and one neutron. When the two deuterium atoms collide, helium-3, a helium isotope containing two protons and one neutron, is created as well as one free neutron. More information on the D-D reaction is located in Appendix D. By understanding how the neutrons are produced with the Minitron, the information on the power supplies needed for each part of the source can be easily contemplated.

In order to guarantee that the Minitron works as desired by the user, certain specifications needed to be met. Andrew Bazarko of Schlumberger gave a short detailed explanation of a few suggested inputs for each of the pins located on the Minitron.

**Grid Voltage** – The Grid voltage will require 200V nominally. This power is used to attract the electrons towards the Grid which in turn will ionize the deuterium in preparations for the collision between deuterium atoms.

**Cathode** – The Cathode, which will be supplied with 2.5A of current nominally, will serve as a fountain of electrons to be used in conjunction with the Grid. The electron beam produced will be used to ionize the deuterium supplied by the Filament.

**Filament** – The Filament, which will be supplied with -2.5A of current nominally, is a source of deuterium that will be used alongside the Cathode and Grid in order to create ionized deuterium. The ionized deuterium will be projected towards a deuterium impregnated target with the assistance of the corona shield's power supply.

**Corona Shield** – The corona shield, which is located on the target end of the Minitron, will be supplied with -30kV in order to function properly for this experiment. The -30kV will be used to attract the ionized deuterium towards the deuterium impregnated target, causing a Deuterium to Deuterium reaction.

More information on all of the pieces of the Minitron can be found in Appendix E.

In the following sections and subsections of this report, the reader will encounter the detailed requirements of each of the power supplies needed in this project. The sections following the requirements will consist of actual circuit designs that were proposed, modified and ultimately implemented on the path toward building the power supplies. The final sections will describe the testing procedures used to ensure individual component functionality as well as neutron generation when the supplies are connected to the Minitron.

With the background of the project explained thoroughly, the reader should now be fully informed and capable of understanding more about the requirements of the power supplies and the process used to create each supply.

## Chapter 1: Design Requirements

Before describing the design of each of the supplies, it is important that the design requirements are laid out in full. These requirements will serve as a reference as to whether the project was successful or unsuccessful, and will guide the rest of the design phase. There will be three major components. A 30kV HV power supply controller, a 200V Grid power supply, and two 3A power supplies for the Cathode and Filament.

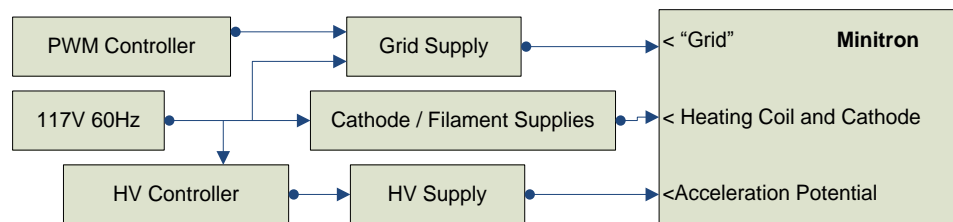

Figure 3: Overall Layout of Power Supply

Figure 3 shows how the main components of the project will interact. The Grid supply will be able to deliver 16mA of current at 200V and will be controlled by a pulse width modulator to output a 200V peak square wave at approximately 1kHz. The Cathode and Filament supplies will be able to source 3A of current each. At this current, the estimated voltage is 3V. The HV controller will interact with the 30kV supply to output -30kV on the order of 10 $\mu$ A. Each of these major components is described in more detail below, as well as some errata which do not specifically fit into either category.

### Cathode and Filament Power Supplies

There are two high-current power supplies which are connected to the Minitron. Each of them powers a heating element with a resistive load. These heating elements release the deuterium ions which can then be accelerated to produce the D-D reaction (see appendix D) [7]. The two supplies will be identical in the final project as they have the same requirements.

According to the specifications given by Andrew Bazarko of Schlumberger Inc. (SLB inc), the load in the Minitron can be modeled as a resistive load at approximately 1 $\Omega$ . Unlike the 200V supply, the load will be constant and will always be connected to the supply.



Figure 4 below shows a high level block diagram of the Cathode and Filament supplies.

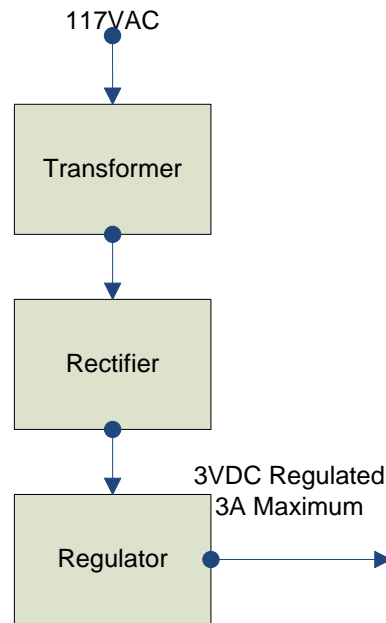

Figure 4: 3V Regulator Block Diagram

The input to the supply will be standard wall power, 117VAC. This is the most convenient form of power available and it will be used exclusively throughout this design. For the intentions of this project, standard wall power is defined at 117V RMS  $\pm$  5% 60Hz AC power. The output of the supply will be at 3V. The heating coils, which will be attached to this output, will draw approximately 3A of power at this voltage. The supply will maintain this output voltage to within 10% while loaded. The ripple on the output line will be within 3%. A summary of the specifications is shown in Table 1.

The efficiency of the power supply is an important aspect that must also be considered. It is likely that a linear power supply will be used to reduce the amount of Electro-Magnetic Interference, also known as EMI. Switching power supplies use high speed current switching onto a capacitor in order to maintain a voltage. This switching, however, can produce EMI [8]. Linear supplies, which generally do not produce any significant EMI, maintain a voltage by using an active component to reduce the input voltage to the output voltage [9]. A sensing mechanism controls how much voltage is dropped by the active

component, thus maintaining the output voltage. The active component, however, dissipates the power loss into heat. For this reason, linear supplies are known for being less efficient than their switching counter-parts [8]. The efficiency is not specified; however design decisions will be made to make the supply as efficient as possible. Also, since linear supplies convert excess power to heat, it is likely that thermal issues will need to be considered in the design phase. The experiment in which this project will be used uses photomultiplier tubes, or PMTs, to detect a dark matter event. These PMTs are sensitive to EMI [10]. If a switching design is selected, the spectral overlap of the interference generated and the sensitivity of the PMT will need to be analyzed.

Another design consideration that needs to be addressed is the ambient temperature. The supply will be used underground where the ambient temperature is 25°C. However, the lab is climate controlled to 20°C. All the power sources will need to be able to operate at these temperatures.

Table 1 below shows the summary of the design requirements for this power supply.

<b>Property</b>	<b>Requirement</b>
Output Voltage	3V $\pm$ 10%
Maximum Output Current	3A
Output Ripple	<3%
Input Voltage	117V $\pm$ 5% 60Hz
Operating Temperature	20°C - 25°C

**Table 1: Design Requirements Summary for 3A supplies**

## Grid Power Supply

The Grid Power Supply acts as the trigger of the Minitron [7], causing electrons to collide with deuterium, creating ions to be accelerated by the -30kV potential. In order to control the neutron flux, the Grid power supply will be pulse-width modulated at frequencies up to 1kHz. Using a microcontroller to modify the duty cycle and frequency the supply will be able to control the neutron flux. Figure 5 below shows the high level block diagram for this circuit.

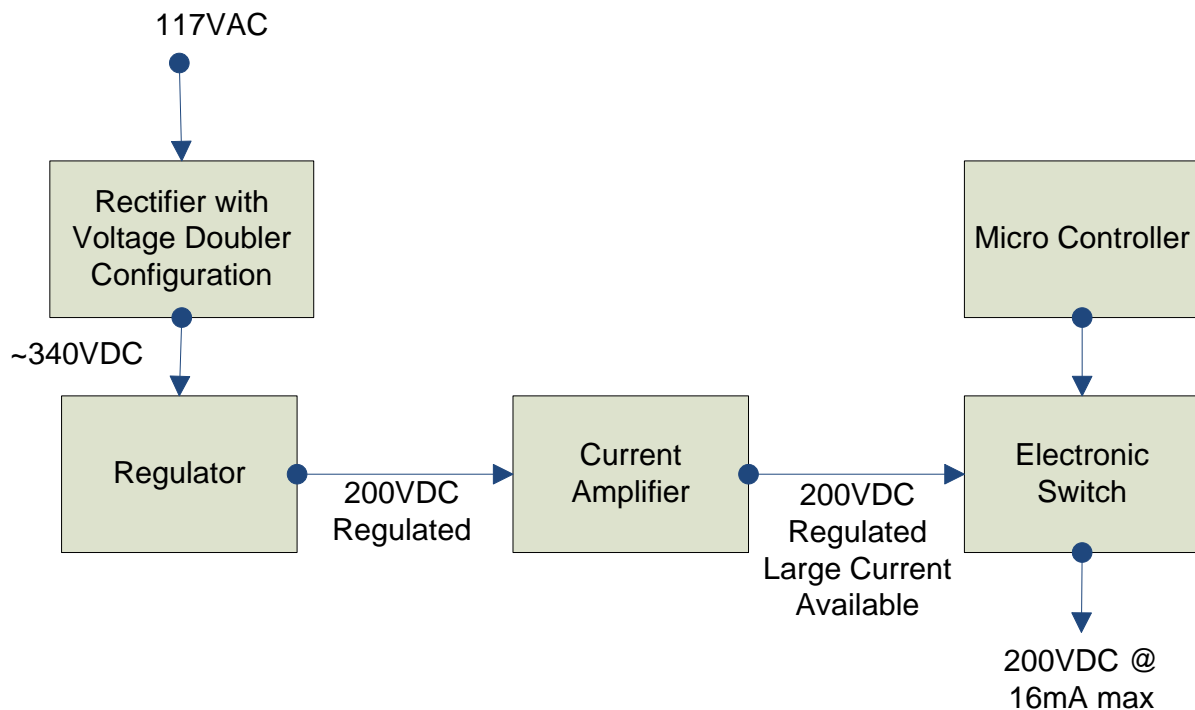

Figure 5: High Level Block Diagram for Grid Supply

The input to the Grid supply will be 117VAC. This is selected for the same reasons as in the Cathode and Filament supplies, namely that it is the most convenient form of power available. Similar to the 3V supplies, this supply must be able to tolerate a change in supply voltage of 5%.

The specification for the Grid supply given by Andrew Bazarko of SLB inc. was for an output of 200V at approximately 10mA. However, during the operation of the Minitron, several other factors affect the current drawn by the Grid. In normal operation, currents of up to 16mA may be drawn. For this reason,

the output will be tested to 16mA output current to provide design margin and flexibility. Depending on the needs of the physicists during neutron characterization, the output current may be raised or lowered. With a nominal output of 200VDC at 10mA, the load will be modeled as a 20k $\Omega$  resistive load. This power supply will be switched on and off to control the neutron flux, so the rise time must also be specified. The specified maximum switching frequency will be 1kHz. The minimum duty cycle specified is 10% which corresponds to an on time of 100 $\mu$ S. The maximum allowable rise or fall time specified will be 10% of the minimum on time, 10 $\mu$ s. In addition, the regulation for this power supply while switching is an important requirement. The change in voltage from full load to no load will be less than 3%. In addition, the maximum ripple allowable on the output pin must be 1% on the line, excepting switching transients. These specifications are in place to ensure that the output of the 200V power supply will be able to provide adequate power to the Grid pin on the Minitron (see Table 2).

The Grid supply, like the Cathode and Filament supplies, must not produce EMI and must function at the ambient temperature in the mine. The minimum efficiency for this supply is not specified; however design decisions will be made to keep the supply as efficient as possible. Since it is likely that a linear power supply will be utilized in order to eliminate EMI, the power dissipated in the supply will be converted to heat, which will need to be addressed during the design phase.

The output of the Grid supply will not go directly to the Minitron. It must pass through an electric switch, controlled by the microcontroller so that the frequency and duty cycle can be modified. An opto-coupler or transistor will likely be used to isolate the sensitive electronics in the microcontroller from the high voltages and currents on the power supply side. The switch will drive a high-voltage transistor to be in either cutoff or saturation to switch the output voltage off or on, respectively.

Table 2 below shows a summary of the design requirements for the Grid supply.

<b>Property</b>	<b>Requirement</b>
Output Voltage	200V $\pm$ 3%
Maximum Output Current	16mA
Output Ripple	<3%
Input Voltage	117V $\pm$ 5% 60Hz
Switching Rise Time	<10 $\mu$ S
Switching Fall Time	<10 $\mu$ S
Operating Temperature	20°C - 25°C

Table 2: Grid supply Design Requirements Summary

## Microcontroller

The microcontroller will control the pulsing of the Grid supply output. The microcontroller will be able to pulse at frequencies ranging from 100Hz to 1kHz. The smallest increment in the period will be 1 mS. Additionally, the duty cycle of the supply will need to be controlled. The duty cycle will range from 10% to 100% as desired by the user.

The microcontroller will accept input from the user via a serial port connection. The serial port connection will accept several commands from the user as follows:

**Change Period:** This command will take an argument of a three digit integer. This integer, when multiplied by 1 mS, will constitute the period of the device. This will change the frequency of the pulse width modulator to the specified frequency if and only if the frequency is above 100Hz and below 1kHz, the desired frequency range specified by Professor Formaggio.

**Change Duty Cycle:** This command will take an argument of a three digit integer. This integer will represent the duty cycle. For example, if the argument is 40, the duty cycle will be set to 40% (on 40% of the time, off the other 60%). This will change the duty cycle if and only if the duty cycle is between 10 and 100, the range between specified by Professor Formaggio is between 10% and 100%.

**Echo:** This command will write the current configuration back to the computer. Specifically, it will display the duty cycle, frequency, and state of the output. This command was not requested specifically, however the designers assumed that this functionality was desired.

**Enable Output:** This command will enable the output. If the output is already enabled, this command will have no effect. This command was also not requested, however the designers assumed that this functionality was desired, especially since this will be controlling the output of radiation.

**Disable Output:** This command will disable the output. If the output is already disabled, this command will have no effect. This command was also not requested; however the designers assumed that this functionality was desired, especially since this will be controlling the output of radiation.

**DC Mode:** This command will instantly put the output of the Grid supply in DC output mode. This special command was requested by Professor Formaggio. With this command, the user can switch quickly between a desired pulsing frequency and duty cycle to DC mode by entering a single command. This will be useful while characterizing the neutron flux.

## High Voltage Controller Interface

The HV power supply provides the potential needed to extract the neutrons from the source. This large potential is used to accelerate deuterium ions so that the D-D reactions can take to produce neutrons [7]. The original plan was to design a -30kV power supply to use with the Minitron. The supply had requirements of a -30kV output voltage delivering 50 $\mu$ A of output current. Unfortunately, when simulations and analysis of basic designs for this supply were completed, the results indicated that purchasing expensive high voltage diodes would be required. Because of this, the design requirement was changed to develop the controller interface to a 30kV supply, which MIT already owns. Figure 6 below shows the block diagram for this supply.

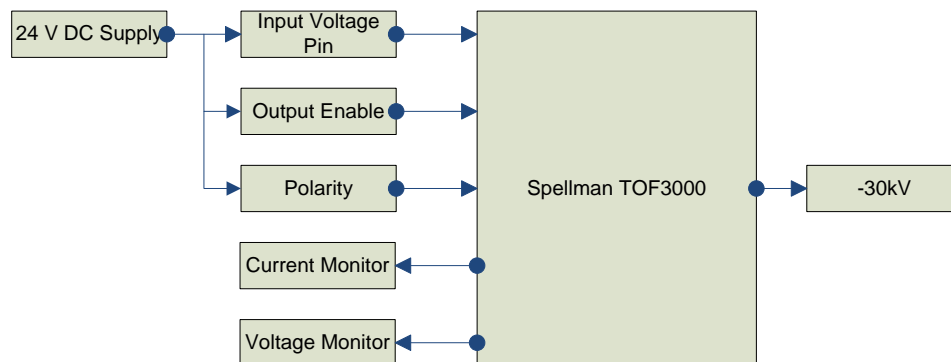

Figure 6: Block Diagram of HV Supply Controller

The supply (Spellman TOF3000, see Appendix A) requires an input controller to supply input control signals which determine the output voltage. The supply requires an input of +24V DC and input current of 2A maximum. The polarity of the output voltage can either be positive or negative, which for this project is desired to be negative. The polarity is selected by a TTL input pin. The output voltage is controlled by a voltage program pin. The voltage program input can vary from 0 to +10V DC which corresponds to varying the output for the supply from 0 to +/- 30kV output. For example, if the user decides there should be an output voltage of 15kV, then the voltage applied to the program input should be at 5V DC. In addition there is an interlock which enables or disables the output of the device.



For this project, an output voltage of -30kV is desired. The controller will have the following design requirements listed in Table 3.

<b>Property</b>	<b>Requirement</b>
Voltage Control - Output Voltage	10V $\pm$ 10%
Voltage Feedback Pin	Easily Accessable
Current Feedback Pin	Easily Accessable
TTL HV Enable Pin	<0.3V when On, >4.5V when Off
TTL HV Polarity Pin	<0.3V (corresponds to negative output)
Input Supply	24V $\pm$ 2% at up to 2A
Operating Temperature	20°C to 25°C

**Table 3: Design Requirements for 30kV controller interface**

The Voltage Feedback and Current Feedback pin will need to be easily accessible for testing. These pins output a voltage which corresponds to the output voltage or output current. The input pins, Voltage Control, TTL HV Enable and TTL HV Polarity, have an input impedance of  $> 1M\Omega$ , so the current drawn is negligible. A 24V DC power source is already supplied and will power the controller board as well. It may vary by no more than 2%.

## Chapter 2: Circuit Design

In this section the designs of the various components of the project are described. This includes the development of various designs, as well as designs which were attempted or abandoned.

### Cathode and Filament Power Supplies

The Minitron requires two 3A power supplies to drive heating elements. During the design period for the Cathode and Filament power supplies, many different ideas and modifications were made in order to meet the design goals.

#### Circuit Design

Early in the design process the decision was made to design the Cathode and Filament power supplies, as well as the Grid power supply, as a linear power supply over a switching power supply. The main advantage of the switching power supply is the power efficiency. Unfortunately switching power supplies can produce EMI [9]. The potential interference caused by the switching power supply could affect the sensitive PMTs used in proximity to the Minitron. Since this supply, once proved functional, may be used in other experiments, the amount of interference generated was of great concern to the customer. Power efficiency, however, was not. Therefore, the linear power supply was a reasonable design choice. Although the efficiency of linear power supplies is generally much lower than their switching counterparts, the linear power supply will not produce any high-frequency interference [9].

Following the high level block diagram in Figure 4, a simple design included the transformer, rectifier, and regulator. This original design of the Cathode / Filament supply can be seen in Figure 7 [11].

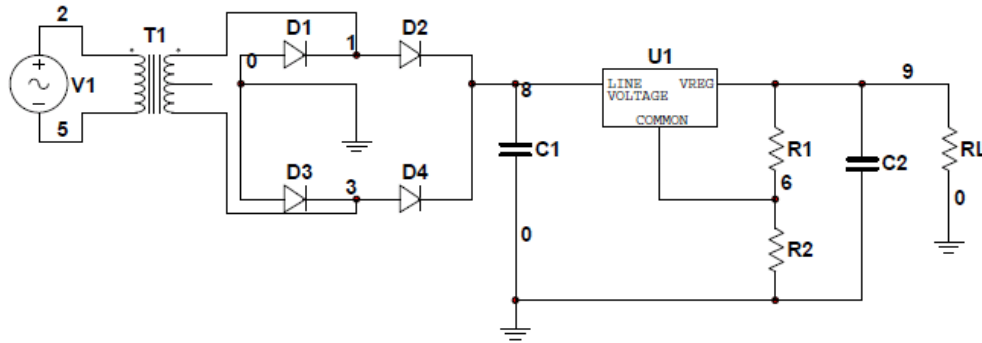

Figure 7: Original Design of Cathode / Filament Power Supply [11]

The transformer T1 will drop the input voltage down to a lower voltage. The fully wave rectifier and capacitor (C1) combination then produce an unregulated DC voltage with some ripple. The regulator U1 would drop this voltage down to exactly 3V DC with very little ripple. The resistors R1 and R2 program what voltage the regulator will output. The result would be a constant 3V being supplied through the load in the Minitron shown as RL. The second capacitor, C2, is needed by the regulator to ensure output stability.

An initial prototype of this design was constructed using an AP1084 low voltage regulator. The transformer used was a 20:1 transformer, which dropped the input voltage to approximately 6 VRMS after rectification. The resistor values were determined by the equation given on the data sheet [12]:

$$V_{\text{out}} = 1.25V * \left(1 + \frac{R_2}{R_1}\right)$$

With  $R_2 = 121\Omega$ ,  $R_3$  was found to be  $169\Omega$ . A trim pot was used to select this precise value. The input capacitance, C1, was chosen to be  $10\mu\text{F}$  as suggested by the data sheet in order to maintain stability. Similarly, the output capacitance was chosen to be  $10\mu\text{F}$  as well.

However, an incorrect assumption was made in the selection of C1. While choosing C1, the designers incorrectly assumed that 10 $\mu$ F would be able to store enough charge to maintain approximately 6V DC on the input of the regulator. The capacitor size was actually off by several orders of magnitude. This resulted in a rectified sinusoid being fed into the regulator. Because of this, the condition the  $V_{in} = V_{out} + >1.4V$  required by the AP1084 was not met. Therefore, when initial testing was conducted, the regulator failed. The conclusion drawn from this failure was that the voltage at the output of the regulator had achieved a level higher than the input of the regulator therefore causing the current to reverse its direction.

In order to successfully design the 3V power supply, proper calculations and simulations would have to be done. Unfortunately, while modeling the design in MultiSim the model for the desired 3V regulator, the AP1084, could not be encountered online. The LT1084 is very similar to the AP1084 and was used in place of the actual regulator for the simulations. The SPICE model for the LT1084 can be found in Appendix B. Figure 8 shows the resulting schematic for the second attempt at the Cathode and Filament power supplies.

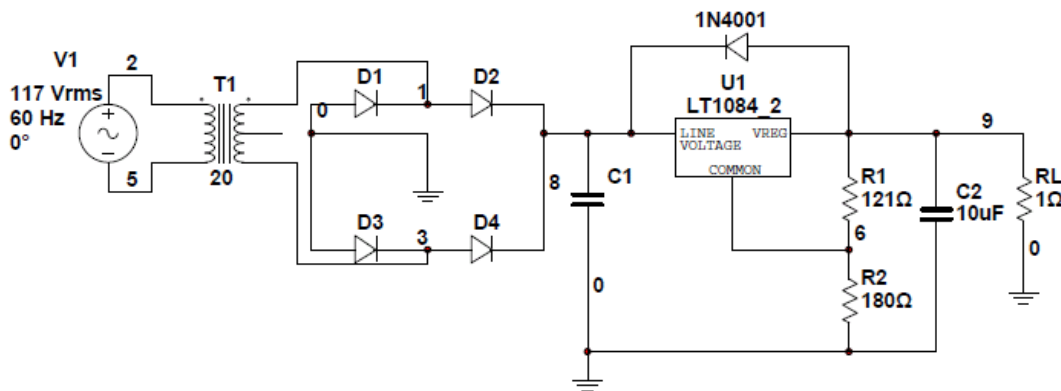

Figure 8: First Multisim Schematic with LT1084

Note that a protective diode is placed across nodes 8 and 9 to ensure that large amounts of current cannot flow in reverse through the regulator. Since the voltage at the input to the regulator U1 will be at approximately 6V RMS, the capacitor C1 will need to be a large value for the circuit to function without the input voltage dropping below the necessary 4.4V. Figure 9 below shows the charging and discharging cycle of the capacitor C1.

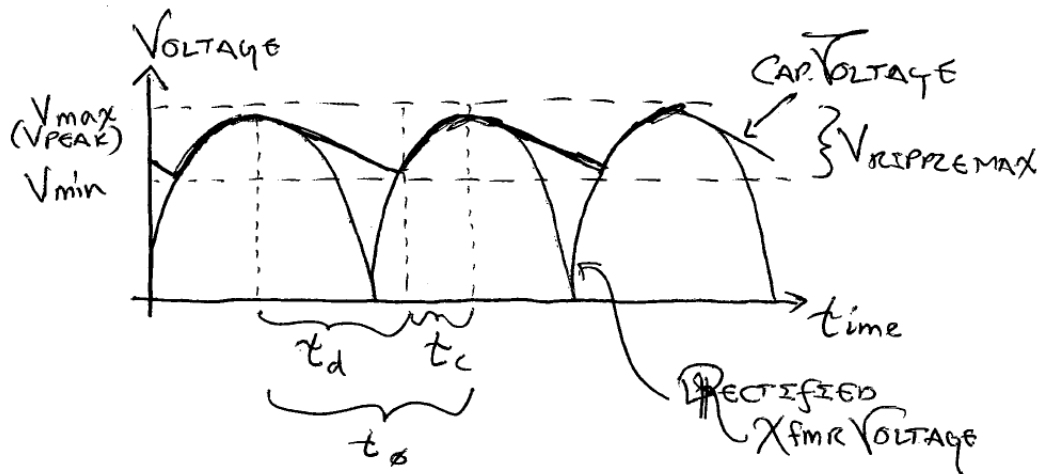

Figure 9: Capacitor Charge / Discharge Diagram

When the capacitor is discharging during  $t_d$  the voltage is given by:

$$V_C = \frac{Q_{\text{peak}}}{C}$$

Assuming a constant current of 3A:

$$\frac{dQ}{dt} = I = 3A$$

Now, taking the derivative of the capacitor voltage:

$$\frac{dV_C(t)}{dt} = \frac{1}{C} * \frac{dQ}{dt}$$

Substituting, one finds:

$$\frac{dV_C(t)}{dt} = \frac{1}{C} * I$$

Now, integrating:

$$V_C(t) = V_{\text{peak}} + \int_{t_0}^{t_d} \frac{1}{C} * I * dt$$

During the charging cycle, the capacitor voltage follows the rectified transformer voltage:

$$V_C(t) = V_{\text{peak}} * \cos(2 * \pi * 60\text{Hz} * t)$$

It is desired to determine the smallest capacitor value which will be able to store enough charge to keep the capacitor voltage above 4.4V. To do this, the capacitor charging time,  $t_c$ , is first found. With  $V_{\text{peak}} = 7\text{V}$ :

$$4.4\text{V} = 7\text{V} * \cos(2 * \pi * 60\text{Hz} * t_c)$$

$$\frac{4.4\text{V}}{7\text{V}} = \cos(2 * \pi * 60\text{Hz} * t_c)$$

$$\cos^{-1}\left(\frac{4.4\text{V}}{7\text{V}}\right) = 2 * \pi * 60\text{Hz} * t_c$$

$$t_c = \frac{\cos^{-1}\left(\frac{4.4\text{V}}{7\text{V}}\right)}{2 * \pi * 60\text{Hz}} = 2.364\text{mS}$$

Now, solve the discharging equation, assuming  $I = 3\text{A}$ . Solve for  $V_C = 4.4\text{V}$ . Since this is a rectified sinusoidal voltage, to find  $t_d$  the charging time is subtracted from half of the period.

$$4.4\text{V} = 7\text{V} + \int_0^{5.9696\text{mS}} \frac{1}{C} * (-3\text{A}) * dt$$

Moving constants out of the integral:

$$\frac{(4.4V - 7V) * C}{-3A} = \int_0^{5.9696mS} dt$$

Evaluating the integral:

$$\frac{(4.4V - 7V) * C}{-3A} = 5.9696mS$$

Solving for C:

$$C = 5.9696mS * \frac{-3A}{(4.4V - 7V)} = 6.88mF$$

Evaluating this equation gives  $C = 6.88mF$ . The simulation results below show the circuit using  $C1 = 6.88mF$ .

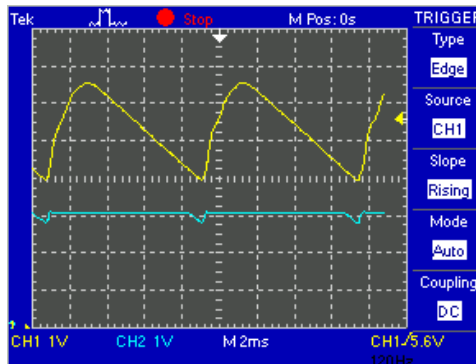

Figure 10: 3A Simulation (Yellow – Input to Regulator, Blue – Output of Regulator, 1V/div. 2ms/div.)

Note that in the simulation the input voltage drops slightly below the threshold and the output voltage follows. This simulation, however, does not take into consideration the ohmic losses in the transformer. Even a small DC resistance in the transformer will mean significant losses while drawing 3A of current. The transformer had a measured output impedance of  $0.15\Omega$ . At 3A, this gives an approximate DC drop of the peak voltage of 450mV. In reality, this voltage drop is larger. Current is only drawn while the transformer is charging the capacitor which is only a fraction of the time. For this reason, the transformer supplies much more than 3A of current in order to put enough charge into the capacitor.

This results in a higher voltage drop. From calculations, the transformer is charging the capacitor about 28.3% of the time. The peak current will therefore be assumed to be 10.5A, giving a voltage drop of 1.8V. This gives a peak capacitor voltage of 5.2V. First, the charging time needs to be re-evaluated:

$$t_c = \frac{\cos^{-1}\left(\frac{4.4V}{5.2V}\right)}{2 * \pi * 60Hz} = 1.491mS$$

Re-evaluating for the capacitor size yields:

$$C = 6.842mS * \frac{-3A}{(4.4V - 5.2V)} = 17.106mF$$

However, having the input-output voltage differential go to exactly 1.4V is very risky because it does not provide any design margin. For this reason, larger capacitor was chosen. A 39mF capacitor was a readily available value for C1 in the final design. Including such a large value of C1 in the design will prevent circuit failure due to component tolerances. Figure 11 below shows the simulation with the 17.107mF capacitor while Figure 12 below shows the simulation with the 39mF capacitor. Note the larger voltage margin available with the 39mF capacitor as compared to the 17.107mF capacitor. Including this in the design will prevent circuit failure due to varying input voltage.

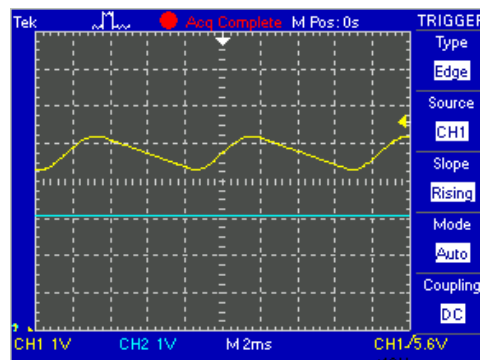

Figure 11: 3A Simulation with 17.107mF (Yellow – Input to Regulator, Blue – Output of Regulator, 1V/div. 2ms/div.)



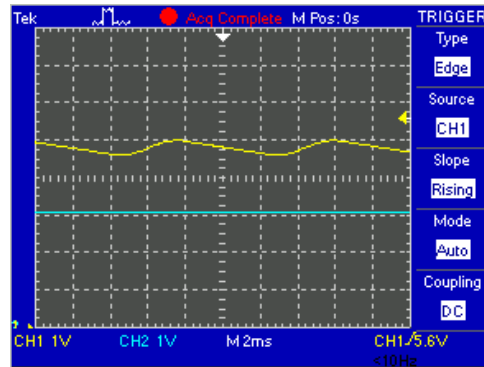

Figure 12: 3A Simulation with 39mF (Yellow – Input to Regulator, Blue – Output of Regulator, 1V/div. 2ms/div.)

### Power Dissipation Analysis

To calculate the power dissipated in the power supply, the RMS voltage will be approximated by the arithmetic mean of the maximum and minimum voltages. At maximum, there is a 2.2V drop across the regulator. At minimum, there is a 1.4V drop across the regulator. The mean is 1.8V across the regulator. At 3A the power dissipation is 5.4W.

One idea for lowering the amount of power being dissipated over the 3V regulator was the use of an alternative transformer that would drop the voltage lower than the previous 6V. A 24:1 transformer was found which would bring the RMS voltage down to 5V. This transformer would not function, however, because of the ohmic losses. Because the RMS voltage was lower, less ripple could be tolerated. Because less ripple could be tolerated, a larger input capacitance would be needed. This, in turn caused more current to be drawn while the capacitor was being charged. With the ohmic losses from the increased current drawn from the transformer, the voltage drop in the transformer became unacceptable.

An alternative approach seeks to not reduce the amount of power dissipated, but spread the thermal load into multiple devices. Placing two regulators in parallel will split the load of both of the regulators in half. Theoretically, changing nothing in the circuit except for the addition of the regulator will result in the same output with a distributed thermal load. The schematic created using simulations can be seen in Figure 13.

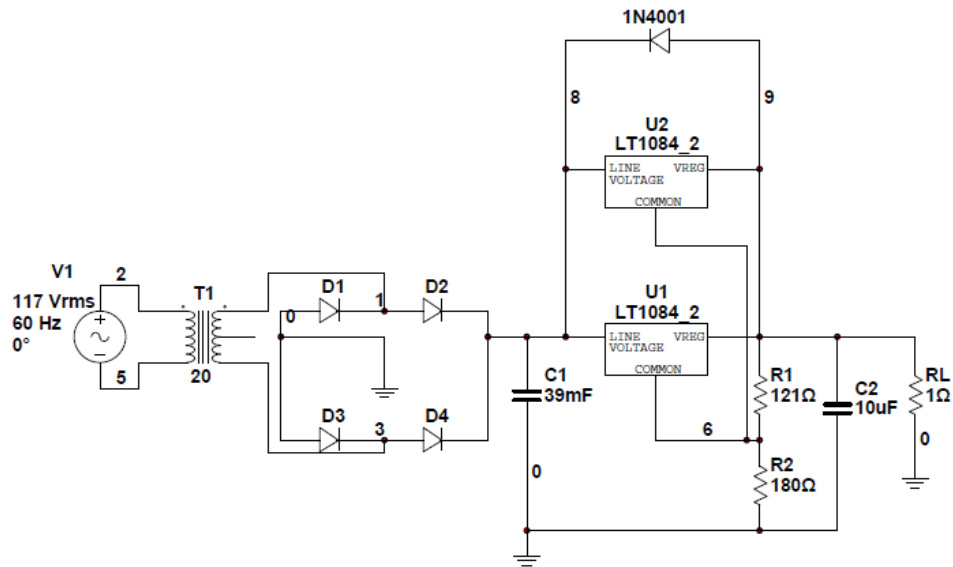

Figure 13: Schematic for 3A Power Supply (Parallel Regulator)

As can be seen in the schematic above, the resistor configuration used in the previous design has also been used in the parallel regulator design. By doing so, this will allow the regulators to output the correct voltage and half the total output current. However, in practice the regulators are not both identical. Due to slight differences in the construction of each individual regulator, the regulators cannot be expected to be perfectly matched. This will cause one to output a slightly higher voltage than the other, resulting in a larger amount of current sourced by that regulator. This will result in one regulator dissipating significantly more power than the other. The datasheet specifies a maximum load regulation of 1% [12]. An approximation of the output resistance of the regulator is  $100\text{m}\Omega$  from observations while testing the device. This results in a change in current of  $300\text{mA}$ , or 10%. This is far too high. Ballast resistors could be used to change prevent this load mismatch, however this would decrease the efficiency of the supply [12]. For this reason, this technique was abandoned.

The power efficiency of these supplies is important. From above, with a  $1\Omega$  load at  $3\text{A}$  output current, the regulator dissipates  $5.4\text{W}$  of power. Delivering  $3\text{A}$  to  $1\Omega$  dissipates  $9\text{W}$  of power. Finding power efficiency:

$$\text{Efficiency} = \frac{P_{\text{delivered}}}{P_{\text{dissipated}} + P_{\text{delivered}}} * 100\%$$

$$\text{Efficiency} = \frac{9\text{W}}{5.4\text{W} + 9\text{W}} * 100\% = 62.5\%$$

This is an acceptable level of efficiency.

While prototyping with these supplies, the designers noticed that it is very convenient to use a potentiometer in the voltage divider (R2 in Figure 14 below). This allows the user to fine tune the output current. The final design for the Cathode and Filament power supplies is shown below in Figure 14.

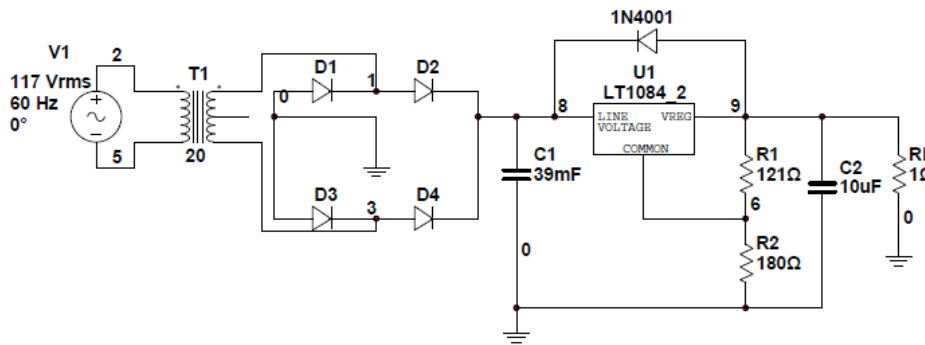

Figure 14: Final Filament / Cathode Supply Design

### Aside

After completing testing with the Minitron, it was considered that the regulators might be best used in a current regulation setup. In the most common usage, a voltage regulator is set up as in Figure 15 below.

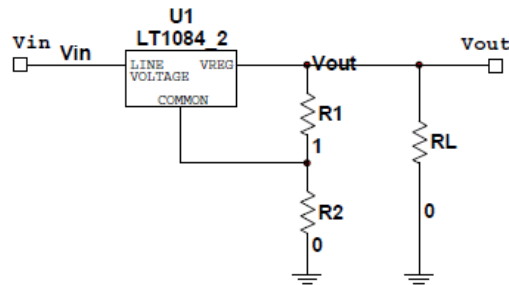

Figure 15: Standard Voltage Regulator Topology

The regulator functions by maintaining a reference voltage across R1. However, if R1 is placed in series with the load, the regulator can act as a constant current source. A regulator should be chosen which has a low reference voltage to ensure that large amounts of power are not dissipated in R1.

Alternatively, using an amplifier, a very small R1 could be chosen, and the voltage across it amplified.

This is shown in Figure 16 below.

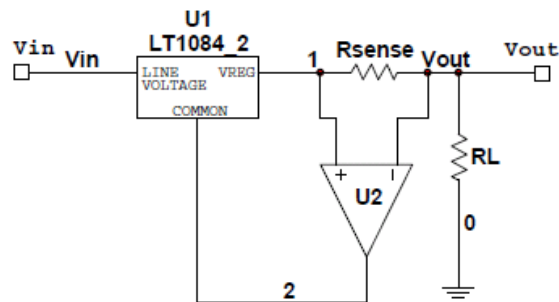

Figure 16: Current Source Topology

The current can be controlled by adjusting the gain of the amplifier U2. Making this change will allow the user to more easily select the Cathode and Filament currents.

## Grid Power Supply

The Grid power supply is the more complex supply in the project. Not only does it require a very precise voltage output, but in addition, the supply must be controlled by an electronic switch. As previously discussed, a linear power supply design was selected for this supply.

### Circuit Design

As shown in Figure 17 below, there are three main stages of the high level design of the power supply.



Figure 17: High Level View of Grid Power Supply

The first step in the high level design for the power supply is to rectify 117VAC using bridge rectifier with a voltage doubling capacitor configuration shown in Figure 18.

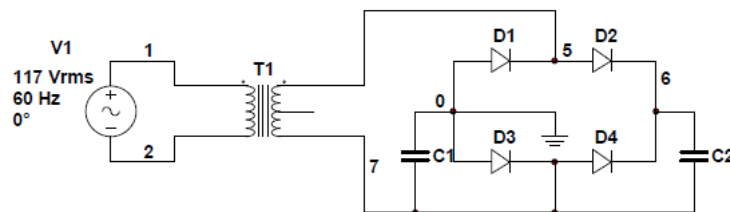

Figure 18: Voltage Doubling Capacitor / Rectifier Configuration

The input power will be first attached to a 1:1 isolation transformer. This configuration will result in a 330V unregulated signal. Alternatively, a 1:2 transformer could have been selected, and that signal rectified to the same 330V signal, still using a capacitor to filter the voltage to DC. Ideally, a transformer which would permit a peak voltage output closer to 200V would have been selected. Having a transformer at that voltage would mean less power dissipated in the power supply. Unfortunately, transformers at that specific output voltage were not readily available, and a standard 1:1 transformer

was chosen for the input. The capacitors C1 and C2 were chosen to provide a high amount of regulation for the first order analysis of the circuit. The minimum voltage on the input of the regulator block will be 240V. This will allow for the minimum drop-out voltage as well as some fine tuning if a slightly higher output voltage is desired. To determine the capacitor size, reference Figure 9 and solve for  $t_c$  as before (see page 29):

$$t_c = \frac{\cos^{-1}\left(\frac{240V}{360V}\right)}{2 * \pi * 60Hz} = 2.231mS$$

Now, solving for C as before with  $I = 16mA$ :

$$C = 6.102mS * \frac{-16mA}{(240V - 360V)} = 0.813\mu F$$

Since the two capacitors are in series, each of them must be  $1.626\mu F$  or more to provide the  $0.813\mu F$  desired.

The regulation block proved to be the most complex. There are few high voltage regulators available. Most regulators have a  $V_{in}$  to  $V_{out}$  differential of less than 50V [9]. In order to combat this, a design from National Semiconductor, shown in Figure 19 below, was used to "float" the regulator at a higher voltage [13].

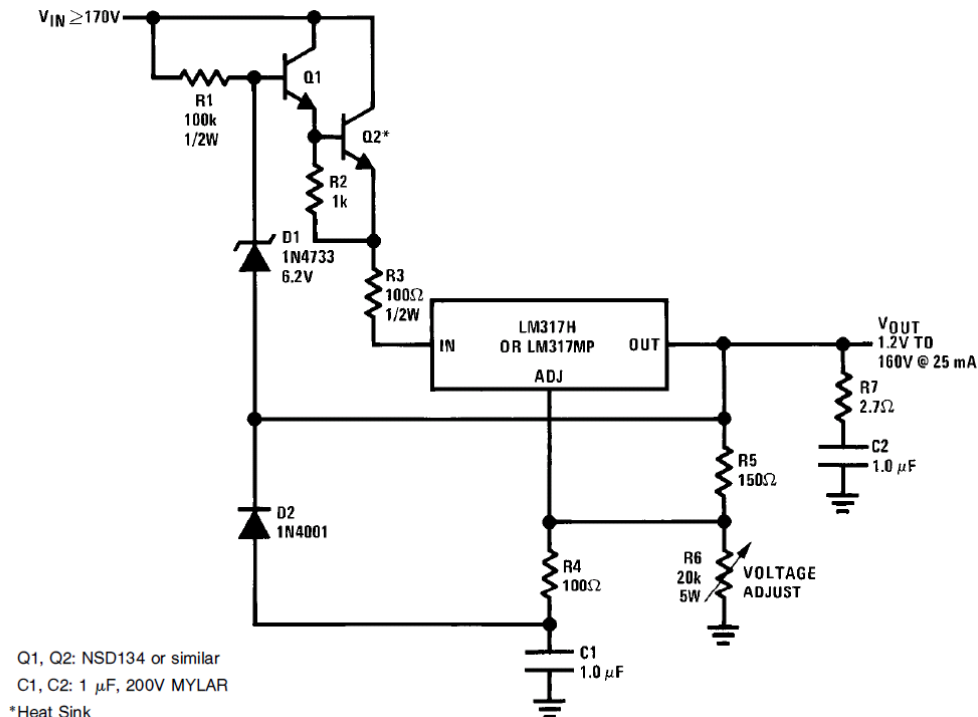

Figure 19: High Voltage Regulator from National Semiconductor [13]

Feedback from the output of the regulator feeds transistors Q1 and Q2 through a Zener diode which keeps the output voltage within 5V of the input voltage. In this way, the transistors bring the output voltage down to approximately the output voltage, and the regulator removes any residual noise and ripple on the signal [13]. The regulator chosen for this design was a National Semiconductor LM317 which has a maximum  $V_{in} - V_{out}$  differential of 40V.

As a first approach, this design was quickly prototyped. A SPICE model was not available from National Semiconductor's website, so no SPICE modeling was done before hand. In order to achieve a higher voltage than the recommended 160V maximum, TIP50 (which have a much higher  $V_{CE}$  maximum rating) transistors were substituted for Q1 and Q2. The datasheet for the TIP50 transistor is found in Appendix C. Preliminary tests of this design showed good regulation at extremely low current loads ( $R_L =$

10Mohm) however at higher current loads, the design began to fail, with the output voltage dropping much lower than 200V.

Using the SPICE model from Texas Instruments for the LM317, simulations were completed to look for the cause of failure. Figure 20 shows the Multisim Model used to simulate the circuit. Note that instead of modeling the transformer, a sinusoidal voltage source was used. Using this model, it was possible to pinpoint the problems with the initial design.

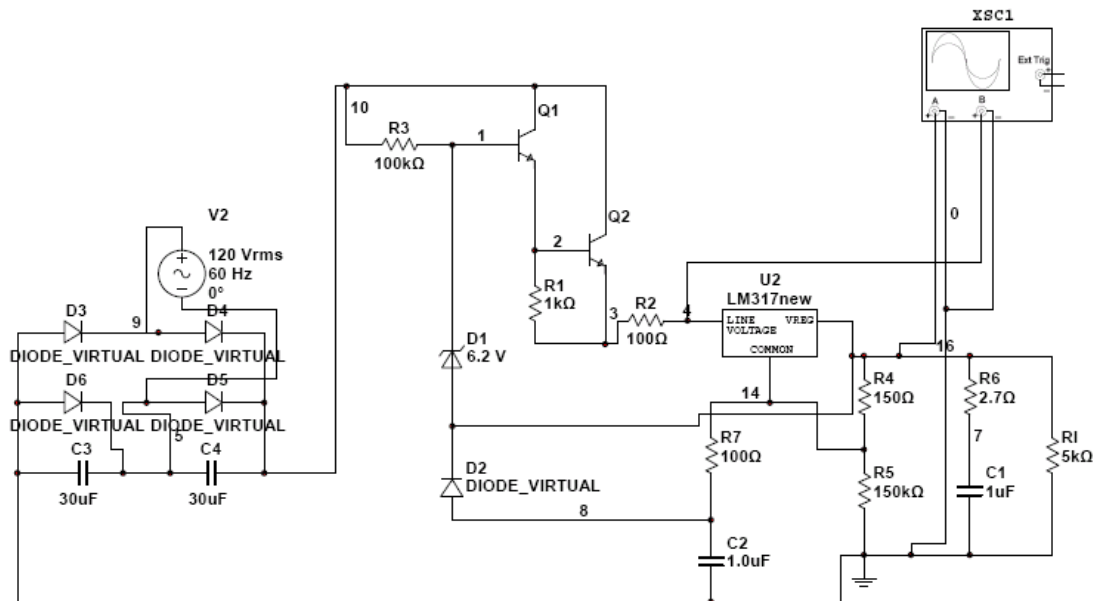

Figure 20: Multisim Model of Grid Power Supply (1st design) [13]

In order to test this design, different values of R1 were chosen, and the output observed. To set the experiment up, R1 was chosen to be 10MΩ. The voltage divider of R4 and R5 sets the output voltage to be at 200V. The capacitor C1 is required by the U2 to ensure output stability. Without the capacitor, small changes in the output current could cause oscillations in the regulator. Aside from modifications to R4 and R5, all of the component values came from Figure 19 [13].



The circuit failed when larger amounts of current were drawn from  $V_{out}$  because the amount of base current for Q1 could not compensate for the added loads. Simulations showed that with a 500k $\Omega$  load, that there was on an order of 150pA of current drawn from Q1. With a 50k $\Omega$  load most of the current flowing through R3 flows through the diode D1, and the base current was an order of magnitude lower, 15pA when it should have been much larger. Currents this low in simulation indicate that these transistors are driven into cutoff, increasing the  $V_{CE}$  across Q2, which lowers the output voltage.

In order to correct the design, series pass transistors were added to the model in order to reduce the output current drawn directly from the U2 [9]. These series pass transistors acted as a current amplifier. The  $V_{CE}$  will remain nearly constant at 0.7V, however the transistor will supply  $\beta^2 \cdot i_{base}$  on the output. This would reduce the current load being drawn from the regulator by  $\beta^2$  in the Darlington configuration shown in Figure 21. In this way, the load resistance seen by the regulator was increased significantly [9]. With these additions, simulations confirmed that the regulator properly regulated at 200V. Figure 21 below shows the circuit used for simulating this addition.



Replacing the regulator circuitry with the Supertex LR8 greatly reduced the complexity of the circuit since there was no longer a need to “float” the regulator at a higher voltage [16]. The datasheet for the Supertex LR8 is located in Appendix F [15]. A series pass transistor is used to increase the amount of current which can be drawn from the supply. Unfortunately, there is no SPICE model available for this regulator. Efforts made to contact the manufacturer about the device were fruitless. Figure 22 below shows the schematic for the supply with the Supertex regulator.

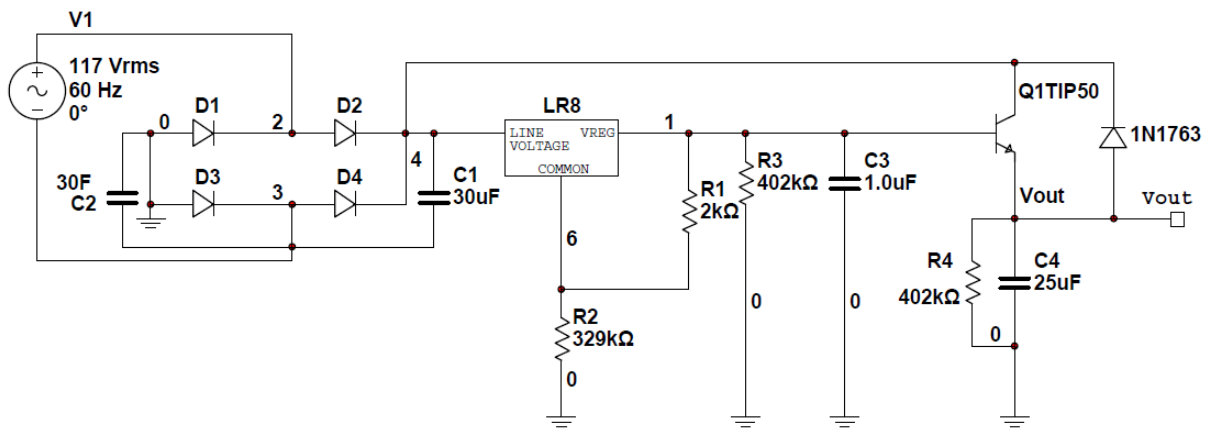

Figure 22: Grid Regulator Design with LR8

Notice that there is a 402kΩ shunt resistor, R3, attached to the output of the regulator. The regulator requires that a minimum 500μA of current is drawn to ensure stability. Because the supply will be switched on and off, R3 is in place to ensure this requirement. In addition, there is a 402kΩ resistor, R4, in parallel with the output capacitor to ensure that large amounts of energy are not stored in the capacitor when the circuit is disconnected from power. Also note that C1 and C2 were selected to be 30μF. Selecting a larger capacitor allows the circuit to be easily extended to higher currents. The resistors R1 and R2 were chosen based on the following formula from the LR8 datasheet:

$$V_{out} = 1.20V * \left(1 + \frac{R_2}{R_1}\right) + i_{adj} * R_2$$

Solving for R2 gives:

$$\frac{V_{\text{out}} - 1.2\text{V}}{\frac{1.2\text{V}}{R_1} + i_{\text{adj}}} = R_2$$

Evaluating for  $i_{\text{adj}} = 10\mu\text{A}$  typically,  $R_1 = 2\text{k}\Omega$ , and  $V_{\text{out}} = 200\text{V}$  yields:

$$\frac{200\text{V} - 1.2\text{V}}{\frac{1.2\text{V}}{2\text{k}\Omega} + 10\mu\text{A}} = R_2 = 325.9\text{k}\Omega$$

In practice, the value of  $329\text{k}\Omega$  was selected using a trim pot to account for variations in  $i_{\text{adj}}$  and the voltage drop  $V_{\text{BE}}$  in the output transistor.

Using the series pass transistor Q1TIP50, the regulator only needs to supply the base current to the transistor which is very low. It allows for much larger output currents as a precise output voltage. Even without using a Darlington pair to further amplify the current as in the previous design, this regulator works well. The circuit was built and tested on the bench. Several experiments were set up in order to test the power supply. Voltage was tested with no load, with  $10\text{k}\Omega$  load and with  $20\text{k}\Omega$  load. The regulation was stable in all cases.

The regulated circuit outputs to an electronic switch, which is controlled by the microcontroller. This switch pulse width modulates the  $200\text{V}$  signal in order to control the neutron flux. Originally, a design incorporating an optocoupler was considered because it would electrically isolate the microcontroller from the  $200\text{V}$  supply. However, it was found that the response of the optocoupler was too slow to be used in the design. The rise and fall times were on the order of  $40\mu\text{s}$  for optocouplers which could handle the voltage. An alternative design was considered which used transistors to switch the current. This design had the benefit of being much faster; however, it lacked the desired electric isolation of the optocoupler design.

The circuit, shown in Figure 23 below, uses two transistors to switch the output voltage high and low on to the load, modeled as  $R_L$ .

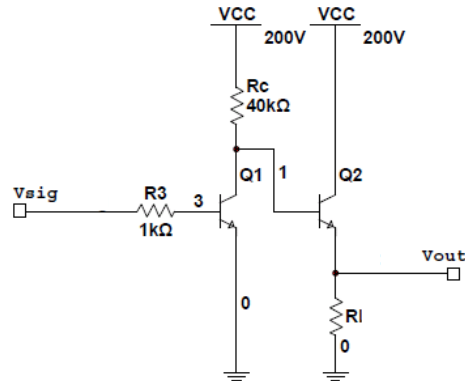

Figure 23: Electronic Switch Circuit

The transistor selected was the Fairchild Semiconductor 2SC3503FSTU transistor. This was selected because of the high voltage capabilities and the high transition frequency, the importance of which will be discussed later. The first transistor, Q1 inverts the signal. This is desired for two reasons. First, if the output were to be taken directly from the base of the second transistor, the load,  $R_L$  would be part of a voltage divider. Figure 24 below shows this circuit.

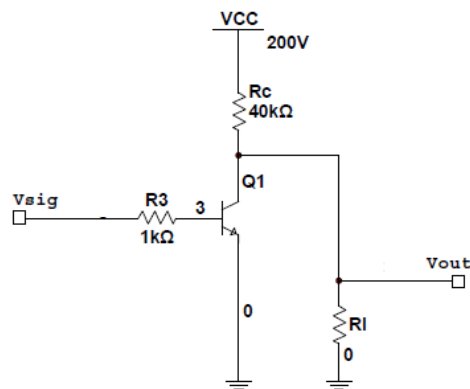

Figure 24: Common Emitter switch showing voltage divider output

The collector resistor  $R_c$  would need to be very low in order for the desired output voltage to be met, and this would cause unreasonable amounts of current to flow through the resistor when the output was “off”. In addition to this reason, it will oftentimes be unnecessary to operate the circuit with a pulsed output, and simply grounding  $V_{sig}$  will cause the switch to be on.

An alternative is to use an emitter follower configuration where the voltage output is taken from the emitter of the transistor. Figure 25 below shows this configuration.

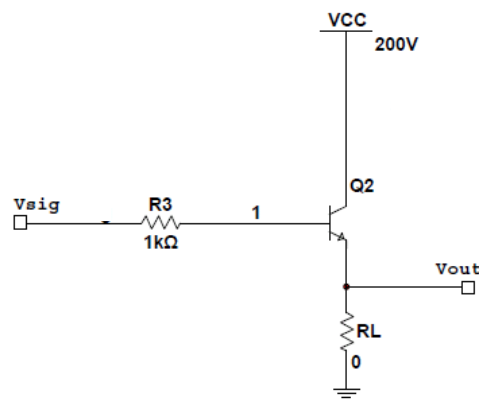

Figure 25: Emitter Follower switch showing large  $V_{BE}$

However, the input signal  $V_{sig}$  will be on the order of 2.7V from the microcontroller. Since a transistor in the forward active region, or in saturation, has a  $V_{BE}$  on the order of 0.7V, the microcontroller output voltage would need to be 200.7V in order to properly bias the transistor on. For this reason a common emitter stage is used to amplify the signal from the microcontroller to approximately 200V. Then this signal is fed into a emitter follower stage where the concerns about the output being part of a voltage divider are no longer present.

One difficulty using a transistor switch is the delay caused by removing the saturation charge from the base when switching the transistor off. In order to reduce  $V_{CE}$  as much as possible, the transistor is put into the saturation region [17]. In order to accomplish this, excess charge is pumped into the base of the transistor [18]. In order to turn off the transistor, this charge must be removed which takes time.

Until this charge is removed, the transistor remains in saturation and only once that charge has been removed does it traverse the forward active region eventually resting in the cutoff region. Additionally, when the transistor is turned off, current flows out of the base terminal. It is desirable to have this current leave the base as quickly as possible in order to increase the switching speed [18]. For this reason, a low base resistance is chosen. In addition, the transition frequency of the transistor affects the switching speed [18]. The transition frequency for the transistor is dependent on the collector current. For the transistors selected, the optimal transition frequency occurred around 30mA of collector current [19]. However, at 5mA of collector current, there was not a significant change in transition frequency. By paying a small price in transition frequency, a significant reduction in power dissipation was earned. The collector resistor on Q1 is 40k $\Omega$  which causes 5mA of current to flow through Q1. This resistor dissipates 1W of wasted power, however it is necessary in order to achieve an acceptable switching speed. An alternative design might utilize MOSFET switches. MOSFET switches do not have this problem, however a MOSFET which could take a  $V_{GS}$  of >200V could not be practically found.

The final design for the regulator is shown below in Figure 26.

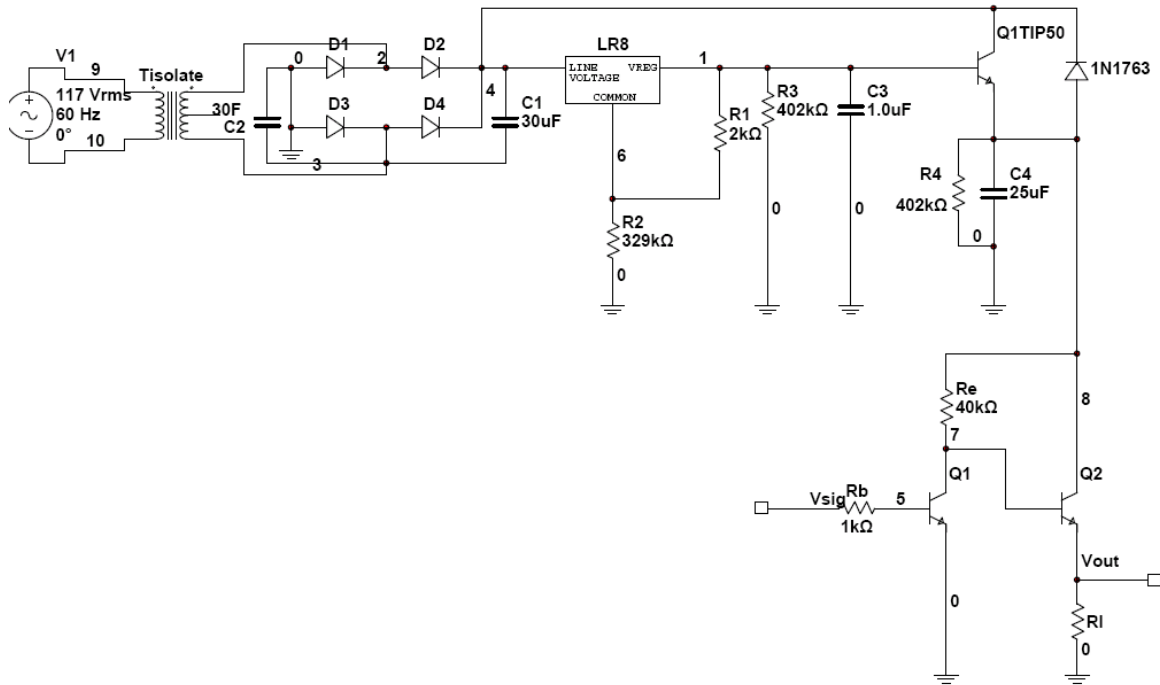

Figure 26: Final Regulator Design

### Power Dissipation Analysis

The power dissipation analysis is important. At nominal operating point, the power supply delivers 10mA at 200V. This is a delivery of 2W. Also in the power supply, Figure 22, several components dissipate power into heat. The power dissipated by the bridge rectifier is insignificant and will be ignored. The transistor Q1 nominally has a  $V_{CE}$  of 130V. At a nominal load of 10mA, combined with another 5mA being drawn from the electronic switch, the power dissipated in the transistor is given by:

$$P_{\text{Transistor}} \approx V_{CE} * I_C$$

$$130V * 15mA \approx P_{\text{Transistor}} = 1.95W$$

This component will need to have an appropriate heat sink attached to it in order to safely dissipate this heat load. There are two 402kΩ shunt resistors with 200V across them. Power dissipated in a resistor is given by:



$$P_{\text{Resistor}} = \frac{V^2}{R}$$

$$\frac{200V^2}{402k\Omega} = P_{\text{Resistor}} = 99.5mW$$

The voltage divider should also be considered:

$$\frac{200V^2}{331k\Omega} = P_{\text{Voltage Divider}} = 120.8mW$$

With a minimum large signal beta of 30, the transistor bias current is 333.3 $\mu$ A or less supplied from the LR8. With a large input capacitance, the input voltage to the regulator is approximated as 330V. With 130V across the LR8, the power can be calculated:

$$P_{\text{Regulator}} \approx V_{\text{Differential}} * I_{\text{output}}$$

$$130V * 333.3\mu A \approx P_{\text{Regulator}} = 43.3mW$$

The total power dissipation is:

$$P_{\text{Transistor}} + 2 * P_{\text{Resistor}} + P_{\text{Voltage Divider}} + P_{\text{Regulator}} = P_{\text{total}}$$

$$1950mW + 2 * 99.5mW + 120.8mW + 43.3mW = P_{\text{total}} = 2.31W$$

With 3W being delivered, 1W to the switch and 2W to the Minitron, this gives an efficiency of:

$$\text{Efficiency} = \frac{P_{\text{delivered}}}{P_{\text{dissipated}} + P_{\text{delivered}}} * 100\%$$

$$\text{Efficiency} = \frac{3W}{2.31W + 3W} * 100\% = 56.4\%$$

The stability of this circuit depends on two factors. First, the stability depends on the stability of the LR8 regulator. The regulator is guaranteed to be stable to within 3% for a current change of 0.5mA to 10mA

at an output of 5V. Since the change in base current to the series pass transistor will be very small compared to the constant current drawn from the 402k $\Omega$  resistor, this leads one to believe that the stability of the regulator will not be significant. However, this will need to be tested in the final design.

The second factor depends on the  $V_{BE}$  of the TIP50 series pass transistor. This factor is mostly dependent on temperature and the collector current. However, it ranges from 0.6V to 1.01V over an  $I_c$  current range of 10mA to 2A. A change of 0.4V corresponds to less than 0.5% of the output voltage, so the stability of the series pass transistor will also likely be insignificant. However, this will need to be tested in the final design.

### Aside

If a higher switch frequency was needed, one possible design enhancement would be to use an emitter switch configuration for the electronic switch shown below in Figure 27

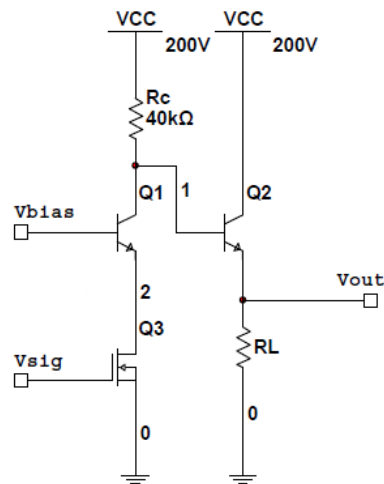

Figure 27: Emitter Switching for Faster Switch Times

This design uses a MOSFET to switch the current in a transistor. This has the benefits of decreasing the current drawn from the microcontroller. This will also give an improvement in the switching speed [18].

### 30kV Controller Interface

The 30kV controller interface programs the 30kV power supply output. The circuit, which can be seen in Figure 28, explains the functionality of the front-end interface and the connections to each of the pins of the DA-15 connector.

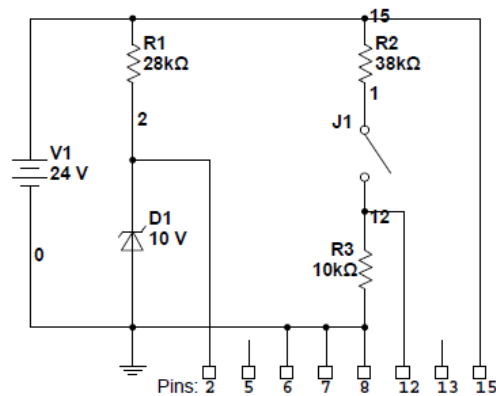

Figure 28: 30kV Controller Interface Schematic

R1 and D1 provide a 10V signal to pin 2, which specifies that 30kV is desired at the output. R2 and R3 provide a TTL high signal to pin 12, connected with a switch. This allows the controller to turn on and off the power supply. Pin 15 provides power to the supply, and 6, 7, and 8 should normally be grounded. The circuit is powered by a 24V power supply. Each pin shown in the figure above has a specific function. Table 4 lists all of the pins in the DA-15 interface connector and, if the pin serves a purpose, describes the function of the pin.

PIN	SIGNAL	SIGNAL PARAMETERS
1	Spare	n/c
2	Voltage Program	0 to 10V = 0 to 100% Rated Output
3	Spare	n/c
4	Spare	n/c
5	Voltage Monitor	0 to 10V = 0 to 100% Rated Output
6	TTL Polarity Control Signal	Hi = Positive Polarity, Low = Negative Polarity
7	Signal Ground	Signal Ground
8	Power Ground	Power Ground
9	Spare	n/c
10	Spare	n/c
11	Spare	n/c
12	TTL HV Enable	Hi = Inhibit, Low = Enable
13	Current Monitor	0 to 10V = 0 to 100% Rated Output
14	Spare	n/c
15	+24Vdc	+24Vdc, up to 2A

**Table 4: DA-15 Connection List**

As can be seen in the figure and the table, pin 2, or the voltage program, controls the voltage output of the 30kV power supply. Figure 28 displays only one of the values available to pin 2. With a switch used with the diode configuration shown above, the user will be able to choose from 4 different voltages: 10kV, 15kV, 20kV and 30kV. Pin 5 will be used to monitor the voltage being passed through pin 2. Pin 6 controls whether the voltage at pin 2 is positive or negative. This is done by providing pin 5 with either a hi or low signal. Since the Minitron expects a voltage of -30kV, pin 6 may be connected directly to ground. Pin 7 and pin 8, being signal and power ground shall share the same value as pin 6. By sending either a logic 1 or logic 0 signal to pin 12, the user may decide whether the high voltage is enabled or disabled. Pin 15, as can be seen in the table, will take in a voltage source of +24Vdc. After the designs were completed, the circuit was created and mounted, which can be seen in the following image:

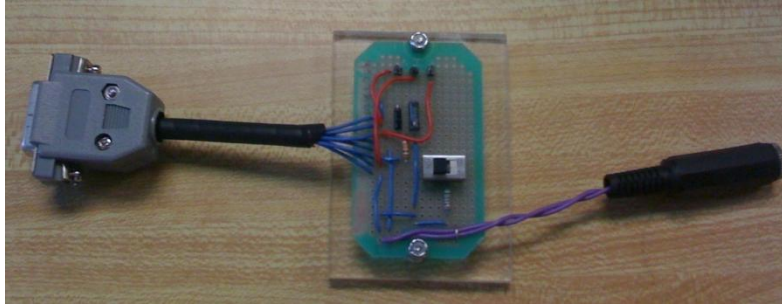

Figure 29: Photograph of First Controller Interface

Figure 29 shows the first design of the controller interface with only one available voltage being placed into pin 2. The connector shown on the left side of the photograph is known as a DA-15 connector and contains a total of 15 pins arranged in the following manner:

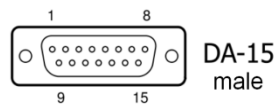

Figure 30: DA-15 Interface Connector [20]

Before the controller was connected to the 30kV supply, each of the relevant pins was tested for functionality on the bench. A more rigorous testing routine is described in the testing section.

## Chapter 3: Testing

### Cathode and Filament Power Supplies

The Cathode and Filament power supplies deliver the most amount of power as compared to any of the other supplies. In order to determine if this supply is functional, it will need to pass several tests. The output voltage while loaded will need to be stable to within 10%. In addition, the ripple on the output line must be less than 3%. The junction temperature will also be calculated to ensure that the components are not generating too much heat.

### Output Voltage Ripple

The ripple on the output voltage line is of moderate interest. Because these supplies are being used to power a heating coil, which requires only low precision, the output voltage ripple is not critical to the design. However, it is still desired to have a low value of 3% for the output ripple voltage. In order to test this the supply will be attached to a 1Ω load. An oscilloscope will be attached to the output terminals and set to the AC coupling setting in order to measure the ripple. In addition, the ripple across the input capacitor (C1 in Figure 14 on page 35) will be measured. This will help ensure that the voltage on the input capacitance never drops to 1.5V above the target output voltage.

This testing was completed on 18 Apr. 2009. The results are summarized in Table 5 below.

Test	Measurement
Output Voltage Ripple	<1mV pk-pk
Capacitor Voltage	>6.52V

**Table 5: Ripple Test Results**

The test results gave an output voltage ripple of less than 1mV pk-pk. This is extremely small, and is considered negligible. This meets the 3% ripple criteria. The voltage on the capacitor never dropped below 6.52V, indicating that there was no danger of approaching the 4.4V minimum regulator input voltage required to maintain 3V on the output. The regulator passed these tests. In addition, the supply

was tested with a varying wall supply voltage. Using a variac, the RMS value of the input voltage was set at 117V, 125V, and 105V to determine if there was any change in the output. For this test, the supply was preset at 3V using a 1 $\Omega$  load. The results are shown in Table 6 below.

RMS Input (V)	Measured Output (V)	Input Variation (%)	Output Variation (%)
105	2.999	-10.26	-0.033
117	3.003	0.00	0.100
125	2.992	6.84	-0.267

**Table 6: Grid Test Results with Varying Input Voltage**

These tests indicate that the supply operates at voltages  $\pm 5\%$  of the nominal 117V RMS of standard wall power.

### Thermal Stability

The Cathode and Filament supplies dissipate a considerable amount of power in the voltage regulator.

The power, dissipated in the form of heat, causes the supplies to heat up. The regulators in use, AP1084, can adequately regulate at a junction temperature of up to 125°C [11]. In order to keep the temperature below this, the regulators are supplied with heat sinks to dissipate heat more rapidly. The purpose of this test is to ensure that the junction temperature does not exceed this maximum 125°C. In addition, the regulator stability with temperature will be measured.

For this test, the regulator will be pre-set to 3V at 3A (on a 1 $\Omega$  load). The regulator will be turned on, and the output voltage will be measured. After 10 minutes of run time, the temperature of the regulator will be measured using an infrared thermometer. The output voltage will also be measured to see the change with respect to temperature.

After 10 minutes, the temperature measured on the regulator was 78°C. The datasheet gives the thermal junction to case resistance of  $\Theta_{th} = 3.5 \text{ }^\circ\text{C/W}$ . The circuit in Figure 31 below can be used to approximate the junction temperature.

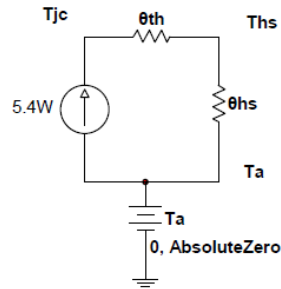

Figure 31: Thermal Circuit

With  $\Theta_{th} = 3.5 \text{ }^\circ\text{C/W}$ ,  $T_A = 20^\circ\text{C}$ , and  $T_{HS} = 78^\circ\text{C}$ , the junction temperature is found as follows:

$$T_{jc} = T_{HS} + 5.4\text{W} * \Theta_{TH}$$

$$T_{jc} = 78^\circ\text{C} + 5.4\text{W} * 3.5 \frac{^\circ\text{C}}{\text{W}} = 96.9^\circ\text{C}$$

This junction temperature, while high, is far below the maximum functioning temperature of  $125^\circ\text{C}$ .

Even with the substantial increase in temperature, the regulator remained very stable. At the beginning of the test, the voltage was measured at 3.02V. At the end of the test, the voltage had dropped by 10mV to 3.01V. This represents a change of 0.33%. This is far below the 10% requirement of the supply. Considering the small range of necessary operating temperature, between  $25^\circ\text{C}$  and  $20^\circ\text{C}$ , and the large amount of temperature and voltage margin, this test demonstrated satisfactorily that the supply meets the temperature specification. Because there was not a reliable way to heat the testing apparatus to  $25^\circ\text{C}$ , no test was done at this temperature.

## Grid Power Supply

The 200V Grid Power Supply is the most complicated supply to test because of the pulsed output. In order for this supply to be deemed functional, it must pass several tests. The output voltage stability must be maintained over a range of output current loads. The ripple on the output voltage line will also be measured, excluding switching transients. The thermal stability of the supply will also be tested to ensure that the supply will not over heat and that the pass transistor has a proper heat sink. In addition, the switching transients will need to be analyzed at a variety of output currents.



### Output Voltage Stability

The output voltage stability is the first metric used to determine if the supply is working properly. In order to perform this test, the supply will be loaded with several different resistive loads and the change in output voltage will be measured. To perform the test, the supply will first be calibrated at the nominal current level of approximately 10mA. After this, a variety of different output loads are attached and the change in output voltage is measured. Table 7 below shows the loads to be used in the test.

Load	Target Current	Target Power
10k $\Omega$	20mA	4W
20k $\Omega$	10mA	2W
40k $\Omega$	5mA	1W
100k $\Omega$	2mA	400mW
1M $\Omega$	0.2mA	40mW

**Table 7: Test Loads and Predicted Current and Power for 200V supply**

To complete this test, the supply will be attached to standard wall power, 117V AC 60Hz. The output voltage will be measured by a multimeter attached across the load resistor. After adjusting the supply to the 20k $\Omega$  resistor, the other resistors will be attached and the output voltages measured. The supply will be running at DC or 100% duty cycle.

The test was completed on 21 April 2009. Table 8 shows the results of this test.

Target Load (k $\Omega$ )	Measured Load (k $\Omega$ )	Measured Output (V)	Error (%)
10	9.623	200.020	0.010
20	22.316	200.001	0.001
40	33.53	200.010	0.005
100	99.706	200.070	0.035
1000	9985	200.045	0.022

**Table 8: Grid Testing Results with Varying Loads**

These results show that the error is far less than the 3% allowable. The maximum observed error was 0.035%, which is excellent and demonstrates the stability of the supply designed. In addition, the supply was tested with a varying input voltage. Using a variac, the RMS value of the input voltage was set at

117V, 125V, and 105V to determine if there was any change in the output. For this test, the supply was preset at 200V using a 22.316k $\Omega$  load. The results are shown in Table 9 below.

RMS Input (V)	Measured Output (V)	Input Variation (%)	Output Variation (%)
105	200.140	-10.26	0.070
117	200.001	0.00	0.001
125	199.970	6.84	-0.015

**Table 9: Grid Test Results with Varying Input Voltage**

These tests indicate that the supply operates at voltages  $\pm 5\%$  of the nominal 117V RMS of standard wall power.

### Output Voltage Ripple

Unlike the 3V supply, the ripple on the output of the 200V Grid supply is important. This supply should have less than 3% ripple on the output line to be deemed functional. In order to test this, the ripple will be measured with an oscilloscope at 10mA output current. An oscilloscope will be attached across the load in AC coupling mode and the peak to peak ripple value will be measured. Using a load of 22.316k $\Omega$ , the peak to peak ripple was measured to be 5mV. This corresponds to 0.0025% ripple. This meets the specification of <3% ripple.

### Thermal Stability

The thermal stability of the supply is of interest because the supply will be dissipating a considerable amount of power into heat through the series pass transistor. The functionality of this transistor is guaranteed only if the junction temperature is lower than 125°C. The transistor is supplied with a heat sink in order to help it dissipate heat rapidly. For this test, the regulator will be pre-set to 200V at 16mA. During previous testing, it was observed that after 5 minutes, the temperature appeared to have reached its final value, and no noticeable additional increase in temperature was observed. For testing, this amount of time was doubled to 10 minutes. For the test, the regulator will be turned on and after

10 minutes of run time, the temperature of the regulator will be measured using an infrared thermometer.

After 10 minutes, the temperature measured on the regulator was 41°C. From the datasheet a junction to case resistance of  $\Theta_{th} = 3.125 \text{ }^\circ\text{C}/\text{W}$  is calculated. With this, the circuit in Figure 32 below can be used to approximate the junction temperature.

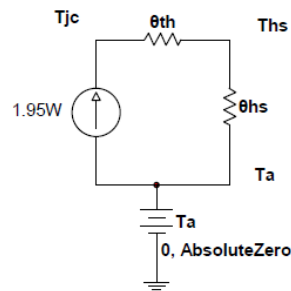

Figure 32: Thermal Circuit

With  $\Theta_{th} = 3.125 \text{ }^\circ\text{C}/\text{W}$ ,  $T_{HS} = 41^\circ\text{C}$ , and  $T_A = 20^\circ\text{C}$ , the junction temperature is found as follows:

$$T_{jc} = T_{HS} + 1.95\text{W} * \Theta_{th}$$

$$T_{jc} = 41^\circ\text{C} + 1.95\text{W} * 3.125 \frac{^\circ\text{C}}{\text{W}} = 47.1^\circ\text{C}$$

This is far below the maximum temperature of 150°C. Considering the small range of necessary operating temperature, between 25°C and 20°C, and the large amount of temperature margin, this test demonstrated satisfactorily that the supply meets the temperature specification. Because there was not a reliable way to heat the testing apparatus to 25°C, no test was done at this temperature.

### Switching Transients

The output of the 200V supply is attached to an electronic switch comprised of two transistors. These transistors turn the output on and off rapidly at approximately 1kHz. In order for the supply to be deemed functional, the rise and fall time of the output must be relatively short compared to the period of the switching frequency. Since the supply may be operated down to a 10% duty cycle, a minimum rise and fall time of 10µs is required. 10µs is 1% of the total period at 1kHz. To test this, the supply will

be run at 16mA at a 50% duty cycle. The output will be measured using an oscilloscope connected across the load.

Testing indicates that this supply meets the switching requirements. Figure 33 below shows the switching transient turning the output off.

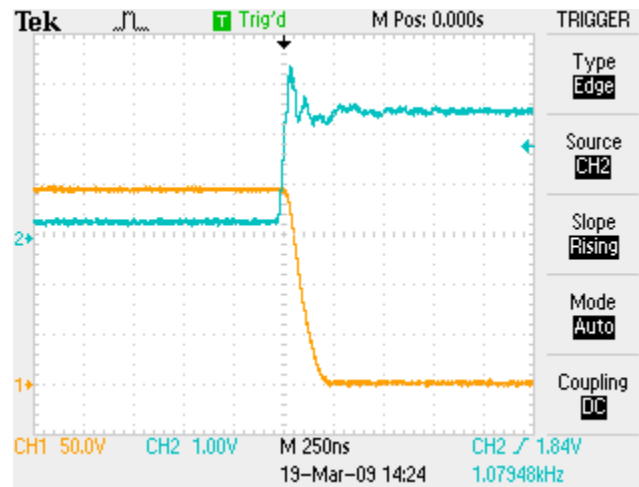

Figure 33: Switching Transient Turning Off. Blue Trace – Input (1V/div), Orange Trace – Output(50V/div) Time: 250nS/div

The blue trace is  $V_{sig}$  and the orange trace is the output voltage. Note that the transition happens in less than 250nS. This is well below the 10 $\mu$ S requirement. The slower transition is turning the supply on.

Figure 34 shows the switching transient turning the output on.

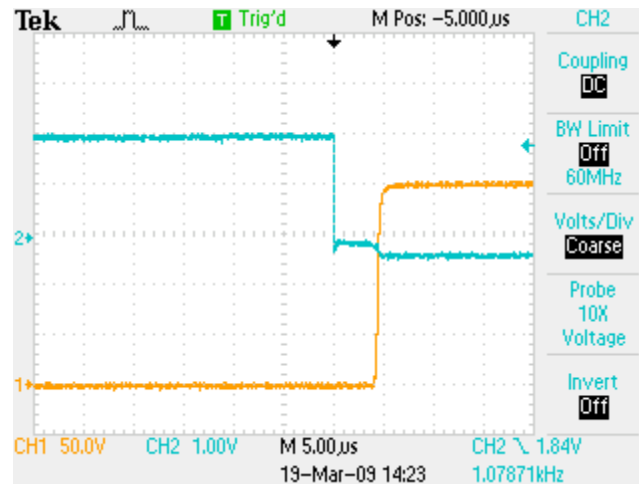

Figure 34: Switching Transient Turning On. Blue Trace – Input (1V/div), Orange Trace – Output(50V/div) Time: 250ns/div

Again, the blue trace is  $V_{sig}$  and the orange trace is the output voltage. Note that this transition takes only  $1\mu\text{s}$  to complete, but there is a significant latency of  $4\mu\text{s}$ . This is because the transistors are being driven into saturation. This test demonstrates that the electronic switch meets the  $10\mu\text{s}$  rise and fall time criteria.

### 30kV Controller Interface

The 30kV controller was tested on 9 March 2009 at the Bates Linear accelerator facility. The purpose of the test was two-fold. First, it was desired that the output of the controller was verified, and the expected voltages were delivered to the output pins. Having completed that, it was possible to attach the controller to the power supply in order to test the output of the supply.

#### Output of the controller

The controller interacts with the 30kV power supply by sending various voltages and control signals to the power supply. In order to test the functionality of the controller, these voltages needed to be tested. Of interest were the following pins:

- Pin 15: 24VDC power
- Pin 12: High Voltage Enable
- Pin 8: Power Ground
- Pin 7: Signal Ground

- Pin 6: HV Polarity
- Pin 2: Voltage Program

These would be tested by applying 24 Volts to the input (V1 in Figure 28) and measuring with a voltmeter the output voltages. For pin 12, two measurements would be taken, one with the switch closed, and one with the switch opened.

Before bringing the controller to Bates for final testing, all of the pins were tested and passed at WPI. However, when testing began at Bates the controller was not functioning properly. There was no consistency in the measurements, and the proper voltages were not being observed. Unfortunately, while attempting to determine what the problem with the board was, one of the probes caused a hard short over the power supply rails and destroyed the power supply.

It was determined that a faulty solder bridge which connected the power supply ground to the rest of the circuit was the cause of the problem. After fixing this problem, and using a bench supply, the output of the controller was verified. Table 10 below shows the criteria used to pass the board. In order for the board to pass, each pin must pass.

Pin	Description	Pass Criterion
15	24 VDC Power	Error < 2%
12	HV Enable (J1 Open)	Value < 0.1V
12	HV Enable (J1 Closed)	Value > 4.5V
8	Power Ground	Value < 0.01V
7	Signal Ground	Value < 0.01V
6	HV Polarity	Value < 0.1V
2	Voltage Program	Error < 2%

**Table 10: Pass Criteria for 30kV controller Testing**

The input voltage pin 15 must be within 2% of the nominal voltage, 24V. This is derived from the power requirements of the TOF3000 which can be seen in Appendix A. For pin 12 with J1 open the criterion is a value of less than 0.1V. This is a TTL input which should be set in the low position. Therefore, if the value is less than 0.1V the pin is guaranteed to be in the low position. For pin 12 with J1 closed the

criterion is a value greater than 4.5V. Again, this is a TTL input. With a value larger than 4.5V the pin is guaranteed to send a logic high. The two grounds, pins 8 and 7 are tied together and tied to the input power supply ground. As such, a value larger than a few mV would indicate some problem in the circuit. Pin 6 controls the polarity of the output voltage and uses a TTL input. For the same reasons as pin 12, this criterion is set at having a value smaller than 0.1V. Pin 2 controls the output voltage of the supply. An error of less than 2% is desired for this pin.

Having defined the passing criteria for the test, the results are listed below in Table 11.

Pin	Description	Expected	Observed	Units	Error	Pass Fail
15	24 VDC Power	24.00	23.90	V	0.42%	Pass
12	HV Enable (J1 Open)	0.00	0.00	V	0.00%	Pass
12	HV Enable (J1 Closed)	5.00	4.83	V	3.40%	Pass
8	Power Ground	0.00	0.00	V	0.00%	Pass
7	Signal Ground	0.00	0.00	V	0.00%	Pass
6	HV Polarity	0.00	0.00	V	0.00%	Pass
2	Voltage Program	10.00	9.90	V	1.00%	Pass

Table 11: Testing results for 30kV controller

All of the pins passed the test. The variation in the DC power was well within acceptable limits. The HV Enable pin outputs acceptable TTL values. The Signal and Power ground were at zero, as expected. The HV polarity was also at zero as expected. The Voltage Program pin had an error of 1%, which is less than the 2% passing criterion.

### Output of the supply

Having verified the functionality of the controller, the final test is to observe the output of the 30kV supply. As mentioned earlier, the supply in use is a Spellman TOF 3000. This supply features both a voltage and current feedback pin. These pins allow the use to measure a smaller voltage (0V - 10V) which is proportional to the output voltage or to the output current. For this experiment, both the direct output voltage as well as the feedback output voltage and current would be measured. The direct output current would be calculated and compared with the feedback current result.

The criterion for passing this test is for the output voltage to be within 1% of the programmed voltage. In order to test the output voltage a 950M $\Omega$  load will be used. At the desired voltage of 30kV, this would result in a current draw of 31.50 $\mu$ A. Attached to the load is also a Fluke80k-40 high voltage probe. This probe connects to any voltage meter and gives a reading of 1000 times less than the measured voltage. This volt meter has an input resistance of 1G $\Omega$ , so it will affect the current drawn from the supply. The expected current draw is 61.59 $\mu$ A. In addition, another voltage meter would measure the voltage feedback and current feedback pins. Since no testing enclosure was made for this testing procedure, the power was turned on remotely and all personnel were out of the room while the high voltage was on. Table 12 below shows the results of this test.

Measurement	Expected	Interpolation	Observed	Interpolation	Units	Error	Pass / Fail
Program Voltage	10.00	-30000.00	9.90	-29700.00	V		
Output Voltage	-29.70	-29700.00	-29.68	-29680.00	V	0.07%	Pass
Voltage Feedback	9.89	-29680.00	9.90	-29700.00	V	-0.07%	Pass
Current Feedback	1.539V	61.57 $\mu$ A	1.547V	61.88 $\mu$ A		-0.52%	Pass

Table 12: 30kV supply output test results

By the definition of the passing criterion, the supply has passed this test. It is also pertinent to note that a crackling noise was observed while the supply was on, in addition to the observation of several small pieces of paper being attracted to the testing apparatus. The crackling noise is generally indicative of corona, which produces wideband noise and would be unacceptable in a final product.

## Minitron

The Minitron would need to be tested at MIT Bates Laboratories. There are several safety factors which need to be taken into consideration before the Minitron can be turned on. Primarily, there will need to be shielding from the radiation dosage from the source and proper insulation from the high voltage from the -30kV source. In addition, there must be proper precautions taken to ensure that the Minitron itself is not damaged.



### Test Setup

A dry run of the test was conducted at the Bates facility on 9 April 2009 to verify the test setup. The Minitron is housed in a custom made acrylic gas chamber and supported by two custom made Teflon spacers. This chamber has two feed throughs, one for the low voltages (Grid, Cathode, Filament, and ground) and one for the high voltage(-30kV HV Signal). Figure 35 shows a model of the acrylic tube with the Minitron supported inside .

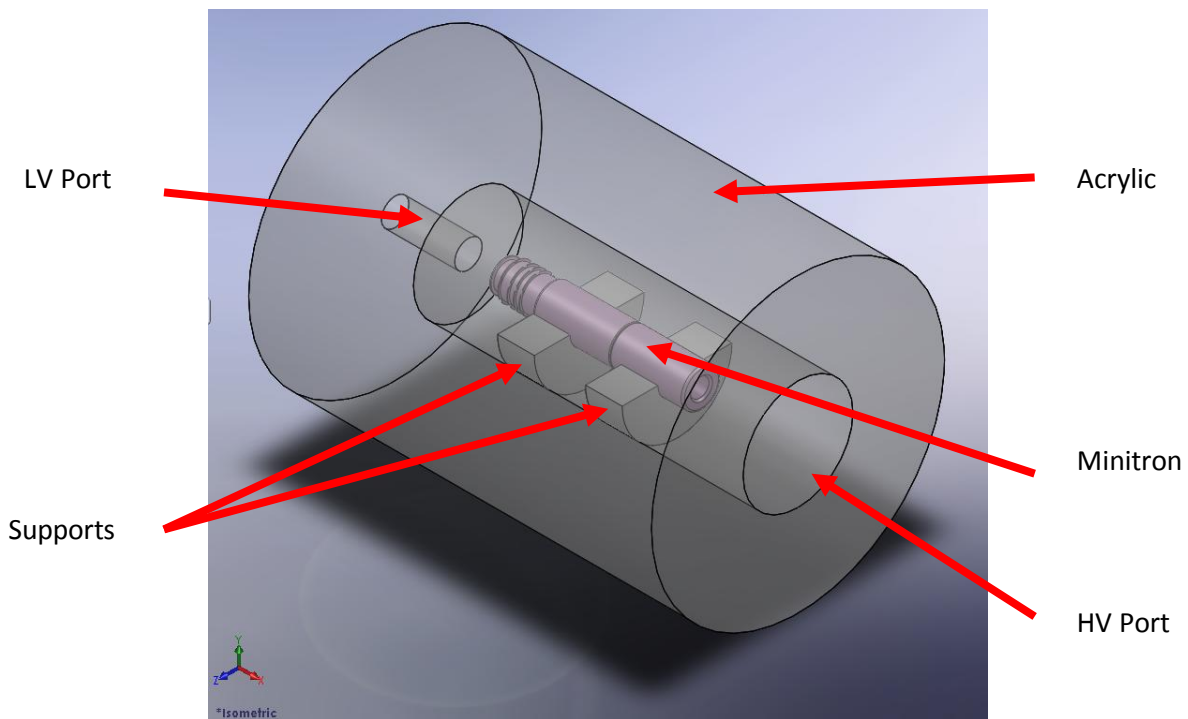

Figure 35: Minitron Testing Chamber Model for Radiation Protection

This model was used to help determine the predicted radiation dose rates while the device is in operation. Before testing can begin, the radiation protection department at MIT Bates must ensure the safety of the staff working at the facility. The acrylic tube provides some neutron shielding because it is rich in hydrogen. When neutrons collide with hydrogen, they lose a considerable amount of energy [21]. It was decided that the dose rates would be low enough, and the acrylic would provide enough shielding for humans to safely work in close proximity to the device. A small amount of extra shielding would be added in the final test setup.

In addition, the chamber has two gas ports for filling the chamber with Sulfur Hexafluoride ( $\text{SF}_6$ ) insulating gas which are not pictured in Figure 35. Figure 36 below shows a labeled photo of this chamber.

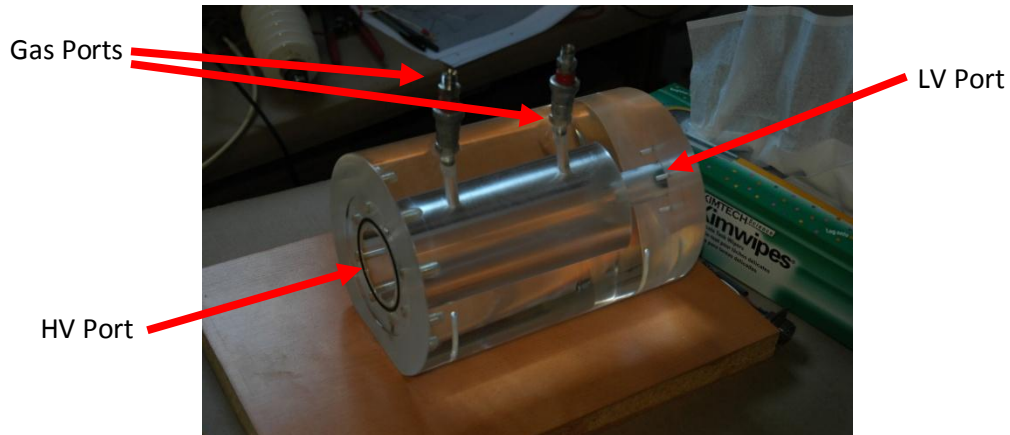

Figure 36: Testing Chamber

The Minitron is placed inside of the acrylic tube and set on the Teflon spacers. The low voltage wires are attached to the low voltage feed through. The low voltage feed-through has been sealed with epoxy to make it air-tight. It is bolted to the acrylic tube with a layer of RTV-103 sealant to make an air tight seal. A wire screws into the corona shield of the Minitron and attaches via a clip to the high voltage feed through. The high voltage feed-through flange is bolted to the acrylic tube with an O-ring, which makes the chamber air-tight. After this has been completed, the power supplies are attached to the feed-throughs. The high voltage supply is connected to a wire which is soldered to a washer, bolted to the end of the feed-through. The low voltage supplies are connected via a standard 6 pin connector. Figure 37 below shows the bench with the Minitron connected to the feed-throughs.

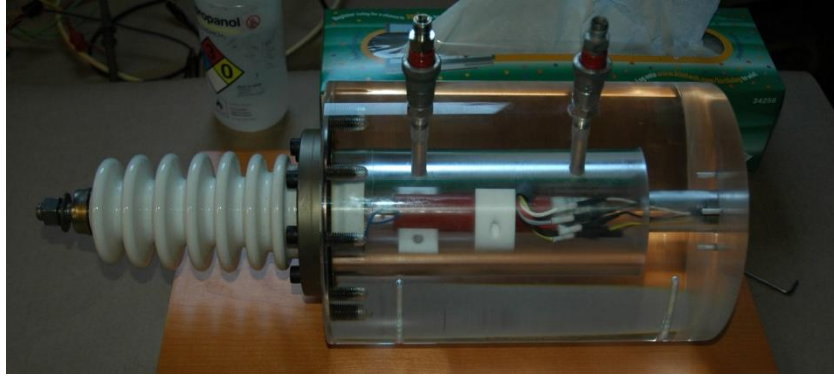
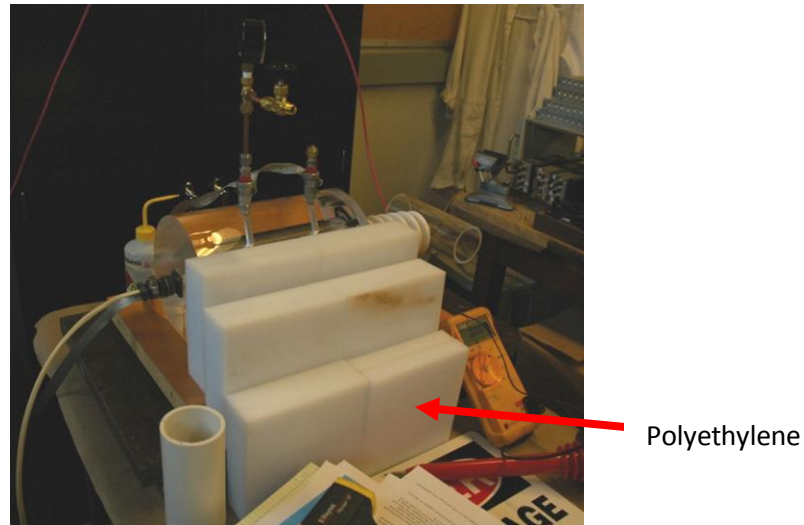

Figure 37: Minitron connected to feed-throughs

Once the supplies are connected, the gas ports are connected to the SF<sub>6</sub> bottle. SF<sub>6</sub> is pumped into the chamber to provide insulation inside the chamber. The chamber is filled until the pressure inside is 7psi. The chamber has an extremely low leak rate, 7 days after the test was completed, there was no discernable drop in pressure.

Once the gas ports are connected, the neutron insulation must be put in place. MIT uses polyethylene blocks to insulate against neutrons because it is very rich in hydrogen. Other good neutron insulators are water and borated plastic. Neutron detectors will be placed both inside the insulators, to measure the neutron flux from the device, and outside the insulators, to measure the neutron flux penetrating the insulation. Figure 38 below shows the final setup with the neutron insulation in place.



**Figure 38: Final Setup with Neutron Insulation in Place**

Having shielded against the high voltage with the  $\text{SF}_6$  and against the neutrons with polyethylene, it is now safe to turn on the power supplies. However, for the dry run, the power is disconnected from the Minitron and tested independently. The loads are attached to the low voltage cable so that the power supplies can be tested in conditions as close to actual running conditions as possible. The Cathode and Filament loads are simulated using a  $1\Omega$  resistor, and the Grid load is simulated using a  $22.5\text{k}\Omega$  resistor.

Having disconnected the Minitron, the electrical testing could begin. The AC line which powers the Grid Cathode, Filament, and high voltage supplies was plugged in. All three of the low voltage supplies were attached to an oscilloscope for calibration and monitoring. At the start, the Cathode and Filament supplies were running at approximately  $1.5\text{V}$  each. The Grid supply was turned off. The voltage on the Cathode and Filament supplies was slowly increased to the target values of  $2.5\text{V}$ . After this had been done, the Grid supply was turned on in DC mode (no pulsing). If the test was being run with the Minitron, at this point the  $30\text{kV}$  supply would be turned on. With all of the supplies in DC mode, the test was run for 10 minutes. At the end of the test, there was no detectable difference in the output of the Grid, Cathode, or Filament supplies. The temperature of the heat sinks was measured, and the results given in the table below.

Item	Temp.	Max Temp.	Units
Cathode Regulator	78	125	°C
Cathode Regulator Heat Sink	68	-	°C
Cathode Transformer	34	-	°C
Cathode Bridge	34	150	°C
Cathode Load	97	-	°C
Filament Regulator	78	125	°C
Filament Regulator Heat Sink	80	-	°C
Filament Transformer	29	-	°C
Filament Bridge	33	150	°C
Filament Load	95	-	°C
Grid Pass Transistor	41	150	°C
Grid Transformer	27	-	°C
Grid Load	30	-	°C

Table 13: Temperature Results after 10 minute test

### Testing Results

Testing of the Minitron was completed on 9 April 2009 at Bates lab. Zilu Zhou from SLB Inc. came to assist with the testing. After preparing the Minitron chamber as above, the power supplies were to be connected. Several portable multimeters were used to keep track of the currents running through each of the supplies. The Cathode supply was attached first, and run at 1.5A. As the Cathode heated up, the current dropped to around 1A.

The Grid supply was the next attached. Unfortunately, due to an operator error, the supply was connected over a 1 $\Omega$  load to ground, which destroyed the device. For the remainder of the Minitron testing, a commercial 200V supply was used. The Grid supply was set at 200V, and the current monitored. The Cathode current was then increased, slowly, until approximately 10mA of current was detected on the Grid supply. Over a period of approximately 5 minutes, the cathode current was increased from 1.5A to 2.52A. This transition needs to happen slowly because of the extreme temperatures reached by the Cathode. As the current is increased, the Cathode reaches temperatures exceeding 1000°C. In order to reduce any thermal shock, the current is increased slowly.

The current being observed on the Grid indicates that an electron beam has been established inside the Minitron. The next step is to apply current to the Filament. This will release low pressure deuterium gas, which will be ionized by the electron beam. Similarly to the Cathode, the Filament reaches extremely high temperatures, and needs to be slowly heated. The current is again set at 1.5A, and slowly raised to 2.0A. This value will be changed once the high voltage supply is turned on.

With the presence of ionized deuterium molecules in the device, the final step is to attach the high voltage supply. This provides the bias to accelerate the deuterium molecules into a deuterium target. When they collide, they release neutrons. The high voltage supply was turned on, and measured at 29.78kV. The Filament current was increased to 2.17A until a current of 120 $\mu$ A was read on the high voltage supply.

The detector, shown in below, began to detect neutrons.



**Figure 39: Neutron Detector registering Neutron Flux**

Gerry Fallon, the radiation officer at MIT Bates, recorded 0.5mRem / hour at 6 inches away from the Minitron, recorded at the center of the cylinder, and at the center of the tube. These radiation doses are not harmful to humans for short term exposure. This concluded a successful test of the Minitron.

Having recorded neutron generation, the Minitron was turned off. In order to do this, the high voltage supply was first turned off to stop the production of neutrons. Then, the Filament supply was reduced to 1A of current. Following this, the Cathode current was reduced to 1A of current. Finally, all of the supplies were disconnected, and the Minitron was thereby turned off.

## Chapter 4: Conclusions and Recommendations

Having completed the design, prototyping, and testing of the supplies and controllers, as well as successful neutron generation, one can make several comments about the success of this project, as well as ideas for future improvements.

### Conclusions

The over-arching goal of this project was to develop the entire front end electronics needed to operate a compact neutron source. There were three supplies made, the Grid, Cathode, and Filament. In addition controller board was designed to control a high voltage supply for the Minitron. The Grid supply supplied 200V at currents of up to 16mA, pulse width modulated at up to 1kHz. The Cathode and Filament supplies were identical, supplying up to 3A at 3V. The controller board specified an output of 30kV on a commercially available power supply. A custom housing was also designed for the Minitron to facilitate testing. Once all of these things were done, with the help of Zilu Zhou from Schlumberger, the Minitron was turned on, and neutron flux was observed. In all, this project was a success.

Although the Grid supply was destroyed before it could be connected to the Minitron, it had been tested in similar conditions, and we are confident that it would have functioned properly. Testing indicates that at 200V with a change from 2 $\mu$  to 20mA load, the maximum voltage change will be 0.035%. In addition, at an ambient temperature of 20°C, the junction temperature of the series pass transistor did not exceed 47.1°C. This is far below the requirement of 125°C. The electronic switch for the microcontroller functioned properly, quickly switching the 200V output on and off.

The Cathode and Filament supplies proved to be very stable during testing. Over the course of 10 minutes, the voltage over a 1 $\Omega$  load changed by 0.33%. This greatly exceeds the specification. The main drawback, however, is the power dissipation in the regulator. The regulator circuits designed have good efficiency 62.5% but still generate heat which need to be dissipated. Tests indicate that at 20°C ambient, the regulator junction temperature does not exceed 96.9°C at full power load. This is much



less than the 125°C maximum but still represents a considerable amount of heat, 5.4W, being generated. This is the tradeoff, however, of a linear design versus a switching design.

The high voltage controller worked perfectly, as would be expected from a precision high voltage supply. The output voltage was within 1% of the desired output voltage, and did not vary during testing. The current feedback pin reported a current with less than 1% error of the predicted current value. This current feedback pin was also extremely useful while testing the Minitron, as current being drawn from the HV supply indicated that D-D reactions were taking place.

## Recommendations

The Grid supply performs very well. Even at large currents, the output remains stable. Since this supply is dissipating such low power, thermal concerns are not nearly as important as with the Cathode or Filament designs. Even if a more efficient switching design existed which would not produce EMI, the simplicity and elegance of this design still makes it a viable choice. One possible design enhancement to improve switching speed if higher PWM frequencies are needed is to use an emitter switch as in Figure 27 on page 50. Another consideration would be to change the requirements of the supply to source current up to 100mA. Higher Grid current will allow for higher neutron flux, giving more flexibility to the operator.

Completing the testing under the guidance and supervision of Zilu Zhou gave us more insight into future design considerations for this project. During the design phase of the project, all of the supplies were designed to output a precise voltage. However, having run through the turn on procedure with Zilu Zhou and thereby learning more about how the Minitron functions, we recommend that future designs make use of a constant current regulator setup for the Cathode and Filament supplies. A current regulator setup as in Figure 16 on page 36 would allow the user to more easily select the operating currents on the Filament and Cathode. Because the resistance changes as the Filament and Cathode

heat up, when the user wishes to adjust the current he/she must constantly adjust the voltage to keep the same current while the resistance settles. Using a current regulator topology would eliminate this nuisance.

In addition, because we were more concerned about measuring voltages than currents, the Minitron test set up needed to be changed on the day of testing, using 4 multimeters to measure various currents. Since during operation it is impractical to have several multimeters to measure the outputs, a better solution would be to include digital panel meters to read the output current. There are many inexpensive digital panel meters which can be programmed to display the output current on each of the supplies. These would be very useful for the Grid, Cathode, and Filament supplies. In addition, this would reduce the number of stray wires in the test area considerably. With panel meters the power supply will be able to be completely enclosed while running without any additional test equipment attached.

It is also suggested to make the Grid supply variable from 100V to 200V. The current design allows for slight variation due to the trim potentiometer used to fine tune adjust the supply. However, the ability to vary the Grid supply will allow the operator to control the electron beam, and thus the ionization of the deuterium. A simple change like this will make the supply more robust, and offer greater options to the end user.

During the test setup an on-off switch was made by using a power strip with an on-off switch to interrupt the AC power. Individual on-off switches for each of the 3 supplies would be useful when turning the Minitron on. A master on-off switch for all of the power supplies would increase the safety of the device. In addition, adding interlocks or remote kill switches to conform to SNOLAB safety procedures or recommendations will make the supply safer. With these experiments, safety is the top

priority; adding extra safety features will improve how people interact with the device and prevent possible injury or death.

For future designs, MIT should investigate the feasibility using a different high voltage supply. SLB Inc. operates the Minitron at voltages in excess of 100kV. This increases the neutron flux and allows for more flexibility while operating the Minitron. In addition, the controller should be designed to accommodate a varying HV output. It is our opinion that attempting to design a new high voltage supply would not be justified. The inexpensive price of high quality power supplies available does not justify the engineering time to develop a high voltage supply, especially since the current feedback is necessary.

While the supplies designed function well now, the improvements recommended will increase the usability of the device in the future should future revisions be made.

## Works Cited

1. Freeman, K., McNamara, G., *In Search of Dark Matter*, Birkhäuser: 2006.
2. General presentation of the EDELWEISS experiment, Edelweiss-II Presentation:  
<<http://edelweiss.in2p3.fr/Presentation/index.php>>. Retrieved 18 Apr. 2009.
3. Clara Moskowitz, *Live Science*, "Mysterious Dark Matter Possibly detected":  
<<http://www.livescience.com/space/090401-dark-matter-annihilation.html>>. Posted 1 Apr. 2009, Retrieved 18 Apr. 2009.
4. Other Dark Matter Experiments, Cryogenic Dark Matter Search:  
<<http://cdms.physics.ucsb.edu/others/others.html>>. Retrieved 18 Apr. 2009.
5. Research and Development, Schlumberger, Schlumberger Inc:  
<<http://www.slb.com/content/about/researchanddevelopment.asp?>>. Retrieved 18 Apr. 2009.
6. McKinsey, D., *Mini-CLEAN and DEAP/CLEAN Detectors*, Yale University Physics Department, 7 Jun 2007: <[http://mckinseygroup.physics.yale.edu/Publications/McKinsey\\_DSU.pdf](http://mckinseygroup.physics.yale.edu/Publications/McKinsey_DSU.pdf)>. Retrieved on 19 Apr. 2009.
7. Chen et al., *Neutron Generator*, United States Patent 5,293,410. Granted 8 Mar. 1994.
8. Lenk, John D., *Simplified Design of Switching Power Supplies*, Butterworth-Heinemann, Boston: 1995.
9. Lenk, John D., *Simplified Design of Linear Power Supplies*, Butterworth-Heinemann, Boston: 1994.
10. *Simple active method for reducing magnetic interference in a thermoelectrically cooled photomultiplier tube*, Petri Karha and Teemu Jaakkola, Rev. Sci. Instrum. 79, 043102 (2008), DOI:10.1063/1.2906317
11. 7.5A, 5A, 3A Low Dropout Positive Adjustable Regulators Datasheet (LT1083/LT1084/LT1084), Linear Technology, Revision F, Linear Technology, 1994.

12. 5A Low Dropout Positive Adjustable or Fixed Mode Regulator Datasheet (AP1084), Diodes Inc., Revision 7, Diodes Inc. March 2009.
13. *High voltage Adjustable Power Supplies*, Micheal Maida, National Semiconductor Linear Brief 47, March 1980.
14. 3-Terminal Adjustable Regulator (LM117/LM317A/LM317), National Semiconductor, National Semiconductor Revision 9063 20 Oct. 2008.
15. High Input Voltage, Adjustable 3-Terminal Linear Regulator Datasheet (LR8), Supertex Inc., Supertex Inc. Document # DSFP-LR8, Version A091205, 2008.
16. *A Solid-State Filter Choke or Field Coil Replacement*, Ken Owens, Antique Wireless OTB: <<http://www.antiquewireless.org/otb/resto0504.htm>>. Retrieved 3 Feb. 2009.
17. Hambley, Allan R., *Electrical Engineering: Principles and Applications*, Pearson Prentice Hall, Upper Saddle River, N.J.: 2008.
18. Thompson, Marc T, *Intuitive Analog Circuit Design*, Elsevier, Boston: 2006.
19. NPN Epitaxial Silicon Transistor (2SC3503/KSC3503) Datasheet, Fairchild Semiconductor, Fairchild Semiconductor Revision A1, 2008.
20. File:DA-15 DSubM.png, Wikipedia Image: <[http://en.wikipedia.org/wiki/File:DA-15\\_DSubM.png](http://en.wikipedia.org/wiki/File:DA-15_DSubM.png)>. Retrieved 18 Apr. 2009.
21. "thermal neutron". (2009). In *Encyclopædia Britannica*. Retrieved April 21, 2009, from Encyclopædia Britannica Online: <<http://www.britannica.com/EBchecked/topic/591449/thermal-neutron>>.

## Appendix A: High Voltage Power Supply Datasheet

# TOF3000

## MASS SPECTROMETRY POWER SUPPLY

SPELLMAN HIGH VOLTAGE ELECTRONICS CORPORATION

PAGE 1 OF 2



- **REMOTE OUTPUT POLARITY REVERSIBILITY VIA TTL SIGNAL CONTROL**
- **ULTRA LOW RIPPLE AND NOISE**
- **SMALL FOOTPRINT OEM MODULAR PACKAGING**
- **ENCAPSULATED FOR RELIABLE, LONG TERM CORONA FREE OPERATION**
- **CE COMPLIANT**

The TOF3000 offers critical specifications like ultra low ripple and noise, excellent temperature coefficient; a stable, repeatable and accurate output, along with remote output polarity reversing capability. These superior specifications result in improved mass spectrometer resolution. Unique high voltage packaging and surface mount fabrication techniques, coupled with Spellman's proprietary encapsulation technology provide this unit in an attractive sized OEM package.

Featuring a 0-30kV @ 400 $\mu$ A output with remote polarity reversing capability and dimensions of 3"H x 5"W x 12.58"L, the TOF3000 is a small, cost-effective high voltage power supply with technology that sets the standard for the future of Mass Spectrometry applications.

### TYPICAL APPLICATIONS

Mass Spectrometry

### SPECIFICATIONS

**Input Voltage:**  
+24 Vdc, +5%, -2%

**Input Current:**  
2 amps maximum

**Output Voltage:**  
0 to 30kV

**Output Current:**  
0 to 400 microamperes

**Polarity:**  
Positive or Negative with respect to ground, reversible via TTL signal

**Voltage Regulation:**  
Line: 0.001% for input change of 1 volt  
Load: 0.001% for 100 $\mu$ A to full load change

**Current Regulation:**  
Line: 0.05% for +5% to -2% input change  
Load: 0.1% for 0 to maximum output voltage

**Ripple:**  
 $\leq 70$ mV peak to peak

**Stability:**  
0.01% per hour, 0.02% per 8 hours after 1.0 hour warm up period

**Temperature Coefficient:**  
100ppm per degree C (improved capabilities upon request)

**Environmental:**  
Temperature Range:  
Operating: 0°C to 50°C  
Storage: -20°C to 65°C  
Humidity:  
10% to 90% RH, non-condensing

### Control Interface

**Voltage Program Input:**  
0 to +10Vdc corresponds to 0 to  $\pm 30$ kV,  $Z_{in} \geq 1$  megohm

**Program Accuracy:**  
 $\pm 0.15\%$  at 15KV, with overall accuracy of  $\pm 0.25\%$  of maximum output

**TTL Polarity Reversal:**  
High = positive polarity  
Low = negative polarity

**Voltage Monitor:**  
0 to 10Vdc corresponds to 0 to 30KV,  $Z_{out} = 4.7$ Kohm

**Current Monitor:**  
0 to 10Vdc corresponds to 0 to 400 $\mu$ A,  $Z_{out} = 4.7$ Kohm

**Cooling:**  
Convection cooled

**Dimensions:**  
3"H X 5"W X 12.625"D (70.62mm x 127mm x 321.7mm)

**Weight:**  
9.5 pounds (4.31kg)

**Interface Connector:**  
15 pin male D connector

**Output Connector:**  
Alden B102, which accepts Alden B200 cable plug



USA +1-831-630-3000  
UK +44 (0)1798 877000  
JAPAN +81 (0)48-447-8500  
CHINA +86 (0)512-67630010

FAX: +1-831-435-1620  
FAX: +44 (0)1798 872479  
FAX: +81 (0)48-447-8501  
FAX: +86 (0)512-67630030

e-mail: sales@spellmanhv.com  
www.spellmanhv.com

129032-001 REV.C

Spellman High Voltage is an ISO 9001:2008 and ISO 14001:2004 registered company

## Appendix B: SPICE model for LT1084 regulator

Retrieved from:

<http://www.linear.com/pc/downloadDocument.do?navId=H0,C1,C1003,C1040,C1055,P1282,D11656>

On 13 April 2009

\* Version 2.0 Copyright  Linear Technology Corp. 10/19/04. All rights reserved.

\*

\*CCM Fri May 15 11:42:15 1998

\*

\* ADJ OUT IN

.SUBCKT LT1084 1 2 3

\*

\* power section

\* power transistor

QPWR 41 42 43 Q1

RBASE 42 43 1.0E3

RDROP 43 2 0.055 TC=-6.0E-3

VCURR 3 41 DC 0

QDRV 42 44 41 Q2

RDRV 50 44 5.0E4

\* current limit with SOA protection

\* 6.5A limiter

HCL1 15 0 VCURR 0.128

DCL1 15 16 DX

VCL1 16 21 DC 0

FCL1 0 50 VCL1 5.0E2

\* SOA protection

\* P0 of GCL1defines threshold1 / knee voltage1

\* RCL2 defines decay factor

GCL1 0 17 POLY(1) 3 2 -6.0E-3 1.0E-3

RCL1 0 17 1.0E3

DCL2 17 18 DX

RCL2 18 0 50E3

\* square characteristic

\* VCL2 defines lower limit resp. second knee voltage

GCL2 0 19 POLY(1) 18 0 0 0 1.0E-4

RCL3 19 0 1.0E3

DCL3 19 20 DX

VCL2 20 0 DC 17.8

ECL1 21 0 19 0 -0.0406

\* error amplifier

\* amplifier with 80 dB gain

GEA2 0 50 2 7 32.0

REA2 50 0 1.0E3

DEAP 50 51 DX

EEAP 51 0 POLY(1) 3 0 -0.9 1.0

DEAN 52 50 DX

VEAN 52 0 DC 0.9

\* feedback for transient response

RF 50 55 10

CF 55 7 24.4E-11

\* adjust pin current

GADJ1 0 8 2 1 4.4e-5

```
RADJ 8 0 1.0E6 TC=0.003
GADJ2 3 1 8 0 -1.0E-6
* voltage reference (1.250V)
* 1.250V reference
* no temperature drift required as curve swings around 1.25V
IREF1 1 7 DC 0.00125
RREF1 7 1 1.0E3
* load regulation (Iload: 10mA -> 5.0A / -60 mV at 10V output)
FLOAD 7 1 VCURR 1.45E-6
* models used
.MODEL DX D IS=8e-16 RS=0 XTI=0
.MODEL Q1 NPN IS=1e-14 BF=450 RC=0 RE=0 XTI=0
.MODEL Q2 PNP IS=1e-16 BF=625 RC=0 RE=0 XTI=0
.ENDS LT1084
```



## Appendix C: TIP50 Transistor Data Sheet



**FAIRCHILD**  
SEMICONDUCTOR

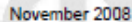

### TIP47/TIP48/TIP49/TIP50

#### NPN Silicon Transistor

- High Voltage and Switching Applications
- High Sustaining Voltage :  $V_{CEO(sus)} = 250 - 400V$
- 1A Rated Collector Current



TO-220

1.Base 2.Collector 3.Emmitter

---

**Absolute Maximum Ratings\***  $T_s = 25^\circ C$  unless otherwise noted

Symbol	Parameter	Rated	Units
$V_{CBO}$	Collector-Base Voltage	: TIP47	350
		: TIP48	400
		: TIP49	450
		: TIP50	500
$V_{CEO}$	Collector-Emmitter Voltage	: TIP47	250
		: TIP48	300
		: TIP49	350
		: TIP50	400
$V_{EBO}$	Emmitter-Base Voltage	5	V
$I_C$	Collector Current (DC)	1	A
$I_{CP}$	Collector Current (Pulse)	2	A
$I_B$	Base Current	0.6	A
$P_C$	Collector Dissipation ( $T_C=25^\circ C$ )	40	W
	Collector Dissipation ( $T_s=25^\circ C$ )	2	W
$T_J$	Junction Temperature	150	$^\circ C$
$T_{STG}$	Storage Temperature	-65 ~ 150	$^\circ C$

\* These ratings are limiting values above which the serviceability of any semiconductor device may be impaired.

© 2007 Fairchild Semiconductor Corporation  
TIP47/TIP48/TIP49/TIP50 Rev. 1.0.0
www.fairchildsemi.com

TIP47/TIP48/TIP49/TIP50 — NPN Silicon Transistor

Electrical Characteristics* $T_a = 25^\circ\text{C}$ unless otherwise noted						
Symbol	Parameter	Test Condition	Min.	Typ.	Max.	Units
$V_{CEX(sus)}$	Collector-Emitter Sustaining Voltage	$I_C = 30\text{mA}, I_B = 0$	250			V
	: TIP47					
	: TIP48					
	: TIP49					
	: TIP50	400			V	
$I_{CEO}$	Collector Cut-off Current	: TIP47	$V_{CE} = 150\text{V}, I_B = 0$		1	mA
		: TIP48	$V_{CE} = 200\text{V}, I_B = 0$		1	mA
		: TIP49	$V_{CE} = 250\text{V}, I_B = 0$		1	mA
		: TIP50	$V_{CE} = 300\text{V}, I_B = 0$		1	mA
$I_{CEX}$	Collector Cut-off Current	: TIP47	$V_{CE} = 350\text{V}, V_{BE} = 0$		1	mA
		: TIP48	$V_{CE} = 400\text{V}, V_{BE} = 0$		1	mA
		: TIP49	$V_{CE} = 450\text{V}, V_{BE} = 0$		1	mA
		: TIP50	$V_{CE} = 500\text{V}, V_{BE} = 0$		1	mA
$I_{EBO}$	Emitter Cut-off Current	$V_{EB} = 5\text{V}, I_C = 0$			1	mA
$h_{FE}$	* DC Current Gain	$V_{CE} = 10\text{V}, I_C = 0.3\text{A}$	30		150	
		$V_{CE} = 10\text{V}, I_C = 1\text{A}$	10			
$V_{CE(sat)}$	* Collector-Emitter Saturation Voltage	$I_C = 1\text{A}, I_B = 0.2\text{A}$			1	V
$V_{BE(sat)}$	* Base-Emitter Saturation Voltage	$V_{CE} = 10\text{V}, I_C = 1\text{A}$			1.5	V
$f_T$	Current Gain Bandwidth Product	$V_{CE} = 10\text{V}, I_C = 0.2\text{A}, f = 1\text{MHz}$	10			MHz

\* Pulse Test: Pulse Width 300 $\mu$ s, Duty Cycle 2%

TIP47/TIP48/TIP49/TIP50 — NPN Silicon Transistor

**Typical Characteristics**

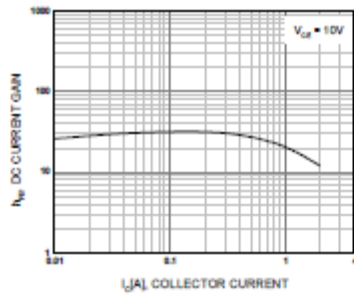

Figure 1. DC current Gain

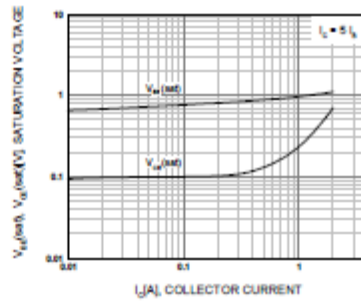

Figure 2. Collector-Emitter Saturation Voltage  
Base-Emitter Saturation Voltage

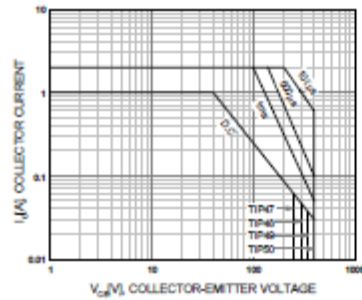

Figure 3. Safe Operating Area

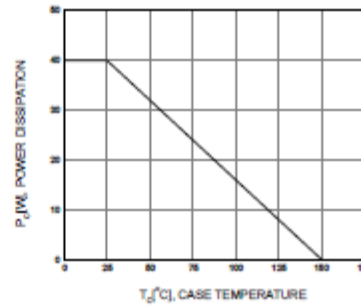

Figure 4. Power Derating



## Appendix D: Proposal for Neutron Source

### A Compact Pulsed Neutron Source for Dark Matter and Neutrinoless Double Beta Decay Experiments

J. A. Formaggio

*Laboratory for Nuclear Science  
Massachusetts Institute of Technology  
Cambridge, MA 02139*

(Dated: April 22, 2008)

#### I. MOTIVATION

The arch-type of experiments typically labeled as "rare event experiments" –such dark matter experiment and neutrinoless double beta decay experiments– vary greatly in the detection techniques employed, materials used as targets, and ultimate sensitivity to their respective signatures. Yet, despite these wide differences between these experiments, they all possess certain common features; mainly, (a) they require unprecedented levels of cleanliness, particularly in uranium and thorium levels, in the materials surrounding their active volume and (b) require extreme depths in order to substantially reduce the backgrounds from high energy cosmic rays that might be mis-reconstructed as a genuine signal event. The latter is especially true for experiments that are sensitive to neutron recoils, since high energy neutrons are often produced from cosmic ray interactions taking place in the rock surrounding a given experiment. Dark matter experiments and neutrinoless double beta decay ( $0\nu\beta\beta$ ) experiments fall in this category [1]. The flux of these high energy neutrons is difficult to predict a priori and often difficult to shield. It is imperative, therefore, that a given dark matter or neutrinoless double beta decay experiment understand its response to recoils from neutrons, both to help characterize the detector response to a potential signal, as well as to test the experiment's effectiveness in reducing this undesired background. Some experiments make use of radioactive sources, such as Am-Be, as their neutron calibration source. However, these sources provide a continuous source of neutrons with a wide energy spectrum. Characterizing a detector's response to this spectrum, therefore, becomes difficult. Radioactive sources also introduce a certain element of risk, since they can contaminate an

2

ultra-clean detector if proper precautions are not taken. Other experiments make use of commercial deuterium-tritium (D-T) sources, but such sources are often very large and are not easily deployable into the fiducial volume of a given experiment.

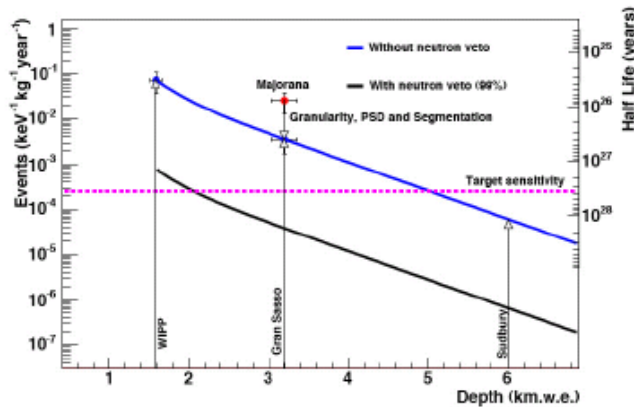
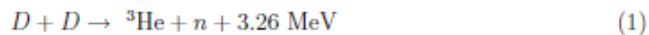

FIG. 1: The depth-sensitivity relation derived for a Majorana-like experiment showing, specifically, the results from this work assuming the detector is operated at a depth equivalent to the Gran Sasso Laboratory. The upper curve displays the background simulated in the case that no active neutron veto is present and the lower curve indicates the reduction that would ensue if an active neutron veto were present that is 99% efficient. Figure taken from Ref. [1].

We propose designing and constructing a compact, non-radiologic, low cost neutron source, capable of delivering up to  $\approx 10^5$  neutrons per second. The source works as a miniature D-D accelerator, whereby deuterium ions are accelerated against a titanium source, also plated with deuterium. The reaction:



delivers a 1-ms long pulse of isotropic neutrons at the energy range that is of most interest for recoil-sensitive experiments. The source's compactness allows for deployment in the fiducial volume of the detector, and the absence of any inherent radiological material reduced the risk of potential contamination of the experiment. Since the source is electrostatic in nature, it allows for user control of the calibration source. Such a pulsed neutron source would not

limited to dark matter or  $0\nu\beta\beta$  experiments. Other rare search experiments designed as part of the Deep Underground Science Laboratory, such as solar neutrino experiments, can also benefit from such a compact calibration source.

## II. PULSED NEUTRON SOURCE DESIGN

If one wishes to design a pulsed generator as a source for neutrons, there are three reactions one can consider:

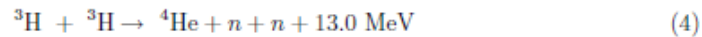

The first two reactions provide a narrow-band spectrum of neutrons escaping from the reactions, while the latter provides a flat "white-noise" energy spectrum. Though all three reactions are of interest for rare underground experiments, here we consider simply reaction (2). This removes some of the complications associated with the handling gaseous tritium sources.

Figure 2 shows the cross-section for  $\text{D}(\text{d},\text{n}){}^3\text{He}$  and  $\text{D}(\text{t},\text{n}){}^3\text{He}$  reactions as a function of center-of-mass energy. Although the cross-section is maximal for  $\text{D}(\text{t},\text{n}){}^3\text{He}$  at 100 keV, there is still some appreciable cross-section for the reaction, even as low as 20 keV. For most rare event applications, only small fluxes –on the order of  $10^3 - 10^4$  n/s– are needed for background tagging and signal calibration. Such fluxes are suitable for most dark matter and neutrinoless double beta decay applications.

We propose to build a compact neutron source based on the D+D nuclear reaction, small enough to be suitable for calibration of dark matter and neutrinoless double beta decay experiments. Compactness has a considerable advantage over conventional D+D and D+T sources, since they can readily be inserted inside or near the fiducial volume of the detector. By operating these D+D devices near 20 keV, the resulting neutron spectrum is very narrow, near 2.5 MeV. This approach has the advantage of being able to mimic common backgrounds such as  $(\alpha, n)$  reactions present in photomultiplier tube glass or, in the case of dark matter

4

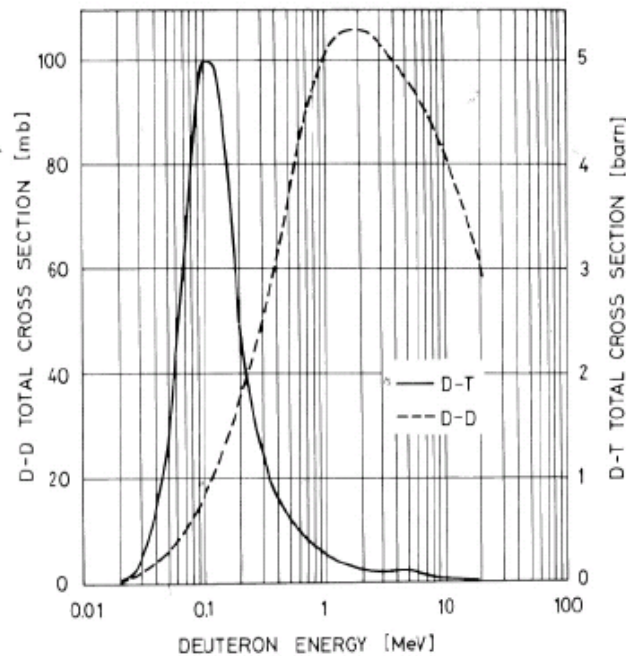

FIG. 2: Cross-section for the  $D(d,n)^3\text{He}$  (dashed) and  $D(t,n)^3\text{He}$  (solid) reactions as a function of center-of-mass energy.

experiments, replicating the actual recoil signal (see Fig. 3). We wish to apply to approach this source with two different schemes:

1. **Cold Cathode Ion Method** In this method, the deuterium ions responsible for the  $D+D$  reaction are generated via field emission. A small Ti-coated needle held at high potential should provide sufficient field strengths to ionize any deuterium deposits on the surface. The resulting deuterium ions would accelerate across a 20 kV gap against a deuterium-doped anode. By pulsing the 20 kV potential, it will be possible to create a controlled pulse of neutrons. To minimize x-ray production from secondary electrons and to localize the ion beam against the anode target, a magnetic field can be applied to the volume. It is possible to use permanent magnets can create strong fields with very little structure overburden.
2. **Hot Cathode Ion Method** In this method, the deuterium ions are provided from a



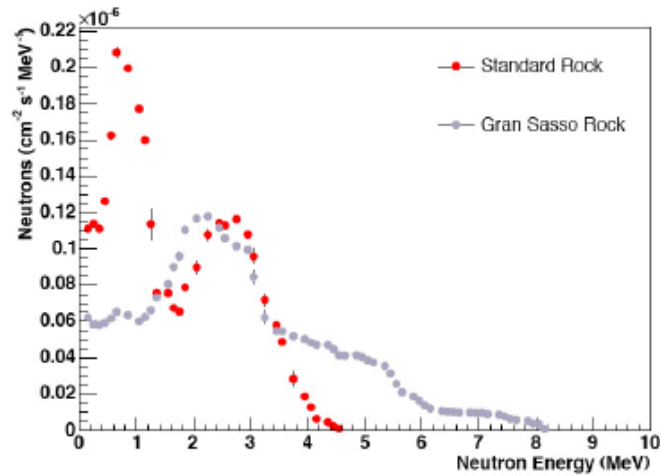

FIG. 3: The neutron energy spectrum arising from  $(\alpha, n)$  reactions due to radioactivity in standard rock (grey) and Gran Sasso rock (red). Figure taken from Ref. [1].

pulse of electrons created from a heated filament. Schlumberger Inc. already manufactures such miniature sources for oil exploration research [2] and has graciously agreed to provide a loan of one of their compact neutron sources for use in the DEAP dark matter experiment. As the technology to make such units is proprietary, no attempt will be made to replicate their methodology. R&D funds are sought mainly for the control electronics.

One aspect that is common to both techniques is the high voltage control mechanism used to control these units. A small 20 kV pulsing circuit would be made in order to pulse either neutron source. Recent advances in high voltage diodes makes it possible to create push-pull circuits with voltage potentials up to 50 kV. A circuit similar to that described in Ref. [3] would be used here.

Monitoring of the stability and performance of the pulsed neutron source would be achieved by both monitoring the current draw on the high voltage circuit and via neutron production. The former would be part of the control electronics, while the latter would make use of existing  $^3\text{He}$  proportional counters that the PI currently has in his possession.

### III. COST ESTIMATE

Table I articulates the anticipated costs for the neutron pulsed source. This project would be ideal for an undergraduate student to partake over the course of the 3 month program. Summer salary for one student is thus included in the final cost estimate.

TABLE I: Estimated cost for pulsed neutron source. Overhead is included as part of the cost estimate.

Item	Cost
Miniature high voltage supply	\$2.3 k
Control Electronics	\$1.7k
Machining costs	\$ 1k
Gas and gas ports	\$ 1k
Monitoring electronics	\$2k
Undergraduate student	\$ 5k
Total Cost	\$12 k

---

[1] D-M. Mei and A. Hime, ArXiv:astro-ph/0512125 (2005).

[2] F. Chen and A. Liberman, U.S. Patent No. 5,293,410. Washington, DC: U.S. Patent and Trademark Office (1991).

[3] J. Hansknecht, "Using Opto-Couplers in a High Voltage Push-Pull Configuration", J-Lab internal note.

# Appendix E: Minitron Patent (U.S. Patent #5,293,410)



US005293410A

**United States Patent** [19]

[11] **Patent Number:** 5,293,410

Chen et al.

[45] **Date of Patent:** Mar. 8, 1994

[54] **NEUTRON GENERATOR**

[75] **Inventors:** Felix K. Chen, Newtown; Arthur D. Liberman, Ridgefield, both of Conn.

[73] **Assignee:** Schlumberger Technology Corporation, Houston, Tex.

[21] **Appl. No.:** 754,842

[22] **Filed:** Sep. 4, 1991

[51] **Int. Cl.:** G21B 1/00

[52] **U.S. Cl.:** 376/108; 376/114

[58] **Field of Search:** 376/108, 114, 109

**References Cited**

**U.S. PATENT DOCUMENTS**

2,543,728	7/1948	Lemmens et al.	313/337
2,750,527	11/1952	Katz	313/346
3,276,974	10/1966	Tyson	204/32
3,490,944	1/1970	Almer et al.	117/217
3,546,512	12/1970	Frentrop	376/108
3,756,682	9/1973	Frentrop	376/108
3,775,216	11/1973	Frentrop	376/108
4,007,393	2/1977	Van Stratum et al.	313/346 R
4,165,473	8/1979	Falce	313/346 R
4,600,838	7/1986	Steinman et al.	250/270
4,721,853	1/1988	Wraight	250/269
4,794,792	1/1989	Flaum et al.	73/152
4,996,017	2/1991	Ethridge	376/116

**OTHER PUBLICATIONS**

Penning and Moubis, "A neutron tube without pumping system," *Physica* 4, (1937).

Chen, "Investigation of the striking characteristics of a Penning ion source," *Journal of Applied Physics*, 56 (11), Dec. 1, 1984, pp. 3191-3197.

Ethridge et al., "Neutron generators for Wireline application," 1990 *IEEE Nuclear Science Symposium Conference Record*, Arlington, Va., Oct. 22-23, 1990, vol. 2, pp. 820-824.

Scott, "Focused beam source of hydrogen and helium ions," *Phys. Rev.*, vol. 55, May 15, 1939, pp. 954-959.

Wood and Crocker, "An electrostatically focused ion source and its use in a sealed off DC neutron source," *Nuclear Instruments and Methods*, 21 (1963), pp. 47-48.

Dworetzky et al., "Electron bombardment ion source for low energy beams," *Review of Scientific Instruments*, vol. 39, No. 11, Nov. 1968, pp. 1721-1723.

Kohl, *Materials and Techniques for Electron Tubes*, Reinhold Publishing, 1960, pp. 519-566.

Forman, "Surface studies of barium and barium oxide on tungsten and its application to understanding the mechanism of operation of an impregnated tungsten cathode," *Journal of Applied Physics*, vol. 47, No. 12, Dec. 1976, pp. 5272-5279.

Falce, "A cavity reservoir dispenser cathode for CRT's and low-cost traveling-wave tube application," *IEEE Transactions on Electron Devices*, vol. 36, No. 1, Jan. 1989, pp. 169-172.

Marrion and Shih, "Operation of coated tungsten based dispenser cathodes in nonideal vacuum," *IEEE Transactions on Electron Devices*, vol. 36, No. 1, Jan. 1989, pp. 173-179.

Hawkins and Sutton, "Compact pulsed generator of fast neutrons," *Review of Scientific Instruments*, vol. 31, No. 3, Mar. 1960, pp. 241-248.

Hall et al., "Improvements in pulsed neutron capture logging," *IEEE Transactions on Nuclear Science*, vol. NS-28, No. 2, Apr. 1981, pp. 1680-1684.

*Primary Examiner*—Donald P. Walsh  
*Assistant Examiner*—Frederick H. Voss  
*Attorney, Agent, or Firm*—Leonard W. Pojunas

[57] **ABSTRACT**

A neutron generator, comprising:

- (i) an ion source comprising an anode and a thermionic cathode disposed in an ionizable gas environment (e.g. hydrogen isotope);
- (ii) means for heating the cathode so that the latter emits electrons which, when colliding with the gas atoms, generate ions;
- (iii) a target;
- (iv) an electrical gap to accelerate ions from the ion source towards the target upon impingement of the ions; and
- (v) control means for applying voltages to the anode, cathode and electrical gap.

The cathode is of the dispenser type or volume type, and preferably comprises one block of material comprised of a substrate impregnated with an electron emitting material.

39 Claims, 3 Drawing Sheets

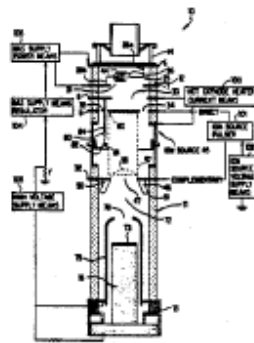

U.S. Patent

Mar. 8, 1994

Sheet 1 of 3

5,293,410

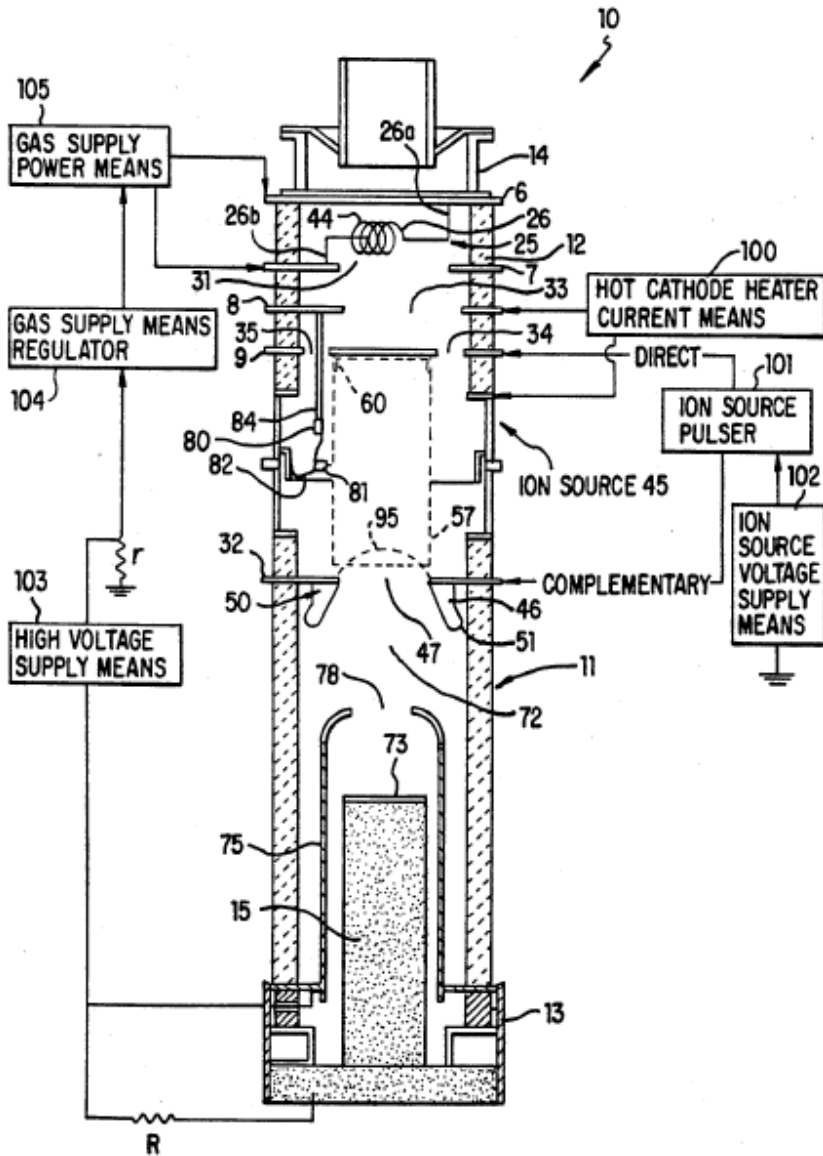

FIG. 1

U.S. Patent

Mar. 8, 1994

Sheet 2 of 3

5,293,410

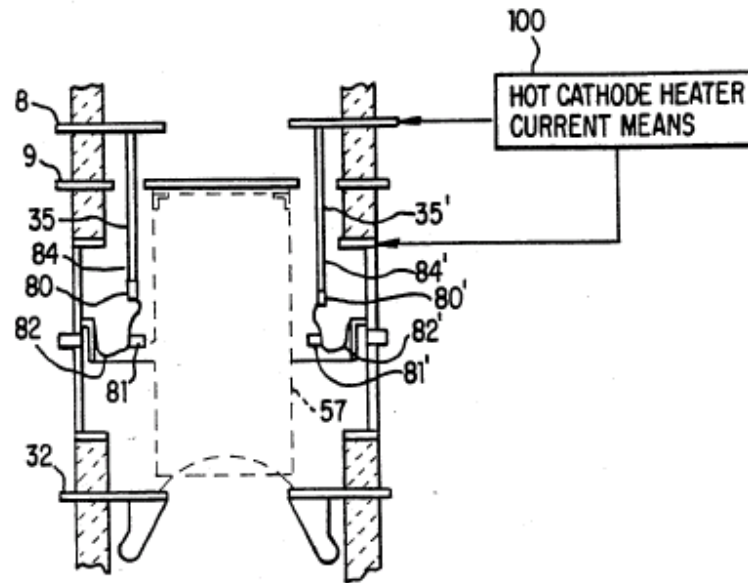

FIG. 2A

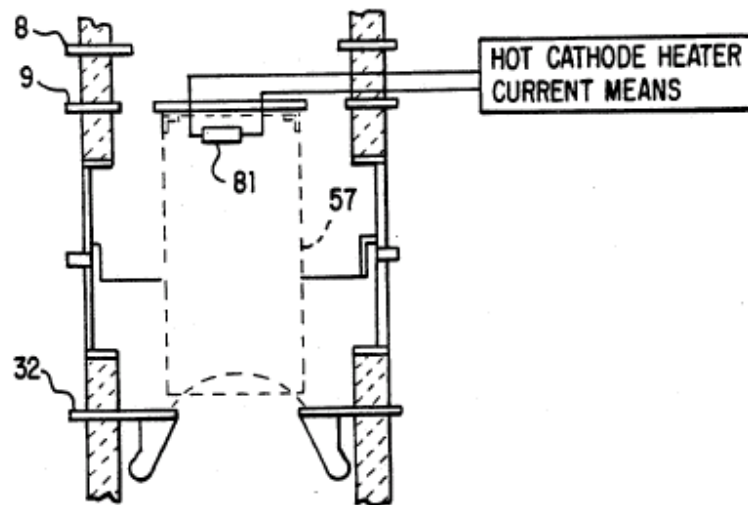

FIG. 2B

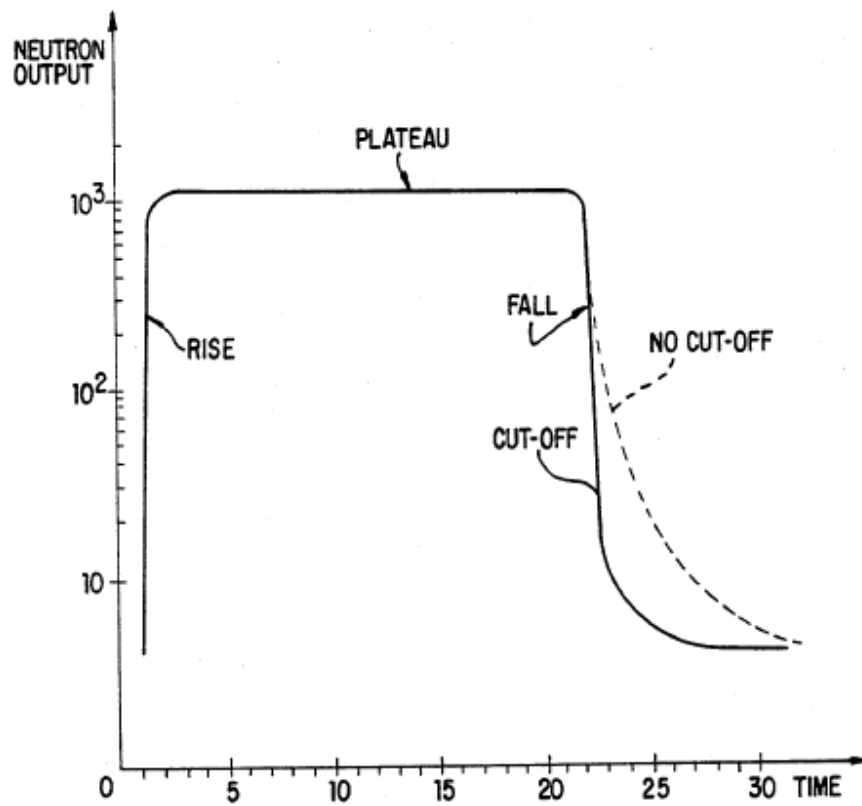

FIG. 3



5,293,410

1

## NEUTRON GENERATOR

## BACKGROUND OF THE INVENTION

## 1. Field of the Invention

This invention relates to neutron generating systems and more particularly pertains to a new and improved neutron generator especially adapted to traverse the narrow confines of a well or borehole, although useful in a variety of other applications. Since a neutron generator embodying the invention is ideally suited to the needs of well logging services, it will be described in that connection.

## 2. The Related Art

The use of a generator of high energy neutrons has been known for a long time for neutron-gamma ray or neutron-neutron logging. A neutron generator has advantages compared with chemical neutron sources, in particular it features a negligible amount of radiation other than the desired neutrons; a high yield of neutrons; a controllable yield of neutrons in bursts or continuously; neutrons at higher energies than formerly possible; mono-energetic neutrons; and control of the generator so as to permit its deactivation prior to withdrawal from or insertion in a well. The first five of these attributes are important in obtaining more informative logs, while the last is valuable in minimizing health hazards to operating personnel.

Neutron generators used in oil well logging tools usually require controlled low pressure atmospheres and high intensity magnetic fields. Accordingly, for illustrative purposes, the invention is described in more complete detail in connection with a neutron generator suitable for use in a well logging tool.

Neutron generators usually have three major features:

- (i) a gas source to supply the reacting substances, such as deuterium ( $H^2$ ) and tritium ( $H^3$ );
- (ii) an ion source comprising usually at least one cathode and an anode; electrons are emitted from the cathode surface when an electrical impulse is applied to the anode; impact of the primary electrons on the gas molecules result in subsequent secondary electrons being stripped from the gas molecules, thus generating positively charged ions; and
- (iii) an accelerating gap which impels the ions to a target with such energy that the bombarding ions collide with deuterium or tritium target nuclei in neutron (n) generating reactions:

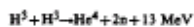

where  $He^3$  and  $He^4$  are helium isotopes, and the energy is expressed in millions of electron volts (MeV).

Ordinarily, negative electrons and positively charged ions are produced through electron and uncharged gas molecule collisions within the ion source. Electrodes of different potential contribute to ion production by accelerating electrons to energy higher than the ionization threshold. Collisions of those energetic electrons with gas molecules produce additional ions and electrons. At the same time, some electrons and ions are lost to the anode and cathode. In this manner, the positive and negative charges inside the ion source approach an

2

equilibrium. Collision efficiency can be increased by lengthening the distance that the electrons travel within the ion source before they are neutralized by striking a positive electrode. One known path lengthening technique establishes a magnetic field which is perpendicular to the aforementioned electric field. The combined magnetic and electrical fields cause the electrons to describe a helical path within the ion source which substantially increases the distance traveled by the electrons within the ion source and thus enhances the collision efficiency of the device.

This type of ion source, called "Penning ion source", is part of a family of "cold cathode ion sources" and has been known as early as 1937; see for example the article by F. M. Penning and J. H. A. Moubis in *Physica* 4 (1937) 1190. Examples of neutron generators including such "cold cathode ion source" used in logging tools are described e.g. in U.S. Pat. No. 3,546,512 or 3,756,682 both assigned to Schlumberger Technology Corporation.

However, neutron generators using Penning ion sources used in logging tools suffer from several drawbacks.

First, the anode being at a high potential, in the range of 1 to 3 kV, the cathode suffers erosion due to energetic ion bombardment. Material sputtered from the cathode may coat the insulator surfaces provided for electrical insulation either of the anode or of the target. This may cause instability which is prejudicial to the operation of the ion source. Also, this instability occurring in a space where high voltages are involved can be detrimental to safety.

Second, most logging nuclear measurements are carried out by emitting pulses of neutrons which irradiate the earth formations, and by detecting the radiation (neutrons or gamma rays) resulting from the interaction of earth formation atoms and the emitted neutrons. Thus, it is critical to have a good knowledge of the characteristics of the neutron pulse, such as the neutron output (number of neutrons emitted) and the pulse timing. Such knowledge means having control over these characteristics. It is highly desirable to generate neutron pulses having a substantially square shape, in particular a short rise time (to reach the plateau value) and a short fall time (once the voltages are turned off). However, in a Penning source, such tasks are difficult because the charge populations in the source, particularly the electron population, do not reach equilibrium instantaneously; see F. Chen, *J. Appl. Phys.* 56 (11) 3191, 1984. The rate at which the charge populations approach the equilibrium depends strongly on the gas pressure in the source. This effect manifests itself in the slow rise time of the neutron pulse, and a delay, typically a few microseconds (although sometimes variable with operation conditions), between the time the voltage appears at the anode and the start of the neutron pulse. Since the cathode and anode surface conditions are not identical between different neutron tubes, different pressures are often required to achieve the same neutron output. This makes the timing control of the source all the more difficult that it is essentially a function of the particular neutron generator, and may vary over the operating lifetime of the neutron generator.

Third, the high voltage required for a Penning ion source (1-3 kV) is generally produced via a pulse transformer. The transformers are designed for a certain pulse width. Thus, changing pulse length results in

5,293,410

3

altering the performance, most noticeably, the neutron pulse shape. There have been some attempts to improve the neutron pulse shape generated from a cold cathode ion source. In particular, the article "Neutron Generators for Wireline Application," from R. Ethridge et al., 1990 IEEE Nuclear Science Symposium Conference Record, Arlington, Va., Oct. 22-23, 1990, Vol. 2 of 2, describes a cold cathode source wherein the pulse transformer is provided with a "clamping" circuit designed to decrease the fall time of the pulse. However, such clamping circuits: (i) do not seem to improve the rise time of the neutron pulse; (ii) require additional power; (iii) and increase the overall size of the control circuit.

Fourth, the known cold cathode sources can usually operate in any one of several discharge modes according to the relative ion and electron populations and different plasma sheath structures. The anode voltage, the magnetic field and the gas pressure determine the operating point at which the production and loss of electrons and ions are at balance. In addition, under certain conditions, the operating point is unstable near certain mode boundaries. The transition from one mode to the other can lead to a substantial change in the ion beam density and electron extraction efficiency, and, with control circuits currently used that regulate the beam current by lowering the gas pressure, to a reduction in gas pressure that can result in oscillations about the mode boundary. The resulting neutron output variations are detrimental to the overall quality of the measurements.

Fifth, the means for generating the magnetic field, intended to lengthen the electrons path, are relatively cumbersome and increase the overall dimensions and weight of the neutron generator. This is of concern in a logging tool where room is limited.

An alternative to the cold cathode ion sources are "hot cathode" ion sources, proposed as early as 1939, associated to a spectrograph, as depicted e.g. in the article "Focused Beam Source of Hydrogen and Helium Ions" by G. W. Scott Jr., in *Physical Review*, May 15, 1939, volume 55. Further developments in the same technical area provided some modifications to the basic hot cathode ion source; see e.g. the article "An Electrostatically Focused Ion Source and its Use in a Sealed-Off D.C. Neutron Source" by J. D. L. H. Wood and A. G. Crocker, *Nuclear Instruments and Methods*, 21 (1963) pages 47-48; or the article "Electron Bombardment Ion Source for Low Energy Beams" by S. Dworetzky et al., in *The Review of Scientific Instruments*, November 1968, volume 39, No. 11. A "hot cathode" typically comprises a material susceptible, when heated, to emit electrons. The cathode is disposed above, or concentrically to, the anode. An extracting electrode (also called focusing electrode) is placed at the front of the anode to extract ions, generated from collisions between electrons and gas molecules, and focus such ions so as to form an ion beam.

Hot cathode ion sources by themselves bring some improvements with respect to cold cathode ion sources. Hot cathode sources for instance: (i) do not always require a magnetic field, and this allows a substantial reduction in weight and dimensions; (ii) are able to generate an optimum electron flux in a relatively short period of time after the voltage pulse is applied to the anode; (iii) as being used in sealed neutron generator, do not show troublesome mode transitions in the range of gas pressure where these devices normally operate; and (iv) do not require a high anode or cathode voltage

4

when used in neutron generators including a discharging gas made of deuterium and tritium; this reduced voltage entails a reduction in electrode erosion.

However, hot cathode ion sources present drawbacks of their own compared to cold cathode ion sources, such as: (i) additional power; (ii) a relatively reduced lifetime at least for most of hot cathode filament materials, and (iii) the need for a specific structure to support the hot cathode and anode, especially in view of the severe shock and vibration conditions encountered during logging operations.

Moreover, according to applicant's knowledge, the known hot cathode ion sources were implemented in laboratories and designed mainly for experimental purpose, which applications are not subjected to the severe environmental constraints typical of the logging techniques. In other words, performances of these known hot cathode ion source could be considered sufficient for laboratory measurements but would not be acceptable for logging applications, even assuming they could be directly implemented in a logging tool. Among others, one could mention, as constraints specific to logging applications: weight and dimensions, safety, neutron pulse shape, neutron output, power requirements, and operating lifetime.

Accordingly, although the neutron generators used so far in the logging techniques have been working relatively satisfactory, there still is a need for an improvement to the neutron output and especially to the neutron pulse shape.

#### SUMMARY OF THE INVENTION

It is a general object of the present invention to provide an improved neutron generator, especially suitable for logging techniques.

It is a first particular object of the invention to propose a neutron generator providing neutron pulses having a substantially square shape, to wit: (i) a sharp rise; (ii) a substantially "flat" plateau; and (iii) a sharp cut-off (very abrupt termination of the neutron burst).

A second specific object of the invention is to propose a neutron generator of reduced weight and dimensions.

It is a third particular object of the invention to provide a neutron generator with relatively low ion energies at the low source aperture, thus reducing metal erosion of the electrodes and improving the voltage stability.

It is a fourth specific object of the invention to propose a neutron generator wherein the rise edge (or leading edge) of the neutron flux appears with a reduced delay after the voltage pulse is applied to the anode, thus simplifying the timing control process of the pulses.

It is a fifth specific object of the invention to provide a neutron generator with a hot cathode ion source requiring minimum power to operate.

It is a sixth object of the invention to provide a neutron generator requiring pulses of relatively low voltages to produce the ion beam, making it possible to eliminate the need for an ion source transformer. (by using, e.g. solid state switches).

It is a seventh object of the invention to provide a neutron generator wherein pulses of very different duration can be applied to the ion source, allowing for complex series of pulse lengths during a well logging measurement without requiring a reconfiguration of the ion source pulsing circuit.



5

It is an eighth specific object of the invention to provide a neutron generator showing a high mechanical or electrical ruggedness, especially for use in a logging tool.

These objects and other are attained, according to the invention, with a logging tool for investigating earth formations surrounding a borehole, comprising:

- 1) a sonde incorporating at least one radiation detector; and
- 2) a neutron generator comprising:
  - (i) an ion source comprising an anode and a thermionic cathode disposed in an ionizable gas environment;
  - (ii) means for heating the cathode so that the latter emits electrons which, when colliding with the gas atoms, generate ions;
  - (iii) a target;
  - (iv) an electrical gap to accelerate ions from the ion source towards the target upon impingement of the ions; and
  - (v) control means for applying voltages to the anode, cathode and electrical gap.

The cathode is preferably of the dispenser or volume type. The terms "thermionic", "dispenser" and "volume" will be hereafter explained.

In a preferred embodiment, the gas comprises at least one hydrogen isotope and the gas environment constitutes a sealed chamber.

The cathode advantageously includes a substratum made of porous tungsten and an emitter material including barium oxide and/or strontium oxide.

The voltage supply means for the cathode are distinct from the cathode heating means.

The neutron generator may further comprise means for preventing slow ions still present in the ion source at the end of the voltage pulse, from leaving the ion source. The preventing means comprises a cut-off electrode disposed at the end of the ion source and which is submitted to voltage pulses synchronized with and complementary to pulses applied to the anode, and to a positive voltage between the pulses. The cut-off electrode includes a convex mesh screen.

The invention also relates to a neutron generator comprising:

- an ion source comprising an anode and a dispenser or volume type cathode disposed in an ionizable gas environment including at least one hydrogen isotope;
- means for heating the cathode so that the latter emits electrons which, when colliding with the gas atoms, generate ions;
- a target;
- an electrical gap to accelerate ions from the ion source towards the target upon impingement of the ions; and
- control means for applying voltages to the anode, cathode and electrical gap.

The characteristics and advantages of the invention will appear better from the description to follow, given by way of a non limiting example, with reference to the appended drawing in which:

#### BRIEF DESCRIPTION OF THE DRAWINGS

FIG. 1 is a cross section view of a neutron generator according to the invention;

FIGS. 2A and 2B are schematic representations of respective alternate embodiments of the cathode; and

5,293,410

6

FIG. 3 is an example of plot of neutron output versus time, showing the corresponding neutron pulse.

#### DESCRIPTION OF THE PREFERRED EMBODIMENT

FIG. 1 shows a neutron generator 10 which may be used in a logging tool such as described e.g. in U.S. Pat. Nos. 4,794,792, 4,721,853 or 4,600,838, which are herein incorporated by reference. The major components of the neutron generator 10 are a hollow cylindrical tube 11 made of an insulating material such as alumina ceramic and having its respective longitudinal extremities fixed to a ceramic ring 12 and a conductive ring 13, an ion source 45, a gas supply means 25, an extracting electrode 50, and a massive copper target electrode 15. A transverse header 14 and the target electrode 15 close the rings 12 and 13, respectively, to provide a gas-tight cylindrical envelope. Ring 12 comprises parallel transversely disposed flanges 6, 7, 8, and 9, providing electrically conductive paths and sturdy support for the generator components as described subsequently in more complete detail. Flanges 6-9 are substantially equally spaced along ring 12, between header 14 and the corresponding extremity of tube 11. The gas supply means 25 is disposed transversely to the longitudinal axis I-I of the generator 10, between first flange 6 and second flange 7, closest to header 14. The gas supply means 25 comprises a helically wound filament 26 of tungsten, which may be heated to a predetermined temperature by an electric current from a gas supply power means 105 to which both ends 26a and 26b of filament 26 are connected.

A film 44 of zirconium or the like, for absorbing and emitting deuterium and tritium, is coated on the intermediate turns of the filament 26 in order to provide a supply of these gases and to control gas pressure during generator operation. Due to physical isolation, a substantially uniform temperature can be maintained along the coated intermediate turns of the filament helix 26.

As the gases released from the film 44 are withdrawn from the atmosphere within the envelope for ion generation, more gases are emitted to restore the envelope gas pressure to a level commensurate with the temperature of the intermediate portion of the filament helix 26. The gases emitted by the film 44 diffuse through holes provided in flanges 7-9, i.e. a hole 31 in second flange 7, a hole 33 in third flange 8 and holes 34, 35 in fourth flange 9. The gases emitted finally enter an ion source 45 interposed between the gas supply means 25 and the extremity of tube 11 facing ring 12. An annular shaped electrical insulator 90 is interposed between tube 11 and ring 12. More details on the structure of the neutron generator can be found e.g. in U.S. Pat. Nos. 3,756,682; or 3,775,216; or 3,546,512, which are herein incorporated by reference.

The ion source 45 comprises a cylindrical hollow anode 57 aligned with the longitudinal axis I-I of the generator 10 and made out of either a mesh or a coil. Typically, a positive ionizing potential (either direct or pulsed current) comprised in the range of 100-300 volts relative to the cathode, is applied to the anode 57. In one exemplary embodiment of the invention, the anode 57 is about 0.75 inch (1.9 cm) long and has a diameter of approximately 0.45 inch (1.14 cm). The anode 57 is secured rigidly to flange 9, e.g. by conductive pads 60.

The ion source 45 also includes a cathode 80 disposed close to the outside wall of the anode 57, in a substantially median position with respect to the anode. The

5,293,410

7

cathode 80 comprises an electron emitter 81 consisting of a block of material susceptible, when heated, to emit electrons. Emitter 81 is fixed (e.g. by brazing) to the U-shaped end 82 of an arm 84 being itself secured to flange 8. The arm 84 provides also an electrical connection between the emitter 81 and a hot cathode heater current means 100 able to generate e.g. a few watts for heating the emitter. Heater current 100 is known per se (see U.S. Pat. Nos. 3,756,682, 3,775,216 or 3,546,512) and thus does not need to be further described. According to an alternate embodiment shown on FIG. 2A, the cathode 80 could also comprise two arms (similar to arm 84), each provided at one of its ends with a block of dispenser material, both arms being disposed outside the hollow anode 57. This embodiment (cathode disposed outside the anode) prevents the material evaporated from the cathode from coating the surface of suppressor 75 causing enhanced field emission.

In a further alternate embodiment shown on FIG. 2B, the cathode 80 may also comprise a single arm provided at one end with an emitter, the arm being disposed inside the hollow anode 57, substantially in the center thereof. According to this embodiment, the cathode emitting surfaces are so arranged that electron emission is perpendicular to the axis of the ion source. This embodiment reduces the amount of cathode material being deposited on the suppressor surface.

Now described in more detail is the structure of the cathode 80. The thermionic cathode 80 comprises an emitter block including a material forming a substratum and a material susceptible to emit electrons. Thermionic cathodes here mean heated cathodes, as opposed to cold cathodes which emit electrons when not heated. The thermionic cathodes can be broken down into: (i) those with inherent electron emission capability if they can be heated high enough in temperature without melting (e.g. pure tungsten or tantalum or lanthanum hexa boride), and (ii) those to which use a low work function material is applied, either to the surface of a heated substratum (such as thoria coated tungsten, oxide coated) [called "oxide cathode"], or impregnated by bulk into a porous substrate [called "dispenser" cathode]. General information on thermionic cathodes can be found in the book "Materials and Techniques for Electron Tubes" by W. Kohl, Reinhold Publishing, 1960, pages 519-566, which is herein incorporated by reference. In other words, "oxide" cathode involve what could be called a "surface" reaction, whereas in a "dispenser" cathode there occurs what could be called a "volume" reaction. General information on "dispenser" or "volume" type cathodes can be found e.g. in the article "Surface Studies of Barium and Barium Oxide on Tungsten and its Application to Understanding the Mechanism of Operation of an Impregnated Tungsten Cathode" by R. Forman, in Journal of Applied Physics, vol. 47, No 12, December 1976, pages 5272-5279; or in the article "A Cavity Reservoir Dispenser Cathode for CRT's and Low-cost Traveling-wave Tube Applications" by L. R. Falce, in IEEE transactions on electron devices, vol 36, No 1, January 1989. Cathodes of the "oxide" or "surface" type are described in the article "Compact Pulsed Generator of Fast Neutrons" by P. O. Hawkins and R. W. Sutton, The Review of Scientific Instruments, March 1960, Vol. 31, Number 3, Pages 241-248; in "Focused Beam Source of Hydrogen and Helium Ions" by G. W. Scott, Jr., in Physical Review, May 15, 1939, vol 55, pages 954-959; in U.S. Pat. No. 3,490,944 or U.S. Pat. No.

8

3,276,974; or in the article "Operation of Coated Tungsten Based Dispenser Cathodes in Nonideal Vacuum" by C. R. K. Marrian and A. Shih, in IEEE Transactions on Electron Devices, vol. 36, No 1, January 1989. All of the above mentioned documents are incorporated herein by reference.

The thermionic cathode 80 of the ion source of the present invention is preferably of the "dispenser" or "volume" type. A dispenser cathode used in a hydrogen environment maximizes electron emissions per heater power unit compared to other thermionic type cathodes (such as LaB<sub>6</sub> or W), while operating at a moderate temperature. The emitter block 81 comprises a substrate made of porous tungsten, impregnated with a material susceptible to emit electrons, such as compounds made with combinations of e.g. barium oxide and strontium oxide. Each cathode has different susceptibility to their operating environment (gas pressure and gas species). Dispenser cathodes are known to be the most demanding in terms of the vacuum requirements and care that is needed to avoid contamination. One, among others, of the (novel and non-obvious) features of the invention includes using, in a neutron generator, a dispenser cathode which works as long as several hundred hours in a hydrogen gas environment of pressure on the order of several mTorr, providing an average electron emission current of from 50 to 80 mA yet requiring only a few watts of heater power.

The cathode 80 according to the invention is provided with hot cathode heater current 100 which is distinct from the ion source voltage supply 102. Such implementation permits a better control of both heater current means 100 and voltage supply 102.

The extracting electrode 50 is disposed at the end of the ion source 45 facing target electrode 15, at the level of the junction between tube 11 and ring 12. The extracting electrode 50 is supported in fixed relation to the ring 12 by a fifth flange 32. The extracting electrode 50 comprises a massive annular body 46, e.g. made of nickel or an alloyed metal such as KOVAR (trademark), and which is in alignment with the longitudinal axis I-I of the tube 11. A central aperture 47 in the body 46 diverges outwardly in a direction away from the ion source 45 to produce at the end of body 46 facing target electrode 15 a torus-shaped contour 51. The smooth shape contour 51 reduces a tendency to voltage breakdown that is caused by high electrical field gradients.

Moreover, the extracting electrode 50 provides one of the electrodes for an accelerating gap 72 that impels ionized deuterium and tritium particles from the source 45 toward a deuterium- and tritium-filled target 73. The target 73 comprises a thin film of titanium or scandium deposited on the surface of the transverse side, facing ion source 45, of the target electrode 15.

The potential that accelerates the ions to the target 73 is established, to a large extent, between the extracting electrode 50 and a suppressor electrode 75 hereafter described. The suppressor electrode 75 is a concave member that is oriented toward the target electrode 15 and has a centrally disposed aperture 78 which enables the accelerated ions to from the gap 72 to the target 73. The aperture 78 is disposed between the target 73 and the extracting electrode 50. The suppressor electrode 75 is connected to a high voltage supply means 103 which is also connected, through a resistor "R" to the ground. In order to prevent electrons from being extracted from the target 73 upon ion bombardment (these extracted



5,293,410

9

electrons being called "secondary electrons"), the suppressor electrode 75 is at a negative voltage with respect to the voltage of the target electrode 15.

The velocity of the ions leaving the ion source 45 is, on an average, relatively lower than ion velocity in a known Penning source. Consequently, these slow moving ions tend to generate a tail in the neutron pulse, at the moment the voltage pulse is turned off. The presence of an end tail is detrimental to the pulse shape which, as already stated, is of importance. The present invention remedies this situation by adding to the extractor a cut-off electrode, in the form of a mesh screen 95, which is fixed, e.g. by welding, to the aperture 47 of the extracting electrode 50, facing the ion source 45. The mesh screen 95 (cut-off electrode) is e.g. made of high transparency molybdenum. The cut-off electrode 95 is submitted to voltage pulses synchronized with and complementary to the voltage pulses applied to the anode 57. The pulses applied to cut-off electrode 95 are positive and e.g. of 100 to 300 volts. In an alternate embodiment, the cut-off electrode 95, instead of being submitted to voltage pulses, is maintained at a positive voltage, of e.g. a few volts. This low positive voltage prevents the slow ions produced at the end of the pulse in the ion beam from leaving the ion source, and thus allows one to truncate the terminal part of the ion beam, which in turn provides a sharp cut-off at the end of the neutron pulse (i.e. a short fall time). The cut-off electrode 95 is preferably made of a metallic grid in the form of a truncated sphere, and its concavity turned towards the target 73. Part of the mesh screen 95 might protrude inside cylindrical hollow cathode 57. FIG. 3 shows two examples of neutron pulses obtained respectively with cut-off electrode (solid line) and without cut-off voltage (dotted line), everything else being equal. The benefit to the neutron pulse shape (especially the fall time) derived from the cut-off electrode is easily appreciated from FIG. 3.

In an alternate embodiment, (wherein the extractor 50 is not provided with the cut-off screen 95), the end tail of the ion beam is truncated by applying a positive voltage pulse to the extracting electrode 50.

In order to generate a controlled output of neutrons, continuously or in recurrent bursts, an ion source voltage supply means 102 provides power for the bombarding ion beam. For pulse operation, an ion source pulser 101 is provided at the output of ion source voltage supply 102 to regulate the operation of voltage supply to the ion source. The ion source pulser 101 has a direct output connected to the anode 57 (via flange 9) and a complementary output connected to extracting electrode 50. The high voltage supply 103, the ion source voltage supply 102, and the ion source pulser 101 may be of any suitable type such as e.g. described in U.S. Pat. Nos. 3,756,682 or 3,546,512, already referred to. A gas supply means regulator 104 (connected to the high voltage supply means 103) regulates, through a gas supply power means 105, the intensity of the ion beam by controlling the gas pressure in the envelope. The current flowing through resistor r provides a measure of ion beam current which enables the gas supply regulator 104 to adjust the generator gas pressure accordingly. The voltage developed by the high voltage supply 103, moreover, is applied directly to the suppressor electrode 75 and through a resistor R to the target electrode 15. The voltages thus developed provide the accelerating and suppressor voltages, respectively. During operation, current is passed through the filament 26

10

of the gas supply 25 in an amount regulated by the gas supply regulator means 104 to achieve a deuterium-tritium pressure within the generator envelope that is adequate to obtain a desired ion beam current and ad hoc conditions for the generator to operate.

The high voltage established between the extracting electrode 50 and the suppressor electrode 75 produces a steep voltage gradient that accelerates deuterium and tritium ions from the electrode aperture 47 in extracting electrode 50 toward the target 73. The energy imparted to the ions is sufficient to initiate neutron generating reactions between the bombarding ions and the target nuclei and to replenish the target 73 with fresh target material. Initial bombardment of a fresh target 73 by, for example, a half-and-half mixture of deuterium and tritium ions, produces relatively few neutrons. As increasing quantities of impinging ions penetrate and are held in the lattice of the target, however, the probability for nuclear reactions increases. Thus, after a short period of ion bombardment, a continuous or pulsed output ranging from  $10^7$  to  $10^9$  neutrons per second is reached.

As previously described, the regulator 104 regulates the power supplied to the filament 26 and thereby manipulates the tube gas pressure and the ion beam intensity to produce the desired neutron output. If the neutron output should increase as a result of an increase in the current, a corresponding increase in current through the resistor causes the regulator 104 to decrease the filament power supply and thereby reduce the gas pressure within the generator. The lower gas pressure in effect decreases the number of ions available for acceleration, and thus restores the neutron output to a stable, predetermined value. Similarly, a decrease in the current through the resistance causes the regulator 104 to increase the generator gas pressure.

If desired, the neutron output can be monitored directly, and either the ion source voltage supply or the high voltage power supply can be controlled automatically or manually to achieve stable generator operation. In the event the generator is supplied only with deuterium gas, neutrons are produced as a result of deuterium-deuterium interactions, rather than the deuterium-tritium reactions considered in the foregoing illustrative description.

The present invention provides the following advantages, as compared to the prior art neutron generators.

Since no magnet is necessary, the neutron generator is lighter and of smaller dimensions than the prior art generators. This is a substantial improvement for logging applications due to the limited space available in the logging tools.

The use of a dispenser cathode virtually cancels, or at least substantially reduces, the delay between the time the generator is turned on and the production of neutrons, and thus provides a sharp rise of neutron burst. This also results in an improved burst timing control.

Also, the thermionic cathode operates without troublesome plasma mode transitions responsible for disturbing jumps in the neutron output, and for difficulties in using the beam control feedback loop with the reservoir heater.

The erosion of the extractor and consequent coating of insulator surfaces, by sputtered metal due to ion bombardment, is substantially reduced because of the relatively low anode voltage. The reduced anode voltage allows one to use simplified pulsing circuitry.

The voltage applied to the cut-off screen-electrode 95 allows the tail of the ion beam to be cut-off, made

5,293,410

11

mainly of slow ions, and thus allows the generation of a neutron pulse showing a sharp end edge.

Finally, the lifetime of the cathode is in the range of several hundred hours in a hydrogen gas environment of pressure on the order of several mTorr providing an average electron emission current of from 50 to 80 mA, yet requiring only a few watts of heater power.

Above all, the invention is beneficial in term of pulse shape. In particular, the neutron pulse shows the following characteristics, as can be seen from FIG. 3:

the time required for the instantaneous neutron output to reach its maximum, called plateau, measured from the instant when the voltage is applied to said cathode, is less than 1.5 microsecond;

the fall time, i.e. the period of time between the instant when the voltage applied to said cathode is turned off and the instant when the instantaneous neutron output falls to 10% of the plateau, is less than 0.5 microsecond;

the neutron output reaches a plateau which remains constant within a 10% range thereof, over a pulse time width comprised between 5 and 500 microseconds;

the time lag between the instant when the voltage is applied to said cathode and the instant when the instantaneous neutron output reaches 10% of the plateau, is less than 0.5 microsecond; another benefit is that the time lag is independent of operational parameters of the ion source, such as gas pressure; and

the rise time for the neutron output to reach 90% of the plateau, measured from the time when the neutron output is 10% of said plateau, is less than 1 microsecond.

What is claimed is:

1. A neutron generator comprising:

- (i) an ion source comprising an anode and a dispenser cathode disposed in an ionizable gas environment;
- (ii) means for heating said cathode so that the latter emits electrons which, when colliding with said gas atoms, generate ions;
- (iii) a target;
- (iv) an electrical gap to accelerate ions from said ion source towards said target upon impingement of said ions; and
- (v) control means for applying voltages to said anode, cathode and electrical gap, wherein a voltage applied to said anode by said control means is between 100 and 300 Volts to substantially reduce metal sputtering within the neutron generator.

2. The neutron generator according to claim 1, wherein said gas comprises at least one hydrogen isotope.

3. The neutron generator according to claim 2, wherein said gas environment constitutes a sealed chamber.

4. The neutron generator according to claim 1, wherein said cathode comprises at least one block of material comprised of a substrate impregnated with an electron emitting material.

5. The neutron generator according to claim 4 wherein said substrate is tungsten and said emitter material includes barium oxide.

6. The neutron generator according to claim 1, wherein said voltages are in the form of square voltage pulses.

12

7. The neutron generator according to claim 1 wherein said voltage applying means for said cathode is distinct from said cathode heating means.

8. The neutron generator according to claim 1, wherein said anode is made of a hollow elongated body permeable to electrons.

9. The neutron generator according to claim 8, wherein said anode is made of a cylindrical metallic coil.

10. The neutron generator according to claim 8, wherein said anode is made of a cylinder-shaped mesh.

11. The neutron generator according to claim 4, wherein said block is disposed at one end of an arm connected to said heating means and to said control means.

12. The neutron generator according to claim 8, wherein said cathode is disposed inside said anode.

13. The neutron generator according to claim 8, wherein said cathode is disposed outside said anode.

14. The neutron generator according to claim 11 wherein said cathode comprises two arms disposed diametrically on the outside of said anode.

15. The neutron generator according to claim 1, further comprising an extracting electrode disposed at the end of said ion source facing said target and submitted to a voltage complementary to the anode voltage.

16. The neutron generator according to claim 15, wherein the end of said extracting electrode facing said target is torus shaped.

17. The neutron generator according to claim 6, further comprising means for preventing slows ions, still present in said ion source at the end of said voltage pulse, from leaving said ion source.

18. The neutron generator according to claim 17 wherein said preventing means comprises a cut-off electrode disposed at the end of the ion source and which is submitted to voltage pulses synchronized with and complementary to pulses applied to said anode, and to a positive voltage between said pulses.

19. The neutron generator according to claim 18 wherein said cut-off electrode includes a mesh screen.

20. The neutron generator according to claim 19 wherein said mesh screen is in the form of a truncated sphere having its concavity facing said target.

21. The neutron generator according to claim 17 wherein said preventing means comprises means for applying to said extracting electrode negative voltage pulses synchronized with pulses applied to said anode, and a positive voltage between said pulses.

22. The neutron generator according to claim 3 comprising a cylindrical insulator disposed between said ion source and said target.

23. The neutron generator according to claim 22 wherein said insulator is made of ceramic.

24. The neutron generator according to claim 1 wherein said gas environment comprises a gas supply means incorporating a helical filament coated with material able, when heated, to emit atoms of at least one hydrogen isotope and disposed transversely to the longitudinal axis of the accelerating gap.

25. The neutron generator according to claim 23 wherein the gas pressure in said gas environment is comprised between 0.5 milliTorr and 20 milliTorr.

26. A neutron generator comprising: an ion source comprising an anode and a dispenser or volume type cathode disposed in an ionizable gas environment including at least one hydrogen isotope;



5,293,410

13

means for heating said cathode so that the latter emits electrons which, when colliding with said gas atoms, generate ions;

a target;

an electrical gap to accelerate ions from said ion source towards said target upon impingement of said ions; and

control means for applying voltages to said anode, cathode and electrical gap, wherein a voltage applied to said anode by said control means is between 100 and 300 Volts to substantially reduce metal sputtering within the neutron generator.

27. A logging tool for investigating earth formations surrounding a borehole, comprising a sonde incorporating at least one radiation detector and a neutron generator, said neutron generator comprising:

(i) an ion source comprising an anode and a dispenser cathode disposed in an ionizable gas environment;

(ii) means for heating said cathode so that the latter emits electrons which, when colliding with said gas atoms, generate ions;

(iii) a target;

(iv) an electrical gap to accelerate ions from said ion source towards said target upon impingement of said ions; and

(v) control means for applying voltages to said anode, cathode and electrical gap, wherein a voltage applied to said anode by said control means is between 100 and 300 Volts to substantially reduce metal sputtering within the neutron generator.

28. A neutron generator for logging applications, comprising:

a source of ionizable gas;

an ion source for ionizing said gas and including an anode and a dispenser type cathode designed to emit electrons able to impinge on gas atoms so as to generate ions;

a target spaced apart from said ion source by an accelerating gap, and being able to emit neutrons upon impingement of ions issued from said ion source;

control means for applying voltages to said anode, cathode and electrical gap; and

means for operating said control means such that the rise time for the neutron output to reach 90% of the maximum output plateau, measured from the time when the neutron output is 10% of said plateau, is less than 1 microsecond.

29. A neutron generator for logging applications, comprising:

a source of ionizable gas;

an ion source for ionizing said gas and including an anode and a dispenser type cathode designed to emit electrons able to impinge on gas atoms so as to generate ions;

a target spaced apart from said ion source by an accelerating gap, and being able to emit neutrons upon impingement of ions issued from said ion source;

control means for applying voltages to said anode, cathode and electrical gap; and

means for operating said control means such that the time lag between the instant when the voltage is applied to said cathode and the instant time when the instantaneous neutron output reaches 10% of the maximum output (plateau), is less than 0.5 microsecond.

30. A neutron generator for spectral logging applications, comprising:

a source of ionizable gas;

14

an ion source for ionizing said gas and including an anode and a dispenser type cathode designed to emit electrons able to impinge on gas atoms so as to generate ions;

a target spaced apart from said ion source by an accelerating gap, and being able to emit neutrons upon impingement of ions issued from said ion source;

control means for applying pulsing voltages to said anode, cathode and electrical gap; and

means for operating said control means such that the neutron output reaches a maximum value (or plateau) which remains constant within a 10% range thereof, over a pulse time width comprised between 18 and 25 microsecond.

31. A neutron generator for logging applications, comprising:

a source of ionizable gas;

an ion source for ionizing said gas and including an anode and a dispenser type cathode designed to emit electrons able to impinge on gas atoms so as to generate ions;

a target spaced apart from said ion source by an accelerating gap, and being able to emit neutrons upon impingement of ions issued from said ion source;

control means for applying voltages to said anode, cathode and electrical gap; and

means for operating said control means such that the fall time between the instant when the voltage applied to said cathode is turned off and the instant time when the instantaneous neutron output falls to 10% of the maximum output (plateau), is less than 0.5 microsecond.

32. A neutron generator for spectral logging applications, comprising:

a source of ionizable gas;

an ion source for ionizing said gas and including an anode and a dispenser type cathode designed to emit electrons able to impinge on gas atoms so as to generate ions;

a target spaced apart from said ion source by an accelerating gap, and being able to emit neutrons upon impingement of ions issued from said ion source;

control means for applying voltages to said anode, cathode and electrical gap; and

means for operating said control means such that the time required for the instantaneous neutron output to reach its maximum (plateau) value, measured from the instant time when the voltage is applied to said cathode, is less than 1.5 microsecond.

33. A method for investigating earth formation surrounding a borehole, comprising the steps of:

irradiating, at a first given location in the borehole, the borehole materials and the earth formation with bursts of neutrons from a neutron generator including an ion source comprising an anode and a dispenser cathode disposed in an ionizable gas environment, by applying voltage pulses to the cathode and heating the dispenser cathode;

detecting, at a second given location in the borehole, radiation resulting from interaction of the neutrons with the formation;

generating signals representative of the radiation;

controlling the neutron output during the start of the neutron burst such that the rise time for the neutron output to reach 90% of its plateau, measured from the time when the neutron output is 10% of the plateau, is less than 1 microsecond; and

5,293,410

15

determining from the signals a characteristic of the earth formation surrounding the borehole.

34. A method for investigating earth formation surrounding a borehole, comprising the steps of:

- generating bursts of neutrons from a neutron generator including an ion source comprising an anode and a dispenser cathode disposed in an ionizable gas environment, by applying voltage pulses to the cathode and heating the cathode;
- irradiating, at a first given location in the borehole, the borehole materials and the earth formation with bursts of neutrons;
- detecting, at a second given location in the borehole, radiation resulting from interaction of the neutrons with the formation;
- generating signals representative of the radiation;
- controlling the neutron burst during the start of the neutron burst such that the time lag between the instant when the voltage is applied to the cathode and the instant time when the instantaneous neutron output reaches 10% of its plateau, is less than 0.5 microsecond; and
- determining from the signals a characteristic of the earth formation surrounding the borehole.

35. A method for investigating earth formation surrounding a borehole, comprising the steps of:

- irradiating, at a first given location in the borehole, the borehole materials and the earth formation with bursts of neutrons from a neutron generator including an ion source comprising an anode and a dispenser cathode disposed in an ionizable gas environment, by applying voltage pulses to the cathode and heating the dispenser cathode;
- detecting, at a second given location in the borehole, radiation resulting from interaction of the neutrons with the formation;
- generating signals representative of the radiation;
- controlling the neutron output such that the neutron output reaches a plateau which remains constant within a 10% range thereof, over a burst time width comprised between 18 and 25 microsecond; and
- determining from the signals a characteristic of the earth formation surrounding the borehole.

36. A method for investigating earth formation surrounding a borehole, comprising the steps of:

- generating bursts of neutrons from a neutron generator including an ion source comprising an anode and a dispenser cathode disposed in an ionizable gas environment, by applying voltage pulses to the cathode and heating the cathode;
- irradiating, at a first given location in the borehole, the borehole materials and the earth formation with bursts of neutrons;
- detecting, at a second given location in the borehole, radiation resulting from interaction of the neutrons with the formation;
- generating signals representative of the radiation;
- controlling the neutron output such that the fall time between the instant when the voltage applied to the cathode is turned off and the instant time when the instantaneous neutron output falls to 10% of its plateau, is less than 0.5 microsecond; and
- determining from the signals a characteristic of the earth formation surrounding the borehole.

37. A method for investigating earth formation surrounding a borehole, comprising the steps of:

- generating bursts of neutrons from a neutron generator including an ion source comprising an anode and a dispenser cathode disposed in an ionizable

16

- gas environment, by applying voltage pulses to the cathode and heating cathode;
- irradiating, at a first given location in the borehole, the borehole materials and the earth formation with bursts of neutrons;
- detecting, at a second given location in the borehole, radiation resulting from interaction of the neutrons with the formation;
- generating signals representative of the radiation;
- controlling the neutron output during the neutron burst such that the time required for the instantaneous neutron output to reach a plateau, measured from the instant time when the voltage is applied to the cathode, is less than 1.5 microsecond; and
- determining from the signals a characteristic of the earth formation surrounding the borehole.

38. A method for investigating earth formation surrounding a borehole, comprising the steps of:

- generating bursts of neutrons from a neutron generator including an ion source comprising an anode and a dispenser cathode disposed in an ionizable gas environment, by applying voltage pulses to the cathode and heating the cathode;
- irradiating, at a first given location in the borehole, the borehole materials and the earth formation with bursts of neutrons;
- detecting, at a second given location in the borehole, radiation resulting from interaction of the neutrons with the formation;
- generating signals representative of the radiation;
- controlling the neutron output such that: (i) the rise time for the neutron output to reach 90% of its plateau, measured from the time when the neutron output is 10% of the plateau, is less than 1 microsecond; (ii) the fall time between the instant when the voltage applied to the cathode is turned off and the instant time when the instantaneous neutron output falls to 10% of the plateau, is less than 0.5 microsecond; and
- determining from the signals a characteristic of the earth formation surrounding the borehole.

39. A method for investigating earth formation surrounding a borehole, comprising the steps of:

- generating bursts of neutrons from a neutron generator including an ion source comprising an anode and a dispenser cathode disposed in an ionizable gas environment, by applying voltage pulses to the cathode and heating the cathode;
- irradiating, at a first given location in the borehole, the borehole materials and the earth formation with bursts of neutrons;
- detecting, at a second given location in the borehole, radiation resulting from interaction of the neutrons with the formation;
- generating signals representative of the radiation;
- controlling the neutron output such that: (i) the rise time for the neutron output to reach 90% of its plateau, measured from the time when the neutron output is 10% of the plateau, is less than 1 microsecond; (ii) the fall time between the instant when the voltage applied to the cathode is turned off and the instant time when the instantaneous neutron output falls to 10% of its plateau, is less than 0.5 microsecond; and (iii) the neutron output reaches a plateau which remains constant within a 10% range thereof, over a pulse time width comprised between 18 and 25 microsecond; and
- determining from the signals a characteristic of the earth formation surrounding the borehole.

\* \* \* \* \*



## Appendix F: Supertex LR8 Datasheet

**Supertex inc.**

**LR8**

### High Input Voltage, Adjustable 3-Terminal Linear Regulator

#### Features

- ▶ 13.2 - 450V input voltage range
- ▶ Adjustable 1.20 - 440V output regulation
- ▶ 5% output voltage tolerance
- ▶ Output current limiting
- ▶ 10 $\mu$ A typical ADJ current
- ▶ Internal junction temperature limiting

#### Applications

- ▶ Off-line SMPS startup circuits
- ▶ Adjustable high voltage constant current source
- ▶ Industrial controls
- ▶ Motor controls
- ▶ Battery chargers
- ▶ Power supplies

#### General Description

The Supertex LR8 is a high voltage, low output current, adjustable linear regulator. It has a wide operating input voltage range of 13.2 - 450V. The output voltage can be adjusted from 1.20 - 440V provided that the input voltage is at least 12V greater than the output voltage. The output voltage can be adjusted by means of two external resistors R1 and R2 as shown in the typical application circuits. The LR8 regulates the voltage difference between V<sub>OUT</sub> and ADJ pins to a nominal value of 1.20V. The 1.20V is amplified by the external resistor ratio R1 and R2. An internal constant bias current of typically 10 $\mu$ A is connected to the ADJ pin. This increases V<sub>OUT</sub> by a constant voltage of 10 $\mu$ A times R2.

The LR8 has current limiting and temperature limiting. The output current limit is typically 20mA and the minimum temperature limit is 125°C. An output short circuit current will therefore be limited to 20mA. When the junction temperature reaches its temperature limit, the output current and/or output voltage will decrease to keep the junction temperature from exceeding its temperature limit. For SMPS start-up circuit applications, the LR8 turns off when an external voltage greater than the output voltage of the LR8 is applied to V<sub>OUT</sub> of the LR8. To maintain stability, a bypass capacitor of 1.0 $\mu$ F or larger and a minimum DC output current of 500 $\mu$ A are required.

The device is available in TO-243AA (SOT-89), TO-252 (D-PAK), and TO-92 packages.

#### Typical Application Circuit

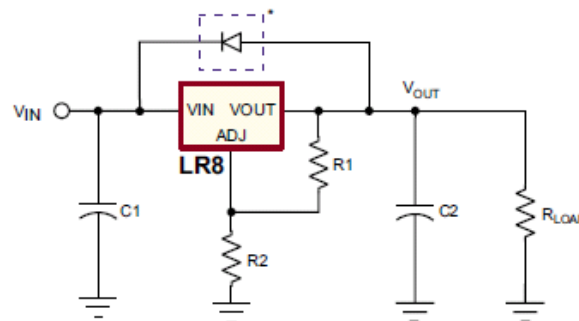

\*Required for conditions where V<sub>IN</sub> is less than V<sub>OUT</sub>.



LR8

Ordering Information

Device	Package Options		
	TO-252 (D-PAK)	TO-92	TO-243AA (SOT-89)
LR8	LR8K4-G	LR8N3-G	LR8N8-G

-G indicates package is RoHS compliant ("Green")



Pin Configurations



TO-252 (K4)



TO-92 (N3)

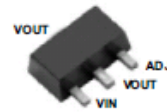

TO-243AA (SOT-89) (N8)

Absolute Maximum Ratings

Parameter	Value
V <sub>IN</sub> input voltage (voltages ref to ADJ)	-0.5V to +480V
Output voltage range	-0.5V to +470V
Operating ambient temperature range	-40°C to +85°C
Operating junction temperature range	-40°C to +125°C
Storage temperature range	-65°C to +150°C

Stresses beyond those listed under "Absolute Maximum Ratings" may cause permanent damage to the device. These are stress ratings only, and functional operation of the device at these or any other conditions beyond those indicated in the operational sections of the specifications is not implied. Exposure to absolute maximum rating conditions for extended periods may affect device reliability.

Product Marking

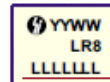

YY = Year Sealed  
 WW = Week Sealed  
 L = Lot Number  
 \_\_\_\_\_ = "Green" Packaging

TO-252 (K4)



Y = Last Digit of Year Sealed  
 W = Code for Week Sealed  
 L = Lot Number  
 \_\_\_\_\_ = "Green" Packaging

TO-92 (N3)

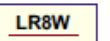

W = Code for Week Sealed  
 \_\_\_\_\_ = "Green" Packaging

TO-243AA (SOT-89) (N8)

Electrical Characteristics

(Test conditions unless otherwise specified: -40°C < T<sub>A</sub> < 85°C.)

Sym	Parameter	Min	Typ	Max	Units	Conditions
V <sub>IN</sub> - V <sub>OUT</sub>	Input to output voltage difference	12	-	450	V	---
V <sub>OUT</sub>	Overall output voltage regulation	1.14	1.20	1.26	V	13.2V < V <sub>IN</sub> < 400V, R1 = 2.4KΩ, R2 = 0
V <sub>OUT</sub>	Overall output voltage regulation	375	400	425	V	R1 = 2.4KΩ, R2 = 782KΩ
ΔV <sub>OUT</sub>	Line regulation	-	0.003	0.01	%/V	17V < V <sub>IN</sub> < 400V, V <sub>OUT</sub> = 5V, I <sub>OUT</sub> = 0.5mA
ΔV <sub>OUT</sub>	Load regulation	-	1.4	3.0	%	V <sub>IN</sub> = 17V, V <sub>OUT</sub> = 5V, 0.5mA < I <sub>OUT</sub> < 10mA
ΔV <sub>OUT</sub>	Temperature regulation	-1	-	+1	%	V <sub>IN</sub> = 17V, V <sub>OUT</sub> = 5V, I <sub>OUT</sub> = 10mA, -40°C < T <sub>A</sub> < 85°C

LR8

**Electrical Characteristics** (cont.)

(Test conditions unless otherwise specified:  $-40^{\circ}\text{C} < T_A < 85^{\circ}\text{C}$ .)

Sym	Parameter	Min	Typ	Max	Units	Conditions
$I_{OUT}$	Output current limit	10	-	30	mA	$T_J < 85^{\circ}\text{C}$ , $V_{IN} - V_{OUT} = 12\text{V}$
$I_{OUT}$	Output current limit	-	-	0.5	mA	$T_J > 125^{\circ}\text{C}$ , $V_{IN} - V_{OUT} = 450\text{V}$
$I_{OUT}$	Minimum output current	-	0.3	0.5	mA	Includes R1 and load current
$I_{ADJ}$	Adjust output current	5.0	10	15	$\mu\text{A}$	---
C2	Minimum output load capacitance	1.0	-	-	$\mu\text{F}$	---
$DV_{OUT}/DV_{IN}$	Ripple rejection ratio	50	60	-	dB	120Hz, $V_{OUT} = 5\text{V}$
$T_{LIMIT}$	Junction temperature limit	125	-	-	$^{\circ}\text{C}$	---

**Thermal Characteristics**

Package	Power Dissipation @ $T_A = 25^{\circ}\text{C}$	$\theta_{JC}$ $^{\circ}\text{C}/\text{W}$	$\theta_{JA}$ $^{\circ}\text{C}/\text{W}$
TO-92	0.74W	125	170
TO-243AA	1.6W	15	78†
TO-252	2.5W	6.25	50†

Note:

† Mounted on FR4 board, 25mm x 25mm x 1.57mm.

**Functional Block Diagram**

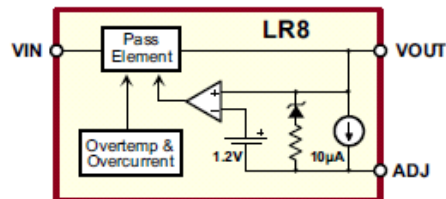

LR8

Typical Application Circuits

Figure 1: High Input Voltage, 5.0V Output Linear Regulator

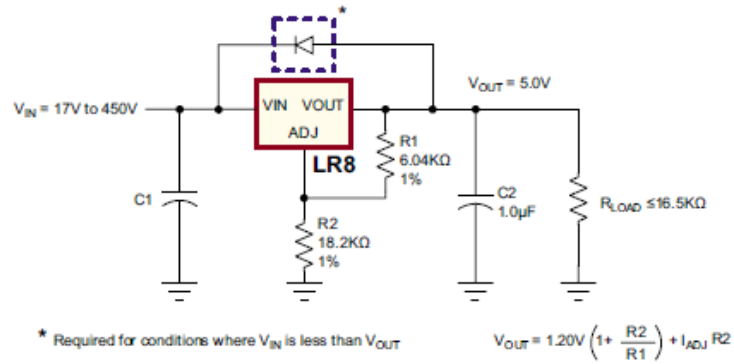

Figure 2: SMPS Start-Up Circuit

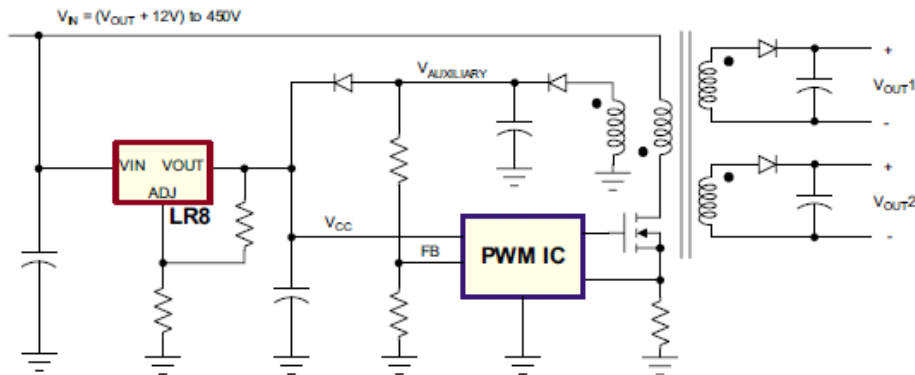
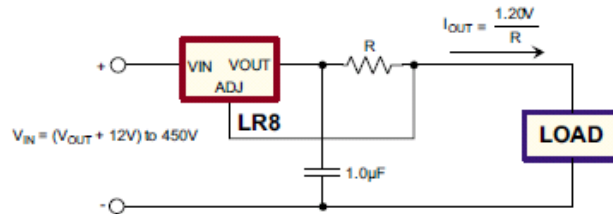
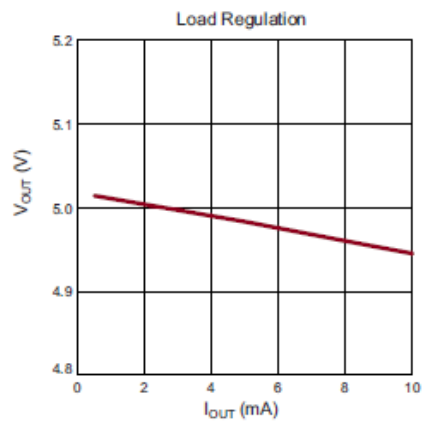
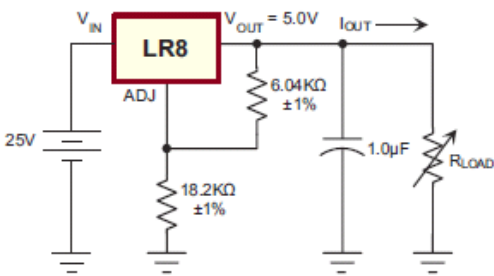
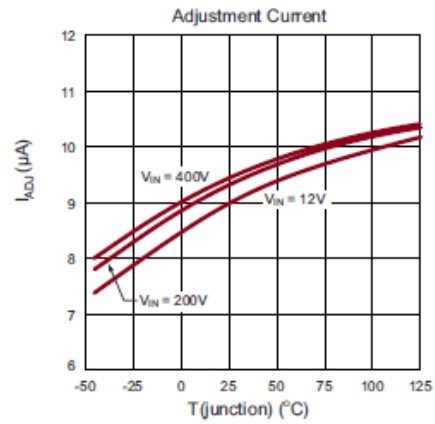
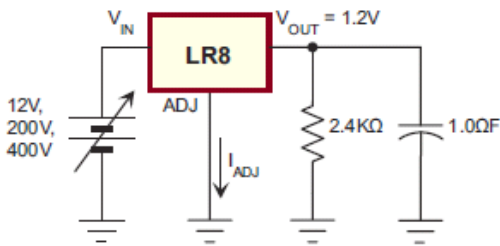
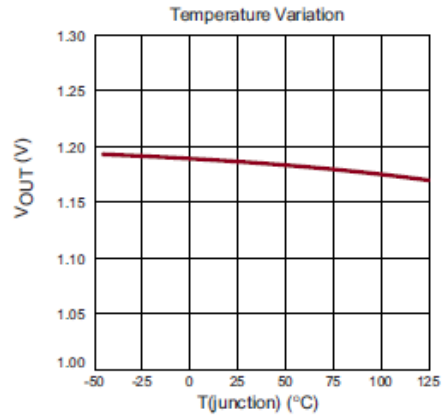
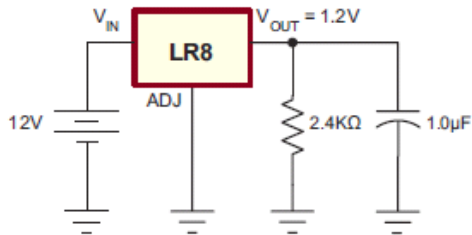

Figure 3: High Voltage Adjustable Constant Current Source



LR8

Typical Performance Curves



LR8

Typical Performance Curves (cont.)

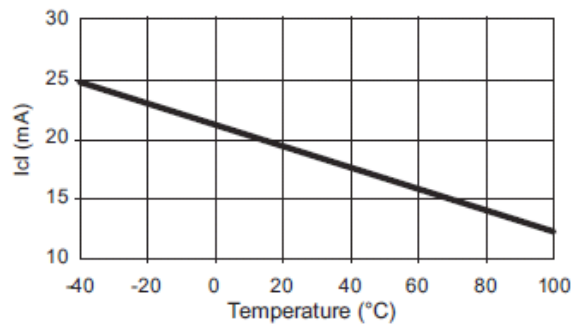
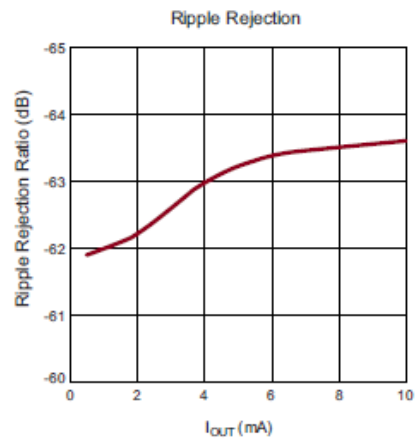
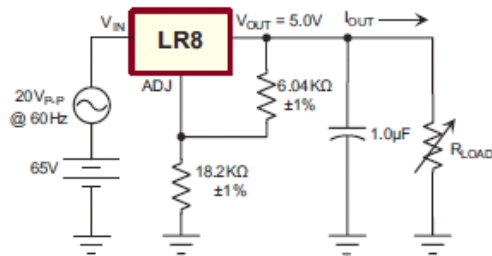
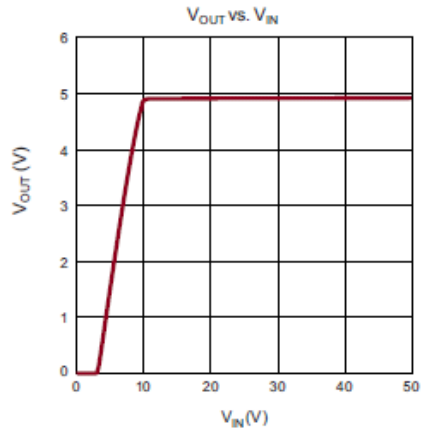
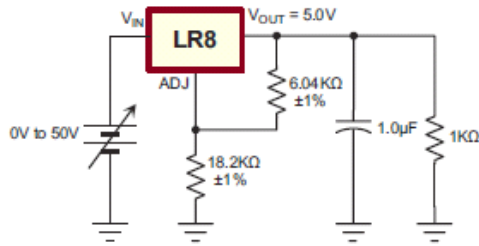

LR8

Typical Performance Curves (cont.)

Load Transient Response

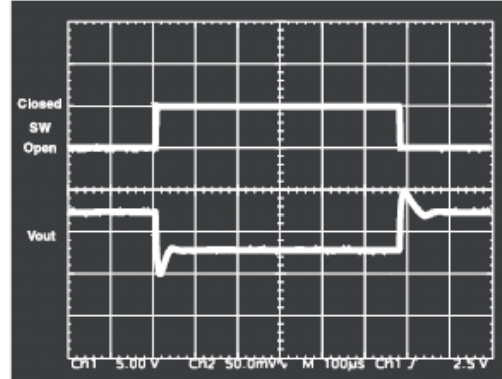
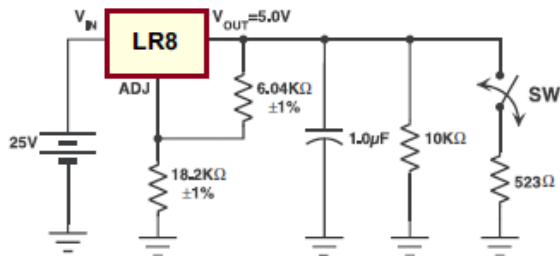

Load Transient Response

Line Transient Response

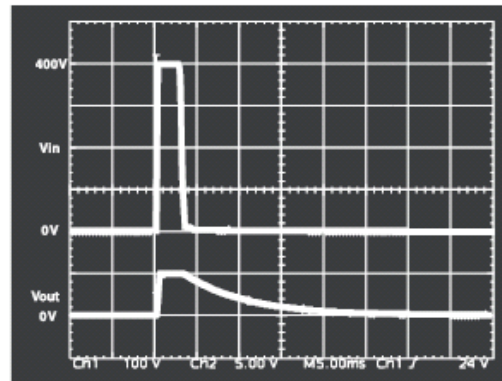
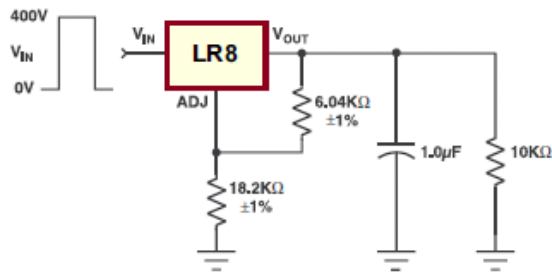

Line Transient Response

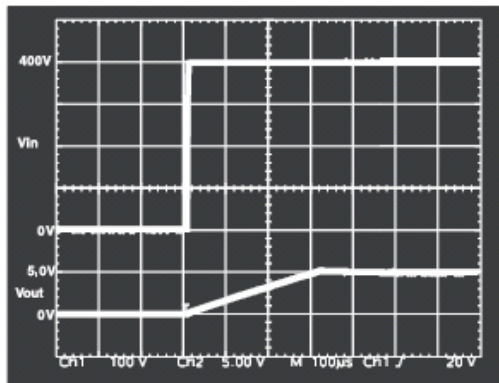

Line Power Up Transient

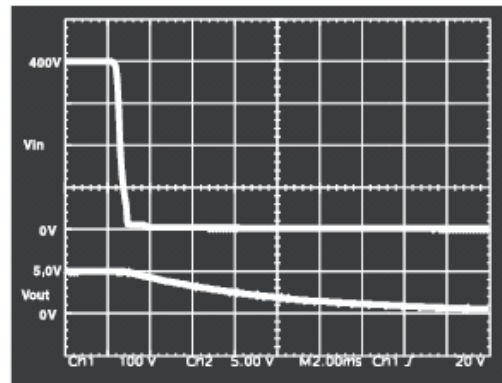

Line Power Down Transient

LR8

### 3-Lead TO-252 D-PAK Package Outline (K4)

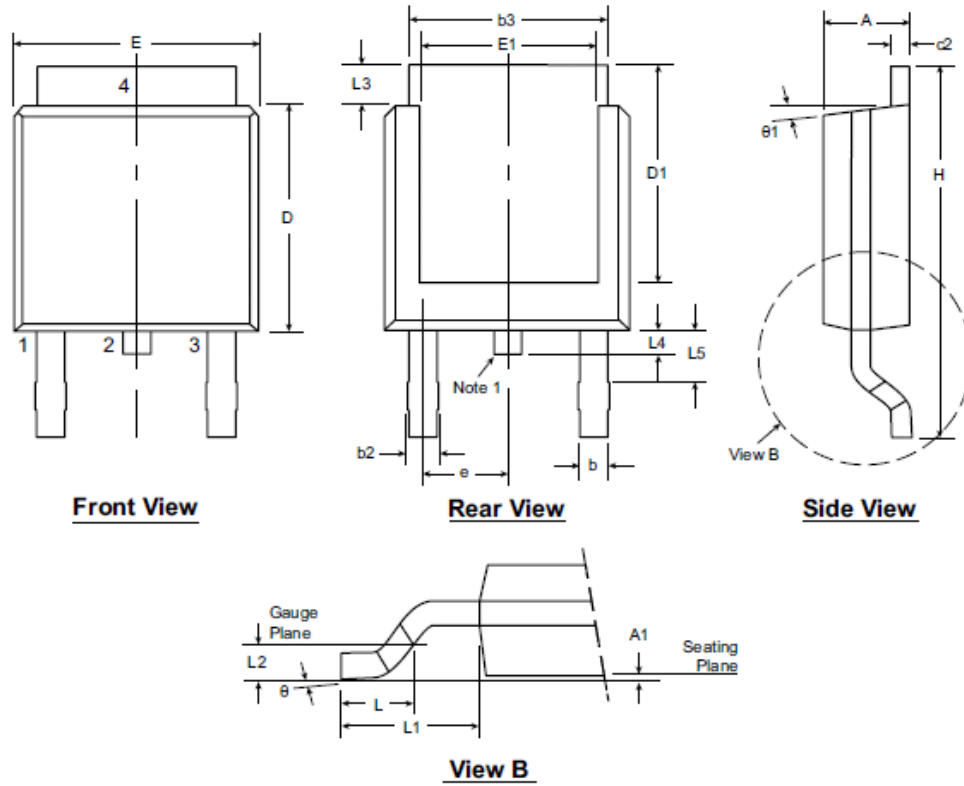

**Note:**

1. Although 4 terminal locations are shown, only 3 are functional. Lead number 2 was removed.

Symbol	A	A1	b	b2	b3	c2	D	D1	E	E1	e	H	L	L1	L2	L3	L4	L5	θ	θ1
Dimension (inches)	MIN	.086	-	.025	.030	.195	.018	.235	.205	.250	.170	.370	.055	.108	.020	.035	-	.045	0°	0°
	NOM	-	-	-	-	-	.240	-	-	-	.090	-	.060	REF	BSC	-	-	-	-	-
	MAX	.094	.005	.035	.045	.215	.035	.245	-	.265	-	.410	.070	-	-	.050	.040	.060	10°	15°

JEDEC Registration TO-252, Variation AA, Issue E, June 2004.

Drawings not to scale.

Supertex Doc. #: DSPD-3TO252K4, Version D081108.

LR8

### 3-Lead TO-92 Package Outline (N3)

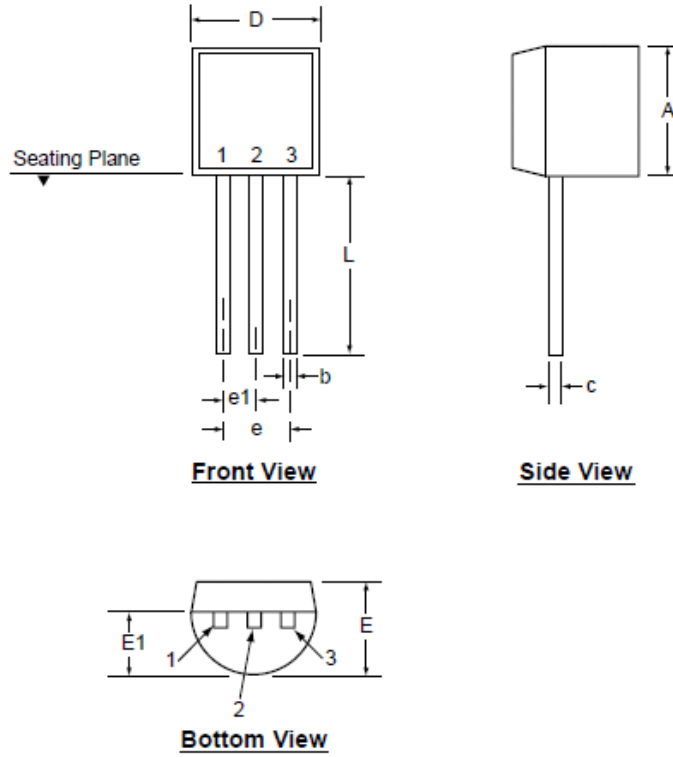

Symbol	A	b	c	D	E	E1	e	e1	L
Dimensions (inches)	MIN	.170	.014†	.175	.125	.080	.095	.045	.500
	NOM	-	-	-	-	-	-	-	-
	MAX	.210	.022†	.022†	.205	.165	.105	.105	.610*

JEDEC Registration TO-92.  
 \* This dimension is not specified in the original JEDEC drawing. The value listed is for reference only.  
 † This dimension is a non-JEDEC dimension.  
 Drawings not to scale.  
 Supertex Doc.#: DSPD-3TO92N3, Version D080408.