

Lucas DP 200 Series fuel injection pump

To remove to fit

20-10

Special tools:

Timing pin PD.246, Lucas fuel injection pumps

General description

Caution: Do not release the nut (C2) from the fuel injection pump. Illustration (C) shows the nut in position when the fuel pump is fitted to the engine. The fuel pump hub is fitted to the shaft in the factory to ensure that the fuel pump is in the correct position for timing. If the nut is removed and the hub moves, the hub will need to be accurately fitted to the pump by use of specialist equipment before the pump can be fitted to the engine.

The manufacturer fits the hub (A2) to the pump to ensure very accurate timing. Engines that have this arrangement have the drive gear fastened to the hub instead of to the shaft of the pump.

The hub is permanently mounted onto the drive shaft by the pump manufacturer to allow the pump timing to be set accurately when the engine is in service.

To prevent incorrect adjustments to the engine timing by rotation of the fuel pump, the mounting flange (B1) has holes instead of slots.

Accurate timing of the pump to the engine is by a pin (C1) used to align the fuel pump gear and the hub (C4), with a hole in the body (C3) of the fuel pump. The gear is passed over the pin and fastened to the hub with four fasteners (C6).

Note: On the latest engines with belt driven coolant pumps, four tamper proof fasteners retain the fuel pump gear. Special tools to remove these fasteners are available at your Perkins distributor.

Caution: A new fuel injection pump may be supplied with the pump shaft in the locked position. The drive shaft of the pump must not be turned without the spacer (B2) in position under the locking screw (B3).

The fuel injection pump has a locking screw (A3) and (B3) and a spacer (B2). The locking screw prevents the rotation of the drive shaft.

An "O" ring (A1) is fitted into a groove in the pump flange. This "O" ring is fitted instead of a joint between the pump flange and the timing case.

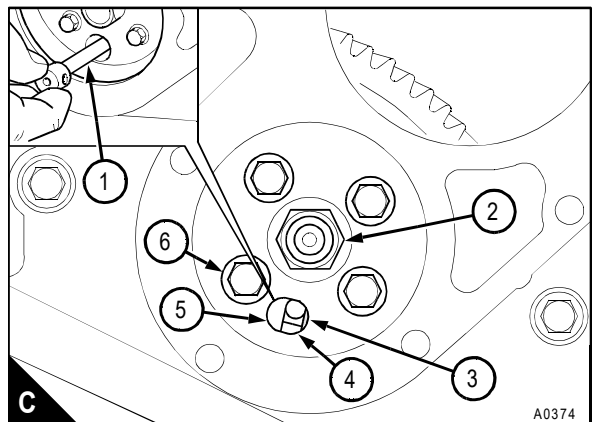
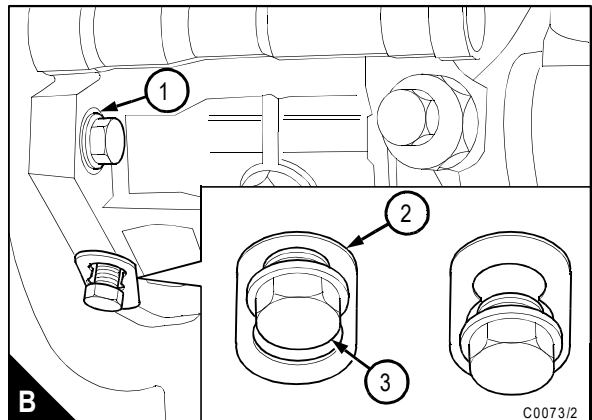
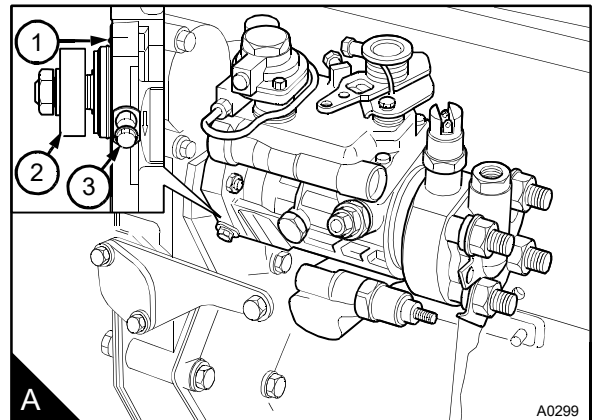

To remove

Before the crankshaft is turned or the pump is fitted, put the spacer (A1) into position under the locking screw (A2) to ensure that the **pump drive shaft is released**.

- 1 Disconnect the battery before the fuel injection pump is removed from the engine.
- 2 Set the engine to TDC on the number 1 cylinder on the compression stroke, [see operation 17-1](#) or , [see operation 17-2](#).
- 3 Remove the gear cover from the cover of the timing case. For gear driven coolant pumps: Remove the coolant pump, [see operation 21-3](#).
- 4 Insert the timing pin (B1) through the hole (B5) in the fuel pump gear and the slot of the hub (B4). Push the pin fully into the hole (B3) in the body of the fuel pump. If the pin can be fully inserted then the pump timing is correct. There should be no resistance when the pin is inserted.

Caution: Use a second spanner to prevent movement of the high-pressure outlet when the union nut for each high-pressure pipe is released.

- 5 Remove the pipes, the cables and the connections for the cold start device and the electrical stop solenoid from the fuel pump.

Cautions:

- Do not rotate the crankshaft when the pump is not on the engine; the loose fuel pump gear may damage the timing case. If it is necessary to rotate the crankshaft, fit the fuel pump temporarily to ensure that the gear is in the correct position. If the fuel pump is fitted temporarily in order to rotate the crankshaft, **the locking screw (A2) must be released** and a spacer (A1) fitted.
- Do not release the nut (B2) from the fuel injection pump. The fuel pump hub is fitted to the shaft in the factory to ensure that the fuel pump is in the correct position for timing. If the hub is removed, the hub will need to be accurately fitted to the pump by use of special equipment available to Perkins distributors.

- 6 Remove the four fasteners (B6) and release the fuel pump gear from the hub of the fuel injection pump.

- 7 Remove the nuts from the flange of the fuel pump and remove the pump.

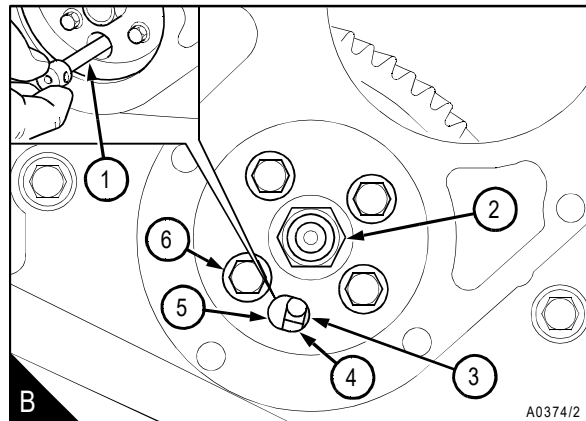
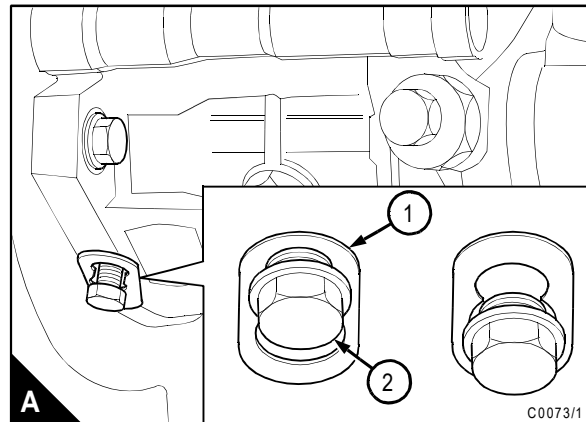

To fit**Cautions:**

- The engine must be set to TDC number 1 cylinder, compression stroke before the pump is fitted. If the crankshaft needs to be rotated, the pump must be fitted temporarily, or the loose gear could damage the timing case.
- The drive shaft of the pump must not be rotated without the spacer (A1) in position under the locking screw (A2). If the drive shaft is rotated with the locking screw tightened on to the shaft, the drive shaft will be damaged.

1 Inspect the "O" ring (B1) in the pump flange and, if necessary, fit a new "O" ring.

2 Lightly lubricate the "O" ring with clean engine lubricating oil and put the pump into position on the timing case.

3 Put the fuel pump in position on the three studs and fit the flange nuts.

4 Fit the setscrew and nut of the support bracket. Ensure that force is not applied to the fuel pump when the support bracket is fitted.

5 Tighten the flange nuts of the fuel pump to 28 Nm (20 lbf ft) 2,8 kgf m.

Caution: Do not remove the nut (C2) from the shaft of the fuel injection pump. The fuel pump hub is fitted to the shaft in the factory to ensure that the fuel pump is in the correct position for timing. If the hub is removed, the hub will need to be accurately fitted to the pump by use of special equipment available to Perkins distributors.

6 Put the fuel pump gear onto the hub of the fuel pump. The fasteners (C6) for the fuel pump gear should be in the centre of the slots to allow for the removal of the backlash. Tighten the setscrews finger tight.

Note: The fuel pump gear will only fit in one position. The gear is fitted with the letters C and M at the front.

7 Insert the timing pin (C1) through the hole (C5) of the fuel pump gear and the slot of the hub (C4) until it can be pushed fully into the hole (C3) in the body of the fuel pump. If the timing pin cannot be pushed into the pump body, check that the engine is correctly set at TDC on the number 1 cylinder, see operation 17-1 or , see operation 17-2.

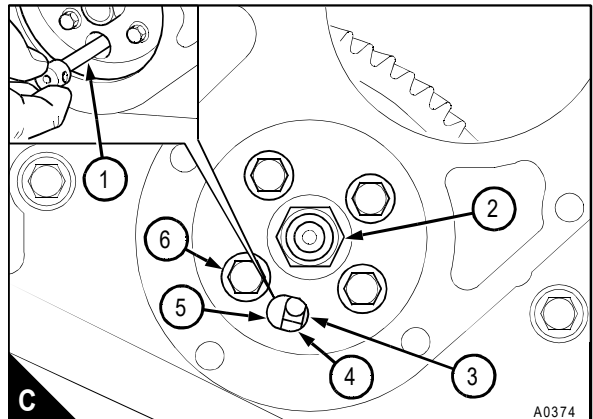
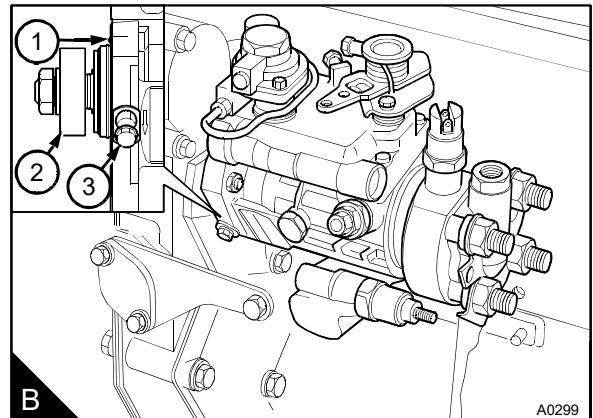
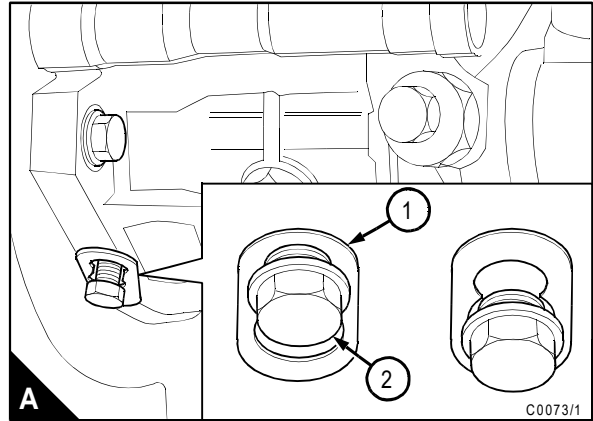

Continued

Caution: The fuel pump gear must be fitted to the engine before the crankshaft is rotated.

8 Carefully turn the gear counter-clockwise, by hand (A1), to remove the backlash between the idler gear and the fuel pump gear. Do not rotate the crankshaft or the fuel pump shaft. Tighten the setscrews for the fuel pump gear to 28 Nm (20 lbf ft) 2,8 kgf m.

9 Remove the timing pin.

10 Fit the gear cover to the cover of the timing case. For gear driven coolant pumps: Fit the coolant pump, see operation 21-3.

Caution: Do not tighten the union nuts of the high-pressure pipes more than the recommended torque tension. If there is a leakage from the union nut, ensure that the pipe is correctly aligned with the atomiser inlet. Do not tighten the atomiser union nut more, as this can cause a restriction at the end of the pipe. This can affect the fuel delivery.

11 Fit all the pipes. Connect the control rod of the fuel injection pump. Fit the cables and connection for the cold start device and electrical stop solenoid to the pump. Ensure that a spanner is used to prevent movement of the pump outlets when the high-pressure pipes are fitted and tighten the union nuts to 22 Nm (16 lbf ft) 2,2 kgf m.

12 Eliminate air from the fuel system, see operation 20-12.

13 Fit the cylinder head rocker cover.

14 Operate the engine and check for leakage. With the engine at the normal temperature of operation, check that the idle speed and the maximum no-load speed are correct, see operation 20-11.

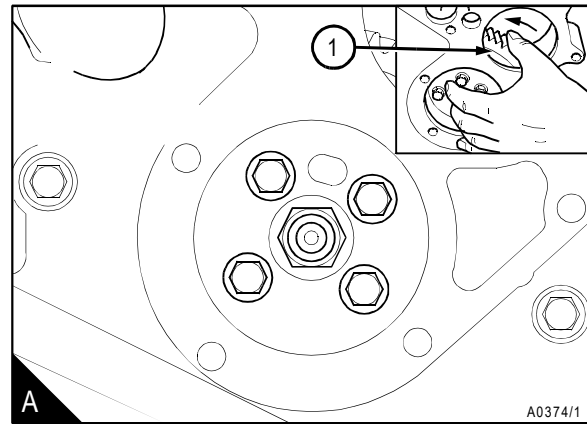

To adjust

20-11

The engine conforms with USA (EPA/CARB) stage 1 and EEC stage 1 emissions legislation for agricultural and industrial applications.

The idle or maximum speed settings must not be changed by the engine operator, because this can damage the engine or the transmission.

Specialist equipment, which is available at your Perkins Distributor, is needed to adjust the idle or maximum speed settings. The warranty of the engine can be affected if the seals on the fuel injection pump are broken during the warranty period by a person who is not approved by Perkins.

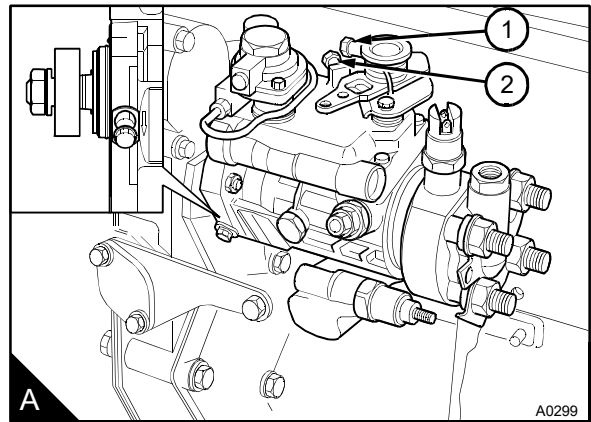

1 Operate the engine until it reaches its normal temperature of operation and check the idle speed. If necessary, adjustment can be made by the outer adjustment screw (A2). Release the lock nut and rotate the adjustment screw clockwise to increase the speed, or counter-clockwise to decrease the speed. When the speed is correct, tighten the lock nut. The setting of the idle speed can change for different applications. Normally the correct speed will be given in the manufacturer's handbook for the application. If it is not given, refer to your nearest Perkins distributor.

Caution: *The setting for the maximum no load speed can change for different applications. For the correct maximum no-load speed, check the emissions data plate fitted to the left side of the cylinder block before any adjustment is made to the maximum no load speed.*

2 With the engine at its normal temperature of operation, check the maximum no load speed. A typical maximum no load speed is 2860 rev/min. If necessary, this speed can be adjusted by the inner adjustment screw (A1). Release the lock nut and rotate the adjustment screw counter-clockwise to increase the speed or clockwise to decrease the speed. When the speed is correct, tighten the lock nut and seal the screw.

The person who fits the pump must ensure that the adjustment screw is suitably sealed against interference after it has been set initially.