

Newmar

Technical Service Training

Technician Training
By
Evans Tempcon Inc.



TEMPCON
ISO 9001
Registered



TEMPCON
ISO 9001
Registered

TYPICAL PUSHER CHASSIS WITH FACTORY SUPPLIED A/C PARTS VERSUS EVANS SUPPLIED PARTS

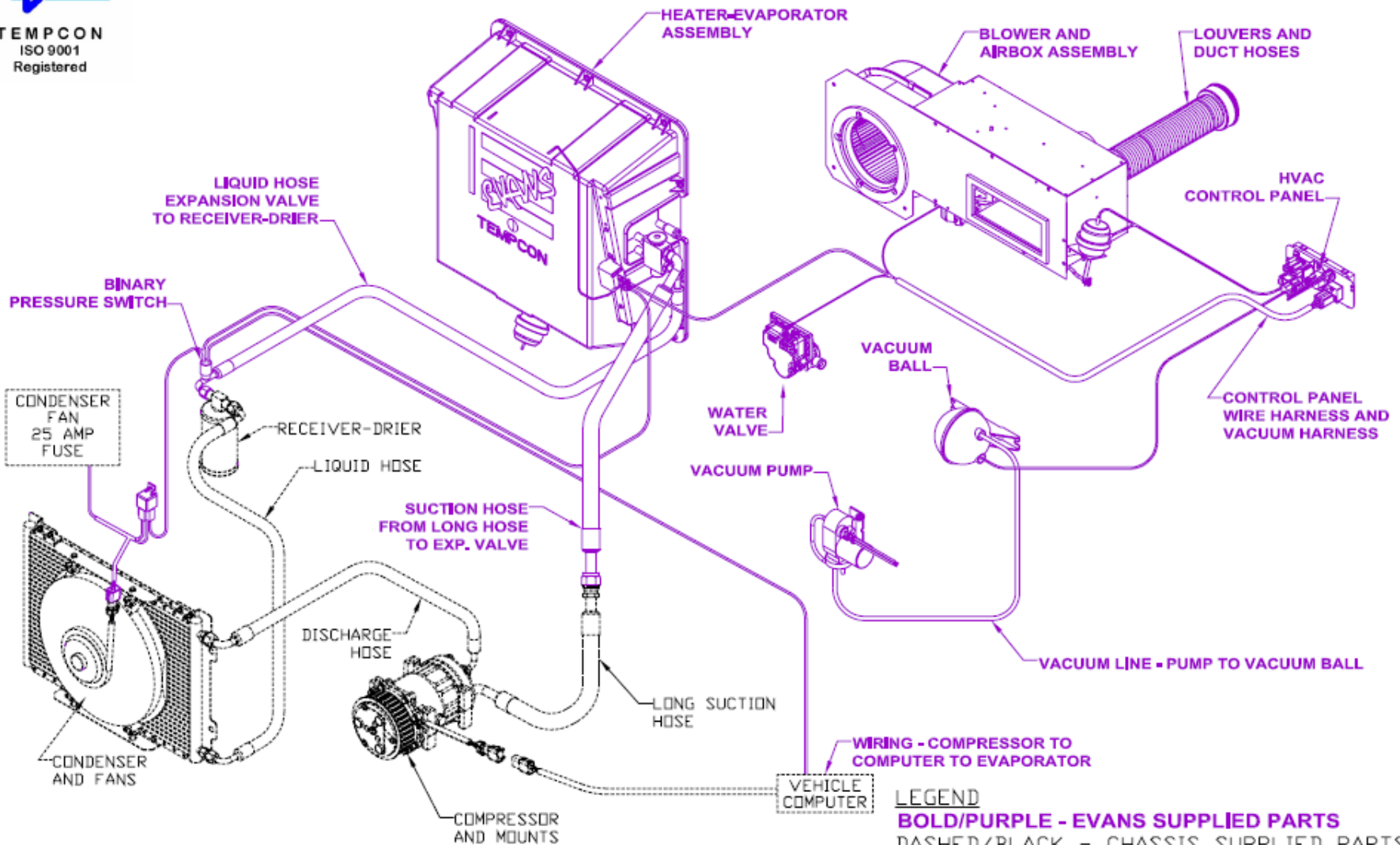

NOTE: On Freightliner and Spartan side radiator/condensers, the pressure switch on the discharge hose that controls the hydraulic fan is chassis supplied. Chassis computer must be enabled to use this switch. There is no Evans supplied electric fan. On Workhorse Pusher there is a high pressure switch at the compressor supplied with chassis.



TEMPCON
ISO 9001
Registered

2005 M.Y. CHASSIS AND BEYOND FORD CHASSIS SUPPLIED PARTS VERSUS EVANS SUPPLIED PARTS

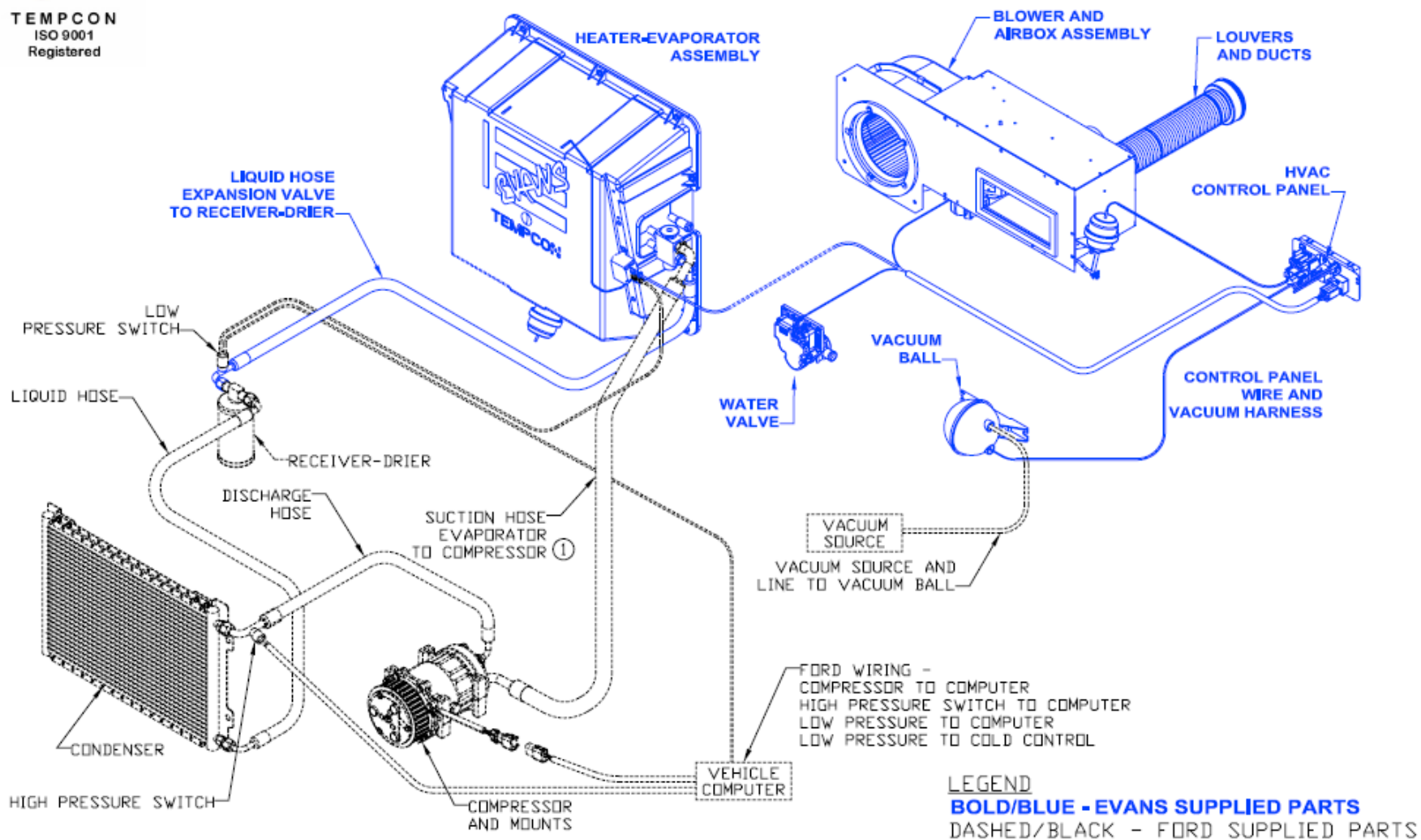

1. Gulfstream: After May, 2006 this part is Evans supplied.

A/C SYSTEM OPERATIONAL CHECK

The following is an A/C system "Field Test" and Evaluation Procedure to be used by service personnel. This procedure can be used to determine if an Evans A/C system is performing properly, and contains the correct refrigerant charge. The performance guidelines shown are approximate, and subject to many operational variables. Ambient temperature must be 50 deg F or above to accurately test for A/C performance.

1. Park the vehicle and set the engine speed at 1500 RPM.
2. Set the HVAC controls to "MAX A/C", the blower at HIGH speed, and the temperature control dial to the coldest setting.
3. Visually verify that the A/C compressor clutch is engaged, and the compressor is operating. Verify that the heater coolant valve is closed, and the heater coil tubes are neutral or cool to the touch.
4. The suction hose fitting (at the evaporator outlet) should be cold to the touch. This fitting may sweat or even frost slightly. The liquid hose fitting (at the evaporator inlet) should be warm to the touch.
5. Chilled air should be discharged from the supply louvers in the cab. After 3-5 minutes of A/C operation the system should begin to cool.
6. Air inlet / outlet temperature differentials are greatly affected by ambient temperature and relative humidity. In cool ambient conditions, differentials smaller than 30 degrees may be seen. Air can only be chilled to a certain level, and then the A/C compressor will cycle off to prevent evaporator freeze-up. High humidity may also result in smaller differentials; a large amount of cooling capacity is required to dehumidify the air, as well as cool it. See Estimated A/C Performance Guidelines for acceptable ranges of performance.

ESTIMATED A/C PERFORMANCE GUIDELINES **REQUIRED INFORMATION**

1. PARK THE VEHICLE AND SET THE ENGINE SPEED TO ~1500 RPM.
2. SET THE HVAC CONTROLS TO "MAX A/C", THE BLOWER SET AT HIGH SPEED, AND THE TEMPERATURE CONTROL DIAL TO THE COLDEST SETTING THEN ALLOW THE SYSTEM TO STABLIZE (5 - 10 MINUTES).
3. MEASURE OR FIND THE AMBIENT TEMPERATURE AND HUMIDITY THE DAY OF SERVICING THE RV AND RECORD.
4. MEASURE THE TEMPERATURE OF THE CAB AIR ENTERING THE RECIRCULATION INLET AIR GRILLE (i.e. "Max A/C" ventilation mode) AND RECORD.
5. MEASURE THE TEMPERATURE OF THE AIR DISCHARGING THE LOUVER CLOSEST TO THE HVAC UNIT.
6. SUBTRACT THE DISCHARGE AIR TEMPERATURE VALUE FROM THE INLET AIR TEMPERATURE VALUE TO CALCULATE THE "INLET/OUTLET AIR TEMPERATURE DIFFERENTIAL AND THEN RECORD THE VALUE.
7. RECORD THE LOW AND HIGH SIDE REFRIGERANT GAUGE PRESSURES.
8. COMPARE YOUR RECORD WITH THE "**ESTIMATED A/C PERFORMANCE GUIDELINES**" SECTION.
9. IF SYSTEM VALUES FALL WITHIN ESTIMATED AC PERFORMANCE GUIDELINES THEN SYSTEM IS FUNCTIONING AS DESIGNED.
10. IF SYSTEM VALUES DO NOT FALL WITH THE GUIDELINES THEN GO BACK TO THE "TECHNICAL SUPPORT" PAGE AND CLICK ON "**HVAC SYSTEM TROUBLESHOOTING GUIDELINES**" AND ACCESS THE "**AC TROUBLESHOOTING GUIDE**".

ESTIMATED A/C PERFORMANCE GUIDELINES

The following performance guidelines are based on test conditions outlined under "A/C System Operational Check". Variables such as engine speed, condenser airflow, sun load, blower motor speed, and chassis voltage will all affect A/C system performance.

Air Temperature (F) Entering A/C Unit	Inlet - Outlet Air Temperature Differential**	
	FRESH OR RECIRCULATED	HIGH HUMIDITY
50	5-10	5-10
60	10-20	10-15
70	20-25	15-20
80	25-30	20-25
90	25-35	20-30
100	30-35	25-30
110	35-40	30-35

** The outlet louver closest to the A/C unit usually discharges the coldest air. The warmest inlet air temperature (fresh or recirculated) should also be used for the Differential calculation.

A/C System Operating Pressures		
Ambient Air Temp (F) Entering Condenser	Suction Pressure (PSIG) @ Evaporator Outlet	Discharge Pressure (PSIG) @ Compressor Outlet
50	5-15	75-125
60	5-15	100-150
70	10-20	125-175
80	10-20	150-225
90	15-25	175-250
100	15-25	200-275
110	15-30	225-325



TEMPCON
ISO 9001
Registered

SERVICE TIP

USE ONLY VIRGIN R134A REFRIGERANT

1. RECLAIMING REFRIGERANT, EVACUATING THE AC SYSTEM AND CHARGING WITH PROPER AMOUNT OF NEW REFRIGERANT SOLVES MANY AC COMPLAINTS.
2. SOME REFRIGERANT LOSS WILL OCCUR IN ONE YEAR'S TIME AND THIS IS RECOGNIZED AS NORMAL. VIBRATION, HOSE POROSITY AND GENERAL CONSTRUCTION OF THE SYSTEM MAKE A LEAK PROOF SYSTEM NEARLY IMPOSSIBLE.
3. THE SAE DEFINED ACCEPTABLE LEAK RATE IS 0.5 OUNCES OR 14 GRAMS PER YEAR AND IS USED TO DETERMINE THE SENSITIVITY OF ELECTRONIC PROBE TYPE LEAK DETECTORS.
4. REFRIGERANT DYE IS VERY USEFUL IN DETECTING REFRIGERANT LEAKS IF USED PROPERLY. OTHERWISE IT CAN LEAD TO CONTINUED FALSE DIAGNOSISES:
 - a) USE A WET RAG TO CLEAN OR REMOVE ALL DYE DISCOVERED DURING INITIAL EXAMINATION.
 - b) PERFORM THE **"AC SYSTEMS OPERATIONAL CHECK PROCEDURE"** LISTED IN THE TECHNICAL SUPPORT SECTION OF THE WEBSITE.
 - c) RE-EXAMINE AC SYSTEM FOR ANY NEW DYE THAT MIGHT HAVE APPEARED.
 - d) IF NEW DYE IS DISCOVERED THEN PERFORM THE REPAIR(S). CLEAN ALL DYE AGAIN SO THE NEXT TECHNICIAN DOES NOT ASSUME THAT THIS IS A NEW LEAK OR MIS-DIAGNOSE THE PROBLEM.
5. **EVANS DOES NOT RECOMMEND OR ENDORSE THE USE OF "STOP LEAK" or "LEAK SEALING" PRODUCTS.**



TEMPCON
ISO 9001
Registered

R134a
REFRIGERANT ALLOWANCE CHART
(BASED ON ACTUAL SYSTEM REFRIGERANT CHARGE CAPACITY)

Revised 10/18/11

701 ANN ST. N.W.
GRAND RAPIDS, MI 49504

RV APPLICATIONS

FRONT ENGINE CHASSIS	CHARGE
GM (Chevy) P-30, L-19, L-29, L-65	2.75 Lbs.
GM (Chevy) P-12 w/Parallel-Flow Condenser	2.0 Lbs.
Workhorse before '05 model except W-24	2.75 Lbs. (1)
Workhorse - all models with black Behr condenser and two fans	2.00 Lbs.
Workhorse W22/W24 w/Multi-flow Condenser and no fans	1.5 Lbs.
Ford E-33 w/Serpentine Condenser	2.25 Lbs.
Ford F-53 w/Black Fin & Tube Condenser	2.75 Lbs.
Ford F-53 w/Silver Multi-flow Condenser(starting with MY2012)	1.75 Lbs
Ford V-10 Super Duty w/6mm Condenser	2.75 Lbs.
FTL Front Engine Diesel w/Parallel-Flow Condenser	1.5 Lbs.
FTL Front Engine Diesel w/remote mounted condenser and fan	2.25 Lbs.

(1) For W22 without an auxiliary condenser, charge would be 1.75 lbs and performance would be reduced.

REAR ENGINE DIESEL PUSHER CHASSIS	CHARGE
Front-mounted Step well Parallel-Flow Condenser	2.00 Lbs.
Spartan (Fleetwood Heritage only)	5.25 Lbs.
Spartan Rear-Side Mounted Condenser (>500 HP)	4.5 Lbs.
Spartan Rear-Side Mounted Condenser (<500HP)	3.0 Lbs.
Spartan Rear-Side Mounted Condenser (Full cover -2011 or later)	5.5 Lbs
Spartan Rear Std Center Mounted Condenser	3.0 Lbs.
Spartan Front Mounted Evans Fin & Tube Condenser	3.5 Lbs.
Spartan Mid-Engine Chassis	2.5 Lbs.
Spartan Front Mounted Parallel Flow Condenser	2.5 Lbs.
FTL Rear Mounted Evans Fin & Tube Condenser	4.5 Lbs.
FTL Remote Mounted Parallel Flow Condenser w/12" Elec Fan	2.75 Lbs..
FTL Rear Mtd Large Parallel Flow Cond w/Side Radiator w/No Elec Fan	4.0 Lbs.
FTL Front Mounted Evans Fin & Tube Condenser	3.5 Lbs.
Workhorse Pusher Front Mounted Fin & Tube Condenser	3.0 Lbs.
Roadmaster (Monaco/Holiday Rambler) Rear Condenser	4.0 Lbs

REFRIGERANT METERING VALVE OR THERMOSTATIC EXPANSION VALVE (TXV) FUNCTION TEST

TXV Operation:

The Thermostatic Expansion Valve or TXV is an interactive device that senses pressure and temperature then adjusts refrigerant flow to maintain a given superheat. Do not replace this device unless its function has been properly tested.

TXV Function Test:

- 1) A/C system is fully charged.
- 2) Blower motor set for high speed.
- 3) Engage compressor and allow A/C system to stabilize.
- 4) After 5- 10 minutes observe low side refrigerant operating pressures and record.
- 5) Change the blower motor speed to low and continue to watch the low side pressure. The pressure should drop ~3 – 4 Psig depending on the heat load in ~1 – 2 minutes.
- 6) Repeat this procedure 2 – 3 more times.
- 7) If the low side pressure can be influenced by changing the blower motor fan speed then the TXV is responding in the changing of the evaporator's heat load as designed.

Refrigerant Flow

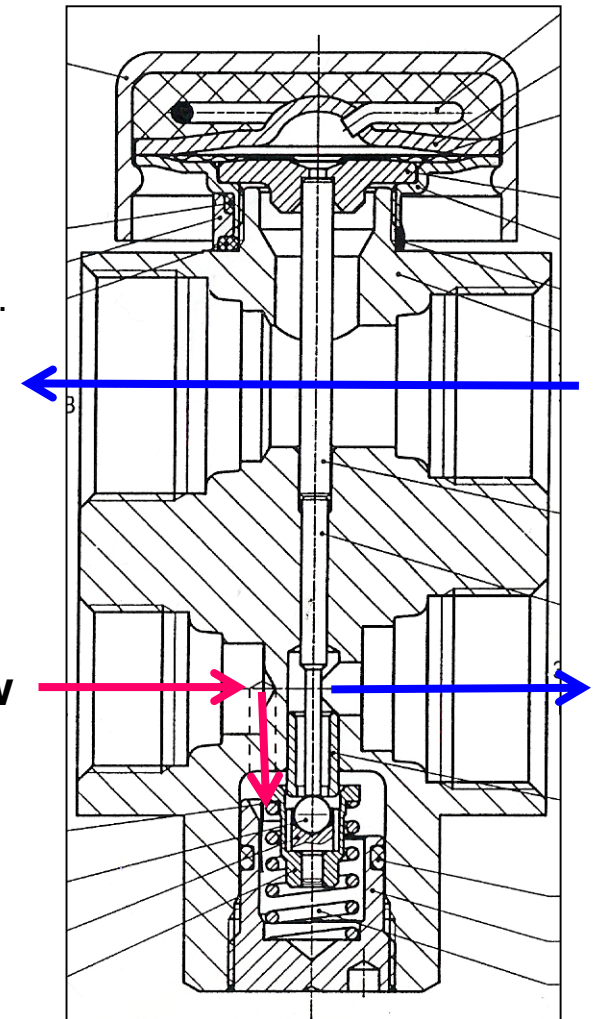

WEB BASED TECHNICAL SUPPORT



Evans Tempcon
ISO 9001 REGISTERED

September 8, 2005

*Supplying Climate Control
Systems to the Vehicle Market
for Over Half a Century!*

Phone - 616.361.2681 / Fax - 616.361.9646

HOME
ABOUT US
OUR PRODUCTS
TECHNICAL SUPPORT
SERVICE CENTERS
OWNERS RESOURCES
CONTACT US



Technical Support (Trouble Shooting, Diagnosis and Repair)

I. Dash Heater-A/C Trouble Shooting, Diagnosis And Repair

[HVAC System Troubleshooting Guides](#)

TROUBLESHOOTING

Automatic Temp Control 2000 and Dual Zone ATC 2000 Control Systems
Automatic Temp Control (ATC) System
Dual Zone Dual Blower Rotary Control Systems
Dual Zone Single Blower Rotary Control Systems
Rotary-Action Control System
Slide-Action / Push Button Control System

[Refrigerant Charge Information - R134A Systems](#)

[Refrigerant & Service Recommendations](#)

[System Oil Allowances - Individual Evans A/C Components](#)

[A/C Fitting Torque Guide](#)

[Assembly Instructions for Metal to Rubber \(Compression\) Fittings](#)

[Evans Versus Chassis Supplied Heater A/C Parts](#)

II. A/C System Testing and Evaluation

[A/C Systems Operational Check](#)

[Estimated A/C Performance Guidelines](#)

[Road Test GM/Workhorse Chassis with Chassis Supplied Low Pressure Switch](#)

[Click Here](#) to return to the Tech Support Home Page

WEB BASED TECHNICAL SUPPORT

January 9, 2006



Evans Tempcon

ISO 9001 REGISTERED

*Supplying Climate Control
Systems to the Vehicle Market
for Over Half a Century!*

Phone - 616.361.2681 / Fax - 616.361.9646

- HOME
- ABOUT US
- OUR PRODUCTS
- TECHNICAL SUPPORT
- SERVICE PARTS
- SERVICE CENTERS
- OWNERS RESOURCES
- CONTACT US

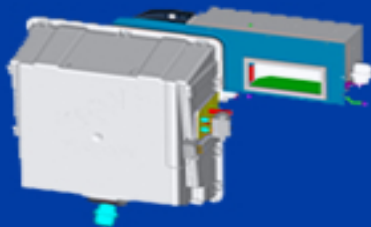

Cable And Electric Rotary Control Systems

[Click Here](#) to Download all of the files listed below as a compressed zip file!



All files require a PDF Viewer to View

[Electronic Coolant Valve Troubleshooting Guide \(2002 and later\)](#)

[Electrical Troubleshooting Guide](#)

[Electrical Schematics](#)

[Vacuum Troubleshooting Guides](#)

[Vacuum Logic Diagrams](#)

[A/C Troubleshooting Guide](#)

[Heater Troubleshooting Guide](#)

[Defroster Troubleshooting Guide](#)

[Cable Operated Coolant Valve](#)

[Electronic Coolant Valve Troubleshooting Guide \(2002 and prior\)](#)

[In-Line Coolant Filter Kit](#)

ALLOWS YOU
TO DOWNLOAD
FILES IN PDF
FORMAT

COOLANT
VALVE IS NOT
FUNCTIONING

[Return to HVAC System Trouble Shooting Guides
Technical Support Home Page](#)

**EVANS ELECTRONIC VALVE AND
ELECTRONIC TEMPERATURE CONTROL TROUBLESHOOTING GUIDE**
for systems equipped with the EVANS electric coolant valve and control system.



This guide is intended for use with the EVANS electronic coolant valve shown at left and its control system.

For other electronic coolant control systems, refer to [Cable-less Electronic Valve – 2002 and Prior](#).

For other HVAC system components, diagnoses, and repair, refer back to the [Cable and Rotary Control Systems](#) Menu for the appropriate topic.

NOTICE

Read the entire troubleshooting guide and familiarize yourself with the procedures before attempting any of the procedures described in this document.

VALVE IDENTIFICATION

There are two types of actuators on the valves that Evans supplies as shown in the illustration below. The significant difference in the valves is the arrangement of the terminals in the connector housing on the actuator. Old style valves used from 2002 to 2005 have a distinct “T” pattern as shown on the right and the manufacturer’s logo “Seitz” on the actuator, while newer valves used from 2006 and later have the terminals located in the four corner positions of the connector housing, as seen on the left, and the actuator manufacturer’s logo “CEI” on the cover.

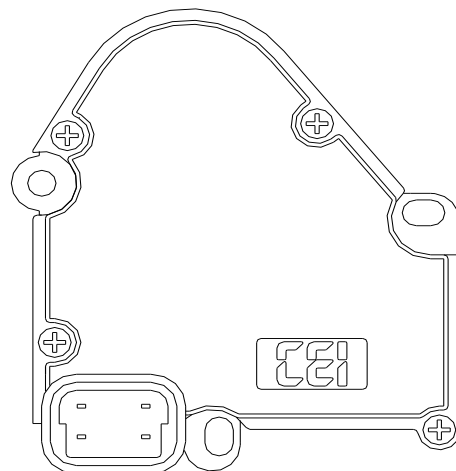

NEW

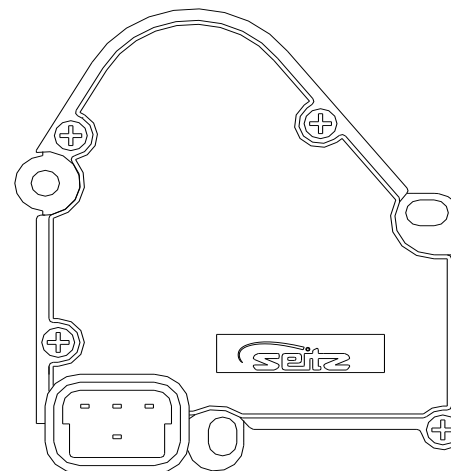

OLD

Inspect the main harness valve connector and valve pin pattern to ensure the correct valve was previously installed on the vehicle. The connector pattern should have three wires in a straight line for the old style valve (on left below), not a 3 corner or 'L' pattern for the new valve (on right below). If a new style valve has been installed on a vehicle with an older style harness, a jumper harness needs to be installed between the harness and the valve to correctly orient the terminals for the new style valve. Contact your service parts representative if it is determined a jumper harness is required and you do not have one.

Evans service parts kit # RV218999 is intended for use to replace an old style valve with a new valve and contains the necessary jumper harness along with the valve. Service parts kit # RV218967 is intended for systems that have the new style valve and harness and does not contain the jumper harness for older systems.

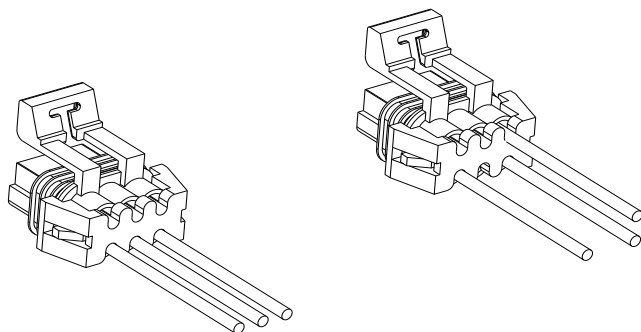

OLD

NEW

When plugging the connector from the harness into the valve connector socket, **be sure to push the connector straight into the socket and do not rock the connector** as it is inserted as this could cause the pins in the connector to become bent or misaligned.

SYSTEMS CHECK

Before attempting to troubleshoot, verify that the HVAC system (other than temperature control) is operating correctly. With the vehicle running, test-operate the system and check the following:

- *Blower Motor and 4 operating speeds
- *Mode selector switch and air distribution system
- *A/C system (engine-driven compressor, refrigeration system, etc.).

1. With the vehicle running and the A/C system engaged (Blower turned on, Mode selector set to "MAX A/C", Temperature dial rotated to full cool), clamp off the heater inlet hose to see if the A/C system is cooling properly. Test the A/C performance using the A/C Systems Operational Check and Estimated A/C Performance Guidelines. Once this has been determined (and corrected if necessary), remove the clamp from the coolant inlet hose.

- If a significant loss in cooling capacity in the A/C system occurs when the clamp is removed, shut the vehicle off, and carefully follow the step-by-step directions listed below for troubleshooting the coolant control system. If a problem is found, repair/correct the fault before proceeding to the next step. When troubleshooting electric and/or electronic components, care must be taken to prevent component damage while inspecting, using a test meter, light, etc. If questions or concerns arise during the troubleshooting process, contact Evans Tempcon for telephone assistance **before** proceeding further (1-800-878-7147).

COMPONENT TESTING

- 1. The temperature control is located in the center of the HVAC system control panel. Rotate the potentiometer knob to verify smooth operation. The knob should rotate freely from the cool stop (blue), to the warm stop (red). Do not force the knob to rotate past the cool or warm stops. Doing so will cause irreparable damage to the potentiometer control. If the knob can be rotated past the internal stop at the full cool and full heat positions, the potentiometer must be replaced before any further valve diagnostics is done.
- 2. Locate the electronic coolant valve assembly in the heater base unit compartment, near the Evans Heater-Evaporator unit (on the firewall). The electrical connector is located on the top of the actuator housing.
- 3. Verify that the port on the outlet side of the valve is connected to the inlet tube on the heater coil. A flow direction indicator is located on the side of the valve to help distinguish inlet and outlet ports. Also, the inlet side of the valve is always on the same side as the harness connector. New valves also have tape wrapped around the inlet port that clearly identifies the inlet port (see the illustration at the beginning of this guide). The coolant supply hose from the engine connects to the inlet side of the valve.
 - **NOTE: The electronic coolant valve is a "directional" valve, and must be correctly installed, or it will not function properly.** Coolant valves installed with the coolant flow reversed will leak coolant past the valve cylinder resulting in poor A/C performance. Valves that have been installed backwards should be replaced as damage to the seals can occur if the coolant flow has been applied in the wrong direction.

CAUTION

Removal of the coolant valve should be performed when the engine is cold. Attempting to remove the valve from the system when the engine is hot could result in burns and/or serious injury due to extremely hot coolant escaping under pressure. Do not start the engine while the coolant lines are disconnected as the engine will quickly pump the system dry, which could result in damage to the engine.

4. Verify that the heater supply hose (containing the coolant valve) is actually the hose coming from the supply port on the engine. The supply port is usually on, or near the engine thermostat housing. To positively identify the supply line, remove the valve from the coolant lines and place both ends of the lines into a container to capture escaping fluid. Have an assistant "turn over" the engine while you observe the coolant lines. ***The line that discharges coolant when the engine is turned over is the supply line for the HVAC system.***

NOTE: Note this procedure will not be useful for systems with a bypass or "H" fitting. Correct plumbing will have to be checked at "H" fitting in this case. See your vehicle chassis manual for systems with "H" bypass fittings in the coolant lines.

ELECTRICAL TESTING

1. Verify positive electrical connections at the coolant valve. Verify that a new valve has not been installed on an older system without a jumper harness.
 - A. If a new valve has been installed on an older system a jumper harness is required between the main harness and valve.
 - B. If a new valve is installed on newer system, a jumper harness **should not** be used between the valve and main harness.

NOTE: SEE SECTION 1, VALVE IDENTIFICATION FOR MORE INFORMATION REGARDING NEW AND OLD STYLE VALVES.

2. Unplug the wire harness connector from the coolant valve connector. Check the socket terminals for damage. Inspect the pin terminals on the coolant valve connector for damage. If any pins in the valve connector are loose or broken, replace the valve. Refer to the Electrical System Schematics for correct pin locations and wire colors.

*Note: Some early production Seitz valve actuators have a short four wire lead. Check the leads to insure they match the pin locations on the wire harness connector. The blue wire on the valve lead is for the manufacturer's testing purposes and is not used during normal valve operation. **When replacing this valve, order Evans kit # RV218999.***

TEMPERATURE CONTROL POTENTIOMETER

3. Use a DC voltage test meter and find a good vehicle ground for the negative probe. Do not use the negative connection on the wire harness.
4. Insert the positive probe from the meter into the black wire terminal on the wire harness valve connector. The voltage value should always read 0 VDC because this is the ground connection for the hot water valve.

NOTE: If voltage is detected on this circuit the entire harness should be visually inspected for damage, incomplete or misaligned connections. Do not proceed with testing until this voltage bleed has been resolved.

5. Insert the positive probe from the meter into the red wire terminal of the wire harness valve connector. The voltage value should always read near the vehicle's regulated voltage. If not then you have an issue with the wire harness or fuse.

NOTE: Low system voltage could be the result of numerous causes and will cause the valve to fail to operate. Do not proceed with testing until this voltage issue has been resolved.

6. Insert the positive probe from the meter into the yellow wire terminal of the wire harness valve connector. Rotate the temperature control knob to the far left (BLUE) position. The voltage value should always read near the vehicle's regulated voltage when the potentiometer is in the closed (BLUE) position.
7. Rotate the temperature control knob to the far right and measure the yellow wire connection. The voltage value should always read 0 VDC when the potentiometer is in the open (RED) position.
8. If the proper voltage readings are not measured at either valve position and all other electrical issues have been resolved, then replace the temperature control potentiometer (**Evans replacement part # RV218549**).

ELECTRONIC VALVE

9. If the voltages readings at the valve connector are normal then carefully plug the connector into the valve and then remove the HVAC control panel to access the temperature control potentiometer connector.
10. Remove the connector from the potentiometer and install a jumper wire on the connector from the red wire terminal to the yellow wire terminal. This will apply full vehicle voltage to the valve and force the valve to fully close. Look into the valve coolant inlet to visually verify that the valve is completely closed.
- 11/ Change the jumper from the red wire terminal to the black wire terminal so that the jumper connects the yellow wire terminal to the black wire terminal. This will ground the control wire of the actuator and the valve should be completely open. Visually verify again.

NOTE: By nature of the design of the valve, when the coolant valve gate is fully open, half of the valve port opening appears to be blocked. At no time will the valve port appear to be empty

12. If the valve does not visually open or close completely then replace it, attach the coolant inlet hose and secure assembly for proper operation.
13. Proceed to SYSTEM VERIFICATION TEST to determine if repair is complete. Keep in mind that if heated coolant has traveled through the heater core prior to these tests then it will take several minutes before the core cools and proper valve operation can be verified. Operating the A/C system for a few minutes will speed up the process of cooling the heater core.

SYSTEM VERIFICATION TEST

1. Attach both coolant hoses to the correct valve ports, reinstall the control panel, and secure the vehicle for operation.
2. Set the Mode Switch (right side of control panel) to "Vent".
3. Rotate the temperature control to full cool (BLUE - far left position).
4. Start the engine and set the engine speed to 1500 rpms if possible. Remember to have the vehicle transmission in neutral gear and the parking brake ON.
5. Measure the Fresh Air inlet temperature and the dash vent air temperature nearest to the unit (passenger side dash louver) and record the values. Repeat these measurements at 5 minute increments until the engine has reached normal operating temperatures.
6. If the inlet and outlet temperature difference does not vary significantly as the engine warms the coolant then the valve can be considered completely closed. If the temperature difference increases significantly then the valve is leaking coolant through the heater core; replace the valve assembly.
7. Rotate the temperature control to full heat; an immediate significant temperature change should occur between the inlet and outlet temperature readings.
8. Rotate the temperature control back to full cool and monitor the temperature differential. The change will be slower, but the outlet temperature should drop to where no significant difference is detected between inlet and outlet temperatures. If the temperature difference does not stabilize then the valve is leaking coolant through the heater core; replace the valve assembly.

9. Once the faulty component has been identified, the new replacement permanently installed, and everything is buttoned back up, perform an actual function test for warm and cool air with the vehicle running. Test A/C performance using the [A/C Systems Operational Check](#) and [Estimated A/C Performance Guidelines](#).

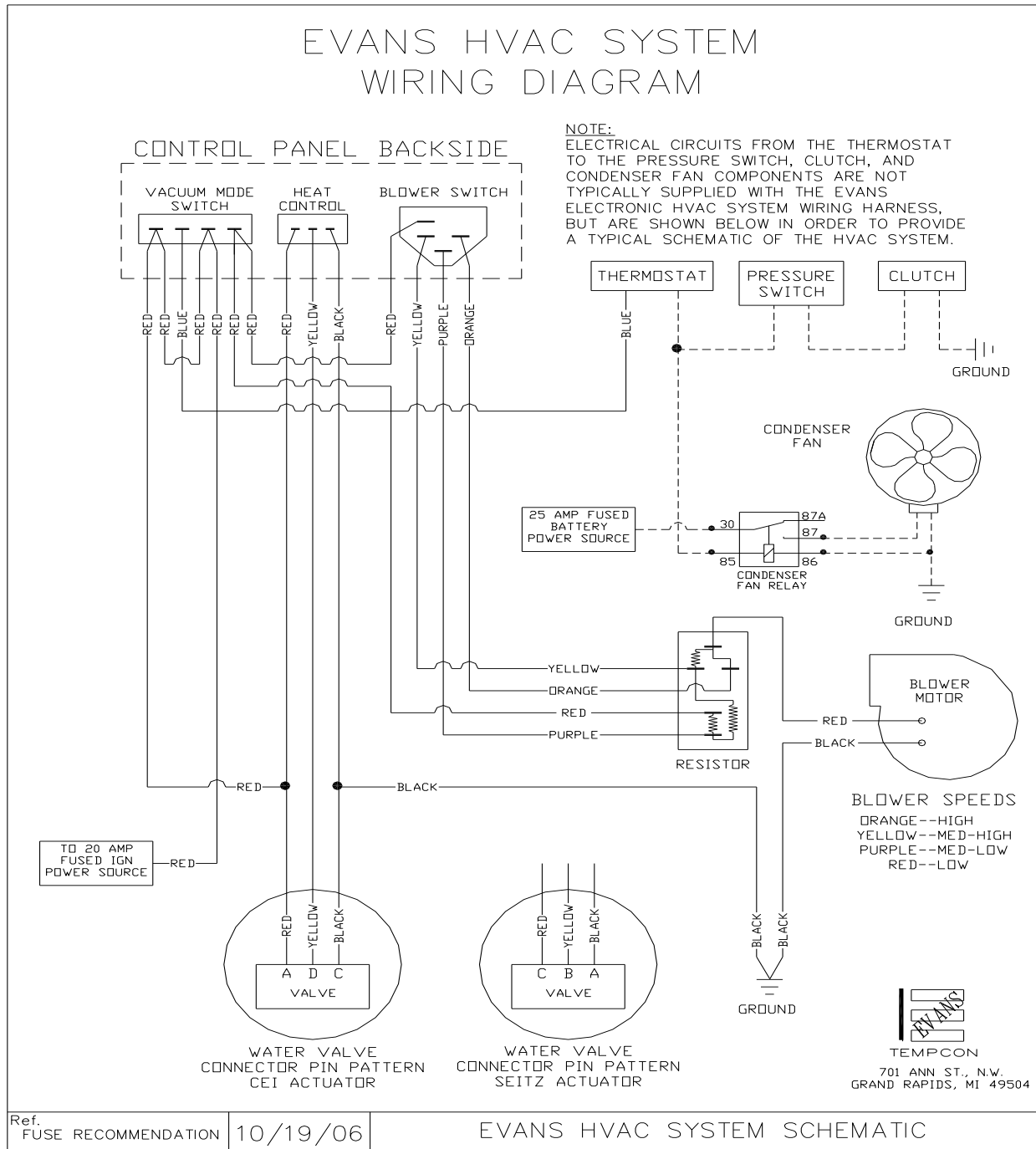

ELECTRICAL TROUBLE SHOOTING FOR EVANS TEMPCON HEATER A/C SYSTEMS

<u>PROBLEM</u>	<u>POSSIBLE CAUSES</u>	<u>REMEDY</u>
1. A/C Clutch does not operate Blower operates as it should.	*Faulty Rotary Mode Selector Switch	*Check for switch continuity. Replace if necessary.
	*Clutch Circuit Wires have fallen off of Clutch Terminal, Thermostat or Pressure Switch.	*Re-install clutch circuit wires as required.
	*Faulty A/C Thermostat	*Jumper across thermostat terminals. If clutch engages, replace thermostat.
	*Faulty A/C Pressure Switch (make certain adequate refrigerant is contained in system)	*Ensure switch is tight on fitting. *Jumper across switch terminals (A/C Thermo. and "comp" terminals for trinary switch). If clutch engages, replace switch.
	*Faulty A/C Clutch	*With engine OFF apply 12V+ supply directly to clutch terminals and listen for clutch engagement. Replace clutch if engagement. Replace clutch if there is no engagement.
2. HVAC Accessory Fuse Blows when Rotary Mode Selector switch is in any position except "OFF", "Vent", and "Floor".	*Faulty Chassis Circuitry	*Referring to accompanying wiring, (Chevrolet & Ford) diagram, if voltage is read at point "A" when A/C switch is depressed and clutch engages when 12V+ power is applied directly to clutch terminal, problem is originating in chassis wiring. Refer to chassis manufacturer's service manual.
	*Short Circuit in Clutch Circuit Wiring	*Inspect all associated wiring (blue wire from control panel to thermostat, wiring from thermostat to pressure switch and from pressure switch to clutch).

NOTE: FOLLOW DIAGNOSIS PROCEDURE IN "REMEDY" COLUMN IN THE ORDER LISTED.

ELECTRICAL TROUBLE SHOOTING (Cont'd)

<u>PROBLEM</u>	<u>POSSIBLE CAUSES</u>	<u>REMEDY</u>
2. Cont'd	* Short Circuit in Clutch	* With engine OFF apply an 8 amp fused 12V+ power supply directly to Clutch terminals. If fuse blows, replace Clutch.
3. Blower Does Not Operate at any speed.	* A/C Circuit Fuse is Blown	* Replace with 25 Amp Fuse and test system for proper operation.
	* Power Lead to Control Panel has fallen off at the power source (fuse block).	* Re-install Power Lead to Coach Manufacturer's specified terminal at fuse block.
	* Ground Wire for Control Panel has fallen off or has come loose from the chassis ground location.	* Check that ring terminal on black wire of harness is adequately fastened to a good chassis ground.
	* Wire Harness connector(s) at resistor or motor has fallen off.	* Re-install Connector(s) and check blower for proper operation
	* Open Circuit in Wire Harness Between Resistor and Blower Motor or from Power Source to Control Panel or from Panel to Resistor.	* Inspect wiring from Resistor to motor, from power source to control panel and from control panel to resistor. Repair broken wires as required.
	* Faulty Control Panel	* With vehicle ignition switch in the ON position, rotate mode selector switch to any position except OFF and rotate blower switch to the HIGH speed setting. Using a voltmeter, check for voltage in the orange wire at the resistor. If no voltage is read, replace control panel.
	* Faulty Resistor	* With vehicle ignition switch in the ON position, rotate blower switch to high speed. Using a voltmeter, check for voltage at the resistor pin which feeds the red motor wire. If no voltage is read, replace resistor.

ELECTRICAL TROUBLE SHOOTING (Cont'd)

<u>PROBLEM</u>	<u>POSSIBLE CAUSES</u>	<u>REMEDY</u>
3. Cont'd	* Faulty Blower Motor	* With vehicle ignition switch in the ON position, rotate Blower Switch to High Speed. Using a voltmeter, check for voltage at the Red Motor connector wire. If voltage is read, replace Blower Motor.
4. Blower does not operate	* Improperly installed Wire connectors	* Inspect connectors at each end of at all speeds. Connectors end of the wire harness. Ensure that all socket terminals on the ends of the leads are fully inserted and locked into the connector. Push the connectors fully into the Control Panel, and the Resistor Terminals. Check Blower for normal operation.
	* Faulty Control Panel	* With the vehicle ignition switch in the ON position, rotate Blower Switch to a speed that isn't working using the accompanying wiring diagram, locate the corresponding terminal on the back of the control for the fan switch speed position selected. Measure the voltage at this terminal. If no voltage is read, replace Blower Switch.
	* Open Circuit in Wire Harness	* Remove the 4 wire connector of wire harness from the resistor. Re-install wire harness connections at the Control Panel. With the vehicle ignition switch in ON position rotate the Blower Switch to a speed that isn't working. Using the accompanying wiring diagram, identify the corresponding wire color for the fan speed position selected. Measure the voltage at the termination of the wire in the four socket connector. If no voltage is read, inspect the wire for damage and repair as required.

ELECTRICAL TROUBLE SHOOTING (Cont'd)

<u>PROBLEM</u>	<u>POSSIBLE CAUSES</u>	<u>REMEDY</u>
4. Cont'd	* Open Circuit in Resistor	* Re-install the 4 wire connector of the wire harness back onto the Resistor. With the vehicle ignition switch in the ON position, rotate the Blower Switch to a speed that isn't working. Measure the voltage at the pin on the connector of the wire harness that plugs into the motor connector. If no voltage is read, replace Resistor.
5. HVAC Circuit fuse blows when blower is turned on to any speed	* Damaged wiring between Resistor and Motor, or between Resistor and Control Panel. Possible damaged red power lead wire between control panel and fused power source.	* Inspect all associated wiring for insulation chafing or other damage that would result in shorting the circuit. Repair as required.
	* Short Circuit at Resistor	* Remove resistor from Air Box and inspect the Resistor windings for evidence of electrical arcing. Re-install Resistor ensuring that none of the windings or metal contacts are touching any portion of the Air Box itself.
	* Blower Wheel Rubbing on Blower Housing	* Inspect Blower Wheel to housing clearance
	* Faulty Blower Motor	* With the engine Off apply 25 amp fused, 12V+ power supply directly the terminals on the motor. If fuse blows, replace the motor.
6. HVAC Circuit Fuse Blows when Blower is switched to a particular speed.	* Damaged Wiring between Control Panel and Resistor	* Make note at what speed the fuse blows. Using the accompanying wiring diagram, identify the corresponding wire color for the fan switch speed position on which the fuse blew. Inspect this wire for any chafing or other damage that would result in shorting the circuit. Repair as required.

TYPICAL PUSHER CHASSIS CLUTCH AND CONDENSER FAN CIRCUIT

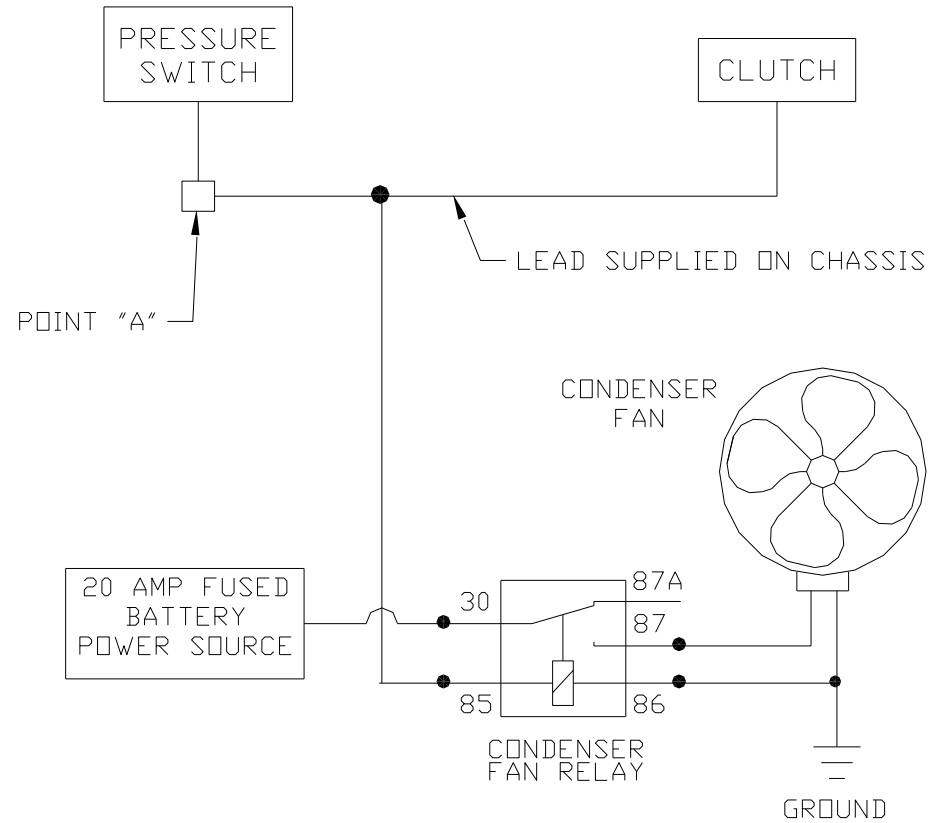

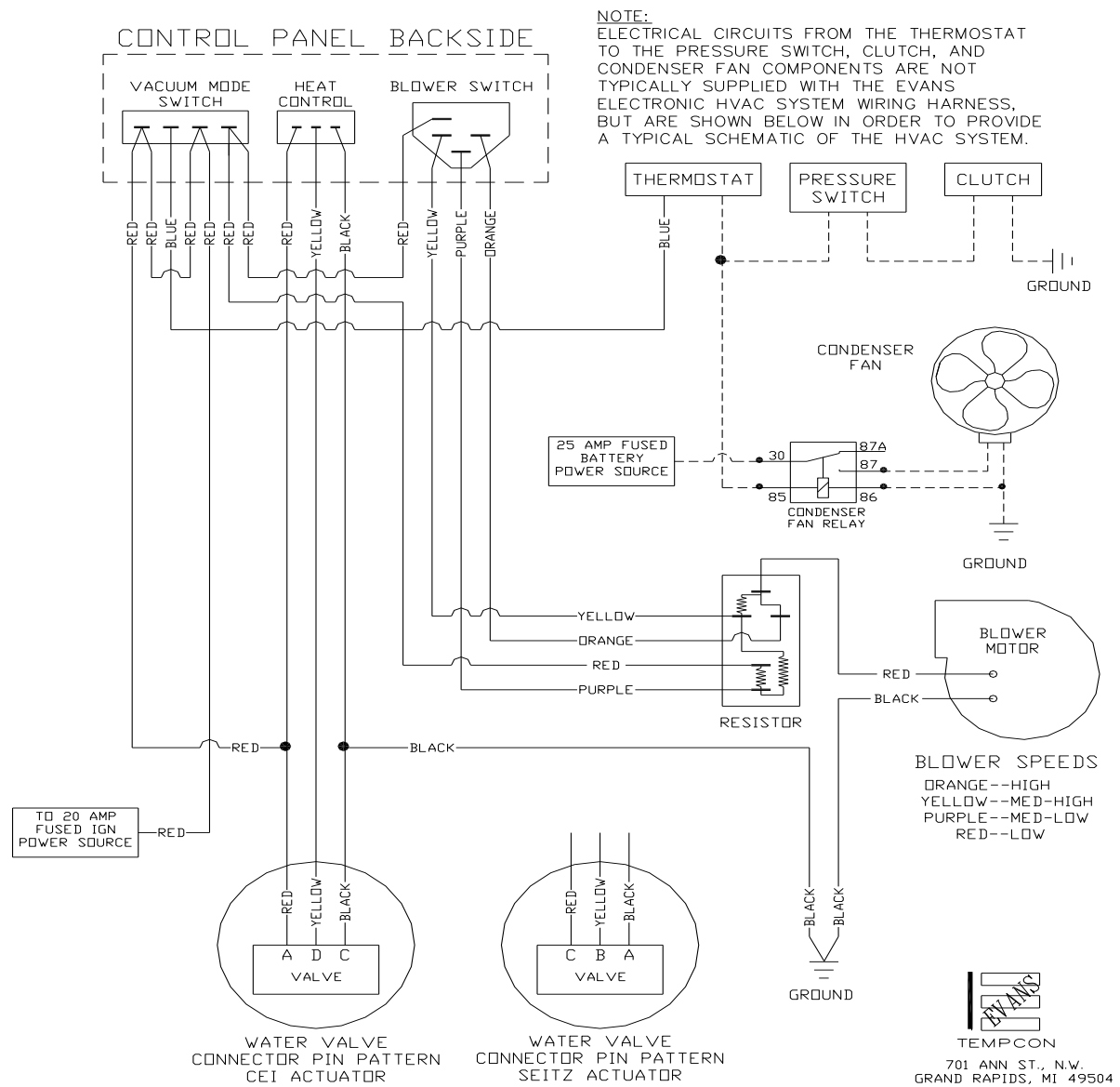

 TEMP CON
 701 ANN ST., N.W.
 GRAND RAPIDS, MI 49504

EVANS HVAC SYSTEM WIRING DIAGRAM

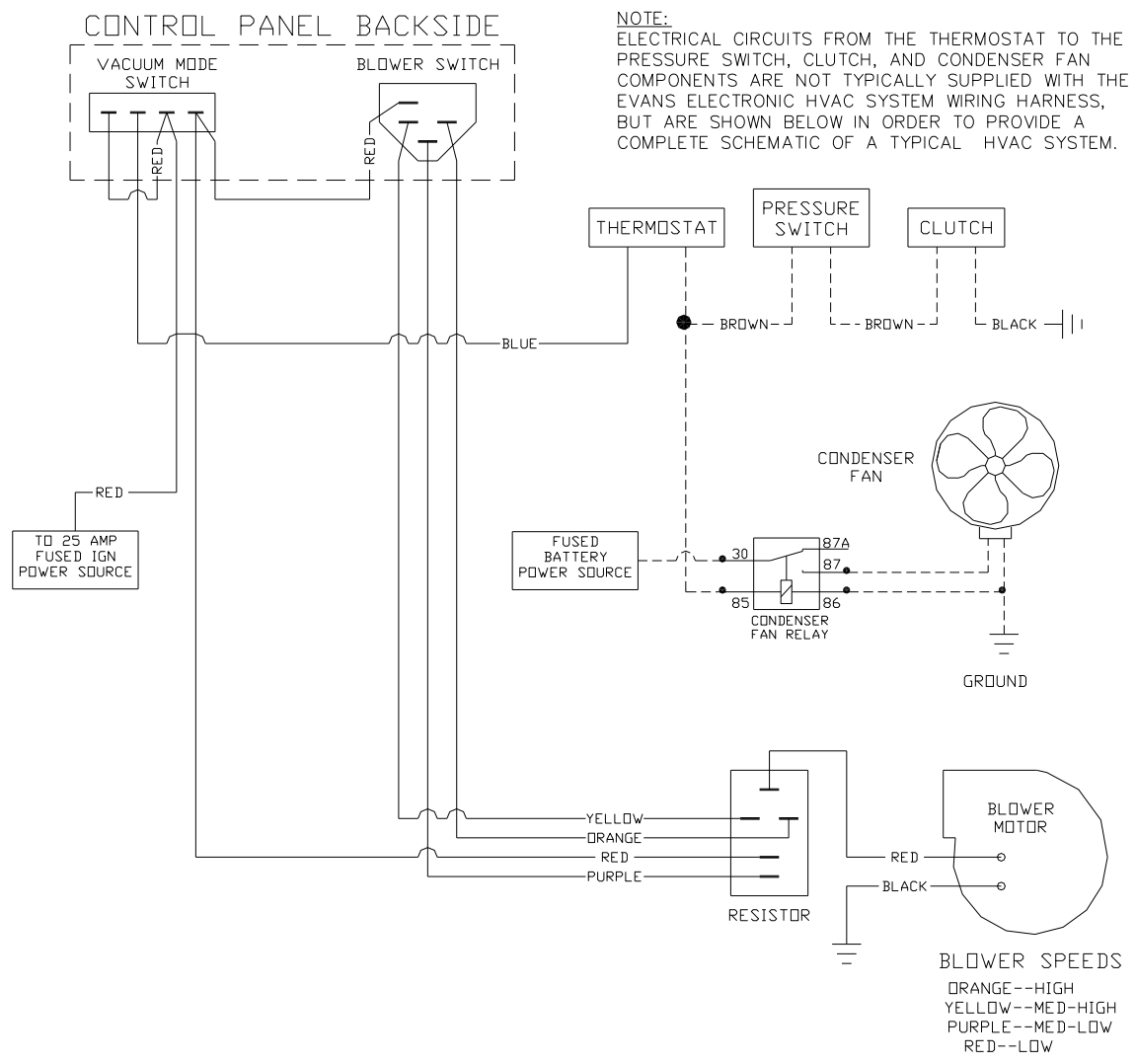

TYPICAL ROTARY CABLE CONTROL PANEL GENERAL SCHEMATIC FOR MOST CHASSIS



NOTE:
 ELECTRICAL CIRCUITS FROM THE THERMOSTAT TO THE PRESSURE SWITCH, CLUTCH, AND CONDENSER FAN COMPONENTS ARE NOT TYPICALLY SUPPLIED WITH THE EVANS ELECTRONIC HVAC SYSTEM WIRING HARNESS, BUT ARE SHOWN BELOW IN ORDER TO PROVIDE A COMPLETE SCHEMATIC OF A TYPICAL HVAC SYSTEM.

EVANS
 TEMPCON
 701 ANN ST., N.W.
 GRAND RAPIDS, MI 49504

VACUUM TROUBLE SHOOTING GUIDE FOR EVANS TEMPCON HEATER A/C SYSTEMS

<u>PROBLEM</u>	<u>POSSIBLE CAUSES</u>	<u>REMEDY</u>
1. Air Flow Comes from Defrost Louvers regardless of mode selected	*Vacuum supply line to control panel has fallen off of vacuum reservoir.	*Ensure that black line of vacuum harness is pushed fully onto the corresponding port of the vacuum reservoir.
	*Manifold vacuum supply hose has fallen off at vacuum reservoir or at manifold port.	*Ensure that both ends of the supply hose are firmly attached to their corresponding ports.
	*Severe leakage in vacuum supply circuit.	*Examine vacuum supply hose from manifold to vacuum ball and black supply lead of vacuum harness from vacuum ball to control panel for cuts or pinching. Repair or replace as required.
	*Faulty control panel or vacuum harness.	*Having checked above causes and finding no problem: check for vacuum at the white, yellow, red, green, and blue vacuum leads of the harness while changing through all operational modes. If no vacuum is detected, replace vacuum mode switch and/or harness.
	*Pinched Vacuum Lines	*Inspect red, green, white, and yellow vacuum lines for pinching or kinking. Repair/replace as required.
2. Air Flow is suddenly and momentarily diverted to defrost louvers while driving.	*Leak in Vacuum Reservoir, vacuum hose from manifold or vacuum reservoir. Check valve. Inadequate vacuum supply.	*Measure vacuum at the small port on the reservoir with the engine running at idle. Turn the engine off and take note of the time for vacuum loss to 10 in. of hg. If this time is shorter than 5 sec., inspect hose and reservoir for leaks. Repair / replace as required.

NOTE: FOLLOW DIAGNOSIS PROCEDURE IN “REMEDY” COLUMN IN THE ORDER LISTED

VACUUM TROUBLE SHOOTING GUIDE (Cont'd)

PROBLEM	POSSIBLE CAUSES	REMEDY
3. Air Flow comes from Face Louvers regardless of mode	<ul style="list-style-type: none">* Face Door of Air Box is Binding* Door/Vacuum Motor Linkage has come apart* Door/Vacuum Motor Linkage is binding.* Faulty Control Panel	<ul style="list-style-type: none">* Inspect door for adequate clearance with top and bottom of air box, or any loose foam seals. Repair/replace as required.* Re-assemble linkage. Check for proper operation* Inspect linkage for bind points. If necessary increase Clearances with small file. Check for proper operation.* With engine running, select Floor, mix or defrost mode On the control panel. Remove the yellow and white Vacuum Leads from the Vacuum Motor. If face door Closes and vacuum is present at the Green and White leads, replace Control Panel Mode Switch.
4. Fresh Air/Recirc. Air Door does not operate. Air Flow modes operate correctly.	<ul style="list-style-type: none">* Recirc. & Fresh Air Door(s) Binding.* Pinched Vacuum Line* Door/Vacuum Motor Linkage has come apart.* Door/Vacuum Motor Linkage is Binding.	<ul style="list-style-type: none">* Inspect Door(s) for interference points with evaporator Case, or any loose foam seals. Repair/replace as Required.* Inspect Blue Vacuum Line(s) for pinching or kinking. Repair/replace as required.* Re-assemble linkage. Check for proper operations.* Inspect Linkage for bind points. If necessary, increase Clearances with a small file. Check for proper Operation.

VACUUM TROUBLE SHOOTING GUIDE (Cont'd)

PROBLEM	POSSIBLE CAUSES	REMEDY
4. Cont'd	* Faulty Control Panel	* With engine running, position the rotary Mode Selector to the "MAX A/C" setting. If vacuum is not present at the Blue Lead, replace the Rotary Mode Switch.
	* Faulty Vacuum Motor	* With engine running, position the Rotary Mode Selector to the "MAX A/C" setting. If vacuum is present at the Blue Lead, replace Vacuum Motor.
5. Inability to change air flow to Defrost mode. Floor and Face mode operate correctly.	* Defrost Door of Air Box is binding.	* Inspect door for adequate clearance with top and bottom of Air box or any loose foam seals. Repair/replace as Required.
	* Door/Vacuum Motor Linkage is binding.	* Inspect linkage for bind points. If necessary, increase Clearance with a small file. Check for proper operation.
	* Faulty Control Panel	* With engine running, select Defrost mode on the Control Panel. Remove the Red and Green Vacuum Leads from Vacuum Motor. If door closes on the floor collars of the air box and there is vacuum present at the Red and Green Leads, Replace Mode switch.
6. Inability to change air flow to Floor mode. Defrost and Face Mode operate correctly.	* Defrost/Floor Door binding.	* Inspect Door for adequate clearance with top and bottom of air box or for any loose foam seals. Repair/replace as Required.
	* Pinched Vacuum Line(s)	* Inspect Red and Green Vacuum Leads for pinching or kinking. Repair/Replace as required.

VACUUM TROUBLE SHOOTING GUIDE (Cont'd)

<u>PROBLEM</u>	<u>POSSIBLE CAUSES</u>	<u>REMEDY</u>
6. Cont'd	* Door/Vacuum Motor Linkage has come apart.	* Re-assemble linkage. Check for proper operation.
	* Door/Vacuum Motor Linkage	* Inspect linkage for bind points is binding. If necessary, increase clearances with a small file. Check for proper Operation.
	* Faulty Control Panel	* With engine running, select the Floor mode, If vacuum is Not present at the Red and Green Leads, replace Mode Switch.
	* Faculty Vacuum Motor	* With the engine running, select the floor mode. If vacuum is present at the Red and Green Leads, replace Vacuum Motor.
7. Inability to obtain air flow from Face Louvers. Defrost and Floor Modes Operate	* Face Door is Binding	* Inspect Door for adequate clearance with top and bottom of air box or for any loose foam seals. Repair/replace as required.
	* Pinched Vacuum Line(s)	* Inspect Yellow and White Vacuum lines for pinching or kinking. Repair/replace as required.
	* Door/Vacuum Motor Linkage has come apart.	* Re-assemble linkage. Check for proper operation.
	* Door/Vacuum Motor Linkage is binding.	* Inspect linkage for bind points. If necessary, increase Clearance with a small file. Check for proper operation.
	* Faulty Control Panel	* With engine running, select "MAX A/C" or "A/C" Mode. If vacuum is not present at Yellow & White Vacuum Lines, replace Mode Switch.

VACUUM TROUBLE SHOOTING GUIDE (Cont'd)

PROBLEM	POSSIBLE CAUSES	REMEDY
7. Cont'd	<ul style="list-style-type: none">* Faulty Vacuum Motor and White Vacuum* Yellow and White Vacuum Leads reversed on Bi-Level Vacuum Motor.	<ul style="list-style-type: none">* With the engine running, select "MAX A/C" or "A/C" mode. If vacuum is present at the Yellow Lines, replace Vacuum Motor.* Switch Leads.
8. Inability to obtain Bi-Level Air flow. Other modes operate Correctly.	<ul style="list-style-type: none">* Refer to "Possible Causes" list for Problem #7.	<ul style="list-style-type: none">* Refer to "Remedy" list for Problem #7. High probability Of reversed yellow and white vacuum leads on bi-level Motor.
9. Inability to obtain mix (Floor/ Defrost) air flow. Other modes operate correctly.	<ul style="list-style-type: none">* Refer to "Possible Causes" list for Problem #5 and #6.	<ul style="list-style-type: none">* Refer to "Remedy" list for Problem #5 and #6. High Probability of reversed red and dark green vacuum leads On mix motor.

STANDARD HVAC SYSTEM VACUUM LOGIC

ROTARY SELECTOR VACUUM LOGIC

MODE SWITCH	Circuit #:	1	2	3	4	5	6
	Line Color:	BLUE	GREEN	BLACK	YELLOW	RED	WHITE
MAX A/C		●		■	●		●
A/C				■	●		●
VENT				■			●
OFF		●	●	■		●	
BI-LEVEL				■		●	●
FLOOR			●	■		●	
MIX (FLR/DEF)				■		●	
DEFROST				■			



INDICATES VACUUM SIGNAL



BLACK LINE IS VACUUM SOURCE

VACUUM HARNESS DIAGRAM

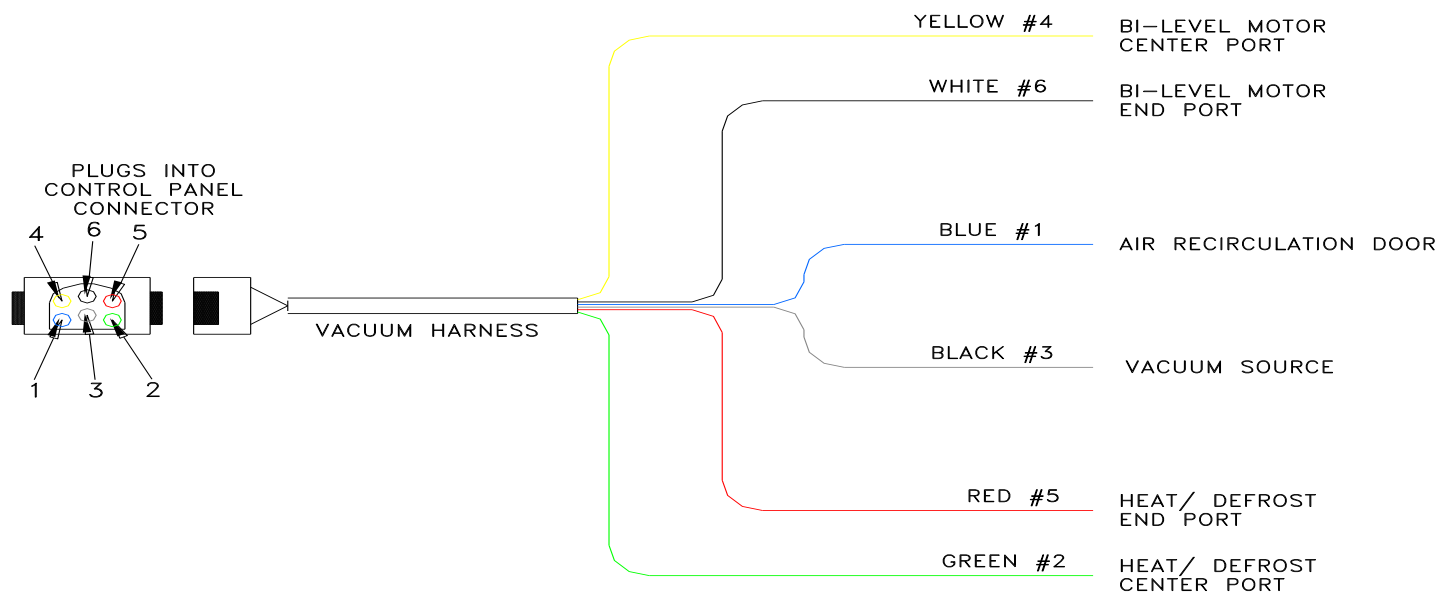

AIR CONDITIONING TROUBLE SHOOTING GUIDE FOR EVANS TEMPCON HEATER – A/C SYSTEMS

PROBLEM

1. Inadequate cooling
(discharge air from A/C
vents is only slightly cool.

POSSIBLE CAUSES

*Misadjusted or leaking valve
(cooling may be diminished at
Engine idle. Increased engine and
compressor speed will improve A/C
cooling).

For electronic valves see:

ELECTRONIC COOLANT VALVE OR EVANS NEW ELECTRONIC VALVE

*Condenser clogged with road
debris or condenser fan inoperative.

*Incorrect refrigerant charge in
system. If charge is excessively low
or high, the compressor clutch will
not engage, or remain engaged.

*Moisture or air present in system.

REMEDY

***Cable Operated Valve**

Clamp off the heater hose containing the coolant valve and retest the air conditioner. If the performance improves, the valve may be incorrectly adjusted or leaking. Assure that the coolant flow through the valve is in the same direction as the flow arrow printed or molded onto the valve itself. Re-adjust cable so that the valve is in the **FULL CLOSED** position when the control panel temperature knob is in the **FULL COOL** position. Replace the valve if no improvement is observed.

*Examine fin region of the condenser for debris and bent fins. Clean and Straighten as required. Repair and/or replace the condenser fan components as required.

*Install manifold gauge set onto high side and low side service ports and operate A/C. Observe for low pressures. If low pressures are observed, leak check all A/C components as required. If excessive loss is suspected, check oil level in compressor, evacuate and recharge.

*Discharge and recover refrigerant. Replace receiver-drier. Add 2 ounces of oil (to replace old oil removed with the old receiver-drier), evacuate and recharge.

NOTE: FOLLOW DIAGNOSIS PRECEDURE IN “REMEDY” COLUMN IN THE ORDER LISTED

AIR CONDITIONING TROUBLE SHOOTING GUIDE FOR EVANS TEMPCON HEATER – A/C SYSTEMS

<u>PROBLEM</u>	<u>POSSIBLE CAUSES</u>	<u>REMEDY</u>
1. Con't.	*Restriction in receiver-drier or liquid line resulting in a starved evaporator.	*If low and high side readings are excessively low and/or the liquid line at the expansion valve is cool to the touch and showing signs of sweating or frosting, discharge and recover the refrigerant. Replace the receiver-drier, liquid lines or any other defective parts. Add 2 ounces of oil (to replace oil removed with the old receiver-drier), evacuate and recharge.
	*Defective expansion valve restricting flow.	*Symptoms are the same as receiver-drier restriction. Discharge and recover refrigerant. Remove and replace expansion valve. Check oil level in the compressor, evacuate and recharge.
	*Defective, worn or leaking compressor.	*Low side gauge reading too high and high side gauge reading too low. Discharge and recover refrigerant. Remove and replace new or rebuilt compressor and replace receiver-drier. Add 2 ounces of oil (to replace oil removed with the old receiver-drier), evacuate and recharge.
2. Inadequate cooling during hot part of the day.	*Excessive moisture in system freezing in expansion valve and restricting refrigerant flow.	*Discharge and recover refrigerant. Replace receiver-drier, check oil level in compressor, evacuate and recharge. .
3. Gradual loss over time of cooling and air flow during A/C operation.	*Defective thermostat, causing continuous operation of the compressor thereby freezing condensation within the evaporator core.	*Examine capillary tube of thermostat to ensure that it is inserted into the evaporator fins. If the core still freezes and the compressor clutch doesn't cycle off, replace the thermostat.
4. Compressor clutch cycles too rapidly or discharge air warms excessively during compressor clutch "OFF" cycle.	*Defective thermostat	*Replace thermostat

NOTE: FOLLOW DIAGNOSIS PROCEDURE IN "REMEDY" COLUMN IN THE ORDER LISTED

HEATER TROUBLESHOOTING GUIDE **FOR EVANS TEMPCON HEATER—A/C SYSTEMS**

PROBLEM	POSSIBLE CAUSES	REMEDY
1. Inadequate or no heat (discharge air only slightly warm or neutral)	<p>*Engine cooling system is low on coolant</p> <p>*Water valve stuck closed</p> <p>*For Electric valves see: ELECTRONIC COOLANT VALVE OR EVANS NEW ELECTRONIC VALVE</p> <p>*Excessive air leaks in coach body work and firewall under dash</p> <p>*Pinched heater hose or other system flow restriction</p> <p>*Engine running cold. Engine thermostat stuck open</p>	<p>*Check engine coolant level per chassis manufacturer's recommendation. Add coolants as required.</p> <p>*Cable operated valve: Examine coolant valve cable under the hood and at the control panel behind the dash to ensure that the actuator cable is correctly installed at both locations. Operate the valve by rotating the temperature control knob on the control panel back and forth and observe crank rotation at the valve. With the engine running at normal operating temperature, position control panel knob to full heat. Hoses on both sides of valve should be hot to the touch. If not, replace coolant valve</p> <p>*Locate and seal leaks as required</p> <p>*Examine heater hoses from engine cooling system to the heater core for pinches and kinks. Repair or replace as required. Visually examine heater core for dented tubes. Check the core for free flow by circulating an outside water source through it. Replace heater core if a restriction is observed</p> <p>*Check engine coolant temperature specifications according to chassis manufacturer's recommendations. Repair if required.</p>

DEFROSTER TROUBLE SHOOTING GUIDE FOR EVANS TEMPCON HEATER - A/C SYSTEMS

<u>PROBLEM</u>	<u>POSSIBLE CAUSES</u>	<u>REMEDY</u>
1. Little or No Air Flow from Defrost Vents while in Defrost Mode.	<ul style="list-style-type: none">* Air Leaks between system componentry. * Air Distribution Box not operating properly.	<ul style="list-style-type: none">* Examine Air Distribution Box attached to the firewall Beneath the dashboard. Ensure that it is tightly anchored To the firewall and that no air leaks can be felt while Operating the blower at high speed. Examine the defrost Plate, Duct Hoses and Defrost Plenums where applicable in the same fashion. Repair/replace as required. * Refer to Vacuum Trouble shooting guide for diagnosis And recommended repair.

COOLANT IN-LINE FILTER KIT INSTALLATION AND SERVICING INSTRUCTIONS

1. INSTALLATION:

Determine which hose attached to the valve is the supply hose from the engine. The supply hose is connected to the valve on the opposite side of the valve from the wire harness connector (see illustration below).

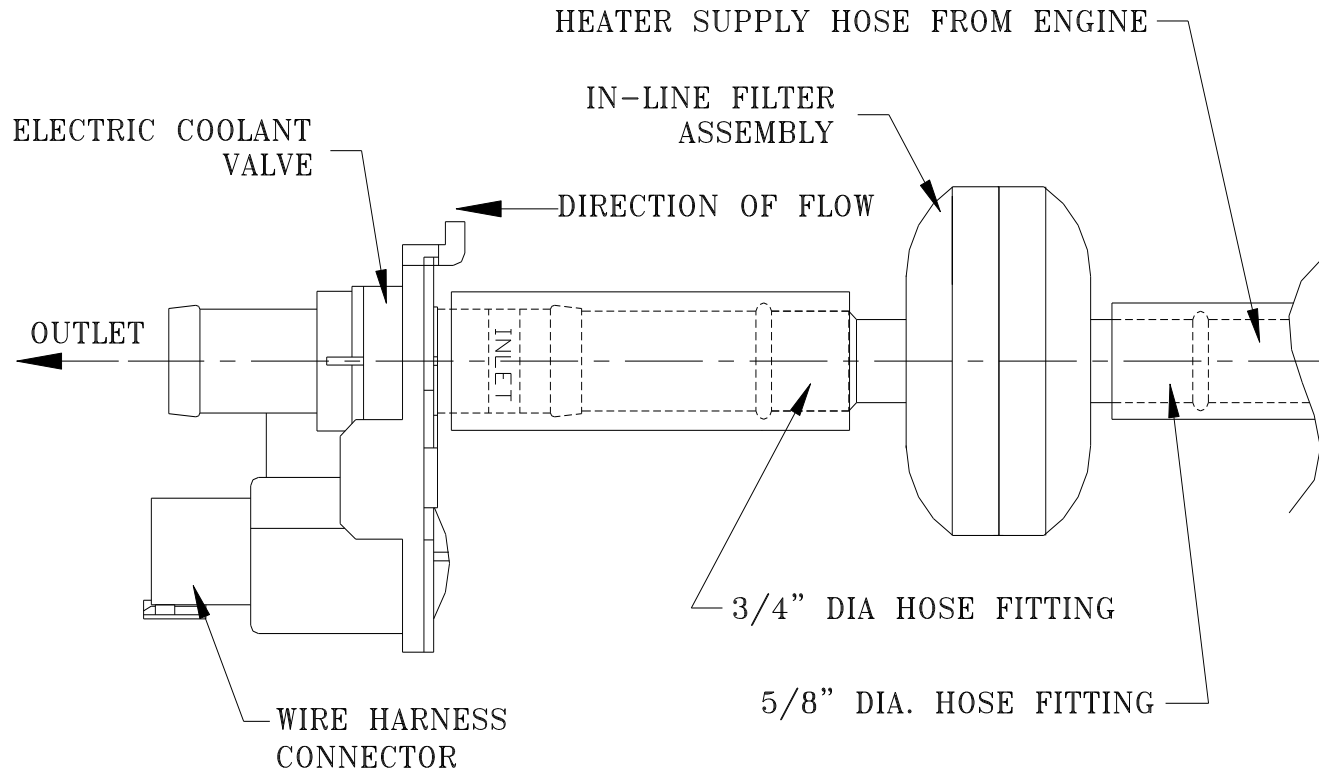

CLAMPS NOT SHOWN ON COMPONENTS FOR CLARITY

Place a clamping device on the inlet side of the reducer fitting that connects the 5/8" supply hose to the 3/4" hose on the inlet side of the valve (clamp on 5/8" hose). Place a second clamping device between the coolant valve and base unit (clamp 3/4" hose on outlet side of valve). Remove the reducer fitting, capturing the coolant in a pan. Remove the short section of 3/4" hose attached to the inlet side of the valve.

CAUTION: The engine should be cold and the vehicle turned off before attempting to remove the reducer fitting. Opening coolant lines on systems that are hot can result in burns and/or serious injury due to extremely hot coolant escaping under pressure.

Install the 4" section of 3/4" hose (supplied) on the inlet side of the valve. The In-Line Filter Assembly is supplied with a 5/8" hose fitting on the inlet side of the assembly and a 3/4" hose fitting on the outlet side. Place two (2) clamps over the new section of 3/4" hose and insert the In-Line

Filter Assembly into the coolant line with the 3/4" fitting into the 3/4" hose (the large fitting on the filter should be closest to the valve) as shown above. Place one (1) clamp over the end of the 5/8" supply line hose, then connect it to the 5/8" fitting on the filter assembly. Tighten the clamps on the valve and the In-Line Filter Assembly (clamps are not shown in the drawing).

The filter assembly and coolant valve should be supported in the heater compartment and not allowed to "float" on the coolant lines. Tie-wraps or strap type of clamps can be placed around the body of the filter assembly and attached to the fire wall to support the filter. The coolant valve has mounting holes in it that allow it to be bolted to a bracket or clamped in place.

NOTE: THE VALVE AND FILTER ASSEMBLY MUST BE INSTALLED IN A HORIZONTAL PLANE AS SHOWN IN THE DRAWING.

2. FILTER SERVICING:

CAUTION: The engine should be cold and the vehicle turned off before attempting to remove and service the filter assembly. Opening coolant lines on systems that are hot can result in burns and/or serious injury due to extremely hot coolant escaping under pressure.

Should the ability of your HVAC system to produce heat deteriorate, it may be necessary to check the In-line Filter for debris. This is done by placing a clamping device on both sides of the filter assembly to block the loss of coolant and then removing the filter assembly from the coolant lines. Be prepared to capture any coolant in a clean container.

The filter assembly can now be flushed to remove any debris by pouring water through the large (3/4") port and allowing it to drain out the Smaller (5/8") port. The water used to flush the filter should be captured and examined for debris. Before reinstalling the filter assembly, A small amount of coolant should be flushed out of the inlet line to clear it of any debris. Be sure all connections are secure and no leaks Are evident.

NOTE: Should an excessive amount of debris be evident in the filter, or if the filter is repeatedly blocked by debris, it is strongly Recommended that the entire coolant system be drained, flushed thoroughly, and refilled with new coolant, per the vehicle manufacturer's Specifications.