

**CR
FLEX**

**NEXGEN[®]
COMPLETE
KNEE
SOLUTION**

Surgical
Technique
for the
CR-Flex
Fixed Bearing
Knee



zimmer
Confidence in your hands™

Surgical Technique developed in conjunction with:

Kim C. Bertin, M.D.
Utah Hip and Knee Center
Suite 100
2490 South State Street
Salt Lake City, UT 84115

William R. Kennedy, M.D.
Kennedy-White Orthopedic Center
1818 Hawthorne Street
Sarasota, FL 34239

Carlos J. Lavernia, M.D.
1321 Northwest 14th Street
Suite 511
Miami, FL 33125

CONTENTS

INTRODUCTION	2
PREOPERATIVE CONDITIONING	4
PREOPERATIVE PLANNING	4
SURGICAL TECHNIQUE	4
Incision and Exposure	5
Femoral Preparation	6
Determine External Rotation	7
Tibial Preparation	8
Posterior Condyle Recut	9
Finish the Tibia	10
Prepare the Patella	11
Balance Soft Tissues	11
Varus Releases	11
Valgus Releases	12
Trial Reduction	13
Balance Flexion and Extension Gaps	14
Implantation	15
Closure	18
REHABILITATION PROTOCOL	18
APPENDIX: CROSSOVER TECHNIQUES	19





INTRODUCTION

The *NexGen* CR-Flex Fixed Bearing Knee is a cruciate retaining prosthesis designed to safely accommodate greater range of motion for cultural, recreational, or work activities that require deep flexion.

The development of the CR-Flex Fixed Bearing Knee is the result of an analysis of the normal knee prosthesis as it undergoes deep flexion beyond 120°. Multiple design features are incorporated to accommodate high flexion activities. For example, the interaction of the posterior condyles on the articular surface was carefully tested. As a result, efforts were made to optimize the contact area as the posterior condyles roll back to flexion angles of up to 155° (Fig. 1). This was addressed by thickening the posterior condyles, thereby extending the condylar radius in the sagittal plane.

Fig. 1

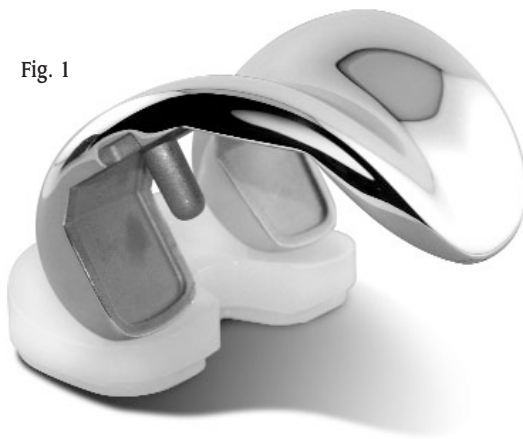

The posterior distal radius of the lateral condyle was extended slightly more than that of the medial condyle to further enhance natural anteroposterior rollback. Optimization of internal and external rotation at high-flexion range of motion was achieved by modifying the medial surface of the lateral condyle. The height of the posterolateral

condyle was decreased to reduce the tightness of the lateral retinacular ligament in high flexion.

The tibial articular surface was also considered in the design. In deep flexion, the extensor mechanism experiences a high level of stress as the soft tissues are stretched and pulled tightly against the anterior tibia and distal femur. A larger, deeper anterior cutout on the articular surface was designed to help avoid impingement. (Fig. 2).

This cutout accommodates the extensor mechanism in deep flexion.

Fig. 2



These features are designed to accommodate high-flexion activities. When combined with the proper surgical technique and rehabilitation regimen, this device provides increased capability for patients who have both the flexibility and desire to increase their flexion range. Some patient factors, however, may limit the potential for high flexion. The CR-Flex is not contraindicated for these patients. Even patients who do not have the potential for high flexion may benefit from the *NexGen* CR design features that are incorporated into the CR-Flex Knee.

PATIENT SELECTION

A common view among orthopaedic surgeons is that certain patients have greater potential for achieving higher flexion after knee replacement. Patients with good flexion preoperatively tend to get better motion post operatively. To optimize use of the high-flexion design elements of the CR-Flex Knee, the following criteria should be considered.

1. The patient should have a need and desire to perform deep-flexion activities. This need may be dictated by cultural or social customs where practices such as frequent kneeling for prayer, sitting “cross-legged,” and squatting are common. Also, activities specific to daily living, leisure and recreation, or job performance may require high-flexion capability.
2. The patient should be capable of reaching 110° of flexion preoperatively with a reasonable probability of achieving a range of 125° postoperatively.

3. The patient should have stable and functional collateral ligaments. In patients with severe deformity, consider the patient’s expectation for achieving high flexion.
4. It may also be important to consider the length of time the patient has not performed high-flexion activities.

Keep in mind that the CR-Flex Fixed Bearing Knee is designed to accommodate high flexion, and not create high flexion.





PREOPERATIVE CONDITIONING

To help prepare the patient for surgery, it is helpful for the patient to perform mobility exercises to prepare the muscles for the postoperative rehabilitation protocol.

PREOPERATIVE PLANNING

Use the template overlay (available through your Zimmer representative) to help determine the angle between the anatomic axis and the mechanical axis of the femur. This angle should be reproduced intraoperatively.

Use the various templates to approximate the appropriate component sizes. The final sizes must be determined intraoperatively; therefore, larger and smaller sizes should be available during surgery.

The CR-Flex Knee Components can be implanted using any of the *NexGen* Knee Instrument Systems. These include:

- *Multi-Reference*® 4-in-1 Femoral Instrumentation System inclusive of Mini and *MIS*™ instrumentation
- *MICRO-MILL*® Instrumentation System (Milling or 5-in-1 Saw Blade Options)
- Intramedullary Instrumentation System

If the *Multi-Reference* 4-in-1 Femoral Instrumentation System is used, the posterior referencing technique will help provide a consistent flexion gap. Regardless of the instrumentation system used, the flexion and extension gaps should be equalized to help ensure knee stability.

SURGICAL TECHNIQUE

Surgical technique is an important factor to consider when attempting to maximize range of motion in total knee arthroplasty (TKA). Close attention must be paid to balancing the flexion and extension gaps, removing posterior osteophytes, posterior capsule tension, reproducing the joint line, and accurate sizing of the femoral component.

Altering the joint line can cause patellofemoral issues and limit the degree of flexion. An elevated joint line, for example, can cause tibiofemoral tightness in flexion thus restricting flexion and causing excessive rollback. It is possible that the joint line may be moved proximally if a preoperative flexion contracture is corrected by distal femoral resection. Movement of the joint line can be minimized by performing a posterior capsular release to correct flexion contractures.

The femur, tibia, and patella are prepared independently, and can be cut in any sequence using the principle of measured resection (removing enough bone to allow replacement by the prosthesis).

INCISION AND EXPOSURE

The medial parapatellar approach is recommended for the CR-Flex Knee. With the patient in the supine position and the knee slightly flexed, make a straight midline incision. Begin the incision in the medial quadriceps tendon above the superior pole of the patella. Extend it distally to below the level of the tibial tubercle (Fig. 3). The subvastus technique can also be used for the high-flexion CR Knee.

Fig. 3

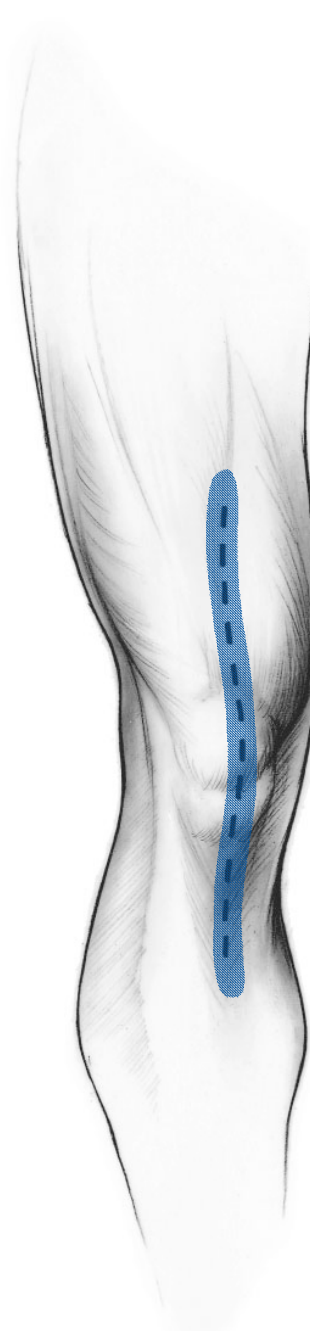



FEMORAL PREPARATION

Prepare the femur using the selected instrument system. Then proceed to "Posterior Condyle Recut" in this technique to remove the additional bone required for the CR-Flex Femoral Component.

When sizing the femoral component, it is preferable to select the closest size. However, depending on the situation, selecting the closest size could mean either upsizing or downsizing.

Using the selected instrumentation system, and following the appropriate technique for that system, prepare the femur. **If a size B femoral component is chosen, do not drill the distal femoral post holes at this time.** Size B femoral components have smaller pegs. The holes should be drilled using the size A/B Femoral Peg Drill and the Posterior Recut Guide.

Using a posterior referencing technique will help ensure an appropriate flexion gap. The resected portion of the medial femoral condyle should be at least 9mm, while the resected portion of the lateral femoral condyle will be dictated by the degree of femoral component rotation. With posterior referencing, it may be necessary to upsize the femur to avoid notching the anterior cortex. If the distal femur was resected in 3° of flexion, notching of the anterior femur is less likely to occur. This option can be helpful when in between femoral sizes, especially when using a posterior referencing technique. If an anterior referencing technique is used, be aware of the amount of posterior condylar resection, since the variable cut is now posterior. Avoid resection greater than 10mm from the posterior medial condyle (Fig.4).

Fig. 4

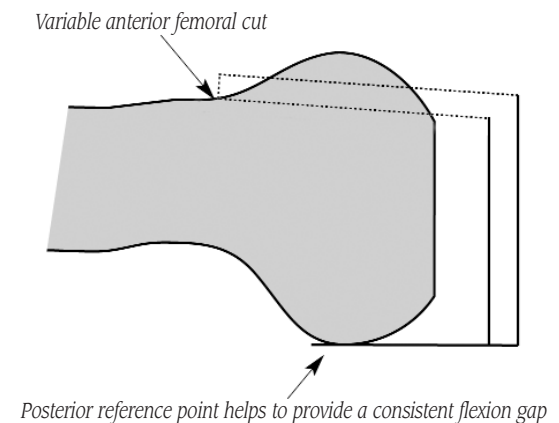

DETERMINE EXTERNAL ROTATION

Posterior referencing instrumentation systems like the *Multi-Reference 4-in-1* Instruments are designed to help balance the flexion and extension gaps with the initial bone cuts. **The critical goal is to create a rectangular and symmetrical flexion gap between the femur and tibia.**

It is necessary to externally rotate the femoral component in order to create a symmetrical flexion gap. Depending on the preoperative alignment of the knee, external rotation can be set by referencing either the posterior condyles or the transepicondylar axis.

Referencing the Posterior Condyles

The posterior condyles can be used for a knee that is in varus or neutral alignment without posterior condyle bone loss. When referencing from the posterior condyles, the femoral component should be externally rotated 3°. When the A/P Sizing/Rotation Guide is placed on the femur, both feet of the guide should be contacting the posterior condyles.

Referencing the Transepicondylar Axis

The transepicondylar axis provides a reproducible method of setting femoral rotation for all knees, and is appropriate method for knees in valgus alignment. The anteroposterior axis of the femur provides an additional rotational landmark when using the transepicondylar axis.

To identify the lateral epicondyle, dissect away the patellofemoral ligament. The lateral epicondyle is a discrete point at the center of the lateral collateral ligament attachment.

To identify the medial epicondyle, remove the synovium from the medial collateral ligament attachment to the femur. The medial collateral ligament has a broad attachment to the medial epicondyle forming an approximate semicircle (Fig. 5). Choose the center of the attachment. Mark these two points with methylene blue (Fig. 6). Then, draw a line between the two epicondyles on the resected surfaces of the distal femur (Fig. 7). This line represents the transepicondylar axis.

Fig. 5

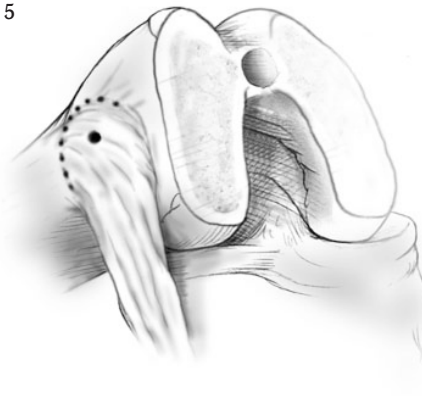

Fig. 6



Fig. 7



When establishing the mediolateral position of the femoral component, it is recommended to lateralize the component to help improve patellar tracking. Avoid positioning the component where it overhangs the bone as this may restrict flexion.

With the knee in flexion, remove posterior osteophytes with a 3/4-inch curve-on-flat osteotome (Fig. 8). Use a laminar spreader and the Posterior Femoral Retractor to improve exposure (Fig. 9).

Fig. 8



Fig. 9

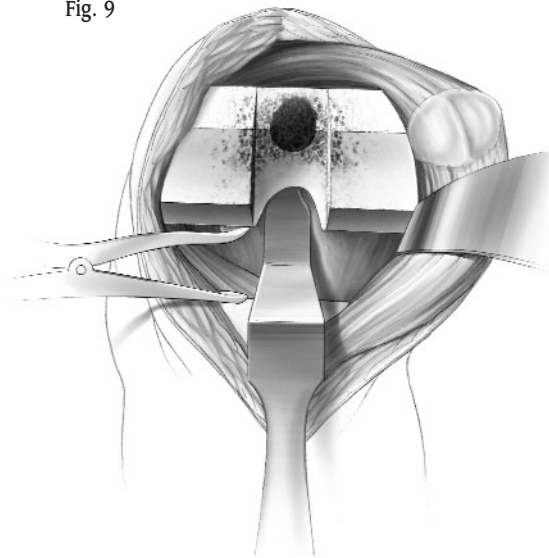

TIBIAL PREPARATION

Using the selected instrumentation system, and following the appropriate technique for that system, establish the tibial cutting platform and resect the proximal tibia. Using a .050in/1.27mm saw blade and an oscillating saw to cut the proximal tibia taking care not to resect the cruciate island. A reciprocating saw can be used to aid in resecting around the cruciate island (Fig. 10).

Fig. 10

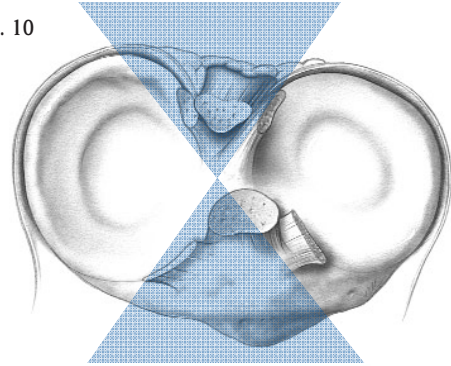

POSTERIOR CONDYLE RECUT

Technique Tip

This step can be performed after cutting the tibia to allow easy access to the popliteal fossa and facilitate osteophyte removal.

To accommodate the thickened posterior condyle of the CR-Flex Femoral Component, a posterior condyle recut must be made. Insert the Posterior Femoral Retractor to help protect the neurovascular structures. Select the Posterior Recut Guide that matches the size of the last cutting guide used for the femur. Position the guide so it is flush with the cut bone surfaces (Fig. 11) and is aligned with the trochlear recess. If the femoral post holes have been drilled previously, screw the Recut Guide Modular Pegs into the guide to aid in positioning.

Fig. 11



When positioning the Posterior Recut Guide, ensure that the guide goes on straight to prevent the guide from sitting in flexion. Check to ensure that the Posterior Recut Guide does not impinge on bone or soft tissue either anteriorly or posteriorly. Protect the medial collateral ligament and the posterior cruciate ligament.

Cut the posterior condyles through the posterior cutting slot of the recut guide using an oscillating saw with a .050in/1.27mm blade (Fig. 12). This cut will remove approximately 2mm from the posterior condyles. If post holes have not been drilled, this instrument can be used to drill for the femoral post holes.

Fig. 12



Note: For size B femoral components, you must use the Posterior Recut Guide to drill the size A/B femoral post holes with the A/B Femoral Peg Drill (Fig. 13).

Fig. 13



Check to ensure that there is no bone left beyond the feet of the Posterior Recut Guide. The length of the posterior condyle of the recut guide represents the length of the medial posterior condyles of the femoral implant.

With all femoral and tibial bone cuts completed, it is easy to visualize the posterior condyles and popliteal recess. This allows removal of loose bodies and any posterior osteophytes. Use a laminar spreader or the Posterior Femoral Retractor to improve exposure. An elevator can be used to release any adhesions and then the posterior osteophytes removed with an osteotome. Remove all fragments of bone, loose bodies and osteophytes.





FINISH THE TIBIA

Select the proper style of Tibial Sizing Plate (for either stemmed or pegged tibias) and the plate size that provides the desired tibial coverage (Fig. 14). Base the selection first on achieving good mediolateral coverage, and then on anteroposterior coverage. Be sure to rotationally position the plate correctly. This position usually leaves some bone exposed on the posterior medial tibia when the plate lines up with the posterior lateral cortex.

Fig. 14

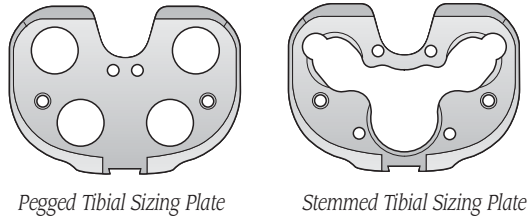

Technique Tip:

Consider biasing the plate posteriorly to help ensure femoral support during high flexion and to minimize potential impingement.

The Articular Surface Provisional has an alphanumeric code. Compare the letters on the selected Articular Surface Provisional to the letter on the selected Femoral Provisional. One of the letters on the Articular Surface Provisional must match the letter on the Femoral Provisional. If the Articular Surface Provisional does not match the Femoral Provisional, adjust the size of the Articular Surface Provisional to yield a match. Then compare the range of numbers on the Articular Surface Provisional to the number on the Tibial Sizing Plate. The number on the sizing plate must be within the range on the Articular Surface Provisional. If the Articular Surface Provisional does not

match the Tibial Sizing Plate, adjust the size of the sizing plate to yield a match.

(See Sizing Chart on page 15).

The tibia can be finished prior to trial reduction if the implant position will be chosen based on anatomic landmarks. Alternatively, the provisionals, in combination with the sizing plate, can be used to perform a trial range of motion to aid in tibial location.

If the tibial position will be based on anatomic landmarks, position the sizing plate rotationally by referencing the line that defines the tibial A/P axis, from the PCL to the junction of the medial and mid-third of the tibial tubercle.

If the tibial position will be based on a trial reduction, prepare the patella. Then perform a trial reduction and balance all ligaments (Prepare the Patella).

Pin the plate in place and drill for the appropriate pegged or stemmed component. If a stemmed component will be implanted, broach the tibia.

Note: The stemmed plate must be used with a 17mm or 20mm Net-Shape molded or Prolong™ Highly Crosslinked Polyethylene articular surface. (See technique on page 16)

PREPARE THE PATELLA

The patella can be prepared for resurfacing using a number of techniques. With any technique, it is important to measure the patellar thickness before preparation and be very careful not to increase the thickness of the patellar construct. This will artificially tighten the extensor mechanism, leading to lateral releases and limited flexion. It is also important to bias the placement of the symmetric patellar component medially so that the central thick dome will be located medially in line with the anatomic central ridge.

BALANCE SOFT TISSUES

The objective of this procedure should be to distribute contact stresses across the artificial joint as symmetrically as possible with the knee in an anatomic position. This requires the creation of equal and symmetrical flexion and extension gaps. Varus or valgus deformities should be corrected before flexion contractures. All of these releases are performed after the bone cuts are completed.

VARUS RELEASES

To correct most fixed varus deformities (Fig. 15), progressively release the tight medial structures until the medial and lateral spaces are equal in flexion and extension. The extent of the release can be monitored by inserting progressively thicker trials within the tibiofemoral joint and judging balance by evaluating the tension of the joint. To facilitate the release, excise all osteophytes from the medial femur and tibia. These osteophytes "tent" the medial capsule and ligamentous structures, and their removal can produce a correction before beginning the soft tissue release.

Fig. 15

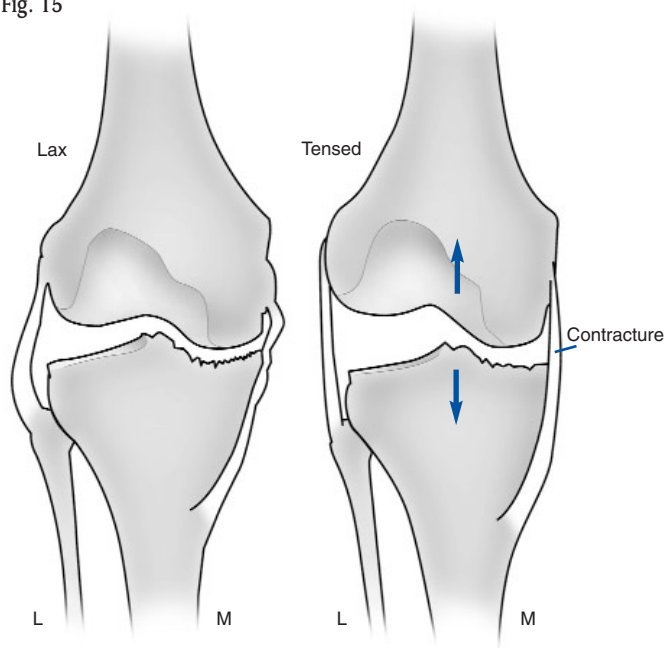

To release the tight medial structures, elevate a subperiosteal sleeve of soft tissue from the proximal medial tibia in a stepped fashion. Begin with the superficial medial collateral ligament. Perform this release with a periosteal elevator. Continue the subperiosteal release distally on the anteromedial surface of the tibia for up to 8cm-10cm.



This should be sufficient for most deformities. For more severe deformities, continue subperiosteal stripping posteriorly and distally. Release of the insertion of the semimembranosus muscle from the posteromedial tibia, or the pes anserinus tendons, is occasionally necessary. Rarely, the posterior cruciate ligament must also be released. During large releases, be careful to avoid creating a larger flexion gap medially than laterally. When varus misalignment is present with a flexion contracture, it may be necessary to release the posterior capsule. This should be done after correction of the varus deformity.

VALGUS RELEASES

In knees that have a fixed valgus deformity (Fig. 16), sequential releases can usually correct this abnormality. In making the bone cuts, it is important to recognize the frequently hypoplastic lateral femoral condyle and avoid internal rotation of the femoral component. With the trial implants in position, evaluate the tightness of the lateral compartment in flexion and extension. If the knee is excessively tight in extension and appropriate in flexion, selectively loosen the iliotibial band with multiple punctures above the joint line using a #11 or #15 knife blade. If the knee is excessively tight in flexion and appropriately tight in extension, subperiosteal release of the lateral collateral ligament and possibly the popliteus off the lateral femoral condyle will correct this problem. If the knee is too tight laterally in flexion and extension, start with the lateral collateral ligament and advance sequentially through the popliteus and iliotibial band. After each release of a lateral structure, repeat the trial reduction

with progressively thicker tibial articular surfaces. When tibiofemoral stability in flexion and extension has been achieved with equal tension in the medial and lateral compartments, evaluate patellofemoral tracking. Make appropriate adjustments in the extensor mechanism to allow the patella to track centrally.

Fig. 16

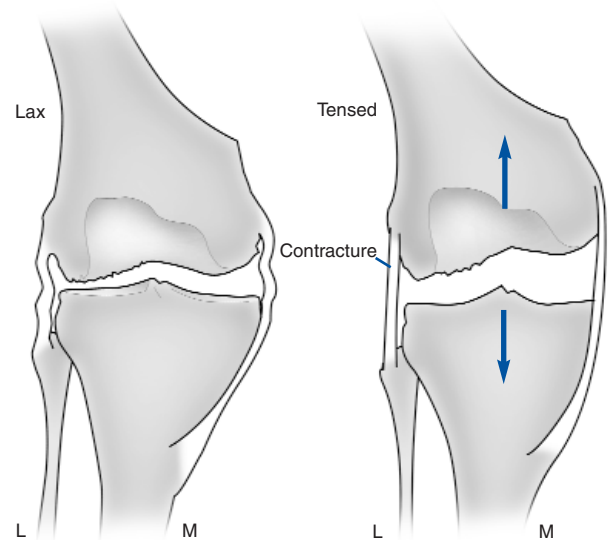

TRIAL REDUCTION

Place the Femoral Provisional, the Tibial Plate Provisional, the Articular Surface Provisional, and the Patellar Provisional (if needed) onto the prepared bone surfaces.

With all the provisional components in place, perform a complete range of motion (Fig. 17).

Observe patellar tracking and tilt.

Fig. 17

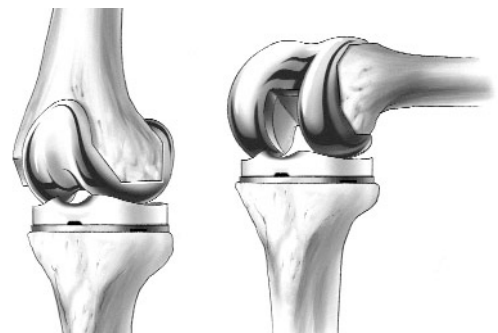

If the knee is tight in flexion and acceptable in extension, the surgeon has the option of using a Minus size femoral component to balance the flexion and extension gaps. The Minus sizes have a 2mm reduction in the outer A/P dimension of the femoral component.

No additional femoral cuts need to be made. The regular size provisional is switched out for the Minus size and complete range of motion is performed again (Fig. 18).

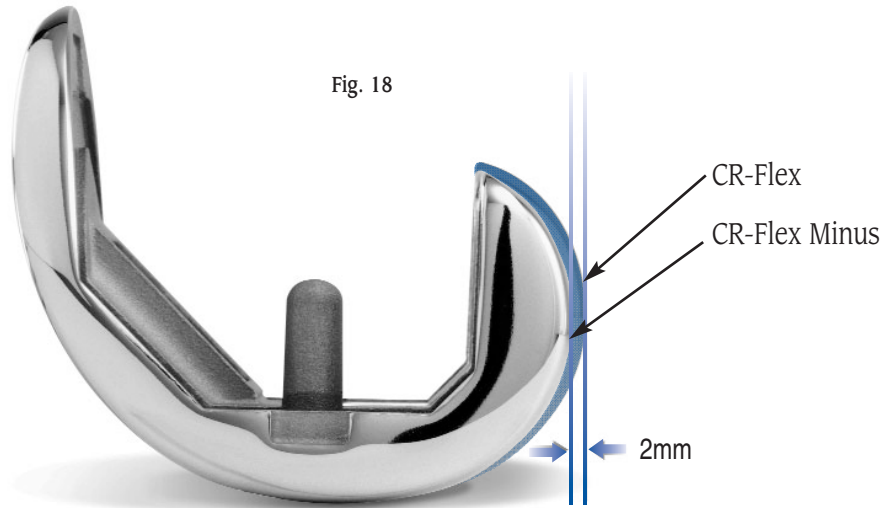

CR-Flex Femur



CR-Flex Provisional



CR-Flex Minus Size Femur



CR-Flex Minus Provisional



BALANCE FLEXION AND EXTENSION GAPS

After varus or valgus deformities are corrected, the flexion and extension gaps must be balanced or adjusted to be equal. This may be facilitated by using the minus size femoral components available with the *NexGen CR-Flex Fixed Bearing Knee System*. These implants fit the same box cut but the outer A/P dimension is approximately 2mm smaller posteriorly than the standard size. These additional implant options allow the surgeon to balance the gaps when the knee is too tight in flexion and correct in extension. With the trial femoral component in place, insert progressively thicker tibial articular surfaces. When the knee is stable in flexion, extend the knee. A symmetrical and balanced extension gap should be created. This is occasionally difficult as it may require elevation or lowering of the joint line. The patella helps determine the appropriate position of the joint line.

It is important to remember that adjustments to the femoral side of the arthroplasty can affect the knee in either flexion or extension, while any change to the tibia affects both flexion and extension. The following matrix (Fig. 19) suggests the nine situations that can occur during a trial reduction in a total knee arthroplasty.

Fig. 19

		EXTENSION		
		Tight	OK	Loose
FLEXION	Tight	1	2	3
	OK	4	5	6
	Loose	7	8	9

1. If a knee is too tight in both flexion and extension, reducing the height of the tibial articular surface may be sufficient to balance the construct.
2. If the knee is tight in flexion but acceptable in extension, three options exist. One option is to use a Minus size femoral component. This creates more space in flexion. The second option is to release the PCL either by island osteotomy or ligament release, both of which lengthen the ligament. A third option is to cement the femoral component distal of the bone cut. This augmentation with cement distally fills the extension space when used with a thinner tibial articulating surface.
3. If the joint is loose in extension and tight in flexion one option is to use a smaller or Minus size femoral component possibly with a thicker polyethylene component.
4. If the joint is acceptable in flexion but tight in extension, several options exist. One is to release the posterior capsule from the femur. Another alternative is to resect more distal femoral bone. This moves the femoral component proximally on the femur at the expense of elevating the joint line.
5. If both components are acceptable, no further modification is necessary.

6. If the joint is acceptable in flexion and loose in extension, consider downsizing the femoral component to a Minus size. If the femoral component cannot be downsized, cement the femoral component distal of the bone cut. This augmentation with cement distally fills the extension space when used with a thinner tibial articulating surface.
7. If the joint is loose in flexion and tight in extension, a larger femoral component may suffice. A second option is a thicker tibial articular surface with a more proximal femoral position. A third option is a thicker tibial component combined with a posterior release.
8. If the joint is loose in flexion and acceptable in extension, increasing the femoral size may equalize the gaps. Alternatively, moving the femoral component proximally and applying a thicker tibial articular surface will equalize the gaps. Another option is to fill the flexion gap with the appropriate poly and perform a posterior release to increase the extension gap.
9. If a joint is symmetrically loose in both flexion and extension, a thicker tibial articular surface will usually solve both problems.

In situations where two options exist to help solve the soft tissue mismatch, the position of the patella or the joint line help the surgeon decide which option to select.

Note: after applying one of these solutions, perform another trial reduction. This will identify any new problem or a variation of the initial problem that now may exist.

IMPLANTATION

After the implants have been chosen, make one last check to ensure that the femoral, tibial base plate, and tibial articular surface components match. The femoral letter must match one of the letters on the articular surface carton as indicated by the interchangeability chart (Fig. 20).



Fig. 20

		NEXGEN CRUCIATE RETAINING FLEX (CR-FLEX)					
		FEMORAL SIZE					
NexGen ^{System}		B	C,C-	D,D-	E,E-	F,F-	G,G-
M/L (mm)		58	60	64	68	72	76.5
A/P (mm)		48.5	53.5/51.5	57.5/55.5	61.5/59.5	65.5/63.5	70.5/68.5
A/P Box (mm)		36	38	42	46	50	54
Bearing Spacing (mm)		36					44
TIBIAL SIZE	1,2	P	SP	SP	SP	SP	SP
	3,4	SY	Y	Y	Y	Y	Y
	5,6	SG	G	G	G	G	G
	7,8,9,10		B	B	B	B	B
PATELLA SIZE		Micro 26mm 5972-61-26 29mm 5972-61-29 32mm 5972-61-32 35mm 5972-61-35		Standard 26mm 5972-65-26 29mm 5972-65-29 32mm 5972-65-32		Standard 35mm 5972-65-35 38mm 5972-65-38 41mm 5972-65-41	

COLOR KEY
 P = Purple
 Y = Yellow
 G = Green
 B = Blue
 SP = Striped Purple
 SY = Striped Yellow
 SG = Striped Green

Insert the appropriate size femoral and tibial components. Then use the Articular Surface Inserter to attach the appropriate tibial articular surface onto the plate.



Techniques for 17mm and 20mm Articular Surface Assembly

A secondary locking screw is required for the 17mm and 20mm articular surface components when used with CR-Flex components. **Therefore, stemmed tibial plates with either a stem extension or taper plug must be used with these thicker components (Fig. 21). This assists in lift off resistance at higher flexion positions.**

Fig. 21



*Note: The pegged plate **cannot** be used with the 17 or 20mm Net-Shape molded or Prolong polyethylene articular surface.*

With the *Prolong* Highly Crosslinked Polyethylene articular surface option, the locking insert and screw are packaged separately from the articular surface component in the same box. Prior to inserting the articular surface, the metal locking insert must first be inserted into the anterior slot of the articular surface. The rail should be aligned with the space in the slot. There is an arrow on the superior side of the locking clip that indicates the correct direction for insertion. The purpose of the rail is to prevent the insert from being assembled incorrectly. The metal insert should glide easily into the slot. The insert is properly seated when a click is heard. For the molded articular surface, the metal locking insert is preassembled into the articular surface.

A taper plug also can be used with the 10mm to 14mm articular surface components. If you plan to use a 14mm component or the flexion and extension gaps are not balanced, consider using the taper plug in case, during final trial reduction, it would be necessary to use a 17mm or 20mm component. Then, if the articular surface should ever require revision with a 17mm or 20mm thick component, the taper plug is already in place and revision of the tibial plate component may not be necessary.

For Back Table Assembly:

1. Assemble the stem extension or taper plug onto the tibial plate by striking it with a mallet once for the stem extension or several times for the taper plug to allow the ring on the taper to deform.
2. Place the tibial plate onto the holding fixture which is an integral part of the instrument case.
3. Use the articular surface Inserter to insert the articular surface onto the tibial plate.
4. With the articular surface in place, insert the secondary locking screw (packaged with the articular surface).
5. Use the LCCK Deflection Beam Torque Wrench with the 4.5mm Hex Driver Bit attached to torque the screw to 95 in.- lbs. Alternatively, if using a stem extension, use the Tibial Plate Wrench to assist when torquing the screw. **Do not over or under torque.**

For in vivo Assembly:

If preferred, the 17mm or 20mm articular surface can be inserted after the tibial plate has been implanted.

1. Assemble the stem extension or taper plug onto the tibial plate by striking it several times with a mallet to allow the ring on the taper to deform.
2. Implant the tibial plate. If bone cement is being used, wait for the cement to completely cure before inserting the articular surface.
3. Select the Tibial Plate Wrench that matches the size of the implant to be assembled. Place the end of the wrench over the tibial plate. Ensure that the wrench is in line with the base of the tibial plate.
4. Place the locking screw through the hole in the articular surface.
5. Use the LCCK Deflection Beam Torque Wrench attached to the 4.5mm Hex Driver Bit to torque the screw to 95 in.-lbs.



CLOSURE

Close the knee and perform a drop and dangle test to predict the range of motion for the patient (Fig. 22).

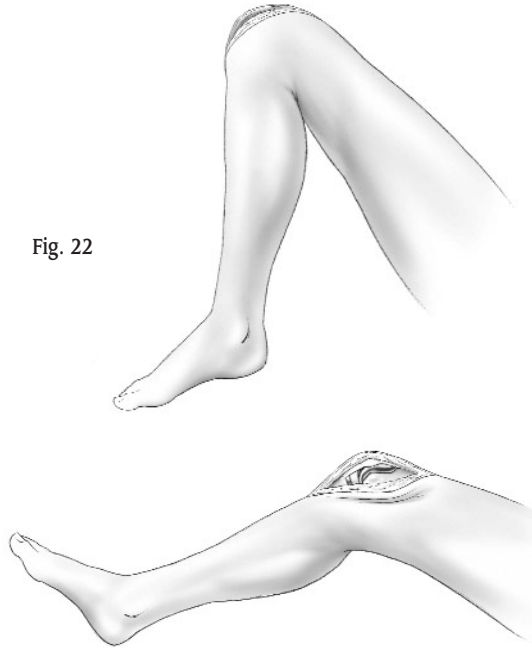

Fig. 22

REHABILITATION PROTOCOL

An equally important factor in gaining or maintaining high flexion after successful total knee arthroplasty is early and/or aggressive rehabilitation of the patient. Many of the standard rehabilitation protocols used in most hospitals today are aimed at restoring knee motion and function between 90° and 110°, which is sufficient for the TKA patient to get into or out of a chair or a car. Those patients undergoing TKA who are able and willing to flex and wish to maintain preoperative flexibility may be better off with early and/or relatively more aggressive rehabilitation exercises.

APPENDIX

CROSSOVER TECHNIQUES

(When crossing over to a high-flexion posterior stabilized design)

Note: When crossing to a posterior stabilized design after the posterior recut is made, the LPS-Flex Components must be used as opposed to the standard LPS Components. The only additional bone cut which needs to be made is the PS notch cut. It can be accomplished with the following technique.

Crossover Technique with the EPI Notch/Chamfer Guide

Select the EPI Notch/Chamfer Guide that is the same size as the A/P Cutting Guide used in the previous step. Place the EPI Notch/Chamfer Guide flush with the anterior and distal surfaces of the femur (Fig. 23).

Fig. 23

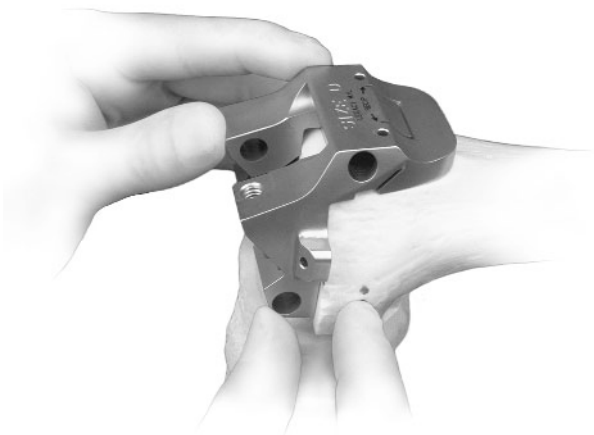

Position the guide mediolaterally, using the anterior portion of the guide to replicate the location for the anterior lateral flange of the femoral component. This is important because it dictates the mediolateral positioning of the femoral component. Also, the width of the guide equals the distal width of the Legacy® LPS and LPS-Flex femoral component. (Pin the anterior flange first to stabilize the M/L position.) Finish the box cut by cutting the base of the intercondylar notch with a reciprocating or narrow oscillating sawblade (Fig. 24).

Fig. 24

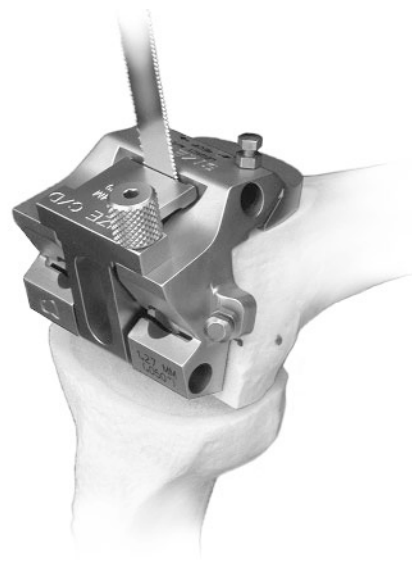

Use a reciprocating sawblade or narrow oscillating blade to first cut the base of the trochlear recess (Fig. 25). Cut the sides of the trochlear recess through the slot with a reciprocating sawblade.

Fig. 25

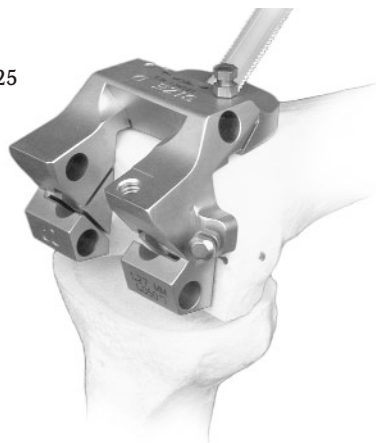



zimmer
Confidence in your hands™

