

**NFPA 402**  
Guide for  
Aircraft Rescue and Fire-Fighting Operations  
2002 Edition

Copyright © 2002, National Fire Protection Association, All Rights Reserved

This edition of NFPA 402, *Guide for Aircraft Rescue and Fire-Fighting Operations*, was prepared by the Technical Committee on Aircraft Rescue and Fire Fighting and acted on by NFPA at its May Association Technical Meeting held May 19–23, 2002, in Minneapolis, MN. It was issued by the Standards Council on July 19, 2002, with an effective date of August 8, 2002, and supersedes all previous editions.

This edition of NFPA 402 was approved as an American National Standard on July 19, 2002.

**Origin and Development of NFPA 402**

These standard operating procedures were first developed by the sponsoring NFPA committee in 1947 and were first adopted by the Association in 1949. They were amended in 1951, 1969, 1973, and 1978. In 1984, the Committee combined the text of NFPA 406M, *Manual on Aircraft Rescue and Fire Fighting Techniques for Fire Departments Using Structural Fire Apparatus and Equipment*, with the text of NFPA 402, *Recommended Practice for Aircraft Rescue and Fire Fighting Operational Procedures for Airport Fire Departments*, and reidentified the document as NFPA 402M. The entire texts of both NFPA 402 and NFPA 406M were revised to create NFPA 402M. The 1989 edition of NFPA 402M was a complete revision of the manual. This guide was revised again in 1991.

The aircraft figures were deleted for the 1996 edition. A comprehensive collection of figures is now available in a publication titled *NFPA Aircraft Familiarization Charts Manual*.

The 2002 edition is a partial revision.

**Technical Committee on Aircraft Rescue and Fire Fighting**

**Brian Boucher, Chair**

Air Canada Pilots Association, NY [L]

**Lawrence V. Powers, Secretary**

Massport, MA [U]

**Keith W. Bagot**, U.S. Federal Aviation Administration, NJ [RT]

**Tony Cash**, United Kingdom Civil Aviation Authority, England [E]

**Ralph Colet**, John Russo Industrial, Inc., CA [M]

**Robert L. Darwin**, Hughes Associates, Inc., MD [SE]

**Ross A. Davidson**, U.S. Navy Air Warfare Center Weapons Division, CA [U]

**Roger Davis**, BAA PLC Heathrow Airport, England [U]

**Derek K. G. Dodwell**, Serco Aviation Services, England [U]

**David A. Enz**, Tucson Airport Authority, AZ [U]  
Rep. Airports Council International, Inc.—North America

**Kenneth R. Gilliam**, Federal Aviation Administration, FL [E]

**B. V. Hewes**, Airport Safety Services, GA [SE]

**Donald E. Hilderbrand**, Phoenix Fire Department, AZ [L]

**L. M. Krasner**, Factory Mutual Research Corporation, MA [I]

**Paul S. Meyer**, Hartsfield Atlanta International Airport/City of Atlanta, GA [U]

**John J. O'Sullivan**, British Airways, PLC, England [C]

**Gaétan Perron**, National Defense Headquarters (CFFM-2), Canada [U]

**Thomas Phillips**, Airline Pilots Association, PA [L]

**Pam Phillips**, Port Authority of New York & New Jersey, NY [U]  
Rep. American Association of Airport Executives

**Hugh A. Pike**, U.S. Air Force Fire Protection, FL [U]

**Lee W. Prazer**, Akron Brass Company, OH [M]

**Richard M. Radford**, Dubai International Airport, United Arab Emirates [E]

**Michael D. Reagan**, Los Angeles City Fire Department, CA [U]

**Robert G. Relyea**, ARFF Working Group, TX [M]

**John M. Schuster**, 3M Company, MN [M]

**Terry Seaborn**, Oshkosh Truck Corporation, WI [M]

**Robert L. Shaub**, Emergency One, Inc., FL [M]

**Bernard Valois**, Transport Canada Civil Aviation, Canada [E]

**Ronald O. Wikander**, LM Aero, GA [M]

**Joseph A. Wright**, ARFF Technical Services, Inc., FL [SE]

### **Alternates**

**Ali Zaid Mohamed Al Balushi**, Directorate General of Civil Aviation & Meteorology, Seeb [E]  
(Alt. to R. M. Radford)

**Darrin Barth**, Hartsfield Atlanta International Airport/City of Atlanta, GA [U]  
(Alt. to P. S. Meyer)

**Michael P. Crowe**, Oshkosh Truck Corporation, WI [M]  
(Alt. to T. Seaborn)

**Robert J. Donahue**, Massport, MA [U]  
(Alt. to L. V. Powers)

**Christopher Farnaby**, United Kingdom Civil Aviation Authority, England [E]  
(Alt. to T. Cash)

**James Hotell**, U.S. Air Force Fire Protection, FL [U]  
(Alt. to H. A. Pike)

**Frank M. E. Hughes**, British Airways, PLC, England [C]  
(Alt. to J. J. O'Sullivan)

**Madhu Manikkam**, Emergency One, Inc., FL [M]  
(Alt. to R. L. Shaub)

**Richard B. Mills**, Akron Brass Company, OH [M]  
(Alt. to L. W. Prazer)

**Gaétan Morinville**, Canadian Forces, Canada [U]  
(Alt. to G. Perron)

**James F. O'Regan**, O'Regan Consulting, MA [M]  
(Alt. to R. Colet)

**Richard E. Ottman**, 3M Company, MN [M]  
(Alt. to J. M. Schuster)

**Paul R. Robinson**, Airline Pilots Association, Chattanooga, TN [L]

(Alt. to T. Phillips)

**Joseph L. Scheffey**, Hughes Associates, Inc., MD [SE]

(Alt. to R. L. Darwin)

**Gary T. Schott**, Omaha Airport Authority, NE [M]

(Alt. to R. G. Relyea)

**Bernard Stone**, BAA PLC Gatwick Airport, England [U]

(Alt. to R. Davis)

**Thomas Van Mai**, Federal Aviation Administration, DC [E]

(Alt. to K. R. Gilliam)

**Craig Williams**, American Association of Airport Executives, VA [U]

(Alt. to P. Phillips)

**Bonnie Wilson**, Airports Council International North America, DC [U]

(Alt. to D. A. Enz)

### **Nonvoting**

**Mark Day**, Carmichael International Limited, England

**Gary Hammack**, U.S. National Transportation Safety Board, DC

**Thomas J. Lett**, Albuquerque Fire & Safety Associates, NM

(Member Emeritus)

**David F. Short**, Charlton Kings, Cheltenham, England

**Francois Villard**, Geneva International Airport, Switzerland [U]

**Mark T. Conroy**, NFPA Staff Liaison

**Committee Scope:** This Committee shall have primary responsibility for documents on aircraft rescue and fire-fighting services and equipment, for procedures for handling aircraft fire emergencies, and for specialized vehicles used to perform these functions at airports, with particular emphasis on saving lives and reducing injuries coincident with aircraft fires following impact or aircraft ground fires. This Committee also shall have responsibility for documents on aircraft hand fire extinguishers and accident prevention and the saving of lives in future aircraft accidents involving fire.

*This list represents the membership at the time the Committee was balloted on the final text of this edition. Since that time, changes in the membership may have occurred. A key to classifications is found at the back of the document.*

NOTE: Membership on a committee shall not in and of itself constitute an endorsement of the Association or any document developed by the committee on which the member serves.

### **NFPA 402 Guide for**

## **Aircraft Rescue and Fire-Fighting Operations 2002 Edition**

NOTICE: An asterisk (\*) following the number or letter designating a paragraph indicates that explanatory material on the paragraph can be found in Annex A.

Changes other than editorial are indicated by a vertical rule beside the paragraph, table, or figure in which the change occurred. These rules are included as an aid to the user in identifying changes from the previous edition. Where one or more complete paragraphs have been deleted, the deletion is indicated by a bullet between the paragraphs that remain.

A reference in brackets [ ] following a section or paragraph indicates material that has been extracted from another NFPA document. As an aid to the user, Annex H lists the complete title and edition of the source documents for both mandatory and nonmandatory extracts. Editorial changes to extracted material consist of revising references to an appropriate division in this document or the inclusion of the document number with the division number when the reference is to the original document. Requests for interpretations or revisions of extracted text shall be sent to the appropriate technical committee.

Information on referenced publications can be found in Chapter 2 and Annex H.

### **Chapter 1 Administration**

#### **1.1 Scope.**

**1.1.1** This guide provides information relative to aircraft rescue and fire-fighting operations and procedures for airport and structural fire departments.

**1.1.2** Statistics indicate that approximately 80 percent of all major commercial aircraft accidents occur in the critical rescue and fire-fighting access area. This is the primary response area for airport-based ARFF services. Approximately 15 percent of the accidents occur in the approach areas. In such instances the community/mutual services could be the prime responders.

**1.1.3** Some airport fire departments have the total fire prevention and fire protection responsibility for the entire airport, including structural fire-fighting responsibilities in terminal buildings, aircraft hangars, airport hotels, cargo buildings, and other facilities. Procedures for these fire prevention and protection operations are not covered in this guide.

#### **1.2 Purpose.**

**1.2.1** This guide has been prepared for the use and guidance of those charged with the responsibility of providing and maintaining aircraft rescue and fire-fighting (ARFF) services on airports.

**1.2.2** The guide's content is also intended for the use of structural fire departments to assist them in developing methods to effectively handle aircraft incidents that might occur within their jurisdiction. It also provides for a basis of understanding, relative to emergencies on airports, that would enhance structural fire departments' effectiveness when called to assist airport fire departments.

#### **1.3 General.**

**1.3.1** Providing protection for the occupants of an aircraft takes precedence over all other operations. Fire control is frequently an essential condition to ensure such survival. The objectives of the airport fire

department should be to respond to any aircraft emergency in the minimum possible time and employ rescue and fire-fighting techniques effectively. These objectives can be accomplished when properly trained personnel work together as a team and apply the operational procedures presented in this guide.

**1.3.2** Governmental and organizational publications frequently referenced in this guide can be found in Annex H.

**1.3.3** If a value for measurement as given in this guide is followed by an equivalent value in other units, the first stated is to be regarded as the requirement. A given equivalent value might be approximate.

**1.3.4** Metric units of measurement in this guide are in accordance with the modernized metric systems known as the International System of Units (SI). One unit (liter), outside of, but recognized by SI, is commonly used in international fire protection.

## Chapter 2 Referenced Publications

### 2.1 General.

The documents or portions thereof listed in this chapter are referenced within this guide and should be considered part of the recommendations of this document.

### 2.2 NFPA Publications.

National Fire Protection Association, 1 Batterymarch Park, P.O. Box 9101, Quincy, MA 02269-9101.

NFPA 403, *Standard for Aircraft Rescue and Fire-Fighting Services at Airports*, 1998 edition.

NFPA 405, *Recommended Practice for the Recurring Proficiency Training of Aircraft Rescue and Fire-Fighting Services*, 1999 edition.

NFPA 407, *Standard for Aircraft Fuel Servicing*, 2001 edition.

NFPA 410, *Standard on Aircraft Maintenance*, 1999 edition.

NFPA 414, *Standard for Aircraft Rescue and Fire-Fighting Vehicles*, 2001 edition.

NFPA 424, *Guide for Airport/Community Emergency Planning*, 2002 edition.

NFPA 1003, *Standard for Airport Fire Fighter Professional Qualifications*, 2000 edition.

NFPA 1500, *Standard on Fire Department Occupational Safety and Health Program*, 2002 edition.

NFPA, *Aircraft Familiarization Charts Manual*, 1996 edition.

### 2.3 Other Publications.

#### 2.3.1 FAA Publication.

Federal Aviation Administration, 800 Independence Avenue, S.W., Washington, DC 20591 (Department of Transportation, 400 Seventh Street, S.W., Washington, DC 20590).

FAA Advisory Circular 150/5220-17A, *Design Standards for an Aircraft Rescue and Firefighting Facility*, Chapter 4, Mobile ARFF Training Devices.

#### 2.3.2 ICAO Publication.

Copyright NFPA

International standards and recommended practices are promulgated by the International Civil Aviation Organization, 1000 Sherbrooke Street West, Montreal, Quebec, Canada H3A-2R2.

*Airport Services Manual, Part 7: "Airport Emergency Planning,"* Second edition, 1991.

### **2.3.3 Research and Special Programs Administration Materials Transportation Bureau.**

Request for single free copy for emergency service organizations may be addressed to U.S. Department of Transportation, Materials Transportation Bureau, Attention: DMT-11, Washington, DC 20590.

*Guidebook for Hazardous Materials Incidents (1984 Emergency Response Guidebook),* DOT P 5800.3.

## **Chapter 3 Definitions**

### **3.1 General.**

The definitions contained in this chapter apply to the terms used in this guide. Where terms are not included, common usage of the terms applies.

### **3.2 NFPA Official Definitions.**

**3.2.1\* Approved.** Acceptable to the authority having jurisdiction.

**3.2.2\* Authority Having Jurisdiction (AHJ).** The organization, office, or individual responsible for approving equipment, materials, an installation, or a procedure.

### **3.3 General Definitions.**

**3.3.1 Air Accident Investigations Branch (AAIB).** A UK agency that is responsible for investigating and determining the probable cause of all British aircraft accidents.

### **3.3.2 Aircraft.**

**3.3.2.1 Pressurized Aircraft.** Sealed, modern-type aircraft within which the internal atmospheric pressure can be regulated.

**3.3.2.2 Turboprop Aircraft.** An aircraft powered by one or more turbine engines each of which drives a propeller.

**3.3.3 Aircraft Accident.** An occurrence during the operation of an aircraft in which any person involved suffers death or serious injury or in which the aircraft receives substantial damage.

**3.3.4 Aircraft Accident Pre-Incident Planning.** This term is used to describe the process of forecasting all factors that could possibly exist involving an aircraft accident that could bear upon the existing emergency resources. A pre-incident plan should define the emergency organizational authority and the responsibilities of all those involved.

**3.3.5 Aircraft Defueling.** See Fuel Servicing.

**3.3.6 Aircraft Familiarization.** Refers to the knowledge of vital information that rescue and fire-fighting personnel should learn and retain with regard to the specific types of aircraft that normally use the airport and other aircraft that might use the airport due to weather conditions at scheduled destinations.

**3.3.7 Aircraft Fire Fighting.** The control or extinguishment of fire adjacent to or involving an aircraft

following ground accidents/incidents. Aircraft fire fighting does not include the control or extinguishment of airborne fires in aircraft.

**3.3.8 Aircraft Incident.** An occurrence, other than an accident associated with the operation of an aircraft, that affects or could affect continued safe operation if not corrected. An incident does not result in serious injury to persons or substantial damage to aircraft.

**3.3.9 Aircraft Rescue and Fire Fighting (ARFF).** The fire fighting action taken to prevent, control, or extinguish fire involved or adjacent to an aircraft for the purpose of maintaining maximum escape routes for occupants using normal and emergency routes for egress. Additionally, ARFF personnel will enter the aircraft to provide assistance to the extent possible in the evacuation of the occupants. Although life safety is primary to ARFF personnel, responsibilities such as fuselage integrity and salvage should be maintained to the extent possible.

**3.3.10 Air-Cushioned Vehicle (ACV).** A vehicle that can travel on land and water.

**3.3.11 Airport (Aerodrome).** An area on land or water that is used or intended to be used for the landing and takeoff of aircraft and includes buildings and facilities.

**3.3.12 Airport Air Traffic Control (ATC).** A service established to provide air and ground traffic control for airports.

**3.3.13 Airport Familiarization.** Refers to the knowledge that rescue and fire-fighting personnel must maintain relative to locations, routes, and conditions that will enable them to respond quickly and efficiently to emergencies on the airport and those areas surrounding the airport.

**3.3.14 Aluminum.** A lightweight metal used extensively in the construction of aircraft airframes and skin sections.

**3.3.15 Area.**

**3.3.15.1 Critical Rescue and Fire Fighting Access Area.** The rectangular area surrounding any runway within which most aircraft accidents can be expected to occur on airports. Its width extends 150 m (500 ft) from each side of the runway centerline, and its length is 1000 m (3300 ft) beyond each runway end.

**3.3.15.2 Practical Critical Fire Area (PCA).** This area is two-thirds of the Theoretical Critical Fire Area (TCA). (*See also Theoretical Critical Fire Area.*)

**3.3.15.3 Theoretical Critical Fire Area (TCA).** The theoretical critical fire area (TCA) is a rectangle, the longitudinal dimension of which is the overall length of the aircraft, and the width includes the fuselage and extends beyond it by a predetermined set distance that is dependent on the overall width. Therefore, the aircraft length multiplied by the calculated width equals the size of the TCA.

**3.3.16 Auxiliary Power Unit (APU).** A self-contained power source, provided as a component of an aircraft, that is used to energize aircraft systems when power plants are not operating or when external power is not available.

**3.3.17 Backdraft.** A phenomenon that occurs when a fire takes place in a confined area such as a sealed aircraft fuselage and burns undetected until most of the oxygen within is consumed. The heat continues to produce flammable gases, mostly in the form of carbon monoxide. These gases are heated above their ignition temperature and when a supply of oxygen is introduced, as when normal entry points are opened, the gases could ignite with explosive force.

**3.3.18 Bogie.** A tandem arrangement of aircraft landing gear wheels. The bogie can swivel up and down so



that all wheels follow the ground as the attitude of the aircraft changes or the ground surface changes.

**3.3.19 Cockpit Voice Recorder (CVR).** A device that monitors flight deck crew communications through a pickup on the flight deck connected to a recorder that is usually mounted in the tail area of the aircraft and that is designed to withstand certain impact forces and a degree of fire.

**3.3.20 COMBI.** An aircraft designed to transport both passengers and cargo on the same level within the fuselage.

**3.3.21 Command Post (CP).** The location at the scene of an emergency where the incident commander is located and where command, coordination, control, and communications are centralized.

**3.3.22 Composite Materials.** Lightweight materials having great structural strength. They are made of fine fibers embedded in carbon/epoxy materials. The fibers are usually boron, fiberglass, aramid, or carbon in the form of graphite. Composite materials do not present unusual fire fighting problems, but products of their combustion should be considered a respiratory hazard to fire fighters.

**3.3.23 Dangerous Goods.** This term is synonymous with the terms *hazardous materials* and *restricted articles*. The term is used internationally in the transportation industry and includes explosives and any other article defined as a combustible liquid, corrosive material, infectious substances, flammable compressed gases, oxidizing materials, poisonous articles, radioactive materials, and other restrictive articles.

**3.3.24 Deck Gun (Deluge Set).** See Turret.

**3.3.25 Departure.** An aircraft taking off from an airport.

**3.3.26 Dry Chemical.** A powder composed of very small particles, usually sodium bicarbonate-, potassium bicarbonate-, or ammonium phosphate-based with added particulate material supplemented by special treatment to provide resistance to packing, resistance to moisture absorption (caking), and the proper flow capabilities. [17:3.3]

**3.3.27 Dry Powder.** Solid materials in powder or granular form designed to extinguish Class D combustible metal fires by crusting, smothering, or heat-transferring means. [10:3.3]

**3.3.28 Empennage.** The tail assembly of an aircraft, which includes the horizontal and vertical stabilizers.

**3.3.29 Evacuee.** An aircraft occupant who has exited the aircraft following an accident/incident.

**3.3.30 Exposure.** Any person or property that could be endangered by fire, smoke, gases, or runoff.

**3.3.31 Extinguishing Agent.**

**3.3.31.1 Complementary Extinguishing Agent.** Refers to an extinguishing agent that has the compatibility to perform fire suppression functions in support of a primary extinguishing agent and where extinguishment might not be achievable using only the primary agent.

**3.3.31.2 Primary Extinguishing Agent.** Agents that have the capability of suppressing and preventing the reignition of fires in liquid hydrocarbon fuels.

**3.3.32 Extinguishing Agent Compatibility.** Related to the requirement that the chemical composition of each agent be such that one will not adversely affect the performance of other agents that might be used on a common fire.

**3.3.33 Extrication.** The removal of trapped victims from a vehicle or machinery. [1670:1.3]

**3.3.34 Federal Aviation Administration (FAA).** An agency of the United States federal government charged

with the primary responsibility of regulating aviation activities.

### **3.3.35 Fire Classifications.**

**3.3.35.1 Class A.** Ordinary combustibles.

**3.3.35.2 Class B.** Flammable liquids.

**3.3.35.3 Class C.** Electrically charged components.

**3.3.35.4 Class D.** Combustible metals.

**3.3.36 Fire Wall.** A bulkhead designed to stop the lateral spread of fire in a fuselage or engine nacelle.

**3.3.37 Flashback.** The tendency of flammable liquid fires to re-ignite from any source of ignition after the fire has once been extinguished.

**3.3.38 Flashover.** A transition phase in the development of a contained fire in which surfaces exposed to thermal radiation reach ignition temperature more or less simultaneously and fire spreads rapidly throughout the space. [921:3.3]

**3.3.39 Flight Attendants.** Those members of the flight deck crew whose responsibility includes the management of activities within the passenger cabin.

**3.3.40 Flight Data Recorder (FDR).** An instrument that monitors performance characteristics of an aircraft in flight. It is usually mounted in the tail area of an aircraft and is designed to withstand certain impact forces and a degree of fire. Its purpose is to provide investigators with flight performance data that might be relevant in determining the cause of an accident/incident.

**3.3.41 Flight Deck Crew.** Those members of the crew whose responsibility includes the management of the aircraft's flight control and ground movements.

**3.3.42 Flight Technical Crew (FTC).** Includes pilots, flight engineers, and flight attendants who crew on aircraft movement.

### **3.3.43 Foam.**

**3.3.43.1 Aqueous Film Forming Foam Concentrate (AFFF).** A concentrated aqueous solution of one or more hydrocarbon and/or fluorochemical surfactants that forms a foam capable of producing a vapor-suppressing, aqueous film on the surface of hydrocarbon fuels. The foam produced from AFFF concentrates is dry chemical compatible and, therefore, is suitable for use in combination with that agent. [403:1.5]

**3.3.43.2 Film Forming Fluoroprotein (FFFP) Foam Concentrate.** A concentrate that uses fluorinated surfactants to produce a fluid aqueous film for suppressing hydrocarbon fuel vapors. This type of foam also utilizes a protein base plus stabilizing additives and inhibitors to protect against freezing, corrosion, and bacterial decomposition, and it also resists fuel pickup.

**3.3.43.3 Fluoroprotein Foam.** A protein-based foam concentrate to which fluorochemical surfactants have been added. This has the effect of giving the foam a measurable degree of compatibility with dry chemical extinguishing agents and an increase in tolerance to contamination by fuel.

**3.3.43.4 Protein Foam.** A protein-based foam concentrate that is stabilized with metal salts to make a fire-resistant foam blanket. [403:1.5]

**3.3.44 Foam Application Rate.** The amount of foam solution in liters or gallons per minute expressed as a

relationship with a unit of area, usually square meter or square foot.

**3.3.45 Foam Blanket.** A covering of foam over the surface of flammable liquids to provide extinguishment and prevent ignition.

**3.3.46 Foam Burnback Resistance.** The ability of a foam blanket to retain aerated moisture and resist destruction by heat and flame.

**3.3.47 Foam Drain Time.** The foam drain time — commonly the 25 percent drainage time (or ¼ drainage time) — is the time required for 25 percent of the original foam solution (foam concentrate plus water) to drain out of the foam.

**3.3.48 Forcible Entry.** The act of making entry into an aircraft or other structure when normal entry points are not accessible.

**3.3.49 Forward Looking Infrared (FLIR).** A thermal imaging system (camera) which can be vehicle-mounted designed to detect thermal energy.

**3.3.50 Frangible Gate/Fence.** Gates or fence sections designed to open, break away, or collapse when struck with the bumper of an ARFF vehicle responding to an emergency.

**3.3.51 Fuel Servicing.** Fueling and defueling of aircraft fuel tanks, not including aircraft fuel transfer operations and design of aircraft fuel systems during aircraft maintenance or manufacturing operations.

**3.3.52 Fuselage.** The main body of an aircraft.

**3.3.53 Gear.**

**3.3.53.1 Main Gear.** Refers to the two or more larger landing gear structures of an aircraft, as opposed to wing, nose, or tail gear assemblies.

**3.3.53.2 Nose Gear.** That mechanical part of a landing gear system mounted under the nose of an aircraft. It can be designed either as a stationary component or one that retracts into the fuselage.

**3.3.54 Grid Map.** A plan view of an area with a system of squares (numbered and lettered) superimposed to provide a fixed reference to any point in the area. [424:3.1]

**3.3.55 Halogenated Agent.** A liquefied gas extinguishing agent that extinguishes fire by chemically interrupting the combustion reaction between fuel and oxygen. Halogenated agents leave no residue.

**3.3.56 Halon 1211.** A halogenated agent whose chemical name is bromochlorodifluoromethane, CBrClF<sub>2</sub>, and that is a multipurpose, Class ABC-rated agent effective against flammable liquid fires. [408:1.3]

**3.3.57 Halon 1301.** A halogenated agent whose chemical name is bromotrifluoromethane, CBrF<sub>3</sub>, and that is recognized as an agent having Class ABC capability in total flooding systems. [408:1.3]

**3.3.58 Hazardous Materials.** A substance (solid, liquid, or gas) capable of creating harm to people, property, and the environment. [473:3.1] (*See Annex G.*)

**3.3.59 Hot Brakes.** A condition in which the aircraft's brake and wheel components have become overheated, usually due to excessive braking during landing.

**3.3.60\* Ignition Temperature.** Minimum temperature a substance should attain in order to ignite under specific test conditions. [921:1.3]

**3.3.61 Incident Commander (IC).** The person in overall command at an emergency.

**3.3.62 International Air Transport Association (IATA).** An international group composed of the major airlines of the world that reviews aviation policy including safety items.

**3.3.63 International Civil Aviation Organization (ICAO).** An international aviation body, operating under the auspices of the United Nations, that produces technical safety documents for civil air transport.

**3.3.64 Jet Blast.** The thrust-producing exhaust from a jet engine.

**3.3.65 Joint Aviation Authority (JAA).** An agency in Europe charged with the responsibility of regulating safety in civil aviation.

**3.3.66 Knockdown.** A fire fighting term defining the reduction of flame and heat to a point where further extension of a fire has been abated and the overhaul stage can begin.

**3.3.67 Magnesium.** Refers to either pure metal or alloys having the generally recognized properties of magnesium marketed under different trade names and designations.

**3.3.68 Master Stream.** A portable or fixed fire-fighting appliance supplied by either hose lines or fixed piping and that has the capability of flowing in excess of 300 gpm (1140 L/min) of water or water-based extinguishing agent. [600:1.5]

**3.3.69 Mutual Aid.** Reciprocal assistance by emergency services under a prearranged plan.

**3.3.70 National Transportation and Safety Board (NTSB).** A federal agency that is responsible for investigating and determining the probable cause of aircraft accidents.

**3.3.71 Overhaul.** A fire fighting term involving the process of final extinguishment after the main body of a fire has been knocked down. All traces of fire must be extinguished at this time.

**3.3.72 Penetrating Nozzle.** An appliance designed to penetrate the skin of an aircraft and inject extinguishing agent.

**3.3.73 Post Aircraft Accident.** The specific time when all fires have been extinguished, persons have been accounted for, survivors have been removed, and the hazards have been identified.

**3.3.74 Preservation of Evidence.** After an aircraft accident/incident it is imperative that investigative evidence be preserved after life safety and rescue operations have been concluded.

**3.3.75\* Protective Clothing.** Equipment designed to protect the wearer from heat and/or hazardous materials contacting the skin or eyes. [472:3.1]

**3.3.76 Rescue.** Those activities directed at locating endangered persons at an emergency incident, removing those persons from danger, treating the injured, and providing for transport to an appropriate health care facility.

**3.3.77 Rescue Path.** A fire-free path from an aircraft accident site to a safe area. This path, normally selected by evacuees, must be maintained by fire fighters during the evacuation process.

**3.3.78 Resources.** All personnel and major items of equipment that are available, or potentially available, for assignment to incidents. [1051:3.1]

**3.3.79 Response Time.** See Time.

**3.3.80 Restricted Articles.** See Dangerous Goods.

**3.3.81 Runoff.** Liquids that flow by gravity away from an aircraft accident and might include aviation fuel

(ignited or not), water from fire-fighting streams, liquid cargo, or a combination of these liquids.

**3.3.82 Runway.** A defined rectangular area on a land airport prepared for the landing and taking off of aircraft along its length. Runways are normally numbered relative to their magnetic direction.

**3.3.83 Salvage.** A fire fighting procedure for protecting property from further loss following an aircraft accident or fire.

**3.3.84 Self-Contained Breathing Apparatus (SCBA).** A respirator worn by the user that supplies a respirable atmosphere that is either carried in or generated by the apparatus and is independent of the ambient environment.

**3.3.85 Size-Up (Risk Assessment).** A mental process of evaluating the influencing factors at an incident prior to committing resources to a course of action. [1670:1.3]

**3.3.86 Skin.** The outer covering of an aircraft fuselage, wings, and empennage.

**3.3.87 Smoke Ejector.** A mechanical device, similar to a large fan, that can be used to force heat, smoke, and gases from a post-fire environment and draw in fresh air.

**3.3.88 Stabilizer.**

**3.3.88.1 Horizontal Stabilizer.** That portion of an aircraft's structure that contains the elevators.

**3.3.88.2 Vertical Stabilizer.** That portion of the aircraft's empennage that contains the rudder.

**3.3.89 Surface Movement Guidance and Control System (SMGCS).** A process or plan used by airports conducting operations in visibility conditions less than 366 m (1200 ft) runway visual range (RVR).

**3.3.90 Tabletop Training.** A workshop style of training involving a realistic emergency scenario and requiring problem-solving participation by personnel responsible for management and support at emergencies.

**3.3.91 Threshold.** The beginning of that portion of the runway usable for landing.

**3.3.92 Time.**

**3.3.92.1 Evacuation Time.** The elapsed time between an aircraft accident/incident and the removal of all surviving occupants.

**3.3.92.2 Response Time.** The total period of time measured from the time of an alarm until the first ARFF vehicle arrives at the scene of an aircraft accident and is in position to apply agent to any fire.

**3.3.93 Titanium.** Refers to either pure metal or alloys having the generally recognized properties of titanium metal, including the fire or explosion characteristics of titanium in its various forms.

**3.3.94 Triage.** The sorting of casualties at an emergency according to the nature and severity of their injuries.

**3.3.95 Triage Tag.** A tag used in the classification of casualties according to the nature and severity of their injuries.

**3.3.96 Turret.** A vehicle-mounted master stream appliance.

**3.3.97 Undercarriage.** All components of an aircraft landing gear assembly.

**3.3.98 United Kingdom Civil Aviation Authority (CAA).** An agency charged with the responsibility of regulating safety in civil aviation.

**3.3.99 Ventilation.** The changing of air within a compartment by natural or mechanical means. Ventilation

can be achieved by introduction of fresh air to dilute contaminated air or by local exhaust of contaminated air.  
[302:1.5]

**3.3.99.1 Mechanical Ventilation.** A process of removing heat, smoke, and gases from a fire area by using exhaust fans, blowers, air conditioning systems, or smoke ejectors.

## Chapter 4 Pre-Incident Planning for Aircraft Emergencies

### 4.1 General.

**4.1.1** Many accidents within the critical rescue and fire-fighting access area involve undershoots, overshoots, and rejected takeoffs, and are generally survivable. Accidents occurring outside of the critical rescue and fire-fighting access area could involve impact with adverse terrain with resultant rupture of the aircraft structure. Rapid response to these areas is crucial for the purpose of saving lives.

**4.1.2** In addition to routine training programs, airport ARFF services and all structural fire departments and community emergency services with jurisdictions adjacent to an airport or its traffic patterns are encouraged to frequently schedule and participate in multi-agency training sessions based on the material in this guide. The objective of these sessions should be to focus on achieving maximum unity, compatibility, and effectiveness at aircraft emergencies should they be on or off the airport. (*See Section 4.5.*)

**4.1.3** All ARFF personnel should participate in regular exercises involving simulated aircraft accidents throughout the year. Frequent command-level training for those persons assigned to major roles in the airport/community emergency plan is also essential. Command training can be presented in the form of workshop or tabletop exercises designed to develop effective emergency management techniques. Guidance for emergency plan exercises is provided in NFPA 424, *Guide for Airport/Community Emergency Planning*.

**4.1.4** Command authority at any accident site should be predetermined according to the jurisdictional responsibilities of the agencies involved and as designated in their airport/community mutual aid agreement.

### 4.2 Emergency Response Preplanning.

**4.2.1** All ARFF vehicles in use at the airport should be able to meet the provisions of NFPA 414, *Standard for Aircraft Rescue and Fire-Fighting Vehicles*, upon acceptance from the manufacturer and should be maintained in a manner to ensure such levels of performance. Special training should be provided to enhance the skills of all vehicle operators, as their performance is critical to successful vehicle utilization, particularly under unfavorable conditions. ARFF drivers should actually drive all service roads and be familiar with any gates.

**4.2.2\*** Operators assigned to each ARFF vehicle should make trial runs to all areas of the airport in all weather conditions during which flight operations take place. Particular emphasis should be placed on the ability to respond to the critical rescue and fire-fighting access area since this is where most accidents occur. These runs will demonstrate each vehicle's operational capability and the time required to reach each site. Since many aircraft accidents occur in the overrun areas of the runways, it is important to provide suitable routes for use by the vehicles to enable them to reach these areas. Bridges spanning gullies, streams, ditches, cattle grids, or other ground surface appurtenances should be capable of supporting at least 120 percent of the weight of the heaviest emergency vehicle.

**4.2.3** Where construction work of any kind is likely to affect the response capability or operational performance of the ARFF service, prior notification of the work should be provided so that amendments can

be made to operational procedures to overcome or minimize their effect. This is particularly important where work on airport water mains is likely to close down one or more fire hydrants.

**4.2.4** In order to provide multi-vehicle access to the accident site, service roads should be so constructed that one vehicle cannot block ingress or egress for other emergency vehicles. This can be accomplished by providing roads of sufficient width or suitable passing and turnaround areas. An access for service roads should also be strategically placed and maintained near the ends of runways, or key taxiways that will allow ARFF crews all weather access. Where gates are secured using locks, all airport gates should be capable of being opened using the same key. Where remotely controlled, the operation should be provided from each ARFF vehicle.

**4.2.5** Frangible gates or fence sections should be located at strategic locations to allow rapid access by ARFF vehicles to areas outside the airport boundary. Keys to gate locks should be carried on each authorized emergency vehicle, by airport security personnel and designated local emergency services.

**4.2.6** Grid maps should be provided for each airport and its environs. They should be ruled with numbered and lettered grids (*see Figure 4.2.6*) to permit rapid identification of any response area. The area covered by a grid map should be a distance of 8 km (5 mi) from the center of the airport. This can vary depending upon the type of terrain or location of the airport in relation to other emergency facilities. Map nomenclature should be compatible with that used by off-airport public safety authorities. Two or more maps might be required where the area exceeds a 8-km (5-mi) radius. One map should display medical facilities, heliports, and other features according to the airport/community emergency plan. Where more than one grid map is used, grid identifications should differ by color and scale to assist in their identification. Prominent local features, access routes, staging areas, and compass headings should be shown to facilitate locating accident and medical facility sites. Copies of grid maps should be prominently displayed at Air Traffic Control, the airport operations office, each airport and community fire station, all mutual aid services, and carried on all appropriate emergency vehicles.

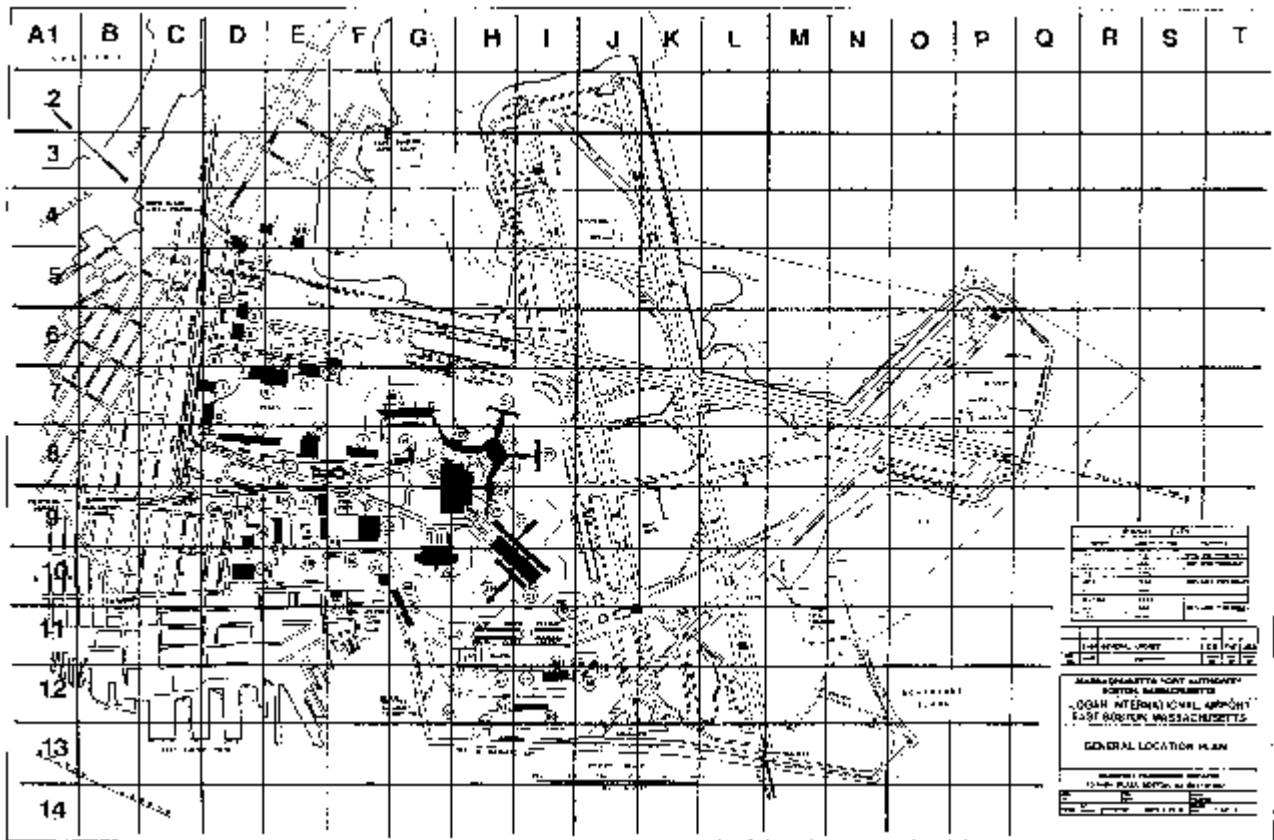

**FIGURE 4.2.6 Typical Airport Grid Map.**

**4.2.7** Backup systems should be provided in airport fire stations to allow for the rapid operation of vehicle bay doors, for the efficient reception/transmission of vital communications, and for the provision of emergency lighting.

**4.2.8** A communication system from the airport to community or regional emergency services should be provided. The reliability of the system should be tested daily.

**4.2.9** Any off-airport emergency services authorized to respond to an on-airport incident should pre-incident plan access to the various areas of the airport, particularly the designated staging areas. Personnel should also be trained in the special procedures to be followed once on the airport.

**4.2.10** Sufficient ARFF vehicles and equipment should be provided to meet the required level of protection as specified in NFPA 403, *Standard for Aircraft Rescue and Fire-Fighting Services at Airports*, for the airport during flight operations. When this protection level is reduced for any reason (i.e., off-airport response, mechanical breakdown, lack of qualified personnel, etc.), all incoming and departing aircraft should be notified of the change in ARFF capability.

**4.2.11** It is important that pre-incident planning includes response of additional pumping vehicles, ladder trucks, elevated platform vehicles, portable lighting equipment, hoisting and lifting equipment, medical supplies, and any other available specialized equipment or vehicle for which a requirement is anticipated. It is extremely important that the pre-incident plan also ensures the immediate availability of the special vehicles and equipment, provision for qualified driver-operators, and especially the availability of approving authority on an around-the-clock basis.



### 4.3 Airport Fire Fighter Basic Knowledge.

**4.3.1** To assure that airport fire fighters have a suitable degree of skill, basic training should be provided in accordance with NFPA 1003, *Standard for Airport Fire Fighter Professional Qualifications*.

**4.3.2** Comprehensive, continuous in-service training in accordance with NFPA 405, *Recommended Practice for the Recurring Proficiency Training of Aircraft Rescue and Fire-Fighting Services*, should be provided to maintain each fire fighter's proficiency. For further information on training subjects, see the references listed in Chapter 2 and Annex H.

**4.3.3** The complexity of modern aircraft and the variety of types in service make it difficult to train ARFF personnel in all the important design features of each model. However, they should become as familiar as possible with each type of aircraft that normally uses the airport. Particular emphasis should be placed on all of the following (*see also NFPA Aircraft Familiarization Charts Manual*):

- (1) Location and operation of normal and emergency exits, cargo doors, equipment, and galley access doors
- (2) Seating configurations
- (3) Type of fuel and location of fuel tanks
- (4) Location of ejection seats and armament (military aircraft)
- (5) Locations of batteries, hydraulic, and oxygen systems
- (6) Positions of break-in points on the aircraft
- (7) Location of rapidly activated standby generators or turbines
- (8) Fire access panels
- (9) Location of aircraft construction materials that are subject to be releasing hazardous/toxic substances while burning (i.e., carbon fibers, etc.)

**4.3.4** Airports are large commercial complexes that contain many potential life and fire hazards. These hazards vary relative to aircraft operations, time of day, weather conditions, construction, or a combination of these factors. It is, therefore, vital that ARFF personnel become extensively knowledgeable about the airport and any changes that occur that could adversely affect immediate response or the efficient performance of their rescue and fire-fighting responsibilities. Minimum requirements of knowledge should include all of the following:

- (1) Water supply locations (hydrants)
- (2) Runway identifications and locations
- (3) Taxiway identifications and locations
- (4) Airport lighting systems
- (5) Most effective response routes and alternatives
- (6) Fuel handling and storage areas
- (7) Key airport locations
- (8) Airport service roads

- (9) Gates and fences
- (10) Airport drainage systems

#### **4.4 Communications.**

**4.4.1** All airport emergency vehicles should be provided with multiple channel two-way radios operating on the airport's assigned ground control frequency and other airport emergency frequencies.

**4.4.2** It is desirable that airport ARFF vehicles be able to monitor or be in direct voice communications with an aircraft during an emergency situation. This procedure is especially important when airport control towers are not in operation.

**4.4.3** At an aircraft accident site, power megaphones can be valuable tools to coordinate flight deck crew/ARFF activities, direct evacuating aircraft occupants to safe locations, and so forth.

**4.4.4** Portable radios can be utilized at an accident site to communicate with the command post, airport emergency dispatcher, airport management, arriving back-up units, and so forth. Where personnel and vehicles from more than one agency will operate in mutual support, common radio frequencies should be available. If not, pre-incident planning procedures should be established so that portable radios can be exchanged, the use of messengers employed, or methods of relaying messages through the command post utilized. When portable radios are exchanged, consideration should be given to avoiding channel saturation and the maintenance of communication discipline.

**4.4.5** Experience from recent accidents has shown that the use of automated voice notification systems greatly facilitates emergency response/mutual aid notification.

**4.4.6** The use of cellular telephones in ambulances, in supervisory vehicles, and in command post vehicles can provide significant benefits in command and control functions.

#### **4.5 Mutual Aid Considerations.**

**4.5.1** As indicated previously, it is essential to have mutual fire-fighting assistance agreements with community and regional, off-airport fire departments. Successful rescue operations and handling of aircraft accident fires both on and off the airport depends on pre-incident planning the effective use of mutual aid (*see also Annex F*). The following considerations are significant:

- (1) Special attention should be given to ensuring compatibility in equipment designs (i.e., fire hose threads, communications equipment, etc.) and to fire control operational techniques.
- (2) It is important to familiarize structural fire department personnel with the special problems relating to aircraft rescue and fire fighting including methods of access to aircraft operating areas and how to operate vehicles while on the airport.

**4.5.2** Airport orientation visits should be arranged by fire departments bordering airports for consultations with the airport fire department, airlines, the military services, and others as appropriate. Their training in airport/aircraft familiarization should include those items listed in 4.3.3 and 4.3.4, diagrams in the NFPA *Aircraft Familiarization Charts Manual*, and grid maps of the airport and surrounding area.

**4.5.3** Structural fire-fighting vehicles normally carry small amounts of water as compared to the amounts usually carried on major airport ARFF vehicles. However, they can be useful in relaying water from hydrants, reservoirs, or other sources to maintain ARFF vehicle supplies.

**4.5.4** Structural fire fighters can be utilized to provide assistance to airport ARFF personnel by handling hose

lines, operating tools and equipment, assisting in rescue operations, and protecting exposures.

## Chapter 5 Flight Deck Crew and ARFF Personnel Responsibilities

### 5.1 Areas of Responsibility.

**5.1.1** The flight deck crew, flight attendants, and ARFF personnel should have the skills to deal with aircraft emergencies and should be familiar with each others' responsibilities to ensure that all their efforts are clearly directed toward the common goals of life and fire safety.

**5.1.2** The prime mission of all concerned is the safety of all persons aboard the aircraft and any others involved in the emergency. Duties and responsibilities can generally be defined as follows:

- (1) Flight deck crews hold the primary responsibility for the aircraft and for the safety of its occupants. The final decision to evacuate an aircraft and the manner in which the evacuation is carried out are made by the flight deck crew provided they are able to function in the normal manner at the time.
- (2) Flight deck crews and flight attendants share responsibility for the aircraft and for the safety of its occupants. The final decision to evacuate an aircraft and the manner in which the evacuation is carried out are made by the flight deck crews and flight attendants provided they are able to function in the normal manner at the time.
- (3) It is the duty of responding ARFF personnel to create conditions in which survival is possible and evacuation or rescue can be conducted. As visibility from within an aircraft is limited, any external features or situations likely to be of significance in the evacuation process should be communicated to the aircraft's crew. Should it become apparent that the crew's incapacity precludes the initiation of evacuation, the incident commander of the ARFF personnel should take the initiative.

**5.1.3** To prevent injury when an emergency aircraft evacuation takes place, consideration should be given to assist occupants using the aircraft slides.

### 5.2 Communications.

**5.2.1** Effective communications between flight deck crew and ARFF personnel is very important during emergencies. Contact should be established at the earliest possible time between persons in charge of each group. Exchange of pertinent information can assist in developing better decisions and plans of action. Several methods of direct communication are generally available such as aircraft interphone, tower relay, direct radio communication via approved frequency or visual signals.

**5.2.2** Where aircraft engines are operating, radio communications near the aircraft can be very difficult. Most aircraft are equipped with intercom systems and provided with plug-in jacks normally located under the forward portion of the aircraft near the nose gear. ARFF personnel should be aware of this means of communication and carry the necessary headset and microphone to plug into these facilities. Even with the engines operating, direct communications with the flight deck crew can be established by use of this system as long as the power is on.

**5.2.3** Where a more direct means of communication cannot be established, the incident commander of the responding ARFF personnel should go to the left side of the aircraft nose and establish direct eye contact and voice communications with the captain of the flight deck crew. If engine noise is a problem and a power megaphone is not available, it might be necessary to resort to hand signals to communicate. Figure 5.2.3 depicts standard international ground to aircraft hand signals that should be used by ARFF personnel to

communicate with the captain during emergencies. These hand signals are established for emergency communication between the ARFF Incident Commander/ARFF Firefighters and the Cockpit and/or Cabin Crews of the Incident Aircraft. ARFF Emergency Hand Signals should be given from the left front side of the aircraft for the cockpit crew. (Note: In order to communicate more effectively with the cabin crew, Emergency Hand Signals may be given by ARFF Firefighters from other positions.)

**Recommend Evacuation** — Evacuation recommended based on ARFF Incident Commander's assessment of external situation.



Arm extended from body, and held horizontal with hand upraised at eye level. Execute beckoning arm motion angled backward. Non-beckoning arm held against body.

Night — same with wands.

**Recommend Stop** — Recommend evacuation in progress be halted. Stop aircraft movement or other activity in progress.



Arms in front of head, crossed at wrists

Night — same with wands.

**Emergency Contained** — No outside evidence of dangerous condition or "all clear."



Arms extended outward and down at a 45-degree angle. Arms moved inward below waistline simultaneously until wrists crossed, then extended outward to starting position (umpire's "safe" signal).

Night — same with wands.

**FIGURE 5.2.3 Standard International Ground to Aircraft Signals. (Photos courtesy of the Air Line Pilots Association)**

**5.2.4** If aircraft engines are operating, ARFF personnel should use extreme caution when approaching an aircraft for communications purposes as described in 5.2.2 and 5.2.3. The aircraft should be approached only from the front and well ahead of the nose and, if possible, in full view of the captain. Vehicle and hand-held lights should be used in periods of darkness and poor visibility. See Table 5.2.4 for light gun signals.

**Pilots Association)**

**5.2.4** If aircraft engines are operating, ARFF personnel should use extreme caution when approaching an aircraft for communications purposes as described in 5.2.2 and 5.2.3. The aircraft should be approached only from the front and well ahead of the nose and, if possible, in full view of the captain. Vehicle and hand-held lights should be used in periods of darkness and poor visibility. See Table 5.2.4 for light gun signals.

**Table 5.2.4 Standard Air Traffic Control Tower Light Gun Signals**

<b>Color and Type of Signal</b>	<b>Movement of Vehicles, Equipment, and Personnel</b>	<b>Meaning</b>	
		<b>Aircraft on the Ground</b>	<b>Aircraft in Flight</b>
Steady green	Cleared to cross, proceed, or go	Cleared for takeoff	Cleared to land
Flashing green	Not applicable	Cleared for taxi	Return for landing (to be followed by steady green at the proper time)
Steady red	STOP	STOP	Give way to other aircraft and continue circling
Flashing red	Clear the taxiway/runway	Return to starting point on airport	Airport unsafe, do not land
Flashing white	Return to starting point on airport	Return to starting point on airport	Not applicable
Alternating red and green	Exercise extreme caution	Exercise extreme caution	Exercise extreme caution

## Chapter 6 Emergency Response

### 6.1 General.

**6.1.1** The survivable atmosphere inside an aircraft fuselage involved in an exterior fuel fire is limited to approximately 3 minutes if the integrity of the airframe is maintained during the impact. This time could be substantially reduced if the fuselage is fractured. When the aluminum skin is directly exposed to flame, burnthrough will occur within 60 seconds or less while the windows and insulation may withstand penetration for up to 3 minutes. Because of this serious life hazard to occupants, rapid fire control is critical. Therefore, whenever flight operations are in progress, ARFF vehicles and personnel should be so located that optimum response and fire control can be achieved within this time frame.

**6.1.2** At many airports portions of the critical rescue and fire-fighting access areas might be outside the airport boundaries. There also can be obstructions created by natural features, highways, or railroad right-of-ways that would delay or preclude access by ARFF vehicles. Consideration should be given in these instances to providing specialized vehicles where conventional vehicles can be restricted due to unusual terrain characteristics. Any delay in response time is critical, and mutual assistance agreements with off-airport agencies should be established to provide optimum response in problem areas. (See Figure 6.1.2.)

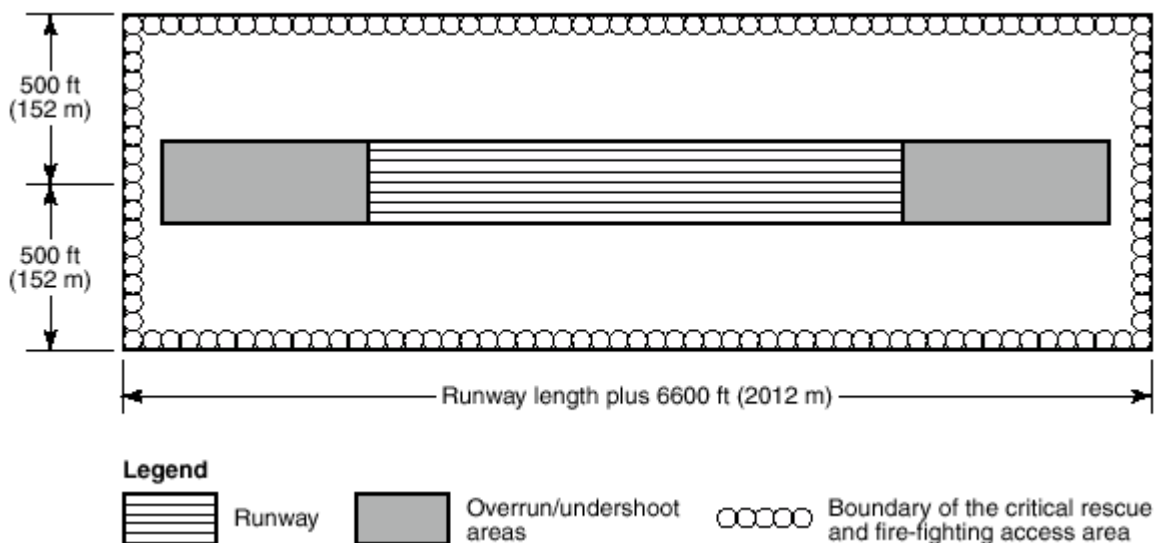

**FIGURE 6.1.2 Critical Rescue and Fire-Fighting Access Area.**

**6.1.3** To obtain the desired response, pre-incident planning should include a wide range of factors such as adequate alarm systems, fire station locations (or prepositioning of resources), vehicle operator training, airport familiarization, and staging areas for outside assistance.

**6.1.4** Fire stations should be located so that rapid direct access to the operational runway(s) utilizing maximum acceleration rate and top speed of the vehicles is utilized to enable them to reach any point on the runway(s). The access road to the runway(s) should be as direct as possible.

**6.1.5** All-weather access routes to the critical rescue and fire-fighting access area suitable for ARFF vehicles should be designated and should be maintained in usable condition while flight operations are in progress.

**6.1.6** To minimize response times, operational procedures should exist through which Air Traffic Control (ATC) would stop or divert all aircraft and nonessential traffic that would conflict with responding emergency vehicles.

**6.1.7** Airports updating their master plan for airport development should consider the location of obstructions in the critical rescue and fire-fighting access area such as ditches, mounds, vegetation, or nonfrangible structures that could cause extensive damage to any overrunning aircraft or obstruct the positioning of emergency vehicles.

## **6.2 Low Visibility Operations.**

**6.2.1** New and improved techniques for instrument takeoff and landing permit flight operations to continue under adverse weather conditions. Low visibility operations criteria vary from one airport to another depending upon the type of instrument landing system available, the level of natural and manmade obstructions in the surrounding terrain, the type of runway lighting, and the capability of the onboard instrument systems of the aircraft using the airport. Such operational minimums can vary from 5 km (3 mi) visibility to 100 m (300 ft) for landings and with similar restrictions for takeoff. ARFF personnel should ascertain operational restriction levels from the local Air Traffic Control (ATC) agency in order to establish response capability under minimum visibility conditions.

**6.2.2\*** Although aircraft operational navigational weather minimums might not be in effect, fully staffed Local Standby Alert procedures should be initiated when flight operations are in progress and surface visibility and conditions are less than 800 m (½ mi). Whenever operational/environmental conditions exist having the potential to impede a timely ARFF response, an assessment should be made regarding ARFF personnel and equipment or repositioning of resources or both. (*See also Section 10.2.*)

**6.2.3** Standbys during low visibility operations and adverse weather conditions should have at least one major ARFF vehicle located at a distance no closer than the taxiway hold line adjacent to the midpoint of the active runway unless the fire station(s) location(s) permits effective response times. (*See Figure 6.2.3.*) When on standby, vehicle operators should keep engines running and such lights operating as to effectively mark the position of the vehicle. If the vehicle is equipped with a FLIR system, it should be fully operational with an in-cab display.

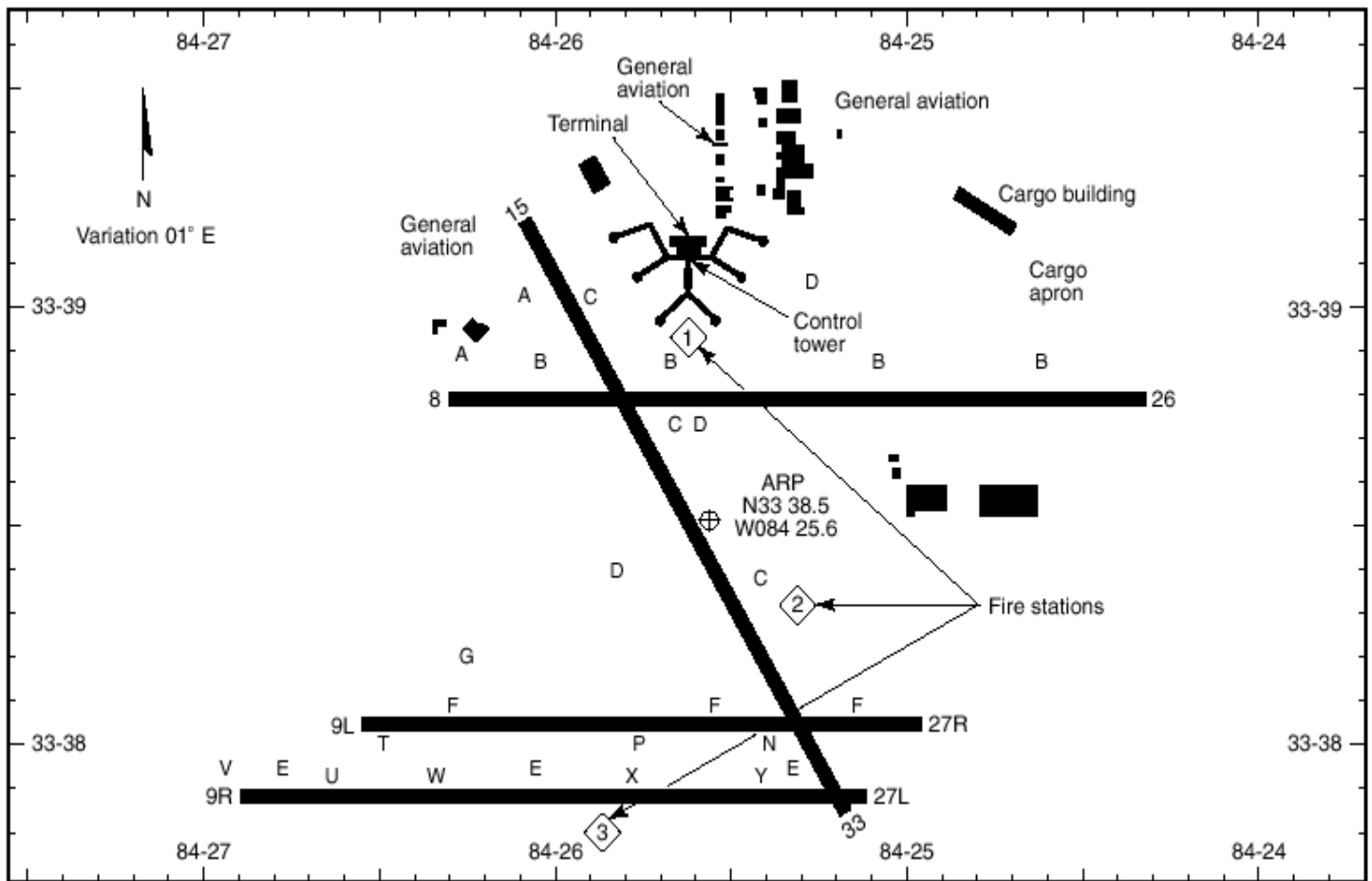

**FIGURE 6.2.3 Example of Airport Fire Station Locations.**

**6.2.4** ARFF personnel assigned to any standby should monitor all applicable radio frequencies.

**6.2.5** Air Traffic Control (ATC) should be made aware of the exact location of the ARFF vehicles assigned to standby duty. Where available, surface navigational aids, such as ground radar (ASDE), should be fully utilized through coordination between ARFF personnel and the control tower.

**6.2.6** ARFF vehicles can be equipped with an infrared vision system to assist the crew of the vehicles to locate and respond to emergencies in low visibility conditions.

**6.2.7** Positioning equipment can be installed on ARFF vehicles to enable the drivers to know their position on the airport at all times.

### **6.3 Considerations for Airports Adjacent to Water.**

**6.3.1** Where airports are situated adjacent to large bodies of water such as rivers or lakes, or where they are located on coastlines, provisions for the availability of specialized water rescue vessels, or helicopters, or both, and equipment should be in place.

**6.3.2** Inclined ramps or docking facilities should be considered by airports located adjacent to large bodies of water to allow rapid response to aircraft accidents. Launch ramps should be located adjacent to the overrun areas of the critical rescue and fire-fighting areas. Where appropriate, ARFF crews should have navigational maps available.



**6.3.3** For rescue purposes, the vessel(s) should be equipped with flotation platforms, rafts, and/or personal flotation devices, or a combination of these for the maximum number of occupants carried on the largest aircraft regularly scheduled into the airport.

**6.3.4** Rescue vessels should be capable of rapid response to the accident site.

## Chapter 7 Factors Common to Airport Emergencies

### 7.1 General.

**7.1.1** The primary hazard associated with aircraft accidents is that liquid fuels are likely to be released and ignited during the accident sequence. A secondary hazard is that fuels released but not ignited could subsequently be ignited prior to or during the egress of occupants. In addition, fires involving combustible materials such as interior furnishings, stored goods, and aircraft system components can occur. Further complications could result if the aircraft comes to rest in such an attitude that forcible fuselage entry or shoring for stabilization might be required.

**7.1.2** During all aircraft emergencies, all persons not directly involved in the ARFF phase of the incident, including the news media, should be required to stay well clear of the site until evacuation, occupant care, full fire control, and site safety security are completed. Responsibility for site security should be pre-assigned to the law enforcement agency of primary jurisdiction and could be augmented by other law enforcement agencies, guards, military, and volunteers as needed.

**7.1.3** The various emergencies that can be anticipated include emergencies involving aircraft in flight (found in Section 7.2), as well as emergencies that occur on the ground. The emergency declarations associated with pre-flight and post-flight aircraft operations, maintenance, and servicing are generally referred to as aircraft ground emergencies. Information on aircraft ground emergencies can be found in Chapter 12 of this document.

### 7.2 Types of Alerts.

**7.2.1** The terms used to describe categories of emergency alerts are not standardized. The Federal Aviation Administration (FAA) terms, Local Standby Alert, Full Emergency Alert, and Aircraft Accident Alert, and the International Civil Aviation Organization (ICAO) terms, “Local Standby,” “Full Emergency,” and “Aircraft Accident,” are equivalent. Individual airports might have adopted their own nomenclature for Local Standby Alert, Full Emergency Alert, or Aircraft Accident Alert. This must be coordinated with the appropriate authority.

**7.2.2 Local Standby Alert — “Local Standby.”** When an aircraft has, or is suspected to have, an operational defect, the incident should be considered a Local Standby Alert. The defect should not normally cause serious difficulty for the aircraft to achieve a safe landing.

**7.2.2.1** Under Local Standby Alert conditions, at least one ARFF vehicle should be staffed and positioned to permit immediate use in the event of an accident. If the time and conditions permit, ARFF personnel should be advised of the following:

- (1) Aircraft type
- (2) Number of passengers and crew
- (3) Amount of fuel remaining

- (4) Nature of the emergency
- (5) Type, amount, and location of dangerous goods aboard
- (6) Number and location of nonambulatory passengers on board, if any

All other in-service ARFF vehicles should remain available for immediate response.

**7.2.2.2** A Local Standby Alert should also be initiated when an aeromedical evacuation aircraft with patients aboard is approaching or departing the airport. The authority having jurisdiction should establish protocols for handling of aeromedical evacuation aircraft with patients on board.

**7.2.2.3** Whenever operational/environmental conditions exist having the potential to impede a timely ARFF response, an assessment should be made regarding ARFF personnel and equipment or repositioning of resources or both.

**7.2.2.4** Operational policies should be in effect for aircraft movements not normally encountered by the airport.

**7.2.3 Full Emergency Alert — “Full Emergency.”** When an aircraft has, or is suspected to have, an operational defect that affects normal flight operations to the extent that there is danger of an accident, the incident should be considered to be a Full Emergency Alert, or a “Full Emergency.”

**7.2.3.1** When a Full Emergency Alert emergency is declared, ARFF personnel should be provided with detailed information that allows preparation for likely contingencies. A full response should be made with the ARFF vehicles staffed and in position with engines running and all emergency lights operating so that the fastest response to the accident/incident site can be accomplished.

**7.2.3.2** It is important that appropriate radio frequencies be continuously monitored by ARFF personnel. One or more major ARFF vehicles should be able to initiate fire suppression within the briefest period of time after the aircraft comes to rest. Standby positions for ARFF vehicles should be established for the type of emergency and aircraft involved.

**7.2.3.3** ARFF personnel should be informed of any changes in a distressed aircraft’s emergency situation.

**7.2.4 Aircraft Accident Alert — “Aircraft Accident.”** This alert denotes that an aircraft accident has occurred on, or in the vicinity of, the airport.

**7.2.4.1** Regardless of the source of an Aircraft Accident Alert alarm, full ARFF response should be put into effect. When possible, all known pertinent information should be relayed via radio by Air Traffic Control (ATC) to responding units and include, as accurately as possible, the accident location using landmarks and grid map coordinates.

**7.2.4.2** When an accurate accident location is not available, ARFF personnel should anticipate the worst situation and stand by until signs of an accident are evident or better information is received. Mutual aid assistance should be initiated in accordance with the airport/community emergency plan. (*See also NFPA 424, Guide for Airport/Community Emergency Planning, and ICAO Airport Services Manual, Part 7.*) During all Aircraft Accident Alerts, ARFF crews should always assume there are survivors.

### **7.3 Vehicle Response to Aircraft Accidents.**

**7.3.1** ARFF vehicles should approach any aircraft accident by the route that provides the quickest response time. This might not necessarily be the shortest distance to the scene. Traversing through unimproved areas can take longer than traveling a greater distance on paved surfaces such as taxiways, ramps, and roads. Total

response time is vital. Preferred routes, especially those within the critical rescue and fire-fighting access area, should be preselected. Practice response runs should be made under both ideal and inclement weather conditions.

**7.3.2** In some cases, runways and taxiways are blocked by aircraft awaiting taxi clearance or takeoff. Vehicle operators should be aware of alternate routes that can be used so as not to delay response.

**7.3.3** The load-bearing characteristics of the airport soil structure under various weather conditions should be known, and vehicle operators should be trained to deal with off-road driving conditions. When responding in rough terrain conditions, ARFF responders should consider alternate routes.

**7.3.4** When nearing the accident scene, vehicle operators should be alert to avoid all persons in the area, especially those who might be injured, unconscious, or wandering about in a dazed condition. In darkness, periods of low visibility, or when operating in areas of tall vegetation, extra caution and effective use of lighting equipment, audible warnings, FLIR systems, or a combination of these might be needed.

## **7.4 Positioning of ARFF Vehicles.**

**7.4.1** Information from the flight deck crew relative to the nature of the emergency will assist the ARFF personnel to better determine the most advantageous positioning of the vehicles upon arrival at the scene of an aircraft emergency.

**7.4.2** Piston-type engine aircraft provide different options for initial positioning of ARFF vehicles than do turbojet aircraft that have swept-back wings and produce a jet blast hazard. ARFF personnel should therefore consider an approach from the nose of jet aircraft. However, this should not become a standard procedure as wind conditions, terrain, type of aircraft, location of engines, cabin configurations, and other factors can dictate the optimum approach in a given circumstance.

**7.4.3** Vehicle position should never obstruct aircraft evacuation or interfere with the deployment of evacuation slides. (*See also Chapter 9.*)

**7.4.4** Propellers turning on turboprop or piston-type engine aircraft present a hazard to evacuees and ARFF personnel. Turbojet engines present different problems. For example, the areas directly ahead of and for a considerable distance behind the engines should be avoided because of the intake and jet blast hazards. Turbojet engines will rotate for a considerable time after they have been shut down. (*See Figure 7.5.6.*)

**7.4.5** When combination cargo/passenger (COMBI) aircraft have declared an emergency, ARFF personnel should be informed of cabin configurations prior to the landing. Since some cargo areas extend over the wings, the overwing exits could be unavailable for use as emergency exits.

**7.4.6** The mission of the first-arriving ARFF vehicle and crew is to assist in evacuation of occupants, prevent the outbreak or spread of fire, and perform any rescue operations required. The vehicle should be positioned to protect the principal evacuation route being used by the occupants. When it is obvious that the occupants are evacuating safely without assistance and the fire or threat of fire is controlled, later-arriving vehicles and crews can be strategically positioned and tasks assigned. Caution must be exercised to avoid placing evacuees, ARFF personnel, or vehicles in locations that could become hazardous in the event of a sudden extension of fire.

## **7.5 Hazards to ARFF Personnel.**

**7.5.1** ARFF personnel should always remain alert to the possibility of ignition of flammable vapors that are always present in the area of damaged aircraft. Elimination of ignition sources and the maintenance of an unbroken foam blanket is the best procedure in preventing ignition of these vapors.

**7.5.2** All ARFF personnel should be provided with and be required to wear proper protective clothing and equipment. Personnel should be fully trained in the use limitations and value of such protective clothing and equipment by utilizing them in frequent fire-fighting drills.

**7.5.3** Aircraft structures damaged by fire or impact forces are often very unstable and subject to collapse or rollover. If these conditions are suspected to exist, precautions in the form of blocking or shoring should take place as soon as practicable to ensure the safety of ARFF personnel working in the area.

**7.5.4** If dangerous goods are believed to be involved in an emergency, procedures should be carried out as prescribed in the U.S. Department of Transportation *Emergency Response Guidebook*. This also includes incidents involving agricultural spraying aircraft and the associated pesticides.

**7.5.5** An undercarriage fire creates a potential for aircraft collapse or explosive disintegration of affected components from wheel assemblies. Personnel should not cross the possible fragmentation area, which covers an angle of 45 degrees from the side of the wheel assemblies to a distance of at least 90 m (289 ft). (See Figure 7.5.5.)

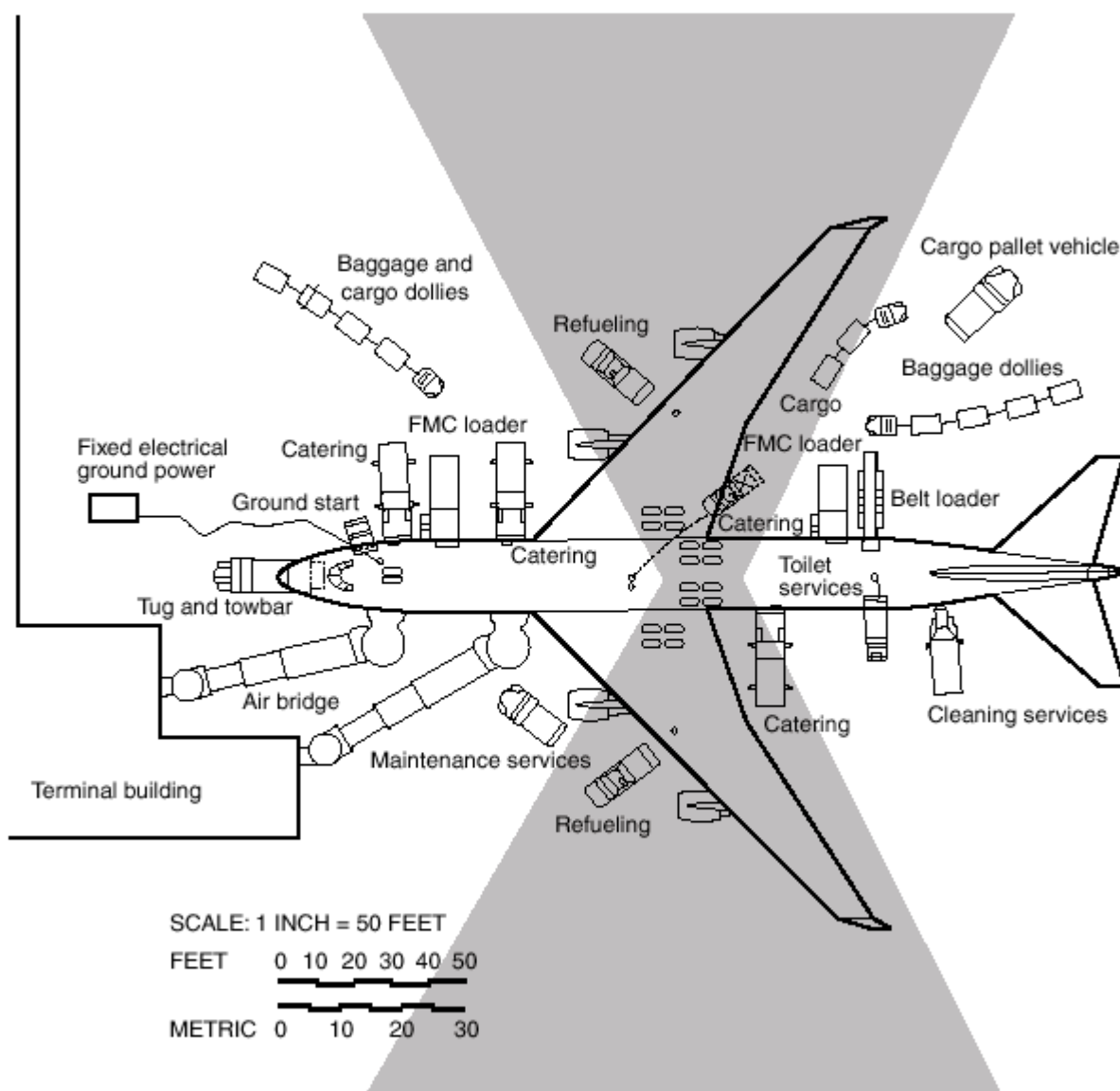

## FIGURE 7.5.5 Wheel Fragmentation Area.

**7.5.6** ARFF personnel should stay well clear of an operating jet engine to avoid intake and exhaust hazards. (See Figure 7.5.6.) Before ARFF personnel approach an aircraft, the incident commander should request the captain to shut down appropriate engine(s) to ensure that there is a safe area of work.

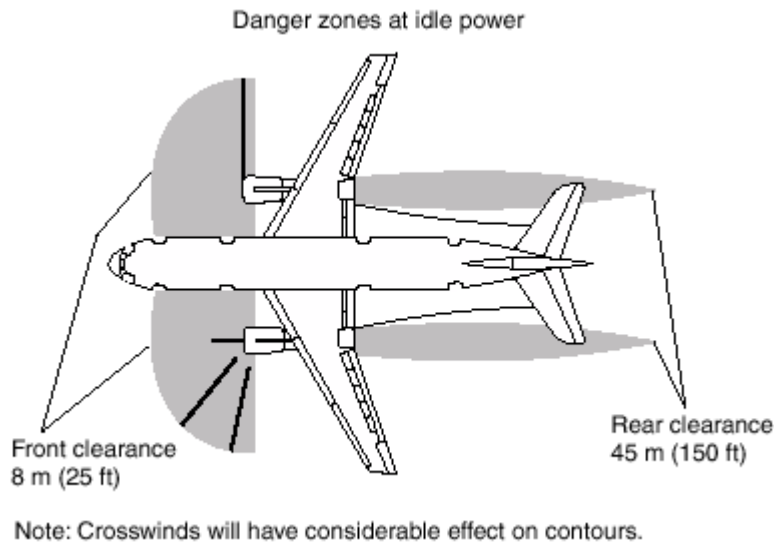

**FIGURE 7.5.6 Engine Run Danger Areas.**

**7.5.7** The propellers of piston-type engine aircraft should never be moved when at rest as any movement could, under certain conditions, restart the engine. ARFF crews should be aware of the various prop arcs of aircraft and make it standard operating procedure to never pass under or through a prop arc.

**7.5.8** Some modern jet aircraft are equipped with Ram Air Turbines (RAT) or Air Driven Generators (ADG) designed to provide back-up electrical and hydraulic power in the event of in-flight failures of primary systems. These devices are often designed to deploy from flush fuselage or engine-mounted storages, and some can deploy with considerable force. ARFF personnel should become aware of aircraft employing these systems and their locations. Serious injury could result should the RAT accidentally deploy and strike a person during emergency operations. (See Figure 7.5.8 where a deployed Ram Air Turbine on a Lockheed 1011 aircraft is shown. It is located at the center underside of the fuselage slightly forward of a point directly in line with the main landing gears.)

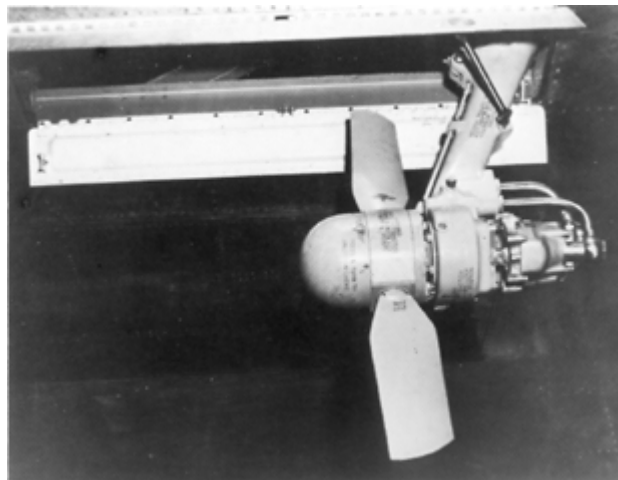

### FIGURE 7.5.8 Ram Air Turbine.

**7.5.9** On Boeing 767, if the ground spoilers are deployed and an overwing plug is opened, they will rapidly retract down. This is done so that exiting passengers will not be hampered in evacuation. The slide also deploys from the side of the fuselage.

**7.5.10** When approaching helicopters and the pilot is conscious, approach in full view and follow the pilot's instruction (pilot normally sits in the right-hand seat); avoid blind areas where the pilot cannot be seen. Under crash conditions where the pilot is incapacitated and the rotors are still operating it may be advisable to approach in a crouching position, from the opposite side to the tail stabilizing rotor at a position slightly to the rear of the main rotor head, remaining as close to the fuselage as possible as the main rotors are designed to rise clear above the tail (remember that main rotors tend to lower at the front of the helicopter). [See Figure 7.5.10(a) and Figure 7.5.10(b).]

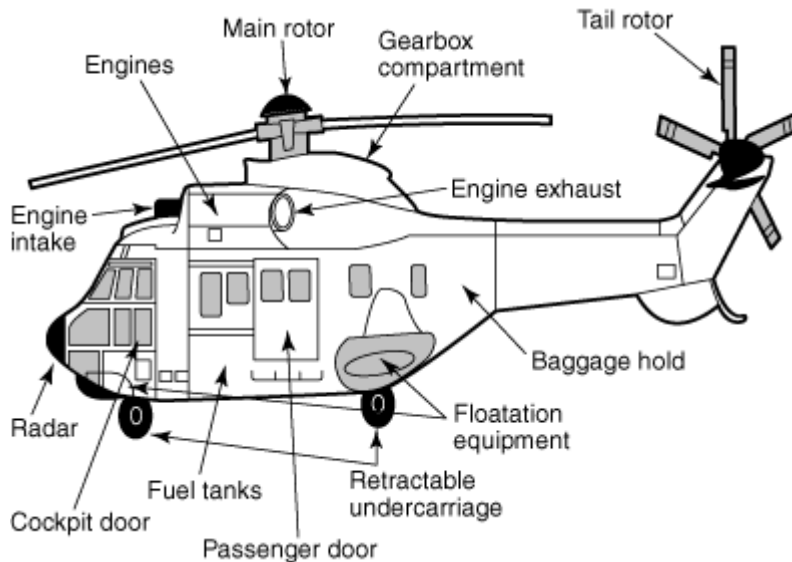

**FIGURE 7.5.10(a) Helicopter Showing Main Rotor Lower in Front.**

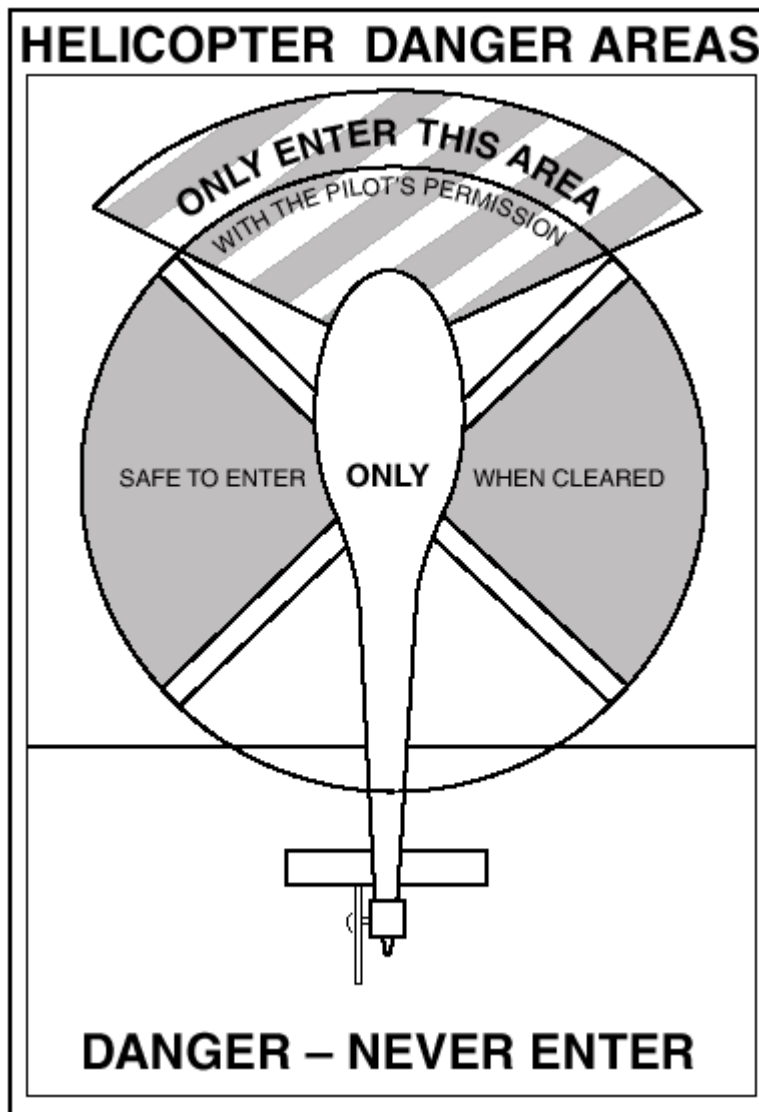

**FIGURE 7.5.10(b) Helicopter Danger Areas.**

**7.5.11** Composite materials used in aircraft construction can, when involved in a crash or fire situation, present the fire fighter with the following problems:

- (1) Emission of toxic gases on the decomposition of resins and bonding agents.
- (2) Airborne sharp particles of composite materials that can be ingested into the respiratory system and cause skin injuries and traumatic dermatitis.
- (3) In post-fire conditions they are capable of absorbing all of the products of a post-crash fire, potentially acting as a carrier, if fibers enter the body by skin injection or inhalation.

**7.5.11.1** A size-up (risk assessment) in respect to whether or not composite materials are involved should be undertaken, and the appropriate level of personnel protection for site management established. Factors to be considered should include the following:

- (1) Are composite materials, carbon, aramid, boron, fiberglass, or other synthetics involved?
- (2) The scale of involvement.

- (3) Are the composite material components in the internal airframe structure, for example, flooring, seating (internal containment if fuselage is intact), or external airframe structure, for example, skin panel control surfaces, rotor blades, and so forth, free to atmosphere?
- (4) The prevailing wind and weather conditions.
- (5) Composite material fibers cannot normally be detected by the naked eye.
- (6) Is there a fire or immediate risk of fire? ARFF vehicles should be positioned on the upwind side whenever possible. This must be taken into consideration when dealing with wheel assembly fires in the initial fire-fighting attack. Once the smoke plume has been controlled, the traditional fore and aft ARFF vehicle deployment can be implemented. Composite material characteristics relative to heat are as follows:
  - (a) Carbon fiber gives off cyanide gas at 150°C (328°F).
  - (b) Carbon fiber supports a flame at 195°C (409°F).
  - (c) Delamination occurs between 250°C and 300°C (508°F and 598°F).
- (7) The size, type, age, and contents of the aircraft. (Be aware of retrofitted structures and components on aircraft.)
- (8) A minimum distance of 100 m (321 ft) from the main fuselage and 30 m (96 ft) from debris, whichever is the greater, should be considered contaminated initially and become the boundary in establishing a restricted area. Personnel should, whenever tactically possible, remain upwind and uphill on the crash scene although this should not impair the effective operational deployment of ARFF vehicles, equipment, or personnel.
- (9) If crew and passengers self-evacuate an aircraft, assembly and coaching points must be upwind and outside of the restricted area (inner cordon).
- (10) Airborne fibers are highly conductive and can seriously damage electrical installations.
- (11) All aircraft and buildings downwind must be warned that there may be fibers in the atmosphere. It is to be advised that ventilation systems drawing air into buildings are closed, as this will minimize the risk of the polluted atmosphere being drawn into the interior of the building.
- (12) All foot traffic through the area must be curtailed.
- (13) Motorized traffic in the area must be kept to a minimum.
- (14) Helicopters must not be allowed over the affected area, as this could disturb the foam blanket and agitate the fibers by the downdraft it creates.
- (15) Any machinery or electrical equipment likely to be affected by smoke in any composite material related to the incident should not be used until it has been checked. Where smoke has been involved, a sticky lacquer-type residue is left, which can seriously impair moving parts in machinery.
- (16) Vehicle marshaling areas and subsequent triage area should be established upwind and in accordance with established procedures.
- (17) Accident sites may involve large numbers of people, many of whom may go to the scene unnecessarily if not controlled. Clear command structures are essential for overall effectiveness.
- (18) Limiting the spread of exposure of composite materials.



(19) Limiting the exposure of personnel and valuable equipment to composite materials.

**7.5.11.2** In post-fire conditions when composite materials such as carbon, aramid, boron, fiberglass, and other synthetics are involved, the fibers may initially be suppressed within the accident site by the application of aspirated foam, or fine water spray or by covering the immediate wreckage with salvage sheets which will assist in the control of airborne fibers materials. When resources are available the above can be achieved by the application of water-based suppressants or mixtures similar to a domestic based floor wax.

**7.5.11.3** Control of access and egress from the scene is essential for successful decontamination. ARFF personnel should undergo formal decontamination based on likely hazards and levels of exposure.

## Chapter 8 Aircraft Construction and Materials

### 8.1 Aircraft Construction.

**8.1.1** It is fundamental that ARFF personnel have a working knowledge of named parts and construction of an aircraft to ensure commonality in terms used, and recognition of potential difficulties and hazards when gaining access or extricating casualties. Aircraft are manufactured in many sizes. However, the common terms used in respect to identification of structural features are identified in Figure 8.1.1.

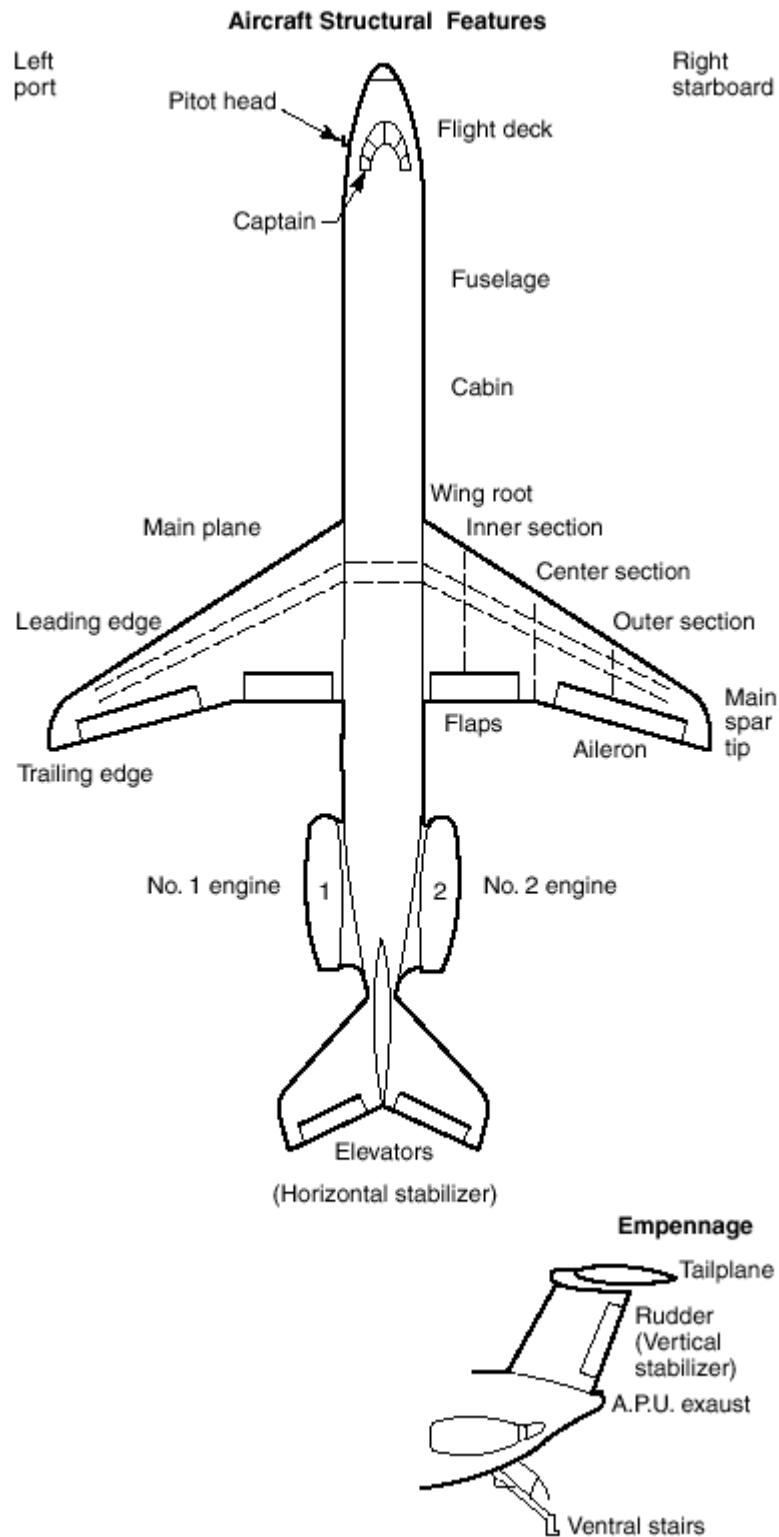

**FIGURE 8.1.1 Nomenclature for Aircraft Structural Features.**

**8.1.2** The structure of the fuselage consists of the following components:

- (1) The tapering shape of the fuselage is formed by a series of vertical frames (formers) placed transversely from nose to tail.
- (2) Metal struts (stringers) run horizontally along the length of the fuselage positioned around the

circumference of the formers.

- (3) The cabin floor is supported by horizontal weight bearing struts (longerons).
- (4) The rigidity of the airframe is achieved by a skin (stressed skin) which is riveted or bonded to the formers and stringers. (See Figure 8.1.2.)

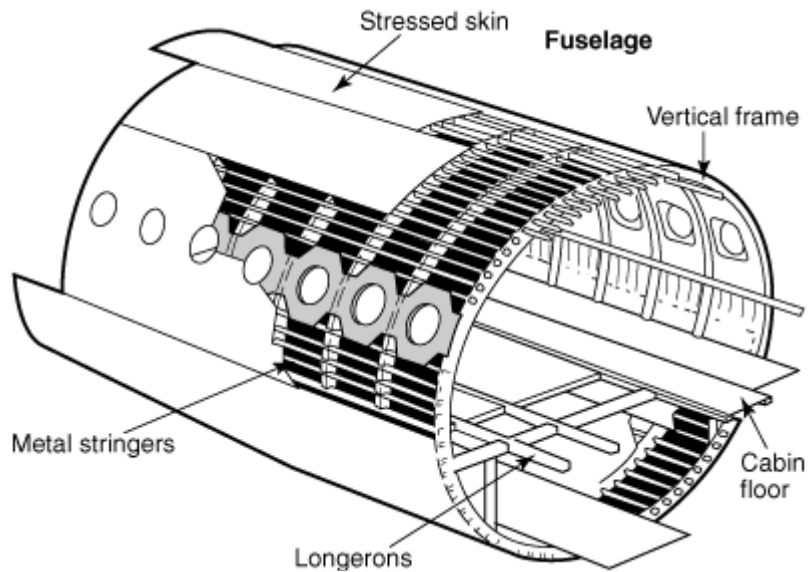

**FIGURE 8.1.2 Fuselage Components.**

**8.1.3** The structure of the wings (mainplane) consists of tapering spars (main and secondary spars), which can either run from the center section of the fuselage or from wing tip to wing tip. The number of spars depends on the wing design. Struts (ribs) are placed at right angles to the spars to form a profile of the wing design. Struts (stringers) run across the ribs on which a stressed skin is riveted or bonded. See Figure 8.1.3.

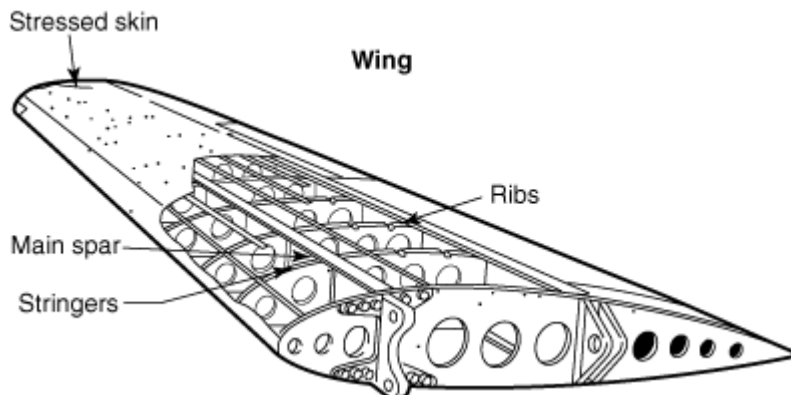

**FIGURE 8.1.3 Wing Components.**

**8.1.4** The undercarriage normally consists of a nose wheel and two groups of wheels (or more) situated behind the center of gravity beneath the aircraft. The landing gear incorporates a mechanism to raise and lower the undercarriage. A shock absorbing unit (oleo leg), wheels, and braking units are attached to the base of the oleo leg and supporting hydraulic pipe work. It is normal practice for wheels to incorporate a fusible plug which deflates the tire when excessive tire pressures develop. Hazards associated with the undercarriage are burst tires, hot brakes, ruptured hydraulic piping, and seals contained in the oleo leg rupturing causing the oleo to drop. Note that braking units are not normally situated on the nose wheel.

**8.1.5** The construction of the airframe of a helicopter is similar to the fuselage of a fixed wing aircraft. However, a helicopter is not stressed to carry a mainplane. The cabin is not pressurized for high altitude. Undercarriage assemblies are comparatively small, and in some cases not retractable, which means that structural components are smaller and lighter.

## **8.2 Aircraft Materials.**

**8.2.1** ARFF personnel should become familiar with aircraft construction materials. Most of these materials have a low resistance to flame exposure, and their behavior under fire conditions should be understood. They have high resistance to cutting or other forcible entry methods that can sometimes be difficult and time consuming and can virtually impede successful rescue and fire-fighting operations.

**8.2.2** Much of a modern aircraft structure is aluminum alloy. It is approximately 50 percent lighter than steel, and its normal appearance is light gray or a silvery surface when polished. It is used as sheets for aircraft skin surfaces, as channels for framework, and as plates and castings for bulkheads and fittings. This metal will not contribute to a fire to any significant degree. However, it will melt under the high temperature conditions found in aircraft fires. As a rule, aluminum will buckle and distort at 400°C (778°F) and decompose depending on thickness at 600°C (1138°F).

**8.2.3** Magnesium alloys are used for wheels, engine mounts, brackets, crankcase sections, cover plates, and other engine parts. The appearance of this metal is silvery-white or grayish, and it is about two-thirds the weight of aluminum. While it is not easily ignited, when it is ignited it burns at 900°C (1678°F) to 1000°C (1858°F) violently and cannot be easily extinguished. It thus presents a serious reignition source. Sparks developed when the metal comes in contact with paved surfaces, as might occur in a wheels-up landing, have the capability of igniting flammable vapors.

**8.2.3.1** Where special extinguishing agents are not available for magnesium fires, water in coarse heavy streams might provide a suitable alternative fire control method. At first, such streams will result in localized intensification of flame and considerable sparking and showering of burning magnesium. Isolated burning pieces of magnesium should be removed from flammable vapor areas.

**8.2.4** Steel in various forms, including stainless steel, is used in aircraft engine parts, around engine nacelles, engine fire walls, flap gear, and tubing. The metal presents no fire hazard, nor does it contribute to a fire except that it can create friction sparks when in contact with hard surfaces during a wheels-up landing. The sparks have sufficient energy to ignite flammable vapors. In most forms used in aircraft, steel can be cut with metal cutting saws, but because of the sparks produced, it is a potentially hazardous operation in the presence of flammable vapors.

**8.2.5** Titanium is used primarily in engine parts, nacelles, and for engine fire walls. It is a combustible metal, but in the forms used in aircraft, it has a high degree of heat and fire resistance. Although not easily ignited, it will burn between 1300°C (2372°F) and 1450°C (2642°F). Once ignited, titanium is difficult to extinguish. Water is ineffective. Turbine engine fires involving titanium cannot normally be extinguished by external fire-fighting techniques within the time period necessary to complete rescue operations. Titanium metals have a friction spark hazard similar to steel and magnesium. Surfaces of titanium are very difficult to penetrate, even with power equipment.

**8.2.6** To improve the payload/vehicle-weight ratio of aircraft without compromising structural strength, increasing use is being made of composite materials. They are made of small, fine fibers embedded in carbon/epoxy materials. The fibers are usually boron, fiberglass, aramid, or carbon in the form of graphite. Composite fiber plus plastic materials have replaced metal in many aircraft components, such as engine

nacelles, flaps, floor panels, struts, undercarriage doors, wing structure, tail plane, and horizontal and vertical stabilizers. Temperature-resistant composites can also be found in engine, tire, and brake components. These materials do not present any unusual fire extinguishment problems. However, when cutting composite materials fire fighters should have full body protection including positive pressure self-contained breathing apparatus or a suitable full-face respirator, to prevent injections from fibers into the skin or ingestion into the respiratory system.

**8.2.6.1** The composite materials are bonded together in layers forming a matrix. The types of matrices in use include diglycidyl ether of bisphenol A and polyurethane and urea or phenol/formaldehyde. If composite materials are directly involved in a fire 400°C – 500°C (778°F – 958°F), the resins and bonding agents used decompose, emitting highly toxic fumes in the immediate area.

**8.2.6.2** The hazards associated with an aircraft incident/accident which does not involve a fire are limited to composite material being liberated through abrasion and breakage. With a combination of fire and impact, the risk is higher. Subsequent handling and disturbance of damaged components made from composite materials will liberate additional fibers into the atmosphere.

**8.2.7** Many aircraft cabin materials in current and continuing use as well as newer fire-resistive materials can produce high concentrations of toxic gases when heated even though no open flaming is visible. Some examples are shown in Table 8.2.7. Therefore, it is imperative that positive pressure self-contained breathing apparatus be worn by all fire fighters engaged in rescue, fire-fighting, and overhauling operations.

**Table 8.2.7 Toxic Gases Given Off by Aircraft Materials**

Material	Use	Toxic Gases
Nylon	Seats, curtains, carpeting	Hydrogen cyanide (HCN) Ammonia (NH <sub>3</sub> )
Silk	Headcloth and curtains	Hydrogen cyanide (HCN) Ammonia (NH <sub>3</sub> )
Wool	Seats, curtains, carpeting	Hydrogen cyanide (HCN) Ammonia (NH <sub>3</sub> ) Nitrogen dioxide (NO <sub>2</sub> )
Acrylics	Glazing	Hydrogen cyanide (HCN)
Polystyrene	Insulation	Benzene
Rubber	Wiring systems	Sulfur dioxide (SO <sub>2</sub> ) Hydrogen sulfide (H <sub>2</sub> S)
Urethanes	Seating and insulation	Hydrogen cyanide (HCN) Ammonia (NH <sub>3</sub> ) Nitrogen dioxide (NO <sub>2</sub> )
Melamine	Decorative laminates	Hydrogen cyanide (HCN) Ammonia (NH <sub>3</sub> )

**Table 8.2.7 Toxic Gases Given Off by Aircraft Materials**

<b>Material</b>	<b>Use</b>	<b>Toxic Gases</b>
Polyvinylchloride (PVC)	Wiring insulation, paneling, and trim	Nitrogen dioxide (NO <sub>2</sub> ) Hydrogen chloride (HCl) Carbon dioxide (CO <sub>2</sub> ) Carbon monoxide (CO) Halogen acids
Acrylo-nitrile-butadiene-styrene (ABS)	Window surrounds, seat side paneling	Hydrogen cyanide (HCN)
Fluorocarbon materials	Wiring insulation/covering	Hydrofluoric acid (HF)

### 8.3 Aircraft Fuel Tanks.

**8.3.1** In some aircraft, where the wing joins the fuselage, there is no substantial separation to provide a desired fire wall. As all aircraft have wing tanks, many without separate metal or synthetic bladders within the wing cavity, vapors are seriously exposed under fire conditions. Fuel is carried in storage tanks that are structurally separate but interconnected incorporating vent systems to ensure equalization of pressure and prevent collapse of the tank. Aircraft with a high rate of climb have fuel tanks that are pressurized to prevent the fuel from boiling off or vapor locks.

**8.3.1.1** The principal types of fuel tanks in use are as follows:

- (1) *Rigid Tanks.* Usually made of aluminum or duralumin with internal baffles to brace the tank and reduce surging of fuel. These tanks are normally covered in fabric, fitted with cradles, and held by metal straps.
- (2) *Integral Tanks.* These are shaped by compartments formed by the airframe structure that are made fueltight. The advantage is that this type of tank does not add weight to the structure.
- (3) *Flexible/Semi-flexible Tanks.* These are bags made from plastic or other man-made material that are held in place by rubber buttoned area press studs. The advantage is that they are not ruptured by shock; however, they are susceptible to rupture by piercing.
- (4) *Auxiliary Tanks.* These are normally constructed of metal or fiberglass, and found in the form of pods, which can be fitted under wing, wing tips, or within the fuselage. The fuel in auxiliary tanks is usually used in flight first, and in some circumstances, these tanks may be jettisoned in an emergency.

**8.3.2** Some aircraft carry fuel in the center wing section, which in effect places fuel storage within the fuselage. It is thus possible, under some conditions, for fuel or vapors from tanks damaged due to an aircraft accident to enter the fuselage.

**8.3.3** Currently entering commercial service are wide-body aircraft with provisions for additional fuel storage within both the horizontal and vertical stabilizers. Damage to these tanks in the event of an aircraft accident poses a number of problems, including those where fuel or vapors might enter occupied sections of the aircraft and become ignited. These additional fuel storage locations can complicate the fire-fighting operations and

Copyright NFPA

will require additional agent. (See also *NFPA 403, Standard for Aircraft Rescue and Fire-Fighting Services at Airports.*)

**8.3.4** Wing tanks on some aircraft are located directly above or to the side of landing gear mounts. These tanks have been ruptured during hard landings or other ground accidents.

**8.3.5\*** Aviation fuels that are in use for civil and military aircraft include the following. Fuels for piston driven aircraft are AVGAS (aviation gasoline), automotive gasoline. Fuels in use in turbine engines are Jet A1 (AVTUR) kerosene, Jet B (AVTAG) 60% gasoline 40% kerosene, and Jet A2 (AVCAT) for naval carrier borne aircraft.

## **8.4 Aircraft Exits and Doors.**

**8.4.1** Aircraft exits on transport category aircraft include doors, hatches, and windows of various sizes. These exits will vary with the age, size, and type of the aircraft. ARFF personnel should be familiar with the operation of the various exit types on all makes of aircraft normally using the airport.

**8.4.2** Doors on most older, unpressurized aircraft open outward and can be opened from outside and inside the aircraft.

**8.4.3** The doors on the majority of U.S. built modern pressurized aircraft are called “plug-type” doors. When these doors open, they push in slightly and then pull out or retract upward into the ceiling. These doors are not operable as long as the cabin remains pressurized [as little as 0.015 psi (103 Pa)].

**8.4.4** Aircraft having a door sill higher than 1.5 m (5 ft), with landing gear deployed, are normally equipped with inflatable evacuation slides mounted at the emergency exits. When the system is armed and the emergency exit is opened, the slide can inflate and extend outward in less than 5 seconds with considerable force. ARFF personnel therefore should consult aircraft manufacturer crash charts to be knowledgeable of the areas where those inflatable slides deploy. (See *NFPA Aircraft Familiarization Charts Manual.*)

**8.4.5** If the cabin crew fail to open the aircraft doors, ARFF personnel can gain access by using the emergency door release mechanism situated on or adjacent to the external face of the door. ARFF personnel must be aware of the different external door operations in use; on some aircraft, doors are designed so that on operating the external door opening mechanism, the girt bar will be released automatically, preventing the evacuation slide from deploying. On aircraft where girt bars are manually housed by the cabin crew, if not removed, on opening the door externally, evacuation slides will deploy. However doors should be approached and opened with caution ensuring that the girt bar is disengaged, as the slide may deploy either by design or malfunction. ARFF personnel must be aware of emergency exits where, on operating the internal or external opening mechanism, the door is designed to eject outward with an explosive force to deploy an inflatable slide, for example, B757.

**8.4.6** When positioning ladders, elevated platforms, or mobile stairways prior to opening cabin doors from the outside, care should be taken since all aircraft doors do not open in the same direction, or by the same mode of operation.

**8.4.7** Opening the doors of most modern-type aircraft from the exterior can be accomplished more readily and safely using an aerial platform or a mobile stairway. If these units are not available, a ground ladder can be raised to a position adjacent to the door control mechanism and, if possible, on the side away from the direction the door is to be opened. Once the door is opened the ladder can then be moved into the door opening and secured at the top to prevent movement.

**8.4.8** Overwing exits are part of the emergency evacuation system on several types of aircraft. They might also

be useful as entry points for rescue teams and for facilitating ventilation of the cabin. Some overwing exits are equipped with slides that are similar to door exit slides when deployed.

**8.4.9** Some aircraft have doors that incorporate stairs on the side of the fuselage or in the tail section to facilitate passenger boarding and deplaning. Although in some circumstances they might be used as such, they are not considered emergency exits. ARFF personnel should know which aircraft using the airport have these types of doors and exercise proper caution when the need arises to open them.

**8.4.10** Fires can occur within a cargo hold either from onboard electrically operated equipment or from the cargo carried. Doors to cargo holds have external operating devices that are manually or electrically operated. On the failure of electrical power, doors normally have a secondary means of operation. ARFF personnel should be trained in opening the cargo doors on aircraft using their airport. This should be incorporated into recurrent training programs (*see NFPA 405, Recommended Practice for the Recurring Proficiency Training of Aircraft Rescue and Fire-Fighting Services*).

## Chapter 9 Evacuation and Rescue

### 9.1 Aircraft Evacuation.

**9.1.1** Evacuation of occupants involved in aircraft accidents and assistance to those who cannot remove themselves should proceed with the greatest possible speed. While care is necessary in the movement of injured occupants so that their injuries are not aggravated, removal from the fire-threatened area is the primary objective.

**9.1.2** Flight deck crews receive extensive training in aircraft emergency evacuation procedures. They are in the best position to make optimum decisions relative to evacuation procedures in most emergency situations. They also have immediate contact with those aboard the aircraft and, therefore, can direct the operations.

**9.1.3** Prior to any planned emergency landing, flight deck crews normally will consider passenger relocation within the cabin. This procedure is used to expedite use of potential emergency exits. The practice of placing a crew member, or a person knowledgeable in evacuation procedures, at each exit to assist flight attendants in the direction and movement of occupants is common practice where time and circumstances permit. Under certain circumstances, flight attendants might have the necessary time prior to impact to more fully instruct passengers on how to survive impact and evacuate the aircraft. Training and checklists provide, among other things, for selection of able-bodied helper passengers to receive instructions pertaining to operation of exits and slides. These persons would then be more capable of assisting the flight attendants. Additionally, ARFF personnel should realize that the first passengers to leave the plane might have received instructions to remain at the bottom of a slide, wing, airstair, and so forth. ARFF personnel should direct survivors away from the aircraft and prevent survivors from piling up.

**9.1.4** The tendency toward forward exiting is natural since most passengers boarded the aircraft at terminals through forward doors and will instinctively attempt to exit in the same manner. Other exit facilities are apt to be bypassed, especially if persons are under any mental strain or sense of panic. Overwing and other emergency exits requiring physical agility probably will be shunned by those doubting their ability to use them effectively. Access to overwing and some other emergency exits is usually restricted by seating arrangements. Overwing exits are often smaller than door exits, and have caused passengers to become entangled just inside the exit. If visibility in the cabin is impaired due to darkness or dense smoke, orderly evacuation can be further complicated.



**9.1.5** Limited evacuation options might be available to the flight deck crew due to circumstances aboard the aircraft. One or more emergency exits could be inoperable as the result of distortion caused by impact. Doors might be blocked by loose galley equipment. Aisles might be difficult to travel due to injured passengers, collapse of overhead panels and partitions, dislodged seats, and carry-on items. Although normal evacuation procedures provide for the use of all available exits, flight deck crews are trained to remain flexible and are prepared to select the best means of exit as circumstances and conditions permit.

**9.1.6** Many variations of aircraft accidents are possible, and the flight deck crew can be faced with many decisions in the seconds before or after they occur. ARFF personnel, therefore, cannot expect that standard procedures will be used in all instances and should remain flexible to provide whatever protection and support evacuees should require. In the event that the flight deck crew becomes incapacitated and evacuation does not begin immediately, ARFF personnel should initiate evacuation procedures.

**9.1.7** If fire conditions or fuel spills initially prohibit the use of certain emergency exits, ARFF personnel are usually in a better position to make this observation. The ARFF incident commander should not hesitate to communicate this information to the flight deck crew.

## **9.2 Evacuation Slides.**

**9.2.1** Evacuation slides are provided to expedite occupant egress from aircraft that have normal door sill heights above 1.5 m (5 ft). Because passengers are not trained in proper evacuation slide use, there is a degree of personal injury risk when slides are used. ARFF personnel should expect the occurrence of sprains, bruises, friction burns, and other minor injuries whenever evacuation slides are used. (See *Figure 9.2.1.*)



**FIGURE 9.2.1 Proper Entry and Use of an Evacuation Slide.**

**9.2.2** If, during landing, the nose gear fails, the aircraft might come to rest in a tail-high attitude. The failure of one or more landing gears can result in a nose-high or listing attitude. In these instances, evacuation slides become somewhat ineffective because they do not deploy at the proper angle to the ground. A high percentage of injuries can be expected when evacuation slides are used under these circumstances. ARFF personnel should be able to reduce the amount and severity of injuries and expedite evacuation by manipulating the slides and assisting evacuees. (See *Figure 9.2.2.*)



## **FIGURE 9.2.2 Assisting Evacuees at the Base of an Evacuation Slide.**

**9.2.3** Aircraft evacuation slides are susceptible to heat and fire exposure. They are combustible, and when exposed to radiant heat they melt, then deflate, rendering them unusable. ARFF personnel should protect evacuation slides from heat and flame to the best of their ability but should be extremely careful not to apply foam to the operational area of the slide. Foam on the slide makes it very slippery and increases the descent speed of evacuees, possibly causing severe injuries. (See *Figure 9.2.3.*)

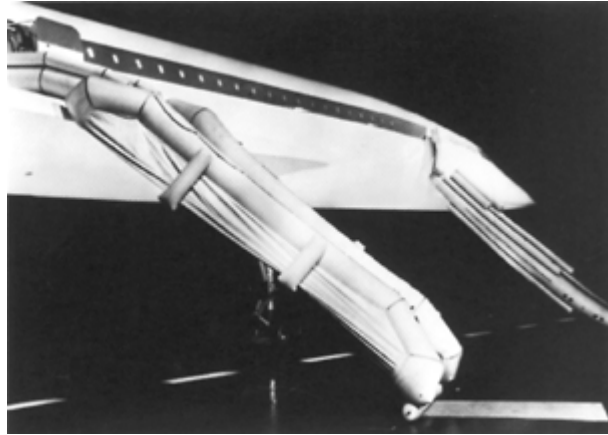

**FIGURE 9.2.3 Two Deployed Evacuation Slides.**

**9.2.4** If time and conditions permit, mobile stairways should be used as an alternative to deploying evacuation slides. This method of evacuation, when there is no immediate danger to aircraft occupants, would prevent many injuries. Response of available mobile stairways should be prearranged between ARFF personnel and one or more of the following:

- (1) Airlines
- (2) Airport maintenance facilities
- (3) Airport operations

## **9.3 Evacuation Assistance by ARFF Personnel.**

**9.3.1** The need to assist in aircraft occupant evacuation depends on a variety of factors. When occupants are self-evacuating, ARFF personnel should support the operation and expedite it where possible. In other instances, actions would depend on the degree of occupant survivability, the fire situation, the condition of exits, and the status of evacuation facilities. In any event, rescue efforts should begin with fire prevention/control and should maintain a safe path from egress points. Evacuees should be directed to an upwind location.

**9.3.2** Fire prevention/control during evacuation should require strategic positioning of ARFF vehicles and applying foam from turrets to establish a blanket covering the Practical Critical Fire Area (PCA). During this operation, emphasis should be placed on maintaining safe egress paths and eliminating the threat of fire extension into the fuselage. Foam handlines, which are more maneuverable than turret streams, should then be employed to protect evacuees and ARFF personnel, extinguish spot fires, and maintain the integrity of the foam blanket. (See also *Chapter 7.*)

**9.3.3** If time and conditions permit, ARFF personnel should assist in the off-loading of evacuees at the base of the evacuation slides to minimize injuries. When high winds or unusual aircraft attitudes cause slides to invert

or malposition, an attempt should be made to align them manually.

**9.3.4** Ground ladders might be needed to assist occupants who have exited onto wing surfaces and those attempting to exit from openings where evacuation slides are unusable. It is important that assistance be given to evacuees using ladders to ensure that they safely complete their exit and that any one ladder does not become overloaded.

## **9.4 Aircraft Forcible Entry.**

**9.4.1** Aircraft involved in accidents can come to rest in almost any attitude. Any abnormal landing force can jam emergency exits. In other instances, the fuselage might be broken open by the impact forces, and doors, windows, and hatches can become dislodged. It is difficult to anticipate the various possible accident conditions, and each incident presents unique problems that must be dealt with. ARFF personnel should be thoroughly trained in forcible entry procedures as well as be provided with a wide variety of tools and equipment necessary to accomplish successful entry and extrication of trapped aircraft occupants. Aircraft rescue and fire-fighting personnel training programs should include a discussion of methods to be used for a situation that involves an aircraft in an inverted position. Such training should include crash charts that depict, in plan view, the entire underside of the various aircraft using the airport.

**9.4.2** In some instances, entry into an aircraft fuselage can only be gained by cutting through the aircraft skin. Knowledge of the aircraft is required to avoid contact with wires, cables, tubing, and heavy structural members. An area of the aircraft normally clear of these features is located in the upper fuselage area above the windows, and any necessary cutting should be attempted in this area. Caution should be exercised to ensure that cutting operations do not endanger trapped occupants.

**9.4.3** Turbine-powered aircraft have heavier skins and structures than the older piston aircraft. Due to this heavy construction, the only practical method of entry, other than using normal or emergency exits, is through the use of portable power tools. Power saws can be used to cut through aircraft skin and structural materials. **CAUTION SHOULD BE EXERCISED WHEN USING SPARK-PRODUCING POWER TOOLS WHERE FLAMMABLE VAPORS EXIST** [see *Figure 9.4.3(a)*]. Claw and pry tools can be used for forcing doors and hatches that are jammed, to pull down panels and partitions, and to dislodge aircraft seats, and so forth [see *Figure 9.4.3(b)*]. The air chisel can be used to cut aluminum and other light metals found on aircraft [see *Figure 9.4.3(c)*]. Hydraulic rescue tools are used to assist with forcible entry during aircraft accident operations [see *Figure 9.4.3(d)*]. These tools take the form of electric-, pneumatic-, hydraulic-, or gasoline-powered cutting, spreading, or shifting equipment. At best, this type of entry into a modern jet aircraft fuselage is very difficult and time consuming. These areas should be depicted on aircraft emergency diagrams. (See *NFPA Aircraft Familiarization Charts Manual*.)

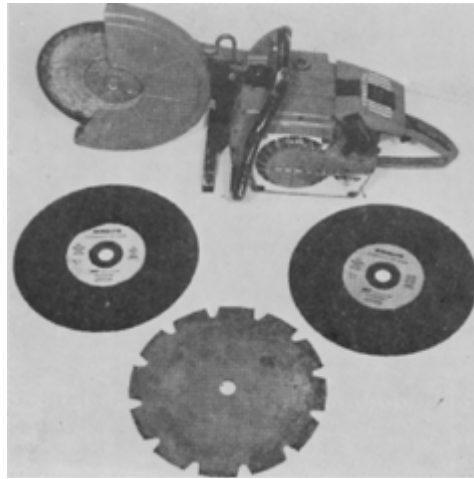

**FIGURE 9.4.3(a) Rescue Saws.**

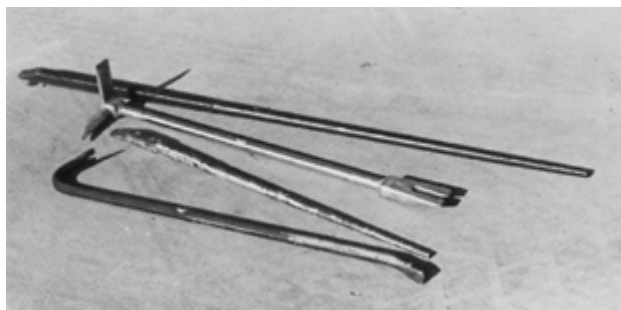

**FIGURE 9.4.3(b) Prying Tools.**



**FIGURE 9.4.3(c) Air Chisel.**



**FIGURE 9.4.3(d) Hydraulic Rescue Tools [from left: life or spread (long), spread cut, and lift or spread (short)].**

**9.4.4** Military combat aircraft present additional hazards due to armament, jettison equipment, and ejection seats. This type of aircraft should always be assumed to be armed. Caution should be exercised in the area at the front of this type of aircraft because it can carry fixed guns and rockets. Unlaunched rockets, when exposed to fire, are dangerous from both front and rear if they ignite. As with any ammunition, keep the rockets cool with foam or water. Further unclassified information should be obtained from the commanding officer of the nearest military installation.

**9.5 Extrication and Rescue.**

**9.5.1** Immediately following the self-evacuation phase of an aircraft accident, a search of the fuselage interior and physical rescue of surviving occupants is crucial. Search and rescue teams should wear full protective clothing and positive pressure self-contained breathing apparatus. They should also be equipped with charged hose lines for their protection and the extinguishment of any fire that might have entered the fuselage. A THOROUGH SEARCH OF THE FUSELAGE INTERIOR AT THIS TIME IS EXTREMELY IMPORTANT. PERSONS, PARTICULARLY INFANTS, CAN BE EASILY OVERLOOKED OR HIDDEN BY DEBRIS.

**9.5.2** Rescue operations should be carried out using normal aircraft openings wherever possible. Occasionally, openings caused by airframe separations can be utilized when it is more convenient and safe to do so.

**9.5.3** ARFF personnel should have a general knowledge relative to the occupant capacity of the various types of aircraft that use the airport. Initial rescue plans should be based on the assumption that occupant load is at maximum.

**9.5.4** The location of occupants in military aircraft can generally be determined by the aircraft type and sometimes by exterior design features such as canopies, gun positions, and so forth.

**9.5.5** Even in survivable aircraft accidents, disruption of the fuselage can be severe, necessitating the improvisation of rescue efforts. ARFF personnel should be skilled in the use of appropriate extrication tools and equipment as well as possess the basic knowledge and skills to properly stabilize an injured occupant prior to removal from the wreckage.

**9.5.6** ARFF personnel rescue and extrication knowledge should include accepted post-aircraft accident procedures, particularly those matters dealing with fatalities and preservation of evidence as described in Chapter 13. If it is necessary to move portions of a damaged aircraft, either in rescue operations or fire control, caution should be taken to avoid changes in the aircraft's stability. Undue strain on the airframe can release fuel from damaged tanks, cause collapse or rollover of the fuselage, or cause greater injuries to trapped occupants.

**9.5.7** Aircraft accidents can occur during temperature extremes. These conditions can seriously aggravate the condition of persons trapped within an aircraft wreckage for an extended period. During this time it is extremely important to maintain the critical body temperature and vital functions of trapped victims. Tarps, blankets, portable lights, fans, oxygen units, and portable temperature control units (heating and cooling) should be immediately available at an accident site. Temperature control units should be designed or located so as not to be an ignition hazard.

**Chapter 10 Fire Control and Extinguishment**

## **10.1 General.**

**10.1.1** The risk of fire at an aircraft accident is due to the close proximity of the systems that contain and distribute the fuel and ignition sources such as heated components in engines and undercarriages, damaged electrical circuits, and friction caused by ground slide.

**10.1.2** Any post-accident fire can seriously affect the ability of the aircraft occupants to evacuate safely and will reduce the time available to mount a successful fire-fighting operation prior to rescue.

**10.1.3** Upon impact, or after a period of time, a fire can develop to severe intensity very quickly and can enter the fuselage through opened exits and openings created by the impact.

**10.1.4** Aircraft designers are continuously studying design factors and construction material changes that will increase “crashworthiness” and limit the development of fire situations that can impede evacuation. Additional modifications intended to increase the impact survivability of occupants are also being developed. Other changes include improved passenger restraints, reduced combustibility of cabin interiors, better marking of exit routes, upgraded emergency exits, and greater emphasis on the training of flight deck crews. If these design improvement measures are as successful as anticipated, the prompt and effective intervention by trained ARFF personnel becomes even more important than at present because a greater number of aircraft accident survivors needing assistance can be expected. ARFF personnel should become intimately familiar with all aircraft types using the airport and should pre-incident plan the optimum rescue and fire-fighting effort that the fire department can produce with the resources it has at its disposal. Careful consideration of the recommendations in this guide can facilitate the development of practical operational plans.

## **10.2 Extinguishing Agents for Aircraft Fires.**

**10.2.1** Aqueous film forming foam (AFFF), film forming fluoroproteins (FFFP), protein foam, and fluoroprotein foam solutions are the primary extinguishing agents preferred for aircraft rescue and fire fighting.

**10.2.2** Complementary extinguishing agents consist of approved dry chemicals or halogenated agents. They are generally best for use on three-dimensional flammable liquid fires or on fires in concealed spaces, such as those occurring behind wall panels, engine nacelles, or wheel wells.

**10.2.3** Experience has shown that dry chemical tends to be more effective than halogenated agents when used in the open air to extinguish three-dimensional fires, while halogenated agents are the preferred agents for electrical fires and in concealed areas.

**10.2.4** If dry chemical or halogenated agent is used, a fire area, once extinguished, could reflash if exposed to a source of ignition; therefore, a follow-up application of foam is recommended when these agents are used.

**10.2.5** AFFF and FFFP should not be mixed with protein-based concentrates. Before film forming foams are used in equipment that formerly contained protein-based foam concentrate, the foam tank and system must be thoroughly flushed with fresh water. The vehicle manufacturer should be consulted to ensure that the agent system design is compatible with the agent to be used.

**10.2.6** AFFF and FFFP are compatible with protein and fluoroprotein foams in the applied form and can be applied simultaneously on the same fire area.

**10.2.7** AFFF and FFFP agents are compatible with dry chemicals. These agents can be applied simultaneously to improve flame knockdown and control fire spread.

**10.2.8** Protein foams should be applied only with compatible dry chemicals. Fluoroprotein foams have demonstrated an improved compatibility with dry chemicals; however, the user should determine that it is adequate to meet operational requirements. If any problems arise, the agent manufacturer should be consulted.

**10.2.9** Protein foams should be applied only with compatible dry chemicals.

**10.2.10** Fluoroprotein foams have demonstrated an improved compatibility with dry chemicals; however, the user should determine that it is adequate to meet operational requirements. If any problems arise, the agent manufacturer should be consulted.

**10.2.11** If foam is being used and the fire is not completely extinguished before the supply is depleted, it might be necessary to complete extinguishment with water streams. When this occurs, avoid applying water or walking in any area that has been secured with foam, as it can break down the established vapor seal that the foam blanket provides.

**10.2.12** If the fire has not been completely extinguished by foam, the secured area will “burn back” at a rate that is dependent on the stability of the foam being used. Also under certain circumstances, fire can “flash back” over a portion of an area covered by foam.

### **10.3 Water and Agent Resupply and Conservation.**

Auxiliary water tankers should be dispatched whenever there is any indication of possible need and especially when the aircraft accident site is known to be beyond water relay capability. Prearrangements should be made to ensure that additional supplies of extinguishing agents are brought to the scene. Prudent utilization of agents under these circumstances is particularly important, and application methods should be carefully selected to ensure their most effective use.

**10.3.1** It is considered impractical to require airport authorities to provide quantities of extinguishing agents to deal with the worst situation that could arise using only the equipment located on the airport. Therefore, it is necessary for airport emergency plans to contain instructions for requesting support from externally based fire services following an emergency. It is not easy to specify an operational requirement that makes adequate provision in all circumstances. It is clear that a need for additional water could arise in as little as 5 minutes, although in this time the initial fire situation should be greatly reduced. If total extinguishment has not been achieved, the fire can quickly extend and the equipment must be replenished.

**10.3.2** Airports should consider providing additional water as a support facility. There might be exceptions where airports have adequate piped, stored, or natural water supplies, provided that these are available at an accident in sufficient quantity and in time to meet the operational requirement.

**10.3.3** In each case, the authority having jurisdiction should consult closely with the Chief Fire Officer of the Mutual Aid Fire Service regarding response and supply of additional water supplies. The airport authority will need to assess the suitability of the water resources which can be mobilized to support the airport fire service when a serious and prolonged post-accident fire occurs. Therefore, the speed of mobilization and the rate at which the water can be delivered to the accident site are important factors.

### **10.4 Rescue Operations.**

**10.4.1** The primary objective of ARFF personnel at the scene of any aircraft accident is to control and extinguish the fire to enable safe evacuation of the aircraft.

**10.4.2** Occupant survival is generally limited to aircraft accidents that are of low impact in nature, where the fuselage is not severely broken up and a fuel fire has not developed. In more severe accidents, even those

where fire does develop, ARFF personnel should assume that there is always the possibility of survivors and take aggressive steps to control the fire, initiate evacuation, and rescue those unable to self-evacuate.

**10.4.2.1** Local procedures should be in place for ARFF/Pilot Communications on a discrete emergency frequency. These procedures should limit the frequency specifically for emergency responders, and pilot usage. Guidelines for this topic can be found in local state publications, for example, A/C 150/5210-7c.

**10.4.3** Rescue operations should begin as soon as conditions permit and often are a simultaneous function during the fire-fighting phase that requires considerable coordination. The rescue team's mission includes assisting evacuees, accomplishing forcible entry if necessary, completing interior extinguishment, extricating trapped survivors, and removing the injured to safety.

**10.4.4** One rescue team method consists of four ARFF personnel equipped with full protective clothing and positive pressure self-contained breathing apparatus (SCBA). Two of the persons are handline operators and precede the other two, who are equipped with appropriate hand-held tools needed for forcible entry, extrication, and making access to hidden fuselage fires behind panels, floors, and compartments. A procedure preferred by some fire departments is to provide an additional handline operator, similarly attired and equipped with SCBA, operating behind the rescue team with a spray stream, as their protection throughout the entire operation.

## **10.5 Size-Up (Risk Assessment).**

**10.5.1** The process called size-up (risk assessment) merely means the gathering of facts in preparation for making decisions. The facts pertaining to an aircraft accident, when mentally assembled, enable the responsible ARFF officer to establish both initial tactics and overall strategy.

**10.5.2** The size-up (risk assessment) process is initiated by the first-responding ARFF officer and is carried on throughout the duration of the incident in terms of depth and scope by later-arriving superior officers.

**10.5.3** When an aircraft accident occurs, some size-up (risk assessment) information in the form of established facts should be immediately known as the result of training, pre-incident planning, knowledge of available resources, and interpretation of alarm information. Additional facts become known through observation during response and upon arrival at the scene.

**10.5.4** Vital operational decisions based upon initial size-up (risk assessment) information should be made without delay. Realistic objectives are critical, and consideration should be given to the capabilities of resources that are immediately available.

**10.5.5** Initial assignments of tasks based on the size-up (risk assessment) are generally not fixed and tend to be modified as the incident develops. The size-up (risk assessment) process should continue throughout the duration of the incident, and any changes in strategy or objective that develop should be communicated to key personnel involved in the operation.

## **10.6 Aircraft Accident — Fire Involvement.**

**10.6.1** In an aircraft accident, occupants are confined within the fuselage and are surrounded by very large amounts of fuel that, when ignited, can release heat at about five times the rate that develops in the typical structure fire. An aircraft fuselage has a very low resistance to fire, except for engine areas, cargo compartments, and galleys, as fire and smoke barriers are nonexistent.

**10.6.2** The priority should be given to aircraft occupant survival. Those who have survived the impact forces then face the exposure to fire and toxic products of combustion. Total extinguishment of the fire is an



acceptable initial approach if it is determined to be the most effective method of successfully accomplishing rescue. A resource-conserving alternative would be selective control of fire in areas where occupants are successfully evacuating and maintaining these escape routes until it has been determined that evacuation is complete. A decision as to the precise method of initial fire attack should be made by the ARFF incident commander immediately upon arrival at the scene. All members of the ARFF team should realize that initial plans are always subject to change and should remain alert for orders that alter operations as conditions dictate.

**10.6.3** If upon arrival at an aircraft accident the operator of the first-arriving ARFF vehicle encounters a small fire, the best tactic would be to extinguish it rapidly and then begin to blanket any fuel spill with foam. Later-arriving vehicles should assist in the foam application if needed or perform other tasks as directed by the incident commander.

**10.6.4** If a large fire is in progress upon arrival of the ARFF personnel, foam should be applied using the vehicle turrets. Since initial foam supplies can be exhausted in 2 minutes, turret operators should understand that foam application by this method must be effective and that streams should be shut down on occasion to assess progress and conserve foam. Once a fire has been controlled and any fuel spill blanketed with foam, consideration should be given to employing foam handlines that are more maneuverable and, therefore, more effective for maintaining a foam blanket and extinguishing small fires.

**10.6.5** If foam becomes contaminated by fuel splashing into it, then at some time the foam will become flammable. The degree to which this is a problem depends on the type of foam and the amount of contamination. As solution drains from the foam, the water drains at a faster rate than the fuel, resulting in a fuel-rich foam matrix that can ignite if exposed to a source of ignition. This problem is more evident in AFFF than in other foams because it has a much faster drainage rate and becomes flammable at a lower level of contamination.

**10.6.6** Protein and fluoroprotein foaming agents should form a blanket over the surface of a flammable liquid fire in order to extinguish it. The foam should be applied using a dispersed pattern over the surface of the burning fuel to completely cover the spill area. It needs to be applied in such a manner that it does not break up any previously established blanket. If isolated openings in the foam blanket occur, they should be filled in as soon as possible with new foam.

**10.6.7** AFFF and FFFP agent solutions can be applied either with aspirating nozzles, turret nozzles used for protein and fluoroprotein foams, or conventional water spray nozzles. Either spray or straight streams can be used as the situation dictates. It is best to approach the fire area as closely as possible and apply the foam in a wide spray pattern initially, changing to a narrower pattern after the heat has been reduced. The stream should be applied in a gentle manner to avoid unnecessary plunging of the stream into the burning fuel. The foam should be applied to the near edge of the fire with a rapid side-to-side sweeping motion to distribute the foam rapidly and thinly over the burning fuel. Advance as the fire is controlled, always applying the foam to the nearest burning fuel surface. Advance only after a continuous, unbroken foam cover is established. The entire foam blanket integrity should be maintained to compensate for voids created by movements of ARFF personnel, evacuees, and equipment, as well as the normal draindown of the foam.

## **10.7 Extinguishment Techniques.**

**10.7.1** Vehicle approach to a burning aircraft should be such that turret streams can be applied along the length of the fuselage with efforts concentrated on driving the fire outward while keeping the fuselage cool, protecting occupants as they evacuate, and assisting with the entry of rescue teams.

**10.7.2** The location of survivors, if known, and the area of fire will determine where the first streams should be applied. If the fire has penetrated the fuselage, a direct interior attack with handlines should be initiated as

soon as possible.

**10.7.3** Where it is compatible with the evacuation process, it is best to approach an aircraft fire from the windward side. Agents should be applied from the windward side to provide better reach and greater ability to monitor extinguishing effectiveness, as the heat and smoke will be moving in the opposite direction. When vehicle turrets are in operation on opposite sides of a fuselage, care should be taken so that the fire is not driven underneath from one side to the other.

**10.7.4** When an aircraft comes to rest on sloping terrain or adjacent to a gully or wash, circumstances permitting, the fire should be approached from high ground and the burning fuel driven away from the fuselage.

**10.7.5** Aircraft accidents do not occur under the best conditions or permit the ideal conditions for combating a fire. It will not always be possible to approach the fire from high ground or the windward side. What is important is an aggressive attack to isolate the fuselage from the fire and efficient fireground coordination to achieve a successful evacuation of occupants and complete fire extinguishment.

**10.7.6** The initial attack on an aircraft fuel fire should normally be by judicious application of foam, or alternatively by the combined use of foam and a complementary agent. A three-dimensional or flowing fire should be extinguished by using an approved dry chemical or halogenated agents, followed by an application of foam. Even where foam alone is used, a suitable complementary agent should be available to deal with fire inaccessible to direct foam application.

**10.7.7** If a fire threatens exposed aircraft, structures, or other combustibles, they should be protected by foam or water spray. Note that water streams or runoff should not be permitted to destroy any foam blanket in the critical fire area.

**10.7.8** If a large fuel spill occurs without igniting, it is important to eliminate as many ignition sources as possible while the spill is being stabilized with a foam blanket. There can be enough residual heat present in jet engines to ignite fuel vapors 30 minutes after shutdown.

**10.7.9** Extinguishing agents should be applied in a manner to avoid spot cooling of components that can cause stress failure and disintegration. If possible, streams should be employed so that even surface cooling can result. Approved dry chemicals and halogenated agents can extinguish fires involving hydraulic fluids or lubricants, but they lack the cooling ability necessary to prevent reignition.

## **10.8 Turret Operations.**

**10.8.1** ARFF vehicles should be positioned to make the most effective use of all extinguishing agent systems. The most efficient use can require movement of the vehicle during turret or even handline operations. It is vitally important not to waste available agent. **TURRETS SHOULD BE USED ONLY AS LONG AS THEY ARE BEING EFFECTIVE.** After initial knockdown of the heat and flame, use of handlines to maintain control of evacuations areas can be the key to a successful rescue operation.

**10.8.2** When selecting vehicle positions for applying foam from a turret, remember that wind has a considerable influence upon the quality of the foam pattern and the rate of fire and heat travel. Utilize the wind whenever possible to achieve more effective fire control.

**10.8.3** Turret application should never be directed so as to drive fuel or fire toward the fuselage. The main objective is to maintain an escape route for occupants until complete evacuation is achieved.

**10.8.4** Usually water supplies are a key factor, and turret operators should concentrate their extinguishing

efforts on the escape route from the aircraft.

**10.8.5** The “pump and roll” concept, a method of applying agent from a turret while the vehicle is in motion, can be a very effective fire control technique when used correctly.

### **10.9 Aqueous Film Forming Foam (AFFF) and Film Forming Fluoroprotein (FFFP) for Turret Application.**

**10.9.1** The basic principle is to distribute a visible AFFF or FFFP blanket of sufficient thickness over the burning fuel to act as a blanket for vapor suppression. The original blanket should not be relied on to be permanent and should be maintained as necessary until the fuel vapor hazard no longer exists.

**10.9.2** Both aspirating and nonaspirating nozzles can be used for AFFF or FFFP application. A nonaspirated nozzle typically provides longer reach and quicker control and extinguishment. However, expansion rates and foam drainage times are generally less when AFFF or FFFP is applied with nonaspirating nozzles, and it should be understood that the foam blanket might be less stable and have a lower resistance to burnback than that formed using aspirating nozzles. Manufacturers should be consulted for guidance on nozzle performance. Extreme caution should be taken when using the straight stream method as this can cause an increase in the liquid pool surface or cause an opening in the foam blanket, releasing flammable vapors.

### **10.10 Protein and Fluoroprotein Foam Turret Application.**

**10.10.1** Protein and fluoroprotein foams should be applied to burning fuel so that they gently form a uniform and cohesive blanket with the least possible turbulence to the fuel surface.

**10.10.2** Aspirating nozzles should be used for applying protein and fluoroprotein foams in either the straight stream or dispersed patterns to distribute the foam over a wide area. When using the straight stream method of application, the foam should be applied indirectly using deflection techniques, and special care should be exercised to avoid disturbing the established foam blanket.

### **10.11 Handline Foam Application.**

**10.11.1** As soon as the fire has been knocked down by turrets, they should be shut down, perhaps repositioned, and held in a state of readiness to resume operation should the need occur. During this phase of rescue and fire fighting, handlines are more effective than turrets in controlling the fire, maintaining rescue paths for occupants, mopping up spot fires, maintaining the foam blanket, and conserving vital agent supply.

**10.11.2** Whether or not there is an immediate need for them, charged handlines should be placed in strategic positions as soon as possible after ARFF personnel arrive on the scene. This practice would ensure their immediate availability for use when the need arises.

**10.11.3** Foam application principles are the same for handlines as they are for turrets.

### **10.12 Aircraft Accident — No Fire Involvement.**

At an aircraft accident without fire, appropriate fire prevention measures should be initiated immediately.

**10.12.1** All spilled fuel should be covered with foam. Engines and other heated surfaces should be cooled with foam or water fog to prevent ignition. Care should be taken so that the seal established by the foam blanket is not washed away or diluted by the water spray.

**10.12.2** The washing of spilled fuel from around the aircraft requires caution. Raw fuel and flammable vapors should be directed away from sources of ignition.

**10.12.3** Every effort should be made to prevent sparks whenever there is the possibility of exposed fuel or fuel vapors in the area. Particular care should be taken to prevent sparks due to arcing before the aircraft electrical system can be de-energized.

**10.12.4** ARFF need to exercise extreme care when cutting tools are used at the accident site where fuel liquid and vapor is present. A support fire fighter should be on standby with a fully charged hoseline to deal with any incipient fire that might develop.

### **10.13 Exposure Protection.**

**10.13.1** After rescue of occupants, protection of exposed property should be the next consideration at the scene of an aircraft accident, whether fire exists or not. In addition to airport structures and other aircraft, plans should include preventing contamination and fire spread into drains, sewers, waterways, and any belowground facilities. Authorities should be immediately notified of any exposure to fire or contamination involving property under their control.

**10.13.2** Early and effective fire extinguishment ensures the least amount of property loss, and that includes exposed properties whether involved in fire or not. Where resources are limited, conditions will dictate which exposures receive first priority for protection.

## **Chapter 11 Interior Aircraft Fires**

### **11.1 General.**

**11.1.1** The recommendations contained in this chapter are provided for the guidance of ARFF personnel encountering interior aircraft fires occurring in both parked unoccupied aircraft and aircraft with passengers and crew aboard.

**11.1.2** The occurrence of interior aircraft fires where passengers and crew are onboard presents a major problem for ARFF personnel. An acute life safety hazard exists in these instances, and the ability to enter the aircraft and extinguish the fire might have to be delayed until evacuation has been completed. Because forcible entry and rescue are discussed in detail elsewhere in this guide, they will not be covered here, and instead emphasis will be on the procedures and techniques of attacking and extinguishing interior aircraft fires.

**11.1.3** Aircraft passenger cabin fires normally involve ordinary combustibles such as upholstery, paneling, carpeting, refuse, electrical insulation, and carry-on materials. Generally, a direct attack on the fire with water streams, using structural fire-fighting techniques, is effective.

**11.1.4** ARFF personnel should understand the structural characteristics of an aircraft fuselage. The absence of fire stops at the floor, behind wall panels, and above ceiling areas permits fires to spread undetected and unchecked through combustible materials once fire has entered those areas. ARFF personnel should always assume, until it is proven otherwise, that fire has moved away from its origin via these concealed spaces. Sections of flooring, wall panels, and ceilings should be removed where fire travel is suspected so that complete extinguishment can be accomplished.

**11.1.5** Since the burning of aircraft interior materials creates a toxic atmosphere, ARFF personnel should wear positive pressure self-contained breathing apparatus whenever working inside the fuselage both during the fire-fighting stage and later, while overhauling. Additionally, the entire fuselage should be ventilated as quickly as possible by whatever means available. Ventilation fans can expedite horizontal ventilation, which are usually the only choice of methods since an aircraft has no designed vertical openings. *[See Figure*

11.5(b).]

**11.1.6** Interior aircraft fire situations can differ widely; therefore, explicit guidance regarding extinguishment techniques is not possible. Points of entry and methods of attack should be dependent upon an evaluation of conditions and assessment of resource capability by the ARFF incident commander.

**11.1.7** An interior aircraft fire location and its intensity can to some degree be determined by observation through cabin windows, smoke characteristics, or aircraft skin that shows buckling or paint blisters.

**11.1.8** In the event that an interior aircraft fire cannot be immediately extinguished, foam or water spray should be applied to wing and fuselage fuel tank areas that might be exposed to heat.

## **11.2 Aircraft Interior Fires Occurring in Flight.**

**11.2.1** A major hazard of commercial aviation is the in-flight fire that cannot be controlled by onboard portable extinguishers or fixed extinguishing systems.

**11.2.2** Aircraft emergency landings or accidents can be the result of uncontrolled fires occurring in flight. The most frequent types of in-flight fires involve all of the following:

- (1) Engines
- (2) Cabin areas
- (3) Lavatories
- (4) Heaters
- (5) Cargo areas
- (6) Electrical compartments

**11.2.3** Portable fire extinguishers are required to be mounted at specific locations in the cabin of passenger aircraft, and flight deck crews receive periodic training in their use. The extinguishers are designed to handle incipient fires in accessible areas. However, fires can and do originate in locations not readily accessible from the cabin while the aircraft is in flight. If the area involved in fire is isolated and is not equipped with a fixed extinguishing system, a serious fire can develop and spread rapidly.

**11.2.4** When an uncontrolled in-flight fire occurs, the aircraft must make an emergency landing at the nearest suitable airport, and the occupants must be evacuated before being overcome by heat, smoke, and toxic gases. ARFF personnel are usually notified of such emergencies well in advance of the landing and should be prepared to assist in the immediate evacuation and to enter the aircraft and extinguish the fire.

**11.2.5** When the aircraft is on the ground and whether or not the air-conditioning system is operating, heat, smoke, and gases will build up, creating a toxic atmosphere and setting the stage for a flashover.

**11.2.6** After the aircraft has landed and the flight deck crew has initiated emergency evacuation, it should be assumed that some of the occupants might not have the ability to self-evacuate. ARFF personnel should allow normal procedures to be carried out to their full potential without compromising the evacuation process; however, ARFF personnel and vehicles should be placed in strategic positions to effect entry into the fuselage to confirm complete evacuation and achieve fire control.

**11.2.7** If there is no evidence of occupant evacuation, immediate steps should be taken to make entry for control of the fire and rescue of occupants. Entry will permit an inrush of fresh air into a possibly overheated or unstable atmosphere that could rapidly accelerate the fire. Toxic gases will be present, so ventilation and a

thorough search for survivors should take place immediately and simultaneously with the fire-fighting effort. In darkness or heavy smoke conditions these efforts will be much more difficult.

### **11.3 Interior Fires in Unoccupied Aircraft.**

**11.3.1** Fires occurring in unoccupied aircraft often result in delayed detection. An unattended aircraft with its doors closed can contain a smoldering fire that can burn unnoticed for an extended period of time. Under these conditions, a build-up of extremely hot fire gases can develop as the fire consumes all the available oxygen. Opening up an aircraft under such circumstances can be very hazardous because when oxygen is introduced into such an atmosphere, the entire interior can become immediately ignited, possibly with explosive force. Handlines that are fully charged need to be in place prior to entry into the fuselage.

**11.3.2** When arriving at a closed, unoccupied aircraft that is suspected of having an interior fire, the internal atmosphere should be assessed before entry is attempted. If flame cannot be seen, and the windows are hot to the touch and obscured by heavy smoke, it can be expected that a hot, smoldering fire exists and entry of outside air at this time would ignite the entire interior.

**11.3.3** If an interior fire in an unoccupied aircraft has not reached the smoldering stage, there is sufficient oxygen present and a free-burning fire can be maintained. Under these circumstances, entry should be made and the fire extinguished with water or foam in the conventional manner.

**11.3.4** Extinguishment of a hot, smoldering, internal aircraft fire can be very difficult. Where this type of fire exists, one method is worth consideration. It can be referred to as an indirect attack that is made from small fuselage openings such as slightly opened exits or openings made in cabin windows. A coordinated multiple-point attack is more effective than a single-point attack and is a necessity when applying the method to fires in wide-body or jumbo aircraft with large volume interiors. It must be remembered that this method is not suitable if there is any possibility of occupants being onboard the aircraft.

**11.3.4.1** The extinguishment principle of this indirect method is based on the conversion of water spray into steam as it contacts the super heated atmosphere within an enclosure. The rapid expansion of water spray droplets into minute steam droplets increases the surface area of the water, permitting it to absorb more heat, thus making it more efficient as a cooling agent. Water in this form and under pressure has the ability to penetrate dense burning materials and enter areas behind panels and coverings. When properly applied, the method lowers the temperature of the entire fire area to a point where combustion ceases.

**11.3.4.2** Should a smoldering, interior aircraft fire occur in compartments below the passenger and flight deck levels, the indirect attack method can also be applied, adapted to the particular circumstances involved. More difficulty can be experienced in achieving convenient openings in these compartments, however. Consideration should be given to attacking fires in these areas through openings in the cabin floor.

### **11.4 Penetrating Nozzles.**

**11.4.1** The use of penetrating nozzles is another way of combating aircraft cabin and compartment fires. Most penetrating nozzles are designed so that any agent currently used by ARFF providers can be utilized.

**11.4.2** To extinguish an aircraft cabin or compartment fire using penetrating nozzles, the total fire area requiring agent application needs to be considered. For example, to extinguish a large fire in the cabin of a wide-body aircraft, penetrating nozzles injecting agent simultaneously from dispersed, multiple injection points would be required to provide a sufficient amount of agent to effect extinguishment in a timely manner.

**11.4.3** Currently, there are a number of penetrating nozzles in use. The manner of application can be slow, awkward, and occasionally dangerous when applied to aircraft fire fighting and should be done with great care.

When using this type of penetrating nozzle, ARFF personnel should make certain that they have proper footing and sufficient operating area, and have an understanding of aircraft design and construction and emergency access points of entry. (See *Figure 11.4.3.*)



**FIGURE 11.4.3 Aircraft Skin Penetrator Nozzle.**

**11.4.4** The skin penetrating agent applicator tool (SPAAT) was introduced by the U.S. Air Force. This tool incorporates a pneumatic device that drills through aircraft skin and windows within 10 seconds and can immediately inject any of several agents into the fuselage. (See *Figure 11.4.4.*)



**FIGURE 11.4.4 Skin Penetrator Agent Applicator Tool (SPAAT).**

### **11.5 Interior Aircraft Fire Overhaul.**

During the overhaul phase of an interior aircraft fire, hose lines should remain charged and available to extinguish any deep-seated fire, hidden uncovered fire, or reignition. Carpeting, wall panels, partitions, and ceiling covering should be removed when necessary to ensure that all fire is extinguished and that there is no threat of reignition. The use of portable lighting units and ventilation fans will help to make the aircraft interior safer and more tenable for ARFF personnel. [See *Figure 11.5(a)* and *Figure 11.5(b).*] Any person entering the aircraft during the overhaul phase should use positive pressure self-contained breathing apparatus.

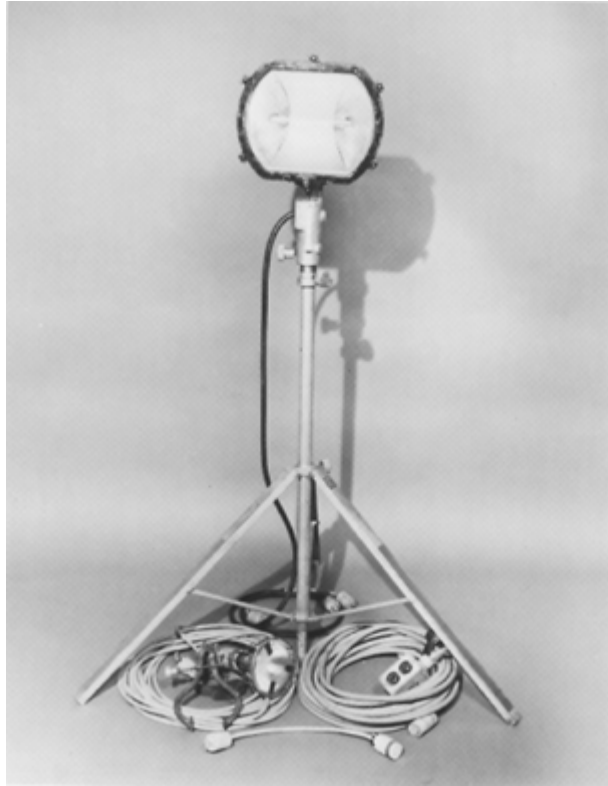

**FIGURE 11.5(a) Portable Lighting Units.**

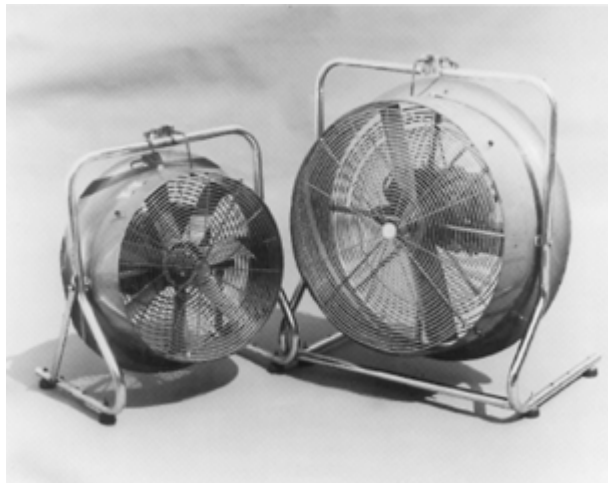

**FIGURE 11.5(b) Ventilation Fans.**

## Chapter 12 Miscellaneous Aircraft Incidents

### 12.1 General.

**12.1.1** Each year ARFF personnel respond to numerous incidents on-airport that are considered “minor.” These seemingly routine activities do not make headlines, but the absence of intervention could often result in catastrophic loss of life, serious injuries, and extensive property loss.

**12.1.2** Guidance presented in this chapter is intended to inform ARFF personnel of a variety of aircraft  
Copyright NFPA



incident types and how to deal with them so that the hazards relative to aircraft operations on-airport can be safely abated.

## **12.2 Engine Fires.**

**12.2.1** It is reasonable for ARFF personnel responding to aircraft engine fires to expect that all of the following actions have probably been accomplished by the flight deck crew, where appropriate:

- (1) Engine shut down
- (2) Engine fire extinguishing system (if any) activated
- (3) Electrical power to the affected engine(s) de-energized
- (4) Fuel and hydraulic fluid supply to the affected engine(s) shut down

These actions should be verified as conditions permit. It should be emphasized that turbine engines, following shutoff of power and fuel, can remain a potential hazard during “wind down” with high heat retention continuing for as long as 30 minutes. This heat constitutes a potential ignition source for flammable vapors. On propeller-driven or rotary-wing aircraft, contact with propellers, or entry into their path of rotation, should be avoided during all stages of the emergency.

**12.2.2** When jet engines are started or shut down in certain wind conditions, hot starts or tail pipe fires can occur. These fires can usually be controlled by the flight deck crew. In some cases, however, fire department intervention might be necessary.

**12.2.3** When reciprocating engine fires are confined within the nacelle, but cannot be controlled by the aircraft extinguishing system, dry chemical or a halogenated agent should be applied first, as these agents are more effective than water or foam for fires inside an enclosure. Foam or water spray should be used to cool the outside of the nacelle.

**12.2.4** Fires confined to the hot section of jet engines can be best controlled by keeping the engine rotating. Such action should be considered in the context of necessary aircraft evacuation and other safety considerations. Fires outside the combustion chambers, but confined within the nacelle, are best controlled with the engine’s fixed extinguishing system. If the fire continues after the system has been discharged, or if reignition occurs, an extinguishing agent should be applied through the maintenance openings. In order to carry out post-fire inspections, ARFF personnel should be aware of the methods of opening the engine nacelle and the subsequent danger of pooled hot fuel contained within the nacelle. The aircraft operator should be advised of the type of extinguishing agent used in order that appropriate maintenance action can be taken.

**12.2.5** Foam or water should not be applied to either the intake or exhaust of a jet engine unless control cannot be secured or confined to the engine nacelle using a halogenated agent or dry chemical. If foam or water is applied to either the intake or exhaust, ARFF personnel should stand clear to avoid being struck by disintegrating engine parts.

**12.2.6** Most jet engines are constructed with magnesium and titanium parts that, if ignited, are very difficult to extinguish. If these fires are contained within the nacelle, they should be permitted to burn themselves out as long as the following conditions exist:

- (1) There are no external vapors present that cannot be eliminated.
- (2) Sufficient foam or water spray is available to maintain the integrity of the nacelle and surrounding exposed aircraft components.

**12.2.7** When tail pipe fires occur in the elevated center engine of three-engine wide-body aircraft or a B-747 auxiliary power unit, special elevating equipment might be required to effectively discharge agent on the fire. (See also Annex C.)

**12.2.8** ARFF personnel should be able to identify aircraft with an external APU control panel and the method of operation to shut down the APU and discharge the internal fire-fighting agent. On fires contained within tail pipes, ARFF personnel should carry out an internal post-fire inspection of the rear bulkhead (where applicable) to ensure that the fire has been contained within the engine or APU and that heat has not been transmitted by conduction.

### **12.3 Aircraft Fuel Servicing Incidents.**

**12.3.1** A number of aircraft fires have occurred during fuel servicing. Ignition has been caused by static developed in flowing fuel, surface-generated static within an aircraft fuel tank, or refueling vehicle, defective fuel pumps, an external source of ignition, and other improper fueling procedures. Defueling and fuel transfer operations are also serious fire potentials. Standards relative to aircraft fueling procedures and proper equipment maintenance should be diligently enforced by the authority having jurisdiction on the airport.

**12.3.2** Fuel spills exterior to the aircraft should be handled in the manner described in NFPA 407, *Standard for Aircraft Fuel Servicing*, when fire does not occur. If fire does occur, it should be handled similar to any other aircraft accident, with primary emphasis on life safety. The practice of fueling occupied transport category aircraft necessitates that, in the event of a fuel spill fire, an immediate check of the interior for occupants is imperative.

**12.3.3** Many transport category aircraft have ganged fuel tank vents near wing tips. Vented JET A type fuel (kerosene grades) vapors normally present very little hazard. If tanks are overfilled, the fuel will discharge through the vents, causing a fuel spill. There is a greater potential for a flammable vapor-air mixture being present in the immediate vicinity of wing tip vents when JET B fuel is used. Regardless of which fuel is used, it is good practice not to position or operate vehicles within a 8-m (25-ft) radius of aircraft fuel system vent openings.

### **12.4 Hot Brakes and Wheel Fires.**

**12.4.1** The heating of aircraft tires causes overpressure and presents a potential explosion hazard. Good judgment should be exercised in determining the severity of the situation, and this information should be conveyed to the flight deck crew. The flight deck crew in turn can assist the rescue and fire-fighting effort by performing necessary procedures (i.e., shut down engines, extend flaps, prepare evacuation, etc.).

**12.4.2** In order to avoid endangering ARFF personnel and aircraft occupants and causing unnecessary damage to the aircraft, it is important not to mistake hot brakes for brake fires. Hot brakes normally cool by themselves and do not require an extinguishing agent.

**12.4.3** When a hot brake condition occurs on a propeller-driven aircraft, it is usually beneficial to keep the propeller operating that is directly forward of the wheel with hot brakes until the brakes have cooled. Larger, modern aircraft have fusible plugs mounted in the wheels that fail at high temperatures, allowing the tires to deflate before dangerous pressure can develop.

**12.4.4** ARFF personnel should remain clear of the sides of aircraft wheel assemblies that are involved in fire and approach only in a fore and aft direction. Since heat is transferred from the brake to the wheel, extinguishing agent should be applied to the brake area. The primary objective is to prevent the fire from spreading upward into the wheel wells, wings, and fuselage.

**12.4.5** Foam, water spray, halogenated agent, and dry chemical are effective agents for direct application on brake fires.

**12.4.6** Dry chemical agents and halogenated agents might extinguish fires involving hydraulic fluids and lubricants, but re-ignition can occur since these agents lack sufficient cooling effect. Halogenated agents are particularly effective in extinguishing undercarriage fires; however, where magnesium wheel components are burning, halogenated agents should not be used.

**12.4.7** Effectiveness of any gaseous extinguishing agent can be severely reduced if wind conditions are such that sufficient concentration cannot be maintained to extinguish the fire.

**12.4.8** Solid streams of water should be used only as a last resort on wheel fires since the rapid cooling can cause an explosive failure. However, fires involving magnesium wheels have been successfully extinguished by applying large amounts of water from a distance. This method rapidly reduces the heat to a point below the ignition temperature of the magnesium, and the fire is extinguished. ARFF personnel should exercise extreme caution when this method of extinguishment is used, as explosive failure of the wheel components is likely.

### **12.5 Combustible Metal Fires.**

Burning magnesium or titanium parts should be isolated if possible and extinguished by applying a Class D agent. Covering the burning metal with dry, uncontaminated sand can be effective when a Class D agent is not available.

### **12.6 Broken Flammable Liquid Lines.**

Broken fuel, hydraulic, alcohol, and lubricating oil lines should be plugged or crimped when possible to reduce the amount of spill potential.

### **12.7 Heater Fires.**

Heaters located in wings, fuselage, and tail sections of aircraft can be protected with a fixed fire extinguishing system. It can be assumed that in the event of an airborne heater compartment fire, the system would have been activated. After the aircraft has landed, a thorough check of the heater compartment and surrounding area should be made to ensure that there has been no reignition or spread of fire.

### **12.8 Bomb Threats/Security.**

**12.8.1** Incidents of unlawful acts including terrorism have forced airports to implement ever increasing security measures, often impacting the operation of emergency services.

**12.8.2** Pre-planning and response protocols must be in effect for mutual aid responders to access staging areas and the accident site. Protocols must ensure that only authorized persons are granted access to the operating interior of the airport.

**12.8.3** When a bomb threat involving an aircraft is declared an emergency, the aircraft should be evacuated without delay. Passengers should be directed to leave their carry-on materials and depart the aircraft as quickly as possible. The situation might dictate the use of the emergency evacuation slides or built-in stairs. Use of portable stairways might be the safest and most practical alternative.

**12.8.4\*** Immediately after evacuation has been completed, the aircraft involved will normally be moved to a remote location designated by the authority having jurisdiction.

**12.8.5** Airport pre-incident plans should incorporate assignment of initial responsibility in any bomb threat

emergency for initiating protective measures, conducting and controlling any search activities, transferring their responsibility, and declaring the termination of the emergency.

**12.8.6** The role of the ARFF personnel in bomb threat emergencies should be limited to the following:

- (1) Assisting occupants evacuate the aircraft
- (2) Assuming a standby status and remaining in readiness after evacuation is complete and the aircraft has been moved to a safe location
- (3) In the event of a bomb detonation, assuming command and control of any rescue operation or fire incident that results

**12.8.7** The airline is responsible for the safety and well-being of its passengers and resources, and should cooperatively assist local authorities in any search of the aircraft or its contents.

## **12.9 Incidents Where Aircraft Fire Warnings Occur.**

**12.9.1** It is often difficult for the flight deck crew to accurately evaluate conditions following actuation of an aircraft fire warning indicator. Therefore, the aircraft should be brought to a stop after clearing the runway and before approaching the terminal. ARFF personnel should inspect the affected area by checking for external evidence of smoke or heat. If no evidence exists, the aircraft should continue on to the terminal where a more thorough inspection can be made.

**12.9.2** If there is evidence of fire, immediate access should be made and the fire extinguished. If this occurs the aircraft should be shut down and the decision made as to whether an evacuation of occupants should take place. Airline maintenance personnel and equipment should be requested to respond and assist ARFF personnel in gaining access and operating ground power units, and should assist with portable stairways if needed for evacuation.

## **12.10 Emergency Landings.**

**12.10.1** Often, landing gear stuck in the retracted position is the result of broken hydraulic lines or loss of electrical power. Spilled hydraulic fluid can ignite in the wheel wells due to the presence of electrical shorts, friction sparks due to a wheels-up landing, or other heat sources. Should ignition occur, the fire has a tendency to travel up into the fuselage and can rapidly become a major interior fire. ARFF personnel should take immediate steps to ensure the stabilization of this problem even though appearances from the exterior do not immediately indicate the presence of fire.

**12.10.2** Hydraulic problems on landing aircraft can involve the brake systems, flaps, spoilers, and so forth. This has a tendency to lengthen the rollout after touchdown and can also affect the aircraft's directional control. As soon as the aircraft touches down and passes each ARFF vehicle that is standing by, that vehicle should immediately follow the aircraft and be ready to perform any necessary operation when it comes to a stop. **IT IS EXTREMELY IMPORTANT THAT ALL OTHER AIRPORT VEHICLES AND PERSONNEL REMAIN CLEAR OF THE AIRCRAFT, THUS PERMITTING ARFF VEHICLES AND PERSONNEL TO MANEUVER AND POSITION FOR EFFECTIVE RESCUE AND FIRE FIGHTING.**

**12.10.3** At emergencies involving landing gear malfunctions or tire problems, there is always a possibility of the aircraft veering off the runway after landing and hitting standby ARFF vehicles. It is difficult to predict the touchdown point. Therefore, if there are two or more ARFF vehicles available, one vehicle should stand by on the opposite side of the runway, a suitable distance from the edge.

## **12.11 Aircraft Accidents in the Water.**

**12.11.1** Many aircraft accidents in the water have occurred in the critical response area off the end of the runway. Where runways terminate adjacent to a significant body of water, special provisions should be made to ensure the rapid response of ARFF services. For any aircraft overrunning or landing short of the runways, response times should be as close as possible to those of land emergencies.

**12.11.2** Many transport category aircraft not engaged in intercontinental overwater flights are equipped only with flotation-type seat cushions as emergency flotation devices. Survivability of passengers using this equipment is limited. Survivors are susceptible to hypothermia in water below 21°C (70°F) and ingestion of vapors from floating fuel. Rapid response is extremely important.

**12.11.3** In water landing accidents, the possibility of fire is normally reduced because of the cooling of the heated surfaces by the water. In situations where fire occurs, chances of its control and extinguishment are minimal unless the accident occurs within close proximity to shore and extinguishing operations can take place at close range.

**12.11.3.1** Airport runways located within one-half mile of large bodies of water should ensure immediate access is available, that is, wide service roads able to handle ARFF vehicles, and boat ramps capable of rapidly deploying rescue boats. Blow-up tents, or other types of emergency shelters, should be available for emergency workers and survivors in areas where there may be inclement weather conditions.

**12.11.4** Where the distance offshore is within range, fire hose can sometimes be floated into position by scuba divers or boats and used to supplement other means of fire attack.

**12.11.5** The impact of an aircraft into water can rupture fuel tanks and lines. It is reasonable to assume that fuel is floating on the water surface. Watercraft having exhausts at or above the waterline can present an ignition hazard and should not enter the area. Advantage should be taken of wind and water currents when dealing with floating fuel. Every effort should be made to keep it from moving into areas where it would be hazardous to rescue operations. As soon as possible, pockets of fuel should either be broken up, moved away with large velocity nozzles, covered with foam, or disposed of by commercial reclaiming enterprises. The local water pollution control agency can be of assistance during this operation.

**12.11.6** If fuel on the water has ignited, approach should be made from the direction where wind direction and velocity, water current, and site accessibility create an advantage. Fire can be moved away from an area by using a sweeping technique with hose streams. Foam and other extinguishing agents can be used where practical and necessary.

**12.11.7** Scuba diving units should be dispatched to the scene of an aircraft accident in the water. Helicopters can be used to expedite the transportation of divers to the actual area of the accident. All divers who might be called for this type of service should be qualified in both scuba diving and underwater search and recovery techniques.

**12.11.8** In all operations where divers are in the water, standard diver's flags should be flown and all watercraft restricted from the diving area.

**12.11.9** Victims in the water are more apt to be found downwind or downstream. Where only the approximate location of the impact site is known upon arrival, divers should use standard underwater search patterns marking the locations of major parts of the aircraft with marker buoys. If sufficient divers are not available, dragging operations should be conducted from surface craft. In no instance should dragging and diving operations be conducted simultaneously.

**12.11.10** Life sustaining air can remain in large, submerged, occupied sections of the aircraft. As soon as practicable, entry by divers should be made carefully at the deepest point possible.

**12.11.11** Where occupied sections of the aircraft are found floating, great care should be exercised not to disturb their buoyancy, and supplemental floating devices should be attached. Removal of any occupants should be accomplished as smoothly and quickly as possible. Any shift in weight or lapse in time can result in the section sinking. Rescuers should use caution so that they are not injured or trapped should the section capsize or sink.

**12.11.12** A command post should be established on an adjacent shore to facilitate implementation of the airport/community emergency plan. (*See NFPA 424, Guide for Airport/Community Emergency Planning.*)

## Chapter 13 Post-Aircraft Accident Procedures

### 13.1 General.

**13.1.1** Many local statutes stipulate that it is the duty of the fire department to protect life and property from fire and to extinguish all destructive fires. They further state that no person has the right to interfere or hinder the fire department in the performance of this responsibility. It is vital that the area of an accident site be identified and sealed off as soon as possible; only persons required for the rescue and fire fighting should be allowed access to the wreckage, thus protecting vital evidence from being destroyed by well intentioned persons. The investigating authority will require detailed information from ARFF personnel where, in the execution of their duty, wreckage, switches, or other parts of the aircraft were moved for rescue purposes (*see 7.1.2*).

**13.1.2** During post-aircraft accident operations, a reassessment of the potential risks to personnel and the environment should be undertaken, and subsequent control measures put into operation to ensure the safety of all agencies working on site.

**13.1.3** It is essential that personnel are aware of the possibility of the ignition of fuels, any source of ignition should be prohibited at the accident site, for example, smoking and so on. It is of paramount importance when using equipment that may produce a source of ignition, adequate control measures are put into place before use. Procedures should be implemented to ensure that PPE is worn (with full-body and respiratory protection if required due to the presence of man-made mineral fibres, *see 8.2.6.2*) and that “no drinking, no eating” is enforced within the immediate accident site.

**13.1.4\*** ARFF personnel should familiarize themselves with all applicable regulations relating to movement of aircraft wreckage and disposition of accident fatalities. (*See also Annex D.*)

### 13.2 Preservation of Evidence.

**13.2.1** Following extrication of occupants from an aircraft, preservation of evidence at the site is of vital importance in determining the probable cause. ARFF personnel should be aware of this requirement, and it should be stressed in training exercises.

**13.2.2** ARFF personnel should take notice of and record the condition and position of the aircraft structure prior to beginning any significant cutting and shifting of any portions of the wreckage. If time permits, photographs should be taken of initial conditions for later study.

**13.2.3\*** The preservation of evidence also includes debris that may be scattered across the accident site, for

example, on runways or taxiways, which can include parts of the aircraft and effects belonging to passengers and crew. A large number of documents and papers may be carried by aircraft, of which recovery and preservation is vital (if the flight deck is intact then these documents should not be removed unless there is risk of loss or damage). In addition, the observations of ARFF personnel can be useful in assisting the investigating authorities.

### **13.3 Fatalities.**

**13.3.1** The location of all fatalities in and about the aircraft wreckage should be clearly identified by the use of a flag, stake, or other suitable marking and numbered to coincide with a number securely attached to the body, and photographed, if possible. Triage/medical tags can be used for this purpose. (*See also NFPA 424, Guide for Airport/Community Emergency Planning.*)

**13.3.2** Removal of fatalities remaining in an aircraft wreckage after the fire has been extinguished should be done only by, or under the direction of, the responsible medical examiner (coroner). Premature body removal can interfere with identification and destroy pathological evidence. If body removal is absolutely necessary to prevent further incineration, the original location and the body should be photographed, identified with a number, and the fact reported to investigators.

### **13.4 Preservation of Mail, Baggage, and Cargo.**

**13.4.1** The original location of mail sacks, baggage, and cargo should be observed and this information passed on to investigators. These items should be protected from further damage. If necessary, remove to a safe location such as the command post.

**13.4.2** Postal officials normally extend blanket authority to fire departments to remove mail from aircraft involved in an accident for the purpose of saving as much of it as possible. After the responding postal official has been properly identified, the ARFF officer can transfer the custody of the mail.

**13.4.3** If it is necessary to remove baggage from an aircraft involved in an accident, it should be placed in the custody of airline officials. Under certain circumstances, customs officials would be granted initial custody. Responsibility for final disposition of baggage belongs to the airline involved.

**13.4.4** Cargo manifests should be reviewed for the presence of dangerous goods. If present, they should be examined for leakage or damage to packaging. If damage has been sustained containment and decontamination procedures should be initiated immediately by qualified personnel. If cargo is removed from the aircraft, it should be held by the responsible agency.

**13.4.5** When personal property, such as jewelry, purses, watches, and so forth, is found in the vicinity of an aircraft accident, ARFF personnel should not move it but record the location and notify their incident commander, who should advise security personnel of the information. These items and their locations can be of great value to the medical examiner in making positive body identifications.

### **13.5 Flight Data and Cockpit Voice Recorders.**

Flight data and cockpit voice recorders are usually located in the aft fuselage area of most commercial aircraft and are designed to be resistant to the crash forces and fire. The outer surface is normally painted "International Orange." ARFF personnel should be able to recognize them so that they can be protected from loss or damage until accident investigators assume responsibility. Unskilled handling after a crash can cause unnecessary damage, which might lead to loss of recorded information or delay in interpretation. Although no attempt should be made to remove these recorders from the aircraft, as they could be damaged by such efforts,

if failure to remove them will result in their total loss, recovery should be made. [See Figure 13.5(a) and Figure 13.5(b).]



**FIGURE 13.5(a) Flight Data Recorder and Voice Recorder.**



**FIGURE 13.5(b) Flight Data Recorder and Voice Recorder Location.**

### **13.6 Defueling Accident Aircraft.**

**13.6.1\*** Defueling operations should be done under the direct supervision of a qualified aircraft fuel systems specialist. The defueling itself should be performed by qualified technicians using approved methods.



Provision should be made for an ARFF vehicle to stand by on-site while defueling takes place.

**13.6.2** Defueling of aircraft should not take place until there has been full consultation between the Airport Fire Service, Police, Airline, and Accident Investigation Authority. Aircraft should not be defueled during rescue operations. If there is fuel leakage, it should be dealt with in the same manner as any other fuel leak, regardless of the aircraft's attitude.

**13.6.3** Defueling an inverted aircraft has potentially very serious implications. A number of reasons why an inverted aircraft should not or cannot be defueled during the rescue operation are as follows:

- (1) Ignition can be caused by surface generated static as the fuel flows between the aircraft fuel tank and the fueling vehicle.
- (2) Due to the accident, fuel pump access doors and the fuel pumps themselves could have been damaged.
- (3) The wing attitude could make it difficult to determine in which tank the fuel is located, in what position, and in what quantity, such that while attempting to defuel, the fuel could be accidentally discharged onto the accident site.
- (4) Fueling normally involves delivery by pressure, and defueling utilizes gravity flow from underwing orifices when the aircraft is on its wheels. Inverted aircraft or those on their bellies do not offer the benefits of gravity flow. This technical problem is compounded by the fact that most fueling vehicles cannot "lift" fuel by suction in the same way as fire vehicles "lift" water from a ground level reservoir up into their water tanks.

**13.6.4\*** During defueling operations, an ignition-free area with a radius of at least 15 m (50 ft) from the outer edge of the operating area should be maintained. Persons within the controlled area should be only those necessary for the work being done. Open flames, floodlights, ground power units, and radio transmitters should be prohibited in the operating area. ARFF personnel should also be aware that their vehicles and equipment can be a source of ignition and take necessary precautions.

**13.6.5** Concurrent operations such as jacking, shifting, and removing panels should not be conducted during defueling operations. Transfer of fuel during defueling operations can cause changes in weight distribution, balance, and stability of the aircraft. Cribbing, blocking, use of air bags, and other stabilizing methods and equipment should be in place, ready for use if needed. Safe access for fueling vehicles, empty or full, should be provided.

### **13.7 Post-Accident Fuel Leaks.**

**13.7.1** To control fuel system leaks prior to completion of aircraft defueling, fuel cell sealant, clay, or other material can be used to make mini-dams on smooth surfaces to direct the flow of fuel into containers. Crimping, pegs, and plugs should also be used where appropriate. It might also be possible to shovel trenches to direct the fuel to collecting spots where it can be protected from ignition sources.

**13.7.2** Prior to moving the wreckage, the interior of the aircraft should be well ventilated to remove all flammable vapors. After removal of the aircraft, hard ground surfaces should be thoroughly cleaned to remove any flammable liquids or debris before permitting normal traffic to resume. Soft ground surfaces may be contaminated. Advice should be sought from the environmental agency as to whether removal of contaminated ground surfaces may be required.

### **13.8 Aircraft Systems Hazards.**

ARFF personnel should seek the advice of aircraft systems specialists concerning items that might present

problems during overhaul and salvage operations. Advice can include information regarding liquid or pressurized systems that need to be bled off prior to any cutting, bending, or prying around components.

## Chapter 14 Structural Fire Department Operations at ARFF Incidents

### 14.1 General.

On July 2, 1994, a DC-9 with 55 persons onboard collided with trees and a private residence near the Charlotte/Douglas International Airport, Charlotte, North Carolina. Figure 14.1(a) shows the tail section of the DC-9 lodged in the carport of a house. The nose section is in the lower left. The nose of the DC-9 sheared off on impact with trees and skidded down a residential street. [See Figure 14.1(b).]



**FIGURE 14.1(a) DC-9 Lodged in Side of a Residential Structure.**



**FIGURE 14.1(b) DC-9 on a Residential Street.**

**14.1.1** A prerequisite for the application of information contained in this chapter is a thorough review of the preceding chapters. Discussed are recommended procedures using apparatus, equipment, and resources available to most structural fire departments. Emphasis is placed on rescue of aircraft occupants.

**14.1.2** Fire control is often the means by which rescue and evacuation of aircraft occupants can be accomplished. Aircraft fuel fires require extinguishing agents and techniques common to Class B fires. Structural fire fighters, therefore, should be trained to effectively combat this type of fire utilizing available equipment and extinguishing agents. It is imperative that fire departments located near airports or aircraft flight paths be thoroughly familiar with the recommendations set forth in this guide.

**14.1.3** The recommendations presented in this chapter should not be interpreted as an alternative for adequate

airport-based rescue and fire-fighting services as outlined in NFPA 403, *Standard for Aircraft Rescue and Fire-Fighting Services at Airports*.

## **14.2 Pre-Incident Planning and Training.**

**14.2.1** Fire departments located near airports should make appropriate arrangements to participate in the airport/community emergency plan. The fire department's services should also be made available to the airport during any special events such as air shows or during periods of unusually heavy aircraft traffic. Since no community is immune to an aircraft accident, all fire departments should implement pre-incident planning and training for this type of incident.

**14.2.2** At an aircraft accident, teamwork is so important that fire department officers should review pre-incident planning as the one absolutely indispensable element in aircraft rescue and fire fighting.

**14.2.3** The psychological factors involved in aircraft rescue and fire fighting can be successfully overcome only by realistic pre-incident planning and training. Consideration should be given to conducting a critical incident stress debriefing for responding personnel. Each fire department should conduct realistic simulated aircraft fire drills using the types of extinguishing agents and equipment it expects to have available. One important training objective should be to learn the capabilities and limitations of the department's pre-incident plan procedures.

**14.2.4** Live fire training is essential in maintaining qualified and certified fire fighters. Traditionally, hydrocarbon fuel from various sources has been the fuel of choice used to conduct this training. However, with stricter environmental laws and improved technology, propane live fire simulators are in use and fulfilling training needs of the fire fighter. The size of the mock-up should come as close as possible to that of the aircraft utilizing the facility. Training should include interior, engine, wheel brake, exterior pool fire, running fuel, and three-dimensional scenarios. The propane-fired simulator should be equipped with the necessary automatic features to maximize fire fighter safety as recommended in the FAA Advisory Circular 150/5220-17A, *Design Standards for an Aircraft Rescue and Firefighting Training Facility*, Chapter 4, Mobile ARFF Training Devices.

**14.2.4.1** An aggressive attack using hose lines with spray nozzles, employing pre-incident planned operating techniques, can develop the confidence necessary to handle these types of incidents successfully.

**14.2.5** The volume of smoke, fire, and intense heat accompanying an aircraft fire can appear to be an overwhelming situation to untrained fire fighters. They might be reluctant to attack and control the fire with a limited water supply and conventional equipment for the amount of time required to complete rescue operations. Experience has proven that rescues can be accomplished even where large quantities of spilled aircraft fuel are burning.

**14.2.6** Training coordination between military, civil airport, and structural fire departments is strongly recommended. Execution of mutual aid agreements between these agencies will help ensure well-coordinated plans for rescue and fire fighting. Military air base commanders are urged to make their training facilities available to nearby fire departments, particularly where those departments are likely to be called upon to assist in rescue and fire-fighting operations.

**14.2.7** Structural fire department personnel should be thoroughly familiar with the most efficient response routes to the airport and the surrounding area. They should know all the airport's accesses and entrances and be familiar with all rules governing the operational area. This should include procedures to prevent runway incursions. A standard operating procedure for entering locked gates should be established. As a minimum, their training should include information relative to items (1) through (10) in 4.3.4 of this guide.

**14.2.8** Aircraft familiarization is also an important part of aircraft rescue and fire-fighting pre-incident planning. Structural fire departments should be provided aircraft familiarization training including hands on training, where possible. When inspecting the aircraft, the following facts should be noted:

- (1) Location of fuel, hydraulic oil, lubricating oils, and other storage locations and their capacities
- (2) Seating arrangements
- (3) Emergency exits and hatches and how to open them

Also important are the locations of batteries, oxygen storage, and various system shutoffs. (*See also 4.3.3.*)

**14.2.9** Fire departments should avail themselves of informational charts of all aircraft types using the airport. Airport fire departments as well as airlines and aircraft manufacturers can provide these charts, which depict most information pertinent to rescue and fire-fighting operations. (*See also examples of charts in NFPA Aircraft Familiarization Charts Manual.*)

**14.2.10** As a part of pre-planning, fire departments should determine that their apparatus and equipment are compatible with the airport fire department. This would include necessary couplings and connections used in water fill and transfer.

**14.2.11** Communication is critical to any mutual aid response and particularly so in the case of airport response because of the addition of operating aircraft around the scene. Pre-planning should provide knowledge of the capabilities in this area.

### **14.3 Aircraft Accident Operations.**

**14.3.1** When fire departments receive a report that an aircraft is experiencing an in-flight emergency or that it is down in the vicinity, they should immediately alert the fire forces that could be affected. Fire and police units should coordinate their efforts. Making use of a helicopter, if available, could help coordinate operations and serve as a communication link between the fire units and the control tower.

**14.3.2** Size-up (risk assessment) begins with the fire department's first notification of an incident. Multiple calls from various sources in the vicinity of the airport should alert fire dispatchers of a possible major aircraft accident and warrant an immediate first alarm response. A multiple unit response would ensure arrival at the scene of at least one unit despite the likelihood of blocked access due to debris and traffic. During the initial response, pre-incident plans should be activated, and all pertinent information should be transmitted to the responding units.

**14.3.3** The following factors are among those that are important to the size-up (risk assessment) process:

- (1) Occupant survival is generally limited to accidents where the fuselage is not severely broken up and a fire has not yet developed.
- (2) Environmental and geographical factors have a major impact on response capability. An accident in a wooded area during a winter snowstorm presents different problems than a similar accident on a clear summer afternoon.
- (3) Time of day is a factor. An aircraft accident that occurs in a shopping center parking lot has a different life hazard potential at 4:00 a.m. on Sunday than a similar event at 4:00 p.m. on Friday.
- (4) The magnitude and nature of the aircraft accident need to be considered. An aircraft accident in an open field can set off a major grass or brush fire, but an accident in a populated area can be more complex. If structures are involved, their occupancy, construction type, and stability need to be

evaluated. In addition, an assessment of damage to public utilities and their possible effect on operations should be made. Because of the possibility that water supply from hydrants might not be available due to system damage, it is good practice to include water tanks in the first response.

- (5) The nature of the aircraft operation at the time of the accident is of importance. If a crop-dusting aircraft accident occurs, steps need to be taken to protect emergency personnel and limit the spread of pesticide contamination.
- (6) Aircraft accidents that occur on takeoff usually involve large amounts of fuel. In addition to the fire problem that could evolve, steps need to be taken to prevent a fire, or fuel or fuel vapors from entering waterways, streets, and underground facilities.

**14.3.4** An arriving fire department should be governed by established response protocols.

## **14.4 Basic Fire Control.**

**14.4.1** Specific implementation of basic aircraft fire control methods should depend upon the fire-fighting equipment and types of extinguishing agents available to individual fire departments.

**14.4.2** Always assume that there are survivors of an aircraft accident until it is confirmed otherwise. In some instances, however, rescue of occupants cannot be accomplished because of the remoteness of the accident or the severity of the impact forces. In such instances, fire fighters should make a thorough search for survivors, protect any exposures, attack and extinguish the fire, and preserve the scene until the proper authorities arrive to assume responsibility.

**14.4.3** Fire fighters should have knowledge that aircraft construction differs from most other structures in ways that make fires more dangerous for the occupants and for themselves. Aircraft occupants are enclosed in a thin shell and are surrounded by large amounts of fuel with tremendous heat potential. Large aircraft have hollow wall construction with the void filled with blanket-type insulation. Present-day aircraft are constructed using a large percentage of composite materials that present unique hazards peculiar to this type of construction. Fire walls and draft stops are nonexistent except for engine, galley, and cargo bay areas. These deterrents to fire spread are not comparable to fire barriers found in building construction.

**14.4.4** In all large aircraft and in many smaller models, plumbing, electrical, heating, and cooling services are provided. Consequently there are aircraft equivalents of pipe chases, electrical load centers, busbars, and so forth. The aircraft electrical system should be treated with the same safety precautions as any other electrical installation.

**14.4.5** Most aircraft contain pressure hydraulic reservoirs and liquid or gaseous oxygen lines constructed mostly of aluminum. These, as well as brake lines, will rupture quickly under fire conditions. Fuel tanks are interconnected, and fire can propagate through ventilation ducts or manifolds. Fire impingement on empty or near empty fuel spaces often results in a violent rupture of tanks and wings.

**14.4.6** Aircraft also differ from other structures in the critical aspect of stability. Most structures are cubical in shape and will collapse in place. Aircraft are cylindrical, conical, and usually on wheels. Therefore, movement, such as tilting and rotation effects, should be considered. Guy lines, chocks, air bags, and cribbing should be required when working around damaged aircraft. Current modern aircraft can weigh 800,000 lb (363,200 kg) or more and have a height greater than a five-story building.

**14.4.6.1** Experience has shown that cribbing and shoring material should be unpainted to avoid the inherent slipperiness of painted surfaces when wet and should be made of hard wood so as not to be easily compressed. It should be available and included as a resource in the airport's emergency preparedness plan. It should be of

appropriate thickness and length to accommodate the largest aircraft scheduled into the airport. Aircraft recovery manuals should be used to ascertain appropriate cribbing sizes.

**14.4.6.2** It should be noted that the training of ARFF personnel to shore up unstable aircraft wreckage to facilitate rescue implies the provision of suitable materials. To be effective these materials must be constantly available for immediate deployment. To achieve this, the materials should be stored either in a palletized form (requiring ready access to appropriate lifting and transport equipment) or on a dedicated vehicle, such as a trailer. In either case, a designated responder should be capable of deploying these supplies at all times, under all conditions of weather, visibility, and adverse terrain.

**14.4.6.3** As an alternative to the logistics of cribbing, consideration might also be given to the deployment of earth-moving or similar heavy-duty lifting equipment, designed for off-road performance and having the weight and flexibility of electrohydraulics to support or suspend any unstable elements of a damaged aircraft. Skilled operators should also be readily available if this type of equipment is to be used at an aircraft accident site.

**14.4.6.4** Regardless of the method or equipment chosen for raising, shoring, or moving a damaged aircraft, the same requirement for guidance based on aircraft structural knowledge is required. It is important to understand that imposing loads at unsuitable locations on the aircraft could merely exacerbate the situation, promoting, rather than preventing, further disruption of the wreckage. It is advantageous for the task to be performed under the supervision of aircraft maintenance personnel, preferably those familiar with the specific type and model of aircraft involved.

## **14.5 Accidents without Fire.**

**14.5.1** When an aircraft accident occurs without fire, the following fire prevention procedures should be initiated. Hose lines should always be laid out and charged. Any spilled fuel should be covered with foam. Ignition sources such as hot aircraft components or energized electrical circuits should be eliminated. When moving wreckage, care should be taken to avoid causing sparks.

**14.5.2** When foam is not available, water spray can be used to cool hot aircraft components and to move fuel away from the fuselage. However, washing fuel away with water requires that special attention be given to exposures, low areas, and drains where fuel and vapors can flow. The fuel should be directed to an area of containment free from ignition sources where it can later be safely removed.

## **14.6 Accidents with Fire.**

**14.6.1** The location of survivors and the sources of heat or flame impingement against the aircraft will determine where hose streams should be applied first. Fire fighters should keep in mind that the heat input into the occupied portion will be reduced if the surfaces of the fuselage exposed to flame or heat can be kept wet. If the fire has penetrated the fuselage, a direct internal attack should be initiated. Care should be taken to see that water runoff does not cause the fire to spread.

**14.6.2** Normally, hose streams should be directed along the fuselage and efforts concentrated on driving the flames outward, allowing occupants to escape and permitting entry by fire fighters for rescue operations. The fuselage and fuel tank areas should be kept cool. It might be necessary to create an escape path from an exit point by “sweeping” fire out of the area with spray streams. Once an escape path has been established, it should be maintained for evacuating occupants and fire fighters performing rescue.

**14.6.3** All available hose lines should attack the fire from the same general direction. If crews are operating on opposite sides of the fuselage, they should be cautious not to push the fire toward each other. Because prompt

action is necessary to effect rescue, the first hose line in operation should be advanced immediately to keep the fuselage cool.

**14.6.4** For aircraft rescue and fire fighting, there are too many variables to establish hard and fast rules regarding use of equipment. Spray streams are normally more effective than straight streams in applying water or foam and afford much more personal protection.

**14.6.5** The number and deployment of handlines will be determined by the availability of the water, equipment, and personnel. For example, immediately upon arrival, all deployed hose lines should be charged regardless of the fire situation. However, if the apparatus is equipped with pre-connect master stream capability, the officer may choose different tactics.

**14.6.6** Fire fighters who engage in or are exposed to the hazard of proximity fire fighting should be protected in accordance with NFPA 1500, *Standard on Fire Department Occupational Safety and Health Program*.

## **14.7 Fire Fighting with Water.**

**14.7.1** If an aircraft accident occurs in a remote area with limited water available on responding apparatus, a supplemental source of water should be established. The use of tank vehicles to shuttle water between the nearest water source and the accident site should be considered.

**14.7.2** When using water to combat flammable liquid fires, nozzle pressure should be operating at approximately 100 psi (689 kPa). Spray patterns, on initial approach to the fire, should be set at a wide angle momentarily to reduce the heat and flame and then be reduced to 30 degrees to attack the fire.

**14.7.2.1** The best technique is to sweep the flame off the surface of the fuel by maintaining the lower portion of the spray pattern at the lowest level of the flame. This action also tends to cool the fuel surface and reduce vaporization. However, because there is no vapor seal provided, as when foam is used, chances for re-ignition remain, and fire fighters should take the necessary precautions to prevent re-ignition from occurring (*see Section 14.5*). Additional hose lines, used exclusively for the protection of rescue and fire-fighting personnel, are encouraged.

**14.7.2.2** Figure 14.7.2.2 shows a variety of typical spray nozzles currently used by structural fire departments. All have the feature of adjustable spray patterns and straight stream settings. Some also have variable flow settings. Most fire chiefs agree that a nozzle setting of 30 degrees provides the best pattern for fighting flammable liquid fires with either water, AFFF, or FFFP solutions.



**FIGURE 14.7.2.2 Typical Spray Nozzles.**

**14.7.3** Runoff from water streams can cause the spread of fire to exposures. Straight streams should be used when the heat is too intense to approach initially with spray streams or when the objective is to wash the burning liquid away from the fuselage to an area where there is no exposure.

**14.7.4** Trained fire fighters employing proper operating techniques can accomplish a successful rescue operation at an aircraft accident with a limited amount of water if all efforts concentrate on establishing a fire-free evacuation path. Efforts to save the aircraft hull or exposures might have to be delayed until additional resources arrive.

**14.7.5** Addition of a wetting agent might increase the effectiveness of available water; however, certain wet water additives can destroy some foams. Compatibility of the agents should be checked prior to their use.

**14.7.6** Approved portable dry chemical, foam, or halogenated agent extinguishers can be used to supplement the primary attack with hose streams. These agents are particularly effective on localized fires or in areas that cannot be readily reached by hose streams. In some instances, bulk supplies of dry chemical, foam, or halogenated agent are made available to fire departments on an emergency basis. This resource should be considered when pre-incident planning for aircraft accidents.

**14.7.7** The technique of using multiple spray nozzles with overlapping 30-degree patterns creates a continuous curtain of water spray. They should be advanced directly to the aircraft, parallel to the fuselage from either the nose or tail section, dependent on wind direction. This procedure will open an area for evacuation and rescue. If possible, hose lines should be advanced with the wind at the fire fighters' backs, as greater reach is possible with the spray streams and less heat is experienced. Progress and stream effectiveness can be monitored more easily from upwind with the smoke moving away. If there is an adequate water supply, a large spray nozzle attached to a deck gun or a portable deluge set can be used to keep the fuselage and fuel tank areas cool.

**14.7.8** Protection of exposed property should be considered whether fire exists or not. In addition to structures, exposure protection plans should include drains, sewers, waterways, power lines, and other properties where a flowing fire or unignited fuel could cause fire extension or contamination. Public utility authorities should be notified of any involvement affecting facilities under their control. Master streams from deluge sets, deck guns, or ladder pipes can be used to protect exposures if water supplies are adequate.

## **14.8 Fire-Fighting Foam.**

**14.8.1** Aqueous film forming foam (AFFF), film forming fluoroprotein foam (FFFP), or protein foam concentrates properly proportioned into fresh water are more effective than just water on flammable liquid fires.

**14.8.2** Techniques for the application of foam vary with the type used. Protein and fluoroprotein foam solutions should be applied with an aspirating foam nozzle at a pressure of 100 psi (689 kPa). A constant flow from the nozzle should be maintained to ensure an even pickup of the concentrate. The proper operating pressure should be maintained during the entire foam application for effective results. AFFF and FFFP can be applied using either an aspirating foam nozzle or a conventional spray nozzle operating at 100 psi (689 kPa).

**14.8.3** A foam/water solution using protein, fluoroprotein, or AFFF can be made up in the water tank of a structural fire-fighting apparatus for direct foam application through hose lines equipped with appropriate nozzles. After draining the appropriate amount of water from the tank, add the required amount of foam-liquid concentrate. Mix the solution by opening the "tank to pump" valve and place the pump in gear; open the "tank fill" valve slightly, and circulate the solution through the pump and tank to assure a good mix. After use, any unused solution should be drained and the entire water system should be well flushed before refilling the water tank for regular use.

**14.8.4** Some fire departments have purchased combined agent vehicles for special purposes, such as vehicle accidents and flammable liquid spills. Such combined agent vehicles are a valuable tool for the initial response



to an aircraft accident.

## 14.9 Vehicles.

Fire-fighting apparatus designed and intended for use on paved surfaces should not be used for cross-country travel. Extended hose lines from a position on a hard road surface should be used rather than risking immobilization. Once a vehicle has become immobilized, it could not be moved if it became endangered by a developing fire. It can also block or delay other emergency vehicles responding to the site.

## 14.10 Post-Accident Procedures.

Fire department personnel should be familiar with the information contained in Chapter 13 and Annex E of this guide.

# Annex A Explanatory Material

*Annex A is not a part of the recommendations of this NFPA document but is included for informational purposes only. This annex contains explanatory material, numbered to correspond with the applicable text paragraphs.*

**A.3.2.1 Approved.** The National Fire Protection Association does not approve, inspect, or certify any installations, procedures, equipment, or materials; nor does it approve or evaluate testing laboratories. In determining the acceptability of installations, procedures, equipment, or materials, the authority having jurisdiction may base acceptance on compliance with NFPA or other appropriate standards. In the absence of such standards, said authority may require evidence of proper installation, procedure, or use. The authority having jurisdiction may also refer to the listings or labeling practices of an organization that is concerned with product evaluations and is thus in a position to determine compliance with appropriate standards for the current production of listed items.

**A.3.2.2 Authority Having Jurisdiction (AHJ).** The phrase “authority having jurisdiction,” or its acronym AHJ, is used in NFPA documents in a broad manner, since jurisdictions and approval agencies vary, as do their responsibilities. Where public safety is primary, the authority having jurisdiction may be a federal, state, local, or other regional department or individual such as a fire chief; fire marshal; chief of a fire prevention bureau, labor department, or health department; building official; electrical inspector; or others having statutory authority. For insurance purposes, an insurance inspection department, rating bureau, or other insurance company representative may be the authority having jurisdiction. In many circumstances, the property owner or his or her designated agent assumes the role of the authority having jurisdiction; at government installations, the commanding officer or departmental official may be the authority having jurisdiction.

**A.3.3.60 Ignition Temperature.** Reported values are obtained under specific test conditions and may not reflect a measurement at the substances’ surface. Ignition by application of a pilot flame above the heated surface is referred to as pilot ignition temperature. Ignition without a pilot energy source has been referred to as autoignition temperature, self-ignition temperature, or spontaneous ignition temperature. The ignition temperature determined in a standard test is normally lower than the ignition temperature in an actual fire scenario.

**A.3.3.75 Protective Clothing.** Protective clothing is divided into four types as follows:

- (1) Structural fire-fighting protective clothing

- (2) Chemical protective clothing
  - (a) Liquid splash-protective clothing
  - (b) Vapor-protective clothing
- (3) High temperature-protective clothing

**A.4.2.2** When creating the response roadways from the firehouse to the incident area(s), the airport designer should consider the information in Table A.4.2.2(a) and Table A.4.2.2(b) when sizing the radius of curves. ARFF vehicles accelerate much faster than over-the-road vehicles and are capable of obtaining higher speeds in a short distance.

**Table A.4.2.2(a) Vehicle Speed over Distance from a Standing Start**

Distance Traveled from a Standing Start of the Vehicle		Speed of Vehicle at the Given Distance			
		Vehicle Water Tank Capacity ≥ 227 to ≤ 1999 L ≥ 60 to ≤ 528 gal		Vehicle Water Tank Capacity >1999 to ≤ 6000 L >528 to ≤ 1585 gal	
m	ft	kph	mph	kph	mph
30.5	100	29.0	18	32.2	20
76.2	250	40.2	25	48.3	30
152.4	500	48.3	30	64.4	40
228.6	750	64.4	40	72.4	45
304.8	1000	72.4	45	80.5	50

**Table A.4.2.2(b) Minimum Radius of a Curve Based on Speed**

Speed		Minimum Radius of a Curve with a 0.04 Superelevation (Almost Flat)*	
kph	mph	m	ft
32.2	20	39.6	130
48.3	30	92.0	302
64.4	40	174.6	573
80.5	50	291.1	955
88.5	55	436.5	1432
96.6	60	498.9	1637

\*Values were extracted from “A Policy on Geometric Design of Highways and Streets,” 1990 edition.

**A.6.2.2** Previous editions of the document used the following alerts:

- (1) Local Standby Alert was Alert I
- (2) Full Emergency Alert was Alert II
- (3) Aircraft Accident Alert was Alert III

**A.8.3.5** For more information on the physical properties of aviation fuels see NFPA 407, *Standard for*

*Aircraft Fuel Servicing*, Annex A.1.3, Aviation Fuel.

**A.12.8.4** Proximity to runway approach and departure corridors will require vertical clearance as well. Temporarily restricting runway thresholds may be required.

**A.13.1.4** See ICAO Annex 13 Aircraft Accident and Incident Investigation and ICAO Doc 6920 Manual of Aircraft Accident Investigation.

**A.13.2.3** These documents can include Certificate of Airworthiness, Certificate of Registration, Certificate of Maintenance, Technical Log, Load and Balance Sheets, Passenger and Flight Manifests, Crew Licenses, Navigational Log Sheets, Aircraft and Operations Manuals, Maps and Notes. Eyewitnesses' and passengers' statements will be fundamental in assisting the investigating authorities in indicating the probable cause, for example, indicating the final flight path.

**A.13.6.1** See NFPA 407, *Standard for Aircraft Fuel Servicing*; NFPA 410, *Standard on Aircraft Maintenance*; and ICAO Airport Service Manual, Part 5, Removal of Disabled Aircraft, 3rd Edition, 1996.

**A.13.6.4** ARFF personnel should be made aware that the issue of defueling an inverted aircraft has very serious potential. The common conclusion of experts in this field is, "If there is no leakage, leave it alone until the rescue operation is completed." Remember that the issue here is defueling an inverted aircraft, not fuel leakage. If there is fuel leakage, it should be dealt with in the same manner as any other fuel leak, regardless of the aircraft's attitude.

## **Annex B Air Transport of Dangerous Goods (Hazardous Materials and Restricted Articles) and Nuclear Weapons**

*This annex is not a part of the recommendations of this NFPA document but is included for informational purposes only.*

### **B.1 Commercial Air Transport of Dangerous Goods.**

The carriage in commercial transport aircraft of dangerous goods is an accepted practice and is closely controlled by national and international regulations.

**B.1.1 Definition of Dangerous Goods.** Dangerous goods include the following:

- (1) Explosives and any other article defined as a combustible liquid, corrosive material, infectious substance, flammable compressed gas, flammable liquid, flammable solid, magnetized material, nonflammable compressed gas, oxidizing material, poisonous article, radioactive material, and other restricted articles.
- (2) Some unlikely items can come under the heading of dangerous goods. For example, wheelchairs could contain wet-cell batteries, while breathing apparatus might have compressed air cylinders. It is well to be aware of hazards that might not be immediately apparent.

### **B.2 Radioactive Material.**

Radioactive materials constitute a particular hazard. They emit certain rays that can be a health hazard and that cannot be detected except by instruments. Radioactive materials transported by air fall into the following three categories:

- (1) *Category I.* Material emits minimal radiation

- (2) *Category II.* Emits more radiation and is assigned a transport index up to 1
- (3) *Category III.* Could have a transport index of 1.1, up to a maximum of 10

### **B.3 Transport Index.**

**B.3.1** The transport index for a package of radioactive material is a simplified expression of the maximum amount of radiation emitted, in millirem per hour, measured one meter from the surface of the package; this number should appear on the notification and such notification received by the pilot-in-command. The sum of the transport indexes is the primary concern, along with the stowage of the packages, to ensure that no living beings are exposed to hazardous radiation.

NOTE 1: In the United States, dangerous goods are transported by air, under authority of the 49 CFR 175, "Transportation," published by the Office of the Federal Register National Archives and Records Service, General Services Administration, Washington, DC 20408.

NOTE 2: The International Air Transport Association has issued the *IATA Restricted Articles Regulations*, which is available from IATA Headquarters, Montreal, Canada. Also, the International Civil Aviation Organization has developed technical instructions for the safe transportation of dangerous goods by air (document 9284-AN/905) available from ICAO, 1000 Sherbrooke Street West, Montreal, Quebec, Canada, H3A 2R2.

**B.3.2** Dangerous goods are regularly being carried on commercial transport aircraft. This includes passenger aircraft, passenger cargo aircraft (COMBI), and cargo aircraft. While the packaging requirements used to transport these materials are designed for proper containment, the possibility of breakage cannot be overlooked. This introduces the hazards of leaking flammable liquids and poisons, or radioactive contamination at an accident site. By knowing and recognizing dangerous goods labels, fire fighters can be alerted to these hazards.

### **B.4 Dangerous Goods Warning Labels.**

**B.4.1** The following dangerous goods warning labels are authorized by the U.S. Department of Transportation based on the United Nations labeling system and are authorized for domestic and foreign shipments. (*See Figure B.4.1.*) Shippers must furnish and attach an appropriate label(s) to each package of dangerous goods being offered for shipment by air. If the material in a package has more than one danger classification, one of which is Class A poison, or radioactive materials, the package must be labeled for each danger. When two or more dangerous goods of different classes are packed within the same packaging or outer enclosure, the outside of the package must be labeled for each material involved. Radioactive materials requiring labeling must be labeled on two opposite sides of the package and indicate the transport index.

**Dangerous Goods Class Numbers.** Dangerous goods are classified by the UN, ICAO, IATA, and the U.S. DOT as follows:

- (1) *Class 1.* Explosives.
- (2) *Class 2.* Gases: compressed, liquefied, dissolved under pressure, or deeply refrigerated.
- (3) *Class 3.* Flammable liquids.
- (4) *Class 4.* Flammable solids: substances susceptible to spontaneous combustion; substances that, on contact with water, emit flammable gases.
- (5) *Class 5.* Oxidizing substances: organic peroxides.

- (6) *Class 6.* Poisonous (toxic) and infectious substances.
- (7) *Class 7.* Radioactive materials.
- (8) *Class 8.* Corrosives.
- (9) *Class 9.* Miscellaneous dangerous goods (including magnetized materials, articles liable to damage aircraft structures, and articles possessing other inherent characteristics that make them unsuitable for air carriage unless properly prepared for shipment).

The bottom half of the DOT diamond-shaped labels can be printed in the language of the country of origin.

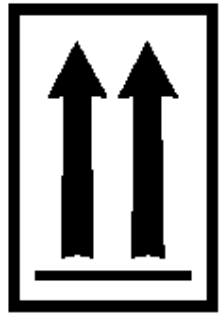

## FIGURE B.4.1 Warning Labels.

**B.4.2** The pilot in command of an aircraft should be provided with all relevant information regarding dangerous goods onboard the aircraft, and, in the event of an incident, this information should be obtained by airport emergency services either directly from the pilot or through the operations office.

**B.4.3** The NFPA publication, *Fire Protection Guide on Hazardous Materials*, provides essential information for those confronted with emergencies such as fire, accidental spills, and aircraft accidents. With the urgency of prompt identification in mind, this guide has been arranged so that the user can get to the information with a minimum of delay.

### **B.5 Incidents or Accidents Involving Radioactive Materials.**

**B.5.1** Radioactive materials carried in commercial transport aircraft are packed in rugged containers of varying sizes, such as steel drums, wooden containers, heavy corrugated cardboard, or lead boxes. In the event of an aircraft accident, the possibility of these containers breaking should always be considered.

**B.5.2** This introduces the hazard of radioactive contamination of an accident site. The following procedures should then be followed in the United States (similar procedures are followed in other countries):

- (1) Notify the nearest Department of Energy office or military base (if military aircraft is involved) of the accident immediately. They in turn will respond with a radiological team to the accident scene.
- (2) Restrict the public to as far away from the scene as possible. Souvenir collectors should be forbidden in all accidents.
- (3) Segregate fire fighters who have had possible contact with radioactive material until they have been examined further by competent authorities.
- (4) Remove injured from the area of the accident with as little physical contact as possible and hold them at a transfer point. Take any measure necessary to save lives, but carry out minimal (no more than necessary) first aid and surgical procedures until help is obtained from the radiological team physicians or other physicians familiar with radiation medicine. Whenever recommended by a doctor, an injured individual should be removed to a hospital or office for treatment, but the doctor or hospital should be informed when there is reason to suspect that the injured individual's body or clothing has been contaminated with radiation.
- (5) In accidents involving fire, fight fires upwind as far as possible, keeping out of any smoke, fumes, or dust arising from the accident. Handle this as a fire involving toxic chemicals (using positive pressure self-contained breathing apparatus and full-protective clothing). Do not handle suspected material until it has been monitored and released by monitoring personnel. Segregate all clothing and tools used at the fire until they can be checked by the radiological emergency team.
- (6) Do not eat, drink, or smoke in the area. Do not use food or drinking water that might have been in contact with material from the accident.
- (7) The use of instruments such as Geiger counters, ionization chambers, dosimeters, and so forth, is the only accurate means of determining if radioactive contamination is being given off.
- (8) To the extent possible, runoff water and other agents used in fire fighting and cleaning should be channeled, collected, and dammed to prevent entry into watercourses and the possible spread of contamination.

## **B.6 Military Aircraft Carrying Weapons.**

**B.6.1** While most military aircraft will attempt to return to a military airbase in case of emergency, this is sometimes impossible, and landings are frequently made at nonmilitary airports. There are also many cases where “joint-use” airports serve both the military and civil aircraft operations. For these reasons, it is advisable for aircraft rescue and fire-fighting crews to be familiar with the various types of military aircraft operating in the area. For this purpose, training visits to promote knowledge of the special features of military aircraft at nearby military installations are of value. Such liaison is encouraged by the military.

**B.6.2** Any person receiving information of a military aircraft accident should immediately notify the base operations office at the nearest military establishment giving all relevant information. Telephone numbers of such military installations should be kept on hand at civil airports, nearby municipal fire stations, and in airport control towers.

**B.6.3** Care should be exercised by the rescue and fire-fighting crews when approaching any military aircraft involved in fire. Armament, ejection seats, or hazardous or other dangerous cargoes can present severe hazards during such operation.

**B.6.4** The possibility of an atomic explosion from the detonation of a nuclear weapon or warhead involved in a fire, inadvertent release, or impact accident is so small it is practically nonexistent. Safety features and devices have been carefully designed and incorporated in nuclear weapons and warheads to make this assurance possible. The danger of a nuclear weapon is from the high explosives (HE) used plus radiation from the components.

**B.6.5** The presence of nuclear weapons in aircraft generally creates no greater hazard than does the presence of conventional high explosives. Most weapons contain a high explosive that could detonate upon moderate to severe impact or when subject to fire. In fact, exposure to heat can make the high explosive more sensitive. In nuclear weapons, the amount of high explosive is considerably less than that found in conventional high explosive bombs. Chemical or radiological hazard might exist during and after an accident or in a fire where a nuclear weapon is involved.

**B.6.6** Basically, the same techniques are used for fighting aircraft fires involving nuclear weapons as are those in which conventional high explosive bombs are involved; special extinguishing agents are not required to control and extinguish such fires. The brief amount of time available to control or extinguish the fire before an explosion might be expected is the only special factor to be considered.

## **B.7 Description.**

In general, nuclear weapons resemble conventional bombs in that they are enclosed in a shell or casing that is generally cylindrical in shape with tail fins. The weapon or warhead casings are of various thicknesses and might break up upon impact. Most weapons contain a conventional type of high explosive that can detonate upon moderate to severe impact or when subject to fire. The quantity of high explosives involved in a detonation can vary from a small amount to several hundred pounds and constitutes the major hazard in such an accident. If the casing breaks upon impact, the exposed and unconfined pieces of high explosive can ignite and burn or might explode if stepped on or run over. Some minor radiological hazards might exist regardless of the type of weapon, if the weapon burns or if detonation of a high explosive occurs.

## **B.8 Time Factors.**

The length of time available to safely fight a fire involving nuclear weapons depends largely upon the physical characteristics of the weapon or warhead case, the intensity of the fire, and the proximity of the fire. Since



weapon and warhead cases vary in thickness, fire-fighting time factors range from 3 minutes to an indefinite period if the fire impact incident does not detonate the high explosive immediately. The time element for each type of nuclear weapon or component is an important factor in fighting these fires. As soon as fire envelops the weapon area these time factors become effective. For weapons or warheads within a fire impact incident area, and subject to extreme heat but not enveloped in flames, a time factor of 15 minutes will apply; if the fire-fighting time factor is unknown to the fire fighters, the minimum time factor of 3 minutes should be observed. Military flight communications procedures normally provide for notification to control towers of pertinent information regarding such time factors. When a weapon or warhead has been involved in a fire and its time factor has expired, even though the fire has been extinguished or burned out, safe evacuation distances should be observed until the arrival of authorized explosive ordinance disposal personnel.

### **B.9 High Explosive Blast and Fragmentation.**

The radius of a high explosive blast from a weapon varies, depending on the amount of high explosive that actually detonates. High explosive blast fragmentation distances for these weapons range from a minimum radius of 400 ft (122 m) to a maximum of 1000 ft (305 m). Personnel within these areas can be seriously injured from blast or fragmentation upon detonation of the high explosive. These areas and distances should be considered during the initial fire department approach to an accident where weapons have been enveloped in flames for a period approximating or exceeding the weapon time factor limitations. All except experienced fire-fighting personnel should immediately evacuate to a minimum distance of 1500 ft (450 m) for protection against blast or fragmentation.

### **B.10 Precautionary Measures.**

Under no circumstances should any high explosive material from ruptured weapons that have been exposed to fire (or any components that have been scattered) be handled, stepped on, driven over, or disturbed in any manner. This material is extremely sensitive to minor detonations from shock or impact and can cause serious injury. Protective clothing and positive pressure self-contained breathing apparatus should be worn during fire-fighting operations to provide the fire fighter maximum protection from any chemical or minor radiological hazards that are present. Additional protection is afforded by fighting any fire from an upwind position. All exposed clothing, apparatus, and equipment used during a fire or impact incident where nuclear weapons or components have been involved should be monitored for possible radiological contamination by specialized recovery personnel equipped for this purpose.

### **B.11 Associated Hazards.**

Some possible hazards are as follows:

- (1) *Radiological.* In the event of a high explosive detonation or burning of a weapon, one has to be concerned principally with alpha-emitting contamination, which is serious only when ingested. Other types of radiation, which are harmless at the low levels produced in a weapon, can be detected with the use of sensitive detection instruments. (The effect of this radiation can be likened to the effects of radiation emanating from a luminous dial wristwatch.) Since alpha-emitting particles are so fine that they can be carried as smoke or dust from the burning or high explosive detonation of a nuclear weapon, some alpha-emitting contamination should be expected in the immediate accident area and downwind. Although this material can present a minor radiation problem, danger from these particles exists only when they are inhaled in significant amounts. Protection against the highest alpha levels that could be expected from such burning or high explosive detonation incidents is afforded fire-fighting personnel by the prescribed protective clothing and self-contained breathing apparatus.

- (2) *Fire.* Hazards associated with the burning of nuclear weapons and components are generally the same as those presented by conventional high explosives.
- (3) *Impact.* Weapons or warheads can break up, and the high explosive can detonate from impact. Detonation and breakup are contingent to a large degree upon the characteristics of the weapon or warhead case, the impact velocity, and the location of aircraft suspension devices.
- (4) *Sympathetic Detonation.* Detonation of a weapon or warhead, by fire or by impact, is also likely to induce detonation (nonnuclear) of any other weapon or warhead in the open within a 15 m to 90 m (50 ft to 300 ft) radius of the incident area.
- (5) *High Explosive Burning Characteristics.* Flame and smoke characteristics of burning high explosives vary and provide no specific pattern upon which to determine when the high explosive is about to detonate. Burning high explosives produce flames of various colors; they can be bright red, yellow, greenish-white, or combinations of no predominant color. Some give off a white smoke, while others burn with no trace of smoke.

## Annex C Specialized Vehicles and Equipment

*This annex is not a part of the recommendations of this NFPA document but is included for informational purposes only.*

### C.1 Hovercraft.

The hovercraft in Figure C.1 is typical of many designs available. They are easily operated and maintained with minimum training and can traverse a variety of surfaces such as water, tidal flats, snow, and ice. Payloads of 2000 lb (908 kg) permit up to 20 life rafts to be carried on this model. Piston engine operation offers a unique rescue vehicle at a fraction of the cost of a helicopter.



**FIGURE C.1 Hovercraft.**

### C.2 Elevated Platform.

Elevated platform vehicles (*see Figure C.2*) can provide valuable assistance when emergencies involve “wide-body” style aircraft. When fires occur in the tail section engine of this type of aircraft, fire fighters can be positioned to permit proper application of extinguishing agent on the fire.



**FIGURE C.2 Elevated Platform Vehicle.**

## **Annex D Driver's Enhanced Vision System: A Technical Approach for Aircraft Rescue and Fire-Fighting Services**

*This annex is not a part of the recommendations of this NFPA document but is included for informational purposes only.*

### **D.1 Introduction.**

Several accidents have occurred in poor visibility conditions, and, with the proliferation of category IIIC landing systems, more requirements for fire fighting in low visibility conditions can be expected. Aircraft rescue and fire-fighting services currently have no reliable way to locate and navigate crash sites at airports under conditions of poor visibility.

### **D.2 Background.**

Aircraft rescue and fire-fighting services are required to demonstrate an ability to respond anywhere on the airport operational runway areas as part of earning their annual certificate. This response requirement is considered vital to the ability of ARFF services to gain control of a rapidly growing external post-crash fuel fire and their ability to protect the evacuating passengers from the aircraft fuselage. A response in 3 minutes is dependent on the vehicle's ability to accelerate rapidly from the rescue service's facilities and to maintain approximately a 50-mph (80.5-km/h) approach to the accident site. Accomplishing this task under substandard visibility conditions such as fog and rain prevents the responding vehicles from reaching this speed.

There is a clear need to provide operational equipment in the rescue vehicles that maintains their response ability if low visibility flight operations are to be conducted.

The problem of poor visibility response at airports for rescue and fire-fighting services can be broken down into the following three components:

- (1) Locating the accident sites
- (2) Navigating aircraft rescue and fire-fighting vehicles to crash sites
- (3) Negotiating terrain and obstacles in low visibility conditions

Airport fire services need a driver's enhanced vision system (DEVS) that addresses these three components.

Aircraft rescue and fire-fighting services should obtain an accurate position fix on the crash site within a time parameter that is comparable to their response time (under 3 minutes). The current system for locating crash sites that are not visible to aircraft rescue and fire-fighting services relies on visual observations, estimates, and verbal descriptions of airport landmarks provided by air traffic controllers. This system is prone to human error. The optimal solution to this problem is a system that locates a crash site on a digital map of the airport automatically and transmits this location to aircraft rescue and fire-fighting services.

Navigation of aircraft rescue and fire-fighting vehicles to crash sites is an issue that can be solved with today's technology. Sophisticated radio navigation systems such as the global positioning system (GPS) provide precise positioning capability. This position information, combined with digital maps of the airport area, can be displayed on a geographic map or heads-up display (HUD) to guide the crews.

Negotiating terrain and locating obstacles in low visibility conditions is an important capability that aircraft rescue and fire-fighting services currently do not possess. The only aids that rescue services currently use for improving vision under poor visibility conditions are windshield wipers and headlights. These devices often do not improve visibility enough to allow rescue teams to drive safely at the high speeds necessary to reach a crash site within a reasonable time. One aid that would provide improvement is a forward looking infrared device (FLIR). FLIRs currently are used by the military to improve visibility at night and during severe weather conditions. The FLIR system needs to be fully functional as soon as the fire equipment departs the fire station facility. Exit time typically is under 30 seconds from the time of accident notification. On-line and operational equipment should in no way impede the ability of the aircraft rescue and fire-fighting services to respond. Equipment is to be automated and is to necessitate little attention by the truck operator.

### **D.3 General Requirements.**

A driver's enhanced vision system (DEVS) is required in an aircraft rescue and fire-fighting vehicle for airport emergency equipment. It facilitates faster and safer travel to emergency situations at night and in adverse weather conditions. It provides a substantial increase in the ability to locate people, other aircraft, vehicles, and debris at the emergency site. Its ability to allow the driver to see through flames, smoke, and fog during both the day and night provides ARFF vehicles with a significant increase in effectiveness in every phase of emergency operations.

The DEVS requires a transparent window display (TWD), which is often called a heads-up display (HUD), combined with a global positioning system (GPS) and geographic information system (GIS), on-board sensors, a central data and command RF link (radio communications), and a forward looking infrared (FLIR) sensor. These elements are to be integrated into a single functional system. A validation demonstration program is necessary to provide the quantitative information needed to justify the DEVS and refine it for the ARFF services application.

### **D.4 Operating Scenarios and Capabilities — Mission Description.**

From the moment that an alert is received until the end of the emergency, the ARFF services mission is subject to stress and uncertainty. At any given moment, day or night, the equipment needs to be fully functional within a few seconds, regardless of adverse weather. Often vehicles and aircraft are positioned on the runways and taxiways in unusual or unexpected locations. In the event of an aircraft accident, victims and debris can be present anywhere on the airport. At the same time, the large size of modern airports, with multiple parallel runways and taxiways, places a priority on the ability to travel at high speed to the emergency site.

Once ARFF services have arrived at the location, the ability to assess the situation is crucial to carrying out the

mission. The information available to the vehicle operator contributes directly to the level of performance of the ARFF mission. This information needs to be obtained without any increase in the workload. The DEVS reduces the impact of night conditions, adverse weather, fire, and smoke so that the operator's performance approaches that achieved during the optimum daylight scenario.

To achieve this goal, information is to be provided in an easily recognizable form, without the need for vehicle operator intervention. Rescue vehicle location, the location of the emergency, the location of other vehicles (ground and aircraft), the location of people, and the location of debris are the basic data needed (and normally available during the least difficult situations). The condition of the aircraft, location of victims, presence and location of spilled burning fuel, and location of other ARFF personnel also are crucial. In addition, the possible presence of toxic gases caused by spilled or burning cargo needs to be determined to provide for a safe response to the situation. Finally, since multiple vehicles and ARFF crews are always involved in most emergency situations, a centralized command and control system is needed to coordinate the activities of all elements of the emergency response team. The DEVS is one element of this command and control system.

### **D.5 Required Capabilities.**

The DEVS provides an increase in the knowledge available to the emergency crew. The crew are able to see through fog, rain, sleet, and snow. The crew are able to see through smoke and flames in and around the burning aircraft, to detect the position of evacuees and trapped passengers, and to distinguish them among the debris and to move into a position for fire fighting. They are able to apply extinguishing agents to the hottest areas of the burning fire more precisely. They also can track other fire fighters through the smoke and fire while rescue efforts are under way.

The FLIR device provides the ARFF operator with the ability to detect debris and other vehicles (stationary or moving) in the vicinity, as well as to detect passengers evacuating from the aircraft. The FLIR detector can illuminate humans in a smoke or fog environment where normal vision is inadequate. The FLIR stores information for normal driving conditions. The FLIR uses the brighter-than-background standard runway and taxiway lights, which are detectable as it travels to the site.

### **D.6 System Elements.**

The elements of the DEVS for the ARFF vehicle demonstration include a forward looking infrared device (FLIR), a transparent window display (TWD) or heads-up display (HUD), and a global positioning system (GPS) with geographic information system (GIS) or mapping.

### **D.7 Forward Looking Infrared Device.**

The FLIR is a high resolution infrared detector. It is enhanced with wide dynamic range processing for increased penetration of smoke and fog. The FLIR contains a two-dimensional focal plane array using platinum silicide as the detector material. It operates at wavelengths from 8 micrometers to 12 micrometers and has a sensitivity of 32.2°F (0.1°C). An alternate FLIR of 3 micrometers to 5 micrometers with similar sensitivity also is implemented to establish whether the shorter wavelength provides significant benefits in the smoke environment. A key element in the use of the FLIR device for this application includes a total hands-off automation philosophy. Rapid cool-down is another function dictated by the nature of FLIR detectors. To achieve the best performance, these detectors should be cooled to very low temperatures [in the range of -270°C (-454°F)]. The cooling systems that have been developed have an operating life of about 2500 hours. Rapid cool-down or extended standby life cycle is considered essential to an ARFF application. Zero (0) or near-zero time start-up is an operational requirement for effectiveness.

## **D.8 Dynamic Range Issues.**

To detect people and debris, the FLIR has a sensitivity of approximately 32.2°F (0.1°C). At the same time, the FLIR can be expected to deliver this sensitivity in the presence of flames that could reach temperatures of 1000°C (1832°F). In order to accomplish this, the FLIR operates over an instantaneous dynamic range of about 10,000:1.

## **D.9 Transparent Window Display.**

The transparent window display system hardware consists of a projector, an optical element, and a symbol generator to provide information to an operational position. The symbol generator provides data to the projector by means of dedicated signal cables. The symbol generator has the capability to receive and to process data links from up to six video inputs and two serial inputs while formatting messages based on a control program. The control program uses the data's priority, refresh rate, and other site-specific criteria to implement the sequence and content of the information presentation.

## **D.10 Projector.**

The DEVS projector is a high-brightness CRT, monochrome emitter that creates and projects a focused image onto the window of the ARFF vehicle. The projector is designed to be placed 60 in. to 72 in. (152.4 cm to 182.9 cm) from the window. There are optional mounting schemes that allow the projector to be mounted off-axis from the window to accommodate existing mechanical obstructions. The projector is to be equipped to accept standard signal inputs that include RS-170 to utilize the TWDs as a simple replacement of an existing heads-down display (HDD).

## **D.11 Optical Element.**

The optical element is mounted to the window of the ARFF vehicle to act as a dynamic display surface within the truck cab. The optical element should be 6 in.<sup>2</sup> to 12 in.<sup>2</sup> (38.7 cm<sup>2</sup> to 77.4 cm<sup>2</sup>) and affixed to a selected location on the window with room temperature vulcanizing material. The location should be predefined to reflect data in a uniform manner that is specified by both lateral and vertical angles perpendicular to the plane of the window. The viewing zone should offer a lateral reflection angle of 30 degrees and a vertical reflection angle of 15 degrees. The information is to be presented in a bright green color and is to be focused at the plane of the window. The DEVS is not to obstruct the view to the outside of the vehicle.

## **D.12 Symbol Generator.**

The symbol generator is to be a microcomputer-based system designed for rack mounting in an equipment bay. This remote computer offers the capability to interface directly with a selected set of onboard data channels or discrete indicator inputs and is linked with a GPS tracker and a FLIR. The symbol generator is programmed with the mission-specific control scheme and operates in an automatic mode. There is a keyboard and monitor option that supports on-site changes of the data communications and control routines. The symbol generator formats data "pages" and routes this information to the appropriate projector based on priority or currency or on demand. The symbol generator is capable of being configured to accept a variety of standard signal inputs including RS-232, RS-422, and RS-170.

## **D.13 Global Positioning System.**

A global positioning system (GPS) receiver is to be mounted on the ARFF vehicle and interfaced with the transparent window display system for display of position information. The GPS is to be a six-channel receiver

capable of tracking up to eight satellites. The GPS receiver calculates new position data once every second. Position accuracy is specified at a maximum of 25 m (82 ft), with a typical accuracy of about 10 m to 15 m (32.8 ft to 49.2 ft). An additional ground-based differential transmitter on the airfield provides accuracy from 1 m to 3 m (3.3 ft to 9.8 ft).

#### **D.14 Geographic Information System.**

The airport mapping system by which the ARFF vehicle is navigated can be developed by several methods. One method being considered is the digital reconstructive method. This is accomplished by taking an aerial photograph of the airport and digitizing it so it then can be displayed on the computer screen for mapping. This method, as it is developed, could provide the increased local terrain and hazards definition needed by the ARFF vehicle to travel on and around the airfield. Additional mapping capability with definitions of 1.6 m, 4.8 m, and 16.1 m (1 mi, 3 mi, and 10 mi) provide for call-up mapping in the event of an accident off-airport operational areas. Digital aerial mapping is an emerging technology that provides three-dimensional hazard definition of streams, swales, and drainage culverts, as well as other hazards that could impede the progress of the rescue.

#### **D.15 Computer Information Enhancements.**

Once an operational computer is placed in the ARFF vehicle, it provides a host of other fire-fighting capabilities. Fire fighters are able to have the complete airport's emergency plan available in the computer with menu-driven software. Toxic and hazardous material indexes can be provided. Complete instructions on emergency door and entryway door operations for every type of commercial aircraft can be provided.

#### **D.16 Vehicle Electrical Upgrade.**

Because of the need for better power sources, vehicles with new technology equipment need to undergo some modifications to the existing electrical systems. Computers and electronically controlled devices need smooth-filtered and stable voltage sources. The equipment targeted for installation is modified to operate in the voltage ranges used on the existing vehicles. This usually is 12 V or 24 V dc. Special power converters and voltage stabilizers are to be considered. There also are requirements for the addition of 115 V ac in some cases. Operating off portable generator power sources that might already exist on some of these vehicles does not, in most cases, provide the smooth, stabilized power sources of these requirements. Transformer rectifiers and power converters do not provide a major challenge for the technological requirements of this program. Low-cost portable battery back-up systems also should be considered to provide power for start-up of the vehicle as well as accidental shutoff of the vehicle system supply. The cost for these required voltage sources is minimal when compared to the trouble-free environment that they provide for the electronic boards and computer systems.

#### **D.17 Final Assessment.**

The object of this assessment program is to provide information about the new computer-based equipment and vision enhancement devices that help the airport rescue services perform their assigned mission under suboptimal visibility conditions. The cost of installing this equipment can be justified by the need to operate aircraft under these poor visibility conditions. If operations are conducted that allow the aircraft to take off and land under poor visibility conditions, it is reasonable to expect that additional requirements for fire-fighting response under low visibility conditions will be established.

The technology needed to perform the driver's enhanced vision system (DEVS) is available now. Although the equipment can be bought off the shelf, installation necessitates some additional research effort because aircraft

rescue and fire-fighting mission requirements were not considered in the research efforts that produced this technology. In each case, the individual elements of the DEVS considered the fact that the proposed system should require low operational workload by the operator. Each piece of the system endeavors to use current technological equipment with some hardware and software modifications. Finally, the DEVS should be designed for easy installation and a maintenance-free duty life cycle or at the least a modular rack installation design allowing the removal and replacement of components by current maintenance personnel without adding to the personnel burden of a rescue and fire-fighting service.

Finally, the most important issue is cost. Historically, this technology is expensive. Some of the reasons for these high costs were dictated by low production runs and the survivability conditions for which the equipment originally was designed. Equipment meeting the rigorous requirements necessary for military applications can add many thousands of dollars to the final purchase price. It is hoped that, with the careful redesign and unique adaptation of existing equipment designs and unit cost price decreases, the cost of using this technology in an aircraft rescue fire-fighting vehicle can be reduced substantially in the near future.

## **D.18 Driver's Enhanced Vision System Guidelines.**

**D.18.1 DEVS Performance Characteristics.** The driver's enhanced vision system (DEVS) is an integrated system of sensors, computers, and navigational equipment designed to improve the response and operation of ARFF crews in low visibility conditions. The DEVS consists of three components: a night or low visibility capability, a vehicle navigation capability, and a vehicle tracking capability, which are integrated using a digital radio data link.

To meet the DEVS requirements, systems need to integrate all three components cohesively. Each component should be integrated into the vehicle's normal operations through a systematic approach of understanding and adapting the technology to the needs of the fire-fighting population.

In the sections that follow, the base performance characteristics are detailed. It is important to note that technology development in the enhanced vision area is progressing rapidly; therefore, the criteria that follows should be considered minimal. Questions regarding specific production systems, new performance capabilities, or recommended systems should be directed to the FAA's airports office.

**D.18.2 Low Visibility Capability.** The intent of the low visibility capability is to provide an enhanced picture of the environmental scene through the use of a chamber or other sensor system displayed inside of the cab. For the immediate future, it appears that forward looking infrared (FLIR) technology holds the most promise for aiding visibility in smoke, fog, and haze, and at night. The minimum recommended performance characteristics of the low visibility system are provided below:

(1) *General.*

- |                                     |   |
|-------------------------------------|---|
| (a) Expected worst case visibility. | 0 ft range/0 ft ceiling   |
| (b) Time to operational.            | ≤ 30 sec  |
| (c) Detection of humans.            | 500 ft (152.4 m), temp: -20°F to 115°F (-28.9°C to 46.1°C), moving 55 mph (88.5 km/h), clear conditions     |
|                                     | 500 ft (152.4 m), temp: -20°F to 115°F (-28.9°C to 46.1°C), moving 50 mph (80.5 km/h), light fog conditions |



400 ft (121.9 m), temp: -20°F to 115°F  
(-28.9°C to 46.1°C), moving 40 mph (64.4  
km/h), heavy fog conditions

400 ft (121.9 m), temp: -20°F to 115°F  
(-28.9°C to 46.1°C), moving 40 mph (64.4  
km/h), smoke conditions

300 ft (91.4 m), temp: -20°F to 115°F  
(-28.9°C to 46.1°C), moving 35 mph (56.3  
km/h), rain/snow conditions

(d) Detection of GA aircraft. 2500 ft (762.0 m), temp: -20°F to 115°F  
(-28.9°C to 46.1°C), moving 55 mph (88.5  
km/h), clear conditions

1000 ft (304.8 m), temp: -20°F to 115°F  
(-28.9°C to 46.1°C), moving 50 mph (80.5  
km/h), light fog conditions

500 ft (152.4 m), temp: -20°F to 115°F  
(-28.9°C to 46.1°C), moving 40 mph (64.4  
km/h), heavy fog conditions

500 ft (152.4 m), temp: -20°F to 115°F  
(-28.9°C to 46.1°C), moving 40 mph (64.4  
km/h), smoke conditions

500 ft (152.4 m), temp: -20°F to 115°F  
(-28.9°C to 46.1°C), moving 35 mph (56.3  
km/h), rain/snow conditions

(e) Detection of objects near fires. People, debris, wreckage, and equipment  
within 20 ft (6.1 m) of a 6 ft (1.8 m)  
diameter Jet A fuel fire from a range of  
1000 ft (304.8 m)

(2) *FLIR Specific.*

- (a) IR waveband. Long wave IR energy (8  $\mu$ m to 12  $\mu$ m)
- (b) Video output. RS-170 or industry standard video
- (c) Gain and level controls. Automatic
- (d) Horizontal field of view.  $\geq 28$  degrees (40 degrees preferred)
- (e) Vertical field of view.  $>20$  degrees, aspect ratio to match vertical
- (f) Lens clearing capability. Windshield wiper, high pressure air, or equivalent
- (g) Temperature and humidity changes. Changes in ambient temperature and humidity should not result in condensation inside the FLIR housing or optics assembly
- (h) Mounting. On top of vehicle with pan and tilt capability, remote-control equipped, line of sight aligned with driver's line of sight
- (i) Video monitor. 8 in. to 10 in. (20.3 cm to 25.4 cm) diagonal display mounted near driver's line of sight

Alternative: Heads-up display with field-of-view to match FLIR

**D.18.3 Navigation Capability.** The intent of the navigation capability is to allow for accurate positioning of the vehicle on or around the airport surface. The navigation capability should provide a depiction of the vehicle, notable landmarks, roadways, and other guidance aids. Information should be provided to the driver in a meaningful form appropriate to the needs of the fire response.

The navigation capability consists of three main components: a global positioning system (GPS) receiver, a computer system containing supporting maps and navigation information, and a display/control system for driver information.

For full capability on the airport, the DEVS should incorporate both capabilities into the design. The performance characteristics of the components in the list in D.18.2 are as follows:

(1) <i>Position Availability.</i>	Computed position within 30 sec/hr/day, 7 days/week
(2) <i>Accuracy.</i>	Two-dimensional position within 15 ft (4.6 m)
(3) <i>Dead Reckoning.</i>	Coasting capability when satellite track is lost due to shadowing
(4) <i>Position Update Rate.</i>	< 1/sec
(5) <i>Initialization and Operation.</i>	Fully automatic
(6) <i>Map.</i>	
(a) Levels of detail.	Level 1 — Airport operations area Level 2 — Airport property boundary Level 3 — 5 mi (8 km) radius of the airport center; either variable or fixed zooms within each level should be provided
(b) Orientation.	North-up or heading-up, selectable (Note: Heading-up orientation is required for situational awareness in low visibility conditions and unfamiliar areas)
(c) Visual orientation cues.	Vehicle orientation, vehicle heading, direction of low visibility coverage
(7) <i>Driving Cues.</i>	Range/bearing indicator in line-of-sight (on FLIR display or separate)
(8) <i>Data Link.</i>	
(a) Error checking.	Standard error checking
(b) Frequency selection.	Selectable to airport location
(9) <i>Display — Color.</i>	≥ 256 colors

**D.18.4 Tracking Capability.** The tracking capability components include the following:

- (1) Differential GPS (DGPS) correction software
- (2) Data link hardware/software
- (3) Integrated display/control system for command center operations

The command center can be either fixed or mobile, depending on individual airport ARFF operations. This capability is intrinsically tied to the tracking capability, which allows for the monitoring of the positions of other vehicles, the crash site, identified victims, and other factors, as well as linkage to a centralized display for emergency coordination. The performance characteristics of the tracking capability function are as follows:

- (1) *Map — Orientation.* North-up with dynamic zoom and pan
- (2) *Data Link.*

- |                             |  |
|-----------------------------|--|
| (a) Error checking.         | Standard error checking  |
| (b) Frequency selection.    | Selectable to airport location   |
| (3) <i>Display — Color.</i> | Large high-resolution monitor [ $>19$ in. ( $>48.3$ cm) diagonal color monitor, $1280 \times 1024$ resolution] |

## D.19 Glossary of Technical Terms.

**D.19.1 Aircraft Rescue and Fire Fighting (ARFF).** Formerly known in the fire-fighting industry as crash, fire, and rescue.

**D.19.2 Cool-Down in the Operational Environment of an Infrared Detector.** Term used to describe the period of time needed for the refrigeration unit of the optical sensor to cool the unit to approximately  $-454^{\circ}\text{F}$  ( $-270.2^{\circ}\text{C}$ ) below zero (0). This cool-down mode provides the necessary sensitivity of 10,000:1 for infrared thermal detection.

**D.19.3 Driver's Enhanced Vision System (DEVS).** A vision enhancement system utilizing several electronic and computer-based components that aids in improving sight as well as movement or navigation around the airport during reduced visibility operational conditions.

**D.19.4 Forward Looking Infrared (FLIR).** A heat detector device that allows the viewer to see radiant heat projected from objects. These devices work in the micron band of the infrared spectrum (e.g.,  $8 \mu\text{m}$  to  $12 \mu\text{m}$ ).

**D.19.5 Geographic Information System (GIS).** A device that allows an aerial map of the airport to be displayed with markers that move along the image as the vehicle changes position.

**D.19.6 Global Positioning System (GPS).** A device that picks up signals from orbiting satellites and determines positions of location on earth by reference to longitude and latitude.

**D.19.7 Heads-Up Display (HUD).** The military name for a device that allows a person to look and operate a device while viewing through the cockpit window of an aircraft. This device displays information on the cockpit window.

**D.19.8 Transparent Window Display (TWD).** An electronic device that projects an image on a special coated glass or plastic that also allows the viewer to see through the clearplate with a slight reduction in visibility.

## Annex E Civil Aircraft Accident Investigation

*This annex is not a part of the recommendations of this NFPA document but is included for informational purposes only.*

### E.1

In the United States of America, major aircraft accidents are investigated by the National Transportation Safety Board (NTSB), 800 Independence Avenue SW, Washington, DC 20591. In some instances responsibility for investigation is delegated by the Board to the Federal Aviation Administration (FAA).

RESCUE: The occupants.

GUARD: The wreckage — Allow no one inside the wreckage area other than those necessary for occupant

Copyright NFPA

removal, fire fighting, and the possible removal of mail and cargo where necessary to protect it from further damage. Items removed for protection must be retained locally for examination by a Federal Air Safety Investigator.

ADVISE: The county coroner/medical examiners — Fatally injured occupants of the aircraft should be held for possible pathological or toxicological examination or both prior to embalmment.

IDENTIFY: The position of fatalities — Prior to removing the remains of fatally injured occupants, tag or otherwise identify each body, and mark its location in the wreckage or on the ground (photograph in position, if possible).

PERMIT: News media coverage — Accredited news media can be permitted to enter and photograph the area as long as the wreckage is not disturbed.

NOTIFY: The local authorities, the Safety Board, FAA.

## **E.2 National Transportation Safety Board Rules.**

*(The following material is extracted from 49 CFR 175, Chapter VIII.)*

Title 49 — Transportation

Chapter VIII — National Transportation Safety Board

Revised: March 20, 1985

Part 830 — Notification and Reporting of Aircraft Accidents or Incidents and Overdue Aircraft, and Preservation of Aircraft Wreckage, Mail, Cargo, and Records.

Subpart A — General.

Sec.

830.1 Applicability.

830.2 Definitions.

Subpart B — Initial Notification of Aircraft Accidents, Incidents, and Overdue Aircraft.

830.5 Immediate notification.

830.6 Information to be given in notification.

Subpart C — Preservation of Aircraft Wreckage, Mail, Cargo, and Records.

830.10 Preservation of aircraft wreckage, mail, cargo, and records.

Subpart D — Reporting of Aircraft Accidents, Incidents, and Overdue Aircraft.

830.15 Reports and statement to be filed.

Authority: Title VII, Federal Aviation Act of 1958, as amended, 72 Stat. 781, as amended by 76 Stat. 921 (49 U.S.C. 1441 et seq.), and the Independent Safety Board Act of 1974, Pub. L. 93-633, 88 Stat. 2166 (49 U.S.C. 1901 et seq.).

Subpart A — General.

830.1 Applicability.

Copyright NFPA

This part contains rules pertaining to:

- (1) Notification and reporting aircraft accidents and incidents and certain other occurrences in the operation of aircraft when they involve civil aircraft of the United States wherever they occur, or foreign civil aircraft when such events occur in the United States, its territories, or possessions.
- (2) Preservation of aircraft wreckage, mail, cargo, and records involving all civil aircraft in the United States, its territories or possessions.

#### 830.2 Definitions.

As used in this part the following words or phrases are defined as follows:

*Aircraft accident* means an occurrence associated with the operation of an aircraft which takes place between the time any person boards the aircraft with the intention of flight and all such persons have disembarked, and in which any person suffers death or serious injury, or in which the aircraft receives substantial damage.

*Fatal injury* means any injury which results in death within 30 days of the accident.

*Incident* means an occurrence other than an accident, associated with the operation of an aircraft, which affects or could affect the safety of operations.

*Operator* means any person who causes or authorizes the operation of an aircraft, such as the owner, lessee, or bailee of an aircraft.

*Serious injury* means any injury which:

- (1) Requires hospitalization for more than 48 hours, commencing within 7 days from the date the injury was received
- (2) Results in a fracture of any bone (except simple fractures of fingers, toes, or nose)
- (3) Causes severe hemorrhages, nerve, muscle, or tendon damage
- (4) Involves any internal organ
- (5) Involves second or third degree burns, or any burns affecting more than 5 percent of the body surface

*Substantial damage* means damage or failure which adversely affects the structural strength, performance, or flight characteristics of the aircraft, and which would normally require major repair or replacement of the affected component. Engine failure or damage limited to an engine if only one engine fails or is damaged, bent fairings or cowling, dented skin, small punctured holes in the skin or fabric, ground damage to rotor or propeller blades, and damage to landing gear, wheels, tires, flaps, engine accessories, brakes, or wingtips, are not considered *substantial damage* for the purpose of this part.

Subpart B — Initial Notification of Aircraft Accidents, Incidents, and Overdue Aircraft.

#### 830.5 Immediate notification.

The operator of an aircraft shall immediately, and by the most expeditious means available, notify the nearest National Transportation Safety Board field office<sup>1</sup> when:

<sup>1</sup>The National Transportation Safety Board field offices are listed under U. S. Government in the telephone directories in the following cities: Anchorage, AK; Atlanta, GA; Chicago, IL; Denver, CO; Fort Worth, TX; Kansas City, MO; Los Angeles, CA; Miami, FL; New York, NY; Seattle, WA.

- (1) An aircraft accident or any of the following listed incidents occur:

- (a) Flight control system malfunction or failure;
  - (b) Inability of any required flight crewmember to perform normal flight duties as a result of injury or illness;
  - (c) Failure of structural components of a turbine engine excluding compressor and turbine blades and vanes;
  - (d) In-flight fire; or
  - (e) Aircraft collide in flight.
- (2) An aircraft is overdue and is believed to have been involved in an accident.

#### 830.6 Information to be given in notification.

The notification required in section 830.5 shall contain the following information, if available:

- (1) Type, nationality, and registration marks of the aircraft;
- (2) Name of owner, and operator of the aircraft;
- (3) Name of the pilot-in-command;
- (4) Date and time of the accident;
- (5) Last point of departure and point of intended landing of the aircraft;
- (6) Position of the aircraft with reference to some easily defined geographical point;
- (7) Number of persons aboard, number killed, and number seriously injured;
- (8) Nature of the accident, the weather, and the extent of damage to the aircraft, so far as is known; and
- (9) A description of any explosives, radioactive materials, or other dangerous articles carried.

#### Subpart C — Preservation of Aircraft Wreckage, Mail, Cargo, and Records.

##### 830.10 Preservation of aircraft wreckage, mail, cargo, and records.

- (1) The operator of an aircraft involved in an accident or incident for which notification must be given is responsible for preserving to the extent possible any aircraft wreckage, cargo, and mail aboard the aircraft, and all records, including all recording mediums of flight, maintenance, and voice recorders, pertaining to the operation and maintenance of the aircraft and to the airmen until the Board takes custody thereof or a release is granted pursuant to Section 831.10(b).
- (2) Prior to the time the Board or its authorized representative takes custody of aircraft wreckage, mail, or cargo, such wreckage, mail, or cargo may not be disturbed or moved except to the extent necessary:
  - (a) To remove persons injured or trapped;
  - (b) To protect the wreckage from further damage; or
  - (c) Where it is necessary to move aircraft wreckage, mail, or cargo, sketches, descriptive notes, and photographs shall be made, if possible, of the original position and condition of the wreckage and any significant impact marks.
- (3) The operator of an aircraft involved in an accident or incident shall retain all records, reports, internal documents, and memoranda dealing with the accident or incident, until authorized by the Board to the

contrary.

## Subpart D — Reporting of Aircraft Accidents, Incidents, and Overdue Aircraft.

830-15 Reports and statements to be filed.

- (1) *Reports.* The operator of an aircraft shall file a report on Board Form 6120.1 or Board Form 6120.2<sup>2</sup> within 10 days after an accident, or after 7 days if an overdue aircraft is still missing. A report on an incident for which notification is required by Section 830.5(a) shall be filed only as requested by an authorized representative of the Board.
- (2) *Crewmember Statement.* Each crewmember, if physically able at the time the report is submitted, shall attach a statement setting forth the facts, conditions and circumstances relating to the accident or incident as they appear to him. If the crewmember is incapacitated, he shall submit the statement as soon as he is physically able.
- (3) *Where to File the Reports.* The operator of an aircraft shall file any report with the field office of the Board nearest the accident or incident.

<sup>2</sup>Forms are obtainable from the Board field offices (see footnote 1), the National Transportation Safety Board, Washington, DC 20594, and the Federal Aviation Administration, Flight Standards District Office.

NOTE: The reporting and recordkeeping requirements contained herein have been approved by the Office of Management and Budget in accordance with the Federal Report Act of 1942.

Signed at Washington, DC, on September 4, 1980.

James B. King

Chairman

## Annex F Sample Mutual Aid Agreements

*This annex is not a part of the recommendations of this NFPA document but is included for informational purposes only.*

### **F.1**

The following material is extracted from AFR 92-1.

### **F.2 USAF Mutual Aid Agreement (AFR 92-1).**

This agreement, entered into this \_\_\_\_\_ day of \_\_\_\_\_, 20\_\_\_\_, between the Secretary of the Air Force, acting pursuant to the authority of the Act of May 27, 1955 (69 stat, 66), and (fire organization) is for the purpose of securing to each the benefits of mutual aid in fire prevention, in the protection of life and property from fire, and in fire fighting.

It is agreed that:

- (1) Upon request to a representative of the \_\_\_\_\_ Air Force Base Fire Department by a representative of the (fire organization), fire fighting equipment and personnel of the \_\_\_\_\_ Air Force Base Fire Department will be dispatched to any point within the area for which the (fire organization) normally provides fire protection as designated by the representative of the (fire organization).

Copyright NFPA

- (2) Upon request to the representative of the (fire organization) by a representative of \_\_\_\_\_ Air Force Base Fire Department, fire fighting equipment and personnel of the (fire organization) will be dispatched to any point within the fire fighting jurisdiction of the \_\_\_\_\_ Air Force Base Fire Department as designated by the representative of the \_\_\_\_\_ Air Force Base Fire Department.
- (3) Any dispatch of equipment and personnel pursuant to this agreement is subject to the following conditions:
  - (a) Any request for aid hereunder shall include a statement of the amount and type of equipment and number of personnel requested, and shall specify the location to which the equipment and personnel are to be dispatched, but the amount and type of equipment and number of personnel to be furnished shall be determined by a representative of the responding organization.
  - (b) The responding organization shall report to the incident commander of the requesting organization at the location to which the equipment is dispatched and shall be subject to the orders of that official.
  - (c) A responding organization shall be released by the requesting organization when the services of the responding organization are no longer required or when the responding organization is needed within the area for which it normally provides fire protection.
  - (d) In the event of a crash of aircraft owned or operated by the United States or military aircraft of any foreign nation within the area for which the (fire organization) normally provides fire protection, the Chief of the \_\_\_\_\_ Air Force Base Fire Department or his representative may assume full command upon his arrival at the scene of the crash.
- (4) Each party waives all claims against every other party for compensation for any loss, damage, personal injury, or death occurring as a consequence of the performance of this agreement.
- (5) No party shall be reimbursed by any other party for any costs incurred pursuant to this agreement.
- (6) All equipment used by (fire organization) in carrying out this agreement will, at the time of action hereunder, be owned by it; and all personnel acting for (fire organization) under this agreement will, at the time of such action, be an employee or volunteer member of (fire organization).

### **F.3 Typical Civil Airport Department Mutual Aid Agreement.**

The following mutual aid agreement example is based on procedures used by the Seattle-Tacoma International Airport supplied through the courtesy of R. E. Smith, Fire Chief.

This agreement, made and entered into this \_\_\_\_\_ by and between  
 the \_\_\_\_\_ and  
 the \_\_\_\_\_

WITNESSETH:

WHEREAS, each of the parties hereto maintains equipment and personnel for the suppression of fires within its own jurisdiction and areas, and

WHEREAS, the parties hereto desire to augment the fire protection available in their establishments, district agencies, and municipalities in the event of large fires, conflagrations, and natural or technological disasters, and

WHEREAS, the agencies entering into this Agreement have an interest in providing mutual assistance in



emergencies for which each respective fire department has the capabilities to respond, and

THEREFORE BE IT AGREED THAT:

- (1) Whenever it is deemed advisable by the commanding officer of a fire department belonging to a party to this Agreement, or whenever the commanding officer of any such fire department is actually present at an emergency incident, such commanding officer may request assistance for the purpose of extinguishing, controlling, or aiding in the extinguishing or controlling of fires, or in the mitigation of emergency medical service incidents from the fire departments which are signatory to this Agreement. Under the terms of this Agreement, such commanding officer is authorized to make such a request and the commanding officer of the department receiving the request or authorized subordinates shall forthwith take the following action:
  - (a) Immediately determine if apparatus and personnel can be spared in response to the call;
  - (b) What apparatus and personnel might most effectively be dispatched;
  - (c) The exact mission to be assigned in accordance with the detailed plans and procedures of operation drawn in accordance with this Agreement by the managing representatives of the fire department concerned;
  - (d) Dispatch such apparatus and personnel as the responsible officer receiving the call reasonably believes should be sent, with complete instructions as to the mission, in accordance with the terms of this Agreement and pursuant to the instructions received in the request for assistance.
- (2) The tendering of assistance under the terms of this Agreement shall not be mandatory, but the party receiving the request of assistance should immediately inform the requesting agency if, for any reason, assistance cannot be rendered.
- (3) Each party to this Agreement waives all claims against the other party or parties for compensation for any loss, damage, personal injury, or death occurring in consequence of the performance of this Agreement.
- (4) Each party to this Agreement shall maintain its own insurance coverage for equipment and personnel.
- (5) All services performed under this Agreement shall be rendered without reimbursement of either party or parties.
- (6) The commanding officer of the fire department requesting assistance shall not relinquish responsibility for mitigating the emergency incident to those officers responding pursuant to the terms of this Agreement. A senior officer of a responding mutual aid department will make him/herself available to the commanding officer for consultation as a resource person, to assist in tactical or strategical decisions during the emergency. As often as is practically possible, the mutual aid departments will remain intact under the direct supervision of the highest ranking officer from their own department. Direction for the responding department's fire fighters' and subordinate officers' activities will, however, come from the commanding officer of the fire department initiating the request for assistance.
- (7) The chief fire officers and personnel of the fire departments of both parties to this Agreement are invited and encouraged, on a reciprocal basis, to frequently visit each other's activities for guided familiarization tours consistent with local security requirements and, as feasible, to jointly conduct pre-fire planning inspections and drills.
- (8) The commanding officers of the fire departments of the parties of this Agreement are authorized to meet and draft any detailed plans and procedures of operation necessary to effectively implement this

Agreement. Such plans and procedures of operations shall become effective upon ratification by the signatory parties.

- (9) This Agreement shall become effective upon the date hereof and shall remain in full force and effect until cancelled by mutual agreement of the parties hereto or by written notice by one party to the other party, giving ten (10) days notice of said cancellation.

IN WITNESS THEREOF, the parties hereto have executed this Agreement at \_\_\_\_\_, Washington, on the day and year first above written.

PORT OF SEATTLE FIRE DEPARTMENT

## Annex G Hazardous Materials

*This annex is not a part of the recommendations of this NFPA document but is included for informational purposes only.*

### **G.1 Class/Division.**

Class/division is the general category of hazard assigned to a hazardous material under the DOT regulations. The division is a subdivision of a hazard class.

Class 1 (Explosives)

Division 1.1 — Explosives with a mass explosion hazard

Division 1.2 — Explosives with a projection hazard

Division 1.3 — Explosives with predominantly a fire hazard

Division 1.4 — Explosives with no significant blast hazard

Division 1.5 — Very insensitive explosives

Division 1.6 — Extremely insensitive explosive articles

Class 2

Division 2.1 — Flammable gas

Division 2.2 — Nonflammable, non-poisonous compressed gas

Division 2.3 — Poison gas

Division 2.4 — Corrosive gas (Canadian designation)

Class 3 (Flammable liquid)

Division 3.1 — Flammable liquids, flash point <0°F

Division 3.2 — Flammable liquids, flash point 0°F and above, but <73°F

Division 3.3 — Flammable liquids, flash point 73°F and up to 141°F

Combustible Liquid

Class 4

Division 4.1 — Flammable solid  
Division 4.2 — Spontaneously combustible material  
Division 4.3 — Dangerous when wet material  
Class 5  
Division 5.1 — Oxidizer  
Division 5.2 — Organic peroxide  
Class 6  
Division 6.1 — Poisonous material  
Division 6.2 — Infectious material  
Class 7 (Radioactive material)  
Class 8 (Corrosive material)  
Class 9 (Miscellaneous hazardous material)  
ORM-D material

## Annex H Informational References

### H.1 Referenced Publications.

The following documents or portions thereof are referenced within the annexes of this guide.

**H.1.1 NFPA Publications.** National Fire Protection Association, 1 Batterymarch Park, P.O. Box 9101, Quincy, MA 02269-9101.

NFPA 407, *Standard for Aircraft Fuel Servicing*, 2001 edition.

NFPA 410, *Standard on Aircraft Maintenance*, 1999 edition.

*Fire Protection Guide on Hazardous Materials.*

### H.1.2 Other Publications.

**H.1.2.1 IATA Publication.** International Air Transport Association Headquarters, IATA Building, 2000 Peel Street, Montreal, Canada H3A 2R4.

*Restricted Articles Regulations.*

**H.1.2.2 U.S. Government Publication.** U.S. Government Printing Office, Washington, DC 20402.

Title 49, *Code of Federal Regulations*, Part 175, “Transportation.”

### H.2 Informational References.

The following documents or portions thereof are listed here as informational resources only. They are not directly referenced in this guide.

**H.2.1 ICAO Publications.** International standards and recommended practices are promulgated by the

Copyright NFPA

International Civil Aviation Organization, 999 University St., Montreal, Quebec PQ, Canada H3C 5H7.

*Aerodromes* (Annex 14), 3rd edition, July 1999.

*Airport Services Manual, Part I: "Rescue and Fire Fighting,"* 3rd edition, 1990.

*Emergency Response Guidance for Aircraft Incidents Involving Dangerous Goods*, 1st edition, March 2001-2002.

Aircraft Accident and Incident Investigation (Annex 13) 8th edition, July 1994, Reprinted 1999.

Manual of Aircraft Accident Investigation (Document 6920), 4th edition, 1970, Reprinted 1995.

*Airport Service Manual, Part 5, Removal of Disabled Aircraft*, 3rd edition, 1996.

**H.2.2 U.S. Government Publications.** Superintendent of Documents, U.S. Government Printing Office, Washington, DC 20402.

**H.2.2.1 FAR Part 139.** Part 139 is sold on a subscription basis by the Superintendent of Documents. Subscribers will receive changes to this part automatically.

**H.2.2.2 Federal Aviation Administration Publications.** Available from Department of Transportation, Distribution Unit, M-494.3, Washington, DC 20590.

*Advisory Circulars.* This listing is limited to those free advisory circulars relating to aircraft rescue and fire fighting services. For a complete listing of FAA advisory circulars, write to the address above and request a copy of the latest "Advisory Circular Checklist and Status of Other FAA Publications." This checklist is also published periodically in the Federal Register.

150/5200-12A, *Fire Department Responsibility in Protecting Evidence at the Scene of an Aircraft Accident* (4-8-85) (AAS-100). Furnishes general guidance for airport employees, airport management, and other personnel responsible for fire fighting and rescue operations, at the scene of an aircraft accident, on the proper presentation of evidence.

150/5200-15C, Announcement of Availability — International Fire Service Training Association's Manual 206, *Aircraft Fire Protection and Rescue Procedures* (second edition, 1978) (8-26-82) (AAS-100). Explains the nature of the manual and tells how it can be obtained.

150/5200-18A, *Airport Safety Self-Inspection* (12-18-85) (AAS-310). Suggests functional responsibility, procedures, a checklist, and schedule for an airport safety self-inspection.

150/5200-21A, Announcing the Availability of U.S. Air Force Technical Order (T.O. 00-105E-9) *Aircraft Emergency Rescue Information* (2-24-81) (AAS-100). Explains the nature of the Technical Order and tells how it can be obtained.

150/5210-2A, *Airport Emergency Medical Facilities and Services* (11-27-84) (AAS-300). Provides information and advice so that airports can take specific voluntary pre-incident planning actions to ensure at least minimum first aid and medical readiness appropriate to the size of the airport in terms of permanent and transient personnel.

150/5210-6C, *Aircraft Fire and Rescue Facilities and Extinguishing Agents* (1-28-85) (AAS-100). Outlines scales of protection considered as the recommended level compared with the minimum level in Federal Aviation Regulation Part 139.49 and tells how these levels were established from test and experience data.

150/5210-13, *Water Rescue Plans, Facilities, and Equipment* (5-4-72) (AAS-300). Suggests planning procedures, facilities, and equipment to effectively perform rescue operations when an aircraft lands in a body  
Copyright NFPA

of water, swamp, or tidal area where normal aircraft fire fighting and rescue service vehicles are unable to reach the accident scene.

150/5210-14, *Airport Fire and Rescue Personnel Protective Clothing* (3-12-86) (AAS-100). Developed to assist airport management in the development of local procurement specifications for an acceptable, cost-effective proximity suit for use in aircraft rescue and fire fighting operations.

150/5210-15, *Airport Rescue and Fire Fighting Station Building Design* (7-30-87) (AAS-100). Provides standards and guidance for planning, designing, and constructing an airport rescue and fire fighting station.

150/5210-58, *Painting, Marking, and Lighting of Vehicles Used on an Airport* (7-11-86) (AAA-120). Provides guidance, specifications, and standards, in the interest of airport personnel safety and operational efficiency, for painting, marking, and lighting of vehicles operating in the airport air operations areas.

150/5210-78, *Aircraft Fire and Rescue Communications* (4-30-84) (AAS-120). Provides guidance and information for planning and implementing an airport communications system for airport fire and rescue service.

150/5220-4A, *Water Supply Systems for Aircraft Fire and Rescue Protection* (12-11-85) (AAS-120). Provides guidance for the water source selection and standards for a water distribution system designed to support aircraft rescue and fire fighting (ARFF) service operations on airports.

150/5220-9, *Aircraft Arresting Systems for Joint Civil/Military Airports* (4-6-70) (AAS-300). Updates existing policy and describes and illustrates the various types of military aircraft emergency arresting systems that are now installed at various joint civil/military airports. It also informs users of criteria concerning installations of such systems at joint civil/military airports.

150/5220-10, *Guide Specification for Water/Foam Type Aircraft Fire and Rescue Trucks* (5-26-72) (Consolidated reprint incorporates changes 1 and 2) (AAS-100). Assists airport management in the development of local procurement specifications.

150/5220-14A, *Airport Fire and Rescue Vehicle Specification Guide* (2-25-85) (AAS-100). Assists airport management in the development of local procurement specifications.

150/5230-4, *Aircraft Fuel Storage, Handling, and Dispensing on Airports* (8-27-82) (AAS-300). Provides information on aviation fuel deliveries to airport storage and the handling, cleaning, and dispensing of fuel into aircraft.

150/5230-4, Chg. 1 (2-20-86).

150/5230-4, Chg. 2 (7-1-87).

150/5280-1, *Airport Operations Manual* (6-16-72) (AAS-310). Sets forth guidelines to assist airport operators in developing an Airport Operations Manual in compliance with the requirements of FAR Part 139.

150/5280-1, Chg. 1 (3-24-81).

150/5280-3, *Fire Fighting Exemptions Under the 1976 Amendment to the Federal Aviation Act* (2-4-77) (AAS-100). Outlines the type of information that can be used as justification in supporting petitions for exemption from a portion or all of the fire fighting and rescue requirements of Part 139.

150/5325-5C, *Aircraft Data* (6-29-87) (AAS-100). Presents a listing of principal aircraft weights and dimensions which affect airport facility design. It is to be used for guidance in airport development. Data presented are for common civil aircraft and those military aircraft which frequently utilize civil facilities.

150/5340-1E, *Marking of Paved Areas on Airports* (11-4-80) (AAS-200). Describes standards for marking paved runways, taxiways, closed and/or hazardous areas on airports.

150/5340-18B, *Standards for Airport Sign Systems* (8-21-84) (AAS-200). Contains the Federal Aviation Administration standards for use on airports.

150/5355-1A, *International Signs to Facilitate Passengers Using Airports* (11-3-71) (AAS-100). Informs airport authorities of the desirability to provide international signs and diagrammatic maps within terminal buildings and of the need of clearly marked road signs for airports.

150/5355-2, *Fallout Shelters in Terminal Buildings* (4-1-69) (AAS-100). Furnishes guidance for the planning and design of fallout shelters in airport terminal buildings.

150/5360-12, *Airport Signing and Graphics* (12-23-85) (AAS-110). Provides guidance on airport related signs and graphics.

150/5370-2C, *Operational Safety on Airports During Construction* (5-31-84) (AAS-300). Concerning operational safety on airports with special emphasis on safety during periods of construction activity, to assist airport operators in complying with Part 139.

150/5380-5A, *Debris Hazards at Civil Airports* (2-25-81) (AAS-100). Discusses problems of debris at airports, gives information on foreign objects, and tells how to eliminate such objects from operational areas.

### **H.2.2.3 United States Military Publications.**

Air Force: Technical Manual 00-105E-9, *Aircraft Emergency (Fire Protection Information)*, available from HQ WR-ALC (MMEOTD), Robbins AFB, GA 31093.

Navy and Marine: NAVAIR 00-80R-14, *Aircraft Fire Fighting and Rescue Manual for US Naval and Marine Air Stations and Facilities*, available from Naval Air Technical Services Facility, 700 Robins Avenue, Philadelphia, PA 19111.

Army: *Technical Manual 5-315*, available from Superintendent of Public Documents, Public Documents Department, U.S. Government Printing Office, Washington, DC 20402.

### **H.2.2.4 Other Publication.**

*Advanced Techniques in Impact Protection and Emergency Egress from Air Transport Aircraft*, R.G. Snyder Report, HEARD-AG 221, National Transportation Safety Board Accident Reports.

## **H.3 References for Extracts.**

The following documents are listed here to provide reference information, including title and edition, for extracts given throughout this guide as indicated by a reference in brackets [ ] following a section or paragraph.

NFPA 10, *Standard for Portable Fire Extinguishers*, 2002 edition.

NFPA 17, *Standard for Dry Chemical Extinguishing Systems*, 2002 edition.

NFPA 302, *Fire Protection Standard for Pleasure and Commercial Motor Craft*, 1998 edition.

NFPA 403, *Standard for Aircraft Rescue and Fire-Fighting Services at Airports*, 1998 edition.

NFPA 408, *Standard for Aircraft Hand Portable Fire Extinguishers*, 1999 edition.

NFPA 424, *Guide for Airport/Community Emergency Planning*, 2002 edition.

NFPA 472, *Standard for Professional Competence of Responders to Hazardous Materials Incidents*, 2002 edition.

NFPA 473, *Standard for Competencies for EMS Personnel Responding to Hazardous Materials Incidents*, 2002 edition.

NFPA 600, *Standard on Industrial Fire Brigades*, 2000 edition.

NFPA 921, *Guide for Fire and Explosion Investigations*, 2001 edition.

NFPA 1051, *Standard for Wildland Fire Fighter Professional Qualifications*, 2002 edition.

NFPA 1670, *Standard on Operations and Training for Technical Rescue Incidents*, 1999 edition.

[Click here to view and/or print an Adobe® Acrobat® version of the index for this document](#)