

NFPA Aluminum & Steel Cylinders

NFPA Series A Aluminum & J Steel Cylinders

1-1/2 to 12 inch bore size

Impact dampening seals

Adjustable captive cushion needle

Ecology cylinders meet OSHA noise standards

Constructed of the finest materials

Technical data

Medium:

Filtered compressed air to 250 PSI

Petroleum based hydraulic fluid to 400 PSI*

Operating temperature:

Series A & J -20°F to 200°F

with Viton Seals -20°F to 400°F

Operating Pressure:

250 PSIG Air, 400 PSIG Hydraulic* non-shock.

NOTE: EA and EJ max pressure rating: 150 psi.

Bore Sizes: 1-1/2", 2", 2-1/2", 3-1/4", 4", 5", 6", 7", 8", 10", 12"*

Lubrication:

None required

Norgren Air Cylinders are rated for "no lube added" service. All internal components are lubricated at time of assembly with a Teflon® based grease.

Materials

Head and End Caps:

(A and EA Series)

black anodized aluminum alloy

(J and EJ Series)

precision machined steel*

Tube:

A & EA Series 1-1/2" to 12"

J & EJ Series 1-1/2" to 2-1/2"

Aluminum alloy, clear anodized O.D., hard coat anodized I.D.

J & EJ Series 3-1/4" to 12" has steel tube, with hard chrome plated I.D.

Piston:

A & EA series: machined high-strength aluminum alloy.

J & EJ series: steel

Piston rod: hard chrome plated steel

Rod Bearing: oil impregnated sintered iron

Seals: nitrile rod seal, urethane rod wiper, nitrile piston seals, nitrile tube end seals

Tie Rods: high-tensile strength steel

* J and EJ series only



1 Ultra Cushion® Seals: Advanced design features a unique, one-piece, compound seal of nitrile* captured within a precision machined groove. Linear and radial "float" of the cushion seals eliminates misalignment. Ultra Cushions provide exceptionally fast "out of cushion" stroke reversal. (Head and Cap Cushions are optional.)

*Nitrile seals on the 5/8" & 1" rod diameter. For rod sizes 1-3/4" and larger, urethane seals are standard.

2 O-Ring Tube Seal: Nitrile is standard. (Viton is optional.)

3 Adjustable Captive Cushion Needle: A one-piece, precision threaded brass cushion adjustment screw with a threaded steel capture ring. It provides safe and precise cushion adjustment.

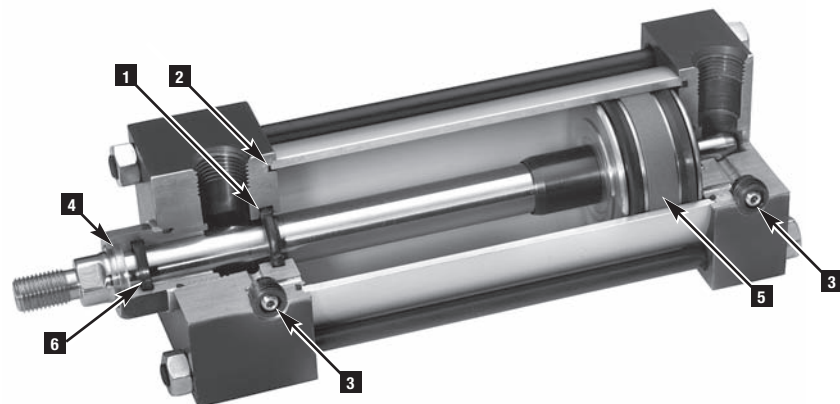

4 Wiper Seal: Lip-type urethane wiper seal keeps contaminants from getting into cylinder by aggressively wiping foreign materials from the piston rod, enhancing the rod seal life.

6 Rod Seal: Nitrile lip type seal is pressure energized and wear compensating for durability and long life.

5 Wear Ring: Reinforced Teflon® compounded with polyphenylene sulfide provides supreme wear and excellent bearing support.

Series A Cylinders are constructed with the finest materials for each component!

- 1** Piston Rod: Hard chrome plated high-tensile steel, ground and polished.
- 2** Rod Bearing: External removable threaded steel bearing housing (black oxide finish), with an oil-impregnated sintered iron rod bearing.
- 3** Rod Seal: Nitrile lip-type seal is pressure energized and wear compensating for durability and long life.
- 4** Head/Cap: Precision machined from alloy aluminum, then anodized for corrosion resistance (black finish).

- 5** Ultra Cushion® Seals: Advanced design features a unique, one-piece, compound seal of nitrile* captured within a precision machined groove. Linear and radial “float” of the cushion seals eliminates misalignment. Ultra Cushions provide exceptionally fast “out of cushion” stroke reversal. (Head and Cap Cushions are optional.)
*Nitrile seals on the 5/8" & 1" rod diameter.
For rod sizes 1-3/8" and larger, urethane seals are standard.
- 6** O-Ring Tube Seal: Buna is standard. (Viton is optional.)

- 7** Tie Rods: High-strength steel maintains uniform compression on tube end seals.
- 8** Piston: Machined solid aluminum alloy, lightweight for low inertia, yet strong. Threaded piston is installed with high strength threadlocker adhesive then staked to the piston rod.
- 9** Adjustable Captive Cushion Needle: A one-piece, precision threaded brass cushion adjustment screw with a threaded steel capture ring. It provides safe and precise cushion adjustment.

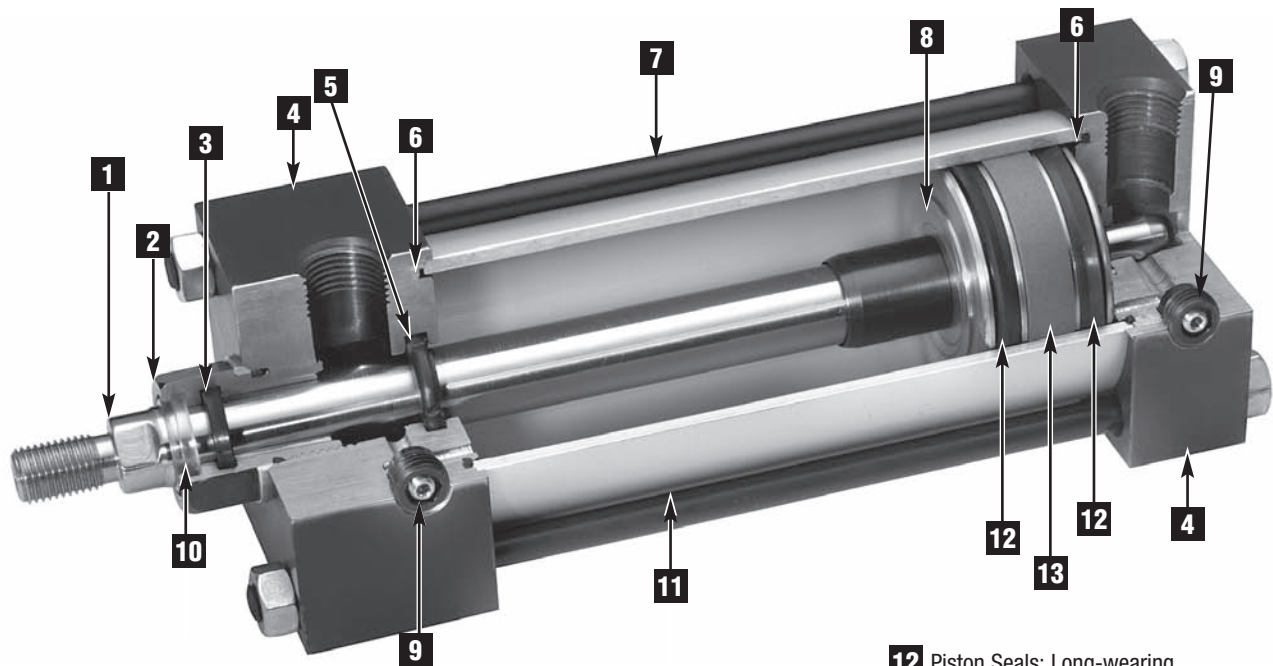

- 10** Wiper Seal: Lip-type urethane wiper seal keeps contaminants from getting into cylinder by aggressively wiping foreign materials from the piston rod, enhancing the rod seal life.

- 11** Cylinder Tube: High-strength aluminum alloy ideally suited for air service. The tube is clear anodized on the O.D. and hard anodic coated on the I.D., resulting in a smooth, corrosion and score resistant surface finish.

- 12** Piston Seals: Long-wearing nitrile seals.

- 13** Wear Ring: Reinforced Teflon® compounded with polyphenylene sulfide provides supreme wear and excellent bearing support.

Application Information

Series A NFPA interchangeable aluminum air cylinders are offered with a variety of accessories, standard and optional equipment to meet your application needs.

The addition of a Teflon® wear ring to the outer perimeter of the piston provides lubrication to the cylinder for an extended period of time over cylinders without a wear ring.

Standard non-cushioned Series A cylinders are recommended for applications that require full bottoming of the piston and where the noise emitted by the metal-to-metal impact between the piston and cylinder end caps is tolerable. We recommend that optional non-adjustable cushions be added for piston speeds (moving light tools) ranging from 15 to 30 in/sec. For speeds exceeding 30 in/sec, the cylinders should be equipped with adjustable air cushions.

NFPA Aluminum & Steel Cylinders

Series EA Ecology Cylinders are constructed with the finest materials for each component!

1 Ultra Cushion® Seals: Advanced design features a unique, one-piece, compound seal of nitrile® captured within a precision machined groove. Linear and radial “float” of the cushion seals eliminates misalignment. Ultra Cushions provide exceptionally fast “out of cushion” stroke reversal. (Head and Cap Cushions are optional.)

*Nitrile seals on the 5/8" & 1" rod diameter.

For rod sizes 1-3/8" and larger, urethane seals are standard.

2 Impact Dampening Piston Seals: Our impact dampening piston seals, in conjunction with our advanced cushion design, decelerate and reduce end-of-stroke noise.

3 Piston: Machined solid aluminum alloy, lightweight for low inertia, yet strong. Threaded piston is installed with high strength threadlocker adhesive then staked to the piston rod.

4 O-Ring Tube Seal: Buna is standard. (Viton is optional.)

5 Adjustable Captive Cushion Needle (not shown): Fine thread allows for safe and precision adjustment of cushion.

6 Wiper Seal: Lip-type urethane wiper seal keeps contaminants from getting into cylinder by aggressively wiping foreign materials from the piston rod, enhancing the rod seal life.

7 Piston Rod: Hard chrome plated high-tensile steel, ground and polished.

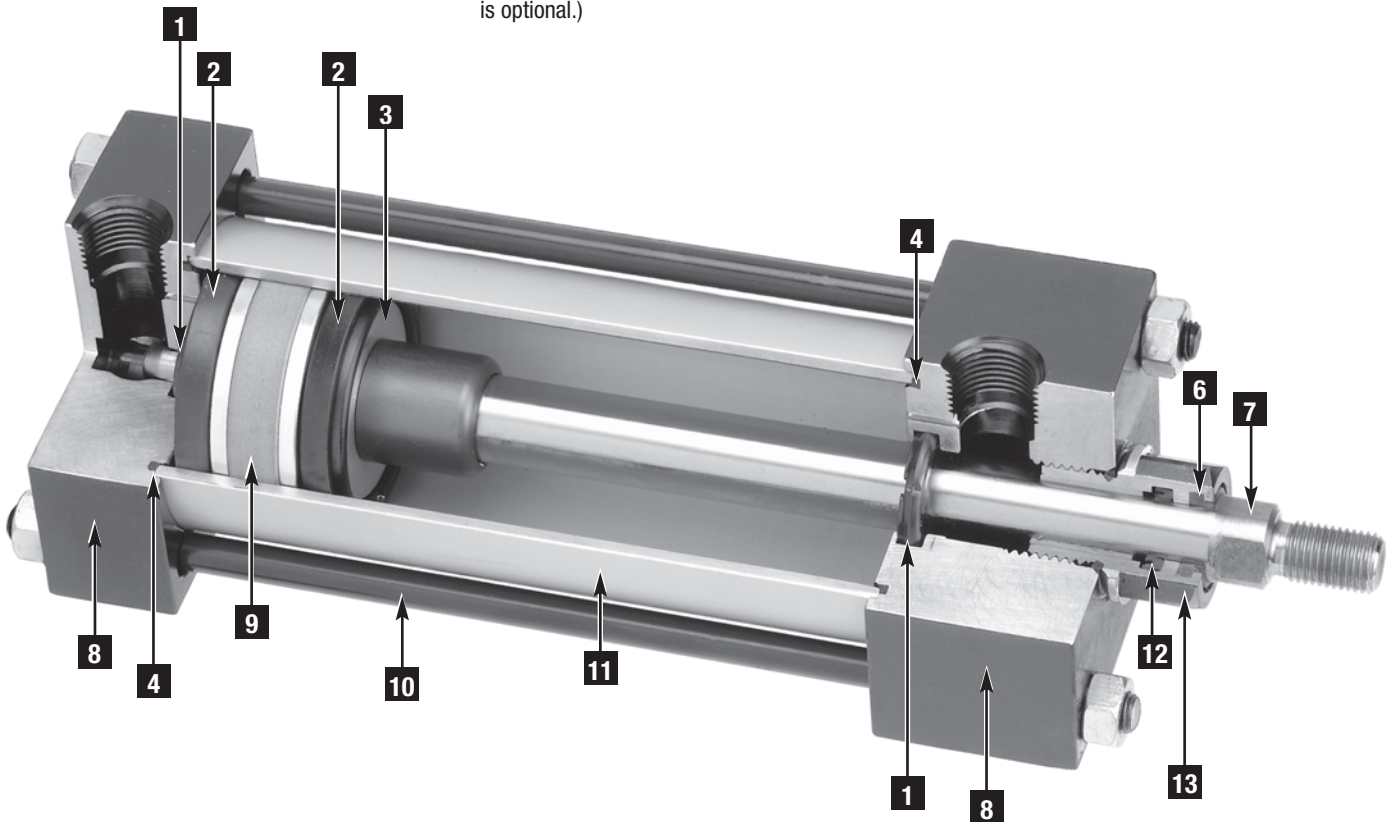

8 Head/Cap: Precision machined from alloy aluminum, then anodized for corrosion resistance (black finish).

9 Wear Ring: Reinforced Teflon® compounded with polyphenylene sulfide provides supreme wear and excellent bearing support.

10 Tie Rods: High-strength steel maintains uniform compression on tube end seals.

11 Cylinder Tube: High-strength aluminum alloy ideally suited for air service. The tube is clear anodized on the O.D. and hard anodic coated on the I.D., resulting in a smooth, corrosion and score resistant surface finish.

12 Rod Seal: Nitrile lip-type seal is pressure energized and wear compensating for durability and long life.

13 Rod Bearing: External removable steel bearing housing (black oxide finish), with an oil-impregnated sintered iron rod bearing.

NFPA Aluminum & Steel Cylinders

Series J Cylinders are constructed with the finest materials for each component!

- 1** Piston Rod: Hard chrome plated high-tensile steel, ground and polished.
- 2** Rod Bearing: External removable threaded steel bearing housing (black oxide finish), with an oil-impregnated sintered iron rod bearing.
- 3** Rod Seal: Nitrile lip-type seal is pressure energized and wear compensating for durability and long life.
- 4** Head/Cap: Precision machined from steel, then black oxide finished 1-1/2" to 2-1/2" bores. Painted black finish on 3-1/4" to 12" bores.
- 5** Ultra Cushion® Seals: Advanced design features a unique, one-piece, compound seal of nitrile* captured within a precision machined groove. Linear and radial "float" of the cushion seals eliminates misalignment. Ultra Cushions provide exceptionally fast "out of cushion" stroke reversal. (Head and Cap Cushions are optional.) *Nitrile seals on the 5/8" & 1" rod diameter. For rod sizes 1-3/8" and larger, urethane seals are standard.
- 6** O-Ring Tube Seal: Buna is standard. (Viton is optional.)
- 7** Rods: High-strength steel maintains uniform compression on tube end seals.
- 8** Piston: Machined solid steel, for high strength. Threaded piston is installed with high strength threadlocker adhesive then staked to the piston rod.
- 9** Adjustable Captive Cushion Needle: A one-piece, precision threaded brass cushion adjustment screw with a threaded steel capture ring. It provides safe and precise cushion adjustment.

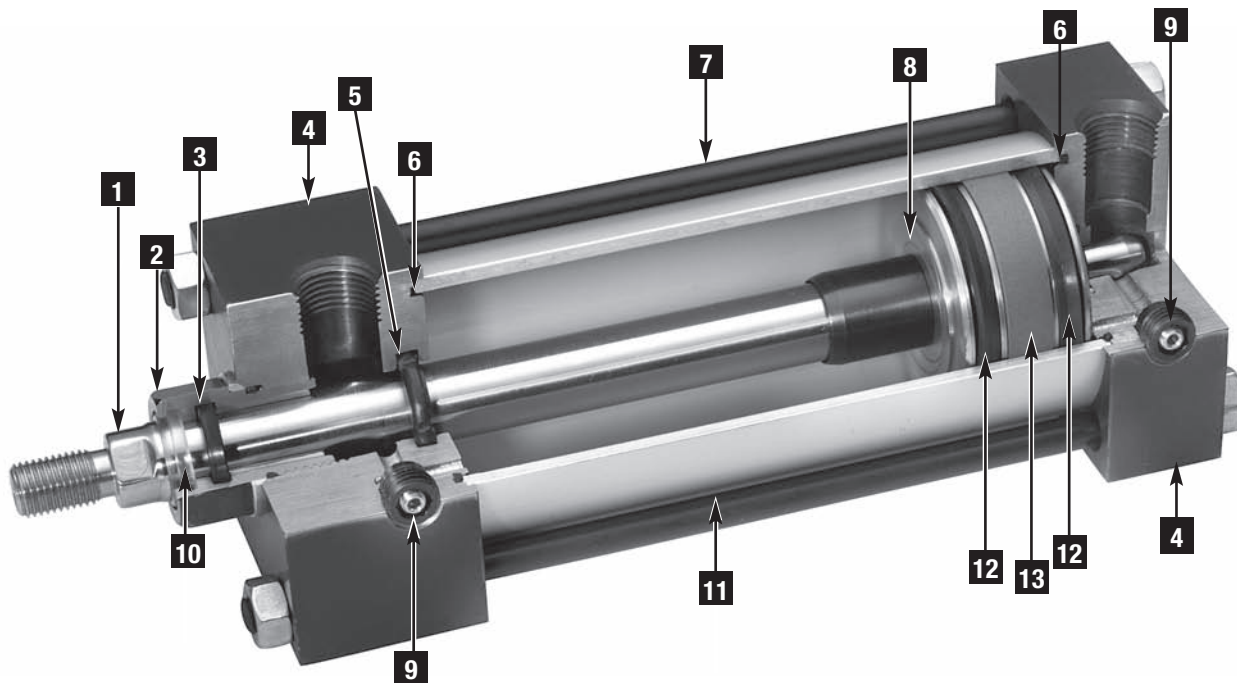

- 10** Wiper Seal: Lip-type urethane wiper seal keeps contaminants from getting into cylinder by aggressively wiping foreign materials from the piston rod, enhancing the rod seal life.
- 11** Cylinder Tube: High-strength aluminum alloy 1-1/2", 2", 2-1/2" bore anodized on the O.D. and hard coat I.D. Steel cylinder tube hard chrome plated I.D. 3-1/4" to 12" bore.
- 12** Piston Seals: Long-wearing nitrile seals.
- 13** Wear Ring: Reinforced Teflon® compounded with polyphenylene sulfide provides supreme wear and excellent bearing support.

Application Information

Series J NFPA interchangeable steel air cylinders are offered with a variety of accessories, standard and optional equipment to meet your application needs.

The addition of a Teflon® wear ring to the outer perimeter of the piston provides lubrication to the cylinder for an extended period of time over cylinders without a wear ring.

Standard non-cushioned Series J cylinders are recommended for applications that require full bottoming of the piston and where the noise emitted by the metal-to-metal impact between the piston and cylinder end caps is tolerable. We recommend that optional non-adjustable cushions be added for piston speeds (moving light tools) ranging from 15 to 30 in/sec. For speeds exceeding 30 in/sec, the cylinders should be equipped with adjustable air cushions.

NFPA Aluminum & Steel Cylinders

Series EJ Ecology Cylinders are constructed with the finest materials for each component!

1 Ultra Cushion® Seals: Advanced design features a unique, one-piece, compound seal of nitrile* captured within a precision machined groove. Linear and radial “float” of the cushion seals eliminates misalignment. Ultra Cushions provide exceptionally fast “out of cushion” stroke reversal. (Head and Cap Cushions are optional.)

*Nitrile seals on the 5/8" & 1" rod diameter.

For rod sizes 1-3/8" and larger, urethane seals are standard.

2 Impact Dampening Piston Seals: Our impact dampening piston seals, in conjunction with our advanced cushion design, decelerate and reduce end-of-stroke noise.

3 Piston: Machined solid steel, for high strength. Threaded piston is installed with high strength threadlocker adhesive then staked to the piston rod.

4 O-Ring Tube Seal: Buna is standard. (Viton is optional.)

5 Adjustable Captive Cushion Needle (not shown): Fine thread allows for safe and precision adjustment of cushion.\

6 Wiper Seal: Lip-type urethane wiper seal keeps contaminants from getting into cylinder by aggressively wiping foreign materials from the piston rod, enhancing the rod seal life.

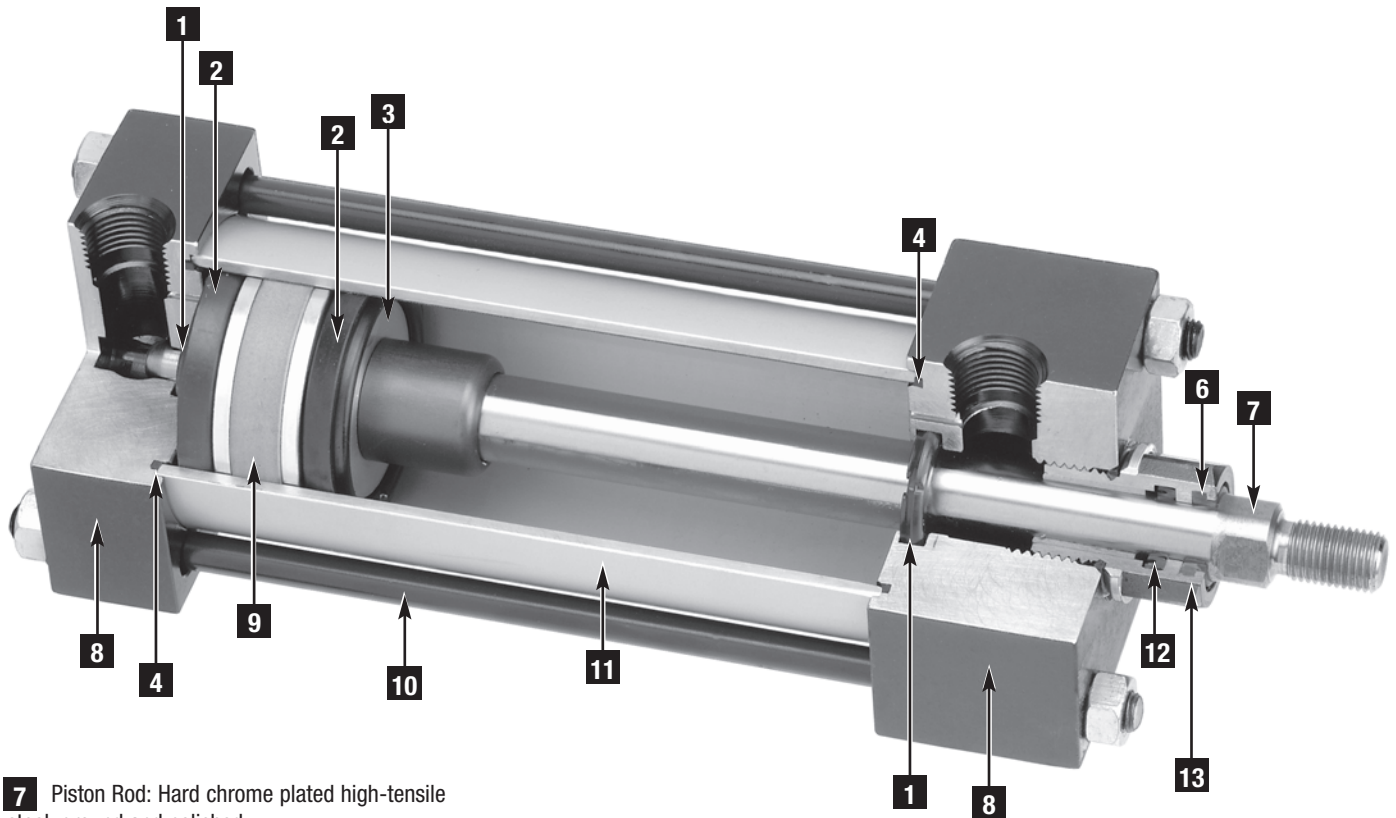

7 Piston Rod: Hard chrome plated high-tensile steel, ground and polished.

8 Head/Cap: Precision machined from steel, then black oxide finished 1-1/2" to 2-1/2" bores. Painted black finish 3-1/4" to 12" bores.

9 Wear Ring: Reinforced Teflon® compounded with polyphenylene sulfide provides supreme wear and excellent bearing support.

10 Tie Rods: High-strength steel maintains uniform compression on tube end seals.

11 Cylinder Tube: High-strength aluminum alloy 1-1/2", 2", 2-1/2" bore anodized on the O.D. and hard coat I.D. Steel cylinder tube hard chrome plated I.D. 3-1/4" to 12" bore.

12 Rod Seal: Nitrile lip-type seal is pressure energized and wear compensating for durability and long life.

13 Rod Bearing: External removable steel bearing housing (black oxide finish), with an oil-impregnated sintered iron rod bearing.

Norgren NFPA Ecology Cylinders offer these advantages:

1 Norgren cylinders are pre-lubricated for non-lube operation.

The piston rod is self-lubricated by the oil-impregnated rod bearing during operation. Lubrication between piston and cylinder barrel is derived from the polishing qualities of the reinforced Teflon® wear ring.

The low friction surfaces extend the life of the seals beyond normal expectations.

Series EA and EJ cylinders are NFPA interchangeable and are available in many different mounting styles.

2 Operates Quietly to Meet OSHA Specifications.

Series EA and EJ cylinders provide substantial reductions in impact noise, which reduces overall machine noise and helps meet government regulations.

The summary of sound decibels chart illustrates the operating sound levels.

The impact dampening qualities of the Piston Seals are guaranteed for ONE FULL YEAR!

Summary of Sound Levels in Decibels

PSI Air Sound Pressure Level+		Cylinder Model							
		J133B3 5" x 6"	EJ155B3 5" x 6"	J1133A3 2" x 6"	EJ1155A3 2" x 6"	A133B3 5" x 6"	EA155B3 5" x 6"	A1133A3 2" x 6"	EA1155A3 2" x 6"
95 PSI+	End++	108	73	110	74	108	73	110	74
	Side++	112	84	110	81	112	84	110	81
50 PSI+	End++	108	73	113	74	108	73	113	74
	Side++	113	85	110	81	113	85	110	81

+ Peak sound pressure is given in decibels (dB) re: 2 x 10⁻⁵ N/m².

++End position of mike was 3' on centerline from end of cylinder; side position of mike was 3' perpendicular to centerline abeam of end of cylinder.

Note: At 5 feet, cylinder sound levels would be less by 9 dB from side figure and 13 dB from end figure. The total noise emitted will depend on the structure to which the cylinder is attached. If it is mounted on a thin flat plate of considerable area, the noise will be increased by a sounding board effect.

3 Energy Absorption Capacity of the Impact Dampening Seals

Series EA and EJ cylinders have a impact dampening piston seal that accomplishes 80% of the actual load stopping. The air cushion accounts for only 20%. (A conventional air cushioning cylinder depends 100% on the compressibility of air to do the stopping.) The Ecology seal absorbs high impact loads allowing the effect of the air cushion to be reduced by using a larger air cushion bleed orifice. As a result the piston can move at a faster speed for a longer period of time before the Ecology seal does the final stopping.

Energy Absorption Capacity of the Impact Dampening Seals

*Usable Pounds Stoppable at the Following Piston Speeds

This chart features the energy absorption capacity of the impact dampening piston seals with a **Non-Adjustable** cushions. For higher loads and velocities please refer to the Decel- Air Cushion.

In/Sec	Cylinder Bore										
	1 1/2	2	2 1/2	3 1/4	4	5	6	7	8	10	12
6	155.6	275.5	499.8	969.3	1505.4	2603.2	4159.8	5794.2	8067.6	12,242	20,139
12	38.4	68.1	123.4	239.7	372.6	644.8	1030.2	1435.8	2000.4	3026	4971
18	16.7	29.7	53.7	104.6	162.8	282.1	450.6	628.7	876.8	1319.3	2162.1
24	9.2	16.3	29.4	57.3	89.4	155.2	247.8	346.2	483.6	722	1179
30	5.6	10.0	18.1	35.4	55.4	96.4	153.9	215.4	301.6	445.5	724
36	3.7	6.7	11.9	23.5	37.0	64.5	102.9	144.4	202.7	295.3	476.8
42	2.6	4.6	8.2	16.3	25.8	45.3	72.2	101.6	143.1	204.8	327.7
48	1.8	3.2	5.8	11.7	18.6	32.8	52.2	73.8	104.4	146	231
54	1.3	2.4	4.2	8.5	13.6	24.2	38.5	54.7	77.9	105.7	164.7
60	1.0	1.8	3.0	6.2	10.1	18.1	28.7	41.1	58.9	76.9	117.2

*The weight of the cylinder piston has been deducted from the figures shown above.

Note: The use of Viton® Seals limits the absorption of the impact dampening seals by 50%.

Energy absorption capacity of impact dampening piston seals w/ adjustable cushion.

In/Sec	Cylinder Bore										
	1 1/2	2	2 1/2	3 1/4	4	5	6	7	8	10	12
6	279	495	899	1,744	2,709	4,685	7,486	10,429	4,520	22,035	36,250
12	68	122	221	430	699	1,159	1,854	2,583	3,800	5,446	8,947
18	30	53	95	187	291	507	810	1,130	1,576	2,374	3,891
24	16	29	52	102	160	279	444	622	869	1,299	1,414
30	10	18	32	63	99	172	275	387	541	801	1,303
36	6.7	12	21.6	42	66	116	183	259	363	531	856
42	4.7	8.3	14.7	29	46	81	129	181	257	367	588
48	3.4	5.7	10.4	21	33	59	93	131	187	262	415
54	2.3	4.3	7.6	15.3	24	43	68	97	138	189	295
60	1.8	3.2	5.4	11	18	33	52	74	106	138	211

Effect of Impact Dampening Seals on Total Stroke of Cylinders

PSI	Cylinder Bore										
	1 1/2	2	2 1/2	3 1/4	4	5	6	7	8	10	12
0	.14	.15	.17	.19	.22	.25	.28	.32	.32	.36	.40
20	.10	.10	.12	.14	.16	.18	.20	.22	.22	.24	.26
40	.07	.07	.08	.09	.10	.12	.13	.14	.14	.15	.16
60	.04	.04	.05	.05	.06	.07	.07	.08	.08	.09	.10
80	.02	.02	.02	.02	.03	.03	.03	.04	.04	.04	.04
100	0	0	0	0	0	0	0	0	0	0	0

Note: These figures are for new cylinders. The impact dampening seals will take some compression set during operation of the cylinder and the stroke loss will decrease. Also, the pressure at zero stroke loss will decrease to about 80 psi. At pressures above those of zero stroke loss, a slight clicking sound may be produced during impact.

To determine the stroke loss for either the head or cap end, divide the value shown by 2.

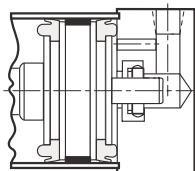

Piston and rod assembly for 1-1/2" thru 5" bore cylinders with 1/2" to 2" stroke

NFPA Aluminum & Steel Cylinders

Cushion Function

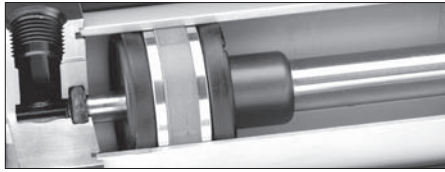

As the cushion spear enters the cushion cavity, the exhaust port becomes sealed off creating an air brake. This provides the initial deceleration in piston speed. The oversized air cushion bleed orifice permits the cushion pressure to exhaust with minimal restriction. This allows the piston to move quickly and smoothly through the cushion length.

Operating Temperatures:

Series A & J -20°F to 200°F
 (-29°C to 107°C)
 with Viton Seals -20°F to 400°F
 (-29°C to 204°C)

Operating Pressure:

250 PSIG Air (17.2 Bar)
 400 PSIG Hydraulic (27.6 Bar)
 Bore Sizes: 1-1/2", 2", 2-1/2", 3-1/4",
 4", 5", 6", 7", 8", 10", 12"

Supply:

Filtered compressed air to 250 PSI Petroleum based hydraulic fluid to 400 PSI

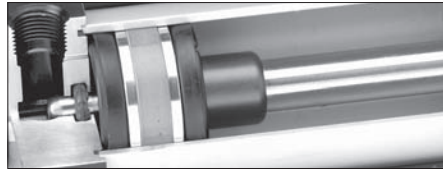

As the piston continues its travel to the point of impact with the end caps, the compressive qualities of the EJ seal provide the final decelerating force. This action compresses the EJ seal and absorbs the remaining kinetic shock vibration and noise created by the impact.

Lubrication:

None required
 Norgren Air Cylinders are rated for "no lube added" service. All internal components are lubricated at time of assembly with a Teflon® based grease.

Materials:

Head and End Caps: precision machined steel
 Tube: 6063-T832 aluminum, clear anodized O.D., hard coat anodized I.D.
 Rod: hard chrome plated steel
 Piston: machined high-strength aluminum alloy
 Rod Bearing: oil impregnated sintered iron
 Seals: nitrile rod seal, urethane rod wiper, nitrile piston seals, nitrile tube end seals
 Tie Rods: high-tensile strength steel

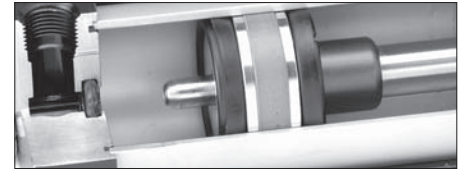

On the reverse stroke the EJ seal releases its compressive energy to propel the piston away from the end caps, producing an immediate breakaway.

Side Loading:

Cylinders are specifically designed to push and pull. Side loading (misalignment) of the piston rod should be avoided to ensure maximum operating performance and life.

Care should be taken during installation to properly align the load to be moved with the center line of the cylinder.

The use of a rod alignment coupler is strongly recommended whenever possible.

Air Cylinder Selection:

The proper application and selection of an air cylinder requires full consideration of the following: the fluid medium, operating pressures, mounting style, length of stroke, type of rod connection to the load, thrust or mounting tension on the rod, mounting attitude, speed of the stroke and how the load motion will be stopped.

The data that follows provides the necessary information in the evaluation of

an average application and will help you in selecting the proper cylinder model and size for your particular application.

Note: 1-1/2", 2", 2-1/2", 3-1/4", 4" and 5" bore cylinders with 1/2" to 2" strokes will be furnished with a short head cushion sleeve and short cap cushion spear.

Only available on 5/8" and 1" rods.

The above specification applies to Series A and J cylinders with optional non-adjustable or adjustable cushions.

Series A & J Fixed Cushions

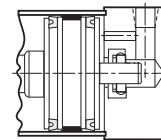

Piston and rod assembly for 1-1/2" thru 5" bore cylinders with 1/2" to 2" stroke.

Series EA & EJ Fixed Cushions

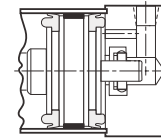

Piston and rod assembly for 1-1/2" thru 5" bore cylinders with 1/2" to 2" stroke

Ultra Cushion®

A Major Design and Performance Breakthrough in Air Cylinder Cushioning Systems!

Norgren's advanced cushion design features a unique, one-piece, nitrile compound seal that is captured within a precision machined groove. This allows both linear and radial "float" of the cushion seal which virtually eliminates problems associated with misalignment. Integral flow paths molded in the periphery of the seal provide exceptionally fast "out of cushion" stroke reversal without the use of ball checks.

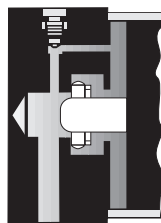

Figure 1

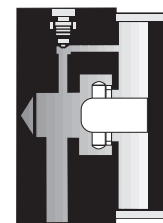

Figure 2 shows spear exiting cushion seal.



NFPA Aluminum & Steel Cylinders

Tests by the Milwaukee School of Engineering confirm Ecology Cylinder Cushions are more efficient, faster acting and bounce less!

NORGREN ECOLOGY CYLINDERS with Non-Adjustable Cushions

2" Bore Rod End Cushion Test
 Average deceleration force = 15 G's
 Time consumed during cushioning = 0.030 sec.
 Number of bounces: 1 Pneumatic – 1 Metallic

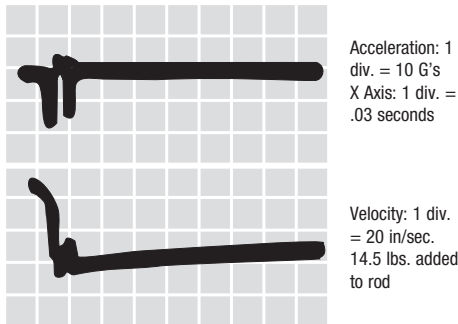

NORGREN ECOLOGY CYLINDERS with Adjustable Cushions

2" Bore Rod End Cushion Test
 Average deceleration force = 20 G's
 Time consumed during cushioning = 0.015 sec.
 Number of bounces: 1/2 Pneumatic – 0 Metallic

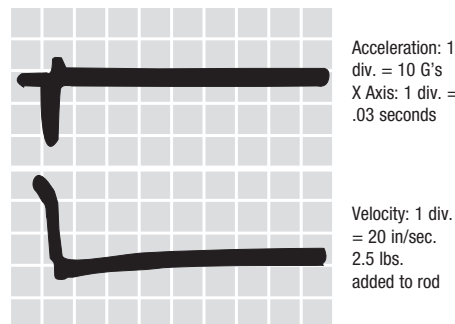

COMPETITIVE CYLINDERS with Adjustable Cushions

2" Bore Rod End Cushion Test
 Average deceleration force = 78 G's
 Time consumed during cushioning = 0.120 sec.
 Number of bounces: 2 Pneumatic – 4 Metallic

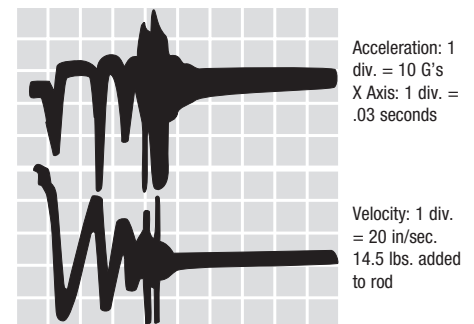

2" Bore Cap End Cushion Test

Average deceleration force = 17.5 G's
 Time consumed during cushioning = 0.025 sec.
 Number of bounces: 1 Pneumatic – 1 Metallic

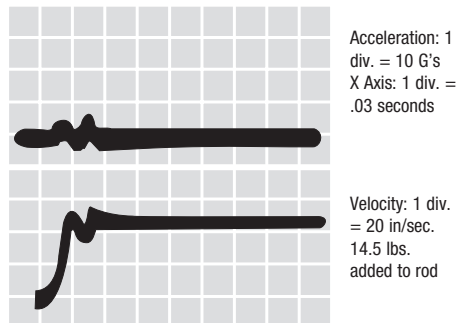

2" Bore Cap End Cushion Test

Average deceleration force = 10 G's
 Time consumed during cushioning = 0.020 sec.
 Number of bounces: 1/2 Pneumatic – 0 Metallic

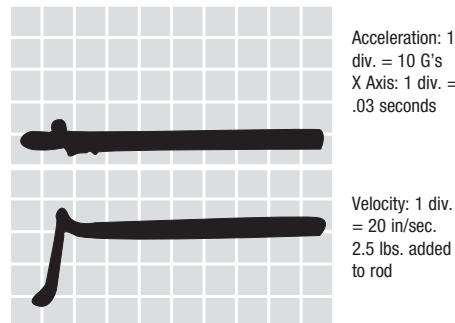

2" Bore Cap End Cushion Test

Average deceleration force = 60 G's
 Time consumed during cushioning = 0.120 sec.
 Number of bounces: 3 Pneumatic – 4 Metallic

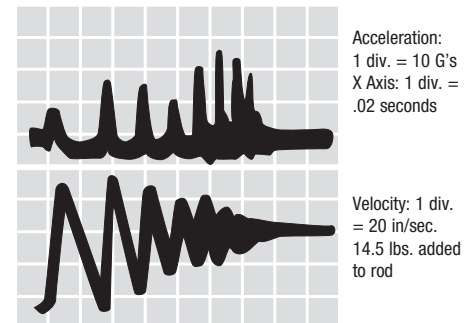

2" Bore Cylinder Tests Results

Figures shown are average and not the result of each individual test. Piston velocity was regulated at 45 in/sec.

Cylinders with Cushions	Weight attached to Piston Rod (lbs)	Cushion Efficiency (G's* Created)	Cushioning Time (Ms)	Bounce Cycles During Cushioning
Norgren Ecology Adjustable	8.5	14.50	25.00	1.00
Norgren Ecology Non-Adjustable	8.5	17.50	26.25	1.75
Competitor A Adjustable	8.5	48.00	107.50	7.25
Competitor B Adjustable	8.5	32.75	102.50	6.50
Competitor C Adjustable	8.5	50.50	81.25	9.25

*Measured in G's of deceleration force created. All cylinders tested were NFPA types, front flange mounting, 6" stroke with standard diameter piston rods.

4" Bore Cylinder Tests Results

Figures shown are average and not the result of each individual test. Piston velocity was regulated at 25 in/sec.

Cylinders with Cushions	Weight attached to Piston Rod (lbs)	Cushion Efficiency (G's* Created)	Cushioning Time (Ms)	Bounce Cycles During Cushioning
Norgren Ecology Adjustable	54	5.25	40.00	3.25
Norgren Ecology Non-Adjustable	54	12.00	28.75	2.75
Competitor A Adjustable	54	11.50	92.50	6.75
Competitor B Adjustable	54	8.00	77.50	5.25
Competitor C Adjustable	54	6.50	67.50	6.25

*Measured in G's of deceleration force created. All cylinders tested were NFPA types, front flange mounting, 6" stroke with standard diameter piston rods.

NFPA Aluminum & Steel Cylinders

Decel-Air Cushioned Cylinder

Eliminates the need for shock absorbers on air cylinder applications.

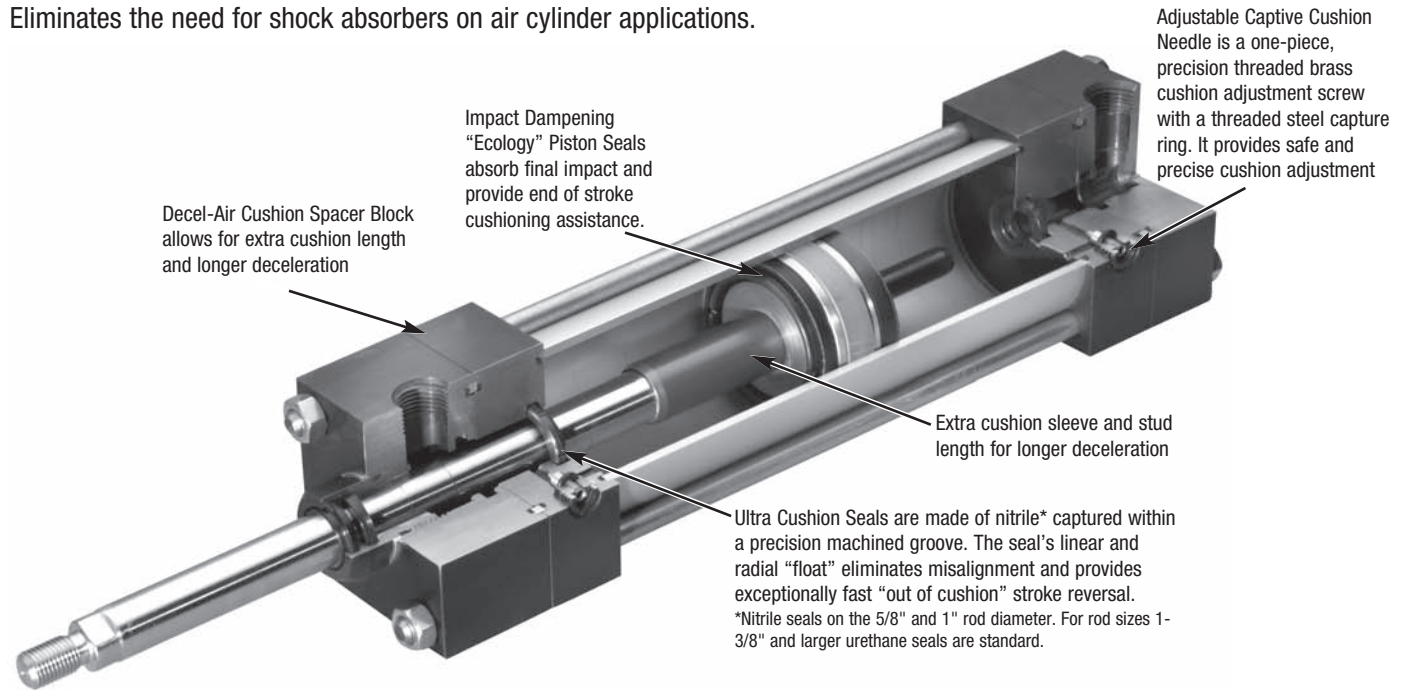

Explanation of Decel-Air Cushion:

Norgren's Decel Cushioned cylinder was designed for applications where high velocity, low mass, material transfer or machine function is required, and where the kinetic energy to be absorbed during cushioning exceeds the parameters of our standard Series EA or EJ air cylinders equipped with non-adjustable or adjustable cushions. Decel cushions employ longer-than-standard air cushions to assist our Impact Dampening Piston Seal.

Why does our Decel-Air Cushion work?

The extra cushion length of the Decel cushioned cylinder provides an additional deceleration capability to slow the cylinder's moving mass to a point where the positive cushioning effect of our Impact Dampening Piston Seals can perform the final cushioning.

Norgren's Decel-Air Cushioned Cylinders Versus Cylinder Mounted Shock Absorbers

The first extensive evaluation of pneumatic cylinder cushion performance was undertaken by the Mechanical Engineering Department of The Ohio State University. The test was conducted on 2-1/2" bore, 12" stroke.

The OSU tests found the Decel Cushioned cylinders absorbed almost three times as much kinetic energy with a lower level of peak cushion as a standard Ecology seal configured cylinder.

Because air is compressible and is exhausted out of the cylinder each cycle, the internal heat buildup is minimized. The **"Maximum Inch Pounds Per Hour"** rating which is essential in determining the effectiveness of shock absorber performance is **not needed** to judge Decel cushion performance.

The test indicated that Norgren Decel-Air Cushioned cylinders could prove to be superior to a hydraulic shock absorber assisted cylinder for high cycle, high velocity applications with light to moderate loading (precisely the area where most severe cylinder applications exist). The cycle rates and the cushioning times of the Decel-Air Cushioned cylinders and the hydraulic shock absorber assisted cylinders were comparable.*

Decel-Air Cushioned cylinders are also less costly than shock absorber mounted cylinders and are self-contained units.

*For comparative evaluation, a well-known hydraulic shock absorber was chosen. The OSU tests showed a smooth shock-absorbing operation was achieved at very low velocities using the shock absorbers, but at comparable Decel Cushion cylinder velocities, a high mechanical impact took place on the shock absorber mounted cylinder.

Potential Decel-Air Cushion Applications

1. Conveyors & Material Handling Equipment
2. Transfer Machines & Shuttle Tables
3. Packaging Machinery
4. Foundry Equipment
5. Automatic Gate Opening & Closing

NFPA Aluminum & Steel Cylinders

The Decel Cushioned cylinder increases the kinetic energy absorption capability by increasing the effective cushion spear length in the cylinder.

The Decel Cushioned cylinder increases the standard cushion spear length by 100%, allowing an increase in kinetic energy absorption capability by two times.

Decel Cushioned Cylinder Fully Cushioned Load Stopping Capacity in Pounds*

In/ Sec	Cylinder Bore										
	1-1/2	2	2-1/2	3-1/4	4	5	6	7	8	10	12
6	558	990	1.798	3.488	5.418	9.370	14.972	20.040	20.858	44.070	72.500
12	136	244	442	860	1.338	2.318	3.708	5.166	7.600	10.892	17.894
18	60	106	190	374	582	1.014	1.620	2.260	3.152	4.748	7.782
24	32	58	104	204	320	558	888	1.244	1.738	2.598	2.828
30	20	36	64	126	198	344	550	774	1.082	1.602	2.606
36	13.4	24	43	84	132	232	366	518	726	1.062	1.712
42	9.4	16.6	29	58	92	162	258	362	514	734	1.176
48	6.8	11.4	20.8	42	66	118	186	262	374	524	830
54	4.6	8.6	10.8	30	48	86	136	194	276	378	590

Piston Rod Dia. Weights*	
5/8"	- .30 lb. + 0.09 lb./in. stroke
1"	- .90 lb. + 0.22 lb./in. stroke
1-3/8"	- 2.2 lb. + 0.42 lb./in. stroke
1-3/4"	- 4.0 lb. + 0.68 lb./in. stroke
2"	- 5.5 lb. + 0.90 lb./in. stroke
2-1/2"	- 10.1 lb. + 1.40 lb./in. stroke

Double Weight for double rod end cylinders

*Include piston rod weight in total load to be stopped.

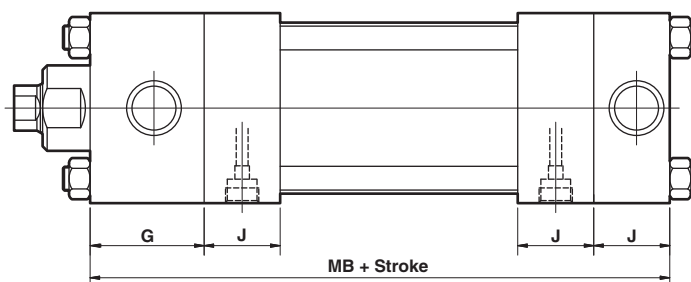

NOTE:

- All dimensions not shown are per STD NFPA dimensions
- For cylinders with (1) Decel Cushion AOL dimension will be "MB"- "J".

Decel Cushioned cylinder envelope dimensions are not NFPA dimensionally interchangeable over the stroke length.

Basic Envelope Dimensions

Cyl. Bore	G	J	Add Stroke MB
1-1/2	1-1/2	1	5-5/8
2	1-1/2	1	5-5/8
2-1/2	1-1/2	1	5-3/4
3-1/4	1-3/4	1-1/4	6-3/4
4	1-3/4	1-1/4	6-3/4
5	1-3/4	1-1/4	7
6	2	1-1/2	8
7	2	1-1/2	8-1/8
8	2	1-1/2	8-1/8

NFPA Aluminum & Steel Cylinders

Cylinder Order Information

EJ 01 7 7 A 1 - HR-L(14)-MS-P(1/4) V - 2" x 6"

→ Bore and Stroke (write out)

Series

Series A Cylinder (Aluminum)	A
Series A Double Rod End Cylinder	DA
Series EA Cylinder	EA
Series EA Double Rod End Cylinder	EDA
Series J Cylinder (Steel)	J
Series J Double Rod End Cylinder	DJ
Series EJ Cylinder	EJ
Series EJ Double Rod End Cylinder	EDJ

Mounting Options

Side Tapped (MS4)	01
Head Rectangular Flange (MF1)	03
Head Square (ME3) - 7" & 8" Bores	03
Cap Rectangular Flange (MF2)	04
Cap Square (ME4) - 7" & 8" Bores	04
Basic Cylinder No Mounting (MX0)	05
Both Ends (4) Tie Rods Ext. (MX1)	06
Both Ends (2) Tie Rods Ext. (MX4)	6B
Cap Tie Rods Ext. (MX2)	6C
Head Tie Rods Ext. (MX3)	6R
Removable Head Trunnion (MT1) - A & EA	7R
Head Trunnion (MT1) - J & EJ	07
Removable Cap Trunnion (MT2) - A & EA	8R
Cap Trunnion (MT2) - J & EJ	08
Side Lugs (MS2)	09
Center Trunnion (MT4)	10
Side End Angles (MS1)	11
Cap Fixed Clevis (MP1)	12
Side End Lugs (MS7)	15
Sleeve Nut Construction (Universal)	16
Head Square Flange (MF5)	20
Cap Square Flange (MF6)	21
Detachable Cap Clevis (MP2)	22
Cap Fixed Eye (MP3)	32
Detachable Cap Eye (MP4)	42
Spherical Bearing	52
Base Bar (Not NFPA A & EA Only)	60

Cushion in Head

None	3
Non-Adjustable Cushion	†5
Adjustable Cushion (Position 2)	7
Decel Cushion	9

† Standard with EA & EJ

Cushion in Cap

None	3
Non-Adjustable Cushion	†5
Adjustable Cushion (Position 2)	7
Decel Cushion	9

† Standard with EA & EJ

Port and Cushion Adjustment Positions
(As viewed from rod end: Port standard position 1, Cushion Adjustment standard position 2.)
NOTE: A Port and a Cushion Adjustment cannot be in the same position.

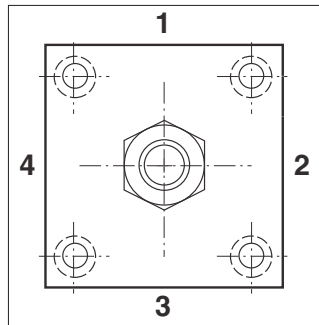

Additional Options – order alphabetically

Case Hardened (50 Rc)	HR
Port Location position 1 standard: L(Head Cap) (specify position 1 thru 4 for head and/or cap)	L()
Rod Lock (passive)	LE
Low Friction	LF
Stroke Adjustment	A
Metal Rod Scraper	MS
Cushion Adjust Screw Location position 2 standard: N(Head Cap) (specify position 1 thru 4 for head and/or cap)	N()
Non-Standard Port Sizes: [specify port size for P(L,H) head only, P(C) cap only, or P() both head & cap]	*P()
Magnetic Piston – includes aluminum tube option - J & EJ	PS
Rod Stud	RS
Rod Extensions (specify length of additional rod extension)	RX
Stainless Steel tie-rods	S
303 Stainless Steel (Hard Chrome Plated)	SS
Stainless Steel bushing	SB
Stop Tube (Rod End) (specify stop tube length)	ST(R)
Special Rod Threads (specify rod thread)	T
Thread Extensions (specify length of thread extension)	TX
Viton® Seals	V

Piston Rod Threads

Type	Dim ref
Small Male (Solid) (std)	KK
Intermediate Thread Male (Solid)	CC
Female	KK
Full Thread Male (Solid)	FF
Plain Rod End	-

Cyl bore	rod ltr.	rod dia. (mm)	Cyl bore	rod ltr.	rod dia. (mm)
1-1/2	A	5/8	6	C	1-3/8
2	B+	1		D	1-3/4
	A	5/8		E	2
2-1/2	B	1	7	F	2-1/2
	C	1-3/8		C	1-3/8
	D+	1-3/4		D	1-3/4
3-1/4	B	1	8	E	2
	C	1-3/8		F	2-1/2
	D	1-3/4		C	1-3/8
4	B	1	10	D	1-3/4
	C	1-3/8		E	2
	D	1-3/4		F	2-1/2
5	E	2	12	D	1-3/4
	F	2-1/2		E	2
	B	1		F	2-1/2

Notes

+ Head cushion not available on these bore and piston rod combinations.
Additional rod sizes available upon request.
Dimensions for thread sizes available on following pages.

NFPA Aluminum & Steel Cylinders

NFPA Series A Aluminum & J Steel Cylinders

1-1/2 to 12 inch bore size

A, EA, J, and EJ Standard and special cylinder options

Option Code	Description
A(-)	Stroke adjustment single piston (specify adjustment length)
AA(-)	Stroke adjustment double piston (specify adjustment length)
AN	Acorn tie rod nuts (stainless steel)
AP	Air/Oil piston (piston supplied with O-ring hooded U-cup on cap end for air/oil operation)
BL	Removable piston rod stud (installed with removable adhesive sealant)
EN**	Electroless nickel plated cylinder
EV(- -)	Pneumatic stroke signal valve(s): EV(Head Cap) (specify position)
FG	Black fiberglass cylinder tube
H	Piston rod seals O-ring loaded U-cups - (A & J Only)
HR	Case hardened piston rod
L(- -)	Non-standard port location position 1 standard: L (Head Cap) (specify position 1 thru 4 for head and/or cap)
LD	Rodlock with manual release
LE	Rodlock
LF	Low friction cylinder (Nitrile compounded with Teflon® rod and piston seals) (Not available with Ecology series)
MS	Metal scraper
N(- -)	Cushion adjust screw location position 2 standard:N(Head Cap) (specify position 1 thru 4 for head and/or cap)
P(-)	Non-standard port sizes - [specify port size for P(-H) head only, P(-C) cap only, or P(-) both head & cap]
PP	Seals in cylinder O-ring loaded U-cups (rod and piston seals) - (A & J Only)
PN	Pinned piston and rod assembly
PS	Magnetic piston modification
RS	Studded male piston rod end
RX(-)	Piston rod extension over standard (specify additional "C" length)
S	303/304 Stainless steel tie rods & nuts
SB	Stainless steel rod bushing nut
SC†	Single acting spring extend cap end of cylinder
SL	Steel cylinder tubing
SR†	Single acting spring retract rod end of cylinder
SS	303 Stainless steel piston rod
ST(-C)	Stop tube on cap end (C) of cylinder: ST (stop tube length C)
ST(-R)	Stop tube on rod end (R) of cylinder: ST (stop tube length R)
SV(- -)	Stroke signal valve(s): SV (head cap)
T(-)	Non-standard piston rod thread (specify thread)
TF(-)	Piston rod thread depth over standard (Female) (specify additional "A" length)
TS	Stainless cylinder tubing
TX(-)	Piston rod thread extension over standard (Male) (specify additional "A" length)
UB*	Head and cap bumpers (Adds 1/4" per bumper to overall length)
UC*	Cap bumper (Adds 1/4" per bumper to overall length)
UH*	Head bumper (Adds 1/4" per bumper to overall length)
V	Viton® seals in cylinder
XI(-)	Type #10 trunnion set dimension (MT4 model only) (customer must specify length)

†Standard available for 1 1/2", 2", 2-1/2" bores, 12" max stroke. (Stroke length doubles - 24" max); 12 lbs. force preload, 30 lbs. force compressed. Cushions not available on spring end. For other spring forces, bore sizes or longer strokes, consult factory.

*UA Unit Air Assembly

** When ordering "EN" option specify S, SS, TS, and SB options.

Consult Factory for These Options:

Option Code	Description
AS	Airsaver stroke adjustment
BB	Cylinders mounted back to back
CT	Close tolerance on cylinder stroke
LA	Low friction cylinder (Pak-Lap™ style seals)
NI	Nituff® coated cylinder
NS	No silicone used in cylinder assembly
OE	Zero stroke/pneumatic stroke signal valve(s)
OV	Zero stroke/stroke signal valve(s)
RB	Rod boot over piston rod
TE	Nituff® coated cylinder tubing
TK	Thrust key plate mounting - J01 (MS4), 09 (MS2), and 15 (MS7)
VM	Valve mounting only

NFPA Aluminum & Steel Cylinders

NFPA (MX0) 05 Basic Mount

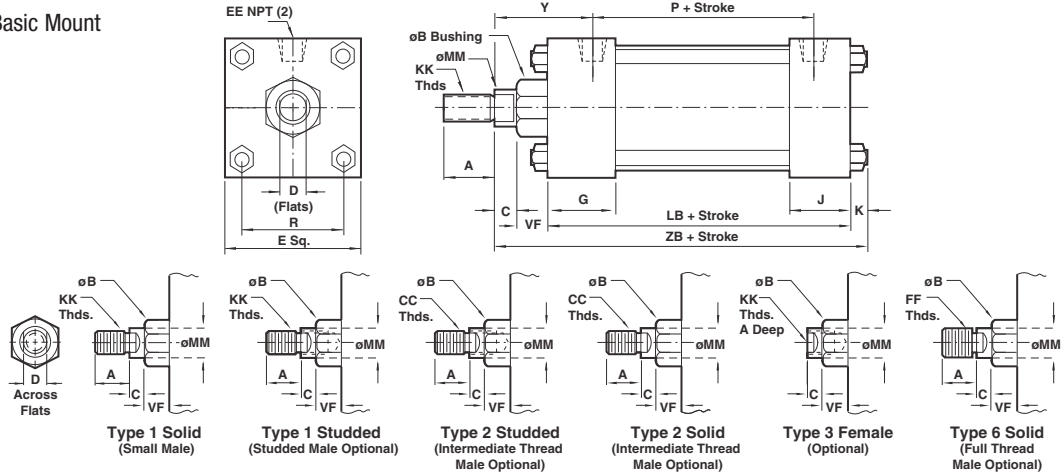

Bore		1-1/2"	2"	2-1/2"	3-1/4"	4"	5"	6"	7"	8"	10"	12"
ø Rod Std.		5/8"	5/8"	5/8"	1"	1"	1"	1-3/8"	1-3/8"	1-3/8"	1-3/4"	2"
MM O.S.		1"	1"	1"	1-3/8"	1-3/8"	1-3/8"	1-3/4"	1-3/4"	1-3/4"	2"	2-1/2"
A Std.		.750	.750	.750	1.125	1.125	1.125	1.625	1.625	1.625	2.000	2.250
O.S.		1.125	1.125	1.125	1.625	1.625	1.625	2.000	2.000	2.000	2.250	3.000
B +.000 Std.		1.124	1.124	1.124	1.499	1.499	1.499	1.999	1.999	1.999	2.374	2.624
-.002 O.S.		1.499	1.499	1.499	1.999	1.999	1.999	2.374	2.374	2.374	2.624	3.124
C Std.		.375	.375	.375	.500	.500	.500	.625	.625	.625	.750	.875
O.S.		.500	.500	.500	.625	.625	.625	.750	.750	.750	.875	1.000
CC Std.		1/2 - 20	1/2 - 20	1/2 - 20	7/8 - 14	7/8 - 14	7/8 - 14	1-1/4 - 12	1-1/4 - 12	1-1/4 - 12	1-1/2 - 12	1-3/4 - 12
O.S.		7/8 - 14	7/8 - 14	7/8 - 14	1-1/4 - 12	1-1/4 - 12	1-1/4 - 12	1-1/2 - 12	1-1/2 - 12	1-1/2 - 12	1-3/4 - 12	2-1/4 - 12
D Std.		.500	.500	.500	.813	.813	.813	1.125	1.125	1.125	1.500	1.688
O.S.		.813	.813	.813	1.125	1.125	1.125	1.500	1.500	1.500	1.688	2.063
E Std.		2.000	2.500	3.000	3.750	4.500	5.500	6.500	7.500	8.500	10.625	12.750
EE Std.		.375	.375	.375	.500	.500	.500	.750	.750	.750	1.000	1.000
FF Std.		5/8-18	5/8-18	5/8-18	1 - 14	1 - 14	1 - 14	1-3/8-12	1-3/8-12	1-3/8-12	1-3/4-12	2-12
O.S.		1 - 14	1 - 14	1 - 14	1-3/8-12	1-3/8-12	1-3/8-12	1-3/4-12	1-3/4-12	1-3/4-12	2-12	2-1/2-12
G Std.		1.500	1.500	1.500	1.750	1.750	1.750	2.000	2.000	2.000	2.250	2.250
J Std.		1.000	1.000	1.000	1.250	1.250	1.250	1.500	1.500	1.500	2.000	2.000
K Std.		.250	.313	.313	.375	.375	.438	.438	.563	.563	.688	.688
KK Std.		7/16 - 20	7/16 - 20	7/16 - 20	3/4 - 16	3/4 - 16	3/4 - 16	1 - 14	1 - 14	1 - 14	1-1/4 - 12	1-1/2 - 12
O.S.		3/4 - 16	3/4 - 16	3/4 - 16	1 - 14	1 - 14	1 - 14	1-1/4 - 12	1-1/4 - 12	1-1/4 - 12	1-1/2 - 12	1-7/8 - 12
LB Std.		3.625	3.625	3.750	4.250	4.250	4.500	5.000	5.125	5.125	6.375	6.875
P Std.		2.340	2.340	2.470	2.690	2.690	2.940	3.125	3.250	3.250	4.125	4.625
R Std.		1.428	1.838	2.192	2.758	3.323	4.101	4.87	5.730	6.442	8.004	9.4069
VF Std.		.625	.625	.625	.875	.875	.875	1.000	1.000	1.000	1.125	1.125
O.S.		.875	.875	.875	1.000	1.000	1.000	1.125	1.125	1.125	1.125	1.250
Y Std.		1.840	1.840	1.840	2.380	2.380	2.380	2.813	2.813	2.813	3.125	3.250
O.S.		2.220	2.220	2.220	2.630	2.630	2.630	3.063	3.063	3.063	3.250	3.500
ZB Std.		4.875	4.938	5.063	6.000	6.000	6.313	7.063	7.313	7.313	8.938	9.563
O.S.		5.250	5.313	5.438	6.250	6.250	6.563	7.313	7.563	7.563	9.063	9.813

All dimensions ± .015 unless otherwise noted.

NFPA (MS4) 01 Side Tapped Mount

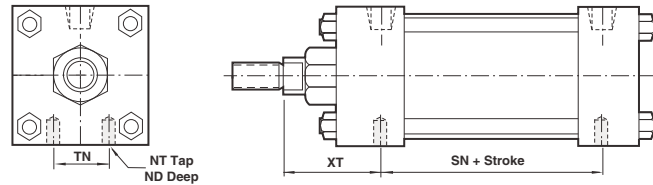

Bore		1-1/2"	2"	2-1/2"	3-1/4"	4"	5"	6"	7"	8"	10"	12"
ND Std.		.375	.375	.500	.750	.750	.938	1.125	1.125	1.125	1.500	1.500
NT Std.		1/4 - 20	5/16 - 18	3/8 - 16	1/2 - 13	1/2 - 13	5/8 - 11	3/4 - 10	3/4 - 10	3/4 - 10	1 - 8	1 - 8
SN Std.		2.250	2.250	2.375	2.625	2.625	2.875	3.125	3.250	3.250	4.125	4.625
TN Std.		.625	.875	1.250	1.500	2.063	2.688	3.250	3.500	4.500	5.500	7.250
XT Std.		1.938	1.938	1.938	2.438	2.438	2.438	2.813	2.813	2.813	3.125	3.250
O.S.		2.313	2.313	2.313	2.688	2.688	2.688	3.063	3.063	3.063	3.250	3.500

All dimensions ± .015 unless otherwise noted.

NFPA Aluminum & Steel Cylinders

NFPA (MF1) 03 Head Rectangular Flange Mount

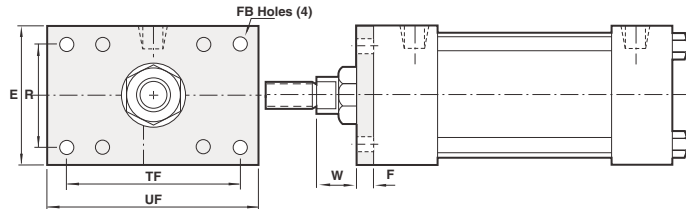

Bore	1-1/2"	2"	2-1/2"	3-1/4"	4"	5"	6"
E	2.000	2.500	3.000	3.750	4.500	5.500	6.500
F	.375	.375	.375	.625	.625	.625	.750
FB	.313	.375	.375	.438	.438	.563	.563
R	1.428	1.838	2.192	2.758	3.323	4.101	4.879
TF	2.750	3.375	3.875	4.688	5.438	6.625	7.625
UF	3.375	4.125	4.625	5.500	6.250	7.625	8.625
W Std.	.625	.625	.625	.750	.750	.750	.875
O.S.	1.000	1.000	1.000	1.000	1.000	1.000	1.125

All dimensions ± .015 unless otherwise noted.

NFPA (MF2) 04 Cap Rectangular Flange Mount

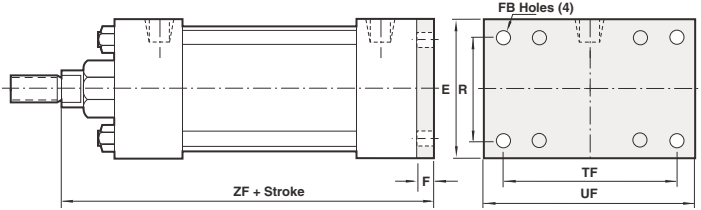

Bore	1-1/2"	2"	2-1/2"	3-1/4"	4"	5"	6"
E	2.000	2.500	3.000	3.750	4.500	5.500	6.500
F	.375	.375	.375	.625	.625	.625	.750
R	1.428	1.838	2.192	2.758	3.323	4.101	4.879
TF	2.750	3.375	3.875	4.687	5.438	6.625	7.625
UF	3.375	4.125	4.625	5.500	6.250	7.625	8.625
ZF Std.	5.000	5.000	5.125	6.250	6.250	6.500	7.375
O.S.	5.375	5.375	5.500	6.500	6.500	6.750	7.625

All dimensions ± .015 unless otherwise noted.

NFPA (ME3) 03 Head Square Mount

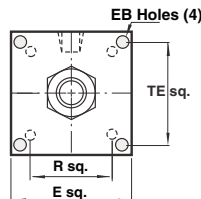

Bore	7"	8"	10"	12"
E	7.500	8.500	10.625	12.750
EB	.563	.688	.813	.813
R	5.730	6.442	8.004	9.406
TE	6.750	7.570	9.406	11.109

All dimensions ± .015 unless otherwise noted.

NFPA (ME4) 04 Cap Square Mount

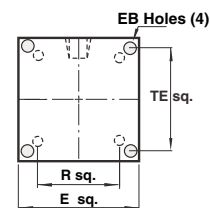

Bore	7"	8"	10"	12"
E	7.500	8.500	10.625	12.750
EB	.563	.688	.813	.813
R	5.730	6.442	8.004	9.406
TE	6.750	7.570	9.406	11.109

All dimensions ± .015 unless otherwise noted.

NFPA (MX1) 06 (4) Extended Tie Rods Both Ends Mount

NFPA (MX2) 6C Cap Tie Rods Extended Mount

NFPA (MX3) 6R Head Tie Rods Extended Mount

NFPA (MX4) 6B (2) Extended Tie Rods Both Ends Mount

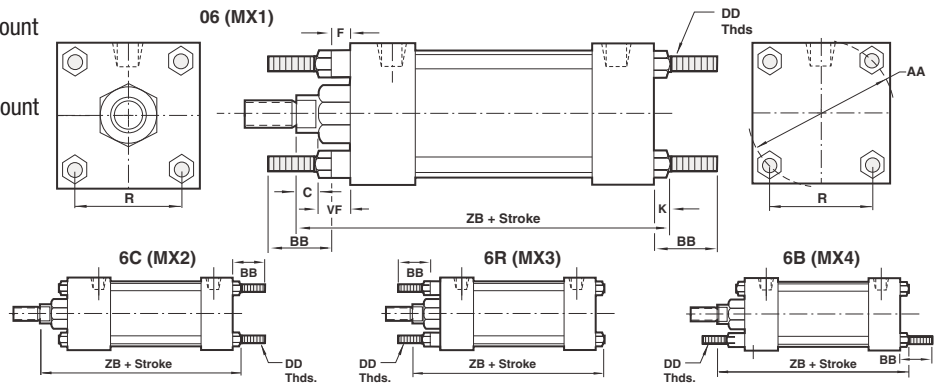

Bore	1-1/2"	2"	2-1/2"	3-1/4"	4"	5"	6"	7"	8"	10"	12"
AA	2.020	2.600	3.100	3.900	4.700	5.800	6.900	8.100	9.100	11.313	13.313
BB	1.000	1.125	1.125	1.375	1.375	1.813	1.813	2.313	2.313	2.688	2.688
C Std.	.375	.375	.375	.500	.500	.500	.625	.625	.625	.750	.875
O.S.	.500	.500	.500	.625	.625	.625	.750	.625	.750	.875	1.000
DD	1/4 - 28	5/16 - 24	5/16 - 24	3/8 - 24	3/8 - 24	1/2 - 20	1/2 - 20	5/8 - 18	5/8 - 18	3/4 - 16	3/4 - 16
F	.375	.375	.375	.625	.625	.625	.750	—	—	—	—
K	.250	.313	.313	.375	.375	.438	.438	.563	.563	.688	.688
R	1.428	1.838	2.192	2.758	3.323	4.101	4.879	5.730	6.442	8.004	9.406
VF Std.	.625	.625	.625	.875	.875	.875	1.000	1.000	1.000	1.125	1.125
O.S.	.875	.875	.875	1.000	1.000	1.000	1.125	1.125	1.125	1.125	1.250
ZB Std.	4.875	4.938	5.063	6.000	6.000	6.313	7.063	7.313	7.313	8.938	9.563
O.S.	5.250	5.313	5.438	6.250	6.250	6.563	7.313	7.563	7.563	9.063	9.813

All dimensions ± .015 unless otherwise noted.

NFPA Aluminum & Steel Cylinders

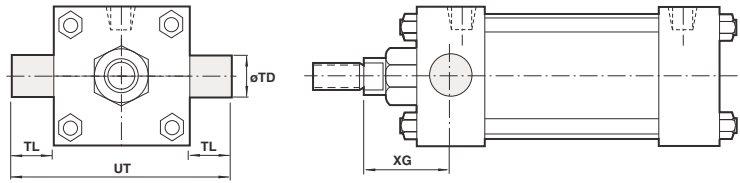
NFPA (MT1) 7R & 07 Head Trunnion Mount

Bore	1-1/2"	2"	2-1/2"	3-1/4"	4"	5"	6"	7"	8"	10"	12"
TD +.000 -0.001	1.000	1.000	1.000	1.000	1.000	1.000	1.375	1.375	1.375	1.750	1.750
TL	1.000	1.000	1.000	1.000	1.000	1.000	1.375	1.375	1.375	1.750	1.750
UT	4.000	4.500	5.000	5.750	6.500	7.500	9.250	10.250	11.250	14.125	16.250
XG Std.	1.750	1.750	1.750	2.250	2.250	2.250	2.625	2.625	2.625	3.000	3.125
O.S.	2.125	2.125	2.125	2.500	2.500	2.500	2.875	2.875	2.875	3.125	3.375

All dimensions ± .015 unless otherwise noted.

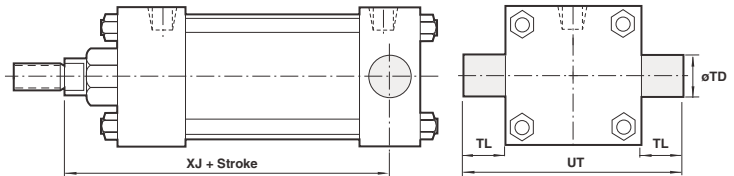
NFPA (MT2) 8R & 08 Cap Trunnion Mount

Bore	1-1/2"	2"	2-1/2"	3-1/4"	4"	5"	6"	7"	8"	10"	12"
TD +.000 -0.001	1.000	1.000	1.000	1.000	1.000	1.000	1.375	1.375	1.375	1.750	1.750
TL	1.000	1.000	1.000	1.000	1.000	1.000	1.375	1.375	1.375	1.750	1.750
UT	4.000	4.500	5.000	5.750	6.500	7.500	9.250	10.250	11.250	14.125	16.250
XJ Std.	4.125	4.125	4.250	5.000	5.000	5.250	5.875	6.000	6.000	7.250	7.875
O.S.	4.500	4.500	4.625	5.250	5.250	5.500	6.125	6.250	6.250	7.375	8.125

All dimensions ± .015 unless otherwise noted.

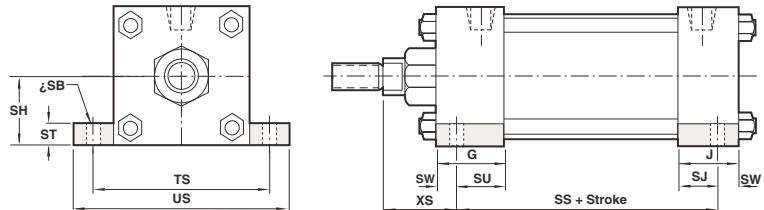
NFPA (MS2) 09 Side Lug Mount

Bore	1-1/2"	2"	2-1/2"	3-1/4"	4"	5"	6"	7"	8"	10"	12"
G	1.500	1.500	1.500	1.750	1.750	1.750	2.000	2.000	2.000	2.250	2.250
J	1.000	1.000	1.000	1.250	1.250	1.250	1.500	1.500	1.500	2.000	2.000
SB	.438	.438	.438	.563	.563	.813	.813	.813	.813	1.063	1.063
SH	1.000	1.250	1.500	1.875	2.250	2.750	3.250	3.750	4.250	5.313	6.375
SJ	.625	.625	.625	.750	.750	.813	.813	.813	.813	2.000	2.000
SS	2.875	2.875	3.000	3.250	3.250	3.125	3.625	3.750	3.750	4.625	5.125
ST	.500	.500	.500	.750	.750	1.000	1.000	1.000	1.000	1.250	1.250
SU	1.125	1.125	1.125	1.250	1.250	1.063	1.563	1.563	1.563	2.000	2.000
SW	.375	.375	.375	.500	.500	.688	.688	.688	.688	.875	.875
TS	2.750	3.250	3.750	4.750	5.500	6.875	7.875	8.875	9.875	12.375	14.500
US	3.500	4.000	4.500	5.750	6.500	8.250	9.250	10.250	11.250	14.125	16.250
XS Std.	1.375	1.375	1.375	1.875	1.875	2.062	2.313	2.313	2.313	2.750	2.875
O.S.	1.750	1.750	1.750	2.125	2.125	2.313	2.562	2.563	2.563	2.875	3.125

All dimensions ± .015 unless otherwise noted.

NFPA Aluminum & Steel Cylinders

NFPA (MT4) 10 Center Trunnion Mount

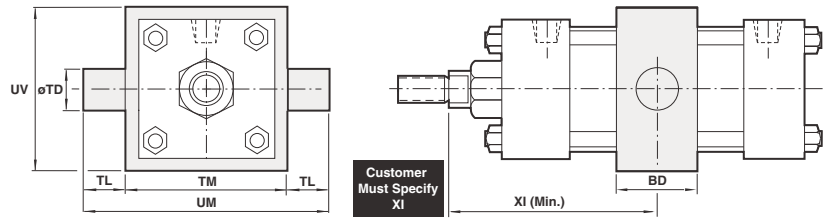

Bore	1-1/2"	2"	2-1/2"	3-1/4"	4"	5"	6"	7"	8"	10"	12"
BD	1.250	1.500	1.500	2.000	2.000	2.000	2.500	2.500	2.500	3.000	3.000
TD $+0.000 -0.001$	1.000	1.000	1.000	1.000	1.000	1.000	1.375	1.375	1.375	1.750	1.750
TL	1.000	1.000	1.000	1.000	1.000	1.000	1.375	1.375	1.375	1.750	1.750
TM	2.500	3.000	3.500	4.500	5.250	6.250	7.625	8.750	9.750	12.000	14.000
UM	4.500	5.000	5.500	6.500	7.250	8.250	10.375	11.500	12.500	15.500	17.500
UV	2.500	3.000	3.500	4.250	5.000	6.000	7.000	8.500	9.500	11.750	13.750
XI min.	Std. 3.125	3.250	3.250	4.125	4.125	4.125	4.625	4.875	4.875	5.625	5.750
	O.S. 3.500	3.625	3.625	4.375	4.375	4.375	4.875	5.125	5.125	5.750	6.000

All dimensions $\pm .015$ unless otherwise noted.

NFPA (MS1) 11 Side End Angle Mount

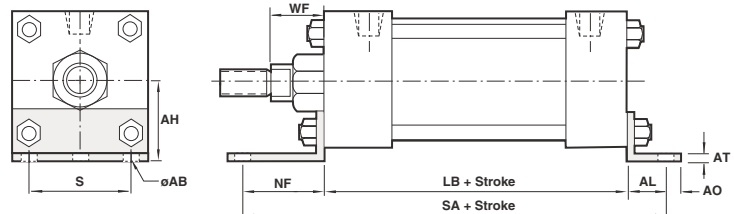

Bore	1-1/2"	2"	2-1/2"	3-1/4"	4"	5"	6"	7"	8"	10"	12"
AB	.438	.438	.438	.563	.563	.688	.813	.813	.813	1.063	1.063
AH	1.188	1.438	1.625	1.938	2.250	2.750	3.250	3.750	4.250	5.313	6.375
AL	1.000	1.000	1.000	1.250	1.250	1.375	1.375	1.813	1.813	2.125	2.125
AO	.375	.375	.375	.500	.500	.625	.625	.688	.688	.875	.875
AT	.125	.125	.125	.125	.125	.187	.187	.250	.250	.250	.250
LB	3.625	3.625	3.750	4.250	4.250	4.500	5.000	5.125	5.125	6.375	6.875
NF	1.375	1.375	1.375	1.875	1.875	2.000	2.125	1.813	1.813	1.813	1.813
S	1.250	1.750	2.250	2.750	3.000	4.250	5.250	6.125	7.125	8.875	11.000
SA	6.000	6.000	6.125	7.375	7.375	7.875	8.500	8.750	8.750	10.625	11.125
WF	STD. 1.000	1.000	1.000	1.375	1.375	1.375	1.625	1.625	1.625	1.875	2.000
	O.S. 1.375	1.375	1.375	1.625	1.625	1.625	1.875	1.875	1.875	2.000	2.250

All dimensions $\pm .015$ unless otherwise noted.

NFPA (MP1) 12 Cap Fixed Clevis Mount

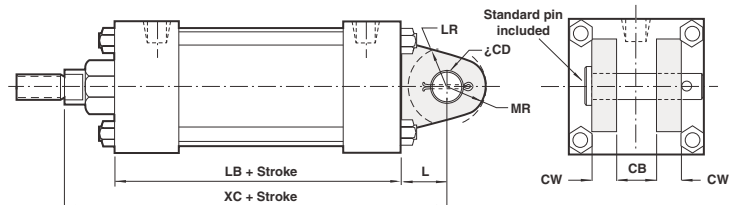

Bore	1-1/2"	2"	2-1/2"	3-1/4"	4"	5"	6"	7"	8"	10"	12"
CB	.750	.750	.750	1.250	1.250	1.250	1.500	1.500	1.500	2.000	2.500
CD	.500	.500	.500	.750	.750	.750	1.000	1.000	1.000	1.375	1.750
CW	.500	.500	.500	.625	.625	.625	.750	.750	.750	1.000	1.250
L	.750	.750	.750	1.250	1.250	1.250	1.500	1.500	1.500	2.125	2.250
LB	3.625	3.625	3.750	4.250	4.250	4.500	5.000	5.125	5.125	6.375	6.875
LR	.750	.750	.750	1.250	1.250	1.250	1.500	1.500	1.500	1.875	2.125
MR	.625	.625	.625	.938	.938	.938	1.188	1.188	1.188	1.625	2.125
XC	Std. 5.375	5.375	5.500	6.875	6.875	7.125	8.125	8.250	8.250	10.375	11.125
	O.S. 5.750	5.750	5.875	7.125	7.125	7.375	8.375	8.500	8.500	10.500	11.375

All dimensions $\pm .015$ unless otherwise noted.

NFPA Aluminum & Steel Cylinders

All dimensions ± .015 unless otherwise noted.

NFPA (MS7) 15 End Lug Mount

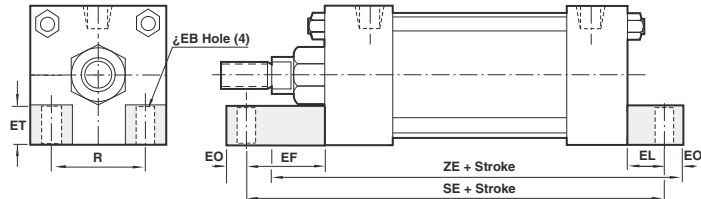

Bore	1-1/2"	2"	2-1/2"	3-1/4"	4"	5"	6"	7"	8"
EB	.313	.375	.375	.438	.438	.563	.563	.688	.688
EF	1.125	1.313	1.438	1.500	1.625	1.688	1.750	1.750	1.750
EL	.750	.938	1.063	.875	1.000	1.063	1.000	1.125	1.125
EO	.250	.313	.313	.375	.375	.500	.500	.625	.625
ET	.500	.750	.750	1.000	1.250	1.500	1.500	1.750	2.063
R	1.428	1.838	2.192	2.758	3.323	4.101	4.879	5.730	6.442
SE	5.500	5.875	6.250	6.625	6.875	7.250	7.750	7.375	7.375
ZE Std.	5.625	5.875	6.125	6.875	7.000	7.438	8.125	8.500	8.500
O.S.	6.000	6.250	6.500	7.125	7.250	7.688	8.375	8.750	8.750

16 Sleeve Nut Construction Side Tapped (Universal Mount)

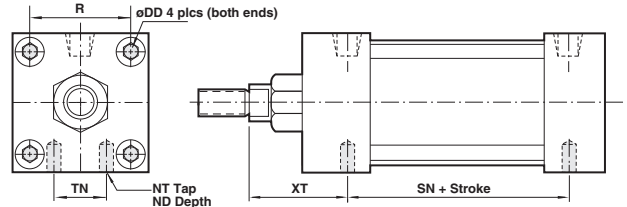

Bore	1-1/2"	2"	2-1/2"	3-1/4"	4"	5"	6"
DD	1/4-28	5/16-24	5/16-24	3/8-24	3/8-24	1/2-20	1/2-20
NT	1/4-20	5/16-18	3/8-16	1/2-13	1/2-13	5/8-11	3/4-10
ND	.375	.375	.500	.750	.750	.938	1.125
R	1.428	1.838	2.192	2.758	3.323	4.101	4.879
SN	2.250	2.250	2.375	2.625	2.625	2.875	3.125
TN	.625	.875	1.250	1.500	2.063	2.688	3.250
XT Std.	1.938	1.938	1.938	2.438	2.438	2.438	2.813
O.S.	2.313	2.313	2.313	2.688	2.688	2.688	3.063

NFPA (MF5) 20 Head Square Flange Mount

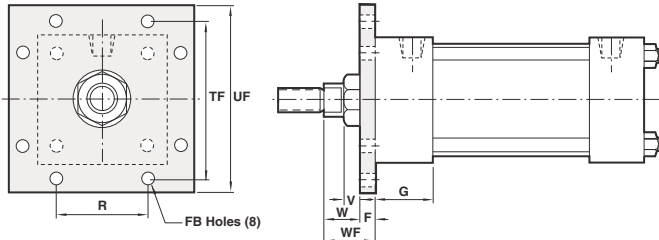

Bore	1-1/2"	2"	2-1/2"	3-1/4"	4"	5"	6"
F	.375	.375	.375	.625	.625	.625	.750
FB	.313	.375	.375	.438	.438	.563	.563
G	1.500	1.500	1.500	1.750	1.750	1.750	2.000
R	1.428	1.838	2.192	2.758	3.323	4.101	4.879
TF	2.750	3.375	3.875	4.688	5.438	6.625	7.625
UF	3.375	4.125	4.625	5.500	6.250	7.625	8.625
V Std.	.250	.250	.250	.250	.250	.250	.250
O.S.	.500	.500	.500	.375	.375	.375	.375
W Std.	.625	.625	.625	.750	.750	.750	.875
O.S.	1.000	1.000	1.000	1.000	1.000	1.000	1.125
WF Std.	1.000	1.000	1.000	1.375	1.375	1.375	1.625
O.S.	1.375	1.375	1.375	1.625	1.625	1.625	1.875

NFPA (MF6) 21 Cap Square Flange Mount

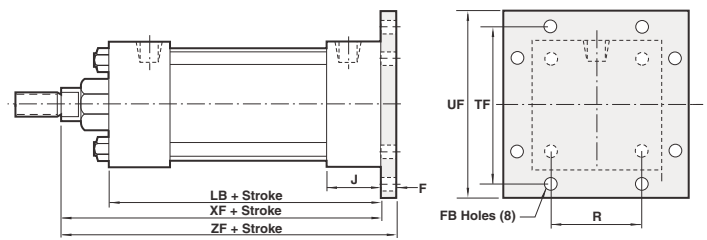

Bore	1-1/2"	2"	2-1/2"	3-1/4"	4"	5"	6"
F	.375	.375	.375	.625	.625	.625	.750
FB	.313	.375	.375	.438	.438	.563	.563
J	1.000	1.000	1.000	1.250	1.250	1.250	1.500
LB	3.625	3.625	3.750	4.250	4.250	4.500	5.000
R	1.428	1.838	2.192	2.758	3.323	4.101	4.879
TF	2.750	3.375	3.875	4.688	5.438	6.625	7.625
UF	3.375	4.125	4.625	5.500	6.250	7.625	8.625
XF Std.	4.625	4.625	4.750	5.625	5.625	5.875	6.625
O.S.	5.000	5.000	5.125	5.875	5.875	6.125	6.875
ZF Std.	5.000	5.000	5.125	6.250	6.250	6.500	7.375
O.S.	5.375	5.375	5.500	6.500	6.500	6.750	7.625

NFPA (MP2) 22 Detachable Cap Clevis Mount

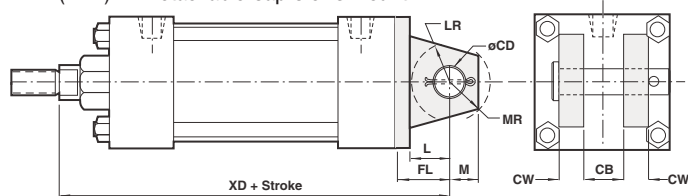

Bore	1-1/2"	2"	2-1/2"	3-1/4"	4"	5"	6"	7"	8"
CB	.750	.750	.750	1.250	1.250	1.500	1.500	1.500	1.500
CD	.500	.500	.500	.750	.750	1.000	1.000	1.000	1.000
CW	.500	.500	.500	.625	.625	.625	.750	.750	.750
FL	1.125	1.125	1.125	1.875	1.875	1.875	2.250	2.250	2.250
L	.750	.750	.750	1.250	1.250	1.500	1.500	1.500	1.500
LR	.750	.750	.750	1.250	1.250	1.500	1.500	1.500	1.500
M	.500	.500	.500	.750	.750	.750	1.000	1.000	1.000
MR	.625	.625	.625	.938	.938	.938	1.188	1.188	1.188
XD Std.	5.750	5.750	5.875	7.500	7.500	8.875	9.000	9.000	9.000
O.S.	6.125	6.125	6.250	7.750	7.750	8.000	9.125	9.250	9.250

NFPA (MP4) 42 Detachable Cap Eye Mount

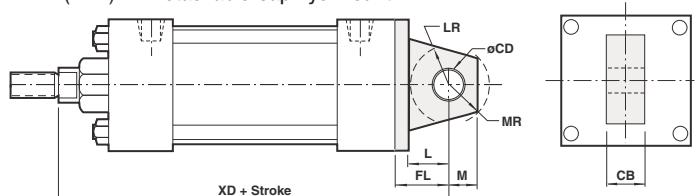

Bore	1-1/2"	2"	2-1/2"	3-1/4"	4"	5"	6"	7"	8"
CB	.750	.750	.750	1.250	1.250	1.500	1.500	1.500	1.500
CD	.500	.500	.500	.750	.750	1.000	1.000	1.000	1.000
FL	1.125	1.125	1.125	1.875	1.875	1.875	2.250	2.250	2.250
L	.750	.750	.750	1.250	1.250	1.500	1.500	1.500	1.500
LR	.750	.750	.750	1.250	1.250	1.500	1.500	1.500	1.500
M	.500	.500	.500	.750	.750	.750	1.000	1.000	1.000
MR	.625	.625	.625	.938	.938	.938	1.188	1.188	1.188
XD Std.	5.750	5.750	5.875	7.500	7.500	7.750	8.875	9.000	9.000
O.S.	6.125	6.125	6.250	7.750	7.750	8.000	9.125	9.250	9.250

NFPA Aluminum & Steel Cylinders

NFPA (MP3) 32 Cap Fixed Eye

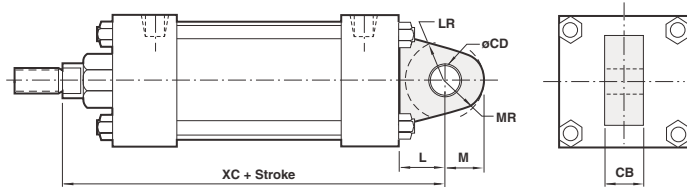

Bore	1-1/2"	2"	2-1/2"	3-1/4"	4"	5"	6"	7"	8"	10"	12"
CB	.750	.750	.750	1.250	1.250	1.250	1.500	1.500	1.500	2.000	2.500
CD	.500	.500	.500	.750	.750	.750	1.000	1.000	1.000	1.375	1.750
L	.750	.750	.750	1.250	1.250	1.250	1.500	1.500	1.500	2.125	2.250
LR	.750	.750	.750	1.250	1.250	1.250	1.500	1.500	1.500	1.875	2.125
M	.500	.500	.500	.750	.750	.750	1.000	1.000	1.000	1.375	1.750
MR	.625	.625	.625	.938	.938	.938	1.188	1.188	1.188	1.625	2.125
XC	Std. 5.375	5.375	5.500	6.875	6.875	7.125	8.125	8.250	8.250	10.375	11.125
	O.S. 5.750	5.750	5.875	7.125	7.125	7.375	8.375	8.500	8.500	10.500	11.375

All dimensions ± .015 unless otherwise noted.

52 (Not NFPA) Spherical Bearing Mount

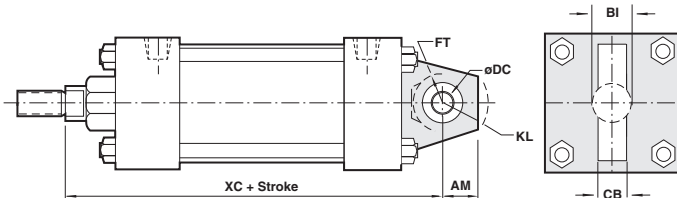

Bore	1-1/2"	2"	2-1/2"	3-1/4"	4"	5"	6"	7"	8"
AM	.750	.750	.750	1.000	1.000	1.000	1.250	1.250	1.250
BI	.438	.438	.438	.656	.656	.656	.875	.875	.875
CB	.375	.375	.375	.562	.562	.562	.75	.75	.75
DC	.500	.500	.500	.750	.750	.750	1.000	1.000	1.000
FT	.625	.625	.625	1.000	1.000	1.000	1.250	1.250	1.250
KL	.969	.969	.969	1.406	1.406	1.406	1.719	1.719	1.719
XC	Std. 5.375	5.375	5.500	6.875	6.875	7.125	8.125	8.250	8.250
	O.S. 5.750	5.750	5.875	7.125	7.125	7.375	8.375	8.500	8.500

All dimensions ± .015 unless otherwise noted.

60 Base (Not NFPA) Bar Mount

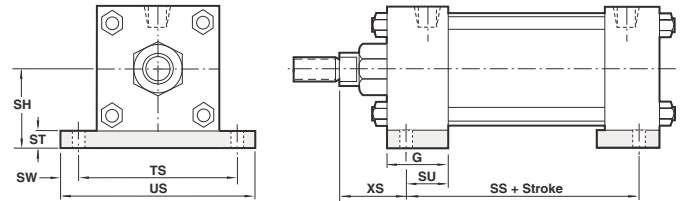

Bore	1-1/2"	2"	2-1/2"	3-1/4"	4"	5"	6"
G	1.500	1.500	1.500	1.750	1.750	1.750	2.000
SH	1.250	1.500	1.875	2.375	2.750	3.500	4.000
SS	2.875	2.875	3.000	3.250	3.250	3.125	3.625
ST	.250	.250	.375	.500	.500	.750	.750
SU	1.125	1.125	1.125	1.250	1.250	1.063	1.313
SW	.375	.375	.375	.500	.500	.688	.688
TS	2.750	3.250	3.750	4.750	5.500	6.875	7.875
US	3.500	4.000	4.500	5.750	6.500	8.250	9.250
XS	Std. 1.375	1.375	1.375	1.875	1.875	2.063	2.313
	O.S. 1.750	1.750	1.750	2.125	2.125	2.313	2.563

All dimensions ± .015 unless otherwise noted.

NFPA (MX0) 05 Basic with Double Rod End Cylinder

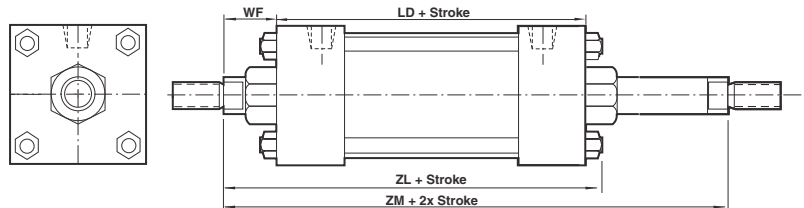

Bore	1-1/2"	2"	2-1/2"	3-1/4"	4"	5"	6"	7"	8"	10"	12"
LD	4.125	4.125	4.250	4.750	4.750	5.000	5.500	5.625	5.625	6.625	7.125
WF	Std. 1.000	1.000	1.000	1.375	1.375	1.375	1.625	1.625	1.625	1.875	2.000
	O.S. 1.375	1.375	1.375	1.625	1.625	1.625	1.875	1.875	1.875	2.000	2.250
ZL	Std. 5.375	5.438	5.563	6.500	6.500	6.813	7.563	7.813	7.813	10.375	11.125
	O.S. 5.750	5.813	5.938	6.750	6.750	7.063	7.813	8.125	8.125	10.625	11.625
ZM	Std. 6.125	6.125	6.250	7.500	7.500	7.750	8.750	8.875	8.875	9.250	9.675
	O.S. 6.875	6.875	7.000	8.000	8.000	8.250	9.250	9.375	9.375	9.375	10.375

All dimensions ± .015 unless otherwise noted.

NFPA Aluminum & Steel Cylinders

All dimensions ± .015 unless otherwise noted.

NFPA Rod Clevis

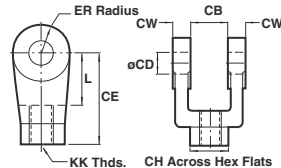

Note: Rod Clevis Assembly 49102A and 49103A are supplied with NFPA Pin. All others are with Standard Pin

Rod Clevis	Rod Clevis Assy.	KK	CB	CD	CE	CH	CW	ER	L
49028	49028A	7/16 - 20	.750	.500	1.500	1.000	.500	.500	.750
49029	49029A	1/2 - 20	.750	.500	1.500	1.000	.500	.500	.750
49097	49097A	5/8 - 18	.750	.500	1.500	1.000	.500	.500	.750
49030	49030A	3/4 - 16	1.250	.750	2.375	1.250	.625	.750	1.250
49098	49098A	7/8 - 14	1.250	.750	2.375	1.250	.625	.750	1.250
49032	49032A	1 - 14	1.500	1.000	3.125	1.500	.750	1.000	1.500
49033	49033A	1-1/4 - 12	2.000	1.375	4.125	2.000	1.000	1.375	2.125
49099	49099A	1-3/8 - 12	2.000	1.375	4.125	2.000	1.000	1.000	2.125
49034	49034A	1-1/2 - 12	2.500	1.750	4.500	2.375	1.250	1.750	2.250
49100	49100A	1-3/4 - 12	2.500	1.750	4.500	2.375	1.250	1.750	2.250
49036	49036A	1-7/8 - 12	2.500	2.000	5.500	2.937	1.250	2.000	2.500
49101	49101A	2 - 12	2.500	2.000	5.500	2.937	1.250	2.000	2.500
49102	49102A	2-1/4 - 12	3.000	2.500	6.500	3.500	1.500	2.750	3.000
49103	49103A	2-1/2 - 12	3.000	3.000	6.750	3.875	1.500	2.750	3.250

Small Rod Clevis & Jam Nut

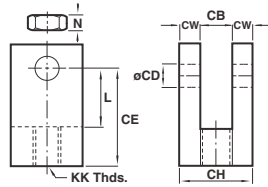

Note: Rod Clevis Assembly is supplied with Jam Nut and Standard Pin.

Rod Clevis	Rod Clevis Assy.	KK	CB	CD	CE	CH	CW	L	N
49218	49218A	1/2 - 20	.500	.500	1.375	1.000	.250	.750	.375
49219	49219A	3/4 - 16	.750	.750	1.750	1.500	.375	1.000	.500

Rod Jam Nut

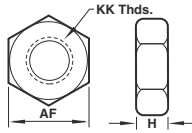

	52025	52026	52027	52010	52029	52030	52085
KK	7/16 - 20	1/2 - 20	5/8 - 18	3/4 - 16	7/8 - 14	1 - 14	1-1/4 - 12
AF	.688	.750	.938	1.125	1.313	1.500	1.875
H	.250	.313	.375	.422	.484	.547	.719
	52092	52068	52082	52070	52093	52083	52075
KK	1-3/8 - 12	1-1/2 - 12	1-3/4 - 12	1-7/8 - 12	2 - 12	2-1/4 - 12	2-1/2 - 12
AF	2.063	2.250	2.625	2.938	3.125	3.500	3.875
H	.781	.844	.969	1.031	1.094	1.203	1.453

NFPA Rod Eye

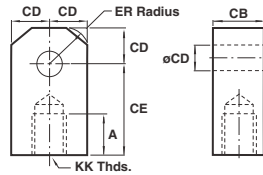

Note: Rod Eye Assembly 49062A and 49096A are supplied with NFPA Pin. All others are supplied with Standard Pin

Rod Eye	Rod Eye Assy.	KK	A	CB	CD	CE	ER
49015	49015A	7/16 - 20	.750	.750	.500	1.500	.563
49014	49014A	1/2 - 20	.750	.750	.500	1.500	.563
49091	49091A	5/8 - 18	.750	1.250	.750	2.063	.500
49013	49013A	3/4 - 16	1.125	1.250	.750	2.063	.938
49092	49092A	7/8 - 14	1.125	1.250	.750	2.063	.750
49011	49011A	1 - 14	1.625	1.500	1.000	2.813	1.125
49010	49010A	1-1/4 - 12	2.000	2.000	1.375	3.438	1.563
49093	49093A	1-3/8 - 12	1.625	2.000	1.375	3.438	1.375
49009	49009A	1-1/2 - 12	2.250	2.500	1.750	4.000	2.500
49094	49094A	1-3/4 - 12	2.250	2.500	1.750	4.000	2.500
49007	49007A	1-7/8 - 12	3.000	2.500	2.000	5.000	2.875
49095	49095A	2 - 12	2.250	2.500	2.000	5.000	2.875
49062	49062A	2-1/4 - 12	3.000	3.000	2.500	5.813	3.250
49096	49096A	2-1/2 - 12	3.000	3.000	3.000	6.125	3.250

Spherical Rod Eye

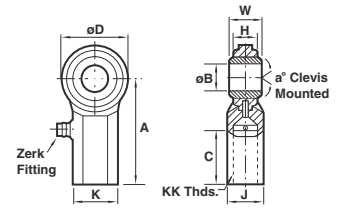

Spherical Rod Eye	49220	49221	49222		
Spherical Rod Eye Assy.	49220A	49221A	49222A		
Bore	1-1/2, 2 & 2-1/2	3-1/4, 4 & 5	6 & 8		
KK	UNF-2B	1/2 - 20	3/4 - 16	1 - 14	
a°	Misalignment Angle	12	14	14	
A		± .015	2.125	2.875	4.125
B		+ .0025 / -.0005	.500	.750	1.000
C		+ .062 / -.031	1.063	1.563	2.125
D		± .010	1.313	1.750	2.750
H	Reference	.453	.593	1.000	
J		± .010	.750	1.000	1.500
K		± .010	.875	1.125	1.625
W		+ .000 / -.005	.625	.875	1.375

NFPA Eye Bracket

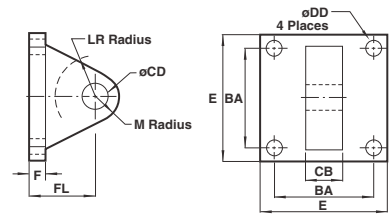

Note: NFPA Eye Bracket Assembly is supplied with Standard Pin.

NFPA Eye Bracket	49021	49020	49019	49016	49017	49018
Eye Bracket Assembly	49021A	49020A	49019A	49016A	49017A	49018A
BA	1.625	2.563	3.250	3.813	4.937	5.750
CB	.750	1.250	1.500	2.000	2.500	2.500
CD	.500	.750	1.000	1.375	1.750	2.000
DD	.406	.531	.656	.656	.906	1.026
E	2.500	3.500	4.500	5.000	6.500	7.500
F	.375	.625	.750	.875	.875	1.000
FL	1.125	1.875	2.250	3.000	3.125	3.500
LR	.750	1.250	1.500	2.125	2.250	2.500
M	.500	.750	1.000	1.375	1.750	2.000

Norgren Eye Bracket

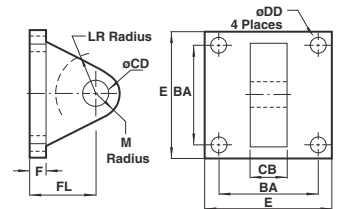

Note: Norgren Eye Bracket Assembly is supplied with Standard Pin.

Norgren Eye Bracket	49240	49241	49242	49243	49244	49019	49016	49017	49018
Assembly	49240A	49241A	49242A	49243A	49244A	49019A	49016A	49017A	49018A
BA	1.438	1.844	2.188	2.938	3.563	3.250	3.813	4.950	5.730
CB	.750	.750	.750	1.250	1.250	1.500	2.000	2.500	2.500
CD	.500	.500	.500	.750	.750	1.000	1.375	1.750	2.000
DD	.281	.344	.344	.469	.469	.656	.656	.906	1.062
E	2.000	2.500	3.000	3.750	4.500	4.500	5.000	6.500	7.500
F	.375	.375	.375	.500	.500	.750	.875	.875	1.000
FL	1.125	1.125	1.125	1.750	1.750	2.250	3.000	3.125	3.500
LR	.563	.563	.563	1.000	1.000	1.500	2.125	2.250	2.500
M	.625	.625	.625	.875	.875	1.000	1.375	1.750	2.000

NFPA Aluminum & Steel Cylinders

NFPA Clevis Bracket

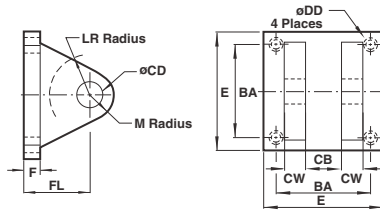

Note: NFPA Clevis Bracket Assembly is supplied with Standard Pin.

NFPA Clevis Bracket	49250	49251	49252
Clevis Bracket Assembly	49250A	49251A	49252A
BA	1.625	2.563	3.250
CB	.750	1.250	1.500
CD	.500	.750	1.000
CW	.500	.625	.750
DD	3/8 - 24	1/2 - 20	5/8 - 18
E	2.500	3.500	4.500
F	.375	.625	.750
FL	1.125	1.875	2.250
LR	.750	1.250	1.500
M	.500	.813	1.000

All dimensions ± .015 unless otherwise noted.

Norgren Clevis Bracket

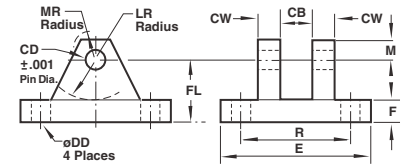

Note: Norgren Clevis Bracket Assembly is supplied with Standard Pin.

Norgren Clevis Bracket	49022	49023	49024	49027	49025	49026
Clevis Bracket Assembly	49022A	49023A	49024A	49027A	49025A	49026A
CB	.750	1.250	1.500	2.000	2.500	2.500
CD	.500	.750	1.000	1.375	1.750	2.000
CW	.500	.625	.750	1.000	1.250	1.500
DD	.406	.531	.656	.656	.906	1.026
E	3.500	5.000	6.500	8.000	10.000	12.000
F	.500	.625	.750	.875	.875	1.000
FL	1.500	1.875	2.250	3.000	3.625	4.520
LR	.750	1.188	1.500	2.000	2.750	3.188
M	.500	.750	1.000	1.375	1.750	2.250
MR	.625	.906	1.250	1.656	2.219	2.781
R	2.547	3.828	4.953	5.734	7.500	9.938

All dimensions ± .015 unless otherwise noted.

NFPA Pin

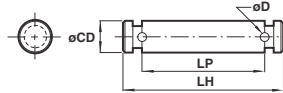

Note: ø.500, .750, 1.000 are Retainer type design ø1.375 and larger are Cotter Pin design.

NFPA Pin	49006-R	49005-R	49004-R	49003	49002	49001	49000	49126	49127
CD	.500	.750	1.000	1.375	1.750	2.000	2.000	2.500	3.000
LH	2.219	3.125	3.750	4.750	5.812	5.812	6.312	6.875	6.875
LP	1.875	2.750	3.250	4.250	5.250	5.281	5.770	6.312	6.344
D	-	-	-	.173	.173	.204	.204	.219	.250

All dimensions ± .015 unless otherwise noted.

Standard Pin

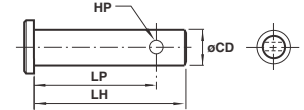

Std. Pin	49207*	49208*	49206	49205	49204	49203	49202	49201
CD	.500	.750	.500	.750	1.000	1.375	1.750	2.000
HP	.156	.156	.156	.156	.203	.250	.250	.250
LH	1.421	2.000	2.250	3.000	3.500	5.000	6.000	6.000
LP	1.266	1.843	2.093	2.843	3.297	4.500	5.500	5.500

All dimensions ± .015 unless otherwise noted.

Rod Alignment Coupler

The Rod Alignment Coupler allows 1/16" of radial float and 2° of spherical movement. This prevents cylinder binding due to misalignment thus extending bearing and seal life, and permits greater tolerance between the centerline of the cylinder and mating part for simplified installation.

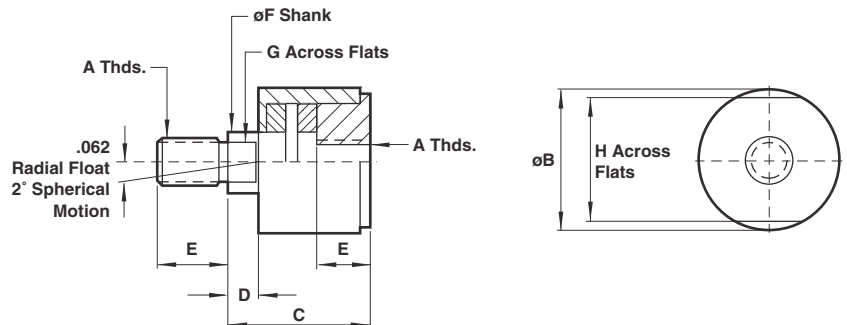

Rod Alignment Coupler Dimensions

	CC-1-07	CC-1-08	CC-1-10	CC-1-12	CC-1-14	CC-1-16	CC-1-20	CC-1-24	CC-1-28
	7/16 - 20	1/2 - 20	5/8 - 18	3/4 - 16	7/8 - 14	1 - 14	1-1/4 - 12	1- 1/2 - 12	1-3/4 - 12
A	1.250 (31.75)	1.250 (31.75)	1.250 (31.75)	1.750 (44.45)	1.750 (44.45)	2.500 (63.50)	2.500 (63.50)	3.250 (82.50)	3.250 (82.50)
B	2.000 (50.80)	2.000 (50.80)	2.000 (50.80)	2.312 (58.72)	2.312 (58.72)	2.937 (74.60)	2.937 (74.60)	4.375 (111.13)	4.375 (111.13)
C	.500 (12.70)	.500 (12.70)	.500 (12.70)	.500 (12.70)	.500 (12.70)	.500 (12.70)	.500 (12.70)	.812 (20.62)	.812 (20.62)
D	.750 (19.05)	.750 (19.05)	.750 (19.05)	1.125 (28.58)	1.125 (28.58)	1.625 (41.28)	1.625 (41.28)	2.250 (57.15)	2.250 (57.15)
E	.625 (28.58)	.625 (28.58)	.625 (28.58)	.969 (24.61)	.969 (24.61)	1.375 (34.93)	1.375 (34.93)	1.750 (44.45)	1.750 (44.45)
F	.500 (12.70)	.500 (12.70)	.500 (12.70)	.812 (20.62)	.812 (20.62)	1.156 (29.36)	1.156 (29.36)	1.500 (38.10)	1.500 (38.10)
G	1.125 (28.58)	1.125 (28.58)	1.125 (28.58)	1.500 (38.10)	1.500 (38.10)	2.250 (57.15)	2.250 (57.15)	3.000 (76.20)	3.000 (76.20)
H	10,000	14,000	19,000	34,000	39,000	64,000	78,000	134,000	134,000

NFPA Aluminum & Steel Cylinders

Air-Oil Tank

Available in 5 practical bore sizes: 1-1/8", 2", 3-1/4", 5", and 8", the Air-Oil Tank includes a translucent fiberglass tube which permits viewing of the tank oil level from any position, internal baffles that reduce foaming and aeration of the system oil resulting in maximum cylinder control, and standard angle mounting brackets (except 1-1/8" bore) easily removed for convenient fluid port positioning.

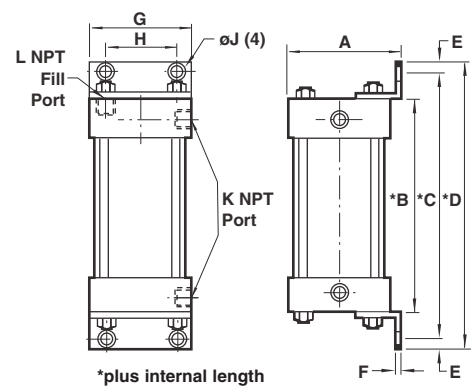
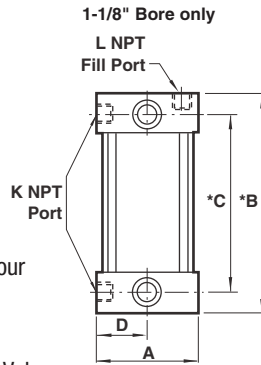

How to Figure Length of Volume

Use these equations to select the right air/oil tank volume for your particular application.

Volume of Cylinder:

- Cap End Cylinder Bore Area x Stroke = Volume
- Head End Cylinder Bore Area - (Piston Rod Area) x Stroke = Volume

$$\text{Length of Tank} = \frac{\text{Volume of Cylinder} \times 1.3^*}{\text{Tank Bore Area}}$$

(See chart below.) *30% minimum recommended reserve working volume.

Final Length of Tank = Working length of tank + 2" minimum safety factor to prevent aeration of oil. Note: Length must be at least 3".

Air-Oil Tank Dimensions

Bore	1-1/8"	2"	3-1/4"	5"	8"
	AOT-225	AOT-04	AOT-065	AOT-10	AOT-16
A	1.500 (38.10)	2.687 (68.25)	4.000 (101.60)	5.625 (142.88)	8.625 (219.08)
B	1.250 (31.75)	2.000 (50.80)	2.500 (63.50)	2.500 (63.50)	3.000 (76.20)
C	.750 (19.05)	4.000 (101.60)	5.000 (127.00)	5.250 (127.00)	6.625 (168.28)
D	.750 (19.05)	4.750 (120.65)	6.000 (152.40)	6.500 (152.40)	8.000 (203.20)
E		.375 (9.53)	.500 (12.70)	.500 (12.70)	.687 (17.45)
F		.125 (3.18)	.187 (4.75)	.187 (4.75)	.250 (6.35)
G		2.500 (63.50)	3.750 (95.25)	5.500 (139.70)	8.500 (215.90)
H		1.750 (44.45)	2.750 (69.85)	4.25 (107.95)	7.125 (180.98)
øJ		.437 (11.10)	.562 (14.27)	.690 (17.53)	.812 (20.62)
K	.125 (3.18)	.375 (9.53)	.500 (12.70)	.500 (12.70)	.750 (19.05)
L	.125 (3.18)	.250 (6.35)	.375 (9.53)	.375 (9.53)	.500 (12.70)

Note: Maximum operating pressure 250 PSI.

Air-Oil Tank Volumes (cubic inches)

Internal Length of Tank	Bore	1-1/8"	2"	3-1/4"	5"	8"
	Area	.995 sq."	3.14 sq."	8.30 sq."	19.64 sq."	50.26 sq."
6"		5.9	18.6	49.8	117.8	301.5
8"		7.9	25.1	66.4	157.1	402.0
10"		9.9	31.4	83.0	196.4	502.6
12"		11.9	37.6	99.6	235.6	603.1
14"		13.9	43.9	116.2	274.9	703.6
16"		15.9	50.2	132.8	314.2	804.1
18"		17.9	56.5	149.4	353.5	904.5
20"		19.9	62.8	166.0	392.8	1005.2

How to Order: Specify air-oil tank part number and internal length.

Example: 2" bore with 6" internal length = AOT-04 x 6

Cylinder Force and Volume Charts

Extend Forces in pounds (newtons)

Bore	Piston Area	PSI (bar)										Volume	
		40 (3)	60 (4)	80 (6)	100 (7)	150 (10)	200 (14)	Cu Ft (cm3)	Displacement Per Inch				
1-1/2"	1.77 (11.40)	71 (315)	106 (472)	142 (629)	177 (786)	266 (1179)	353 (1570)	.00102 (29)					
2"	3.14 (20.27)	126 (559)	189 (839)	251 (1119)	314 (1398)	471 (2097)	628 (2793)	.00182 (52)					
2-1/2"	4.91 (31.67)	196 (874)	295 (1311)	393 (1748)	491 (2185)	737 (3277)	982 (4368)	.00284 (80)					
3-1/4"	8.30 (53.32)	332 (1477)	498 (2215)	664 (2953)	830 (3692)	1245 (5538)	1659 (7379)	.00480 (136)					
4"	12.57 (81.07)	503 (2237)	754 (3355)	1005 (4473)	1257 (5592)	1886 (8388)	2513 (11178)	.00727 (206)					
5"	19.64 (126.71)	785 (3491)	1178 (5240)	1571 (6988)	1964 (8736)	2946 (13104)	3928 (17472)	.01137 (322)					
6"	28.27 (182.39)	1130 (5026)	1696 (7544)	2262 (10061)	2827 (12574)	4240 (18860)	5654 (25149)	.01636 (463)					
7"	38.49 (247.91)	1540 (6831)	2309 (10242)	3079 (13658)	3849 (17074)	5774 (25613)	7698 (34148)	.02227 (631)					
8"	50.26 (324.26)	2010 (8940)	3015 (13411)	4020 (17881)	5026 (22356)	7539 (33533)	10052 (44711)	.02909 (829)					
10"	78.54 (506.74)	3141 (13974)	4712 (20961)	6283 (27948)	7854 (34935)	11781 (52402)	15700 (69834)	.04545 (1282)					
12"	113.10 (729.72)	4524 (20123)	6786 (30184)	9048 (40246)	11310 (50307)	16965 (75460)	22620 (100614)	.06545 (1852)					

All Dimensions in Inches (mm)
All Forces in Pounds (Newtons)

Deduct these Forces for Retract Strokes

Rod	Rod Area	PSI (bar)										Volume	
		40 (3)	60 (4)	80 (6)	100 (7)	150 (10)	200 (14)	Cu Ft (cm3)	Displacement Per Inch				
5/8"	.307 (1.98)	12 (53)	18 (80)	25 (111)	31 (138)	46 (205)	61 (271)	.00018 (5)					
1"	.785 (5.06)	31 (138)	47 (209)	63 (280)	78 (351)	118 (525)	157 (698)	.00045 (13)					
1-3/8"	1.485 (9.58)	59 (262)	89 (396)	119 (529)	149 (663)	222 (997)	297 (1321)	.00086 (24)					
1-3/4"	2.404 (15.51)	96 (423)	144 (641)	192 (854)	240 (1068)	360 (1601)	480 (2135)	.00139 (39)					
2"	3.142 (20.16)	126 (559)	189 (839)	251 (1118)	314 (1398)	471 (2096)	628 (2795)	.00182 (52)					
2-1/2"	4.909 (31.67)	196 (873)	295 (1310)	393 (1747)	491 (2184)	736 (3275)	981 (4367)	.00284 (80)					