

'63 VETTE ROADSTERS



**ADVANCED  
FIBRE-GLAS  
CONCEPTS**

'23 ALTEREDS



'07 MUSTANG ROADSTERS

World Class Glass At Affordable prices



# ALTEREDS, DRAGSTERS & ROADSTERS

CAMARO ROADSTERS



30 SERIES ROADSTERS



20 SERIES ROADSTERS



DRAGSTERS



'57-'58 VETTE ROADSTER



OVER 35 BODY STYLES AVAILABLE ....SEE INSIDE FOR DETAILS



**RICHARD DEARLE'S**  
**SUNCOAST**  
**RACE CARS**  
 QUALITY RACE CARS AND COMPONENTS SINCE 1976  
 6240 S. TEX POINT HOMOSASSA, FL 34448 PHONE: 352-628-5001



# CONTENTS

## DRAGSTERS & ALTEREDS

JR DRAGSTER	4
DRAGSTER	4
JR. FUNNY CAR	4
FIAT TOPOLENO	4
FUEL ALTERED OR ALTERED STYLE "BANTAM"	4
'23 ALTERED	5
'32 BANTAM ROADSTER	5

## 20 SERIES ROADSTERS

20 SERIES - AERO '27	6
20 SERIES - TRADITIONAL '27	6

## 30 SERIES ROADSTERS

30 SERIES - '34 CHEVY, '33 FORD, & '33 DODGE	7
30 SERIES - '38 CHEVY, '37 FORD, & '36 DODGE	7

## VETTE ROADSTERS

'53 -'57 "VETTE"	8
'58 "VETTE"	8
'63 -'67 "VETTE" (STD., NARROW & AERO)	8
2K "VETTE" (STD. & AERO)	9
'05 -'07 "VETTE"	9

## CHEVY ROADSTERS

'57 CHEVY	9
2K CAVALIER	9
'68 -'69 CAMARO	10

## FORD ROADSTERS

'55 -'57 T- BIRD	10
2K MUSTANG	10
'05 -'07 MUSTANG	10
COBRA	11

VIPER ROADSTER pg 12

"TERMS & CONDITIONS" pg 16





# FIBERGLASS BODIES

## HOW NICE IS THIS STUFF?

We picked the following body's for testimonials because of the story behind it. Suncoast had a customer that wanted a C-5 "Vette" and AFC did not have one, so Suncoast had the customer locate one and purchased it. When it arrived it had the usual fiberglass surprise. Repairs hidden under primer, panels didn't fit, big dimension differences from one side to another and so on and so on

After completing the chassis & studying the body it was decided that it would be best to fix the problems with the body (straighten it). Remember that repairs add weight. After straightening there was a plug made this is the first step in the mold process, so after hundreds of hours were invested in this project a mold was finally made and the AFC could produce Quality light weight bodies that shined (a shiny finish is an AFC trademark). Because most fiberglass has a flat finish so it is easier to hide repairs under primer. AFC maintains their molds by rotating them out of service, stripping and resurfacing them to ensure that you the customer receives a finish second to none in the industry.

So this body holds a place in our history and this is why we used the testimonials for it, as this reflects the quality of a AFC body and components.



*Stacy of Race 1 Paint Design* said "The first body looked so nice we thought it was a display body, then we got the second one and it looked as good as the first. We painted the second body black, put it out in the sun for a couple of days so any problems with the body would show up, but none ever did. I've never seen bodies this nice before!!"

**Dan Morrow's Quick 8 2K "Vette"** before and after paint. It won Best Appearing & Best Engineered first time out!! Painted by Stacy of Race 1 Design



*Mike Hartis'*  
2K Quick 8 / Pro Mod "Vette" –  
Mike say's "There's not 2 cups of filler in the whole body."



Mic Lane's awesome looking 2K "Vette" with one of our bodies with a Race 1 Design paint scheme. The first body Race One purchased.



*Torsten Kath* of Germany, sent us pictures of the wildly awesome paint job on his Suncoast Race Cars 2K "Vette" that he said was applied with very little body prep.



*Stefan Giese* of Germany, sent us pictures of his sleek looking Suncoast Race Cars 2K "Vette". With comments about how nice the body was to work with. You can get more info on his car at his web site [www.mrt-](http://www.mrt-)

**CALL OR WATCH FOR OUR ADVERTISEMENTS WITH SPECIALS & DISCOUNTS**

**NEED HELP WITH THAT SPECIAL PROJECT ???**



48 CHEVY Crew Cab for B/G Fuel Systems



Kevin & Mariann Bondy's 2k-3 Mustang stadium truck with flip body & opening doors and 138" WB & 44" tires

**Hard to believe this started out to be a standard 2K-3 Mustang "Pro Stock" style body.**

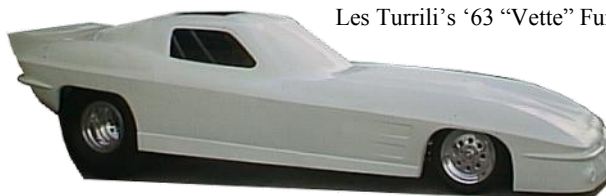

Les Turrili's '63 "Vette" Funny Car



'63 "Vette" Funny Car Rear View

**AFC/SUNCOAST WILL WORK WITH YOU. ABOVE ARE FEW EXAMPLES OF ONE OFF PIECES.**

# DRAGSTERS & ALTEREDS

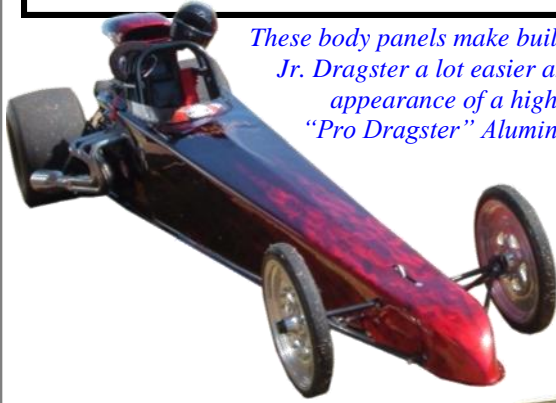

*These body panels make building your kids Jr. Dragster a lot easier and gives the appearance of a high dollar "Pro Dragster" Aluminum Body.*

**JR. DRAGSTER BODIES**

150" WHEELBASE

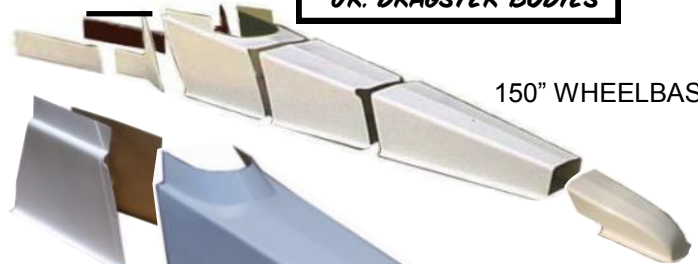

**ONE PIECE DRAGSTER BODIES**

**FULL SIZE DRAGSTER BODIES**

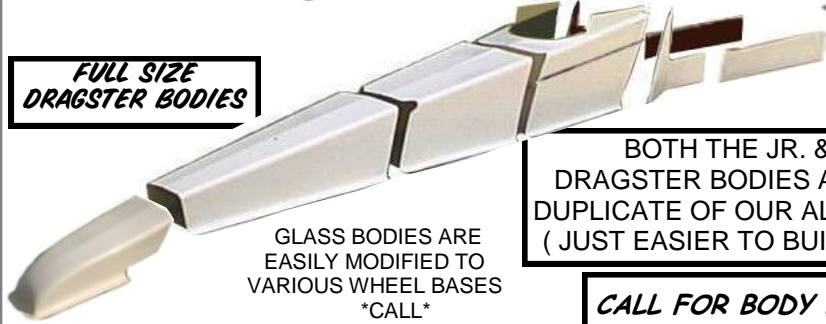

GLASS BODIES ARE EASILY MODIFIED TO VARIOUS WHEEL BASES \*CALL\*

**BOTH THE JR. & FULL SIZE DRAGSTER BODIES ARE THE EXACT DUPLICATE OF OUR ALUMINUM BODIES (JUST EASIER TO BUILD AND PAINT!!!)**

**CALL FOR BODY DRAWINGS & DIMENSION SHEETS**

## JR. FUNNY CARS

OVER ALL LENGTH: 11', WHEELBASE: 82", WIDTH: 40"  
 BODY HEIGHT: FRONT 10", REAR 24"  
 ROOF WIDTH : BOTTOM 31", TOP 22" ROOF HEIGHT: 33"

**-Call or see price sheet-**

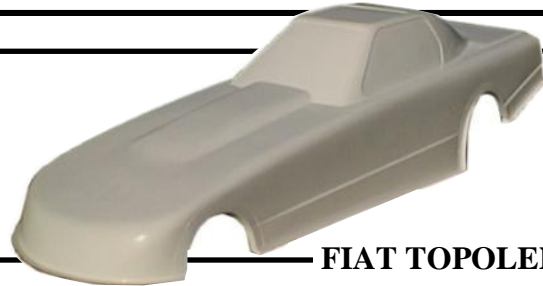

**FIAT TOPOLENO**



ALTERED STYLE FIAT



*You can use these bodies to build everything from a bracket car to a "Nostalgia Fuel Altered" or even mount it on a front engine dragster for a "cool" nostalgic look. We've even seen some outrageous*



**NOSTALGIA STYLE \*FIAT BODY**

**FIAT SEPARATE NOSE / GRILL**

**-Call or see price sheet-**

FIAT BODIED A/FUEL COUPE



**FUEL ALTERED STYLE NOSE WITH INTEGRAL GRILL SHELL**



ROOF "FILLED & CHOPPED" WITH INTEGRAL DOORS

**DRAGSTER ALTERED STYLE BODY WITH INTEGRAL DOORS...FOR RACE OR STREET USE**

**-Call or see price sheet-**

"BANTAM" BODIED A/FUEL COUPE





# ALTEREDS

ALTEREDS

## '23T ALTERED BODY KITS

**CALL FOR BODY DRAWINGS & DIMENSION SHEETS**



Multiple piece Suncoast Altered body shown with optional nose and engine fairing package

INTEGRAL DRIVERS COMPARTMENT

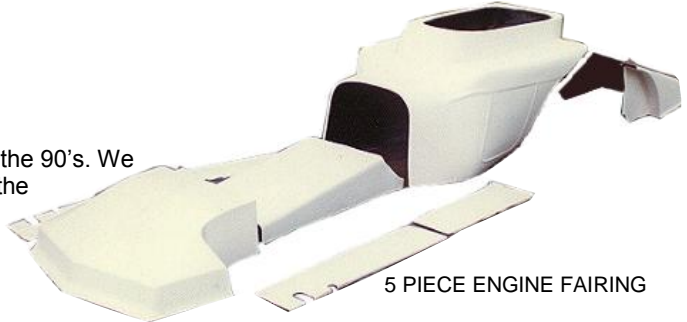

5 PIECE ENGINE FAIRING

AERO / ALTERED NOSE

The Suncoast 23T Altered body has been upgraded to the 90's. We extended the lower body edge approximately 2-1/2". This gives the body a longer, lower, cleaner look. The driver fairing is part of the body making the package lighter as well as saving the customer a considerable amount of money by not having to mold a separate fairing piece into the body like most manufacturers do.

OPTIONS	
* 3 pc body kit w/integral fairing around driver	
* Standard Altered Aero Nose	
* Installation kit for std. Aero Nose	
* Rounded Aero Nose	
* Installation kit for rounded aero nose	
* Fuel Cell Access Door Kit for nose	
* Fairing ahead & around engine from nose to main body	
* Molded 1/8" "No Mar" Lexan windshield (attaches to fairing)	
* Installation of windshield	



SUNCOAST ALTERED WITH AERO NOSE AND ENGINE FAIRING PACKAGE

## '23T ALT

GRILL SHELL (NOT SHOWN, CALL)

Extended cowl

Integral firewall

**1 PIECE '23 ALTERED BODY & GRILL SHELL**  
-Call or see price sheet-



3/4 Front view



3/4 Rear view

Radiused recessed wheel openings

Integral turtle deck

## '23 ALTERED BODY DIMENSIONS

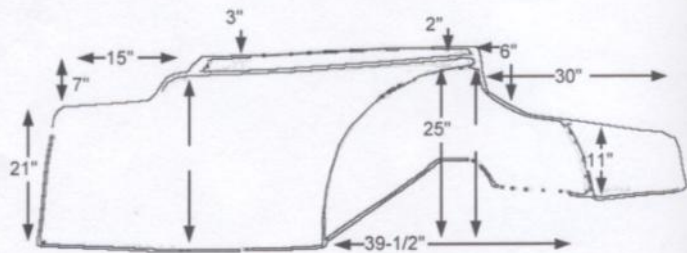
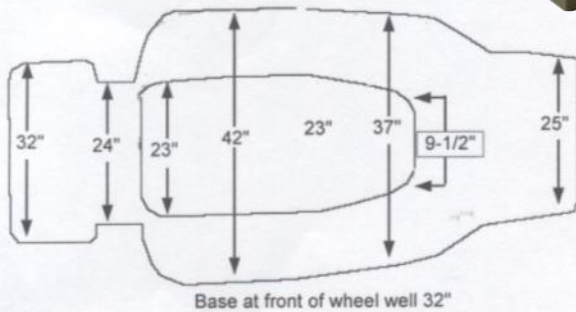

## '32BANTAM ROADSTER

**"NOSTALGIC" STYLE BANTAM ROADSTER BODY**

CENTER STEER  
TONNEAU COVER

COWL EXTENSION  
(NOT SHOWN)

-Call or see price sheet-



**COMP ELIMINATOR "AERO STYLE" BANTAM BODY AVAILABLE**  
(CALL FOR MORE INFORMATION)

# '20 SERIES



Advanced Fibre-Glas Concepts has produced high quality roadster bodies for over 20 years. Working closely with Suncoast Race Cars, Advanced Fibre-Glas Concepts designed roadster bodies with the features that drag racers and pro streeters alike need, such as flanges throughout the components to allow easy assembling and Dzusing of fenders, deck lids, hoods, etc. Advanced Fibre-Glas Concepts roadster bodies have removable passenger side tonneau covers and driver side windshield fairing that can be used as a wind screen (air deflector) or trimmed down to be used as a mounting flange for a Lexan windshield (other than the Aero 27 which has integral tonneau and wing).

Advanced Fibre-Glas Concepts has designed its bodies to accept "OEM" style head lights and tail lights (when possible), and in the 63-67 "Vette" you can even install the factory flip up gas cap that allows easy access to the fuel cell.

Advanced Fibre-Glas Concepts has provided a recess in the front cowl flange for easy installation of the aluminum firewall (in the late model roadsters ('53-2006) . This provides an easy way for the builder to install the firewall.

All Advanced Fibre-Glas Concepts hoods are basically flat for choice of hood scoop and various types of installation. All Advanced Fibre-Glas Concepts front ends are flanged for easy hood Dzusing on the '20-'30 series roadsters the grill shells and fenders are flanged for easy unitizing into 1 pc. Lift off front ends.

All of these features, coupled with anti vortex fairing around the wheel openings, ground effects style rocker panels (the '30 series bodies even have extended and louvered front fenders and extended running board sides, all designs for air management). Combine to give you the most well thought out, highest quality, easy to assemble bodies with the nicest finish available anywhere at any price.

**ROADSTER BODYS HAVE COMPLETELY FLANGED DRIVER COMPARTMENTS, DECK LID OPENINGS & FIREWALLS FOR EASY DZUSING OF WINDSHIELD FAIRINGS, TONNEAU COVERS, DECK LIDS & FRONT END COMPONENTS.**

**All Suncoast/AFC bodies are hand laid in high quality molds with a glossy. "virgin white" gel coat that gives you the highest quality fiberglass components available anywhere.**



## —20 SERIES AERO 27's

Integral tonneau & windshield fairing

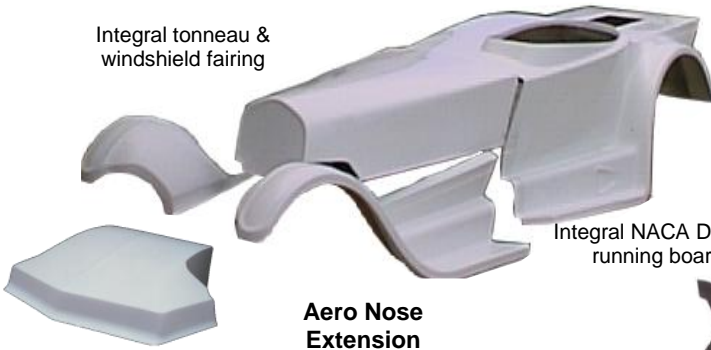

Aero Nose Extension

Integral NACA Ducts in running boards

Rear clip with integral wing and running boards

**27 AERO BODY KIT INCLUDES:**  
Rear body clip with integral wing and removable deck lid, 2 front fenders and hood with integral grill shell  
**-CALL OR SEE PRICE SHEET-**

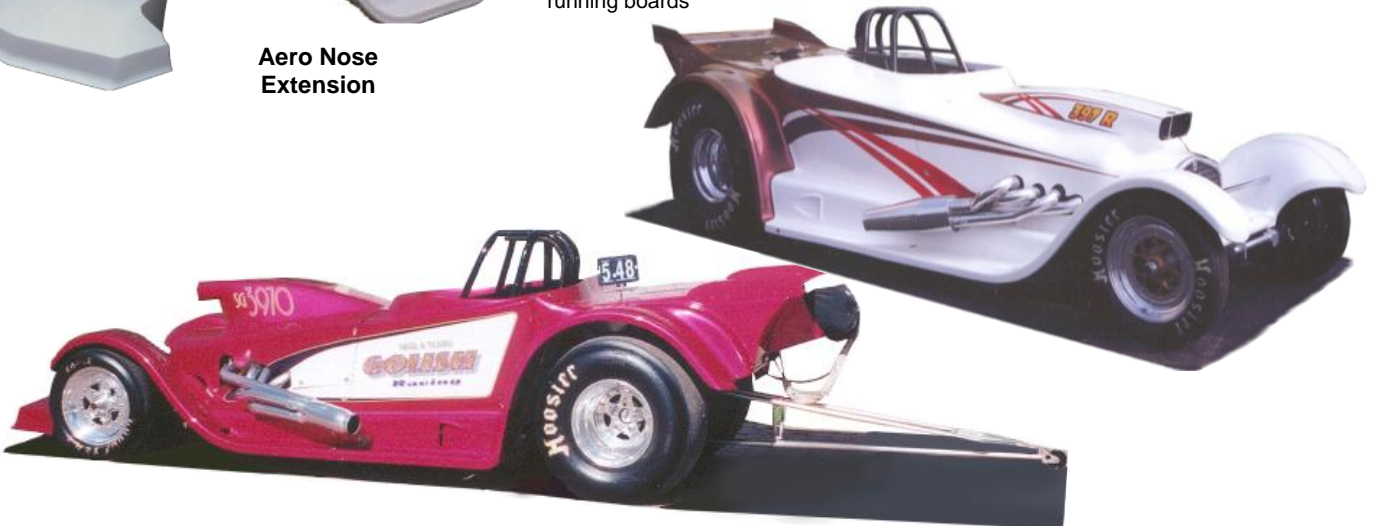

**CALL FOR INDIVIDUAL COMPONENT PRICES**



# '20 SERIES

ROADSTERS

## 20 SERIES TRADITIONAL 27's



AFC/Suncoast's 27's are available in either standard or extended cowl versions  
Add \$100.00 For Extended Cowl

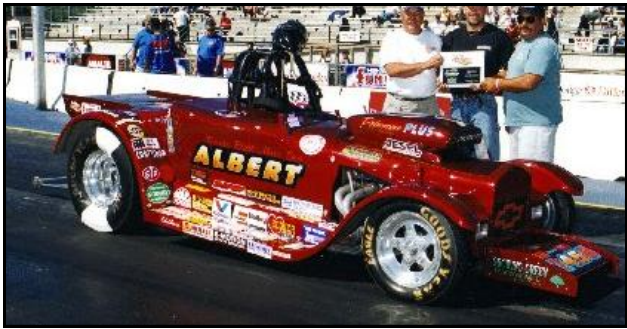
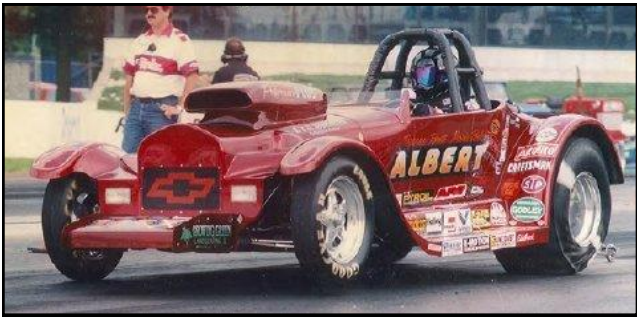

Optional Components
12" S/G Wing
16" S/G Wing
Awesome 30" Wing
Ext. Chute Pack Mt.
D/S Wind Deflector
Full 5" W/S
Pass Tonneau Cover
Aero Nose Ext.
1 Piece Nose (Strut)
1 Piece Nose (A-arm)
Driver Seat
Pass Seat
Alum. Running Boards

One piece 27 front end shown with optional AERO nose extension. (See Nose Page)  
One piece AERO nose \$449.95

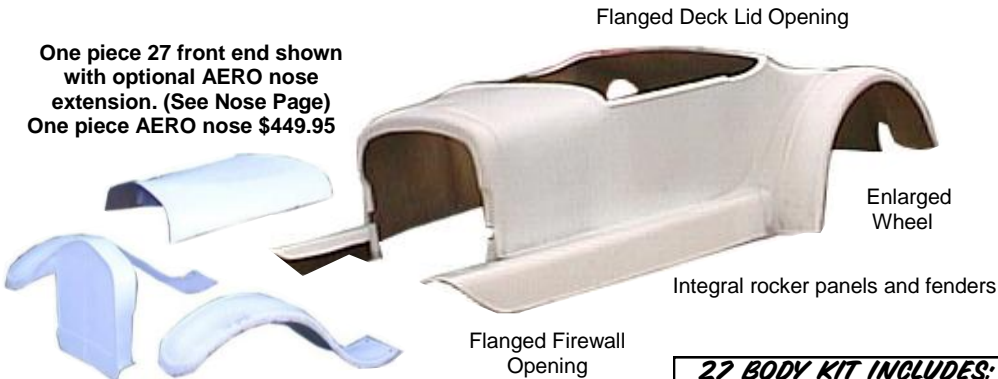

Flanged Deck Lid Opening

Enlarged Wheel

Integral rocker panels and fenders

Flanged Firewall Opening

**27 BODY KIT INCLUDES:**  
Rear body clip 2 front fenders, grill shell and hood with removable deck lid.  
-Call or see price sheet-

CALL FOR INDIVIDUAL COMPONENT PRICES

# '30 SERIES

## 30 SERIES ROADSTERS

The '30 Series Roadster came about, because of the need of better aerodynamics & driver room than the '27's had. So in the mid '90's AFC/Suncoast set about to design this new body style the first legal NHRA/IHRA and A/SR built with this body for Norm Lariccia, immediately set both the ET and speed records (which was previously held by Lariccia's AFC/Suncoast 27) and AFC/Suncoast bodies still continue to hold the records in both A&B/SR and have won many divisional and national events.

### '34 CHEVY'S, '33 FORD'S, & '33 DODGE'S



**Arnie Martel**  
NHRA Comp Eliminator B/SR Many time Winner & Record Holder



**Vinny Barone & Anthony Bertozzi**  
NHRA Comp Eliminator A/SR Many time Winner & Record Holder



**Russell Joly**  
Ft. Worth, TX



**Mike & Carlos Lawrence B/SR**  
Cincinnati Ohio

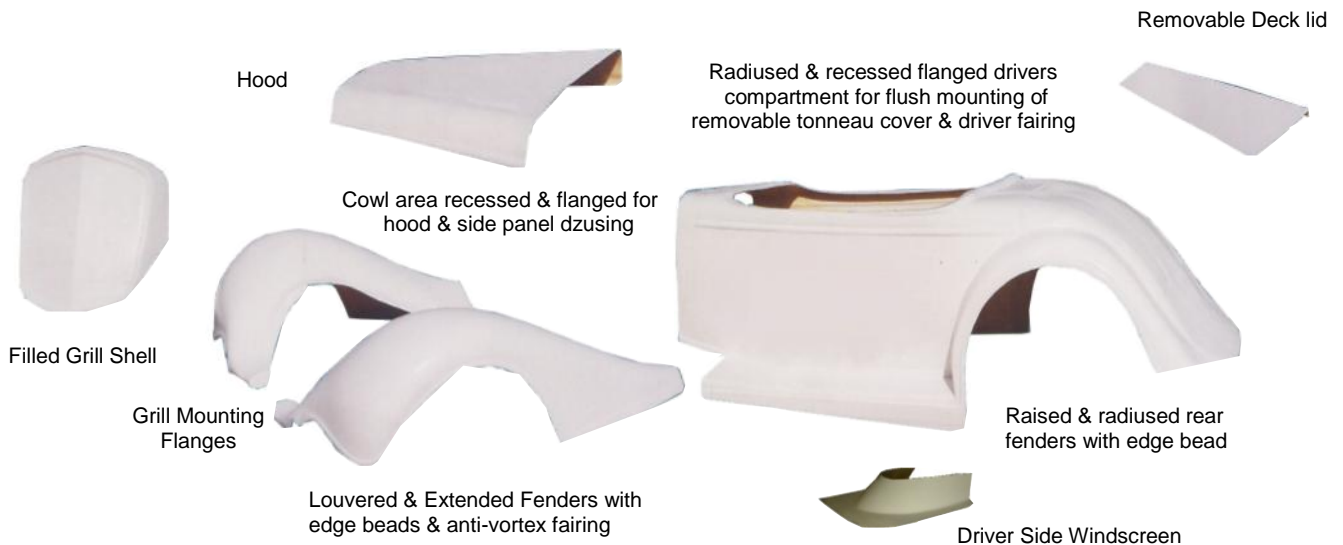

**'30 SERIES BODY KIT INCLUDES:**  
Main body clip w/ recessed decklid dzusing flange, removable decklid, grill shell, hood, 2 front fenders, flat hood sides (pair)  
**-CALL OR SEE PRICE SHEET-**



# '30 SERIES

## 30 SERIES ROADSTERS

The late model ('36 Dodge, '37 Ford & '38 Chevy) are by far the most aerodynamic of the pre '50's roadsters. These cars have more radiused fenders than early '30's series roadsters as well as integral front bumpers that allow low front end heights to keep air out from under the car, and also more laid back and pointed grilles. These bodies contain all of the standard AFC features and benefits, such as fully flanged driver compartments for easy removal of tonneau cover and deck lid.

### '38 CHEVY'S, '37 FORD'S & '36 DODGE'S



Florida's Own Ed Revis  
Best Appearance & Best Engineered



"Driver Extraordinaire"  
Corky Markwart  
Many Time National & Divisional winner



Steven Shaughnessy's  
'37 Ford Roadster

R  
O  
A  
D  
S  
T  
E  
R  
S

OPTIONAL COMPONENTS	
<u>'34-'38 Chevys, '33-'37 Fords</u>	
<u>'33-'36 Dodges</u>	
Driver Side	
Windscreen Fairing	
Pass Tonneau Cover	
Fiberglass Dash	
12" S/g Wing	
16" S/g Wing	
14" Adjustable Comp Wing	
Tubular Chute	
Pack Mount Ext.	
Awesome 30" Top Sportsmen Wing	
Ext. Chute Pack Mount	
Composite Driver Seat Fits Chassis Contours For Most Room	1 pc.
	2 pc.
Passenger Seat	1 pc.
	2 pc.
Front Bumper	
Front Fender Louvered Sections	(Pair)
Rear Fender Louvered Sections	(Pair)
Rear Body Louvers	
Tail & Head Light Packages	

'38 Chevy Nose



Radiused & recessed flanged drivers compartment for flush mounting of removable tonneau cover & driver fairing

Removable Deck lid



Raised Rear Pan



'37 Ford Nose With Headlight Provisions



Cowl area recessed & flanged for hood & side panel dzusing

Integral extended running boards/splash aprons



Raised & radiused rear fenders with edge bead

Integral Front Bumper Spoiler

Driver Side Windscreen

**'37 - '38 SERIES BODY KIT INCLUDES:**  
Main body clip w/ recessed decklid, tonneau & windshield flanges, 1 piece front end, removable decklid & hood  
**-CALL OR SEE PRICE SHEET-**

# '53-'57 "VETTE" ROADSTERS

## '53-'55 "VETTE"

The '53-'55 "Vette" Roadster body from AFC comes with all the standard features and benefits you have come to expect from an AFC body, such as anti vortex fairing on the wheel wells, enlarged rear wheel openings, 360° flanges for the tonneau covers and truck lid, integral wing flange and wheelie bar tunnel, ect.



OPTIONAL COMPONENTS '53-'55 Vette Roadster, '56-'57 Vette Roadster
Pass Tonneau Cover
Drivers Windscreen
Replica Dash
2 pc. Composite Seat Fits Chassis Contours For Maximum Room
Passenger Seat
14" Fixed Wing
14" Pro Adjustable Wing
Ext. Chute Pack Mt.
6" Cowl Hood:
53-'55 2 pc. Bumper (Frt)
2 pc. Rear bumper
Grill Teeth
Head Light Package
Tail Light Package

**-CALL OR SEE PRICE SHEET-**

## '56-'57 "VETTE"



AFC/Suncoast designed these bodies around true classics, the '57-'58 Corvette's. These bodies except "OEM" style tail lights and headlights, trim, grill trim, and etc. So if your into chrome this is the body for you. The mid '50's "Vette" bodies have all the feature and benefits that you have come to expect from an AFC body such as recessed and flanged firewall, drivers compartment, hood, deck lid, integral wheelie bar tunnel, and etc. As well as an integral wing mounting flange and ground effects style rockers.



**'56-'57 "VETTE" ROADSTER BODY KITS INCLUDE :**  
 Rear clip w/ removable decklid & front end with removable hood  
 (FOR TONNEAU COVERS SEE ABOVE FOR OPTIONS)  
**COMPOSITE AVAILABLE**  
**-CALL OR SEE PRICE SHEET-**





# '58-'62 "VETTE" ROADSTERS

ROADSTERS

## '58-'60 "VETTE"

The AFC '58-'60 "Vette" bodies feature integral headlights & rings as well as the front bumper and ground effects style front spoiler, and have all standard features you have come to expect with an AFC Body such as anti vortex fairing on the wheel wells, enlarged rear wheel openings, 360° flanges for tonneau covers and trunk lid, integral wing flange and wheelie

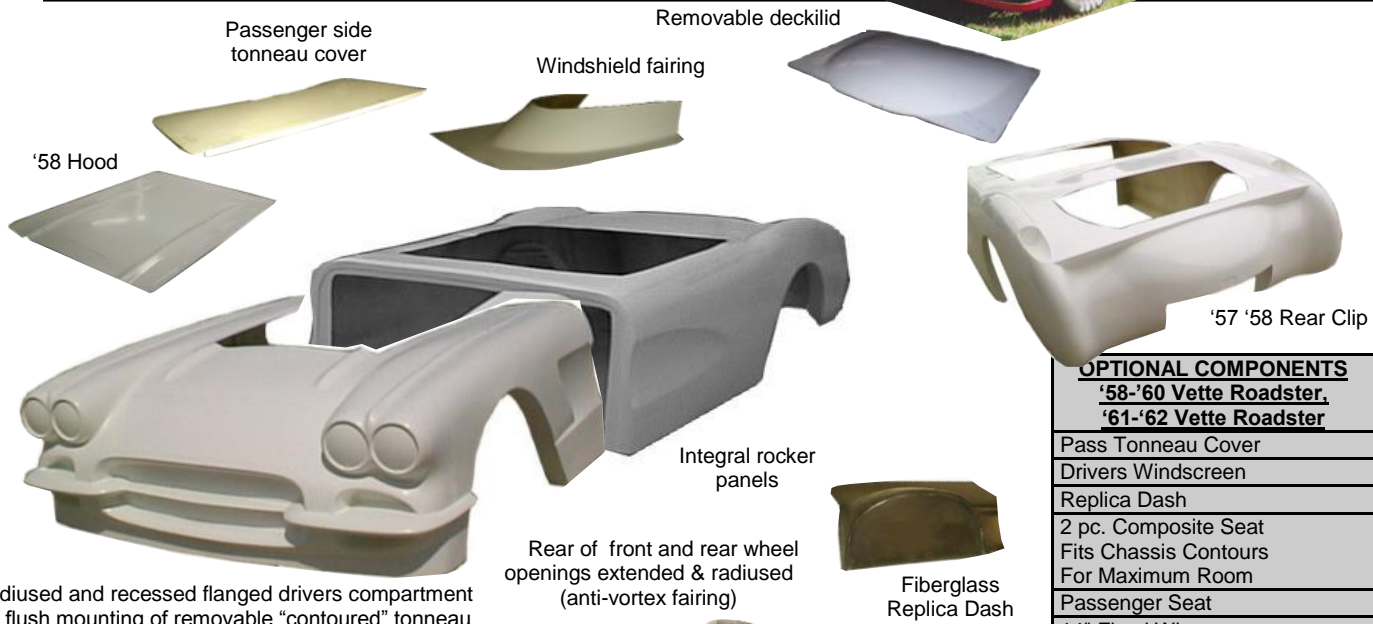

Radiused and recessed flanged drivers compartment for flush mounting of removable "contoured" tonneau cover and drivers windshield fairing

Rear of front and rear wheel openings extended & radiused (anti-vortex fairing)

OPTIONAL COMPONENTS	
'58-'60 Vette Roadster	'61-'62 Vette Roadster
Pass Tonneau Cover	
Drivers Windscreen	
Replica Dash	
2 pc. Composite Seat Fits Chassis Contours For Maximum Room	
Passenger Seat	
14" Fixed Wing	
14" Pro Adjustable Wing	
Ext. Chute Pack Mt.	
6" Cowl Hood:	
57 2 pc. Bumper (Frt)	
58 1 pc. Bumper (Frt.)	
2 pc. Rear bumper	
58 Grill Teeth	
Head Light Package	
Tail Light Package	

**'58"VETTE" ROADSTER BODY KITS INCLUDE :**  
 Rear clip w/ removable decklid & front end with removable hood  
 (FOR TONNEAU COVERS SEE OPTIONS)  
 (CALL FOR PRICE ON AERO)  
**COMPOSITE AVAILABLE**  
**-CALL OR SEE PRICE LIST-**

'58 "Vette" Roadster with "OEM" style front end



## '61-'62 "VETTE"

The AFC '61-'62 "Vette" bodies feature integral headlights & rings as well as the front bumper and ground effects style front spoiler, and have all standard features you have come to expect with an AFC Body such as anti vortex fairing on the wheel wells, enlarged rear wheel openings, 360° flanges for tonneau covers and trunk lid, integral wing flange and wheelie bar tunnel, etc.

As well as the definitive body line around the rear body section and recesses for "OEM" style taillights.



**'62 "VETTE" ROADSTER BODY KITS INCLUDE :**  
 Rear clip w/ removable decklid & front end with removable hood  
 (FOR TONNEAU COVERS SEE OPTIONS)  
 (CALL FOR PRICE ON AERO)  
**COMPOSITE AVAILABLE**  
**-CALL OR SEE PRICE LIST-**

# '63-'67 "VETTE" ROADSTERS

'63-'67 "VETTE" STD.

STANDARD, NARROWED & AERO STYLES

Another AFC "Home Run" is the very aerodynamic '63-'67 "Vette" Roadster. This body is much more aerodynamic than the '27's or even the '30 series Roadsters. This "classic" "Vette" body is easily fitted to many existing roadster chassis providing you the racer with an easy way to update your current combination. This great body style has been modified to eliminate all the disadvantages that a "OEM" style "Vette" body has in the past presented to the builder and still retains its classic lines and looks.

These design modifications consist of moving the rear wheel opening C/L back 2", allowing "Pro" 4-link dimensions, which also allows the driver to sit in the correct position with plenty of leg room. The tops of the quarters are raised and recontoured for maximum clearance for even the biggest tires, yet still retains a low overall height of the finished car.



*Ed Richard & Steve Cohen in NHRA Atlanta National Finals*

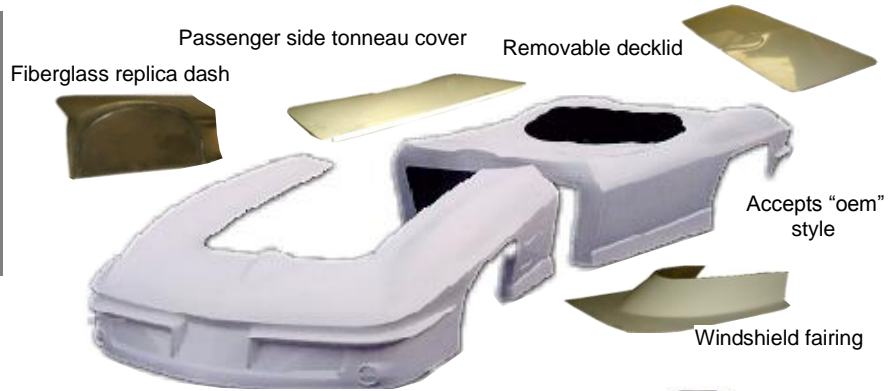

'67 COMP STYLE "SHORT" NOSE WITH VERTICAL VENTS... AN AFC EXCLUSIVE!!!

63 S/G-Pro Mod style "Long" nose with horizontal vents and parking lights

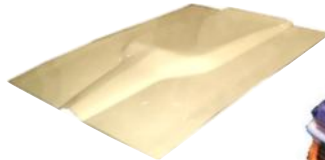

Four styles of hoods available S/G -"Pro Mod 396" style pictured

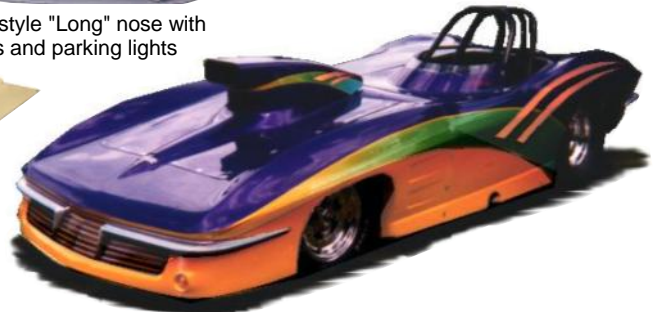

**'63-'67 "VETTE" ROADSTER BODY KITS INCLUDE :**  
Rear clip w/ removable decklid & front end with removable hood  
( FOR TONNEAU COVERS SEE OPTIONS )  
**-CALL OR SEE PRICE SHEET -**

'63-'67 "VETTE"



*Maryland's Wade McAffey Corvette has turned his '27 Ford Roadster into this award winning , sleek, aerodynamic "Vette". How do you get \$30-\$40,000 for your '27 Ford Roadster ..... You put a late model body on it .... That's How !!!*

*This aero "Vette" body was mounted on a 118" WB '27 chassis. The highly experienced personnel at Suncoast Race Cars can assist you with everything you may need for your body conversion .*



**'63-'67 "VETTE" ROADSTER BODY KITS INCLUDE :**  
Rear clip w/ removable decklid & front end with removable hood  
( FOR TONNEAU COVERS SEE OPTIONS )  
**-CALL OR SEE PRICE SHEET- (COMPOSITE AVAILABLE)**

**OPTIONAL COMPONENTS**  
**'63-'67 "Vette" Roadster**

Windscreen Fairing
Pass Tonneau Cover
Replica Dash
2 pc. Composite Seat Fits Chassis Contours For Maximum Room
Passenger Seat
14" Fixed Wing
14" Pro Adjustable Wing
Ext. Chute Pack Mt.
6" Cowl Hood:
Tail Light Package
Head Light Package
2pc Rear bumper ('63-'67)



# 2K – '08 "VETTE" ROADSTERS

## 2K "VETTE" STD & AERO STYLES

The 2K "Vette" Roadster is AFC/Suncoast S/G-S/C version of the most aerodynamic production body ever produced, a sleek reduced nose with straight sides to give you the utmost in aerodynamics. This body has all the features and benefits you have come to expect from an AFC body, such as, recessed and flanged firewall for easy installation, hood, integral wheelie bar, drivers compartment, deck lid, and etc. It also features down sized front wheel openings and enlarged rear wheel opening with raised quarters, and integral ground effects style rocker panels.

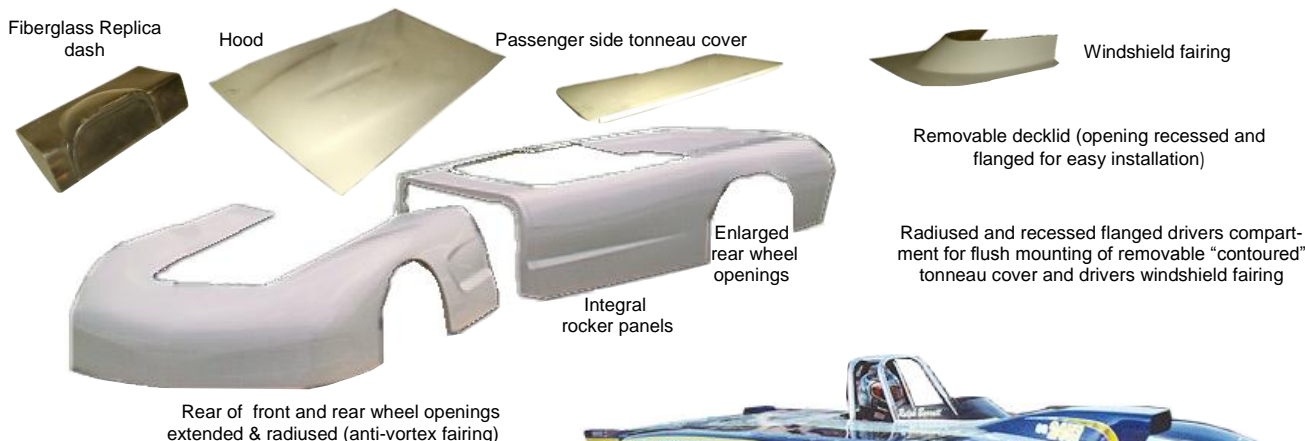

**2K "VETTE" ROADSTER BODY KIT INCLUDES:**  
 Rear clip with removable decklid & front end with removable hood  
 (FOR TONNEAU COVERS SEE OPTIONS)  
**-CALL OR SEE PRICE SHEET-  
 COMPOSITE AVAILABLE**



## '05-'07 "VETTE" STD & AERO STYLES

The '05-'08 "Vette" Roadster has the best of everything, superior looks and aerodynamics, removable decklid, tonneau cover and drivers side windshield fairing as well as its down sized front wheel openings, enlarged rear wheel openings and integral ground effects rockers.

The overall dimensions have been down sized to almost the same as our immensely popular '63 "Vette" Roadster. The new "Vette" lines really lend themselves to the "raised quarter treatment" and look like it should have been that way! The front end has maximum over hang and integral hood, all of this coupled with the integral wheelie bar tunnel, "anti vortex" fairing on the wheel openings, classic looks combined with all of the features and benefits you have come to expect from an AFC body.

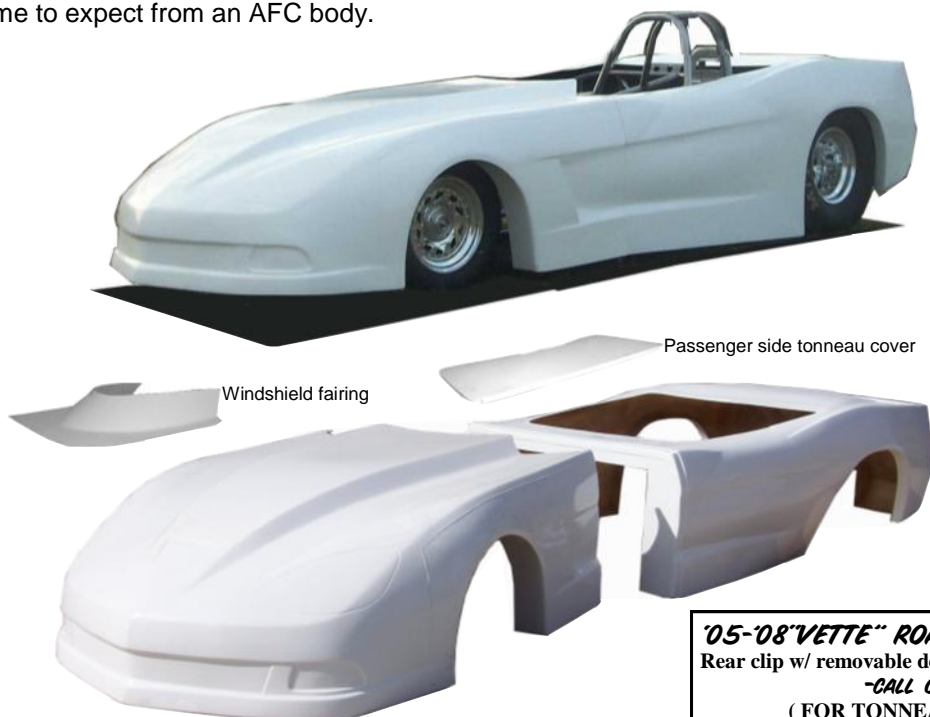

<b>OPTIONAL COMPONENTS 2K &amp; '08 "Vette" Roadsters</b>
Windscreen Fairing
Pass Tonneau Cover
Replica Dash
2 pc. Composite Seat Fits Chassis Contours For Maximum Room
Passenger Seat
14" Fixed Wing
14" Pro Adjustable Wing
Ext. Chute Pack Mt.
6" Cowl Hood:
Tail Light Package

**'05-'08 "VETTE" ROADSTER BODY KITS INCLUDE :**  
 Rear clip w/ removable decklid & front end with removable hood  
**-CALL OR SEE PRICE SHEET-**  
 (FOR TONNEAU COVERS SEE OPTIONS)  
 (CALL FOR PRICE ON AERO)  
**COMPOSITE AVAILABLE -CALL-**

**CALL FOR BODY DIMENSIONS SHEETS**

# '57 CHEVY & '68 - '69 CAMARO

## '57 CHEVY

The AFC '57 Chevy Roadster is a "Topless" version of our popular "Top Sportsman" '57 Chevy that has been tastefully modified to be more aerodynamic and incorporate features such as raised quarters and enlarged rear wheel openings to allow "Big Tires" which gives a slight wedge shape from front to rear. Plus the body has been narrowed to approximately the same dimensions as a '63 "Vette" Roadster and it has all the standard features and benefits that you have come to expect on and AFC Roadster body such as flanges recessed for easier assembly of firewall, windshield fairing and tonneau cover, hood and decklid is as well as integral ground effects rockers and wheelie bar tunnel.

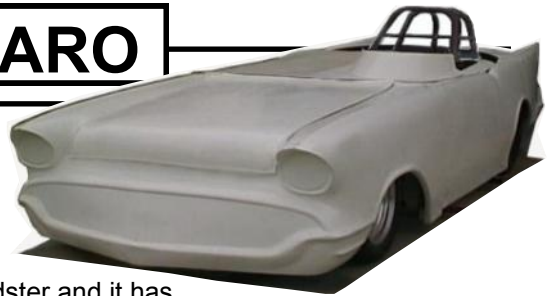

OPTIONAL COMPONENTS '57 Chevy & Camaro
Windscreen Fairing
Pass Tonneau Cover
Replica Dash
2 pc. Composite Seat Fits Chassis Contours For Maximum Room
Passenger Seat
14" Fixed Wing
14" Pro Adjustable Wing
Ext. Chute Pack Mt.
6" Cowl Hood:
Tail Light Package
Head Light Package
'57 Grill Bar

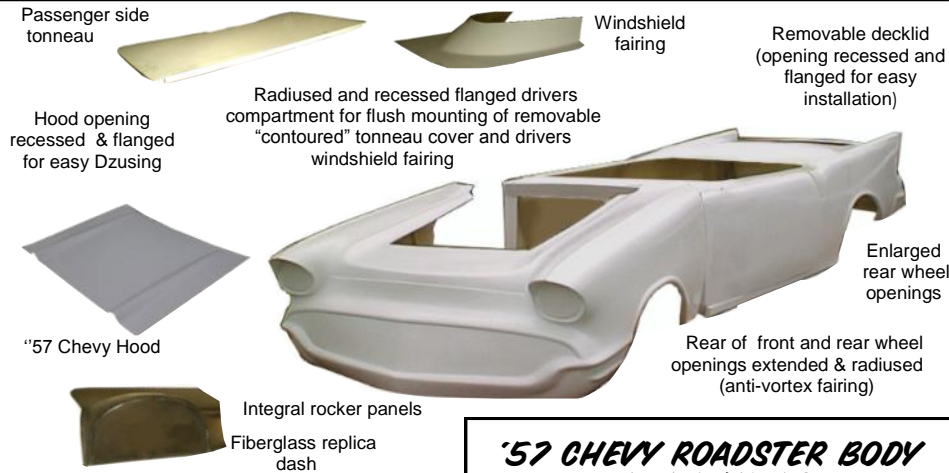

### '57 CHEVY ROADSTER BODY KIT INCLUDES:

Rear clip, removable decklid, front end, & removable hood  
-CALL OR SEE PRICE SHEET-

## '68 CAMARO

The '68-'69 Camaro Roadsters are the latest in AFC / Suncoasts line of "Classic" Roadster bodies. It has all the features and benefits you have come to expect from and AFC / Suncoast body such as enlarged rear wheel openings ( the front wheel openings have been downsized for 25" tires) The tops of the quarters are raised and recontoured to give the maximum clearance for even the biggest tires, yet still retains a low overall height of the finished car. Even with these modifications it still retains the classic looks of a '68-'69 Camaro only a purist could tell the difference! These features combined with the Suncoast / AFC "builder friendly" design and smooth glossy Exterior finish as up to give you the nicest, highest quality race car body Available anywhere, at any price!!! The '68-'69 Camaro can be built from 108" wheelbase to 115" wheel base allowing the builder to trim back the nose for their specific chassis and needs.

Redding, CA's  
Craig Blaisdell's  
'68 Camaro  
Roadster

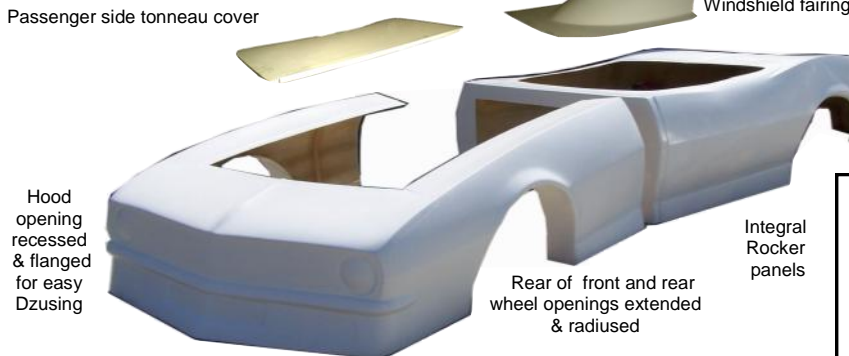

### '68 CAMARO ROADSTER BODY KIT INCLUDES:

Rear clip, removable decklid, front end, & removable hood  
-CALL OR SEE PRICE SHEET-

## '69 CAMARO

**CALL FOR INFORMATION ON '69 CAMARO ROADSTER BODIES**

### '69 CAMARO ROADSTER BODY KIT INCLUDES:

Rear clip, removable decklid, front end, & removable hood  
-CALL OR SEE PRICE SHEET-  
COMPOSITE AVAILABLE

**PICTURES WERE NOT AVAILABLE AT PRESS TIME**



# 2K "CAVALIER" & 2K "VIPER"

## 2K CAVALIER

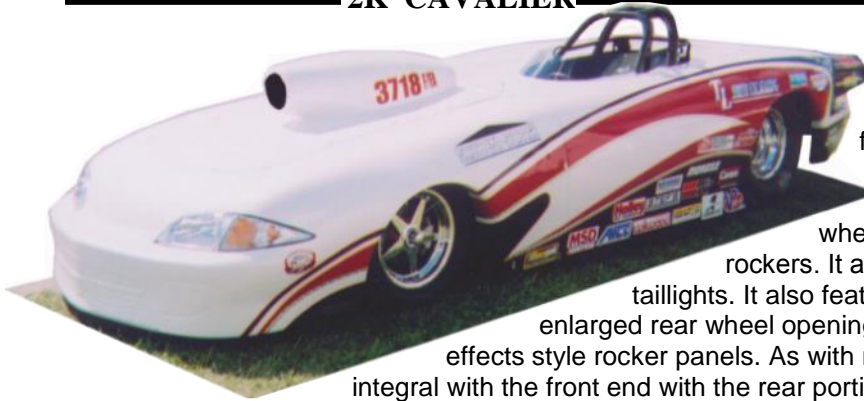

AFC/Suncoast designed the Cavalier roadster around the hottest body style in Pro Stock, the 2K Cavalier. The AFC Cavalier has all the features you have come to expect from an AFC body, such as recessed and flanged firewall, drivers compartment, hood, deck lid, integral wheelie bar tunnel and ground effects style rockers. It also accepts "OEM" style head lights and taillights. It also features down sized front wheel openings and enlarged rear wheel opening with raised quarters, and integral ground effects style rocker panels. As with most AFC Bodies the front third of the hood is integral with the front end with the rear portion removable.

**\*\*See Options\*\***

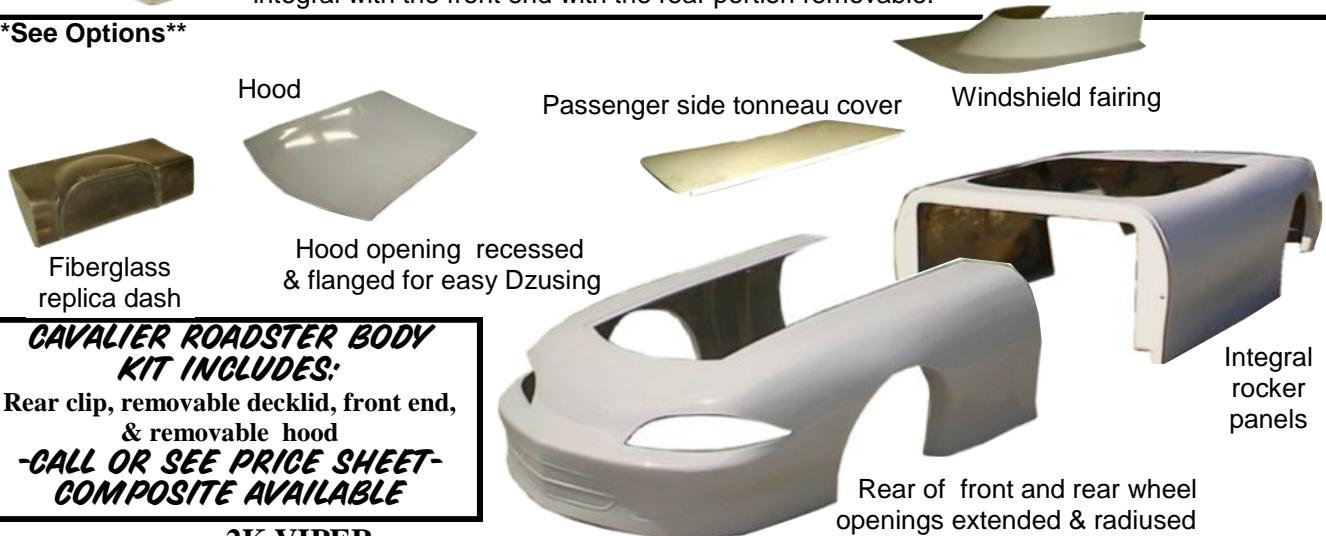

**CAVALIER ROADSTER BODY KIT INCLUDES:**  
 Rear clip, removable decklid, front end, & removable hood  
**-CALL OR SEE PRICE SHEET-  
 COMPOSITE AVAILABLE**

## 2K VIPER

AFC/Suncoast designed this body for the Mopar guys, to them a swoopy late model body with the same features and benefits the GM and Ford guys have access to, such as recessed and flanged cowl area for easy installation of the fire wall, flanged drivers compartment for easy installation of driver side wind screen fairing and passenger side tonneau cover and it also features flanges for hood and deck lid installation as well as integral wheelie bar tunnel and ground effect style rockers.

### OPTIONAL COMPONENTS 2K CAVALIER & 2K Viper

Windscreen Fairing
Pass Tonneau Cover
Replica Dash
2 pc. Composite Seat Fits Chassis Contours For Maximum Room
Passenger Seat
14" Fixed Wing
14" Pro Adjustable Wing
Ext. Chute Pack Mt.
Headlight Package
Tail Light Package



**2K VIPER ROADSTER BODY KIT INCLUDES:**  
 Rear clip w/ removable decklid & front end with removable hood<sup>s</sup>  
**-CALL OR SEE PRICE SHEET-**

**CALL FOR BODY DIMENSIONS SHEETS**



ROADSTERS

# 55-57 T-BIRD & COBRA

## 55-57 T-BIRD

Another AFC exclusive is the all new '57 T-Bird. It has all the features and benefits that you have come to expect from an AFC body, such as recessed and flanged cowl area for easy installation of the fire wall, drivers compartment, hood, and deck lid.

AFC/Suncoast designed this body to accept "OEM" style head lights and tail lights as well as an integral wheelie bar tunnel, ground effects style rockers, and an integral wing mounting flange.

*SO IF YOUR LOOKING FOR A*



OPTIONAL COMPONENTS '55-'57 T-Bird
Windscreen Fairing
Pass Tonneau Cover
Replica Dash
2 pc. Composite Seat
Fits Chassis Contours
For Maximum Room
Passenger Seat
14" Fixed Wing
14" Pro Adjustable Wing
Ext. Chute Pack Mt.
Headlight Package
Tail Light Package

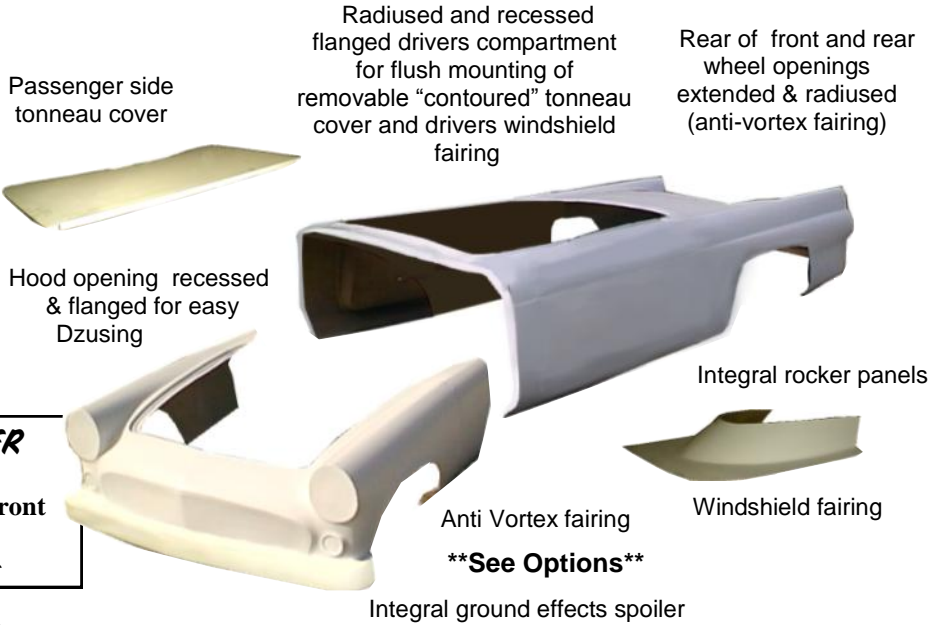

Passenger side tonneau cover

Radiused and recessed flanged drivers compartment for flush mounting of removable "contoured" tonneau cover and drivers windshield fairing

Rear of front and rear wheel openings extended & radiused (anti-vortex fairing)

Hood opening recessed & flanged for easy Dzusing

Integral rocker panels

**'55-'57 T-BIRD ROADSTER BODY KIT INCLUDES:**  
 Rear clip w/ removable decklid & front end with removable hood  
**-CALL OR SEE PRICE SHEET-**

Anti Vortex fairing

Windshield fairing

**\*\*See Options\*\***

Integral ground effects spoiler

## COBRA

The AFC Cobra Body is available in either a race style roadster or a street style with functioning doors, removable decklid, and hood. The race version is set up for 104"-112" wheel base with all the benefits and features you have come to expect from an AFC/Suncoast body such as removable tonneau covers, windshield fairing, decklid, front end and hood as well as integral ground effects style rocker panels.

The street version is based on the original 90" wheel base and features more laminates for a long lasting body with street use, it accepts original style headlights and taillights as well as being available in longer wheel bases and have the option of fiberglass floor pans, trunk floor & transmission tunnel compo-

AVAILABLE COBRA VERSIONS & OPTIONAL COMPONENTS
RACE VERSION (longer wheel bases available)
DOORSLAMMER VERSION (STRETCHED, RACE WEIGHT)
DOORSLAMMER VERSION (STRETCHED, STREET WEIGHT)
FLOOR PAN AND TRANSMISSION TUNNEL COMPONENT KIT
ROOF



FLOOR PAN WITH TRANSMISSION TUNNEL & INTEGRAL FIRE-WALL

HOOD

ROOF

FIREWALL

DOORS



# '2K- '08 MUSTANG

## 2K MUSTANG

AFC/Suncoast designed this body to give Ford guys a body as nice as the Chevy guys have access to. It has all the features and benefits that you have come to expect from an AFC body, such as recessed and flanged cowl area for easy installation of the firewall, fully recessed and flanged drivers compartment, hood, deck lid, the front portion of the hood is integral to the front end, with the remaining body removable. It also accepts "OEM" style headlights and tail lights as well as integral ground effects style rockers, and wheelie bar tunnel.

Front ends available with headlights filled for airbrushing



Hood



Hood opening flanged for easy hood dzusing



Windshield Fairing



Passenger side tonneau cover

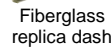

Fiberglass replica dash



'04 & '05 Front ends also available with openings & flanges to fit "OEM" style headlights ...ADD \$100.00

Anti Vortex fairing

Integral ground effects style rocker panels

OPTIONAL COMPONENTS 2K Mustang
Windscreen Fairing
Pass Tonneau Cover
Replica Dash
2 pc. Composite Seat Fits Chassis Contours For Maximum Room
Passenger Seat
14" Fixed Wing
14" Pro Adjustable Wing
Ext. Chute Pack Mt.
Headlight Package
Tail Light Package

**2K MUSTANG ROADSTER BODY KIT INCLUDES:**  
Rear clip w/ removable decklid & front end with removable hood  
**-CALL OR SEE PRICE SHEET-**

## '05-'08 MUSTANG

Once again AFC have provided the Ford Guys with a body that has all the features and benefits of an AFC / Suncoast body such as recessed and flanged cowl area for easy installation of the firewall, fully recessed and flanged drivers compartment, hood, decklid, the front portion of the hood is integral to the front end, with the remaining body removable. It also accepts "OEM" style headlights and taillights as well as integral ground effects style rockers and wheelie bar tunnel.



Painted front end



Windshield Fairing



Hood



Passenger side tonneau cover



**'05-'08 MUSTANG ROADSTER BODY KIT INCLUDES:**  
Rear clip w/ removable decklid & front end with removable hood  
**-CALL OR SEE PRICE SHEET-**

ROADSTERS

**ORDERS:**

A 50% deposit is required on all orders. The balance must be paid before parts are shipped. *Please note that personal or business checks will take 10 business days from the date they are deposited to clear our bank before the order can be shipped.*

**PRICES & SPECIFICATIONS:**

All prices and specifications are subject to change without notice.

**SHIPPING AND FREIGHT:**

All components will be shipped freight collect unless prior arrangements have been made.

**RETURN POLICY:**

No returns will be accepted without authorization from Suncoast Performance, Inc. d/b/a Suncoast Race Cars. Custom built or special order items are not returnable. Return freight charges must be prepaid on any returns and a copy of the original invoice enclosed with return. A minimum of 15% restocking fee will apply to all returns (some items will be higher). Unauthorized items, items sent C.O.D. or items that have been modified or damaged in any way will not be accepted.

**WHEN YOU RECEIVE YOUR ORDER:**

**1. CHECK FOR DAMAGE**

As soon as you receive your order you need to inspect it carefully in case it was damaged in shipping. If anything was damaged you need to notify the carrier (UPS, Fed-X, etc.) immediately (trucking companies require that you notify the driver at the time of delivery – make sure the driver notes any damage on the bill of lading). The carrier will return the part to us for replacement. Note: the carrier will request that you save the original box and packaging materials for their examination before a claim can be made.

**2. CHECK TO MAKE SURE THE PARTS & QUANTITIES ARE CORRECT**

Verify you have received what you had on order. If there are any discrepancies you must notify us immediately upon receipt of the order. Do not use or modify parts in any way before verifying that they are correct. You will not be able to return them if they have been installed or modified.

**WARRANTIES :**

Use of this product is acceptance of seller's disclaimer of warranty.

The purchaser is responsible for determining the suitability and acceptability of any and all products purchased from Suncoast Performance, Inc. d/b/a Suncoast Race Cars.

There is no warranty stated of implied due to the unusual stresses placed on race cars and their components, and the fact that we have no control over how the parts are used, installed and /or maintained. Due to the fact that the very nature of the sport of auto racing is and can be hazardous to one's health and participation in this sport may result in serious injury or death, Suncoast Performance, Inc. d/b/a Suncoast Race Cars neither accepts nor assumes any liability for failures of racing components manufactured and / or sold by Suncoast Performance, Inc. d/b/a Suncoast Race Cars, therefore the customer accepts all responsibility and / or liability resulting from the use of products purchased.

**NOTE:**

Please note that chassis kits and many of their related components are in raw material form, they are not polished, plated, powder coated, painted , etc. for a reason. This is necessary due to the construction processes that they still have to go through (welding, grinding, etc.). All exterior finishing of components should be done after final welding is completed.

**PURCHASE:**

Purchase of our products is customers acceptance of our sales terms. Terms of sale include but are not limited to the customer guaranteeing not to reproduce our products in any form or manner, nor allowing them to be reproduced by any of their employees, representatives or anyone else associated with them (i.e. chassis builders, fiberglass companies, etc.). Customer will be responsible for all cost of litigation resulting from their failure to uphold these terms.

**VISIT US AT [www.suncoastracecars.com](http://www.suncoastracecars.com) OR CALL (352)-628-5001**



Visit Our Web Site  
@www.suncoastracecars.com

**RICHARD EARLE'S**  
**SUNCOAST**  
**RACE CARS**  
QUALITY RACE CARS AND COMPONENTS SINCE 1976  
6240 S. TEX POINT HOMOSASSA, FL 34448 PHONE: 352-628-5001



THE ORIGINAL "HARD-CORE" CHASSIS SHOP  
Where one call does it all!!!

Pick up your phone and find today's answer to your neighborhood speed and chassis shop, a place where you can establish a "solid" working relationship, ask questions or advice and get an honest answer from experienced racers who know your needs

**STEP UP TO SUNCOAST, WHERE ONE CALL DOES IT ALL !!** **QUALITY, SERVICE & SATISFACTION**

**ORDER LINE: 352-628-5001**

**AND**

**24 HOUR FAX: 352-628-5300**



RICHARD EARLE'S SUNCOAST RACE CARS  
QUALITY RACE CARS AND COMPONENTS SINCE 1976