



Service Manual

FOR THE TURBOCHEF TORNADO[®] AND TORNADO 2[™]
RAPID COOK OVENS



For further information call:

800.90TURBO

+1 214.379.6000



Accelerating the World of Cooking™

IMPORTANT SAFETY INFORMATION - PLEASE READ FIRST

 **WARNING:** Improper installation, adjustment, alteration, service, or maintenance can cause property damage, injury, or death. Thoroughly read the installation, operating, and maintenance instructions before installing or servicing this equipment.

This product employs an exposed radiant heating element in the bottom of the cavity. This element is HOT during operation and will remain at dangerous temperatures after the unit is switched off. NEVER attempt to touch the element during operation, while the oven is warm, or while the oven is cooling down.

☒ DO NOT store flammable vapors or liquids (such as gasoline) in the vicinity of this or any other appliance.

The information contained in this manual is important for the proper installation, use, and maintenance of this oven. Adherence to these procedures and instructions will result in satisfactory baking results and help prevent maintenance. Please read this manual carefully and retain it for future reference.

Errors - descriptive, typographic, or pictorial - are subject to correction. Specifications are subject to change without notice.

Table of Contents

| | |
|---|-----|
| Important Safety Instructions | i |
| General Safety Information | i |
| Reducing Fire Risk | i |
| Precautions to be Observed Before and During Servicing to Avoid Possible Exposure to Excessive Microwave Energy | ii |
| Grounding Instructions | ii |
| Power Cord Replacement | ii |
| RF Interference Considerations | ii |
| Chapter 1: Installation, Specifications and Maintenance | |
| Specs and Dimensions | 1 |
| Dimensions | 1 |
| Construction | 1 |
| Standard Features | 1 |
| Certifications | 1 |
| Packaging | 1 |
| Power Supply (Domestic and Intl Electrical Specifications) | 1-2 |
| Power Input | 2 |
| Delivery and Product Placement | 2 |
| Lifting and Placing the Oven | 2 |
| Built-In Installation | 2 |
| Installation Near Open Heat Source | 3 |
| Oven Restraint Kit | 4 |
| Ventilation Requirements | 4 |
| Setup and Initial Operation | 4 |
| Setup | 4 |
| Stacking | 4 |
| Programming | 4 |
| Initial Power-Up | 4 |
| Maintenance | 5 |
| Chapter 2: Theory of Operation | |
| Theory of Operation | 7 |
| Glossary of Common Operating Terms | 8 |
| Chapter 3: Fault Codes | |
| To View Fault Codes | 11 |
| Fault Code Definitions | 11 |
| Fault Code Table | 12 |
| Chapter 4: The Control System | |
| Control System Schematic | 13 |
| Control System Component Descriptions | 14 |
| Test Mode | 14 |
| Test Function Options | 15 |
| Status Indicators | 16 |

| | |
|--|----|
| Programming | 16 |
| Oven Options | 18 |
| User Configurable Options - Enable/Disable Codes | 19 |
| User Configurable Options - Access Codes | 19 |
| Control System Panel Parts | 20 |
| Control System Troubleshooting | 21 |

Chapter 5: The Microwave System

| | |
|---|----|
| Voltage Doubler Circuit Description | 25 |
| Monitor Circuit Description | 25 |
| Voltage Doubler Theory of Operation | 26 |
| Microwave System Parts | 26 |
| Microwave System Components | 28 |
| Wave Guide Cover Replacement | 29 |
| Wave Guide/Wave Guide Cover Parts | 30 |
| Wave Guide Replacement | 30 |
| High Voltage and Filament Transformer Replacement | 30 |
| Wiring the High Voltage Transformers | 30 |
| Wiring the Filament Transformers | 31 |
| Measuring RF Leakage for Microwave Safety | 31 |
| How to Test Microwave Components | 32 |
| Testing the High Voltage Diode | 32 |
| How to Check a Diode | 32 |
| How to Check a Capacitor | 33 |
| How to Check a Magnetron for Open/Shorted Filament | 33 |
| How to Check a High Voltage Transformer or Filament Transformer | 33 |
| High Voltage and Filament Transformer Resistance Table | 33 |
| Microwave System Troubleshooting | 34 |

Chapter 6: The Oven Door

| | |
|---|----|
| Removing/Reinstalling the Oven Door | 37 |
| Oven Door Parts | 37 |
| Adjusting the Oven Door | 38 |
| Preparing the Oven for Switch Adjustment | 38 |
| Oven Burn-In Procedure | 38 |
| Adjusting the Primary and Secondary Interlock Switches - Old Switch Setup | 38 |
| Primary and Secondary Interlock Switch Adjustments and Parts | 39 |
| Door Switch Assembly and Parts | 40 |
| Adjusting the Monitor Safety Switch - Old Switch Setup | 40 |
| Monitor Safety Switch Parts | 40 |
| Adjusting the Primary Interlock Switch - New Switch Setup | 42 |
| Primary Switch Adjustment and Parts | 42 |
| Adjusting the Secondary and Monitor Interlock Switches - New Switch Setup | 43 |
| Secondary and Monitor Safety Switch Parts | 43 |
| Oven Door Assembly | 44 |
| Oven Door Parts | 44 |
| Screw Torque Chart | 45 |
| Interlock Switch Troubleshooting | 46 |

| | |
|--|---------|
| Chapter 7: The Convection Circuit | |
| Convection Circuit Components | 47 |
| Convection Circuit/Blower Motor Parts | 48 |
| Convection Circuit Troubleshooting | 49 |
| Motor Winding Resistances Table | 50 |
| | |
| Chapter 8: IR Element and Catalytic Converter | |
| Components | 51 |
| IR Element and Catalyst Removal | 51 |
| Removing the IR Element | 51 |
| Removing & Installing the Catalytic Converter | 52 |
| Installing a New IR Element | 52 |
| IR Element and Catalytic Converter Parts | 52 |
| | |
| Chapter 9: Schematics and Schematic Components | |
| Schematic Parts | 53 |
| Line Voltage Components | 53 |
| Low Voltage Components | 53 |
| Wire Harness Replacement P/N's | 53 |
| I/O Control Board Item Identification and Test Point Locations | 53 |
| Schematic - I/O Board | 54 |
| Oven Schematics | 55 - 63 |
| | |
| Chapter 10: Service Parts and Illustrations | |
| Figure 7: NGC (Tornado) Control System | 65 |
| Figure 17: Control System Panel Enclosure and Parts | 66 |
| Figure 18: Monitor Circuit - Shown in Failsafe State | 67 |
| Figure 20: Microwave System Parts | 67 |
| Figure 21: Microwave System Parts | 68 |
| Figure 22: Wave Guide Cover/Wave Guide Removal and Replacement | 68 |
| Figure 24 & 25: High Voltage Diode and Magnetron | 69 |
| Figure 26: Oven Door Removal and Parts | 69 |
| Figure 29: Primary and Secondary Adjustment and Parts - Old Switch Setup | 70 |
| Figure 30: Door Switch Assembly and Parts | 70 |
| Figure 31: Motor Switch Adjustment and Assembly - Old Switch Setup | 71 |
| Figure 32: Primary Interlock Adjustment and Parts - New Switch Setup | 71 |
| Figure 33 & 34: Secondary and Monitor Adj. and Assy. - New Switch Setup | 72 |
| Figure 35: Oven Door Assembly | 73 |
| Figure 37: Convection Circuit Block Diagram | 74 |
| Figure 38: Convection Circuit Assembly and Parts | 75 |
| Figure 39: IR Element and Catalytic Converter Parts and Assembly | 76 |
| Figure 46: Covers and Miscellaneous Parts - Non-SBK Ovens | 77 |
| Figure 47: Covers and Miscellaneous Parts - SBK Ovens | 78 |
| | |
| Chapter 11: Comprehensive Part List | |
| Comprehensive Part List | 79 |

IMPORTANT SAFETY INSTRUCTIONS

Strictly adhere to the following safety precautions to reduce the risk of:

- Burns
- Electric shock
- Fire
- Injury
- Damage to oven or property near oven
- Exposure to excessive microwave energy

GENERAL SAFETY INFORMATION

- Read all instructions before using the appliance.
- Install or locate this appliance only in accordance with the provided installation instructions.
- Some products such as whole eggs and sealed containers (e.g., closed glass jars) may explode and should not be heated in this oven.
- Use this appliance only for its intended use as described in this manual.
- This appliance should be serviced only by qualified service personnel. Contact the nearest authorized service facility for examination, repair, or adjustment.
- Keep cord away from heated surfaces.
- ☒ DO NOT allow children to use this appliance.
- ☒ DO NOT use corrosive chemicals or vapors in this appliance - it is not designed for industrial or laboratory use.
- ☒ DO NOT operate this appliance if it has a damaged cord or plug, is not working properly, or has been damaged or dropped. See POWER CORD REPLACEMENT, page ii.
- ☒ DO NOT cover or block any openings on the appliance.
- ☒ DO NOT store this appliance outdoors.
- ☒ DO NOT use this product near water (e.g., near a kitchen sink, in a wet basement, near a swimming pool).
- ☒ DO NOT immerse cord or plug in water.
- ☒ DO NOT let cord hang over the edge of table or counter.
- ☒ DO NOT use a water jet for cleaning. See the maintenance section of this manual on page 5 for proper cleaning procedures.

REDUCING FIRE RISK

- Remove wire twist-ties from paper or plastic bags used to facilitate cooking in the oven.
- If materials inside the oven ignite,
 - Keep oven door closed
 - Turn oven off
 - Disconnect the power cord or shut off power at the fuse or circuit breaker panel
- If smoke is observed, switch off or unplug the oven. Keep the door closed to stifle any flames.
- ☒ DO NOT use the cook cavity for storage purposes.
- ☒ DO NOT overcook food. Carefully attend the oven if paper, plastic, or other combustible materials are placed inside the oven to facilitate cooking.
- ☒ DO NOT leave paper products, cooking utensils, or food in the cavity when not in use.

SAVE THESE INSTRUCTIONS

PRECAUTIONS TO BE OBSERVED BEFORE AND DURING SERVICING TO AVOID POSSIBLE EXPOSURE TO EXCESSIVE MICROWAVE ENERGY

- (a) DO NOT operate or allow the oven to be operated with the door open.
- (b) Make the following safety checks on all ovens to be serviced before activating the magnetron or other microwave source, and make repairs as necessary: (1) interlock operation, (2) proper door closing, (3) seal and sealing surfaces (arcing, wear, and other damage), (4) damage to or loosening of hinges and latches, (5) evidence of dropping or abuse.
- (c) Before turning on microwave power for any service test or inspection within the microwave generating compartments, check the magnetron, wave guide or transmission line, and cavity for proper alignment, integrity, and connections.
- (d) Any defective or misadjusted components in the interlock, monitor, door seal, and microwave generation and transmission systems shall be repaired, replaced, or adjusted by procedures described in this manual before the oven is released to the owner.
- (e) A microwave leakage check to verify compliance with the Federal performance standard should be performed on each oven prior to release to the owner.

GROUNDING INSTRUCTIONS

This appliance must be grounded. In the event of an electrical short circuit, grounding reduces the risk of electric shock by providing an escape wire for the electric current. This oven is equipped with a cord that has a grounding wire with a grounding plug, which must be plugged into an outlet that is properly installed and grounded. Consult a qualified electrician or serviceman if uncertain about the ability to follow grounding instructions or if doubt exists as to whether the appliance is properly grounded.

- ❑ DO NOT use an extension cord. If the power cord is too short, have a qualified electrician or serviceman install an outlet near the appliance.



WARNING: Improper grounding can result in risk of electric shock.

POWER CORD REPLACEMENT

If the power cord is damaged, it must be replaced by the manufacturer, its service agent, or a similarly qualified person.

RF INTERFERENCE CONSIDERATIONS

The NGC (Tornado[®]) oven generates radio frequency signals. This device has been tested and was determined to be in compliance with applicable portions of FCC part 18 requirements and to the protection requirements of Council Directive 89/336/EEC on the approximation of the laws of the Member States relating to electromagnetic compatibility at the time of manufacture. However, some equipment with sensitivity to signals below these limits may experience interference.

If your equipment experiences interference:

- ❑ Increase the physical separation between this oven and the sensitive equipment.
- ❑ If the sensitive device can be grounded, do so following accepted grounding practices.
- ❑ If battery-powered microphones are being affected, ensure that the batteries are fully charged.
- ❑ Keep sensitive equipment on separate electrical circuits if possible.
- ❑ Route intercom wires, microphone wires, speaker cables, etc. away from the oven.

Installation, Specifications, and Maintenance

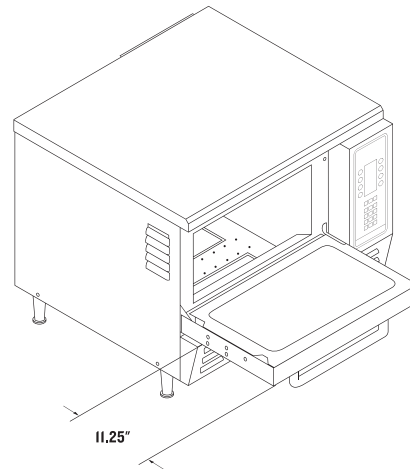
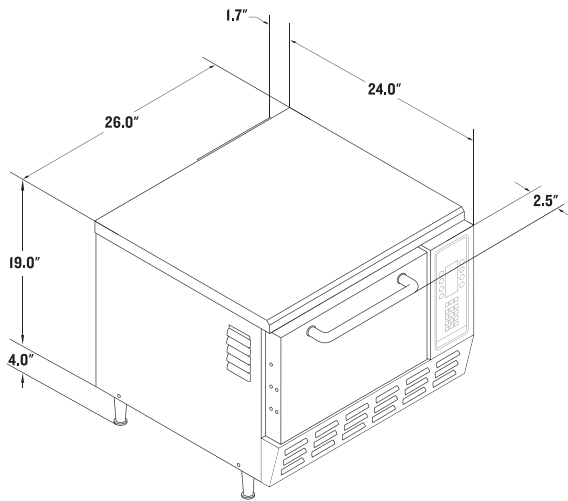

FIGURE 1: NGC (Tornado) Dimensions

SPECS AND DIMENSIONS

Dimensions

| | EXTERIOR | COOK CAVITY |
|-------------|------------------|----------------|
| Height | 19" (483 mm) | 8" (203 mm) |
| with legs | 23" (584 mm) | |
| Width | 26" (660 mm) | 15.5" (394 mm) |
| Depth | 25.7" (653 mm) | 14.7" (373 mm) |
| with handle | 28.2" (716 mm) | |
| Weight | 190 lbs. (86 kg) | |

WALL CLEARANCE

| | |
|-------|------------------------------------|
| Back | 0" (0 mm) unless built-in (page 2) |
| Sides | 2" (51 mm) |

ENTRY CLEARANCE (minimum)

| | |
|----------|----------------|
| Crated | 31.5" (800 mm) |
| Uncrated | 28.7" (729 mm) |

Construction

EXTERIOR

- 430 stainless steel front, top and sides.
- 4" (102 mm) adjustable legs
- Cool to the touch handle

INTERIOR

- 304 stainless steel line
- Fully insulated cooking chamber
- Removable assorted cooking surfaces
- Independently-controlled lower cooking element

Standard Features

- Recirculating airpath with patented catalytic converter system
- Multi-speed convection blower
- Independently-controlled bottom browning element
- Stackable design
- Smart Voltage Sensor Technology (North America only)
- Factory-programmed, customizable menu settings
- Smart Card for remote programming
- Warranty - 1 year parts and labor

Certifications

UL, cUL, NSF, FDA, FCC, TÜV, CE



UL KNLZ Ventless Certification - This product conforms to the ventilation recommendations set forth by NFPA96 using EPA202 test method.

Packaging

All ovens are packaged in a double-wall corrugated box banded to a wooden skid.

Power Supply - North America

SMART VOLTAGE SENSOR TECHNOLOGY

| | |
|-----------|---|
| Voltage: | 208/240 VAC, 60 Hz, 1 phase |
| Amperage: | Nameplate rating 30 Amp (3-wire including ground) |
| Cordset: | 10 gauge, 3 conductor, 5 foot cordset |
| Plug: | NEMA 6-30 |

NOTE: The Smart Voltage Sensor Technology does not compensate for lack of voltage or over-voltage situations. It is the responsibility of the owner to supply voltage to the unit according to the following specifications.

Power Supply - Europe, Asia-Pacific

NGC EW (3-phase)

Voltage: 400 VAC, 50 Hz, Wye, 5-wire (3L + N + Ground)

Circuit Breaker: Type D, min. 20 Amps

NGC ED (3-phase)

Universal Voltage: 230 VAC, 50 Hz, Delta, 4-wire (3L + Ground)

Circuit Breaker: Type D, min. 30 Amps

NGC UK (1-phase)

Voltage: 230 VAC, 50 Hz, 3-wire (2L + Ground)

Circuit Breaker: Type D, min. 30 Amps

Power Supply - Latin America

NGC BK (1-phase)

Voltage: 220 VAC, 60 Hz, 3-wire (2L + Ground)

Circuit Breaker: Type D, min. 30 Amps

Power Supply - Japan

NGC JD (3-phase)

Voltage: 200 VAC, 50/60 Hz, Delta, 4-wire (3L + Ground)

Circuit Breaker: Type D, min. 30 Amps

NGC JK (1-phase)

Voltage: 200 VAC, 50/60 Hz, 3-wire (2L + Ground)

Circuit Breaker: Type D, min. 30 Amps

Power Supply - South Korea

NGC KW (3-phase)

Voltage: 400 VAC, 60 Hz, Wye, 5-wire (3L + N + Ground)

Circuit Breaker: Type D, min. 20 Amps

POWER INPUT

Heaters Input Power (NA) 5990/6675 watts

Heaters Input Power (Intl) 6300 watts

Microwave Input Power 3500 watts*

*Maximum Independent Input Power

DELIVERY AND PRODUCT PLACEMENT

Remove oven from carton. Immediately note any damage and contact shipping company within 24 hours in order to file a claim. TurboChef is not responsible if the product is damaged in shipment. Remove all literature and accessories from the carton.

NOTE: Thoroughly check the carton before discarding.



WARNING: Oven weight is approx. 190 lbs. (86 kg) Two or more persons are required to lift it.

Lifting and Placing the Oven

Position one or more persons on either side of the oven and lift from the bottom. Never lift the oven from the front and rear. Place the oven on a countertop surface at least 28" (711 mm) deep and capable of supporting 200 lbs (91 kg).

Once properly positioned on the counter, plug the oven into wall-mounted electrical receptacle. See page ii for grounding instructions.



WARNING: Never lift the oven by its door handle. Physical damage to the oven and/or personal injury may result. The operator must ensure that the oven is properly placed on the countertop at all times. TurboChef will not recognize a fallen oven as a warrantable claim and is not liable for any injuries that may result.

Built-In Installation (Figure 2)

TurboChef ovens are designed to be installed on a countertop or table. They are not intended for built-in or enclosed installation.

“Built-in or enclosed installation” is defined as installing an oven in any structure that surrounds the oven by five sides (i.e., top/rear/side panels and base).

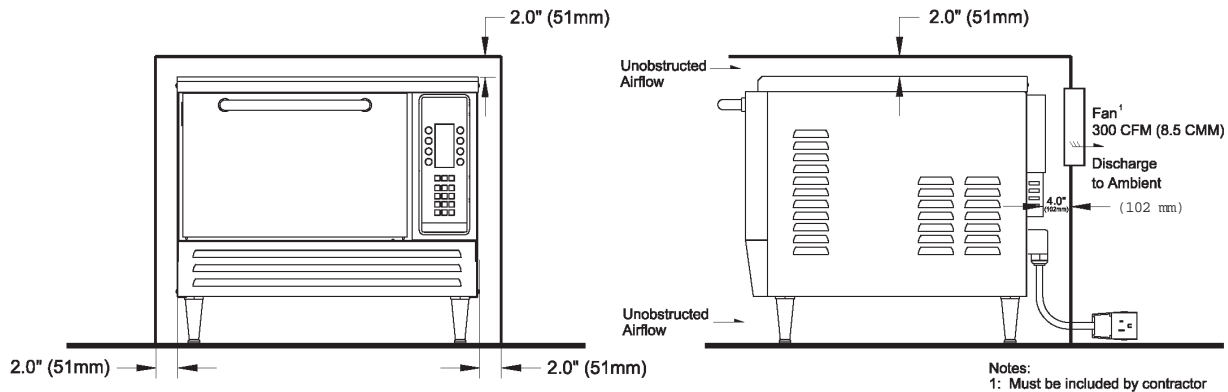

FIGURE 2: Built-in Installation Specs

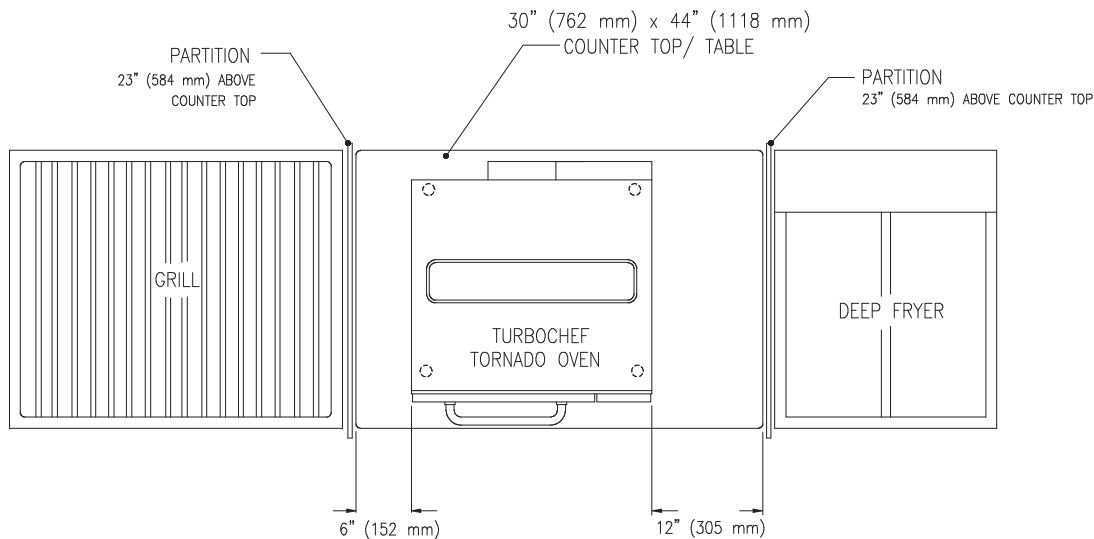

FIGURE 3: Open Heat Source Installation Specs

If installation must be “built in,” the operator must ensure the following:

- Minimum of 300 cfm (8.5 cmm) of supplement flow within the cabinet.
- Minimum clearances of 2" (51 mm) to every surface.

In addition, the operator will be responsible for compensating any extra time required to service the product due to removing the product for serviceability.

Installation Near Open Heat Source (Figure 3)

When placing a TurboChef oven near an open heat source, strictly adhere to the following:

- Verify oven location has a minimum 6" (152 mm) clearance on top and minimum 2" (51 mm) of clearance on each side.
- If the oven is being placed near a grill or stove, there must be a divider between the oven and the open heat source, with a minimum of 6" (152 mm) between the oven and the divider.
- If the oven is being placed near a fryer, there must be a divider between the oven and fryer, with a minimum of 12" (305 mm) between the oven and the divider.
- The height of the divider must be greater than or equal to the height of the oven (23"/584 mm).

Oven Restraint Kit (TC3-0242 KIT)

The Oven Restraint Kit is an optional system that helps prevent the oven from moving forward during use and/or cleaning. It will not prevent the oven from falling off a countertop if the legs are allowed to slide off the edge or if the oven is intentionally or forcefully pulled off.

Proper installation instructions are included with the kit. For additional information, please call customer service at 800.90TURBO / +1 214.379.6000.

Ventilation Requirements

The TurboChef Tornado™ oven has been approved by Underwriter's Laboratory for ventless operation (UL 710B, KNLZ listing) for all food items except for foods classified as "fatty raw proteins." Such foods include bone-in, skin-on chicken, raw hamburger meat, raw bacon, raw sausage, steaks, etc. If cooking these types of foods, consult local HVAC codes and authorities to ensure compliance with ventilation requirements.

NOTE: In no event shall the manufacturer assume any liability for damages or injuries resulting from installations which are not in compliance with the instructions and codes previously listed.

SETUP AND INITIAL OPERATION

Setup

Once the oven is properly positioned on the counter, remove any packing material and/or any foreign objects from within the cavity. Install the oven rack/cooking surface.

Stacking

1. Ensure the surface that will hold the stacked ovens can support at least 400 lbs (181 kg).
2. Allow ovens adequate time to cool and unplug them.
3. If you are stacking ovens on a TurboChef oven cart (24" = [NGC-1217-1](#), 18" = [NGC-1217-2](#)), make sure that the bottom oven is bolted to the cart and the wheels are locked.
4. Attach the stacking bracket (P/N [TC3-0323](#)) to the back of the bottom oven:
 - a. Remove the two screws that hold the top panel to the back of the oven (see bottom arrows on Figure 4).
 - b. Align the holes on the stacking bracket with the holes on the oven and reinstall the screws.

5. Remove the legs of the oven that will be placed on top. This requires two or more persons - at least one person to lift and one to unscrew the legs.
6. Remove the screws from the oven that will be placed on top (see top arrows on Figure 4).
7. Place this oven on top of the other (the one to which the stacking bracket is attached).

 WARNING: Do not attempt to lift the oven with fewer than 2 people.

 WARNING: Do not lift oven from front and back.

8. Align the holes on the bracket with the holes on the top oven and reinstall the screws.

 WARNING: Do not stack ovens over two-high.

Programming

The oven is preprogrammed and ready to operate out of the box.

Initial Power-up

To turn on the oven, press the bottom-right soft key next to the words OVEN ON on the display. The oven will begin to warm up to its pre-defined cooking temperature. This takes approximately 13 minutes.

When the warm-up cycle is completed, the oven will beep and display the READY TO COOK.

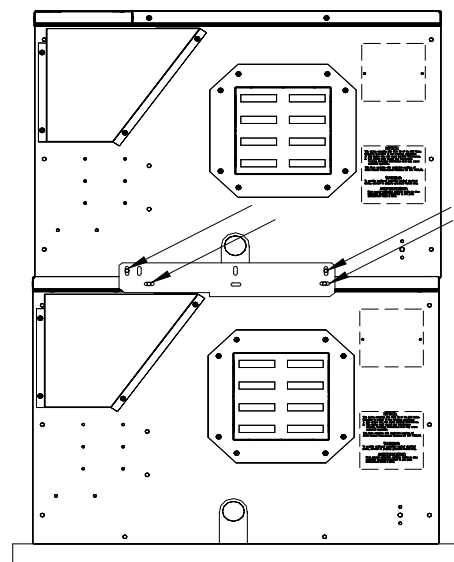
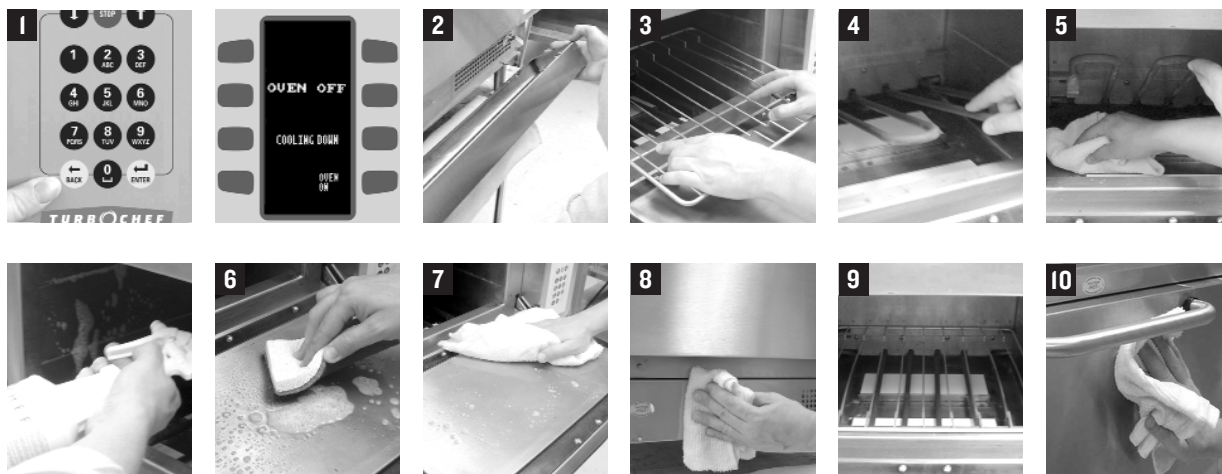

FIGURE 4: Properly Stacked NGC Ovens



DAILY MAINTENANCE FOR THE NGC

Before cleaning, check with the store for custom cleaning instructions.

When cleaning the oven, use only TurboChef Oven Cleaner. Any other cleaning products can damage critical parts and may void warranty on those parts.

Supplies and Equipment

TurboChef® Oven Cleaner (P/N 103180 USA, 103380 Intl), Oven Guard (P/N 103181 USA, 103381 Intl), nylon scrub pad, cleaning towel

Step 1: Prepare the Oven

- Turn oven off by pressing the BACK key.
- The oven will display OVEN OFF/COOLING DOWN.
- ☒ DO NOT attempt to clean oven during the cool down cycle. Cooling takes appx. 90 minutes.

 **WARNING:** The oven operates at appx. 500°F (260°C) and may cause injury if not allowed time to cool properly.

Step 2: Remove the Lower Access Panel

- Wipe out any crumbs that have collected.

Step 3: Remove and Clean the Cooking Surface

- If rack, wash, rinse, and sanitize.
- If baking stone, gently dry-scrub with nylon pad. If the stone gets wet, let it thoroughly air-dry.

Step 4: Lift Bottom Element

- Be sure the bottom element is cool prior to lifting.

 **WARNING:** The bottom element operates at appx. 1000°F (537°C).

Step 5: Remove Particles and Spray Oven Interior with TurboChef® Oven Cleaner

- Using a damp towel, remove large food particles.
- If stubborn stain is present, sparingly spray TurboChef Oven Cleaner onto the stain.
- Allow cleaner to penetrate for five (5) minutes.
- ☒ DO NOT saturate the bottom of the oven with water or oven cleaner.

Step 6: Clean Oven Interior

- Using a nylon scrub pad, clean the oven door and cook cavity.

 **CAUTION:** DO NOT apply pressure to the wave guide covers. Breaking will result in a non-warranty service call.

Step 7: Wipe Out Oven Interior

- Wipe oven door, bottom element, and cook cavity using a damp towel.

Step 8: Clean Lower Access Panel Area

- ☒ DO NOT spray any chemical in this area.

Step 9: Lower the Bottom Element and Reinstall the Cooking Surface and Lower Access Panel

Step 10: Apply Oven Guard and Clean Oven Exterior

- Spray Oven Guard on towel. Wipe sides of cook cavity and inside of door.
- ☒ DO NOT spray Oven Guard directly into cook cavity or wipe on nozzle plates/bottom element.
- Wipe the oven exterior with a clean, damp towel.
- Oven is ready to turn on.

Theory of Operation

THEORY OF OPERATION

The TurboChef® NGC (Tornado®) oven utilizes three independent heat transfer mechanisms to rapidly cook food.

The systems are as follows:

- Convection
- Infrared energy
- Microwave energy

By combining these mechanisms along with the ability to control each mechanism independently, the NGC (Tornado) oven is able to reduce the cook time of most foods by 70-90 percent.

Figure 5 below represents the oven's different systems and the critical components of each system.

Should a problem arise with any of the components listed below, please turn to the appropriate section within this manual for further instructions.

For the purpose of this manual, each independent heat transfer mechanism is individually identified. For instance, if an oven is experiencing difficulties browning the food, focus on CONVECTION SYSTEM and/or BOTTOM IR AND CCV. Focus on MICROWAVE SYSTEM if the oven is browning the food but not heating the inside.

Part numbers are included on illustrations (where applicable) and in the back of this manual. If an item is not illustrated, the part number is provided in the text.

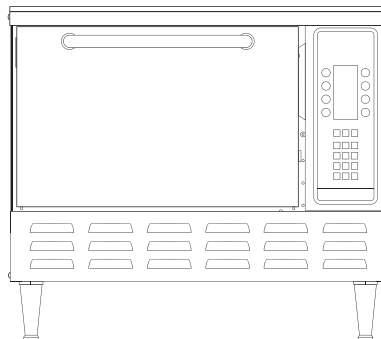

Chapter 4 CONTROL SYSTEM

I/O Control Board
Keypad
Display
Mechanical Relays
Solid State Relay

Chapter 5 MICROWAVE SYSTEM

Magnetrons
High Voltage Transformers
Filament Transformers
High Voltage Capacitors
High Voltage Diodes
Fuses

Chapter 7 CONVECTION SYSTEM

Convection Heater
Blower Controller
Blower Motor
Hi-Limit Thermostat

Chapter 8 BOTTOM IR AND CCV

Bottom Infrared Element
Catalytic Converter

FIGURE 5: NGC (Tornado) Systems and Critical Components

GLOSSARY OF COMMON OPERATING TERMS**Off State**

All the oven's control systems are off and the cook cavity temperature is below 150°F (66°C).

Cool Down

A subset of the OFF STATE. During COOL DOWN, the oven will circulate the main convection blower until the cook cavity temperature is below 150°F (66°C).

Ready State

The oven has successfully warmed to the predefined set temperature. At this point the oven control is ready to receive cook commands via the keypad. The oven will maintain the set temperature in the READY STATE.

Set Temperature, Cook Cavity (CCSP)

Predefined temperature of the cook cavity at which the oven cooks.

Set Temperature, IR Element (IRSP and IRSI)

IRSP is the set temperature of the IR element during a given cook cycle. Settings are determined on a per-recipe basis. IRSI is the set temperature of the IR element during the READY STATE (or "idle"). IRSI setting can be adjusted in the TEST MODE (page 16).

Actual Temperature, Cook Cavity (TCC)

The actual temperature registered by the cook cavity thermocouple.

Actual Temperature, IR Element (TIR)

The actual temperature registered by the IR element.

Edit Mode

Enables the user to change recipe and CCSP/IRSP temperature settings.

Warm-Up

The mode in which the oven warms itself to the set temperature.

Soak

The mode in which the oven temperature has reached the CCSP, and remains in warmup for an additional 8 minutes to allow cook cavity surfaces to warm. The oven will proceed to soak only if warm-up was initiated when $TCC < (CCSP - 126^{\circ}F)$ or $TCC < (CCSP - 66^{\circ}C)$.

Cook Cycle

A period of operation as defined by a recipe.

Test Mode

A special diagnostic mode that enables the service technician to turn on and off all oven systems independent of one another, check oven statistics, and set the IRSI.

Keypad

The primary interface for the operator.

Display

Displays all visual information to the operator.

Self-Test (STEST)

A special diagnostic function that tests all critical subsystems to determine their operational state.

Recipe

A set of user-defined Events that determine a cook cycle.

Events

A single operational element that is a part of a recipe. Each recipe may have up to six events depending on programming. Each event can be set between 0 and 100% of the total cook time.

Total Cook Time

The total duration of a recipe.

Percentage (%) Time

An event subset that specifies the duration of the event. The sum of all event time percentages for a recipe must equal 100%.

Percentage (%) Air

An event subset that specifies the relative amount of impingement airflow (speed of convection motor) during an event. Valid between 10 and 100%.

NOTE: Maximum 100% = 7100 RPM blower motor speed. Blower motor speed scale is linear.

Percentage (%) Microwave (WAV)

An event subset specifying the microwave cycle during the event. Valid between 0 and 100%. For example, if WAV is set to 30%, then microwave would be present in the cook cycle for 3 out of every 10 seconds.

Fault Code

A code assigned to an instance that the control considers to be a failure. Upon discovering a fault, the control will display the fault code and a brief description of the failure. The oven will also log faults F1 through F6 in the Fault Log. See page 11 for more detail on faults and for viewing the fault log.

Fault Codes

The NGC (Tornado®) oven has the ability to continually monitor and log various fault conditions. Some fault conditions will terminate cook cycles, while others will not. Please refer to the fault code table on page 12 for more detailed information.

When a fault is detected, the Fault Log will increment. However, if the fault is subsequently cleared by some action, whether service related or not, the Fault Log will not decrement.

TO VIEW FAULT CODES

To view the Fault Log, simultaneously press the “4” and “6” keys while the oven is in the OFF STATE. The oven will display all faults logged. Figure 6.

Each fault will log up 255 instances before rolling back to zero. To zero the log, see pages 14-15 (TEST MODE).

NOTE: The Fault Log also displays cook counts, which will log up to 65,535 cook cycles. In order for the control to log a cook cycle, the oven must complete the first event of any given recipe. If a recipe has only one event, the oven must complete the entire cook cycle in order to count it.

FAULT CODE DEFINITIONS

F1: Blower Running Status Bad

Fault is displayed when the motor controller indicates no running status.

The motor and motor controller are monitored continuously in all modes with special handling in SELF TEST and TEST MODE. If a fault is detected, the control will terminate a cook cycle and display F1: BLOWER. Upon turning on the oven, the control will attempt to restart the motor. If the restart is successful, the fault code will be cleared. The fault is also cleared from the display at the onset of cooking or when the blower motor is tested in TEST MODE.



FIGURE 6: Fault Log

F2: Cook Temperature Low

Fault is displayed if the cook cavity temperature is more than 84°F (47°C) below the set temperature after five (5) seconds into a cook cycle.

The fault is cleared from the display at the onset of cooking if the cook cavity temperature is within 84°F (47°C) of the set temperature or when the heater is tested in the TEST MODE.

F3: Magnetron Current Low

Fault is displayed when the current transformer (CT) on the I/O control board does not detect enough current. The fault is monitored when the microwave is on during a cook cycle or self-test.

The fault is cleared from the display at the onset of a cook cycle if the CT detects current or when the magnetron is successfully energized in TEST MODE.

F4: Door Monitor Defective

Fault is displayed when the control detects that the monitor interlock switch unlatches before the primary or secondary interlock switches.

In addition, this fault will blow the F3 fuse if the microwave high voltage system is energized when the fault occurs. The fault is cleared from the display when the oven is powered off and then back on.

NOTE: Door interlock switches are in parallel. See OVEN SCHEMATICS, pages 55-63. The fault is monitored during a cook cycle, or in SELF TEST when the microwave is on.

F5: Magnetron Over Temperature

Fault is displayed when either magnetron thermostat is “open.”

The fault is cleared from the display at the onset of a cook cycle if the thermostat is closed or when the magnetron is successfully tested in TEST MODE.

F6: EC (Electrical Compartment) Temperature High

Fault is displayed when the EC thermocouple exceeds 158°F (70°C). It is monitored once per minute.

The fault is cleared from the display when the EC

thermocouple temperature is below the indicated limit.

F7: Thermocouple Open

Fault does not log in counter. Fault is displayed when the control detects that either the IR or CC thermocouple is “open.”

- 999°F/C indicates CC thermocouple is “open.”
- 1999°F/C indicates IR thermocouple is “open.”

Fault is cleared when the control detects continuity on the open thermocouple circuit.

F8: Heat Low

Fault is not logged in counter. Displays during WARM UP or SELF TEST if the cook cavity temperature (TCC) fails to rise at least 14°F (7°C) within a given thirty (30) seconds.

FAULT CODE TABLE

| FAULT CODE AND DESCRIPTION | WHEN ACTIVE | | | | REFER TO |
|---------------------------------------|-------------|-----------|-----------|-----------|-------------|
| | Warm - up | Idle Mode | Cook Mode | Self-Test | |
| F1: Blower Running Status Bad | X | X | X | X | Page 22 |
| F2: Cook Temperature Low | | | X | | Page 23 |
| F3: Magnetron Current Low | | | X | X | Page 34 |
| F4: Door Monitor Defective | | | X | | Page 46 |
| F5: Magnetron Over Temperature | | | X | X | Page 28 |
| F6: EC Temperature High | X | X | X | | Page 14 |
| F7: Thermocouple Open | X | X | X | X | Page 21 |
| F8: Heat Low | X | | | X | Page 22, 49 |

Fault codes are listed in order of hierarchy. For example, if during cooking the oven experiences an F1 and F2 fault, the oven will report only the F1 fault because the software will halt all actions upon discovering the F1 fault. F7 and F8 faults are displayed on the primary screen and are not displayed or counted in the Fault Log.

NOTE: All Fault codes listed in **bold** will terminate a cook cycle upon discovery. Any fault occurring in a cook cycle will be logged in the Fault Log.

The Control System

The Control System is comprised of the components that signal, sense, command, and switch the oven's various components. Figure 7 shows a functional diagram of all the components that make up the Control System.

NOTE: The part numbers for each component can be located on the drawings found throughout and at the end of this manual.

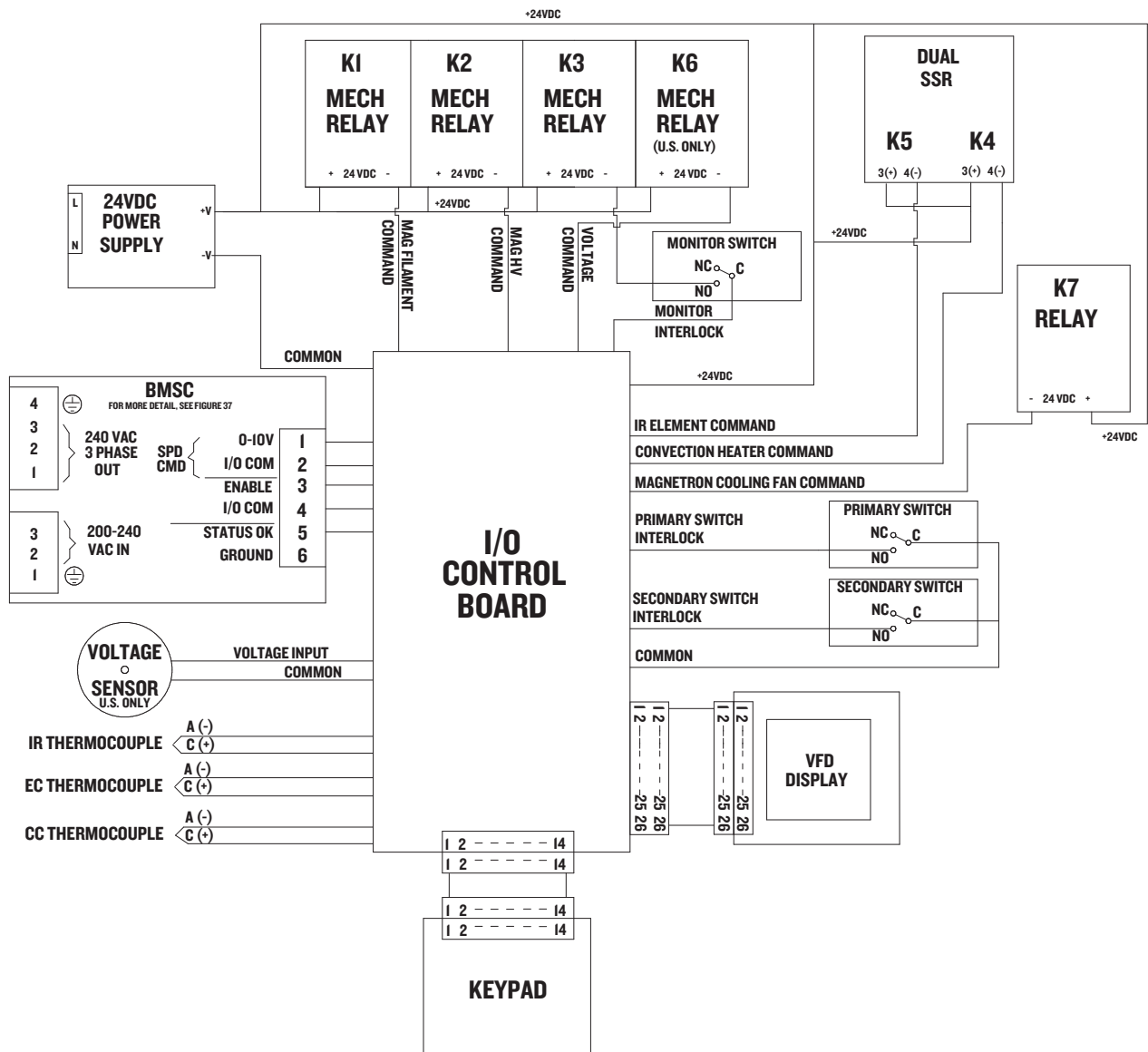

FIGURE 7: NGC (Tornado[®]) Control System

CONTROL SYSTEM COMPONENT DESCRIPTIONS

24 VDC Power Supply

24 VDC output at 40 watts. Supplies control voltage for I/O control board, 24 VDC mechanical relays, and solid state relays.

K1 Mechanical Relay

240 VAC, 30 Amp, Double Pole, Double Throw, 24 VDC Relay Coil. Switches power to the magnetron filament transformers.

K2 Mechanical Relay

240 VAC, 30 Amp, Double Pole, Double Throw, 24 VDC Relay Coil. Switches power to the magnetron high voltage transformers.

K3 Mechanical Relay

240 VAC, 30 Amp, Double Pole, Double Throw, 24 VDC Relay Coil. Safety interlock device designed to short L1 and L2 if the monitor switch opens before the primary or secondary interlock switches.

K4/K5 SSR

240 VAC, Dual 40 Amp Solid State Relay. K4 (right) controls the convection heater and K5 (left) controls the IR element.

K6 Mechanical Relay (North America Only)

240 VAC, 30 Amp, Three Pole, Double Throw, 24 VDC Relay Coil. Responsible for switching between the 208VAC and 240VAC taps on the high voltage and filament transformers.

K7 Relay

24 VDC, 20 Amp, Sealed. Starts with command from I/O board; switches magnetron cooling fan on and off. Timer for switching off mag fan is 4:15 after filament switches off.

Interlock Switches

Primary, Secondary, and Monitor Interlock Switches. Must be actuated by the oven door. When the door opens, the order is: P, S, M.

IR Thermocouple

Type K Thermocouple. Embedded in the IR element, the IR thermocouple measures the internal/sheath temperature of the IR element. Valid IR set points are between 500°F (260°C) and 1150°F (621°C). The display indicates 1999°F/C if the thermocouple is “open”.

EC Thermocouple (P/N 700-1199)

Type K Thermocouple. Thermocouple measures the temperature of the electrical compartment. If the temperature within the electrical compartment is above 158°F (70°C), the control displays F6: EC TEMP. The control board checks the EC temperature every 60 seconds.

CC Thermocouple

Type K Thermocouple. Thermocouple measures the temperature of the re-circulating impingement airflow. Valid CC set points vary depending on software. If the display indicates 999°F/C, the thermocouple is “open.”

BMSC

Proprietary Brushless DC Motor Controller. Designed solely to operate the blower motor.

VFD (Display)

Vacuum Fluorescent Display.

Keypad

5x9 Matrix Membrane Switch. Keypad is connected to the I/O control board via 14-pin flat cable.

Voltage Sensor (North America Only)

Proprietary device designed to measure incoming line voltage and switch between 208 and 240 VAC operation. The device measures and allows the user to configure the oven only when the oven is first powered on. Voltage sensor will default at 240 VAC.

TEST MODE

The Test Mode allows the service technician to operate the oven's subsystems individually. It also allows the operator to configure various presets.

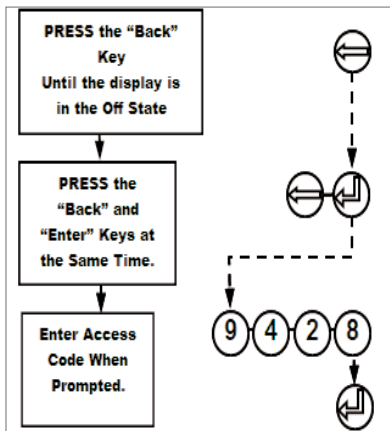

FIGURE 8: Accessing Test Mode

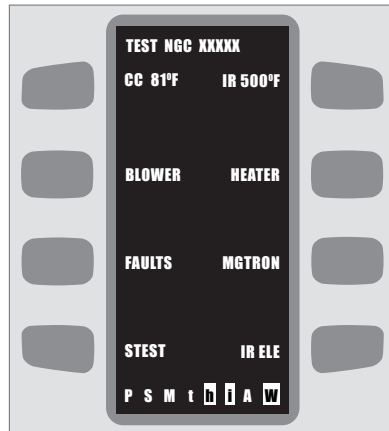

FIGURE 9: Test Mode - Screen 1



FIGURE 10: Test Mode - Screen 2

To enter TEST MODE (Figure 8):

1. Press the BACK key until the display is in the OFF STATE.
2. Simultaneously press BACK and ENTER keys.
3. When prompted, enter the access code: 9-4-2-8 and press ENTER.

The TEST MODE displays the software version, actual cook chamber temperature, and actual IR element temperature at the top of the screen. The TEST MODE consists of 2 screens (Figures 9 and 10). To display the second screen, press either the UP or DOWN key. To test a component or sub-system, press the corresponding soft key.

TEST FUNCTION OPTIONS

Blower Speed (Screen 1)

The BLOWER key increments the blower motor speed in 10% increments. When the speed is 100%, the next press sets the speed to 0%.

NOTE: If this function is being used to expedite cooling, open the oven door to further expedite.

Faults (Screen 1)

Pressing the FAULTS soft key will display all the accumulated faults in the Fault Log. Press "0" to zero the fault counter. For more information, see page 11.

Self-Test Function (Screen 1)

The STEST key initiates a self-test to test all major components of the oven (including door switches). To run the self-test, press the corresponding soft key once. Press the BACK key to return to the OVEN OFF/COOLING DOWN mode.

Heater Test (Screen 1)

Press the HEATER key to turn the heater on. Heater will remain on until key is pressed again to turn it off. If the blower speed is 0, the blower speed is set to idle airflow (10%).

Magnetron (Screen 1)

Press and hold the MGTRON key to test the magnetrons. Doing so requires a 5-second warm-up period. Once the MGTRON key is released, the high voltage supply is switched off to the magnetron and the magnetron will stop radiating; however, the power is still supplied to the magnetron cooling fan for an extra 4 minutes, 15 seconds.

IR ELE (Screen 1)

Pressing the IR ELE key will turn on the IR element. When pressed, the screen will read IR ELEMENT ON. Press the IR ELE key again to turn it off.

Diagnostic Display (Screen 2)

The DIAG key turns on or off the diagnostic display feature. When this feature is enabled, the oven will display temperature and cook cycle parameters when the oven is cooking or idle.

In addition, the status indicators are displayed on the bottom of the screen. When a status indicator is highlighted/backlit the corresponding system is **off** or **open**. For example: **W** would indicate that the Microwave System is off.

The STATUS INDICATOR section below offers a more detailed description of each indicator.

COOKS (Screen 2)

Press once to display the total number of cook counts for all recipes. Press again to display the total amount of time the oven has been in cook cycles.

ACCUM (Screen 2)

Press once to display the total amount of time the magnetrons have been on. Press again to display the total amount of time the oven has been on.

Electronic Compartment Temperature (Screen 2)

The °ELEC key displays the temperature inside the electronic compartment.

F/C (Screen 2)

Changes how the oven's temperature units are displayed. The F/C key alternately selects Fahrenheit or Celsius.

IR SI (Screen 2)

Displays the idle IR set point. This temperature is a factory setting and should never be altered. If an incorrect temperature has been entered, consult the factory before changing this value.

STATUS INDICATORS

See Figures 9 and 10 on page 15.

| | |
|---|---|
| P | Primary switch – closed or open |
| S | Secondary switch – closed or open |
| M | Monitor switch – closed or open |
| t | Magnetron thermostats – closed or open |
| h | Main convection heater – off or on |
| i | IR element – off or on |
| A | Blower motor controller – enabled or disabled |
| W | Microwave current – Less than or greater than 7 Amps* |

* Microwave (W) status indicator is not highlighted/backlit when the current is more than 7 Amps.

Status indicators are displayed at the bottom of the display screen when the oven is in TEST MODE, or during normal oven operation if in DIAGNOSTIC MODE (DIAG was turned on). Refer to Figures 9 and 10.

If a status indicator is highlighted/backlit, the item or component is in an un-energized or off state. Conversely, if a status indicator is not highlighted, the component is in an energized or on state.

PROGRAMMING**Edit Mode**

The EDIT MODE enables the operator to manually alter recipes and the cook cavity temperature (CCSP).

To access EDIT MODE:

1. Simultaneously press the UP and DOWN keys.
2. When prompted, enter the access code "9" and then press the ENTER key.

NOTE: If this does not provide access, refer to page 19 for enable/disable codes.

Changing the Cook Chamber Temperature

This temperature is a factory setting - exercise caution before altering it. For best results, consult the factory before changing this value.

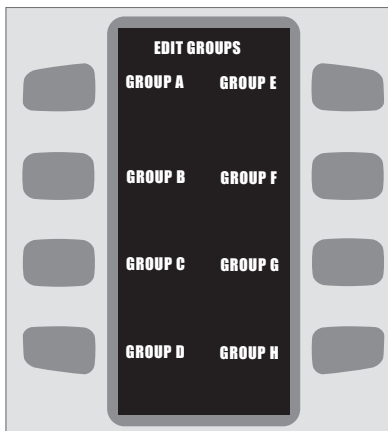

FIGURE 11: Select Group

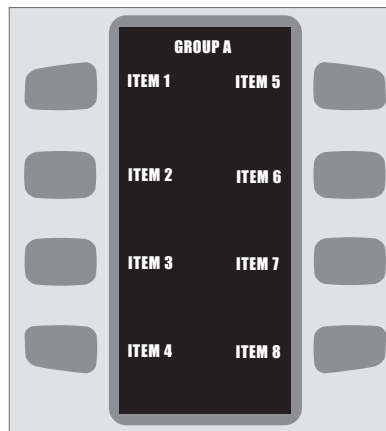

FIGURE 12: Select Recipe

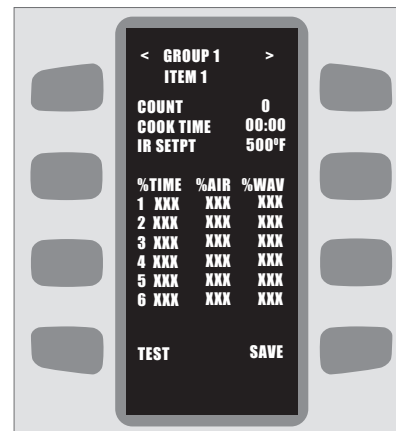

FIGURE 13: Edit Recipe Settings

To change the cook cavity temperature (CCSP), press the UP and DOWN keys. Temperature ranges vary depending on software. Once you have selected the correct temperature, press the ENTER key to confirm and advance to the next screen.

Altering a Recipe

Most NGC (Tornado) oven models contain 128 unique recipes. The display shows two (2) pages each with eight (8) recipe groups. Each recipe group contains eight (8) recipes. See Figures 11 and 12.

To alter a recipe:

1. Enter the EDIT MODE (see page 16).
2. Enter the access code “9” and set the CCSP. The screen displays the first set of eight (8) recipe groups. To access the second set of eight (8) recipe groups, press either the UP or DOWN key.
3. Select the recipe group that contains the individual recipe you wish to alter. Select the recipe you wish to alter by pressing the soft key corresponding to the recipe item. Figures 11 and 12.
4. Use the UP and DOWN keys to navigate through the recipe settings. Use the keypad and ENTER key to alter any of the following three (3) parameters (see Figure 13):

- a. Cook time
Total duration of the cook cycle. Enter the desired time and press ENTER.
 - b. IR element temperature (IRSP)
The temperature the lower radiant element will maintain during the entire cook cycle. Valid temperatures are between 500°F (260°C) and 1150°F (621°C).
 - c. Events 1...6
Use the keypad and ENTER key to enter values for % TIME, % AIR, and % WAV.
 - Sum of % TIME for all events must = 100. The operating system will not allow a combination of events not equal to 100%.
 - The % AIR parameter is valid between 10 and 100%.
 - The % WAV (microwave) parameter is valid between 0 and 100%.
5. After making changes, test the recipe by pressing the TEST soft key. Once the oven has warmed to the CC set point, press the TEST soft key again to begin the test cook.
 6. Once satisfied with the recipe, press SAVE to permanently store changes.
 7. Press the BACK key until exited from EDIT MODE.

Loading a Menu from a Smart Card

1. Ensure the oven is in the OVEN OFF/COOLING DOWN mode.
2. Enable the LOAD MENU function (page 19). The oven will return to the Off screen.
3. Remove the lower access panel (Figure 14).
4. Insert smart card into oven (Figure 14).
5. Press the bottom-left soft key.
6. Select LOAD MENU FROM CARD. The menu on the smart card will load to the oven.
7. When this process completes, the oven will beep. Remove the smart card and reattach the lower access panel.
8. If the oven is a Subway oven, disable the LOAD MENU function (page 19). For all other ovens, leave it enabled.

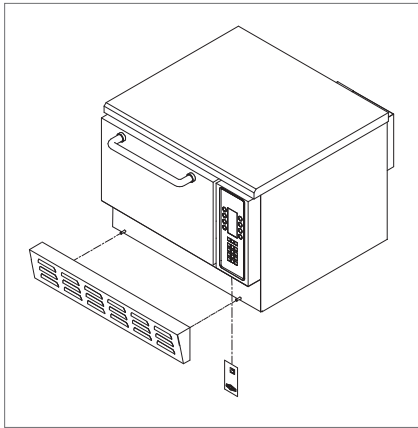

FIGURE 14: Inserting Smart Card

OVEN OPTIONS

Done Screen

To enable/disable the Done Screen (Figure 15), see the next page. Enable the Done Screen to:

- Cook an item longer after the end of a cook cycle.
- Save an adjusted cook time (only if Time Screen is also enabled).

Time Screen

To enable/disable the Time Screen (Figure 16), see the next page. Enable the Time Screen to:

- Adjust the cook time before initiating a cook cycle.
- Save an adjusted cook time.

Snooze Mode

To enable/disable the Snooze Screen, see the next page. Enabling the Snooze Screen will allow the operator to set the oven in a mode during which all oven operations are turned off, but the heaters remain on. The cook cavity will remain at the set temperature, and the IR temperature will drop 200°F (104°C) below the IRSI. This allows fast recovery when the oven is again turned on.

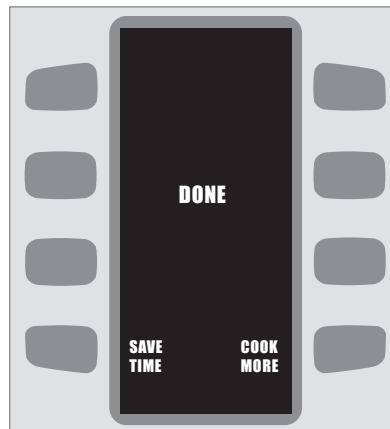

FIGURE 15: Done Screen

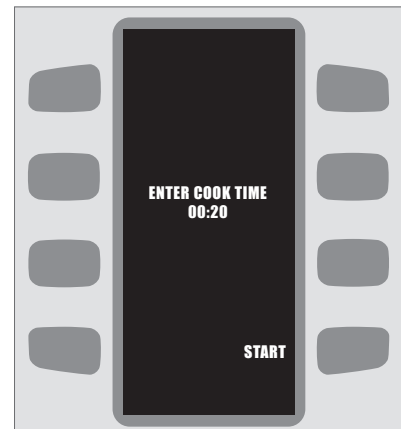

FIGURE 16: Time (Start) Screen

USER CONFIGURABLE OPTIONS - ENABLE/DISABLE CODES

The following codes enable and disable each function/screen listed. They do not take you to the function/screen.

After each code, press ENTER. To enable, press 9 after entering code (except S-A-V-E, W-A-V-E). To disable, press any key (except 9) after entering code.

| Function/Screen | Simultaneously Press | Enter Key Code |
|-------------------------------------|-----------------------------|-----------------------|
| Done Screen w/out "Save Time" | BACK & ENTER | 3-6-6-3 (D-O-N-E) |
| Done Screen w/ "Save Time" - step 1 | BACK & ENTER | 3-6-6-3 (D-O-N-E) |
| Done Screen w/ "Save Time" - step 2 | BACK & ENTER | 8-4-6-3 (T-I-M-E) |
| Edit Recipe Mode | UP & DOWN | 8-4-3-3 (T-I-D-E) |
| Load Menu from Card | BACK & ENTER | 6-3-6-8 (M-E-N-U) |
| Save Menu to Card - step 1 | BACK & ENTER | 6-3-6-8 (M-E-N-U) |
| Save Menu to Card - step 2 | BACK & ENTER | 7-2-8-3 (S-A-V-E) |
| Snooze Screen | BACK & ENTER | 7-6-6-9 (S-N-O-Z) |
| Time Screen (Figure 16) | BACK & ENTER | 8-4-6-3 (T-I-M-E) |
| Timed Mag Test | BACK & ENTER | 9-2-8-3 (W-A-V-E) |

- Some codes are not available on some ovens.

- Oven must be in Off or Cooling Down mode.

USER CONFIGURABLE OPTIONS - ACCESS CODES

The following codes allow access to each function/screen listed. To enable/disable these codes (where applicable), see above. After each code, press ENTER.

| Function/Screen | Simultaneously Press | Enter Key Code |
|------------------------|-----------------------------|---|
| Edit Recipe Mode | UP & DOWN | 9 (or as specified - see "Set PIN" below) |
| Erase Menu* | BACK & ENTER | 3-7-2-7 (E-R-A-S) |
| Load Menu from Card | | Bottom-left, then upper-mid soft key |
| Master Reset | BACK & ENTER | 9-4-7-1 |
| Save Menu to Card | | Bottom-left, then lower-mid soft key |
| Set PIN** | UP & DOWN | 3-3-4-8 (E-D-I-T) |
| Test Mode | BACK & ENTER | 9-4-2-8 (W-H-A-T) |
| Unit Test | BACK & ENTER | 8-6-4-8 (U-N-I-T) |
| View Cook Counts | 1 & 3 | |
| View Faults*** | 4 & 6 | |
| Zero Cook Counts* | BACK & ENTER | 6-7-3-9 (O-R-E-Z) |

- Oven must be in Off or Cooling Down mode.

* To execute, press 3 after entering code.

** Set PIN after entering code. Accessing "Edit Recipe Mode" will now require new PIN instead of 9.

*** To view voltage, press ENTER. To initiate a self test, press the corresponding soft key from the voltage screen.

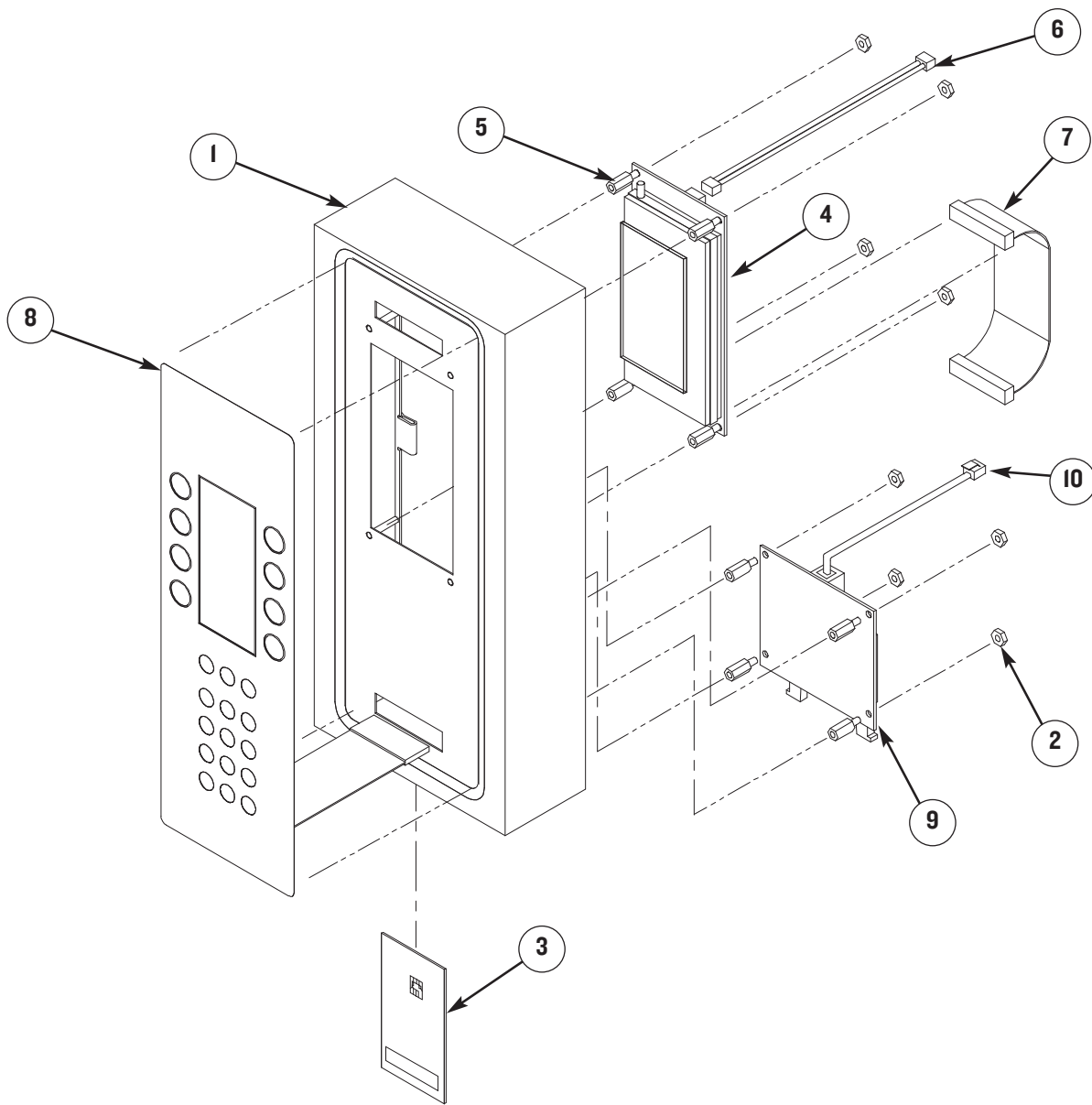

FIGURE 17: Control System Panel Enclosure and Parts

CONTROL SYSTEM PANEL PARTS

Figure 17.

- | | | |
|----|-----------------|---|
| 1. | NGC-1040 | Cover, Keypad/Display, Std |
| | NGC-1209 | Cover, Keypad/Display, SBK |
| 2. | 102960 | Nut, 4-40, Stainless |
| 3. | 100508 | Smart Card, Blank |
| | (Varies)* | Smart Card, Programmed* |
| 4. | NGC-3023 | Display Svc Kit (includes Items 5, 6, and 7) |
| 5. | 101954 | Spacer, 1/2" Lg, Aluminum |

- | | | |
|-----|-------------------|-------------------------|
| 6. | 100193 | 3-Pin Power Cable |
| 7. | 100184 | 26-Pin Ribbon Cable |
| 8. | NGC-1110-1 | Keypad, NGC, Standard |
| | NGC-1110-2 | Keypad, NGC, SWY |
| | NGC-1110-3 | Keypad, NGC, SBK |
| | NGC-1110-4 | Keypad, NGC, OUT |
| 9. | 100506 | Smart Card Reader |
| 10. | 100182 | Smart Card Reader Cable |

* Contact TurboChef (800.90TURBO or +1 214.379.6000) for more info/part numbers.

CONTROL SYSTEM TROUBLESHOOTING

| ISSUE | RESOLUTION |
|--|---|
| No Display (Blank) | <ol style="list-style-type: none"> 1. Verify power 208 VAC or 240 VAC is going to the oven correctly. If not, correct the voltage supply. 2. Control DOES NOT beep when any key on the keypad is pressed. Check power going to the 24VDC power supply. Supply must have 208 or 240 VAC across L and N terminals. <ul style="list-style-type: none"> □ If there is no voltage, replace F1 and F2 fuses. □ If the voltage is OK, verify output of power supply is 24 VDC. If there is no output, change the power supply. If the power supply is 24 VDC, see below. <p>Output is 24VDC: Verify I/O control board has 24 VDC by checking the voltage on the D6 diode (striped end) on the I/O control board to chassis. Reference page 54 for a schematic of the I/O control board.</p> <ul style="list-style-type: none"> □ No voltage: Check wires from power supply to I/O control board. □ Voltage is 24VDC, but 5VDC is not present on the I/O control board J3 connector: Replace I/O control board. 3. The control DOES beep when any Key on the Keypad is pressed. Check all connections between the I/O control board and display. Correct any loose connections. If connections are OK and 5 VDC is present on the J3 connector, but there is still no display, replace display. |
| No Keypad Input | <ol style="list-style-type: none"> 1. Check keypad ribbon cable going to the I/O control board. <ul style="list-style-type: none"> □ Cable and connection bad: Replace keypad. □ Cable and connection OK: Replace the I/O control board. |
| F7: Thermocouple Open CC Thermocouple Reads 999°F/C or IR Thermocouple Reads 1999°F/C | <ol style="list-style-type: none"> 1. Check the connection of open thermocouple on the I/O control board. If the connection is OK, verify thermocouple is not an open circuit by using your ohm meter. The cook cavity thermocouple should measure approximately 4-5 ohms and the IR thermocouple should measure approximately 30-40 ohms. Measure at the I/O control board 40-pin connector. <ul style="list-style-type: none"> □ Thermocouple indicates open circuit: Replace defective thermocouple. □ Thermocouple OK: Replace the I/O control board. <p>NOTE: F7 fault is not logged in the fault counter.</p> |

| ISSUE | RESOLUTION |
|--|--|
| <p>F1: Blower Running Status Bad</p> <p>Motor not running when commanded.</p> | <ol style="list-style-type: none"> Status Indicator “A” is highlighted/backlit in TEST MODE. Verify 208 or 240 (USA) / 230 (Intl) / 200 (Japan) / 220 (Latin America) VAC is going to the motor controller via pins 2 and 3. <ul style="list-style-type: none"> 208/240/230 VAC is present: Verify control wiring from the motor controller and I/O control board, specifically low-voltage wire OR-9. If all wires are OK, then refer to page 50 for motor controller troubleshooting. 208/240/230 VAC is not present: Correct wiring going to the motor controller. Also, check fuses. Status Indicator “A” is still highlighted in TEST MODE. Refer to page 50 for motor controller troubleshooting. |
| <p>F3: Magnetron Current Low</p> | <ol style="list-style-type: none"> Ensure the K2 mechanical relay is in good working order. If relay is OK, refer to pages 34-35 (F3: MAGNETRON CURRENT LOW) for detailed troubleshooting. |
| <p>F8: Heat Rise Low</p> <p>NOTE: This message occurs in WARM UP and SELF TEST if the oven fails to warm up in the pre-determined time period.</p> | <ol style="list-style-type: none"> Verify the high-limit thermostat is not tripped. <ul style="list-style-type: none"> If high-limit is tripped, reset and allow the oven to warm up. If high-limit is not tripped, proceed to instructions below. <p>High-limit thermostat is not tripped: Check both K4 and K5 SSRs by activating them in TEST MODE (activate HEATER and IR ELE). When actuated, the (-) control input of the SSR will go to 0.00 VDC. When the relay is not actuated, the input will read -24.00 VDC.</p> <ul style="list-style-type: none"> If the control voltage is not pulled down during actuation, verify the wiring between SSR and I/O control board. Replace SSR if wiring is OK. If the control voltage is pulled down: Refer to Figure 37 on page 47. |

| ISSUE | RESOLUTION |
|--------------------------|---|
| F2: Cook Temperature Low | <p>1. Verify the high-limit thermostat is not tripped.</p> <ul style="list-style-type: none">□ If high-limit is tripped, reset and allow the oven to warm up.□ If high-limit is not tripped, follow the instructions below. <p>High-limit thermostat is not tripped.</p> <p>Place a small water load in a microwave/heat-resistant container (approx. 275 ml) in the oven and place the oven in TEST MODE. Press the MGTRON key to actuate the microwave. While holding down the MGTRON key, watch the CC and IR temperatures. If either temperature bounces substantially, there may be a noise (EMI) problem.</p> <p>To correct this problem, examine the wire routing for each thermocouple wire. If the wires are routed near any high voltage components such as the magnetron or high voltage transformers, re-route the wires. If this does not correct the problem, verify that both magnetrons are securely mounted. Call Technical Support for further details at 800.90TURBO or +1 214-379-6000.</p> |

The Microwave System

The Microwave System is the most complex system in the oven. Proper care must be taken during servicing to protect both the operator and technician.

VOLTAGE DOUBLER CIRCUIT DESCRIPTION

The Microwave System consists of a magnetron and Voltage Doubler Circuit. The Voltage Doubler Circuit consists of a special step-up transformer, a capacitor, and a diode.

MONITOR CIRCUIT DESCRIPTION

In addition to understanding the Voltage Doubler Circuit, it is imperative to understand how the Monitor Circuit operates. The Monitor Circuit is a failsafe circuit designed to protect the operator if both the primary and secondary interlock switches fail to operate normally.

The Monitor Circuit consists of the primary and secondary interlock switch, monitor safety switch, monitor relay, and the F3 fuse. When the oven door closes during normal operation, the monitor, secondary, and primary switches close in the order listed above. When all switches are closed, the Microwave System is allowed to operate.

If during normal operation any of the interlock switches open - such as when the oven door opens - the control will turn off the microwave. If the monitor switch opens before the primary or secondary switches (abnormal operation), the monitor switch de-energizes the monitor relay. When this occurs, a dead short is placed across L1 and L2. The short then blows the F3 fuse, which permanently interrupts power to the Microwave System until all switches are repaired and/or functioning properly.

Figure 18 shows a schematic of the Monitor Circuit. Make sure to note the following:

- Primary and secondary switches interlock the high-voltage control signal. (K2 relay)
- Normal operation: When the K2 and K3 relays energize, power is supplied to the high-voltage transformers.
- Abnormal operation: When K2 is energized and K3 is un-energized (via an opening of the monitor switch), L1 and L2 short to blow the F3 fuse and failsafe.

Figure 19 on the following page details the theory of operation of the Voltage Doubler Circuit.

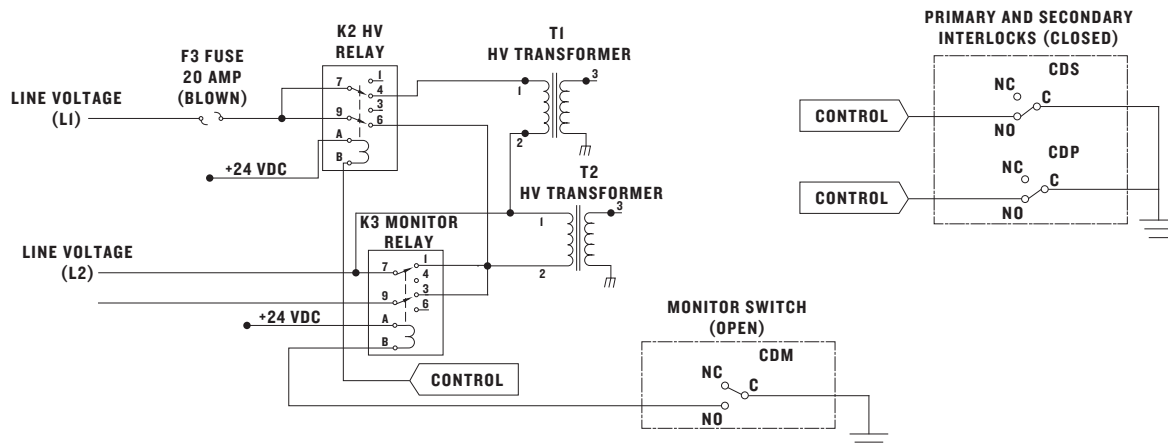

FIGURE 18: Monitor Circuit - shown in failsafe state.

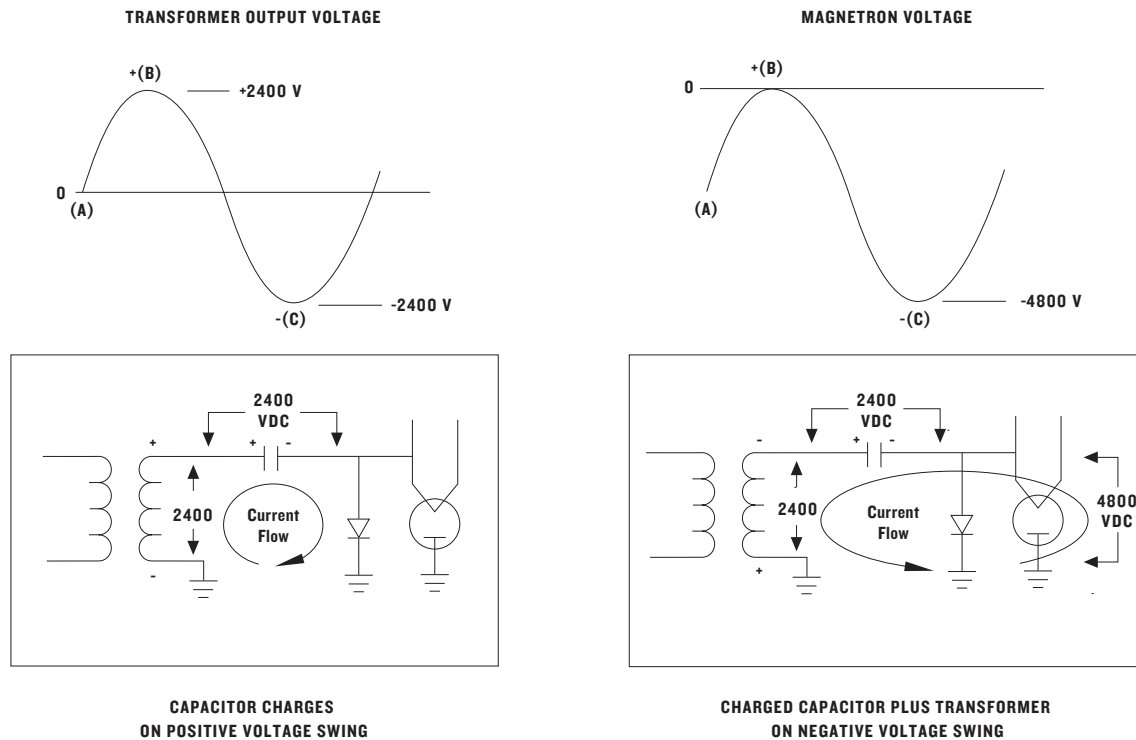

FIGURE 19: Voltage Doubler Circuit Theory of Operation

VOLTAGE DOUBLER THEORY OF OPERATION

Figure 19

1. The high-voltage transformer steps up the input voltage to approximately 2400 volts peak (4800 volts peak to peak).
2. The high-voltage capacitor charges to 2400 volts on the positive going voltage via the high voltage diode's conduction.
3. The high-voltage transformer plus the charged high-voltage capacitor supply down to -4800 volts to the magnetron when the voltage goes negative. (high-voltage diode is back biased.)
4. The magnetron converts negative input voltage (and current) to RF energy at 2450 MHz.



WARNING: Do not attempt to measure these voltages.

MICROWAVE SYSTEM PARTS

Figures 20 and 21

11. [NGC-3062-1](#) HV Transformer (2 per oven, 1 per kit) - USA, Mexico, Brazil, S. Korea
- [NGC-3062-2](#) HV Transformer (2 per oven, 1 per kit) - Europe, Asia, Pacific, Australia, UK, Ireland
- [NGC-3062-3](#) HV Transformer (2 per oven, 1 per kit) - Japan
12. [NGC-3020](#) High Voltage Capacitor (2 per oven, 1 per kit) - USA, Mexico, Brazil, S. Korea
- [NGC-3020-2](#) High Voltage Capacitor (2 per oven, 1 per kit) - Europe, Asia, Pacific, Australia, UK, Ireland, Japan 50 Hz
- [100207](#) High Voltage Capacitor (2 per oven, 1 per kit) - Japan 60 Hz

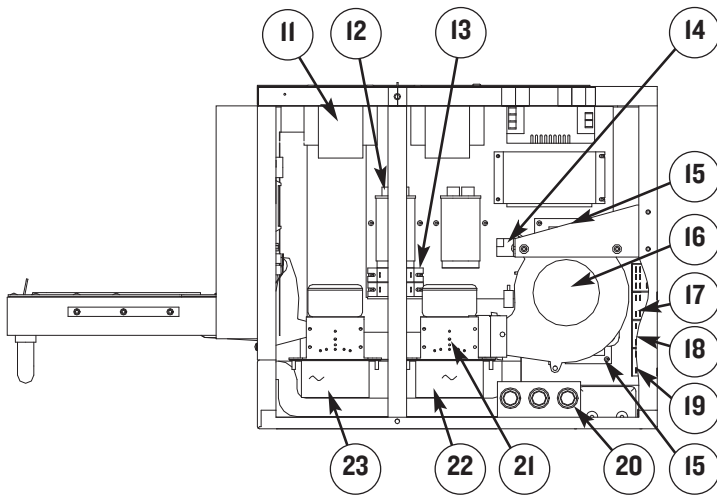

FIGURE 20: Microwave System Parts

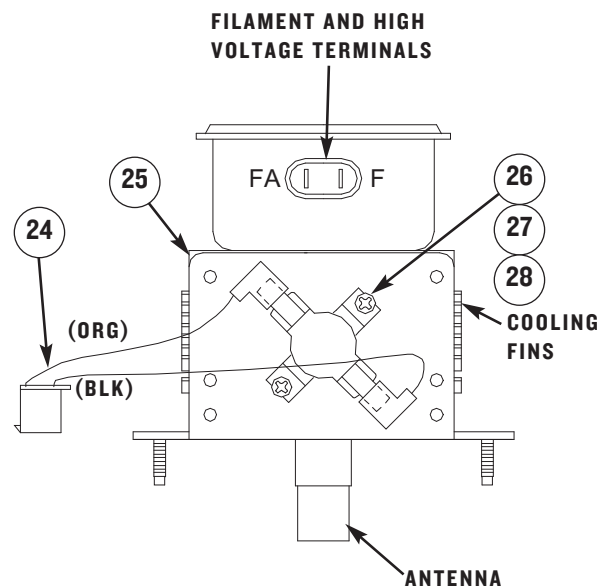

FIGURE 21: Microwave System Parts

- | | | | |
|----------------------------|--|----------------|--|
| 13. 100481 | High Voltage Diode (x2) | | |
| 14. Mag Fan Relay, Generic | | | |
| NGC-3030-1 | North America | | |
| NGC-3030-4 | Europe, Asia-Pacific Multiphase | | |
| NGC-3030-7 | Europe Single Phase | | |
| NGC-3030-12 | Brazil Single Phase | | |
| | Mag Fan Relay, SWY | | |
| NGC-3030-2 | North America | | |
| NGC-3030-6 | Europe, Brazil Single Phase | | |
| NGC-3030-9 | Europe, Asia-Pacific Multiphase | | |
| | Mag Fan Relay, SBK | | |
| NGC-3030-3 | North America | | |
| NGC-3030-13 | Europe, Brazil Single Phase | | |
| NGC-3030-14 | Indiana/North Carolina | | |
| NGC-3030-15 | Europe, Asia-Pacific Multiphase | | |
| | Mag Fan Relay, Additional* | | |
| 15. NGC-3061-1 | Filament Transformer (2 per oven, 1 per kit) - USA, S. Korea | 15. Continued: | |
| | | NGC-3061-2 | Filament Transformer (2 per oven, 1 per kit) - Europe, Asia, Pacific, Australia, UK, Ireland, Mexico, Brazil |
| | | NGC-3061-3 | Filament Transformer (2 per oven, 1 per kit) - Japan |
| | | 16. 100083 | Mag Cooling Fan |
| | | 17. 101273 | K3 Monitor Relay |
| | | 18. 101273 | K2 High Voltage Relay |
| | | 19. 101273 | K1 Filament Relay |
| | | 20. 100599 | F3 Fuse - 20 Amp |
| | | 21. NGC-3015 | Magnetron (2 per oven, 1 per kit) |
| | | 22. NGC-3017 | Wave Guide (Rear) |
| | | 23. NGC-3016 | Wave Guide (Front) |
| | | 24. 100186 | Magnetron Wire |
| | | 25. NGC-3015 | Magnetron (2 per oven, 1 per kit) |
| | | 26. 102070 | Magnetron Thermostat |
| | | 27. NGC-1163 | Insulator, Adhesive |
| | | 28. 100684 | Screw #6 Sheet Metal |

* See Comprehensive Part List, page 79.

MICROWAVE SYSTEM COMPONENTS

Below is a description of each component within the Microwave System.

Magnetron

Magnetrons supply the RF energy at 2.45 GHz and begin to oscillate when they are supplied with approximately 4.1KVDC at approximately .350 mA. During operation each magnetron will output a nominal 1 kW of power.

High-Voltage Transformers

High-voltage transformers are a ferro-resonant design which limits fault currents and minimizes magnetron power changes due to input voltage changes. The high-voltage transformer supplies the high voltage for the Voltage Doubler Circuit. They are controlled via the K2 relay.

 **WARNING:** Never attempt to measure the voltage values of the high-voltage transformers with the high-voltage transformers enabled. Lethal voltage will be present. Reference page 30 for proper measuring technique.

Filament Transformers

For better operation and reliability, the oven uses separate transformers in order to preheat the magnetron filament.

The control energizes the filament transformers for approximately five (5) seconds prior to energizing the Microwave Circuit via the high-voltage transformers. When in operation, the filament transformers supply approximately 3.15 VAC at 10 amps to each magnetron filament. The filament transformers are controlled via the K1 relay.

F3 Fuse

The F3 fuse is a 20-amp, class CC fuse designed to blow in case of an over-current scenario, such as a high-voltage transformer or capacitor failure. The fuse also blows if the Monitor Circuit trips the failsafe.

High Voltage Capacitors

Capacitor rating is 0.91uF, 2500 VDC for USA, Mexico, Brazil, and S. Korea.

Capacitor rating is 1.15 uF, 2500 VDC for Europe, Asia, Pacific, Australia, UK, Ireland, and Japan 50 Hz.

Capacitor rating is 0.85 uF, 2500 VDC for Japan 60 Hz.

High Voltage Diodes

Rated at 16 kVDC.

Monitor Relay (K3)

The monitor relay, K3, acts as a failsafe device in the Voltage Doubler Circuit. In its normal un-energized position, the monitor relay shorts L1 and L2. If the K2 relay energizes the high-voltage transformers while the K3 relay is un-energized, the F3 fuse will blow.

Magnetron Thermostats

The magnetron thermostats are open-on-rise thermostats. These thermostats are designed to open at 212°F (100°C), which triggers an F5 fault.

NOTE: Both magnetron thermostats are wired in series. If one opens, the control will switch off both magnetrons until the thermostats close. The thermostats are self-resetting.

Magnetron Cooling Fan

The magnetron cooling fan supplies cooling air for both magnetrons. The fan operates at 208 or 240 (USA) / 230 (Intl) / 200 (Japan) / 220 (Latin America) VAC and is controlled via the K7 relay (see Item 14 on Figure 20).

If the oven does not have this relay installed, it is required that you order the relay kit through Customer Service. See page 27, item 14 for part numbers. If you are unsure which kit to order, determine the software type before contacting Customer Service.

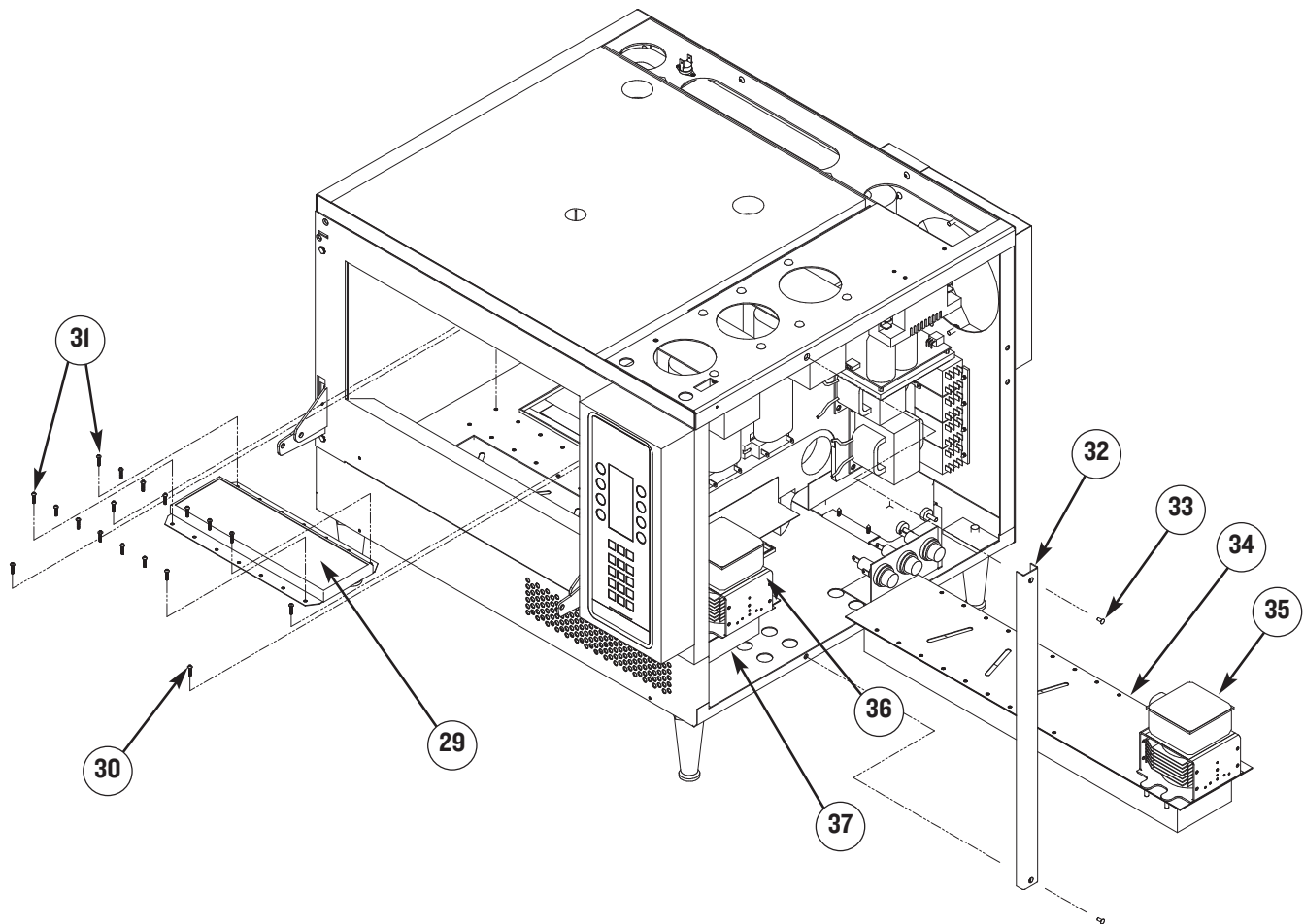

FIGURE 22: Wave Guide Cover/Wave Guide Removal and Replacement

To determine software type,

1. Make sure the oven is in the COOLING DOWN/OVEN OFF mode.
2. Simultaneously press the BACK and ENTER keys.
3. Enter code 9-4-2-8 (W-H-A-T) and press ENTER.
4. The top line on the screen will display the word TEST, followed by the software type (for example, v2SWY, or TRNADO).

WAVE GUIDE COVER REPLACEMENT

The wave guide covers keep moisture and debris out of the wave guides. If contamination gets into the wave guides, the life of the magnetrons may be shortened. Be careful to not allow debris to enter the wave guides when replacing the covers.

To remove the wave guide covers, reference Figure 22 and follow the steps below:

1. Locate the fourteen (14) #8 sheet metal screws securing the broken wave guide cover. If the screw heads are dirty, it will be necessary to clean the heads thoroughly.



CAUTION: Do not strip the screw heads.

2. Remove the fourteen (14) #8 screws. The cover should come loose with gentle pressure.

- ▣ DO NOT remove the two right and left-most screws (Item 30). These screws secure the wave guides to the oven floor. Only remove them if the wave guide is also being serviced.

3. Remove the old wave guide cover and discard, unless otherwise specified.

NOTE: It may be necessary to gently pry the wave guide covers to remove them from the oven floor as they are sealed with RTV.

4. Using acetone, clean the oven floor where the new wave guide cover will sit.
5. Apply a 1/8" diameter bead of high temperature RTV (included with Item 29) along the outside edge of the wave guide cover flanges.

NOTE: It is important to use the correct high temperature RTV as supplied by TurboChef.

6. Place the new wave guide cover in place. Secure with the fourteen (14) screws provided with Item 29.
7. Wait 15 minutes for RTV to cure.
8. Warm oven to set temperature and re-check the tightness of screws. Tighten if necessary.

 WARNING: Inside of oven and IR element are HOT! Use extreme caution during step 8.

WAVE GUIDE/WAVE GUIDE COVER PARTS

Figure 22

- | | |
|------------------------------|--|
| 29. NGC-3036 | Kit, Wave Guide Cover (Includes Item 31 and sealant) |
| 30. 101666 | Screws, #8-32 x 1/2, Cap |
| 31. 101701 | Screws, #8, SST |
| 32. NGC-1047 | Support, Frame |
| 33. 102809 | Screws, #8-32 x 3/8" CSK (100°) |
| 34. NGC-3017 | Assy, Wave Guide, Rear |
| 35. NGC-3015 | Magnetron, Rear |
| 36. NGC-3015 | Magnetron, Front |
| 37. NGC-3016 | Assy, Wave Guide, Front |

WAVE GUIDE REPLACEMENT

1. Remove the wave guide cover. See WAVE GUIDE COVER REPLACEMENT on page 29.
2. Remove the right side panel and frame support (Item 32).
3. If replacing the front wave guide, use the NGC-3016 kit. If replacing the rear wave guide, use the [NGC-3017](#) kit.

4. Remove the two (2) right and left-most screws (Item 30) that secure the wave guide to the oven floor.
5. The wave guide should now be loose enough to easily slide out from the right side of the oven.

NOTE: Be careful to not damage the insulation when removing the wave guide.

6. Install the new wave guide using the mounting screws provided with the kit (Item 34 if rear wave guide, Item 37 if front).

 CAUTION: Do not pinch insulation between the wave guide and oven bottom.

7. Reinstall the wave guide cover.
8. Reinstall the side panel and apply power to the oven.

HIGH VOLTAGE AND FILAMENT TRANSFORMER REPLACEMENT

Wiring the High-Voltage Transformers

The proper reinstallation of the high-voltage and filament transformers is critical. Upon removing a high-voltage transformer, make sure to note where each wire was installed. Refer to the oven schematics (pages 55-63) detailing the proper wiring. Specifically, T1 and T2 are located in the top-right corner of the schematics.

As shown in the schematics, transformers are installed mirror opposite and wired 180° out-of-phase. It is essential for longevity that the high-voltage transformers remain 180° out-of-phase. This can be checked by placing a volt meter across terminals T1-1 and T2-1.

With the Microwave System energized, the volt meter will read the incoming voltage (different readings for different countries). If the meter reads 0 VAC, the

high-voltage transformers are most likely wired in-phase. As a last check, energize the Microwave System and verify the voltages between the taps on each high-voltage transformer. The wiring issue must be corrected prior to returning the oven to service, as the voltages must be:

- NORTH AMERICA: 208 VAC between 1 & 2 and 240 between 1 & 3.
- LATIN AMERICA: 220 VAC
- JAPAN: 200 VAC
- INTERNATIONAL: 230 VAC

NOTE: The terminals with the orange dot or the orange wire always go to terminal 3 on USA models.

Wiring the Filament Transformers

The installation of filament transformers is straightforward. Filament transformers are wired in-phase and in-line. Refer to the schematics on pages 55-63, detailing the proper wiring. Specifically, FT1 and FT2 are located in the middle-far right edge of the schematics.

To verify correct wiring (North America), measure the voltages between terminals 1 & 2 and 1 & 3 on FT1 and FT2. The voltages must be 208 and 240 VAC respectively.

NOTE: The terminals with the orange dot or the orange wire always go to Terminal 3 on US models.

To verify correct wiring (International), measure the voltage between the taps on FT1 and FT2. The voltage must be 220 VAC (Latin America), 200 VAC (Japan), or 230 VAC (International).

MEASURING RF LEAKAGE FOR MICROWAVE SAFETY

An RF (microwave) leakage test must be performed at the conclusion of the following service tasks:

- Door removal, replacement and/or adjustment
- Wave guide removal and/or replacement
- Magnetron removal and/or replacement

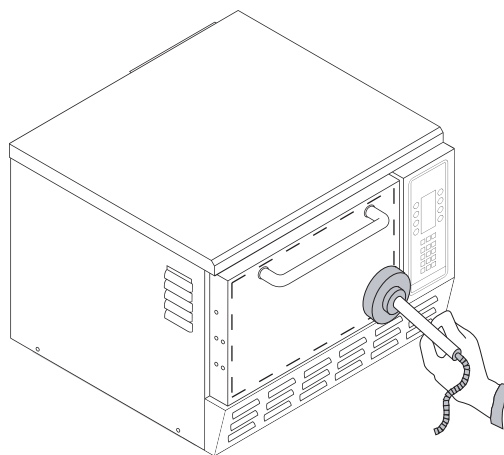

FIGURE 23: Microwave Survey Meter Placement

WARNING: If the unit fails the radiation test (leakage greater than 4 mW/cm²), the oven must be taken out of service immediately until the defect is corrected. In addition, the CDRH Regulations 21 Subpart C, 1002.20 requires that leakage readings of over 4 mW/cm² must be reported to the manufacturer.

Procedure for Measuring RF Leakage

1. Place the oven in WARM UP and allow it to warm up to the set temperature (CCSP). This should take approximately 13 minutes if the oven is starting out cold.
2. Once the oven has warmed up, place the oven into TEST MODE (see page 14). Place a water load into the cook cavity. Water load must conform to the following specification:
 - a. Volume: 275ml ± 15ml
 - b. Temperature: 68 ± 9°F (20 ± 5°C)
 - c. Vessel: Low form, 600 ml beaker with an inside diameter of approximately 3.35" (85 mm) and made of Pyrex or glass ceramic.
3. Position the microwave survey meter as shown in Figure 23.
4. Press and hold the MGTRON soft key to energize the Microwave System.

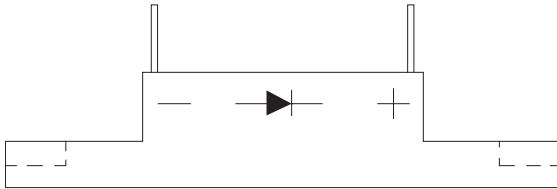

FIGURE 24: High Voltage Diode

5. While holding the MGTRON soft key, move the survey meter around the outline of the oven door, keeping the tip of the meter in contact with and perpendicular to the oven door. Record the highest leakage.
6. Using the same procedure, measure the leakage with the oven door opened to the point just before the primary and secondary switches disengage. Record the highest leakage.

TIP: To hold the oven door open for this test, back out the top center screw around the perimeter of the oven door. Continue backing this screw out until the primary and secondary interlock switches disengage. As this point, tighten the screw until both switches re-engage.

7. Using the same procedure, measure the leakage around the oven's entire exterior surface. Record the highest leakage.

HOW TO TEST MICROWAVE COMPONENTS

Testing the High-Voltage Diode

The high-voltage diode (Figure 24) is assembled by connecting several 1000-1500 volt semiconductor diodes in a series to increase the reverse voltage capability. In the circuit, the high-voltage diode conducts to prevent the filament voltage from becoming positive, thus as the high-voltage winding of the trans-

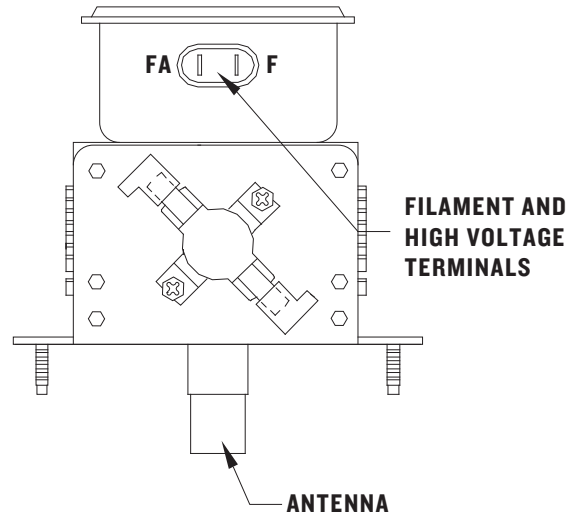

FIGURE 25: Magnetron

former goes to 2400 VPK, the high-voltage capacitor is charged to 2400 volts. When the high-voltage winding starts to go toward negative, the high-voltage diode becomes non-conducting with the charged high-voltage capacitor in series with the high-voltage winding. When the transformer gets to its negative peak of -2400 VPK, the voltage applied to the filament is negative 4500 volts.



WARNING: Never attempt to measure high voltage directly.

How to Check a Diode

1. Disconnect the oven from the power source.
2. Fully discharge the capacitors.
3. Connect the voltage meter in series with the diode.
4. Using a multimeter set to DC voltage, connect one meter lead to one side of a 9-volt battery and the other lead to one side of the diode.
5. Connect the other side of the 9-volt battery to the other side of the diode. DC voltage should only be present on the meter in one direction.
6. Switch the meter leads on the diode, which will cause the opposite reading to be visible. Depending on the voltage of the battery, voltage between 5-7 VDC should be present in only one direction and 0-0.1 VDC in the other direction.

How to Check a Capacitor

1. Disconnect the oven from the power source.
2. Fully discharge the capacitor.
3. Isolate the capacitor from the circuit.
4. Connect the ohmmeter between the capacitor terminals. The ohmmeter should momentarily indicate a low impedance and then slowly return to infinite resistance.
5. Reverse the ohmmeter leads and repeat Step 4.
6. Check each terminal to case. Infinite resistance (open) should be indicated.

How to Check a Magnetron for Open/Shorted Filament

1. Disconnect the AC power source and discharge the high-voltage capacitors.
2. Isolate the magnetron from the circuit by removing the wires from the F and FA terminals. Figure 25.

3. An ohmmeter connected between the filament terminals (F, FA) should indicate a reading of less than 1 ohm. Figure 25.
4. A continuity check between either filament terminal and the magnetron chassis should indicate an infinite resistance (open).



How to Check a High-Voltage or Filament Transformer

1. Disconnect the AC power source and discharge the high-voltage capacitors.
2. Disconnect all the wires in question going to the transformer.
3. Use an ohmmeter to check the impedance of the primary and secondary winding. Refer to the high-voltage and filament transformer table below to determine if the transformer is OK. If the resistance is different then the table indicates, replace the transformer.

HIGH VOLTAGE AND FILAMENT TRANSFORMER RESISTANCE TABLE

| HIGH VOLTAGE TRANSFORMERS | PRIMARY VOLTAGE, FREQ, TAPS, AND RESISTANCE | SECONDARY TAPS AND RESISTANCE |
|---------------------------|--|---|
| NGC-3062-1 | 208 VAC, 60 Hz, 1 & 2, 0.819–1.001 Ω 240 VAC, 60 Hz, 1 & 3, 0.972–1.188 Ω | 4, Ground, 53.60–65.52 Ω |
| NGC-3062-2 | 230 VAC, 50 Hz, 1 & 2, 0.972–1.188 Ω | 3, Ground, 57.52–70.30 Ω |
| NGC-3062-3 | 200 VAC, 50/60 Hz, 1 & 2, 0.784–0.958 Ω | 3, Ground, 55.75–68.13 Ω |
| FILAMENT TRANSFORMERS | PRIMARY VOLTAGE, FREQ, TAPS, AND RESISTANCE | SECONDARY TAPS AND RESISTANCE |
| NGC-3061-1 | 208 VAC, 60 Hz, 1 & 2, 17.49–21.37 Ω 240 VAC, 60 Hz, 1 & 3, 20.61–25.19 Ω | 4, 5, very low resistance - if reading is open, transformer has failed. |
| NGC-3061-2 | 230 VAC, 50 Hz, 1 & 2, 18.99–23.21 Ω | 3, 4, very low resistance - if reading is open, transformer has failed. |
| NGC-3061-3 | 200 VAC, 50/60 Hz, 1 & 2, 15.70–19.18 Ω | 3, 4, very low resistance - if reading is open, transformer has failed. |

MICROWAVE SYSTEM TROUBLESHOOTING

| ISSUE | RESOLUTION |
|--------------------------------------|---|
| Magnetron Troubleshooting Guidelines | <p> WARNING: Never test the secondary voltages. Voltage on this side of the circuit is lethal, reaching up to 5000 volts!</p> <p>All tests performed on the components are done with the oven unplugged and the capacitors discharged.</p> <p>The capacitors in this oven utilize a device that will automatically discharge the voltage.</p> <p> WARNING: Always verify the capacitor is discharged before servicing the components.</p> <p>Discharging can be done by unplugging the oven and then short across the red wire on each capacitor to the chassis with an insulated screwdriver.</p> |
| F3: Magnetron Current Low | <ol style="list-style-type: none"> 1. Remove the top and right side covers. 2. Enter the test mode. (From the OVEN OFF mode, simultaneously press BACK and ENTER keys, enter the code 9-4-2-8 and press ENTER). 3. Place amp meter on the brown (US ovens) or blue (International ovens) "ct" wire for amp reading. Wire is coming from the primary side of the HV transformers and looping through the black plastic current transformer on the main control board and back to the HV transformers. 4. Press and hold the MGTRON soft key on the keypad to energize the magnetrons. 5. Observe the amperage on the meter. Typical readings are: <ul style="list-style-type: none"> □ NORTH AMERICA: 12-14 amps at 240VAC/13-16 amps at 208VAC. □ INTERNATIONAL: 12-15 amps at 230VAC □ BRAZIL: 12-15 amps at 220VAC □ JAPAN: 16-17 amps at 200VAC <p>If proper amperage appears but takes longer than 2 complete seconds to appear, call TurboChef Tech support for assistance. If amperage is present but lower than typical readings, perform the troubleshooting steps in the previous pages of this section. If amperage is not present, check the condition of the F3 fuse. Fuse must be a 20-amp fuse and is the right-most of the three fuses on the bottom of the oven.</p> <p>If fuse has failed, replace the fuse after troubleshooting (previous pages of this section). If fuse has not failed, check the incoming (primary side) voltage to the high-voltage transformers.</p> |

| ISSUE | RESOLUTION |
|--|---|
| <p>F3: Magnetron Current Low (cont.)</p> | <p> WARNING: Never try to check the secondary voltages of the High Voltage Transformers.</p> <p>With the top cover removed, safe access to the three (if US oven)/two (if International oven) terminals on the top of the transformers is available.</p> <p>NORTH AMERICA - Place the AC voltmeter across terminals 1+3. Press and hold the MGTRON soft key. Voltage present should be 240 +/- 10%.</p> <p>INTERNATIONAL - Place the AC voltmeter across terminals 1+2. Press and hold the MGTRON soft key. Voltage present should be 230 +/- 10%.</p> <p>JAPAN - Place the AC voltmeter across terminals 1+2. Press and hold the MGTRON soft key. Voltage present should be 200 +/- 10%.</p> <p>If voltage is present on both high-voltage transformers, perform the component troubleshooting steps in the previous pages of this section.</p> <p>If voltage is not present, check for 24VDC control voltage from I/O board to the K2 relay. Access voltage reading from the "QC3" connection located at the bottom right side of the wiring harness. When the MGTRON key is pressed and held, 24VDC should be present on pins 1+5. Reference the schematics (pages 55-63) for physical location of pins on QC3 connector.</p> <p>If voltage is present at the connector, inspect the K2 relay and the wiring. Unplug the oven and replace relay if necessary.</p> <p>If voltage is not present at connector, check wiring connections at the control board on the 40-pin connector. Also check the wiring between the two connectors. Unplug the oven and replace control board if necessary.</p> |
| <p>F3 Fuse Blown</p> | <p>Replace the F3 fuse and determine why F3 fuse opened.</p> <p>Generally, the F3 fuse opens for one of three reasons:</p> <ol style="list-style-type: none"> HV transformer primary winding shorted: Unplug the oven and replace the HV transformer. Follow troubleshooting on page 33 to determine cause of failure. HV capacitor shorted or failing: follow troubleshooting on page 33. If necessary, unplug the oven and replace the HV capacitor. <p>NOTE: A failing HV capacitor will typically cause the HV transformer that supplies power to the failing capacitor to draw excessive current, which may open the F3 fuse.</p> |

| ISSUE | RESOLUTION |
|---|--|
| F3 Fuse Blown, cont. | <p>c. Monitor circuit fault: Verify operation of all interlock switches. In addition, check the Fault Log. If the monitor switch opened prior to the primary and secondary, the control would have recorded the occurrence. See page 25 as well as Chapter 6 (Oven Door) for troubleshooting (see F4 MONITOR).</p> |
| Mag 1 or Mag 2 Not Working or Food Not Cooking Evenly | <p>Determine which magnetron is not oscillating by placing a clamp-on amp meter on the primary winding of each high-voltage transformer and energizing the Microwave System.</p> <ol style="list-style-type: none"> 1. Amp = 0. High-voltage transformer not energizing. <ul style="list-style-type: none"> Check K2 relay and wiring going to suspect high-voltage transformer. <ul style="list-style-type: none"> □ K2 relay or wiring bad: Replace K2 relay and/or repair wiring. □ K2 relay OK: Check high-voltage transformer. See the table on page 33 for resistance values. Unplug the oven and replace high-voltage transformer if defective. 2. Amps = 3 amps on high-voltage transformer. Magnetron is not oscillating, but high-voltage transformer is energizing. <ul style="list-style-type: none"> □ Diodes failed: Unplug the oven and replace the diodes. □ Diodes OK: Unplug the oven and replace the defective magnetron. |
| Magnetron Circuit is Drawing Excessive Current. | <p>Measure resistance of high-voltage capacitor(s). Resistance should start out in the megohm range and continue to rise as the probes are held on the capacitor. If the resistance is low (less than the megohm range), unplug the oven and replace the capacitor. Visually check the associated high-voltage transformer primary winding for signs of overheating (winding is very dark and discolored). If transformer primary winding looks bad, replace it.</p> |
| High Voltage and/or Filament Transformer(s) Faulty | <p>Determine if the high-voltage or filament transformer(s) is defective. Use an ohm meter to measure the primary and secondary winding resistances. Refer to the high-voltage and filament transformer table on page 33 to determine if the transformer is OK. If the resistance is different than the table indicates, ensure the oven is unplugged and replace the transformer.</p> |
| Wave Guide Covers Broken | <p>Replace the wave guide covers. Follow the instructions on pages 29-30 and Figure 22 on page 29. Inspect the wave guides for debris. If debris is present, replace the wave guide and the magnetron.</p> |

The Oven Door

The proper fit and adjustment of the oven door is essential for safe and reliable operation of the NGC (Tornado) oven.

The oven door provides three primary functions:

1. To protect the operator from the hot convection airflow.
2. To protect the operator from exposure to microwave energy.
3. To actuate the interlock switches.

REMOVING/REINSTALLING THE OVEN DOOR

To remove or reinstall the oven door, follow the steps below. Refer to Figure 26.

1. Ensure the oven has cooled.
2. Open the oven door to its full open position. Locate the two (2) thru holes in the bottom of the left and right hinge assemblies. Insert a screw or nail into the holes to keep the hinges open while removing the oven door.

3. Locate and remove the #38 screws (3 each side).

4. Remove the plastic caps.

NOTE: The 10x32 screws do not need to be removed, as they are used for adjusting the door.

5. Remove the oven door by pulling the door away from the oven. It will slide off the hinges.

OVEN DOOR PARTS

Figure 26

- | | |
|--------------|-------------------------------|
| 38. 102809 | #8-32 x 3/8" PFH CSK |
| 39. NGC-3067 | Assy, Oven Door (Traditional) |
| NGC-3067-2 | Assy, Oven Door (SBK) |
| 40. NGC-1061 | Hinge Block |
| 41. 102804 | Right Hinge |
| 42. 102805 | Left Hinge |
| 43. 101381 | #10-32 x 1/2" Hex SS |
| 44. 102140 | #10 Flat |
| 45. 102350 | #10 Split Lock |
| 46. 101191 | Cap, Hole |

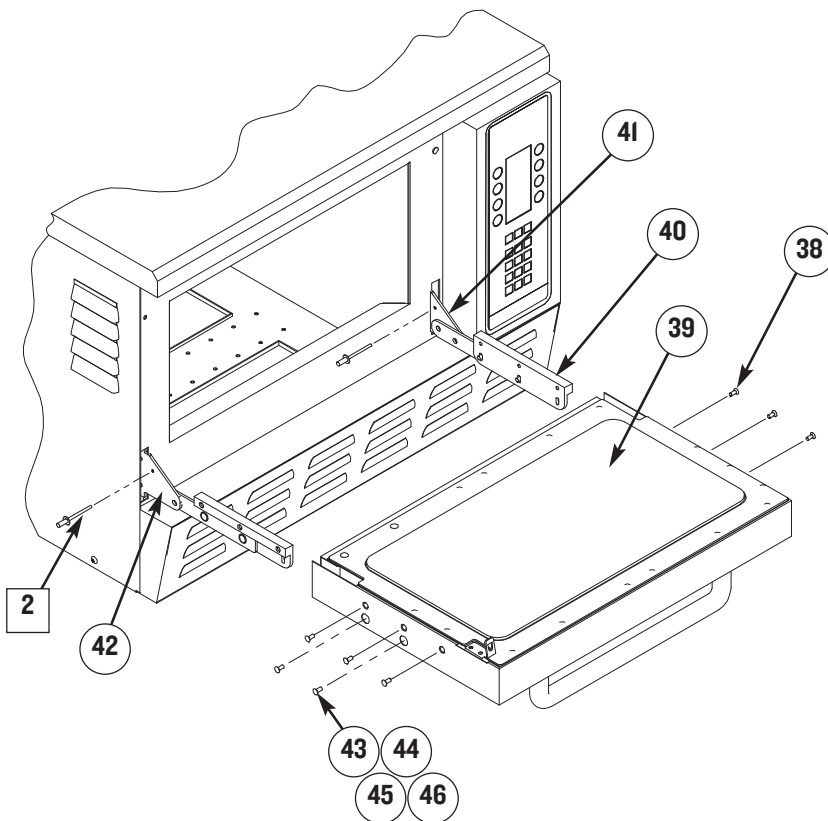

FIGURE 26: Oven Door Removal & Parts

ADJUSTING THE OVEN DOOR

WARNING: Procedure should be done while oven is hot. As a result, exercise extreme caution when adjusting the door.

1. Open the oven door and remove the plastic caps.
2. Ensure that the 3 screws on each side of the door are tight.
3. Remove the control panel, two $1\frac{1}{32}$ " nuts and wiring from I/O board.
4. Loosen the hex screws and close the door.
5. Tap the center of the door to allow door and frame to align properly.
6. Tighten screws and reinstall the control panel.
7. Plug in the oven and perform a MW leak test (see page 31 for instructions).

Critical Adjustment Notes

1. The doors in Figures 27 and 28 are adjusted incorrectly. Note how the bottom (Figure 27) and top (Figure 28) of the door can be rotated away from the Flange.

CORRECTIVE ACTION: Loosen the hex screws and push the door towards the flange and re-tighten. The hinge springs will naturally pull the door to the flange. Tapping the center ensures a level surface and a proper seal, as opposed to pushing one end (which could cause the opposite end to lift away from the flange).

Pull the door open only 0.25" (6 mm) and let go of the handle. **The door must completely snap shut on its own.** If the door sticks and force is needed to finish closing it, it is out of adjustment.

NOTE: See Figure 26, page 37, Items 43-46 for illustration of hardware.



WARNING: Check for excessive Microwave Leakage after adjusting the Cook Door. See page 31 for proper procedure.

PREPARING THE OVEN FOR SWITCH ADJUSTMENT

1. Disconnect the power to the oven and remove left and right side covers.
2. Ensure oven door assembly is properly adjusted and all mounting screws are secured (see previous section on adjusting the oven door).
3. Ensure the left and right hinge assemblies are properly mounted to the oven flange.

Oven Burn-In Procedure

If the oven is already at its set temperature at the time of service, skip this procedure.

1. Apply power to oven.
2. Simultaneously press the BACK and ENTER keys.
3. Enter 8-6-4-8 (U-N-I-T), then press ENTER.
4. Press BURN-IN. The oven will warm up and idle for 25 minutes.

ADJUSTING THE PRIMARY AND SECONDARY INTERLOCK SWITCHES - OLD SWITCH SETUP

The old switch assembly is identifiable by the primary and secondary interlock switches being located on the left side of the oven. Also, the serial number of the oven will follow the formatting below (X = variable digit/letter):

NGC-XXXXX (North America)
NGCXX-XXXXX (International)

To properly adjust the switches, follow the procedure below:

1. Ensure the oven door is adjusted properly. Refer to the previous section on adjusting the oven door.
2. Unplug the oven.

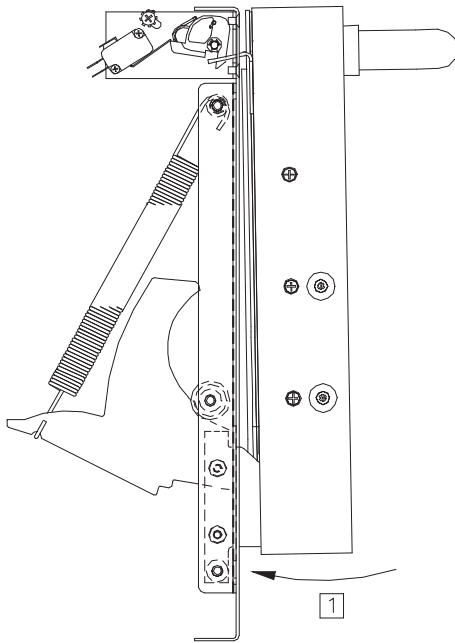

FIGURE 27: Mis-adjusted Oven Door

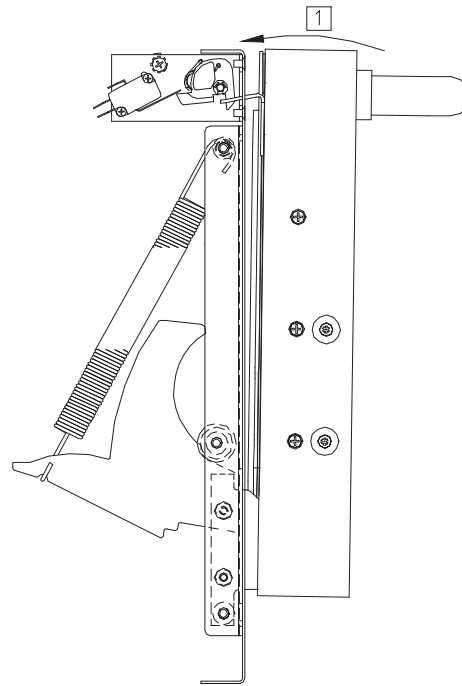

FIGURE 28: Mis-adjusted Oven Door

3. Open and close the door several times to ensure it closes smoothly and the door actuator (Item 47) clears the slot in the flange. Reference Figure 29. The actuator must not hang or rub the opening or flange. Carefully bend to clear opening.
4. While the oven door is closed, verify that the bottom of the toggle is 85° to the bottom of the frame (Figure 29). If not, use items 75 and 76 (page 42) to achieve proper angle.
5. Temporarily adjust the primary and secondary interlock switches by loosening the #8-32 screw (Item 49) and the two (2) #4-40 screws (Item 50). Figure 29.
6. Rotate the interlock switches (Item 51) until the gap between the switch paddles and the switch body is 0.02" (0.5mm). Figure 29.
7. Restore power to the oven. Allow the oven to warm to its set temperature.
8. Allow the oven to remain at the set temperature for ten (10) minutes after warm up before making any final adjustments, which may be needed because the door can move as a result of temperature change.
9. Securely tighten Items 49 and 50 after any final adjustments have been made.
10. Complete the steps for measuring RF leakage found on page 31. Make further adjustments if necessary.

NOTE: High-temperature grease (Item 62) must be present between the torsion spring and the switch bracket assembly to ensure smooth action.

PRIMARY AND SECONDARY INTERLOCK SWITCH ADJUSTMENTS AND PARTS

Figure 29

| | |
|--------------------------------|------------------------------|
| 47. NGC-1076-2 | Actuator, Door |
| 48. 102809 | Screw, #8-32 x 3/8" 100P CSK |
| 49. 102921 | Screw, #8-32 x 3/8" |
| 50. 101557 | Screw, #4-40 x 1 1/4" |
| 51. 102012 | Interlock Switches |
| 52. NGC-3033 | Assy, Door Switch* |

*See Figure 30 for assembly detail.

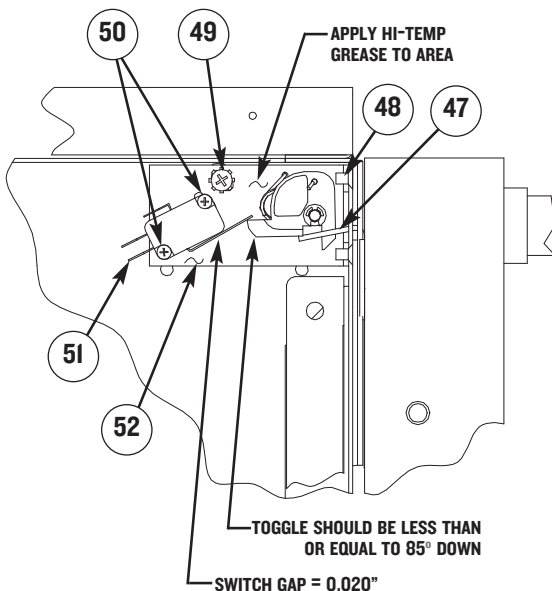

FIGURE 29: Correct Primary and Secondary Interlock Adjustment and Parts - Old Switch Setup

DOOR SWITCH ASSEMBLY AND PARTS

Figure 30, next page

- 53. [NGC-1072](#) Bracket Latch
- 54. [102012](#) Switch, Micro, 0.1A/125VAC
- 55. [NGC-1087](#) Spring Door Latch
- 56. [NGC-1073](#) Toggle, Latch
- 57. [101119](#) Pin, Clevis, $\varnothing 3/16$ x 1" Lg
- 58. [100059](#) Bearings, Bronze, $3/16$ ID x $5/16$ OD x $1/4$ " Lg
- 59. [101557](#) Screw, #4-40 x 1.25" Lg, PPHD, CRES
- 60. [102921](#) Screw, #8-32 x $3/8$ ", Internal Tooth Sems, PPHD, SS
- 61. [NGC-1126](#) Plate, Door Switch
- 62. [NGC-3006](#) Grease, USDA H-1, Food Grade
- 63. [101296](#) Ring, E-clip

Assembly Notes

1. Ring, e-clip (Item 63) is supplied with Item 56.
2. Spring and bracket must be lubricated with high-temperature pure FM grease (Item 62).
3. Assembly must be hand-tightened prior to any final adjustment.

ADJUSTING THE MONITOR SWITCH - OLD SETUP

The old switch assembly is identifiable by the monitor switch being located on the right hinge assembly. Also, the serial number of the oven will follow this formatting (X = variable digit/letter):

NGC-XXXXX (North America)
 NGCXX-XXXXX (International)

To adjust the switch, follow the steps below.

1. Ensure the oven door is adjusted. Refer to ADJUSTING THE COOK DOOR on page 38.
2. Turn on oven and bring it to the set temperature.



WARNING: Oven surfaces are HOT! Use extreme caution when making adjustments.

3. Open and close the oven door several times to ensure the door closes smoothly and the door actuator (Item 47) clears the slot in the flange. Reference Figure 29.
4. Disconnect oven from power source.
5. To adjust the monitor safety switch (Figure 31), loosen the #8-32 screw and the two (2) #4-40 screws (Items 68 and 69) securing the switch.
6. Rotate the monitor safety switch (Item 65) until the gap between the switch paddle and the switch body is 0.02" (0.5 mm).
7. Open and close the oven door several times to make certain the adjustment is correct.
8. Tighten all screws.
9. Reconnect oven to power source.
10. Allow oven to sit at the set temperature for 10 minutes and confirm all adjustments.

MONITOR SAFETY SWITCH PARTS

Figure 31, next page

- 64. [102804](#) Hinge, Right
- 65. [102012](#) Switch, Limit, Micro
- 66. [NGC-1126](#) Plate, Door Switch
- 67. [101912](#) Standoff, #8-32F/Fx1 in S
- 68. [102921](#) Screw, #8-32 x $3/8$ "
- 69. [102902](#) Screw, 4-40 x $5/8$ "

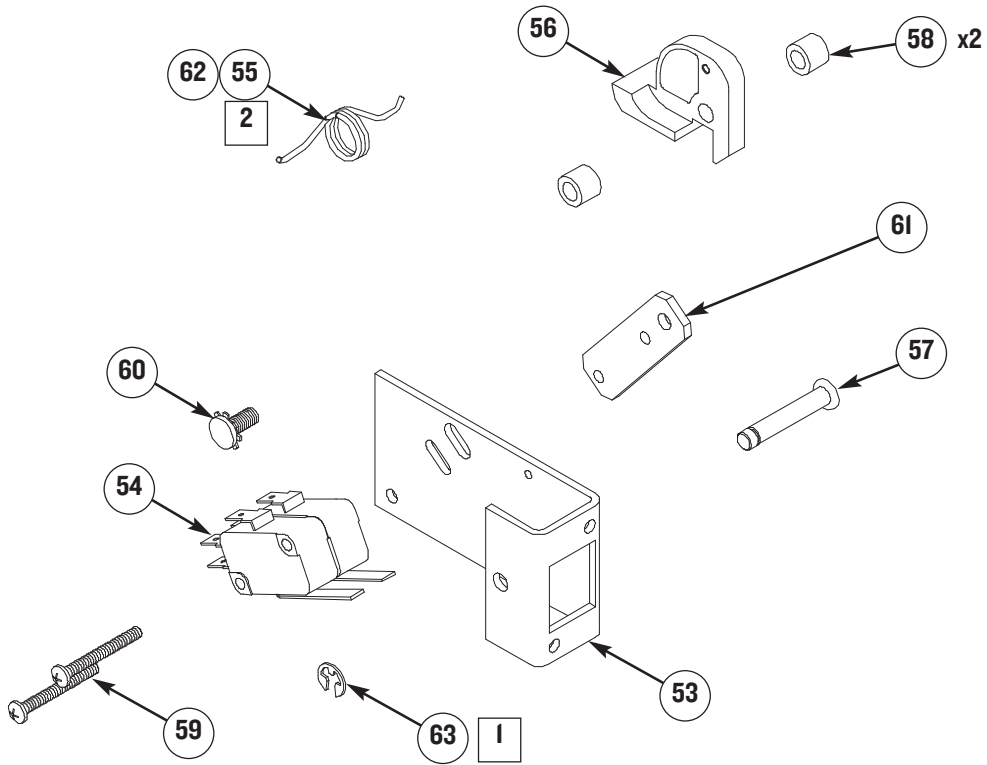

FIGURE 30: Door Switch Assembly and Parts - Old Switch Setup

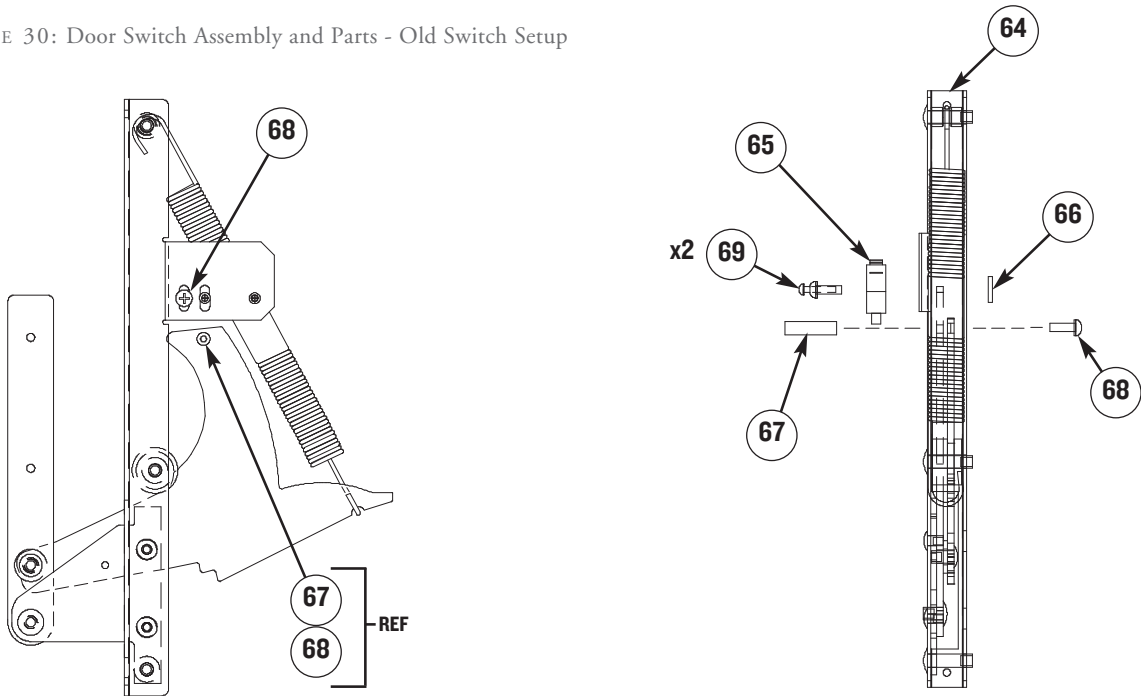

FIGURE 31: Monitor Switch Adjustment and Assembly - Old Switch Setup

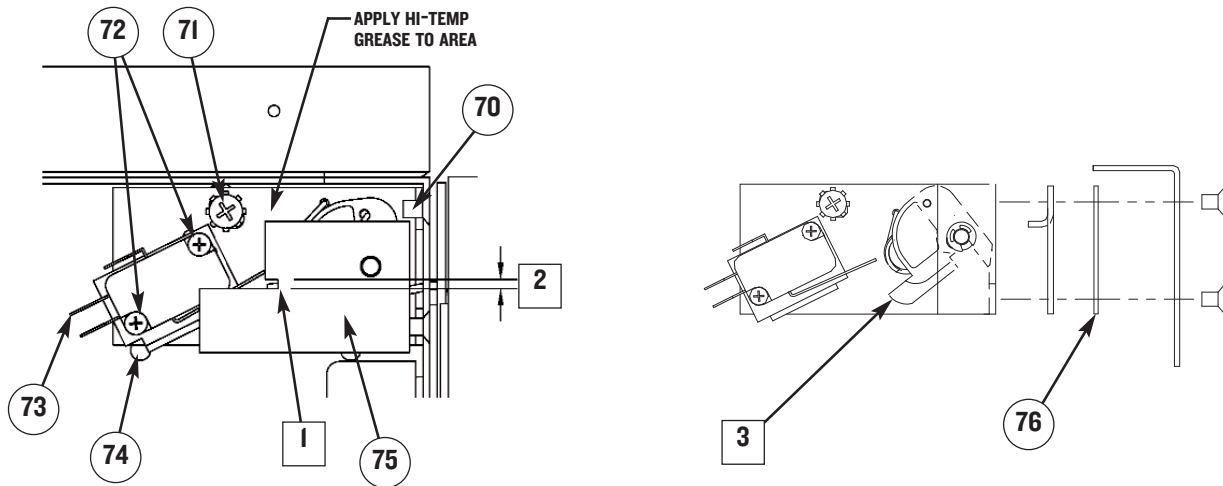

FIGURE 32: Primary Switch Adjustment and Parts -
New Switch Setup

ADJUSTING THE PRIMARY INTERLOCK SWITCH - NEW SWITCH SETUP

The new switch assembly is identifiable by the primary switch being located on the left side of the oven. Also, the serial number of the oven will follow the formatting below (X = variable digit/letter):

NGCD(5 thru 9)XXXX (North America)
NGCXXD(5 thru 9)XXXX (International)

1. When the oven completes BURN IN (if required, see page 38), closely examine the latch toggle position using the door switch gauge (Item 75).
2. If the toggle is past the top of the window, you must correct the toggle's position by installing an 0.030" Shim (Item 76). See Figure 32.
3. Verify position of toggle by opening and closing the oven door.
4. With the toggle correctly adjusted and the door closed, adjust the primary switch by loosening the two #4-40 screws and #8-32 screw.
5. Using a 0.030" (0.762 mm) spacer as a template (included with Item 74), adjust switch lever position to a maximum allowable distance of 0.030" (0.762 mm).
6. Open and close the door several times to verify the switch gap.

PRIMARY SWITCH ADJUSTMENT AND PARTS

Figure 32

| | | |
|-----|--|------------------------------|
| 70. | 102809 | Screw, #8-32 x 3/8" 100P CSK |
| 71. | 102921 | Screw, #8-32 x 3/8" |
| 72. | 101555 | Screw, #4-40 x 3/4" |
| 73. | 102012 | Interlock Switch |
| 74. | NGC-3033 | Assy, Door Switch* |
| 75. | Adjustment Tools (included with Item 74) | |
| | NGC-1215 | Door Switch Gauge |
| | NGC-1340 | Shim Tool, 0.060" |
| | NGC-1344 | Shim Tool, 0.030" |
| 76. | NGC-1169-1 | Shim, 0.030" |
| | NGC-1169-2 | Shim, 0.045" |

*Refer to FSB-10057 (included with Item 74) for instructions on converting [NGC-3033](#) kit into the new switch assembly.

Assembly Notes

1. Tip of toggle must be within window notch. Optimal is centered or below centered when the oven is hot.
2. Tip of toggle adjustment notch. Toggle must be within notch when oven is hot.
3. If toggle "hangs" in position as shown, decrease number of shims.

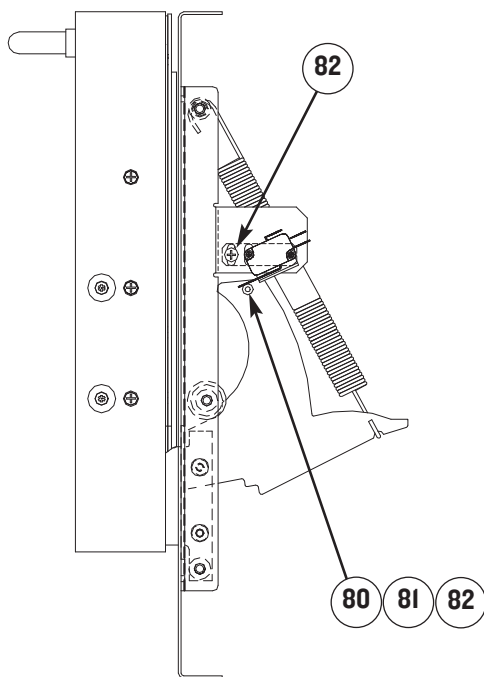

FIGURE 33: Secondary/Monitor Adjustment and Parts - New Switch Setup

ADJUSTING THE SECONDARY AND MONITOR INTERLOCK SWITCHES - NEW SWITCH SETUP

1. Disconnect power to the unit.
2. Disconnect the 40-pin connector from the I/O board to allow maximum clearance.
3. Using the 0.060" (1.524 mm) spacer as a template (included with item 74), adjust the secondary switch.

NOTE: This will also adjust the monitor switch.

4. Open and close the door several times to verify the switch gap.

NOTE: The absolute maximum gap should not exceed 0.060" (1.524 mm).

5. Re-connect the 40-Pin connector to the I/O board and apply power to the unit.
6. Simultaneously press BACK and ENTER keys.
7. Enter 9-4-2-8, then press ENTER.
8. Open the oven door and verify P, S, and M

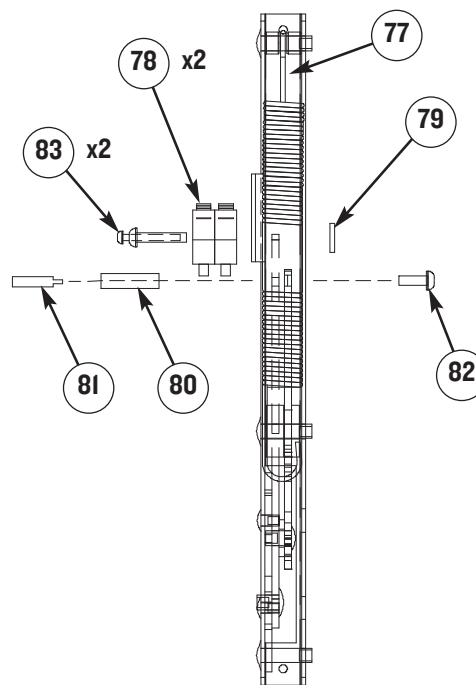

FIGURE 34: Secondary/Monitor Switch Assembly - New Switch Setup

disengage in sequence.

9. Close the oven door and verify the M, S, and P engage in sequence.
10. Energize the Microwave System and open the door.
11. Verify the W indicator is backlit, meaning the oven microwave system turns OFF when the door is open.

SECONDARY AND MONITOR SAFETY SWITCH PARTS

Figure 33 and 34

- | | |
|--------------|---|
| 77. 102804 | Hinge, Right |
| 78. 102012 | Switch, Limit, Micro (x2) |
| 79. NGC-1126 | Plate, Door Switch |
| 80. 101914 | Standoff, #8-32 F/F x 1", 5/16" DIA |
| 81. 101915 | Standoff, #8-32 M/F x 5/16", 1/4" DIA (attached to outside of Item 80.) |
| 82. 102921 | Screw, #8-32 x 3/8" |
| 83. 101558 | Screw, 4-40 x 1.125" |

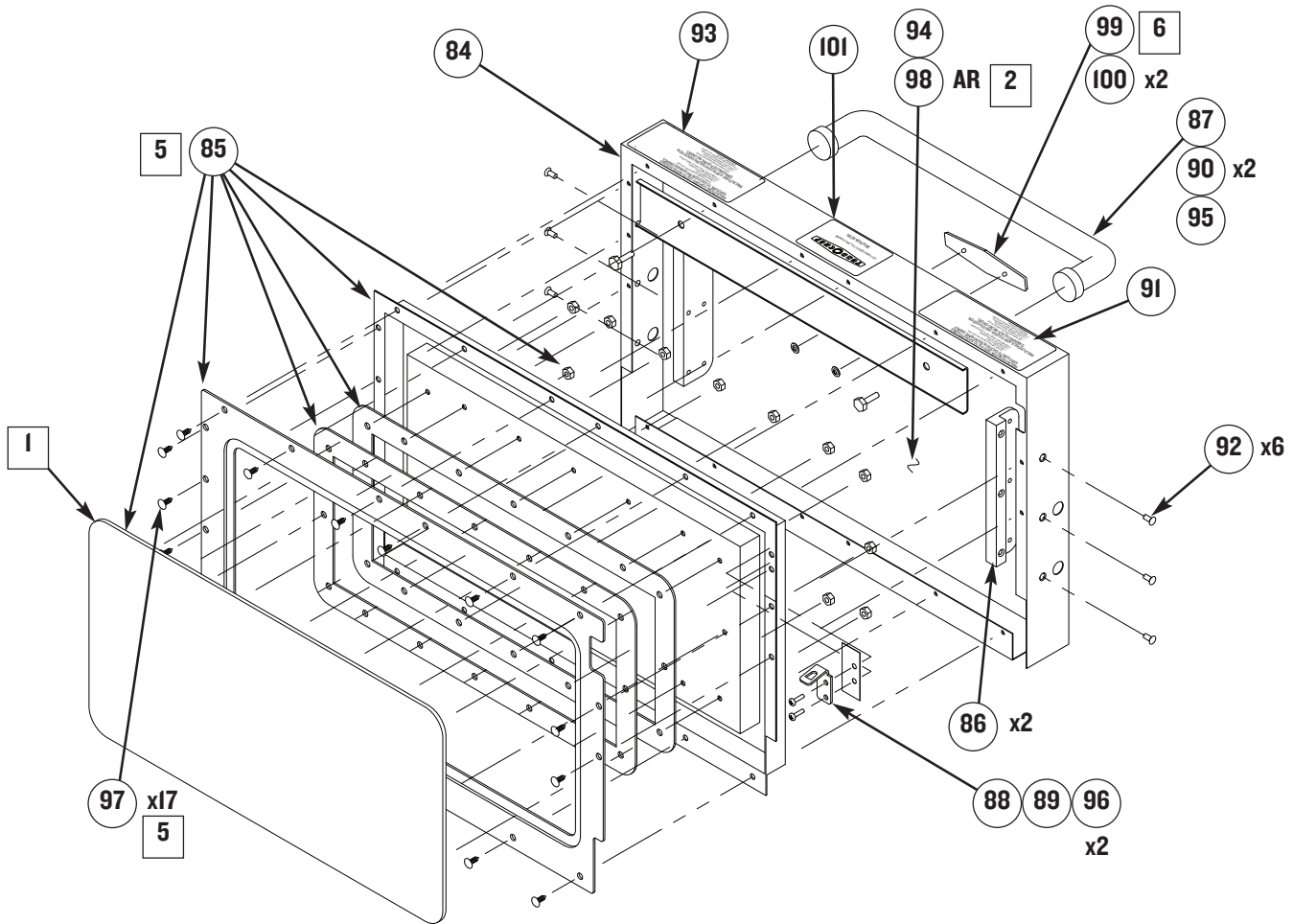

FIGURE 35: Oven Door Assembly

OVEN DOOR ASSEMBLY

See Figure 35 above. For mis-adjustments, see Figures 27 and 28 on page 39.

OVEN DOOR PARTS

Figure 35

| | |
|--------------------------------|------------------------|
| 84. NGC-3067* | Door, NGC, Generic* |
| NGC-3067-2* | Door, NGC, SBK* |
| 85. NGC-3021 | Kit, Shunt Plate |
| 86. NGC-1061 | Hinge Block |
| 87. 102750 | Handle, Door, Generic |
| NGC-1216 | Handle, Door, SBK |
| 88. NGC-1076-2 | Actuator, Door |
| 89. NGC-1132 | Shim, Door Latch |
| 90. 102945 | Bolt, 1/4" - 20 x 1.00 |

| | |
|--------------------------------|---------------------------------------|
| 91. NGC-1138 | Label, Precaution |
| 92. 102809 | #8-32 x 3/8" CSK 100° |
| 93. NGC-1165 | Label, Caution Empty |
| 94. NGC-1125-1 | Door Insulation 1 |
| NGC-1125-2 | Door Insulation 2 |
| 95. NGC-1127 | Channel, Door Handle |
| 96. 102748 | Screw, #8-32 x 3/8", Torx Security |
| 97. 101688 | Screw, #8 x 1/2" PTH |
| 98. 102698 | Tape, Aluminum |
| 99. NGC-1155 | Name Plate, TurboChef |
| 100. 101293 | Nut, Push, 1/8" |
| 101. NGC-1170 | Label, Service |

* Includes items 85 - 101.

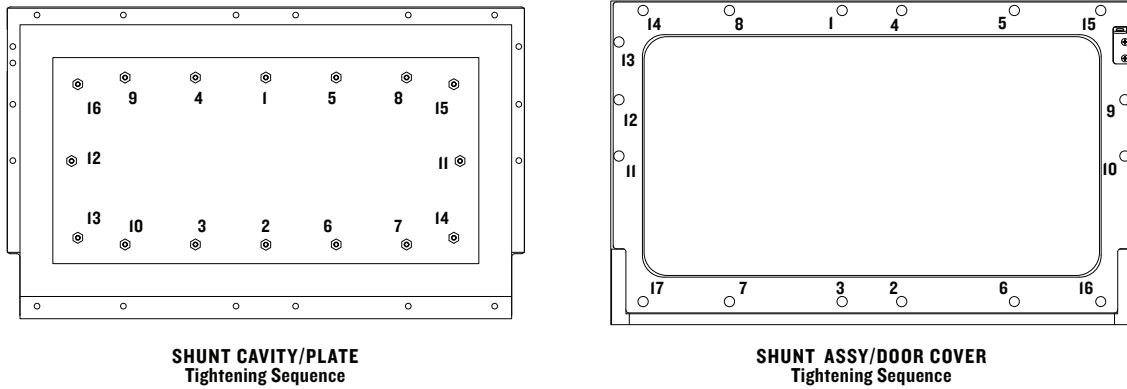

FIGURE 36: Oven Door Assembly: Tightening Specs

Critical Adjustment Notes (Figure 35)

1. Orient with the gasket seam at the bottom of the door assembly. Gasket should be straight with no twists or pinching.
2. Attach insulation (Item 94) to the inside of the door cover using aluminum tape (Item 98).
 - ▣ DO NOT block openings at bottom.
3. Item 94 (insulation) not shown for clarity.
4. Door should be flat without twisting or warpage after tightening all hardware.
5. Refer to the chart to the right for torque specs. Refer to Figure 36, above, for tightening sequences.
6. Attach Item 99 with adhesive backing using the two locating holes on the front cover.

SCREW TORQUE CHART

Refer to Figures 35, 36.

| PART | TORQUE VALUE |
|---|------------------------|
| 90. Bolt, 1/4"-20 x 1.00 | 80 In-Lbs (9.04 Nm) |
| 85. Nut, Keps #8-32 (Assembled by factory) | 21 In-Lbs (2.37 Nm) |
| 96. Screw, 8-32 x 3/8" Torx Security | 21 In-Lbs (2.37 Nm) |
| 97. Screw, 8 x 1/2" PTH | 21 In-Lbs (2.37 Nm) |

INTERLOCK SWITCH TROUBLESHOOTING

| ISSUE | RESOLUTION |
|---------------------------------|---|
| <p>“Cook Door Open” Message</p> | <p>Determine which interlock switch is open. Access TEST MODE to view interlock switch status.</p> <p>1. PSM - Primary and/or secondary interlock is open (old switch setup). PSM - Primary interlock is open (new switch setup).</p> <p>Verify action of the latch assembly and oven door. When the door closes, the actuator should freely clear the slot on the flange. When it strikes the toggle latch, it should rotate smoothly to its closed position.</p> <ul style="list-style-type: none"> □ Actuator doesn't clear slot: Bend or adjust actuator. If the actuator is worn or has yielded, replace the actuator. □ Toggle doesn't rotate freely or smoothly: Replace any worn parts. Clean assembly and re-lubricate all rotating parts. Be sure to grease the torsion spring (See Figure 30). □ Actuator and toggle OK: Check adjustment and wiring on the interlocks. If adjustment is necessary, see page 38 (old setup) or page 42 (new setup) for the proper adjustment procedure. <p>2. PSM – Monitor switch is open (old switch setup). PSM – Secondary and/or monitor switch is open (new switch setup).</p> <p>Verify that the door closes freely and completely.</p> <ul style="list-style-type: none"> □ Door does not close freely: Remove obstructions or readjust the oven door per the instructions on page 38. □ Door closes properly: Readjust the monitor safety switch (old switch setup)/secondary and monitor (new switch setup) per the instructions on page 38 (old setup) and 42 (new setup). |

The Convection Circuit

The Convection Circuit provides the high-temperature airflow required to brown and cook food items.

CONVECTION CIRCUIT COMPONENTS

The following is a description of each component within the Convection Circuit and how each acts within the circuit. Figure 37 below shows a block diagram of the Convection Circuit.

Main Convection Heater

The main convection heater is an open-coil style heater rated at 3300 watts at 208 VAC with a resistance of 13.11 Ohms. The convection heater is controlled by the K4 solid state relay.

Convection Motor

The convection motor is a brushless AC switch reluctance type. Its top speed is 7100 RPM at 1 HP. The motor is controlled by a proprietary controller.

Motor Controller (BMSC)

The motor controller is proprietary and will only operate the convection motor described above. The motor controller is controlled on command from the I/O control board and a 0-10VDC speed command from the I/O control board.

High Limit Thermostat

The high limit thermostat is a 250 VAC, 3-pole, manual reset thermostat with a trip point of 572°F (300°C). The thermostat, which interrupts power to both the main convection heater and the IR element, should never operate during normal oven operation.

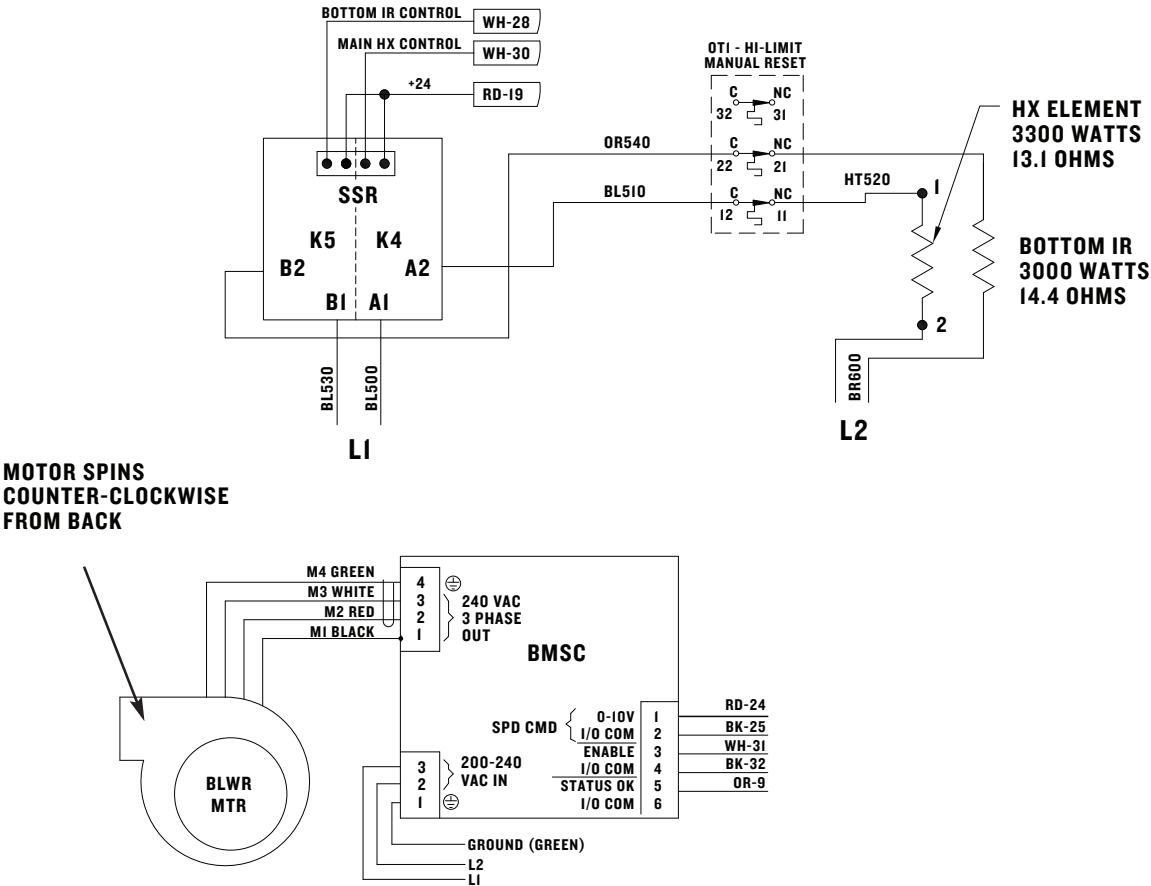

FIGURE 37: Convection Circuit Block Diagram

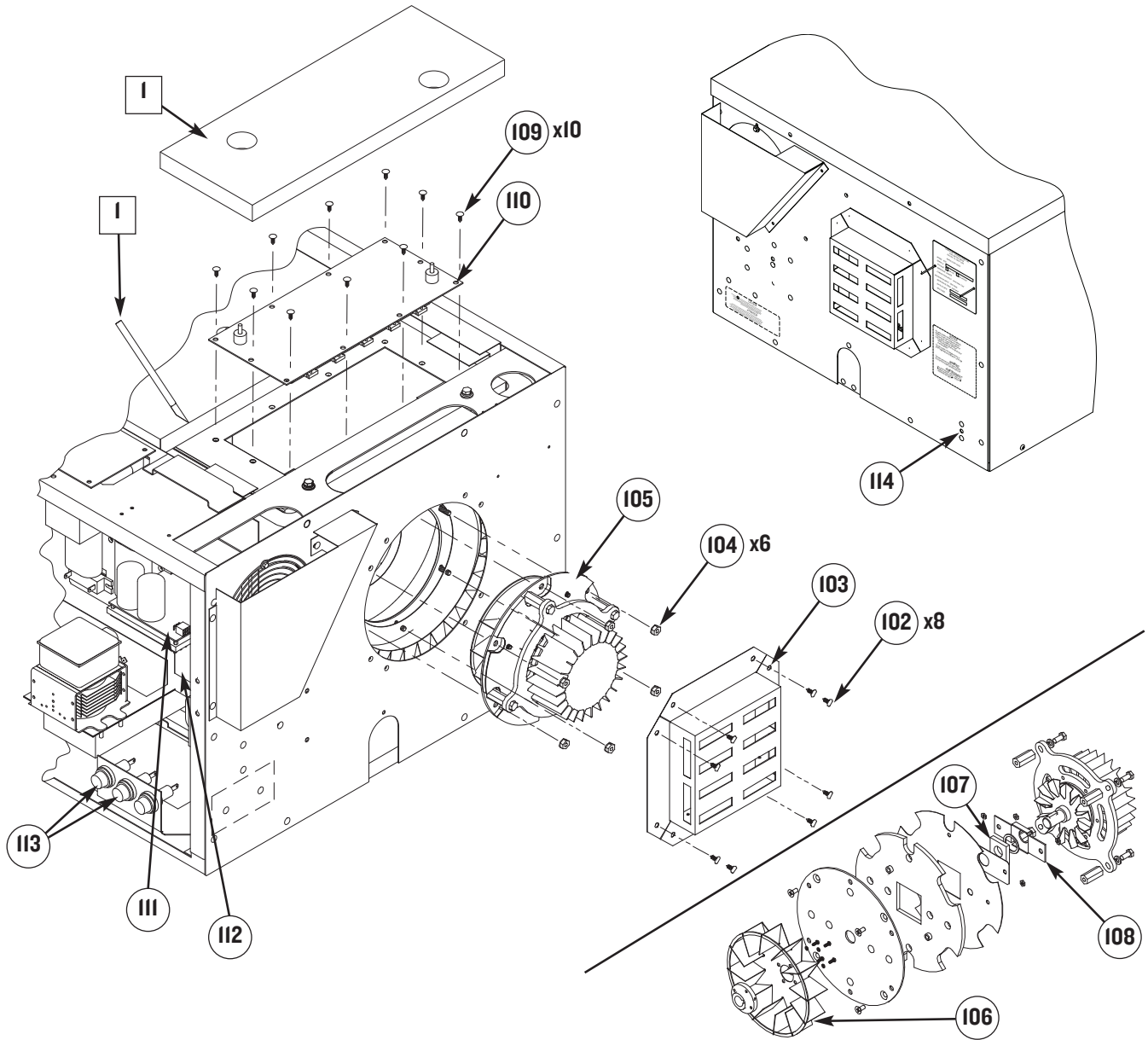

FIGURE 38: Convection Circuit Assembly and Parts/Item 105 (Blower Motor) Detail

CONVECTION CIRCUIT/BLOWER MOTOR PARTS

Figure 38

- 102. 101688 Screw, #8 x 1/2" PTH
- 103. NGC-1081 Cover, Motor
- 104. 100906 Nut, 1/4"-20, Flange
- 105. NGC-1025 Assy, Blower Motor
- * 106. NGC-3007 Kit, Fan Blade
- * 107. NGC-1024 Sealing Block, Blower
- * 108. NGC-1023 Clamp, Blower Seal
- 109. 101688 Screw, #8 x 1/2" PTH
- 110. NGC-3011 Heater, Convection
- 111. 100443 Controller, Motor

- 112. NGC-3005 Relay, K4/K5 SSR
- 113. 100592 Fuses, F1 and F2 (12 Amp)
- 114. 102075 High-Limit Thermostat
- ** 115. NGC-1043 Gasket, Convection Heater

* If entire motor is needed, order **NGC-1025**.
 If only hardware (e.g., screws, nuts) or seal is needed, call 800.90TURBO or +1 214-379-6000.

** Not shown for clarity.

Assembly Notes

- 1. Cut insulation covering heater as shown.

CONVECTION CIRCUIT TROUBLESHOOTING

| ISSUE | RESOLUTION |
|--|--|
| <p>F8: Heat Low</p> <p>Oven Not Warming Up</p> | <ol style="list-style-type: none"> 1. Check that the blower motor is moving air. <ul style="list-style-type: none"> □ Blower motor is not moving air: Check blower motor assembly and verify motor is stalled. Unplug oven and correct obstruction or replace motor. (For access to motor shaft, remove top panel.) □ Blower motor is moving air: Verify high-limit thermostat is not tripped. See the high-limit thermostat information below. <p>High-Limit Thermostat:</p> <ul style="list-style-type: none"> □ Thermostat tripped: Reset and determine why the thermostat tripped (See Figure 38, Item 114). Look for excess build up of grease inside the oven or any other source for a fire. □ Thermostat is not tripped: Check main convection heater. <ol style="list-style-type: none"> 1. Convection heater is defective: Unplug oven and replace the convection heater and verify the K4 SSR (Figure 37) is not shorted across output. 2. Convection heater OK: Check the K4 SSR. <ul style="list-style-type: none"> □ K4 defective: Unplug oven and replace. □ K4 OK: Unplug oven and verify all wiring. Verify P1 voltage on I/O board is 5.0VDC (+/- 0.02) - see Figure 40, page 54. |
| <p>F2: Cook Temperature Low</p> | <ol style="list-style-type: none"> 1. Verify Cook Door Operation. <ul style="list-style-type: none"> □ “Cook Door Open” Message: Verify which switch is not actuating and readjust. See pages 38-43. □ Cook Door OK: Verify high-limit thermostat is not tripped. See the high-limit thermostat below. <p>High-Limit Thermostat:</p> <ul style="list-style-type: none"> □ Thermostat tripped: Reset and determine why the thermostat tripped (See Figure 38, Item 114). Look for excess build up of grease inside the oven or any other source for a fire. □ Thermostat is not tripped: Check main convection heater. <ol style="list-style-type: none"> 1. Convection heater is defective: Unplug oven and replace the convection heater and verify the K4 SSR (Figure 37) is not shorted across output. 2. Convection heater OK: Check the K4 SSR. <ul style="list-style-type: none"> □ K4 defective: Unplug oven and replace. □ K4 OK: Unplug oven and verify all wiring. Verify P1 voltage on I/O board is 5.0VDC (+/- 0.02) - see Figure 40, page 54. |

| ISSUE | RESOLUTION |
|-------------------------------|--|
| F1: Blower Running Status Bad | <ol style="list-style-type: none"> 1. Verify motor spins freely. <ul style="list-style-type: none"> □ Motor seized: Unplug oven and correct obstruction or replace motor. □ Motor spins freely: Verify motor windings (see table below). 2. Verify motor windings are OK. Measure the resistance between windings and chassis. Unplug oven and replace motor if resistances do not agree with the values in the table below. If motor is OK, proceed to step 3, below. 3. Determine if status indicator “A” is highlighted/backlit in TEST MODE. <ul style="list-style-type: none"> □ “A” is highlighted/backlit. <ol style="list-style-type: none"> a. Disconnect control wiring. b. Ground OR-9 to chassis to remove backlight on “A”. c. Keeping OR-9 grounded, check terminals on the control wiring plug for 0-10 VDC control voltage (reference drawing of QC3 plug on schematics (pages 55-63) while incrementing blower speed in TEST MODE (see BLOWER SPEED, page 15). d. If DC voltage is present throughout all speed settings in TEST MODE (see BLOWER SPEED, page 15), replace motor controller. If not, check harness and/or replace I/O board. |

MOTOR WINDING RESISTANCES TABLE

| TO | FROM | DESCRIPTION | EXPECTED RESISTANCE |
|---------------------|-------|---------------------|---------------------|
| Black | Red | Winding (A-B) | 2.0 – 2.6 Ohms |
| Black | White | Winding (A-C) | 2.0 – 2.6 Ohms |
| Red | White | Winding (B-C) | 2.0 – 2.6 Ohms |
| Black, White or Red | Green | Windings to Chassis | Open |

IR Element and Catalytic Converter

The IR Element and Catalytic Converter provide two very different, but essential functions.

The IR element provides the bottom browning - similar to a residual broiler or salamander type cooking appliance - required for cooking most food items. The IR element temperature is independently controlled in each recipe.

The catalytic converter scrubs the air to eliminate VOCs and grease particulates that are liberated during the cooking process. It is important to properly care for the catalyst using only TurboChef® Oven Cleaner (P/N 103180 USA, 103380 Intl) and distilled water. For more detailed information, see the catalytic converter section below.

COMPONENTS

IR Element

The IR element - a dual coil type heater - is located in the bottom of the oven cavity. The first coil is the heating coil. The second is the IR thermocouple wire. The heating coil outputs 3000 watts at 208 VAC. The heating coil's resistance is 14.4 ohms at room temperature.

The thermocouple coil is a Type K thermocouple with a resistance of approximately 20 ohms at the splices located approximately 6 inches from the heater and 40 ohms measured at the extension wires at the I/O control board.

The IR element is controlled via the K5 solid state relay and the IR thermocouple via the I/O control board.

Catalytic Converter

The catalytic converter, a VOC type catalyst, is located behind the inside cook cavity wall and is responsible for cleaning the recirculating airflow. The catalyst functions by substantially lowering the combustion temperature of grease entrained in the air path to approximately the same temperature

of the airflow, thus the grease burns and breaks down into CO₂ and H₂O as it passes through the catalytic converter. The catalyst will operate most efficiently at temperatures above 475°F (246°C).

The catalyst material is very sensitive to certain chemical compounds. Irreversible damage can occur if the catalyst is exposed to cleaning chemicals containing phosphates, NaOH, silicates, Na and Potassium Salts. These chemicals are found in most commercial degreasers and cleaners; therefore, only TurboChef® Oven Cleaner should be used.

 **CAUTION:** Clean the catalytic converter with TurboChef® Oven Cleaner and rinse thoroughly with distilled water. Let the catalytic converter air dry before reinstalling. If TurboChef® Oven Cleaner is not available, do not use a substitute. Use distilled water only.

IR ELEMENT AND CATALYST REMOVAL

Refer to Figure 39 and the instructions below for removing the IR element and catalytic converter.

Removing the IR Element

1. Unplug the oven.
2. Disconnect the heater wires going to the EMI filter and the high-limit thermostat.
3. Locate where the IR element protrudes through the cook cavity walls and remove the snap rings (Item 116) using snap ring pliers. Retain snap rings (Item 116) and washers (Item 117). Figure 41.
4. Locate and remove the microwave shield (Item 119) by removing the four (4) #8 x 1/2" sheet metal screws (Item 120).

NOTE: Some models do not contain item 119.

5. Squeeze the IR element together inside the cook cavity and pull the IR element from the oven.

Removing and Installing the Catalytic Converter

1. Unplug the oven.
2. Remove the IR element. (See above procedure.)
3. Once the IR element has been removed, remove the catalytic converter clip (Item 121) to access the catalytic converter. Figure 39.

NOTE: It may be necessary to remove the blower motor assembly (see page 48) to get access to the top of the catalytic converter. This will allow the catalytic converter to be pushed down out of the housing. Figure 39.

4. Remove the catalytic converter (Item 122).
5. Inspect the condition of the catalytic converter and either clean it or install a new one.

! CAUTION: Clean catalytic converter using only TurboChef cleaner (P/N 103180 USA, 103380 Intl). Use of other chemicals will irreparably damage catalyst.

Installing a New IR Element

1. Unplug the oven.
2. Gently squeeze the new IR element together in order to get the terminals and lead wires into the cavity and through the mounting holes.

! CAUTION: Do not allow the thermocouple lead wires to kink. They are solid wire and will break.

3. Once the IR element is installed, expand the IR element in order to reinstall the shim washers (Item 117) and snap rings (Item 116). Figure 39.

NOTE: Be sure that the snap rings sit in the grooves on IR element.

4. Reconnect the IR element lead wires to the EMI filter and the high-limit thermostat.
5. Reconnect the IR thermocouple lead wires to the thermocouple extension wires – Yellow to Yellow and Red to Red.

IR ELEMENT AND CATALYTIC CONVERTER PARTS

Figure 39

| | | |
|---------------|-------------------------------------|---------------------------------|
| 116. 101312 | Snap Ring | |
| 117. 102449 | Washer, Shim | |
| 118. NGC-3003 | IR Element | |
| 119. NGC-1116 | Shield, Microwave | |
| 120. 101688 | Screw, #8 x 1/2" Sht Metal PTH | |
| 121. NGC-1030 | Clip, Catalytic Converter (Non-SBK) | |
| | NGC-1233 | Clip, Catalytic Converter (SBK) |
| 122. NGC-1012 | Catalytic Converter | |

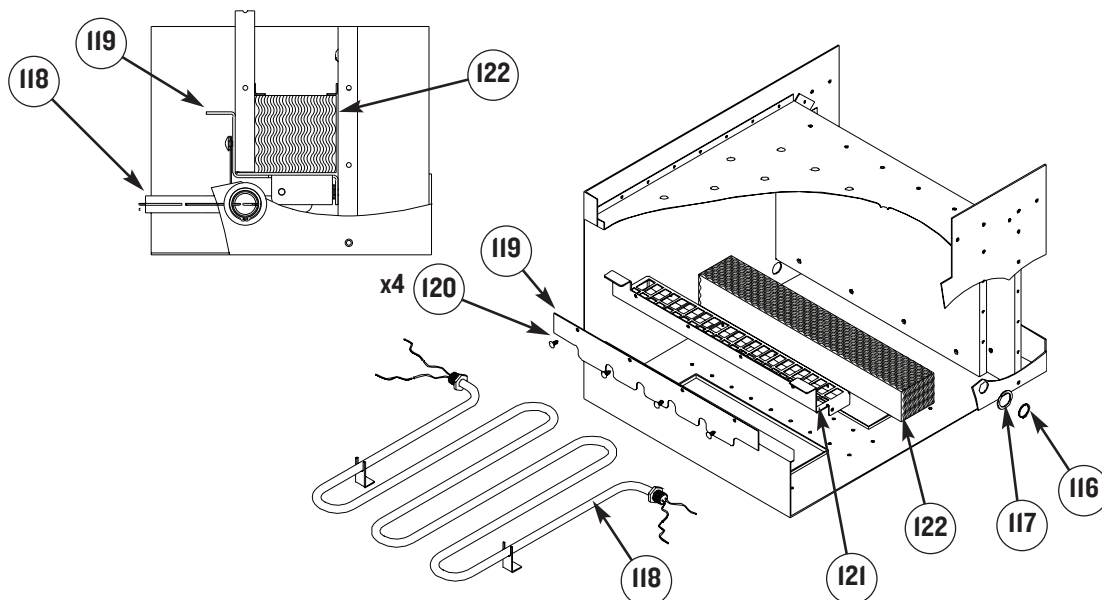

FIGURE 39: IR Element and Catalytic Converter Assembly

Schematics and Schematic Components

FIGURES 40 THRU 45: NGC OVEN SCHEMATICS

| | |
|-----------|----------------------|
| Figure 40 | I/O Board Schematic |
| Figure 41 | NGC US Schematic |
| Figure 42 | NGC UK Schematic |
| Figure 43 | NGC EW Schematic |
| Figure 44 | NGC ED Schematic |
| Figure 45 | NGC Brazil Schematic |

SCHEMATIC PARTS**Line Voltage Components**

| |
|---|
| Capacitor, High Voltage (C1) |
| Capacitor, High Voltage (C2) |
| Controller, Motor |
| Diode, High Voltage (D1) |
| Diode, High Voltage (D2) |
| EMI Filter (P/N 100542 USA, UK, Ireland, Brazil, Japan 1Ph) |
| EMI Filter (P/N 100545 Europe, Asia, Pacific, Australia, Japan 3Ph) |
| Fan 1, Cooling |
| Fan, Magnetron (Fan 1) |
| Fuse Holders, F1, F2, and F3 |
| Fuse, F1, 12 Amp |
| Fuse, F2, 12 Amp |
| Fuse, F3, 20 Amp |
| Heater, Convection |
| Heater, IR Element |
| Magnetron (M1) |
| Magnetron (M2) |
| Motor, Convection |
| Power Supply, +24VDC (PS) |
| Relay, K1, Filament |
| Relay, K2, Anode |
| Relay, K3, Monitor |
| Relay, K4/K5, Solid State, K4/K5, Heater/IR |
| Relay, K6, Voltage |
| Relay, K7, Magnetron Cooling Fan |
| Thermostat, OT2, Cooling Fan |
| Thermostat, OT1, Heater |
| Transformer, Filament (FT1) |
| Transformer, Filament (FT2) |
| Transformer, High Voltage (T1) |
| Transformer, High Voltage (T2) |
| Voltage Sensor Module (US ovens only) |

Low Voltage Components

| |
|-------------------|
| Display, VFD |
| I/O Control Board |

| |
|-----------------------------|
| Keypad, NGC Oven |
| Switch, Primary Interlock |
| Switch, Secondary Interlock |
| Switch, Monitor Safety |
| Thermocouple, CC |
| Thermocouple, EC |
| Thermostat, Magnetron |

Wire Harness Replacement P/Ns**Low Voltage Harness**

| | |
|--------------------|------------------|
| 123. 100185 | Old Switch Setup |
| NGC-1418 | New Switch Setup |

Line Voltage Harness

| | |
|------------------------|------------------------------|
| 124. NGC-1150-1 | North America |
| NGC-1150-2 | UK, Ireland, Brazil |
| NGC-1150-3 | Eu, Asia, Pacific, Au, Japan |

Magnetron Wire

| | |
|--------------------|---------------|
| 125. 100186 | All NGC Ovens |
|--------------------|---------------|

Power Cord

| | |
|--------------------|--------------------------------|
| 126. 100187 | USA |
| 100194 | NGC ED - Europe, Asia, Pacific |
| 100195 | UK, Ireland, Brazil |
| 103187 | NGC EW- Europe, Asia, Pacific |
| 103195 | Australia |
| NGC-1383 | Japan 3Ph |
| NGC-1390 | Japan 1Ph |

I/O CONTROL BOARD ITEM IDENTIFICATION AND TEST POINT LOCATIONS

| | |
|-----------|---|
| Figure 40 | |
| C9 | Capacitor |
| D6 | Diode |
| J2 | 40 Pin Connector for LV Harness |
| J3 | 3 Pin Connector for VFD Display |
| J4 | 14 Pin Connector for Keypad |
| J5 | 26 Pin Connector for Display Data |
| J6 | RS-232 Connector (Unused) |
| P1 | Voltage Reference 0-5 VDC RJ11 Connector for Smart Card Cable |
| P3 | Blower Controller Pin Configuration U15 EPROM Socket |
| R42 | Voltage Reference Adjustment (not available on some ovens) |
| R51 | Beeper Volume Adjustment |
| SKP1 | Beeper |
| U19 | Erasable EPROM Socket |
| T1 | Magnetron Current Transformer |

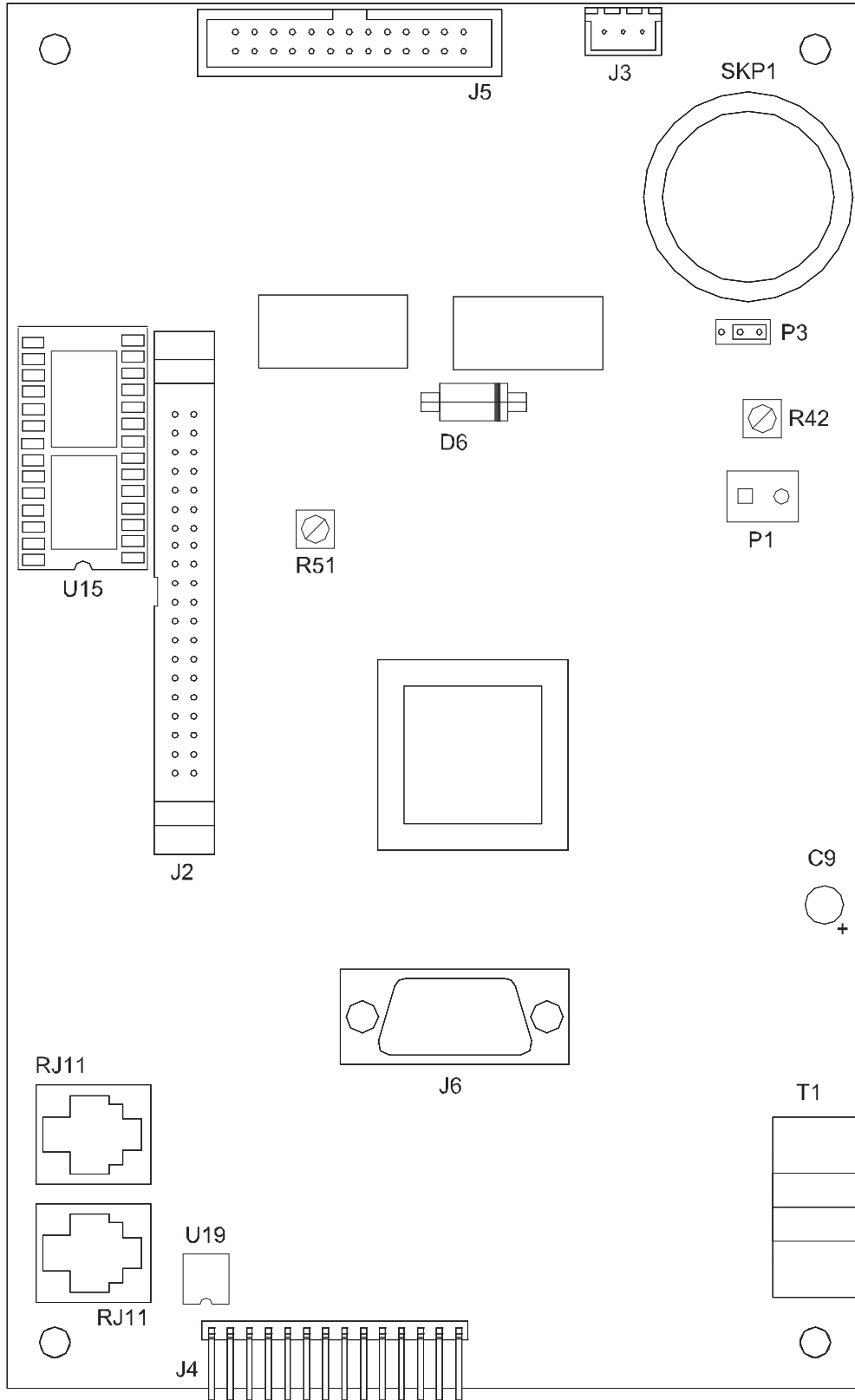

FIGURE 40: I/O Control Board and Test Point Locations

NOTES:
 1. SCHEMATIC SHOWS OVEN WITH DOOR OPEN AND WITHOUT POWER APPLIED

COLOR CODE (LINE VOLTAGE)
 BL - BLUE = LINE V (208/240)
 BR - BROWN = LINE V (208/240)
 OR = 240 LINE INPUT FOR TAP 3 ON ALL TRANSFORMERS
 BK = HI-TEMP 240 VAC WIRE

COLOR CODE (LOW/CONTROL VOLTAGE)
 BK - BLACK = 24 VDC COMMON
 OR - ORANGE = STATUS INPUT
 WH - WHITE = CONTROL OUTPUT
 RD - RED = +24VDC

COLOR CODE (HIGH VOLTAGE/TENSION)
 WH - HI-VOLTAGE WIRE FOR MAG 1
 BK - HI-VOLTAGE WIRE FOR MAG 2

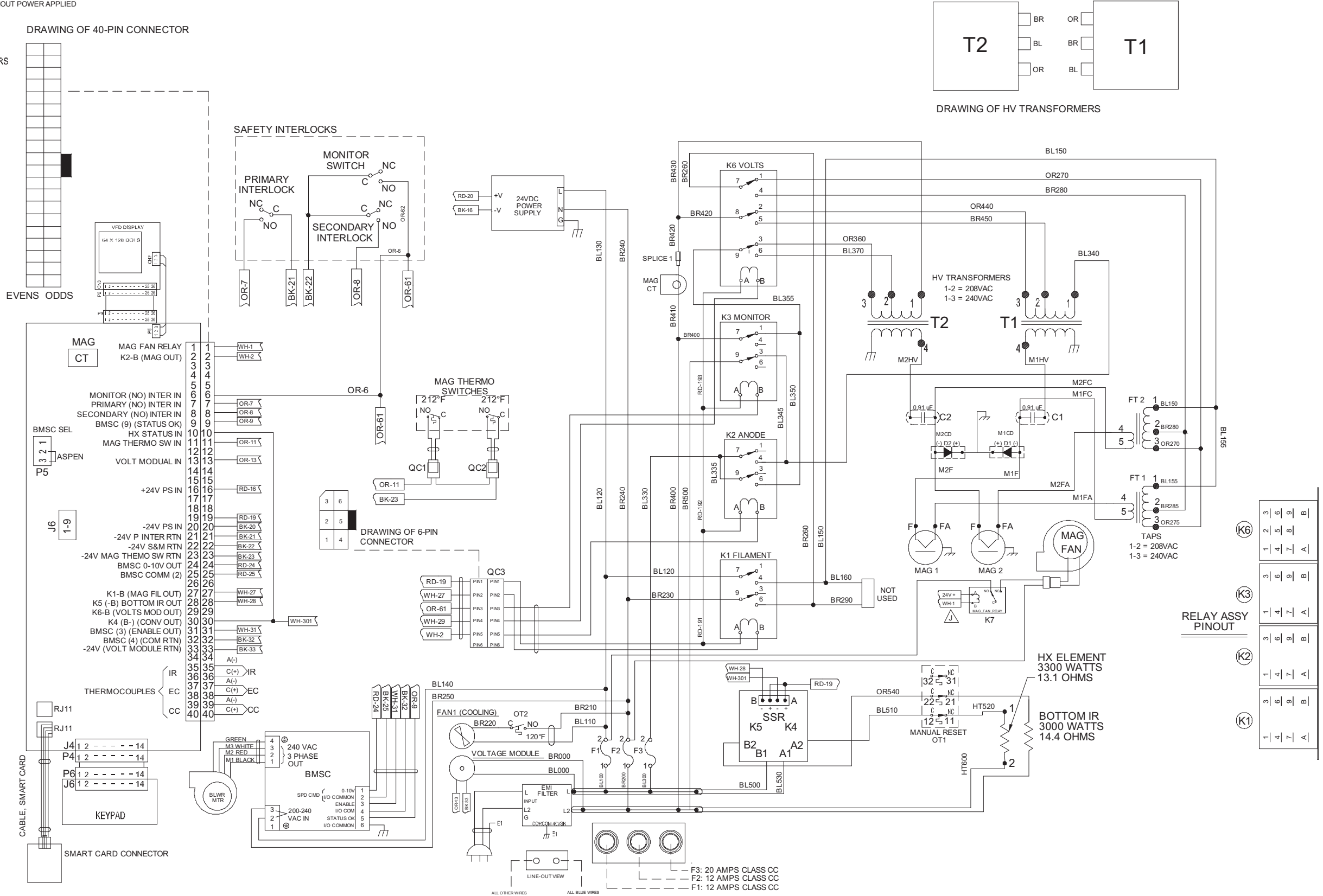

FIGURE 40: NGC (Tornado) Schematic

NOTES:

1. SCHEMATIC SHOWS OVEN WITH DOOR OPEN AND WITHOUT POWER APPLIED

COLOR CODE (LINE VOLTAGE)

BL - BLUE = NEUTRAL
 BK - BLACK = LINE V (230VAC)
 BR - BROWN = LINE V (230VAC)
 RED = RED LINE V (230VAC)
 HT = HI-TEMP (230VAC)

COLOR CODE (LOW/CONTROL VOLTAGE)

BK - BLACK = 24 VDC COMMON
 OR - ORANGE = STATUS INPUT
 WH - WHITE = CONTROL OUTPUT
 RD - RED = +24VDC

COLOR CODE (HIGH VOLTAGE/TENSION)

WH - HI-VOLTAGE WIRE FOR MAG 1
 BK - HI-VOLTAGE WIRE FOR MAG 2

DRAWING OF 40-PIN CONNECTOR

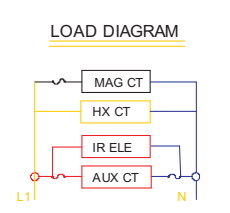
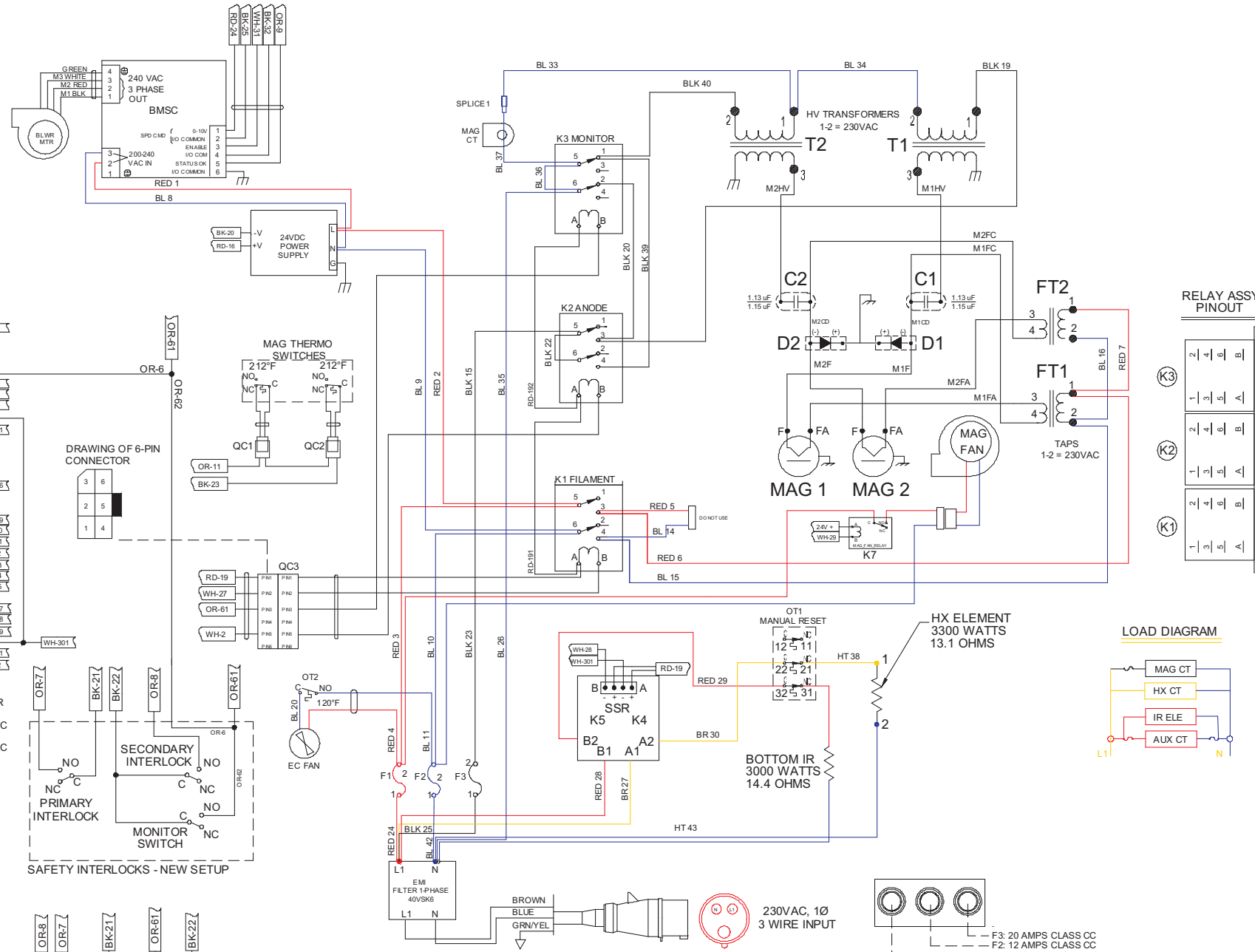
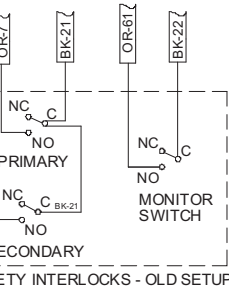
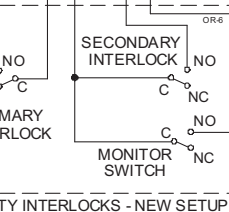
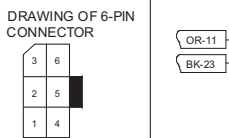
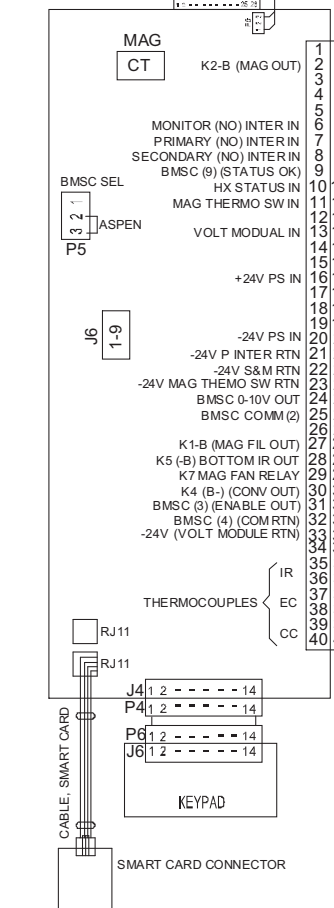
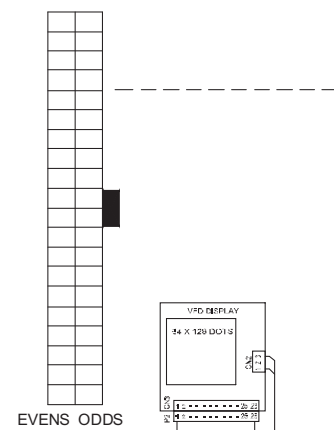

F3: 20 AMPS CLASS CC
 F2: 12 AMPS CLASS CC
 F1: 12 AMPS CLASS CC

FIGURE 41: NGCUK (Tornado) Schematic

NOTES:

1. SCHEMATIC SHOWS OVEN WITH DOOR OPEN AND WITHOUT POWER APPLIED

COLOR CODE (LINE VOLTAGE)

BL - BLUE = NEUTRAL
 BK - BLACK = LINE V (230VAC)
 BR - BROWN = LINE V (230VAC)
 RED = RED LINE V (230VAC)
 HT = HI-TEMP (230VAC)

COLOR CODE (LOW VOLTAGE/CONTROL VOLTAGE)

BK - BLACK = 24 VDC COMMON
 OR - ORANGE = STATUS INPUT
 WH - WHITE = CONTROL OUTPUT
 RD - RED = +24VDC

COLOR CODE (HIGH VOLTAGE/TENSION)

WH - HI-VOLTAGE WIRE FOR MAG 1
 BK - HI-VOLTAGE WIRE FOR MAG 2

DRAWING OF 40-PIN CONNECTOR

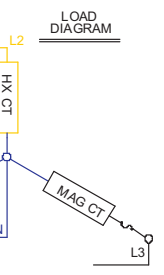
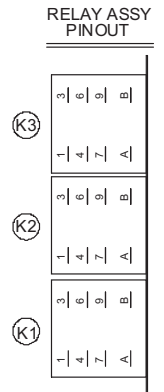
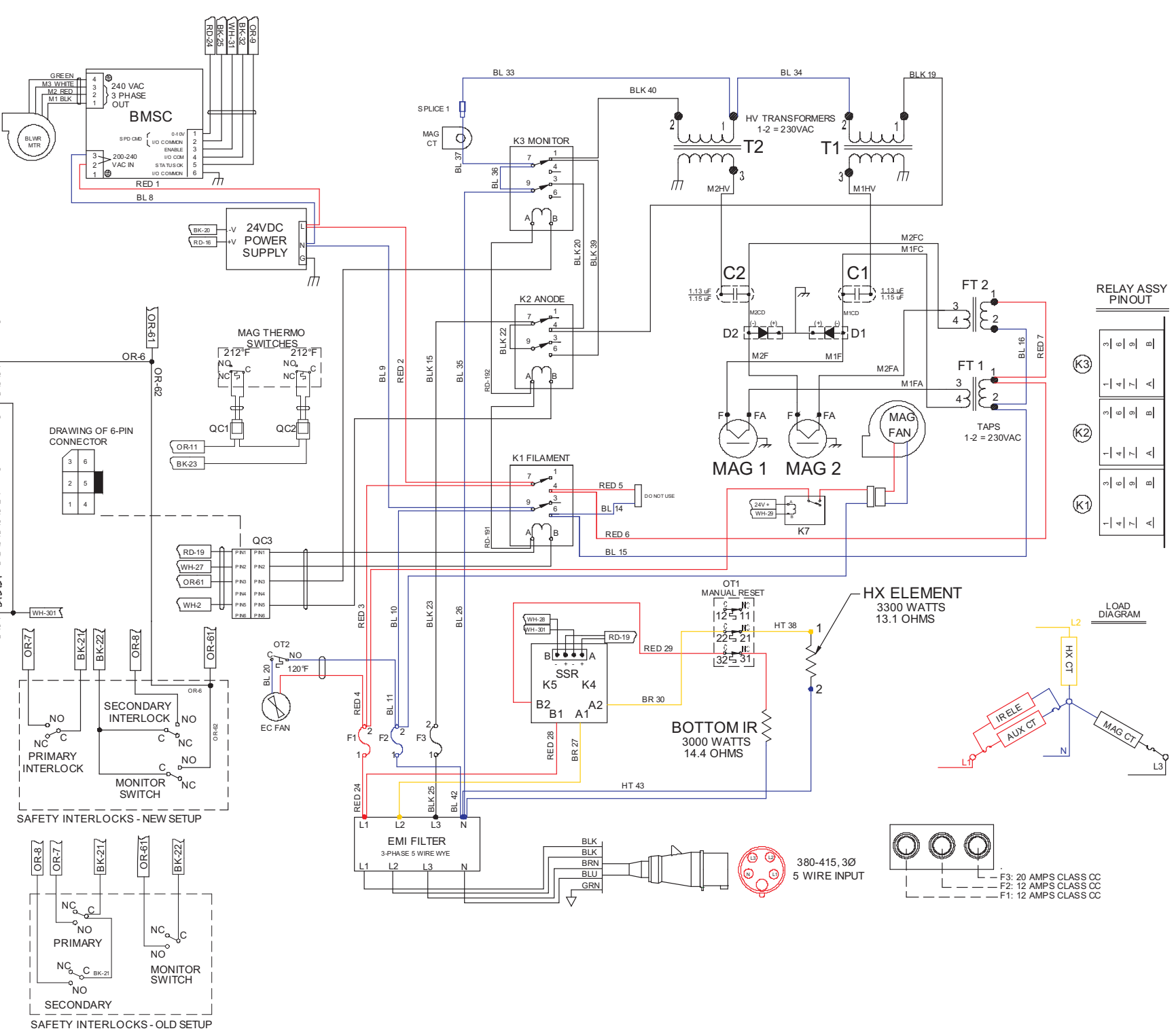
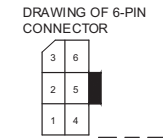
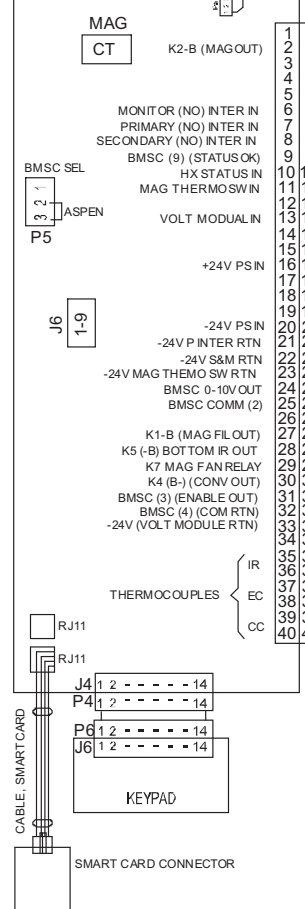
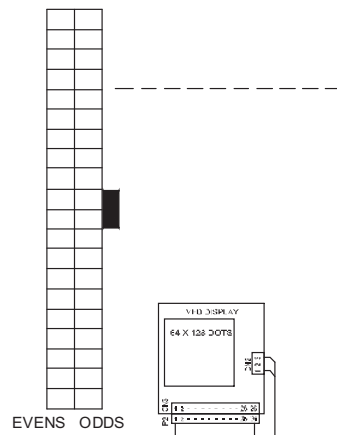

F3: 20 AMPS CLASS CC
 F2: 12 AMPS CLASS CC
 F1: 12 AMPS CLASS CC

FIGURE 42: NGCEW (Tornado) Schematic

NOTES:

1. SCHEMATIC SHOWS OVEN WITH DOOR OPEN AND WITHOUT POWER APPLIED

COLOR CODE (LINE VOLTAGE)

BL - BLUE = NEUTRAL
 BK - BLACK = LINE V (230VAC)
 BR - BROWN = LINE V (230VAC)
 RED = RED LINE V (230VAC)
 HT = HI-TEMP (230VAC)

COLOR CODE (LOW CONTROL VOLTAGE)

BK - BLACK = 24 VDC COMMON
 OR - ORANGE = STATUS INPUT
 WH - WHITE = CONTROL OUTPUT
 RD - RED = +24VDC

COLOR CODE (HIGH VOLTAGE/TENSION)

WH - HI-VOLTAGE WIRE FOR MAG 1
 BK - HI-VOLTAGE WIRE FOR MAG 2

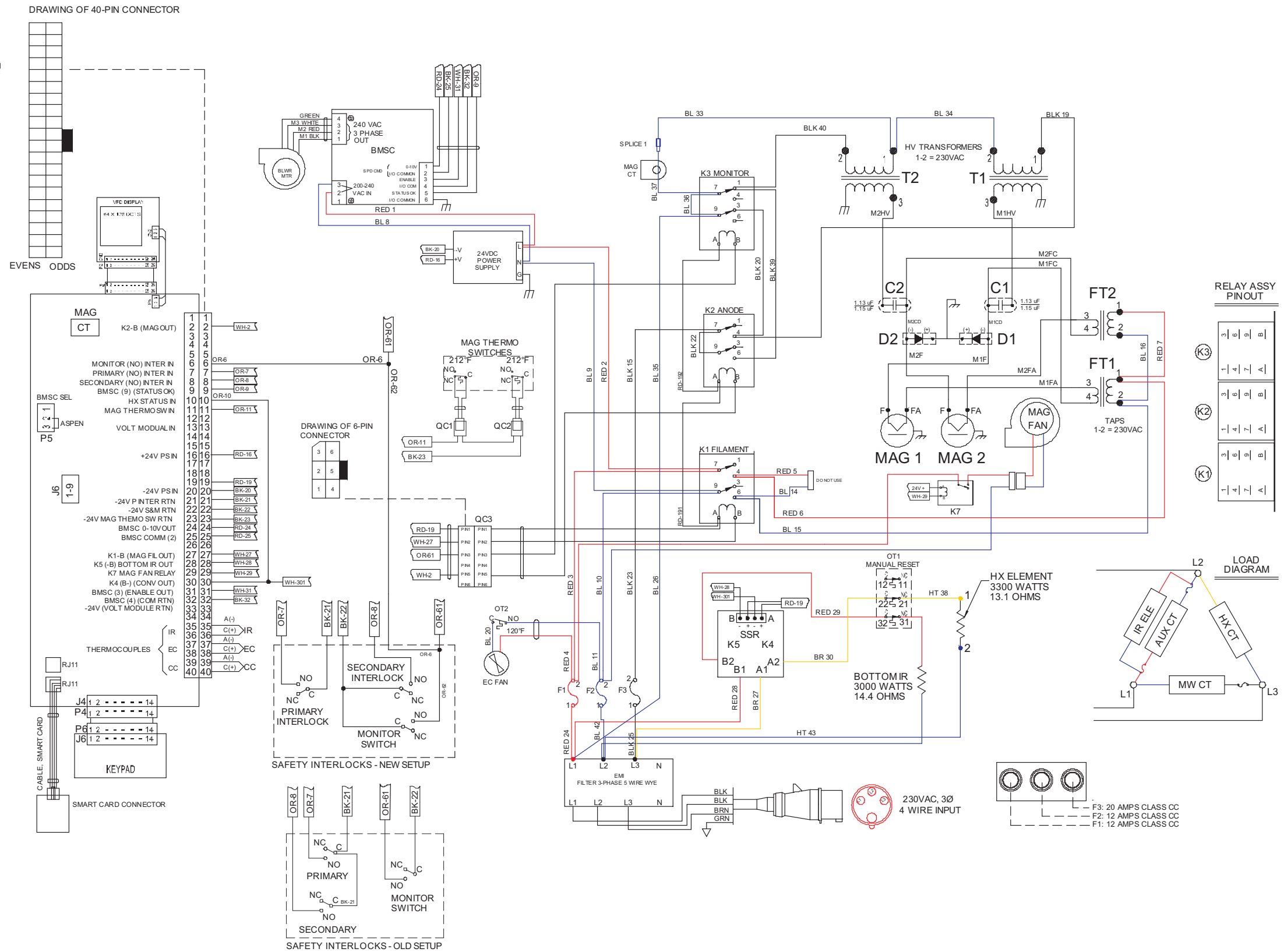

FIGURE 43: NGCED (Tornado) Schematic

NOTES:
 1. SCHEMATIC SHOWS OVEN WITH DOOR OPEN AND WITHOUT POWER APPLIED

COLOR CODE (LINE VOLTAGE)
 BL - BLUE = LINE V (220VAC)
 BK - BLACK = LINE V (220VAC)
 BR - BROWN = LINE V (220VAC)
 RED = RED LINE V (220VAC)
 HT = HI-TEMP (220VAC)

COLOR CODE (LOW/CONTROL VOLTAGE)
 BK - BLACK = 24 VDC COMMON
 DR - ORANGE = STATUS INPUT
 WH - WHITE = CONTROL OUTPUT
 RD - RED = +24VDC

COLOR CODE (HIGH VOLTAGE/TENSION)
 WH - HI-VOLTAGE WIRE FOR MAG 1
 BK - HI-VOLTAGE WIRE FOR MAG 2

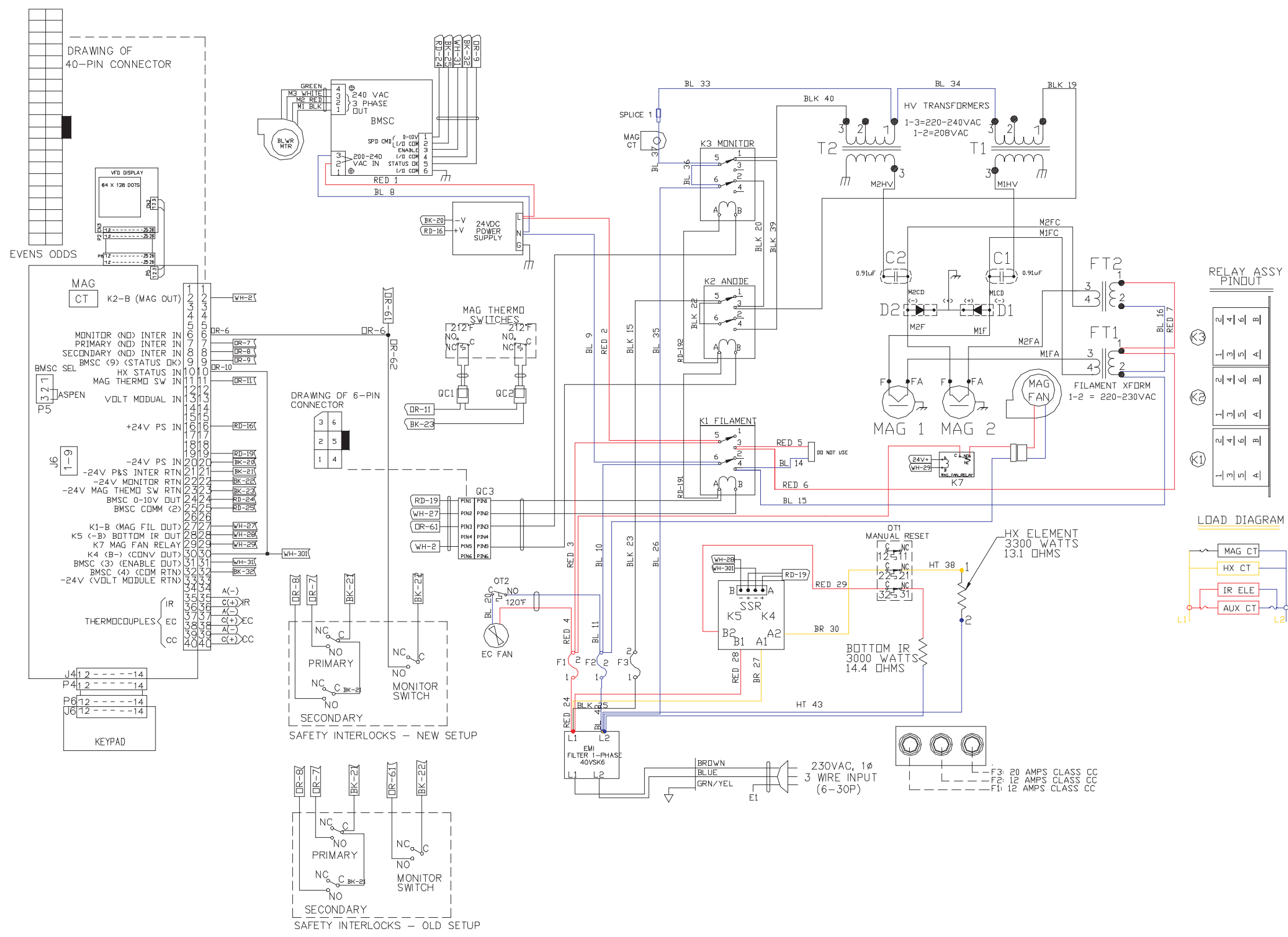

FIGURE 44: NGC Brazil (Tornado) Schematic

Service Parts and Illustrations

FIGURE 7: NGC (TORNADO) CONTROL SYSTEM

Chapter 4: The Control System - Page 13

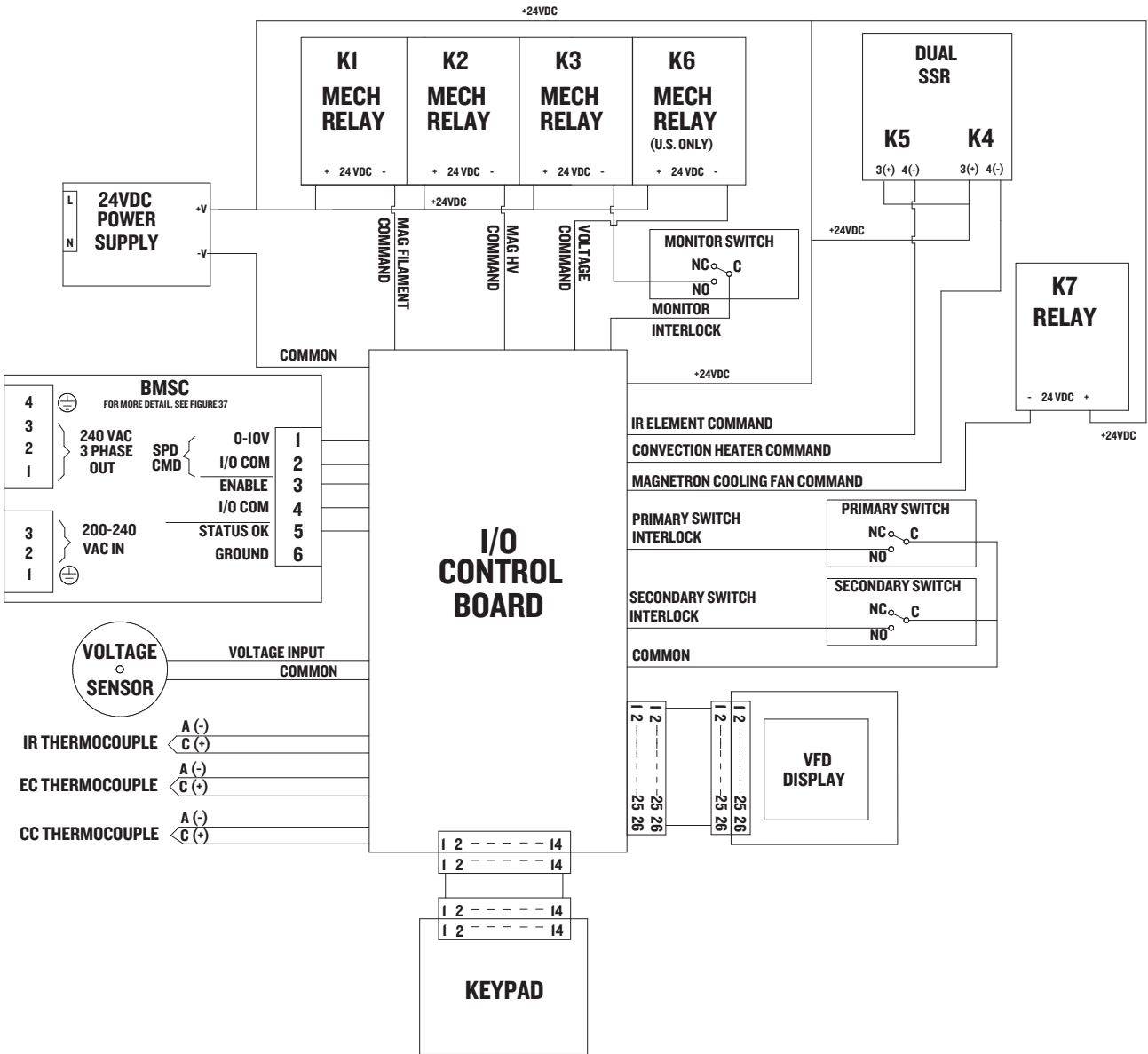

FIGURE 17: CONTROL SYSTEM PANEL ENCLOSURE AND PARTS

Chapter 4: The Control System - Page 20

**CONTROL SYSTEM PANEL PARTS**

Figure 17.

- | | | |
|----|--------------------------|---|
| 1. | NGC-1040 | Cover, Keypad/Display, Std |
| | NGC-1209 | Cover, Keypad/Display, SBK |
| 2. | 102960 | Nut, 4-40, Stainless |
| 3. | 100508 | Smart Card, Blank |
| | (Varies)* | Smart Card, Programmed* |
| 4. | NGC-3023 | Display Svc Kit (includes Items 5, 6, and 7) |
| 5. | 101954 | Spacer, 1/2" Lg, Aluminum |

- | | | |
|-----|----------------------------|-------------------------|
| 6. | 100193 | 3-Pin Power Cable |
| 7. | 100184 | 26-Pin Ribbon Cable |
| 8. | NGC-1110-1 | Keypad, NGC, Standard |
| | NGC-1110-2 | Keypad, NGC, SWY |
| | NGC-1110-3 | Keypad, NGC, SBK |
| | NGC-1110-4 | Keypad, NGC, OUT |
| 9. | 100506 | Smart Card Reader |
| 10. | 100182 | Smart Card Reader Cable |

* Contact TurboChef (800.90TURBO or +1 214.379.6000) for more info/part numbers.

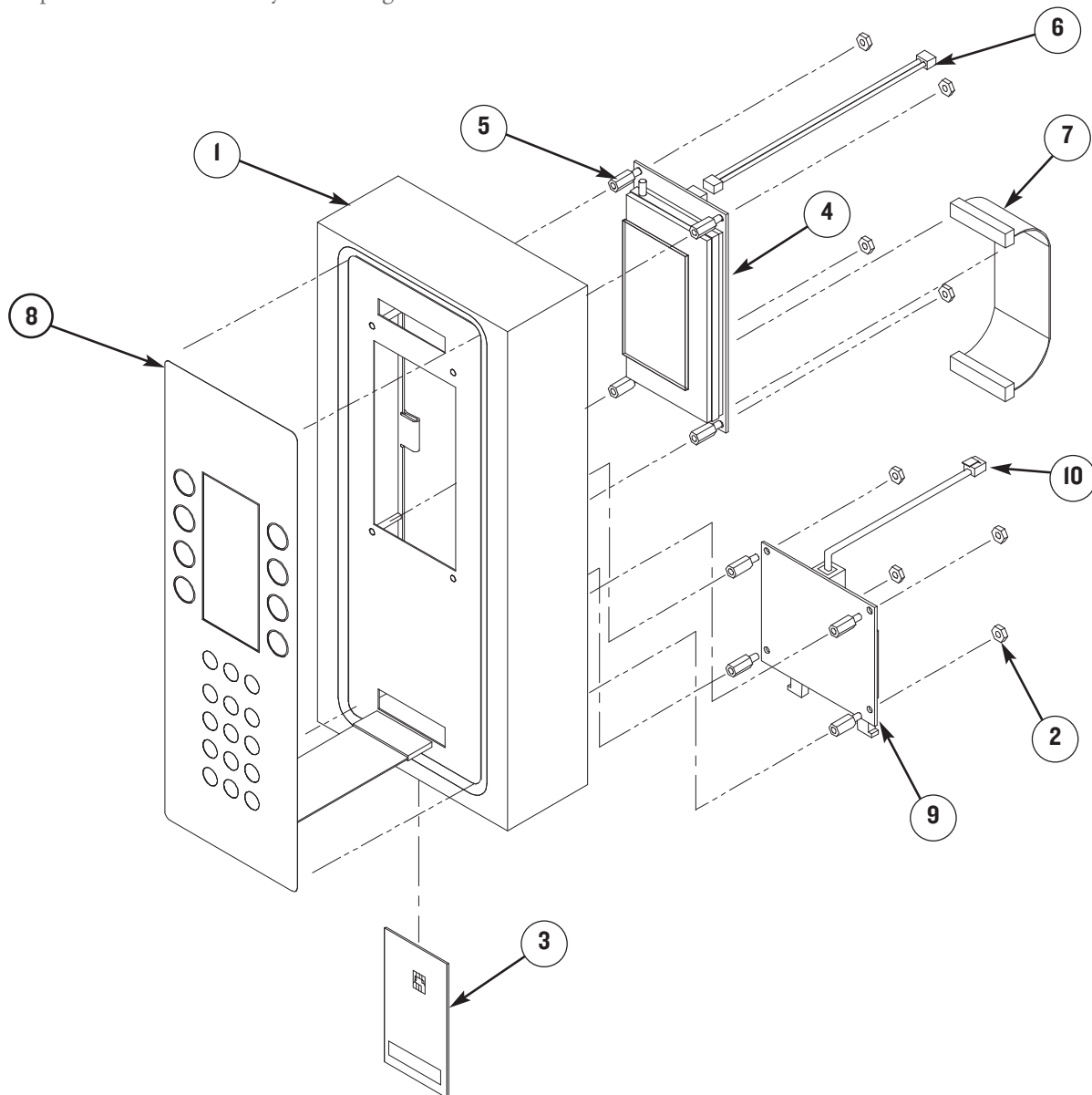
FIGURE 18: MONITOR CIRCUIT - SHOWN IN FAILSAFE STATE

Chapter 5: The Microwave System - Page 25

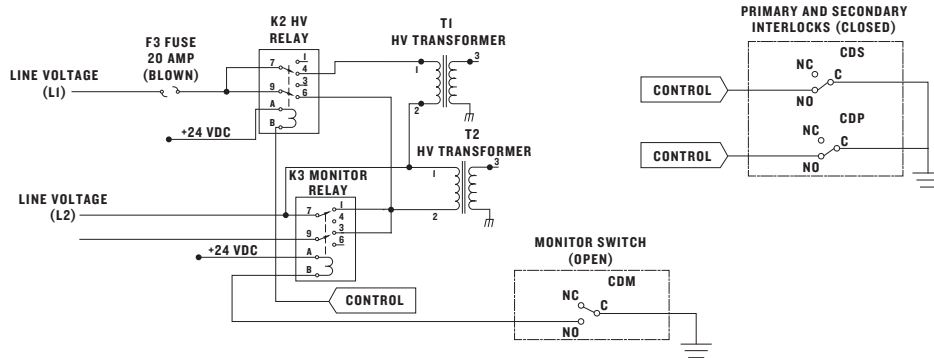

FIGURE 20: MICROWAVE SYSTEM PARTS

Chapter 5: The Microwave System - Page 27

- | | |
|--|---|
| <p>11. NGC-3062-1 HV Transformer (2 per oven, 1 per kit) USA, Latin America, Korea</p> <p>NGC-3062-2 HV Transformer (2 per oven, 1 per kit) Europe, Asia-Pacific</p> <p>NGC-3062-3 HV Transformer (2 per oven, 1 per kit) Japan</p> <p>12. NGC-3020 High Voltage Capacitor (2 per oven, 1 per kit) - USA, Latin America, Korea</p> <p>NGC-3020-2 High Voltage Capacitor (2 per oven, 1 per kit) - Europe, Asia-Pacific, Japan 50 Hz</p> <p>100207 High Voltage Capacitor (2 per oven, 1 per kit) - Japan 60 Hz</p> <p>13. 100481 High Voltage Diode (x2)</p> <p>14. Mag Fan Relay, Generic</p> <p>NGC-3030-1 North America</p> <p>NGC-3030-4 Europe, Asia-Pacific MPh</p> <p>NGC-3030-7 Europe Single Phase</p> <p>NGC-3030-12 Brazil Single Phase</p> <p>Mag Fan Relay, SWY</p> <p>NGC-3030-2 North America</p> <p>NGC-3030-6 Europe, Brazil Single Phase</p> <p>NGC-3030-9 Europe, Asia-Pacific MPh</p> <p>Mag Fan Relay, SBK</p> <p>NGC-3030-3 North America</p> <p>NGC-3030-13 Europe, Brazil Single Phase</p> <p>NGC-3030-14 Indiana/North Carolina</p> <p>NGC-3030-15 Europe, Asia-Pacific MPh</p> <p>Mag Fan Relay, Additional*</p> | <p>15. NGC-3061-1 Filament Transformer (2 per oven, 1 per kit) - USA, S. Korea</p> <p>NGC-3061-2 Filament Transformer (2 per oven, 1 per kit) - Europe, Asia- Pacific, Latin America</p> <p>NGC-3061-3 Filament Transformer (2 per oven, 1 per kit) - Japan</p> <p>16. 100083 Mag Cooling Fan</p> <p>17. 101273 K3 Monitor Relay</p> <p>18. 101273 K2 High Voltage Relay</p> <p>19. 101273 K1 Filament Relay</p> <p>20. 100599 F3 Fuse - 20 Amp</p> <p>21. NGC-3015 Magnetron (2 per oven, 1 per kit)</p> <p>22. NGC-3017 Wave Guide (Rear)</p> <p>23. NGC-3016 Wave Guide (Front)</p> <p>* See Comprehensive Part List, page 79.</p> |
|--|---|

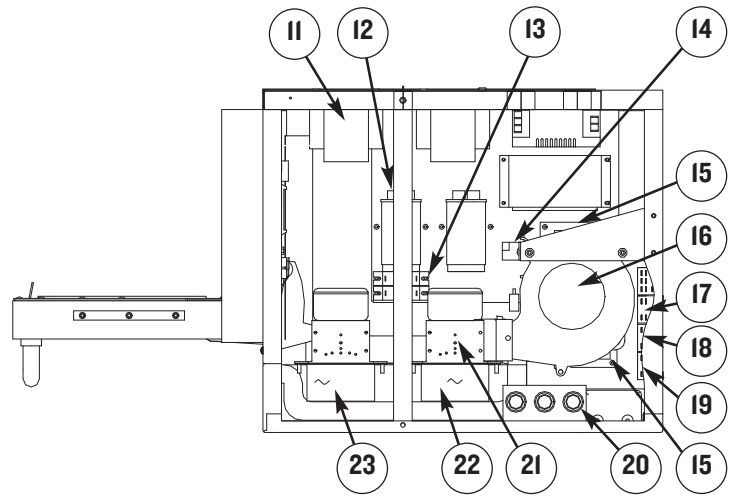
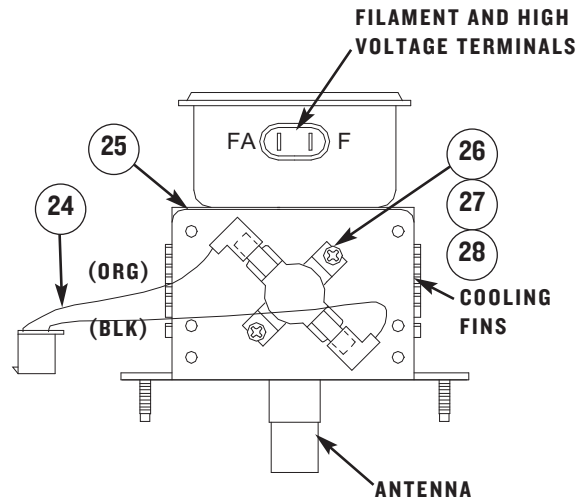

FIGURE 21: MICROWAVE SYSTEM PARTS

Chapter 5: The Microwave System - Page 27

Microwave System Parts

| | |
|--------------|----------------------|
| 24. 100186 | Magnetron Wire |
| 25. NGC-3015 | Magnetron |
| 26. 102070 | Magnetron Thermostat |
| 27. NGC-1163 | Insulator, Adhesive |
| 28. 100684 | Screw #6 Sheet Metal |

**FIGURE 22: WAVE GUIDE COVER/WAVE GUIDE REMOVAL AND REPLACEMENT**

Chapter 5: The Microwave System - Page 29

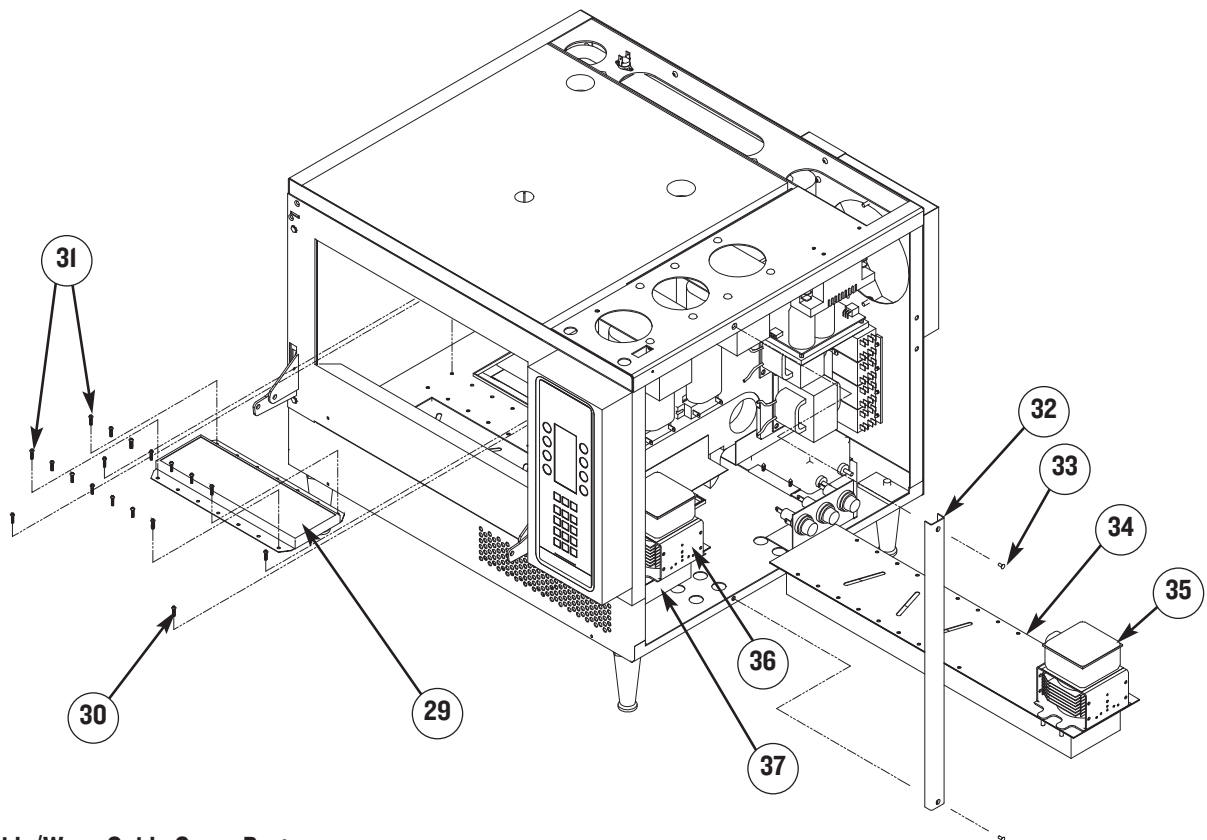
**Wave Guide/Wave Guide Cover Parts**

| | | | |
|--------------|--|--------------|---------------------------------|
| 29. NGC-3036 | Kit, Wave Guide Cover (Includes Item 31 and sealant) | 33. 102809 | Screws, #8-32 x 3/8" CSK (100°) |
| 30. 101666 | Screws, #8-32 x 1/2, Cap | 34. NGC-3017 | Assy, Wave Guide, Rear |
| 31. 101701 | Screws, #8, SST | 35. NGC-3015 | Magnetron, Rear |
| 32. NGC-1047 | Support, Frame | 36. NGC-3015 | Magnetron, Front |
| | | 37. NGC-3016 | Assy, Wave Guide, Front |

FIGURE 24 & 25: HIGH VOLTAGE DIODE AND MAGNETRON

Chapter 5: The Microwave System - Page 32

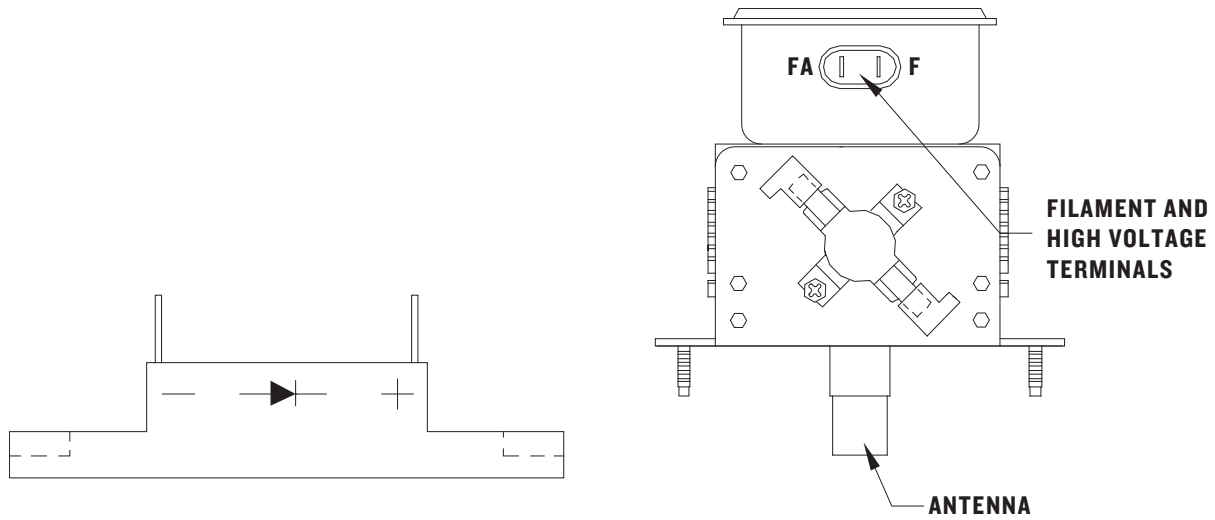

FIGURE 26: OVEN DOOR REMOVAL AND PARTS

Chapter 6: The Oven Door - Page 37

Cook Door Parts

- 38. 102809 #8-32 x 3/8" PFH CSK
- 39. NGC-3067 Assy, Oven Door (Traditional)
- NGC-3067-2 Assy, Oven Door (SBK)
- 40. NGC-1061 Hinge Block
- 41. 102804 Right Hinge
- 42. 102805 Left Hinge
- 43. 101381 #10-32 x 1/2" Hex SS
- 44. 102140 #10 Flat
- 45. 102350 #10 Split Lock
- 46. 101191 Cap, Hole

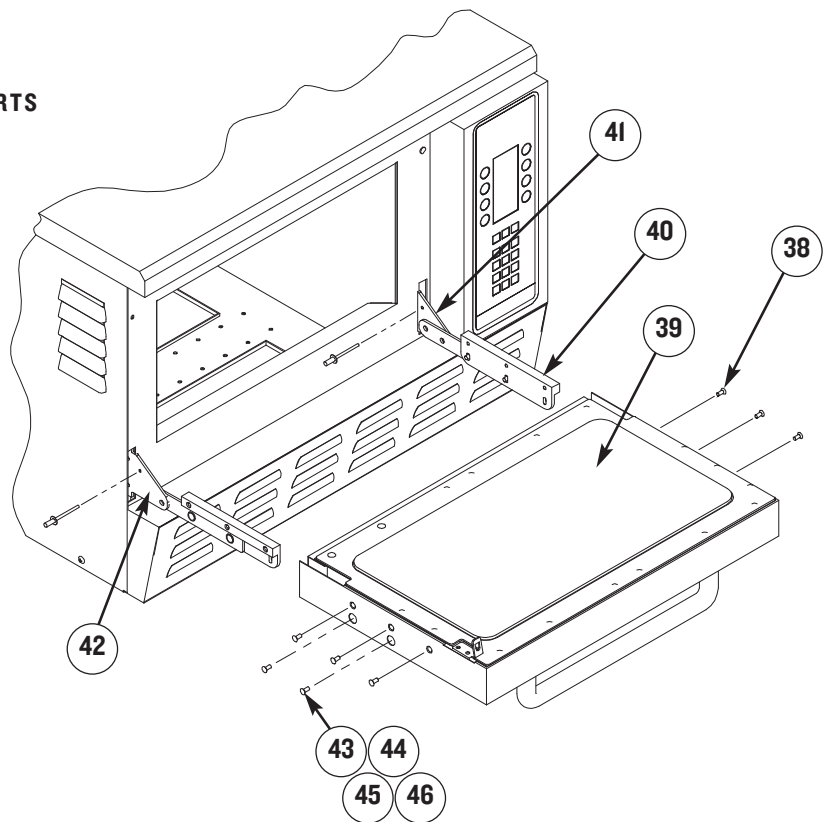

FIGURE 29: PRIMARY AND SECONDARY INTERLOCKS ADJUSTMENT AND PARTS - OLD SWITCH SETUP

Chapter 6: The Oven Door - Page 40

Primary and Secondary Interlock Switch Parts

- 47. [NGC-1076-2](#) Actuator, Door
- 48. [102809](#) Screw, #8-32 x 3/8" 100P CSK
- 49. [102921](#) Screw, #8-32 x 3/8"
- 50. [101557](#) Screw, #4-40 x 1 1/4"
- 51. [102012](#) Interlock Switches
- 52. [NGC-3033](#) Assy, Door Switch*

*See Figure 32 for Assy Detail.

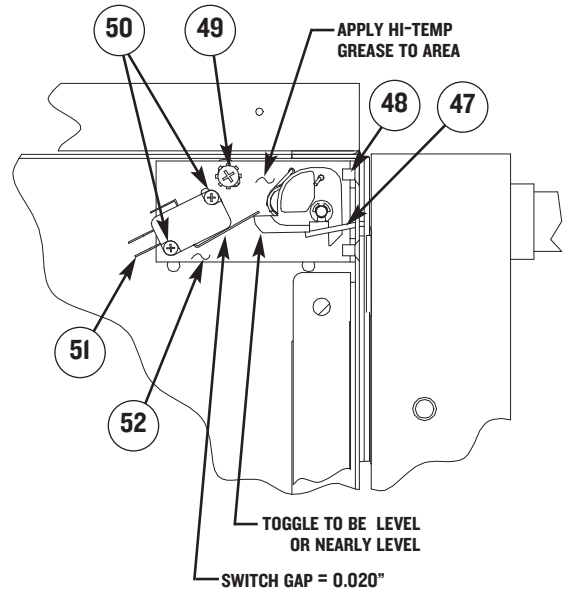

FIGURE 30: DOOR SWITCH ASSEMBLY AND PARTS

Chapter 6: The Oven Door - Page 41

Door Switch Parts

- 53. [NGC-1072](#) Bracket Latch
- 54. [102012](#) Switch, Micro, 0.1A/125VAC
- 55. [NGC-1087](#) Spring Door Latch
- 56. [NGC-1073](#) Toggle, Latch
- 57. [101119](#) Pin, Clevis, $\varnothing 3/16$ x 1" Lg
- 58. [100059](#) Bearings, Bronze, 3/16ID x 5/16OD x 1/4" Lg
- 59. [101557](#) Screw, #4-40 x 1.25" Lg, PPHD, CRES
- 60. [102921](#) Screw, #8-32 x 3/8", Internal Tooth Sems, PPHD, SS
- 61. [NGC-1126](#) Plate, Door Switch
- 62. [NGC-3006](#) Grease, USDA H-1, Food Grade
- 63. [101296](#) Ring, E-clip

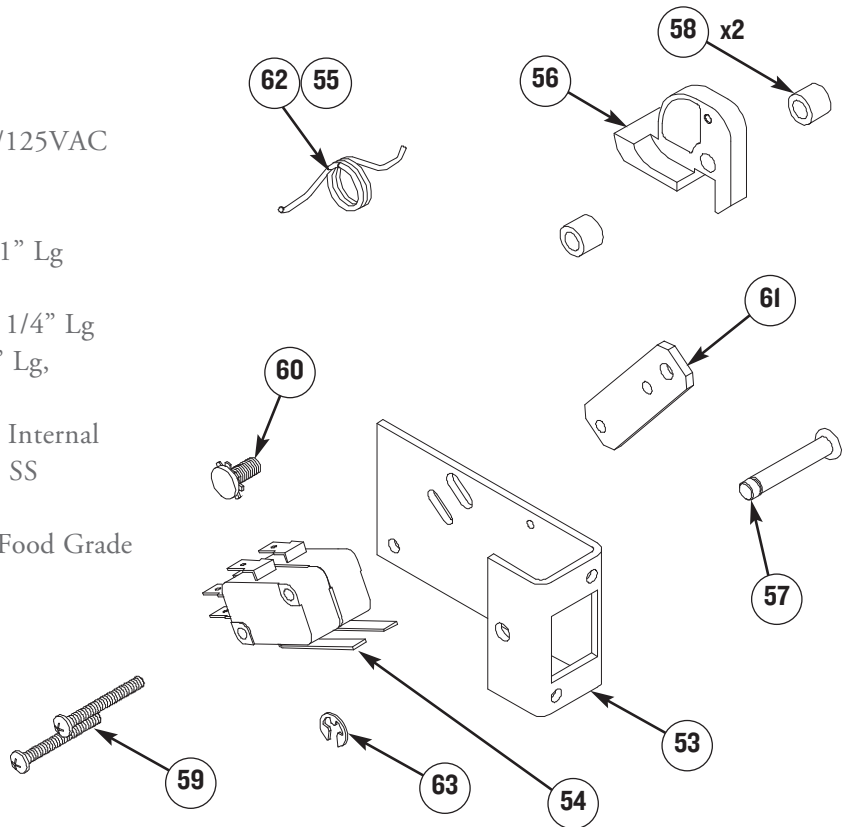
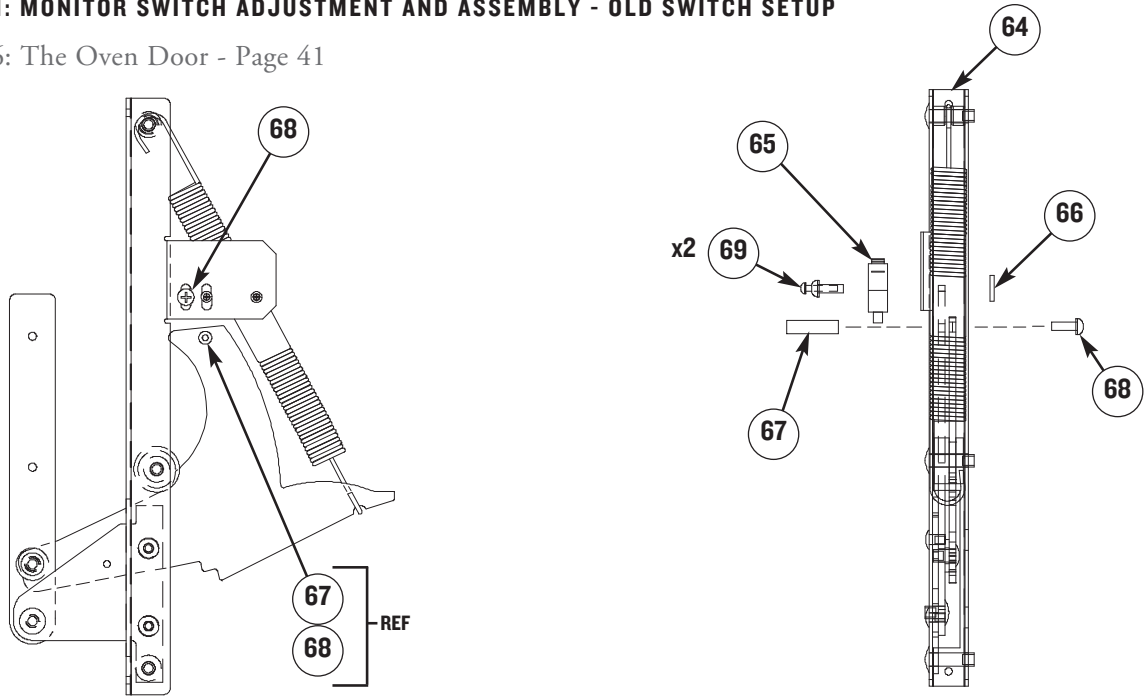

FIGURE 31: MONITOR SWITCH ADJUSTMENT AND ASSEMBLY - OLD SWITCH SETUP

Chapter 6: The Oven Door - Page 41



Monitor Safety Switch Parts

- | | | | |
|--------------|----------------------|------------|---------------------------|
| 64. 102804 | Hinge, Right | 67. 101912 | Standoff, #8-32F/Fx1 in S |
| 65. 102012 | Switch, Limit, Micro | 68. 102921 | Screw, #8-32 x 3/8" |
| 66. NGC-1126 | Plate, Door Switch | 69. 102902 | Screw, 4-40 x 5/8" |

FIGURE 32: PRIMARY INTERLOCK ADJUSTMENT AND PARTS - NEW SWITCH SETUP

Chapter 6: The Oven Door - Page 42

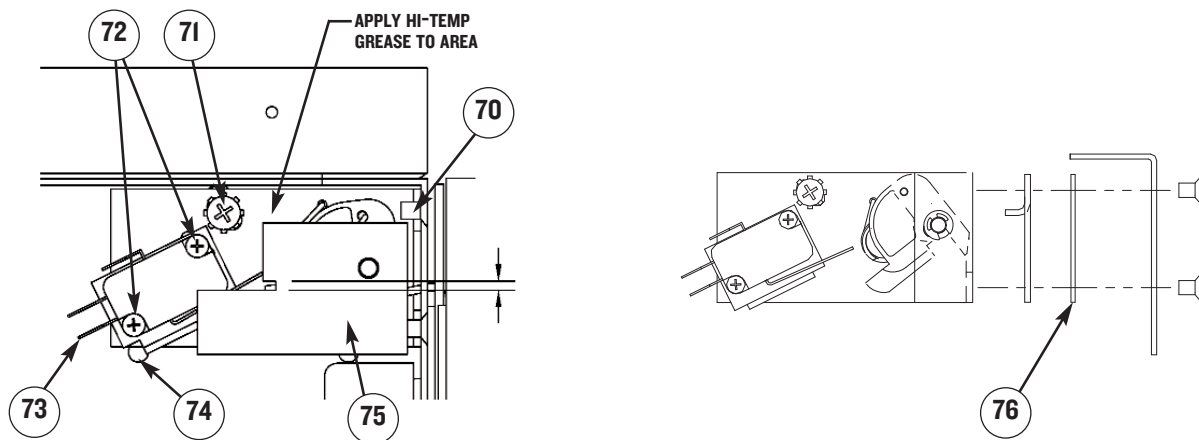

Primary Safety Switch Parts

- | | | |
|--------------|------------------------------|--|
| 70. 102809 | Screw, #8-32 x 3/8" 100P CSK | 75. Adjustment Tools (included with Item 74) |
| 71. 102921 | Screw, #8-32 x 3/8" | NGC-1215 Door Switch Gauge |
| 72. 101555 | Screw, #4-40 x 3/4" | NGC-1340 Shim Tool, 0.060" |
| 73. 102012 | Interlock Switch | NGC-1344 Shim Tool, 0.030" |
| 74. NGC-3033 | Assy, Door Switch* | 76. NGC-1169-1 Shim, 0.030" |
| | | NGC-1169-2 Shim, 0.045" |

FIGURES 33 AND 34: SECONDARY AND MONITOR SWITCH ADJUSTMENT AND ASSEMBLY - NEW SWITCH SETUP

Chapter 6: The Oven Door - Page 43

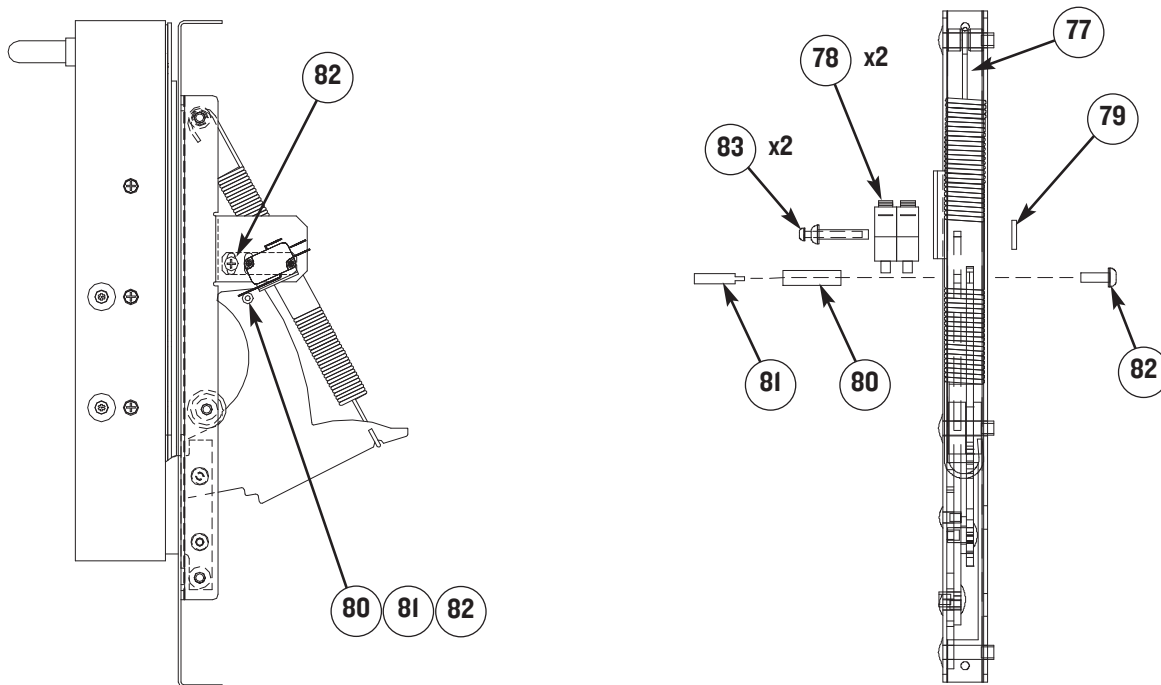
**Secondary and Monitor Safety Switch Parts**

- | | |
|--------------|--|
| 77. 102804 | Hinge, Right |
| 78. 102012 | Switch, Limit, Micro (x2) |
| 79. NGC-1126 | Plate, Door Switch |
| 80. 101914 | Standoff, #8-32 F/F x 1", 5/16" DIA |
| 81. 101915 | Standoff, #8-32 M/F x 5/16", 1/4" DIA (attached to outside of Item 80.) |
| 82. 102921 | Screw, #8-32 x 3/8" |
| 83. 101558 | Screw, 4-40 x 1.125" |

FIGURE 35: OVEN DOOR ASSEMBLY

Chapter 6: The Oven Door - Page 44

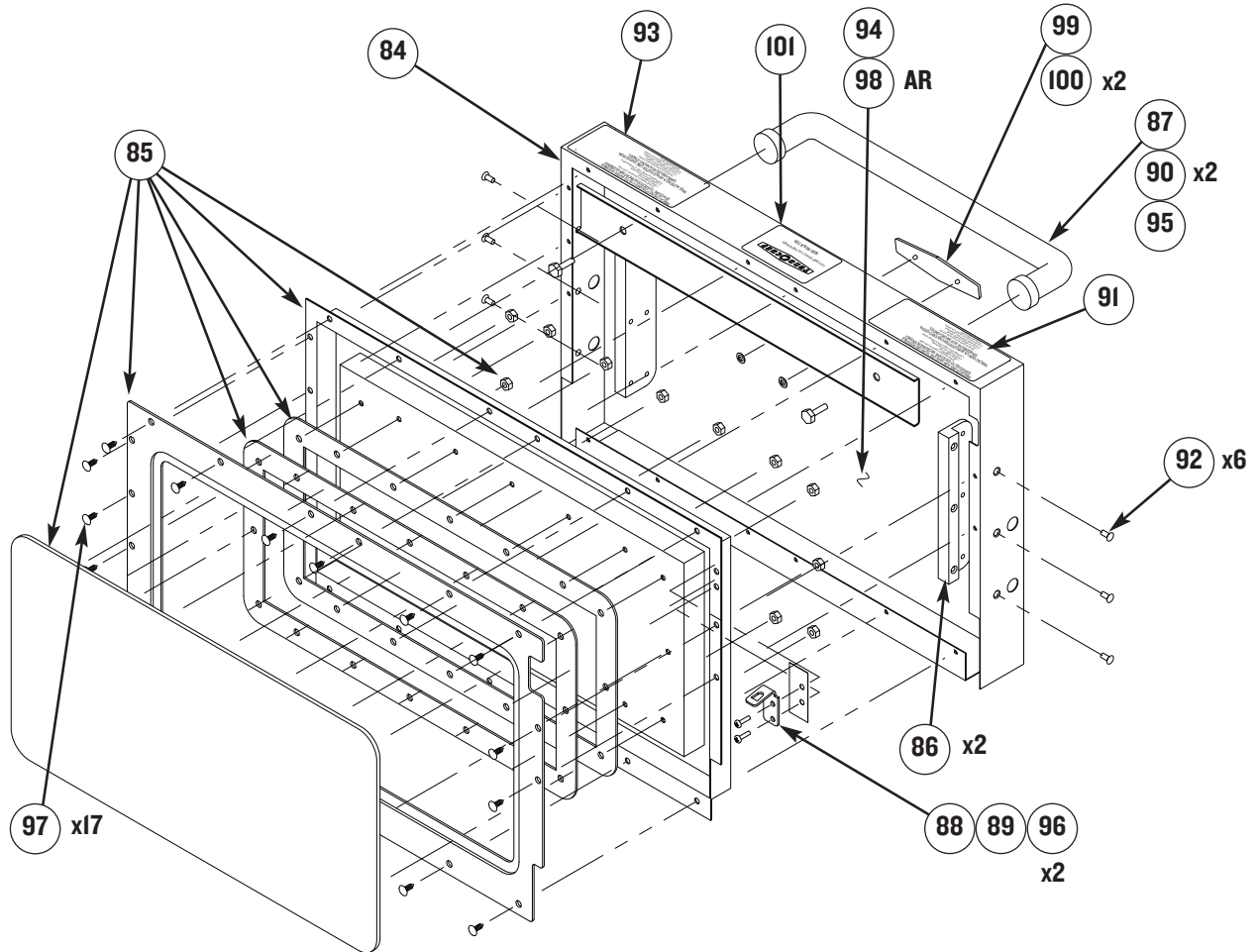

Oven Door Parts

| | | | |
|--|--|-------------------------------|------------------------------------|
| 84. NGC-3067* NGC-3067-2* | Door, NGC, Generic* Door, NGC, SBK* | 95. NGC-1127 | Channel, Door Handle |
| 85. NGC-3021 | Kit, Shunt Plate | 96. 102748 | Screw, #8-32 x 3/8", Torx Security |
| 86. NGC-1061 | Hinge Block | 97. 101688 | Screw, #8 x 1/2" PTH |
| 87. 102750 NGC-1216 | Handle, Door, Generic Handle, Door, SBK | 98. 102698 | Tape, Aluminum |
| 88. NGC-1076-2 | Actuator, Door | 99. NGC-1155 | Name Plate, TurboChef |
| 89. NGC-1132 | Shim, Door Latch | 100. 101293 | Nut, Push, 1/8" |
| 90. 102945 | Bolt, 1/4"-20 x 1.00 | 101. NGC-1170 | Label, Service |
| 91. NGC-1138 | Label, Precaution | | |
| 92. 102809 | #8-32 x 3/8" CSK 100° | | |
| 93. NGC-1165 | Label, Caution Empty | | |
| 94. NGC-1125-1 NGC-1125-2 | Door Insulation 1 Door Insulation 2 | | |

* Includes items 85 - 101.

FIGURE 37: CONVECTION CIRCUIT BLOCK DIAGRAM

Chapter 7: Convection Circuit - Page 47

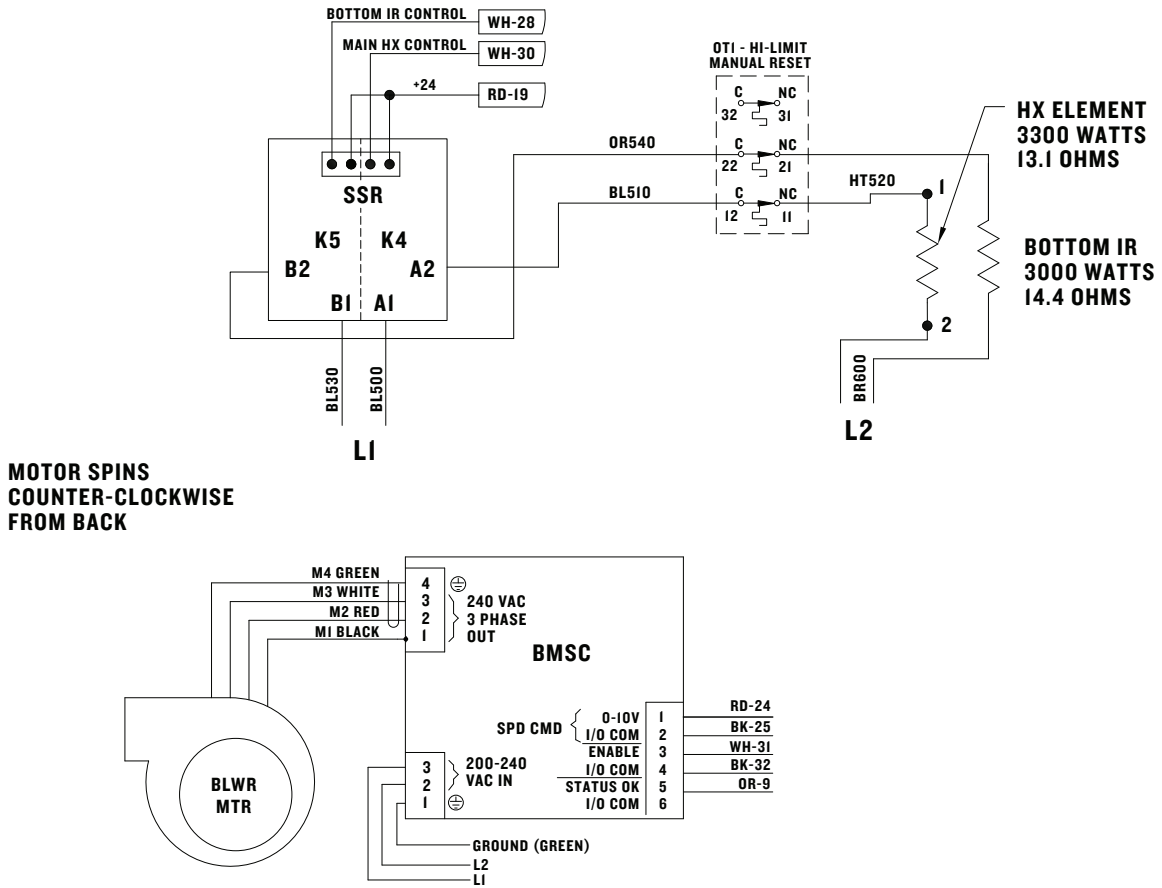
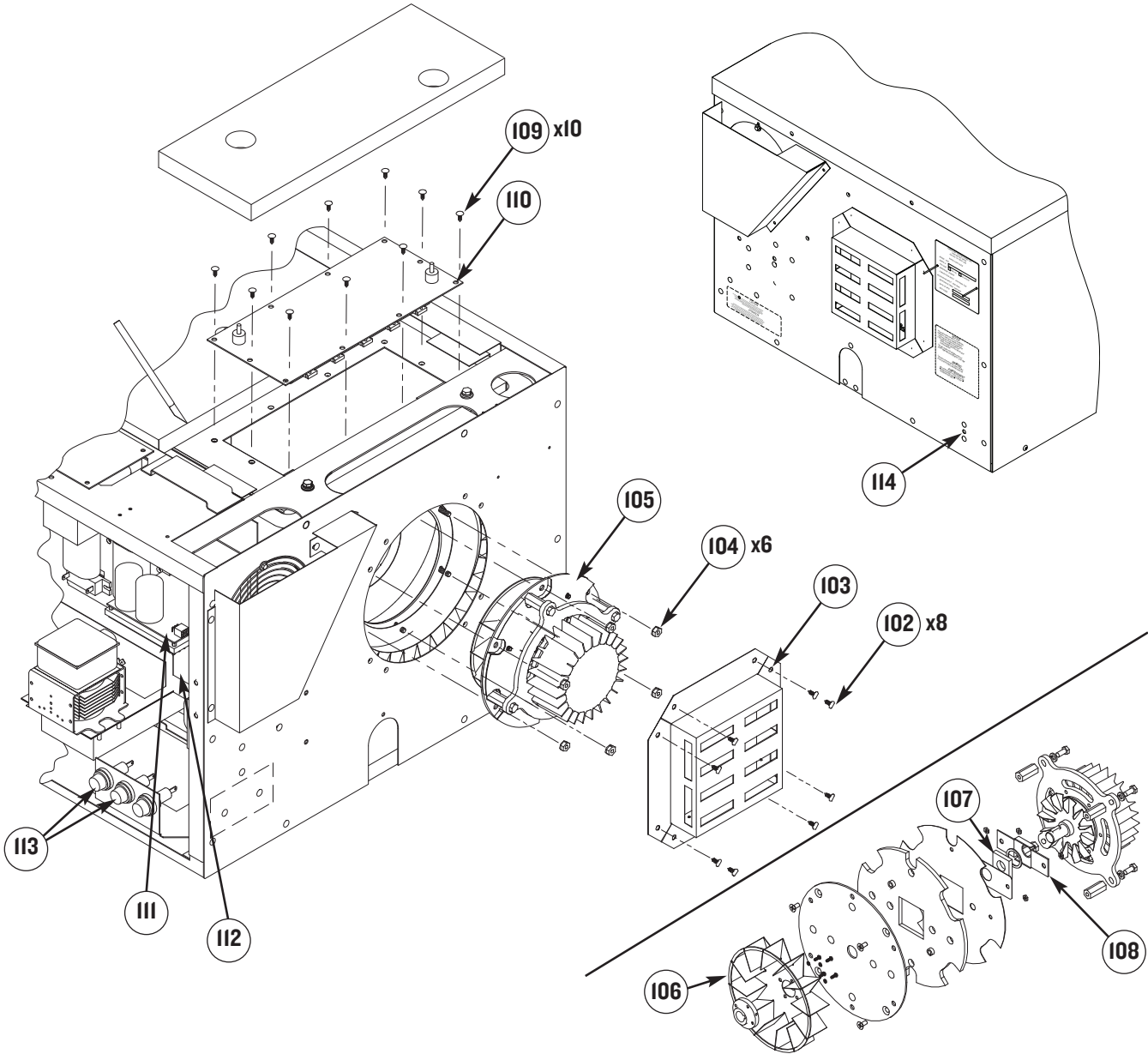

FIGURE 38: CONVECTION CIRCUIT ASSEMBLY AND PARTS

Chapter 7: Convection Circuit - Page 48



Convection Circuit Parts

- 102. 101688 Screw, #8 x 1/2" PTH
- 103. NGC-1081 Cover, Motor
- 104. 100906 Nut, 1/4"-20, Flange
- 105. NGC-1025 Assy, Blower Motor
- * 106. NGC-3007 Kit, Fan Blade
- * 107. NGC-1024 Sealing Block, Blower
- * 108. NGC-1023 Clamp, Blower Seal
- 109. 101688 Screw, #8 x 1/2" PTH
- 110. NGC-3011 Heater, Convection
- 111. 100443 Controller, Motor

- 112. NGC-3005 Relay, K4/K5 SSR
- 113. 100592 Fuses, F1 and F2 (12 Amp)
- 114. 102075 High-Limit Thermostat
- ** 115. NGC-1043 Gasket, Convection Heater

* If entire motor is needed, order NGC-1025.
 If only hardware (screws, nuts) or seal is needed,
 contact 800.90TURBO or +1 214-379-6000.

** Not shown for clarity.

FIGURE 39: IR ELEMENT AND CATALYTIC CONVERTER PARTS AND ASSEMBLY

Chapter 8: IR Element and Catalytic Converter - Page 52

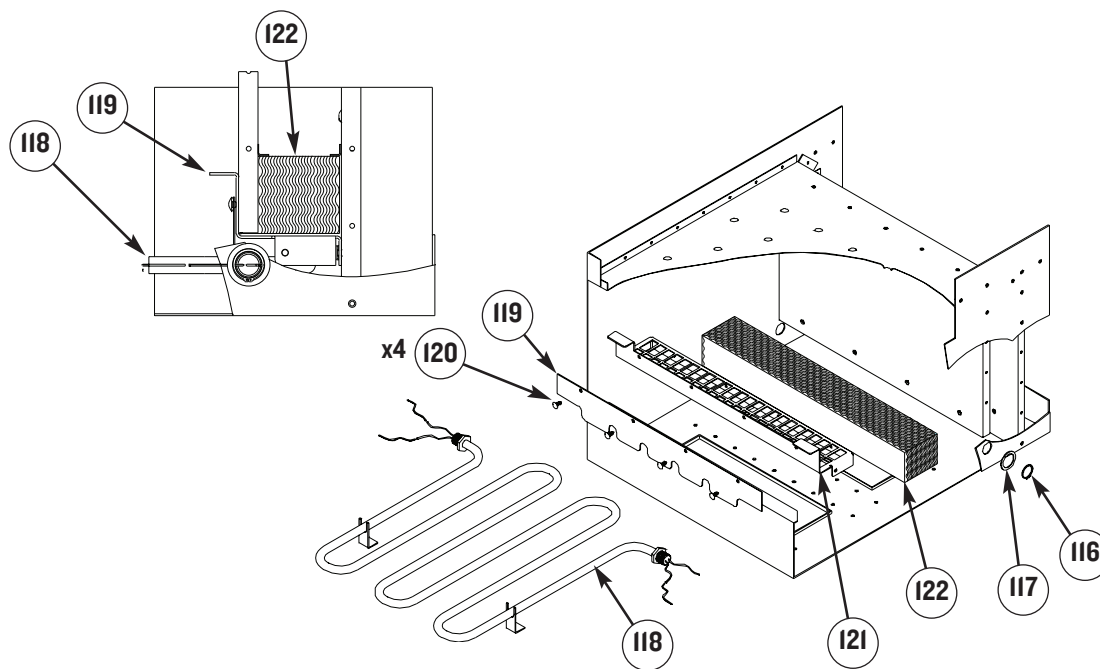
**IR Element and Catalytic Converter Parts**

| | | | |
|---------------|--------------------------------|---------------|-------------------------------------|
| 116. 101312 | Snap Ring | 121. NGC-1030 | Clip, Catalytic Converter (Non-SBK) |
| 117. 102449 | Washer, Shim | NGC-1233 | Clip, Catalytic Converter (SBK) |
| 118. NGC-3003 | IR Element | 122. NGC-1012 | Catalytic Converter |
| 119. NGC-1116 | Shield, Microwave | | |
| 120. 101688 | Screw, #8 x 1/2" Sht Metal PTH | | |

Wire Harness Replacement P/N**Low Voltage Harness**

| | |
|-------------|------------------|
| 123. 100185 | Old Switch Setup |
| NGC-1418 | New Switch Setup |

Line Voltage Harness

| | |
|-----------------|------------------------------|
| 124. NGC-1150-1 | North America |
| NGC-1150-2 | UK, Ireland, Brazil |
| NGC-1150-3 | Eu, Asia, Pacific, Au, Japan |

Magnetron Wire

| | |
|-------------|---------------|
| 125. 100186 | All NGC Ovens |
|-------------|---------------|

Power Cord

| | |
|-------------|--------------------------------|
| 126. 100187 | USA |
| 100194 | NGC ED - Europe, Asia, Pacific |
| 100195 | UK, Ireland, Brazil |
| 103187 | NGC EW- Europe, Asia, Pacific |
| 103195 | Australia |
| NGC-1383 | Japan 3Ph |
| NGC-1390 | Japan 1Ph |

FIGURE 46: COVERS AND MISCELLANEOUS PARTS - NON-SBK OVENS

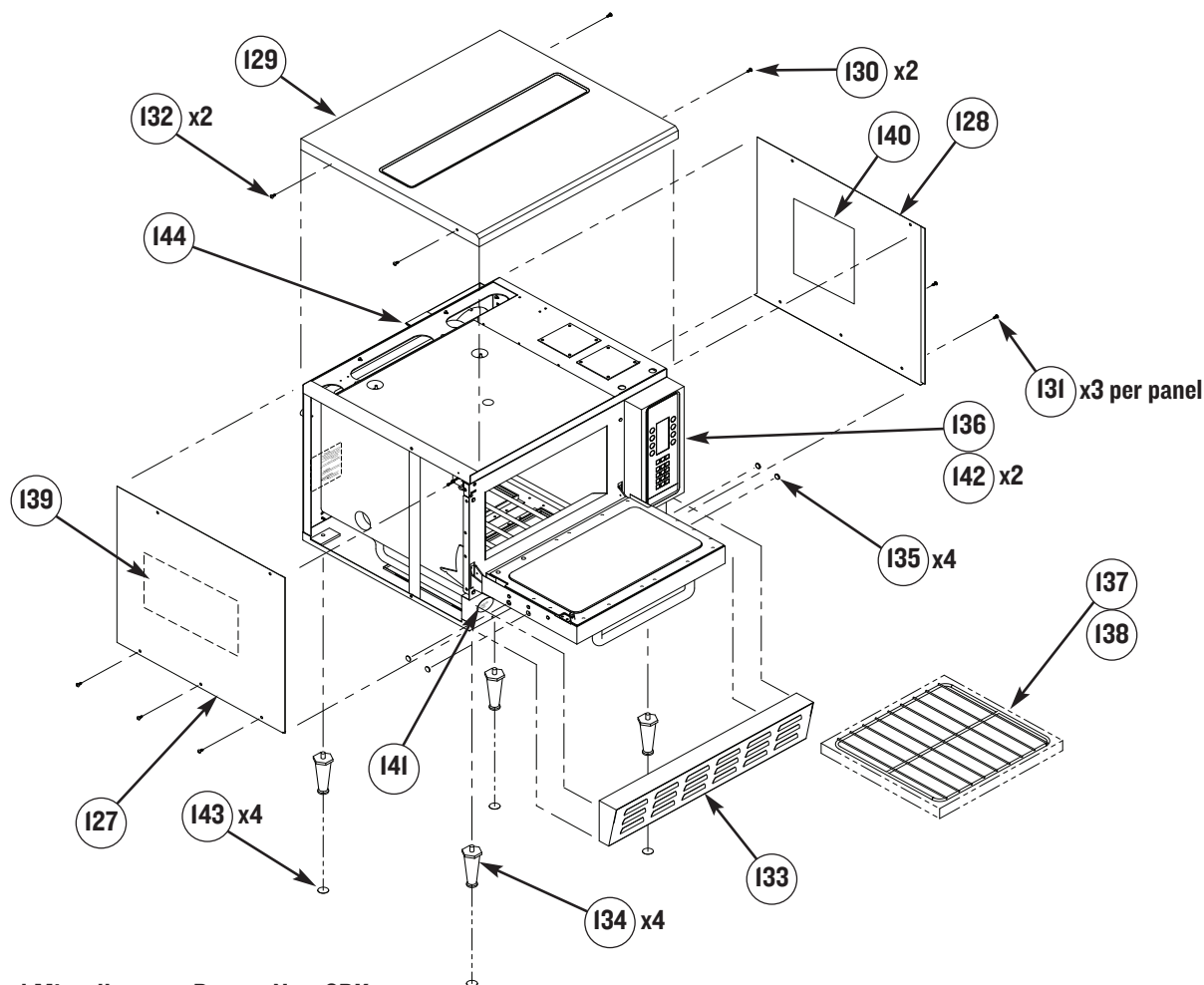

Covers and Miscellaneous Parts - Non-SBK

| | | | |
|-----------------|---|-----------------|--|
| 127. NGC-1069-1 | Cover, Left Side | NGC-1274 | Rack, Recessed (International) |
| 128. NGC-1069-2 | Cover, Right Side | NGC-3064 | Rack, Raised |
| 129. NGC-1068 | Cover, Top | 138. NGC-3037 | Stone, Unglazed |
| 130. 102752 | Screw, #8-16 TORX HD Security | NGC-3038 | Stone, Clear Glazed |
| 131. 101688 | Screw, #8 Serrated Phillips TRHD, CRES | NGC-3063 | Stone, Fiber-Reinforced |
| 132. 102921 | Screw, #8-32 x 3/8", PPHD, SEM, Int Tooth, SS | 139. NGC-1176-1 | Label, Schematic (N. America) |
| 133. NGC-1071-2 | Cover, Bottom Front | NGC-1176-2 | Label, Schematic (UK/Ireland) |
| 134. 100785 | Leg, NGC, Black Plastic | NGC-1176-3 | Label, Schematic (Eu/Asia/Pac 400VAC) |
| 100781 | Leg, NGC, Stainless Steel | NGC-1176-4 | Label, Schematic (Eu/Asia/Pac 230 VAC) |
| 135. 101191 | Hole Plug, 1/2" Dia, Black | NGC-2020 | Label, Schematic (Gen. Brazil) |
| 136. NGC-1054-1 | Assy, Keypad/Display, Cover, Standard | 140. NGC-1177 | Label, Service Assistance |
| NGC-1054-2 | Assy, Keypad/Display, Cover, Subway | 141. NGC-1148 | Label, Caution Hot |
| 137. NGC-1064-1 | Rack, Standard (USA) | 142. 102962 | Nut, KEPS HEX, #8-32, Ext Tooth, CRES |
| | | 143. NGC-1187 | Pad, Abrasive Non-slip |
| | | 144. NGC-1082 | Cover, Cooling Fan |

FIGURE 47: COVERS AND MISCELLANEOUS PARTS - SBK OVENS

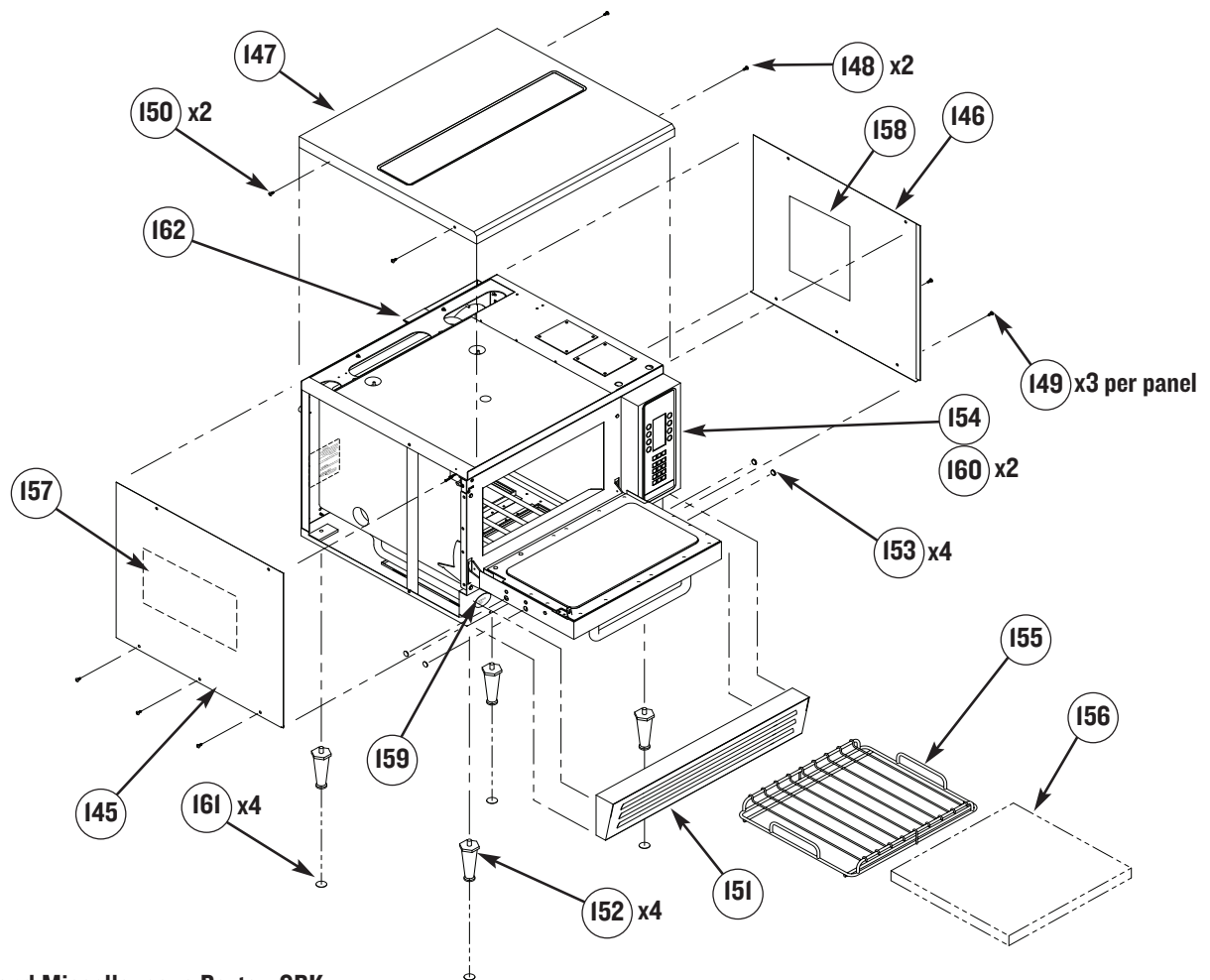
**Covers and Miscellaneous Parts - SBK**

| | | | |
|---------------------------------|--|---------------------------------|---|
| 145. NGC-1213-1 | Cover, Left Side | 156. NGC-3038 | Stone, Clear Glazed |
| 146. NGC-1213-2 | Cover, Right Side | 157. NGC-1176-1 | Label, Schematic (USA) |
| 147. NGC-1211 | Cover, Top | NGC-1176-2 | Label, Schematic (UK/Ireland) |
| 148. 102756 | Screw, #8 x 1/2 Lg TORX HD Security | NGC-1176-3 | Label, Schematic (Eu/Asia/Pac 400VAC) |
| 149. 101691 | Screw, #8 Serrated Phillips TRHD, CRES | NGC-1176-4 | Label, Schematic (Eu/Asia/Pac 230 VAC) |
| 150. 102922 | Screw, #8-32 x 3/8", PPHD, SEM, Int Tooth, SS | NGC-2011-8 | Label, Schematic (Latin America) |
| 151. NGC-1212 | Cover, Bottom Front | 158. NGC-1177 | Label, Service Assistance |
| 152. 100784 | Leg, NGC, SBK, 4" (qty 1) | 159. NGC-1148 | Label, Caution Hot |
| 153. 101191 | Hole Plug, 1/2" Dia, Black | 160. 102962 | Nut, KEPS HEX, #8-32, Ext Tooth, CRES |
| 154. NGC-1054-3 | Assy, Keypad/Display, Cover | 161. NGC-1187 | Pad, Abrasive Non-slip |
| 155. NGC-3064 | Rack, Raised | 162. NGC-1082 | Cover, Cooling Fan |

Comprehensive Part List

| ITEM DESCRIPTION | PART NUMBER | FIGURE NUMBER (PAGES 65-78) |
|--|-------------|-----------------------------|
| Actuator, Door | NGC-1076-2 | 29, 35 |
| Assembly, Keypad/Housing, Cover, Standard | NGC-1054-1 | 46 |
| Assembly, Keypad/Housing, Cover, SWY | NGC-1054-2 | 46 |
| Assembly, Keypad/Housing, Cover, SBK | NGC-1054-3 | 47 |
| Bearings, Bronze, 3/16 ID x 5/16 OD x 1/4 | 100059 | 30 |
| Block, Hinge | NGC-1061 | 26, 35 |
| Block, Sealing, Blower Motor | NGC-1024 | 38 |
| Blower Motor | NGC-1025 | 38 |
| Bolt, 1/4-20 x 1.00 | 102945 | 35 |
| Bracket, Stacking | TC3-0323 | None |
| Cable, Ribbon, 26-Pin | 100184 | 17 |
| Cable, Smart Card Reader | 100182 | 17 |
| Cable, VF Display, 3-Pin | 100193 | 17 |
| Cap, Hole, Door | 101191 | 26 |
| Capacitor, HV (Europe, Asia-Pacific) | NGC-3020-2 | 20 |
| Capacitor, HV (Japan) | 100207 | 20 |
| Capacitor, HV (USA, Latin America, S. Korea) | NGC-3020 | 20 |
| Cart, TurboChef Oven, 18" | NGC-1217-2 | 4 (Page 4) |
| Cart, TurboChef Oven, 24" | NGC-1217-1 | 4 (Page 4) |
| Catalytic Converter | NGC-1012 | 39 |
| Channel, Door Handle | NGC-1127 | 35 |
| Clamp, Blower Seal | NGC-1023 | 38 |
| Cleaner, TurboChef Oven, Domestic | 103180 | None |
| Cleaner, TurboChef Oven, International | 103380 | None |
| Cleaner, Wave Guide Cover, Domestic | 103183 | None |
| Cleaner, Wave Guide Cover, International | 103383 | None |
| Clip, Catalytic Converter, Standard | NGC-1030 | 39 |
| Clip, Catalytic Converter, SBK | NGC-1233 | 39 |
| Cord, Power (Australia) | 103195 | None |
| Cord, Power (Japan 1Ph) | NGC-1390 | None |
| Cord, Power (Japan 3Ph) | NGC-1383 | None |
| Cord, Power (NGC ED - Europe, Asia-Pacific) | 100194 | None |
| Cord, Power (NGC EW - Europe, Asia-Pacific) | 103187 | None |
| Cord, Power (UK, Ireland, Brazil) | 100195 | None |
| Cord, Power (USA) | 100187 | None |
| Cover, Bottom Front, Standard | NGC-1071-2 | 46 |
| Cover, Bottom Front, SBK | NGC-1212 | 47 |
| Cover, Cooling Fan | NGC-1082 | 46, 47 |
| Cover, Keypad/Display, Standard | NGC-1040 | 17 |
| Cover, Keypad/Display, SBK | NGC-1209 | 17 |
| Cover, Left Side, Standard | NGC-1069-1 | 46 |
| Cover, Left Side, SBK | NGC-1213-1 | 47 |
| Cover, Motor | NGC-1081 | 38 |
| Cover, Right Side, Standard | NGC-1069-2 | 46 |
| Cover, Right Side, SBK | NGC-1213-2 | 47 |
| Cover, Top, Standard | NGC-1068 | 46 |
| Cover, Top, SBK | NGC-1211 | 47 |
| Cover, Wave Guide | NGC-3036 | 22 |
| Diode, HV | 100481 | 20 |
| Display | NGC-3023 | 17 |
| Door, Standard | NGC-3067 | 26, 35 |
| Door, SBK | NGC-3067-2 | 26, 35 |

| ITEM DESCRIPTION | PART NUMBER | FIGURE NUMBER (PAGES 65-78) |
|---|-------------|-----------------------------|
| Fan Blade, Motor | NGC-3007 | 38 |
| Fan, Magnetron Cooling | 100083 | 20 |
| Filter, EMI, 1Ph (USA, Europe, Latin America, Japan) | 100543 | None |
| Filter, EMI, 3Ph (Europe, Asia-Pacific, Korea, Japan) | 100545 | None |
| Fuse, F1, 12 Amp | 100592 | 38 |
| Fuse, F2, 12 Amp | 100592 | 38 |
| Fuse, F3, 20 Amp | 100599 | 20 |
| Gasket, Convection Heater | NGC-1043 | 38 |
| Gauge, Door Switch (Adjustment Tool) | NGC-1215 | 32 |
| Grease, Food Grade, USDA H-1 | NGC-3006 | 30 |
| Guard, TurboChef Oven, Domestic | 103181 | None |
| Guard, TurboChef Oven, International | 103381 | None |
| Handle, Door, Standard | 102750 | 35 |
| Handle, Door, SBK | NGC-1216 | None |
| Harness, Line Voltage (Europe, Asia-Pacific, Japan) | NGC-1150-3 | None |
| Harness, Line Voltage (North America) | NGC-1150-1 | None |
| Harness, Line Voltage (UK, Ireland, Brazil) | NGC-1150-2 | None |
| Harness, Low Voltage, Old Switch Setup | 100185 | None |
| Harness, Low Voltage, New Switch Setup | NGC-1418 | None |
| Heater Element, IR | NGC-3003 | 39 |
| Heater, Convection | NGC-3011 | 38 |
| Hinge, Left | 102805 | 26 |
| Hinge, Right | 102804 | 26, 31, 33, 34 |
| Insulation, Door, 1 | NGC-1125-1 | 35 |
| Insulation, Door, 2 | NGC-1125-2 | 35 |
| Insulator, Adhesive | NGC-1163 | 21 |
| Keypad, OUT | NGC-1110-4 | 17 |
| Keypad, Standard | NGC-1110-1 | 17 |
| Keypad, SBK | NGC-1110-3 | 17 |
| Keypad, SWY | NGC-1110-2 | 17 |
| Label, Caution, Empty Cavity | NGC-1165 | 35 |
| Label, Caution, Hot | NGC-1148 | 46, 47 |
| Label, Precaution for Safe Use | NGC-1138 | 35 |
| Label, Schematic (Europe, Asia-Pacific, 230 VAC) | NGC-1176-4 | 46, 47 |
| Label, Schematic (Europe, Asia-Pacific, 400 VAC) | NGC-1176-3 | 46, 47 |
| Label, Schematic (USA) | NGC-1176-1 | 46, 47 |
| Label, Schematic (UK, Ireland) | NGC-1176-2 | 46, 47 |
| Label, Schematic, Standard (Latin America) | NGC-2020 | 46 |
| Label, Schematic, SBK (Latin America) | NGC-2011-8 | 47 |
| Label, Service Assistance | NGC-1177 | 46, 47 |
| Label, Service Number | NGC-1170 | 35 |
| Latch, Bracket | NGC-1072 | 30 |
| Latch, Spring Door | NGC-1087 | 30 |
| Leg, 4", Black Plastic | 100785 | 46 |
| Leg, 4", Standard, Stainless Steel | 100781 | 46 |
| Leg, 4", SBK | 100784 | 47 |
| Leg, 7", SBK Kit (4 legs) | NGC-3068 | 47 |
| Magnetron | NGC-3015 | 20, 21 |
| Motor Controller | 100443 | 38 |
| Nameplate, TurboChef | NGC-1155 | 35 |
| Nut, Crescent, Keps, Hex, #8-32, External Tooth | 102692 | 46, 47 |

| ITEM DESCRIPTION | PART NUMBER | FIGURE NUMBER (PAGES 65-78) |
|---|-------------|-----------------------------|
| Nut, Flange, 1/4-20 | 100906 | 38 |
| Nut, M5, Yellow Zinc (Magnetrons, Bottom Electrical Plate) | 100101 | None |
| Nut, Push, 1/8 | 101293 | 35 |
| Nut, Stainless, #4-40 | 102960 | 17 |
| Pad, Abrasive, Non-Slip | NGC-1187 | 46, 47 |
| Pin, Clevis, 3/16 Diameter x 1" Long | 101119 | 30 |
| Plate, Door Switch | NGC-1126 | 30, 31, 33, 34 |
| Plug, Hole, Black, 1/2" Diameter | 101191 | 46, 47 |
| Rack, Raised | NGC-3064 | 46, 47 |
| Rack, Recessed | NGC-1274 | 46 |
| Rack, Standard | NGC-1064-1 | 46 |
| Reader, Smart Card | 100506 | 17 |
| Relay, K1, Filament Transformers | 101273 | 20 |
| Relay, K2, HV Transformers | 101273 | 20 |
| Relay, K3, Monitor | 101273 | 20 |
| Relay, K4/K5, Solid State, Convection Heater/IR Element | NGC-3005 | 38 |
| Relay, K6, 208/240 Transformer Taps (USA only) | 101272 | None |
| Relay, K7, Magnetron Fan, DNK | NGC-3030-11 | None |
| Relay, K7, Magnetron Fan, OXXO | NGC-3030-5 | None |
| Relay, K7, Magnetron Fan, SBK (USA) | NGC-3030-3 | 20 |
| Relay, K7, Magnetron Fan, SBK (Europe, Asia-Pacific MPh) | NGC-3030-15 | 20 |
| Relay, K7, Magnetron Fan, SBK (Europe SPh) | NGC-3030-13 | 20 |
| Relay, K7, Magnetron Fan, SBK (Indiana/North Carolina) | NGC-3030-14 | 20 |
| Relay, K7, Magnetron Fan, Standard (USA) | NGC-3030-1 | 20 |
| Relay, K7, Magnetron Fan, Standard (Europe, Asia-Pacific MPh) | NGC-3030-4 | 20 |
| Relay, K7, Magnetron Fan, Standard (Europe SPh) | NGC-3030-7 | 20 |
| Relay, K7, Magnetron Fan, Standard (Latin America) | NGC-3030-12 | 20 |
| Relay, K7, Magnetron Fan, SWY (USA) | NGC-3030-2 | 20 |
| Relay, K7, Magnetron Fan, SWY (Europe, Asia-Pacific MPh) | NGC-3030-9 | 20 |
| Relay, K7, Magnetron Fan, SWY (Europe, Latin America SPh) | NGC-3030-6 | 20 |
| Relay, K7, Magnetron Fan, TESCO | NGC-3030-10 | None |
| Relay, K7, Magnetron Fan, WAWA | NGC-3030-8 | None |
| Ring, E-clip | 101296 | 30 |
| Ring, Snap | 101312 | 39 |
| Screw, #4-40 x 5/8 | 102902 | 31 |
| Screw, #4-40 x 3/4 | 101555 | 32 |
| Screw, #4-40 x 1 1/8 | 101558 | 33, 34 |
| Screw, #4-40 x 1 1/4 | 101557 | 29, 30 |
| Screw, #6, Sheet Metal | 100684 | 21 |
| Screw, #8, Crescent, TRHD, Serrated Phillips | 101688 | 35, 38, 39, 46 |
| Screw, #8, Crescent, TRHD, Serrated Phillips, Black Oxide | 101691 | 47 |
| Screw, #8-16, Torx Security | 102752 | 46 |
| Screw, #8-16 x 1/2, Torx Security, Black Oxide | 102756 | 47 |
| Screw, #8-18, SS | 101701 | 22 |
| Screw, #8-32 x 3/8 | 102921 | 29, 30, 31, 32, 33, 34, 46 |
| Screw, #8-32 x 3/8, PFH, CSK | 102809 | 22, 26, 29, 32, 35 |
| Screw, #8-32 x 3/8, PPHD, SEM, SS, Internal Tooth | 102922 | 47 |
| Screw, #8-32 x 3/8, Torx Security | 102748 | 35 |
| Screw, #8-32 x 1/2, Cap | 101666 | 22 |
| Screw, #10-32 x 1/2, SS, Hex | 101381 | 26 |
| Shield, Microwave | NGC-1116 | 39 |

| ITEM DESCRIPTION | PART NUMBER | FIGURE NUMBER (PAGES 65-78) |
|---|-------------|-----------------------------|
| Shim, 0.030 | NGC-1169-1 | 32 |
| Shim, 0.045 | NGC-1169-2 | 32 |
| Shim, Door Latch | NGC-1132 | 35 |
| Shim Tool, 0.030 | NGC-1344 | 32 |
| Shim Tool, 0.060 | NGC-1340 | 32 |
| Shunt Plate, Door | NGC-3021 | 35 |
| Smart Card, Blank | 100508 | 17 |
| Smart Card, Programmed (call TurboChef for Part Numbers) | Varied | 17 |
| Spacer, Aluminum, 1/2" | 101954 | 17 |
| Standoff, #8-32 F/F x 1" | 101912 | 31 |
| Standoff, #8-32, F/F x 1", 5/16 Diameter | 101914 | 33, 34 |
| Standoff, #8-32, M/F x 5/16", 1/4 Diameter | 101915 | 33, 34 |
| Stone, Baking, Fiber-Reinforced | NGC-3063 | 46 |
| Stone, Baking, Glazed, Clear | NGC-3038 | 46, 47 |
| Stone, Baking, Unglazed | NGC-3037 | 46 |
| Support, Frame | NGC-1047 | 22 |
| Switch, Door, Assembly | NGC-3033 | 29, 32 |
| Switch, Door (Component) | 102012 | 29, 30, 31, 32, 33, 34 |
| Tape, Aluminum | 102698 | 35 |
| Thermocouple, Electrical Compartment (EC) | 700-1199 | None |
| Thermocouple, Cook Cavity (CC) | NGC-1140 | None |
| Thermostat, High-Limit | 102075 | 38 |
| Thermostat, Magnetron | 102070 | 21 |
| Toggle, Latch | NGC-1073 | 30 |
| Transformer, Filament (USA, Korea) | NGC-3061-1 | 20 |
| Transformer, Filament (Europe, Asia-Pacific, Latin America) | NGC-3061-2 | 20 |
| Transformer, Filament (Japan) | NGC-3061-3 | 20 |
| Transformer, HV (USA, Latin America, Korea) | NGC-3062-1 | 20 |
| Transformer, HV (Europe, Asia-Pacific) | NGC-3062-2 | 20 |
| Transformer, HV (Japan) | NGC-3062-3 | 20 |
| Washer, Flat, #10 | 102140 | 26 |
| Washer, Shim | 102449 | 39 |
| Washer, Split Lock, #10 | 102350 | 26 |
| Wave Guide, Front | NGC-3016 | 20, 22 |
| Wave Guide, Rear | NGC-3017 | 20, 22 |
| Wire, Magnetron | 100186 | 21 |

For further information call:

800.90TURBO or
+1 214-379-6000



Part Number: **NGC-1007** / Revision G / August 2009
© 2009 TurboChef Technologies, Inc.

Global Operations

4240 International Parkway
Suite 105
Carrollton, Texas 75007
214.379.6000 PHONE
214.379.6085 FAX

turbochef.com