



NIKON METROLOGY SOLUTIONS



COORDINATE MEASURING MACHINES

CMM LASER SCANNING

HANDHELD LASER SCANNING

METROLOGY SOFTWARE

X-RAY AND CT INSPECTION

VISION MEASURING INSTRUMENTS

MEASURING MICROSCOPES

INDUSTRIAL MICROSCOPES

LARGE SCALE METROLOGY

METROLOGY SERVICES



**NIKON LC15Dx
CLOSING THE GAP
WITH TOUCH
PROBE ACCURACY**

p. 4 MULTI-SENSOR COORDINATE MEASURING MACHINES

Bridge CMMs
Gantry CMMs
Horizontal arm CMMs
LC series CMM-based line scanners
XC series multi-line Cross Scanners
Focus point cloud processing
Camio multi-sensor metrology software
CMM-Manager metrology software
MCAx – Manual CMM Arm
ModelMaker handheld scanners
K-Scan MMDx walk-around scanner

p. 19 X-RAY AND CT INSPECTION

XT H series industrial Computed Tomography systems
MCT 225 Metrology CT
XT V series electronics X-ray inspection

p. 25 MEASURING INSTRUMENTS

NEXIV VMZ video measuring system series
NEXIV VMR video measuring system series
iNEXIV VMA high-speed digital benchtop imaging system
MM series measuring microscopes
Profile projectors and optical comparators
Digimicro digital length measuring systems
Autocollimators

p. 32 INDUSTRIAL MICROSCOPES

IM series industrial microscopes
Stereoscopic Microscopes
BW-S50X White Light Interferometric Microscope system
NeoScope benchtop scanning electron microscope
ShuttlePix P-400R digital microscope
Vision measuring software

p. 38 METROLOGY ASSISTED PRODUCTIO

Laser Radar large volume inspection
iGPS/ iSpace large volume metrology, tracking
and positioning
Adaptive Robot Control
K-Robot in-line inspection

p. 43 NIKON METROLOGY SERVICES AND SUPPORT



MULTI-SENSOR COORDINATE MEASURING MACHINES

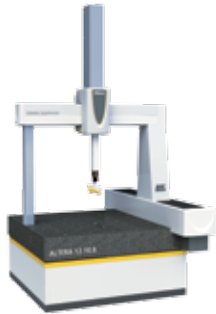

ALTERA



LK V-SL



LK V-R



LK H-R



LC15Dx



XC65Dx



MMDx



MCAx



K-Scan MMDx

Nikon Metrology laser scanning and point cloud solutions are key enablers of the Digital Inspection Process (DIP). Digital copies of prototypes, components and assemblies feed real-world information into today's digital design-through-manufacturing process.

COORDINATE MEASURING MACHINES

CMM LASER SCANNING

ARTICULATED ARMS

HANDHELD LASER SCANNING

METROLOGY SOFTWARE

ALTERA Bridge CMM

Excellence now and in the future...



ALTERA 10.10.8

Nikon Metrology's range of premium quality ALTERA CMM's meet the varying needs of manufacturers, both today and in the future. The superior ceramic design, with near perfect stiffness-to-weight ratio and greater resistance to temperature shifts, provides consistent performance across all manufacturing environments.

Standard packages, ESSENTIAL Series, OPTIMUM Series or ULTIMATE Series, offer three levels of popular functionality to suit a broad range of metrology applications, with additional options available to tailor your ALTERA CMM to your individual needs.

Features

- Flexible multi-sensor platform: touch probes, analog scanning and laser scanning
- High capacity (loads) table

Benefits

- Premium performance
- High velocities/accelerations for low cycle times
- Excellent accuracy and repeatability
- Total solution for probing, scanning and digital inspection

Applications

- Machined and pressed parts
- Plastic moldings
- Casting and forgings
- Touch trigger and non-contact inspection
- Digitizing, scanning and reverse engineering

Specifications

- Volumetric accuracy
 - from 1.8 μ m + L/400
- Repeatability
 - from 1.8 μ m
- Velocity
 - up to 43m/min
- Acceleration
 - up to 6824m/min²



Unique accuracy guarantee

Nikon Metrology is the only manufacturer to guarantee the accuracy of its CMMs for 10 years.

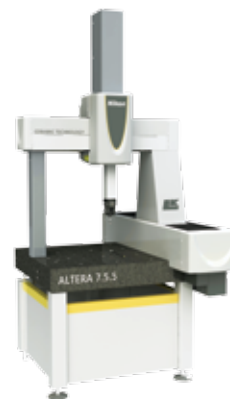

ALTERA 7.5.5 (box stand)

series ESSENTIAL

Touch trigger CMMs for general applications

series OPTIMUM

5-axis CMMs for complex internal geometry

series ULTIMATE

Multi-sensor CMMs for ultimate productivity and flexibility

ALTERA - Small bridge general-purpose CMM

Sizes (box stand)	Sizes ¹	Probe head	Sensors
7.5.5	15.7.6	MH20i	TP20
8.7.6	10.10.8	PH10T PLUS	TP200
10.7.6	12.10.8	PH10M PLUS	SP25M
	15.10.8	PH20	LC series laser scanners
	20.10.8		XC series laser scanners

¹ (other sizes available on request)

X-ray and CT Inspection

Measuring Instruments

Industrial Microscopes

Metrology Assisted Production

Services and Support

LK V Bridge and LK V HA High Accuracy CMM

High-performance ceramic bridge CMMs



LKV 15.12.10

LK's ceramic bridge and spindle components coupled with proven air-bearing design provide the ultimate in stiffness and stability, altogether delivering significantly improved repeatability.

Features

- Flexible multi-sensor platform: touch probes, analog scanning and laser scanning
- High capacity (loads) table

Benefits

- Premium performance
- High velocities/accelerations for low cycle times
- Excellent accuracy and repeatability
- Total solution for probing, scanning and digital inspection

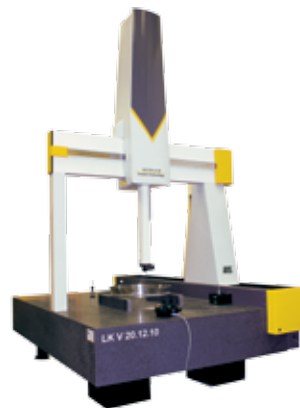

LKV 20.12.10

Applications

- Machined and pressed parts
- Plastic moldings
- Casting and forgings
- Touch trigger and non-contact inspection
- Digitizing, scanning and reverse engineering

Specifications

- Volumetric accuracy
 - from 2.1µm + L/375 (LK V)
 - from 1.5µm + L/350 (LK V HA)
- Repeatability
 - from 2.1µm (LK V)
 - from 1.5µm (LK V HA)
- Velocity
 - up to 37m/min (LK V)
 - up to 50m/min (LK V HA)
- Acceleration
 - up to 5900m/min² (LK V)
 - up to 5400m/min² (LK V HA)

LK V - Medium to large bridge general-purpose CMM

Sizes ¹				Probe head	Sensors
15.12.10	20.15.12	25.15.15	20.20.15	PH10MQ PLUS	TP20
20.12.10	25.15.12	30.15.15	30.20.15	PH20	TP200
25.12.12	30.15.12	35.15.15	35.20.15	SP80	SP25M
30.12.10	35.15.12	40.15.15	40.20.15	REVO	LC series laser scanners XC series laser scanners

LK V HA - Small to medium bridge high accuracy CMM

Sizes ¹				Probe head	Sensors
8.7.6	10.10.8			PH10MQ PLUS	TP20
10.7.6	15.10.8			PH20	TP200
	20.10.8			SP80	SP25M
	25.10.8			REVO	LC series laser scanners XC series laser scanners

¹ (other sizes available on request)

LK High-speed scanning bridge CMM

LK V-SL and LK V-SL HA offering ultimate scanning and inspection performance



LK V 10.10.8 SL equipped with an LC60Dx laser scanner

The LK V-SL features a revolutionary design that delivers the best scanning and inspection performance currently available in the marketplace. Particularly suited to meet the demands of automotive and aerospace applications, the LK V-SL is a unique and distinctive multi-sensor CMM. With the HA option, such a system becomes a metrology lab reference CMM featuring submicron accuracy for applications requiring highest precision.

Features

- Granite table with ceramic Y & Z guideways
- Raised X-axis guideway provides ultrafast dynamics
- S-axis 0.1 micron scale
- Multi-sensor capability
- Pneumatic anti-vibration mounts
- Temperature compensation as standard

Benefits

- Increased scanning performance delivering high accuracy and throughput
- Increased stiffness and stability of the metrology frame
- Ready for shop floor and metrology lab



LK V-SL (HA) metrology lab reference CMM

Applications

- Analog, digital or laser scanning
- Automotive, engine and transmission components
- Aerospace blade, engine and aircraft components
- General precision engineering
- Medical instruments

Specifications

- Volumetric accuracy
 - from 1.1 μ m+L/400 (LK V-SL)
 - from 0.7 μ m+L/600 (LK V-SL HA)
- Repeatability
 - from 0.7 μ m (LK V-SL)
 - from 0.5 μ m (LK V-SL HA)
- Velocity
 - up to 51m/min (LK V-SL)
 - 20m/min (LK V-SL HA)
- Acceleration
 - up to 5065m/min² (LK V-SL)
 - 722m/min² (LK V-SL HA)



Ceramics for LK PREMIUM performance

Stress-free ceramic guideways are most dimensionally stable, provide high and long-lasting measurement accuracy, and require minimum machine verification, saving both time and money.

LK V-SL and LK V-SL HA - High accuracy bridge style CMM

Preferred sizes ¹			Probe Head	Probes
8.7.6	10.10.8	20.12.10	PH10MQ PLUS	TP200
10.7.6	15.10.8			SP25M
15.7.6				LC15Dx, LC50Cx, LC60Dx, XC65Dx (-LS)

¹ (other sizes available on request)

LK V Large scale twin-rail mounted and gantry CMMs

A new breed of large scale CMMs



LK V 50.40.12 R



LK V-R twin-rail mounted bridge style CMM

Nikon Metrology offers large scale gantry and twin-rail mounted bridge style CMMs when size really matters. In addition to high accuracy with maximum volume, these large scale CMMs support a variety of probing solutions, including touch-trigger digital, analogue and laser options. Nikon Metrology also provides customized gantry CMM projects that meet customers' exacting requirements.

LK large scale CMMs are constructed using materials with high thermal stability to guarantee optimum accuracy.

Features

- High-performance air bearings
- LK CMMs feature granite rails with ceramic Y and Z guideways
- Supports tactile styli, analogue scanning and laser scanners

Benefits

- Ceramic material offering 300% more stiffness over aluminium allows for ultra large machine sizes with premium accuracy
- Floor-mounted or raised gantry versions to suit all environments and component handling situations
- Twin drive systems valued for smooth motion
- Available with separate measuring plate if required

Applications

- Automotive and commercial vehicles
- Aerospace components and structures
- Marine and locomotive engine components
- Telecommunications and satellite equipment

Specifications

- Volumetric accuracy
 - from 4.5µm + L/200 (LK V-R)
 - from 3.5µm + L/250 (LK V-G(P))
- Repeatability
 - from 4.5µm (LK V-R)
 - from 3.5µm (LK V-G(P))
- Velocity
 - up to 32m/min (LK V-R)
 - up to 27m/min (LK V-G(P))
- Acceleration
 - up to 2270m/min² (LK V-R)
 - up to 2070m/min² (LK V-G(P))

LK V-R and LK V R-SL - Twin-rail mounted bridge style CMM

(short-leg models available)

Sizes ¹	Probe Head	Probes
Rail lengths from 3m to 10m+	PH10MQ PLUS	TP20
Bridge sizes from 2m to 4m		TP200
Spindle lengths from 1.2m to 3m <i>(short-leg model with steel legs or concrete riser foundation)</i>		SP25M LC15Dx, LC50Cx, LC60Dx, XC65Dx (-LS)

LK V-G(P) - High accuracy and ultra high accuracy bridge style CMM

Sizes ¹	Probe Head	Probes
Rail lengths from 2m to 10m+	PH10MQ PLUS	TP20
Bridge sizes from 4m to 7m		TP200
Spindle lengths from 3m to 4m <i>(available with steel legs or concrete riser foundation)</i>		SP25M LC15Dx, LC50Cx, LC60Dx, XC65Dx (-LS)

¹ (other sizes available on request)

LK H Horizontal arm CMM

The fastest high accuracy horizontal arm CMMs on the market



LK H-R premium series twin-rail mounted horizontal arm CMM with walk-on covers

Nikon Metrology's complete range of horizontal arm CMMs provides unequalled performance in speed, accuracy and repeatability. Ceramic guideways and air bearings used in the construction of LK H CMMs, offer stability at high velocity and acceleration. LK horizontal arm CMMs provide unique access to the measuring envelope and can be supplied as subfloor or floor level installations, or as part of fully-automated measurement cells.

Features

- Multiple CMM configurations available: table, rail, twin, etc.
- Supports laser scanners and touch sensors
- Can be supplied with cast-iron measuring plate if required

Benefits

- High velocities/acceleration for low cycle times
- Excellent accuracy and repeatability
- Flexible multi-sensor platform: touch probes, analog scanning, laser scanning



LK H-R dual column horizontal arm CMM



LK H-T high accuracy table mounted horizontal arm CMM



LK H-T featuring rotating table

Applications

- Automotive full body and panels inspection
- Inspection of large parts such as mold tools, housings, castings, etc.
- Integrated in-line inspection
- Touch trigger and non-contact inspection
- Digitizing, scanning and reverse engineering

Specifications

- Volumetric accuracy
 - from 1.9µm + L/250 (LK H-T)
 - from 10µm + L/200 (LK H-R)
- Repeatability
 - from 1.9µm (LK H-T)
 - 6.0µm (LK H-R)
- Velocity
 - up to 51m/min (LK H-T)
 - up to 40m/min (LK H-R)
- Acceleration
 - up to 10830m/min² (LK H-T)
 - up to 7580m/min² (LK H-R)

LK H-R - high accuracy rail mounted horizontal arm style CMM (single or twin column)

Sizes ¹	Probe Head	Probes
Rail lengths from 4m to 10m+	PH10MQ PLUS	TP7M
Spindle lengths from 0.4m to 1.6m		TP20
Column heights from 2m to 3m		TP200B
<i>(available with walk-on or bellow covers for rails)</i>		SP25M
		LC15Dx, LC50Cx, LC60Dx, XC65Dx (-LS)

LK H-T - high accuracy table mounted horizontal arm style CMM

Sizes ¹	Probe Head	Probes
Rail lengths from 1m to 5m	PH10MQ PLUS	TP20
Spindle lengths from 0.4m to 1.6m		TP200B
Column heights from 0.6m to 2m		SP25M
		LC15Dx, LC50Cx, LC60Dx, XC65Dx (-LS)

¹ (other sizes available on request)

LC60Dx/LC50Cx/LC15Dx Line scanners

Digital laser scanning boosts inspection performance



Applications

Inspection and reverse engineering of mobile phones, turbine blades, tools, castings, dies, sheet metal parts, plastics, etc.

Specifications

	LC15Dx	LC60Dx	LC50Cx
Field of View	18x15mm	60x60mm	50x60mm
Probing error (MPE _v) ¹	2.5µm	9µm	20µm
Data acquisition (approx. pts/sec)	70,000	77,000	37,500
Enhanced Scanner Performance (ESP3)	√	√	√

¹ Nikon Metrology test comparable to EN/ISO 10360-2

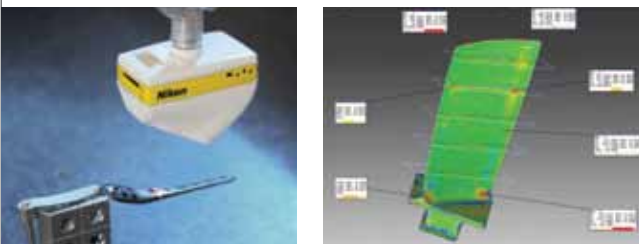

LC15Dx is suited for inspection of complex parts with tight tolerances, e.g. medical implants, turbine blades and precision mouldings

The all-digital Nikon LC15Dx scanner brings 3D digitizing in the accuracy range of tactile measurement, while offering the advantage of capturing a multitude of inspection points. With its smaller field of view, it perfectly suits digitizing small or detailed objects with higher point density and tighter tolerances

The LC60Dx is an all-purpose scanner that can be used both on CMM and portable arms. The LC50Cx laser scanner offers an adequate productivity with its 50mm stripe width and scanning rate of 45 stripes per second.

Equipped with state-of-the-art CMOS technology and powerful on-board data processing, the digital LC scanners more than triple today's common scan rates. This enables manufacturers to drastically reduce the inspection cycle time for freeform parts, or boost the number of features that can be inspected in the same time frame.

To effectively scan surfaces with varying color or high reflectivity, LC scanners provide automatic real-time adjustment (ESP3) of sensor settings for each individual point of the laser stripe.

Features

- Fully compatible with Renishaw PH10M(Q) PLUS and automatic change racks (ACR)
- Data collection over multi-wire is integrated into most CMM brands and types
- Designed for minimum warm-up time and maximum operational stability and robustness



LC60Dx



LC50Cx

BENEFITS OF CMM-BASED LASER

- Simplified measurement and processing setup
 - Teach scan paths or indicate scan area on CAD
 - Import feature properties and GD&T information directly from CAD
 - Macro functionality for fully automated scanning and inspection
- Reduced measurement time
 - Reduction of probe head movements
 - XC65Dx(-LS) scanner captures full feature information in a single movement

XC65Dx(-LS) Cross Scanner

Full 3D capture of complex features and surfaces



Applications

- Inspection sheet metal features (slots, holes, etc.)
- Inspection of castings and complex surfaces
- Feature inspection
- Gap & flush inspection

Incorporating 3 lasers in a cross pattern, the XC65Dx captures all full 3D details of features, edges, pockets, ribs and freeform surfaces in a single scan. By digitizing complex features from 3 sides, the Cross Scanner acquires the complete 3D geometry of the features, driving the accurate extraction of positions and dimensions.

The Cross Scanner's entirely digital operation boosts scanning frequency and drives intelligent laser intensity adaptation to scan any surface without user interaction.

Features

- Cross-pattern of 3 lasers to obtain full 3D view in one scan
- Drastically reduces time-consuming probe head indexing and eliminates C-axis
- Fast digital scanner operation including high-speed CMOS camera technology
- XC65Dx-LS longer stand-off variant for optimum capture of deep pockets and slots
- Accuracy $9\mu\text{m}$ for XC65Dx(-LS) in multi-stylus test comparable to EN/ISO 10360-5 MPE_{al}



The XC65Dx is the scanner of choice for car body inspection.



The scanner's high field of view depth results in major time savings when inspecting automotive cast parts.

X-ray and CT Inspection

Measuring Instruments

Industrial Microscopes

Metrology Assisted Production

Services and Support

SCANNING

- Unique capability to measure freeform and fragile surfaces
 - Detailed description of freeform surfaces in short time interval
 - Non-contact measurement eliminates the need to touch fragile and delicate parts
 - Powerful reporting with colored CAD deviation maps
 - Input for reverse engineering, rapid prototyping, finite element calculations, and digital archiving

Focus point cloud software

Focus 10 – Streamlining laser scanning based portable and CMM inspection

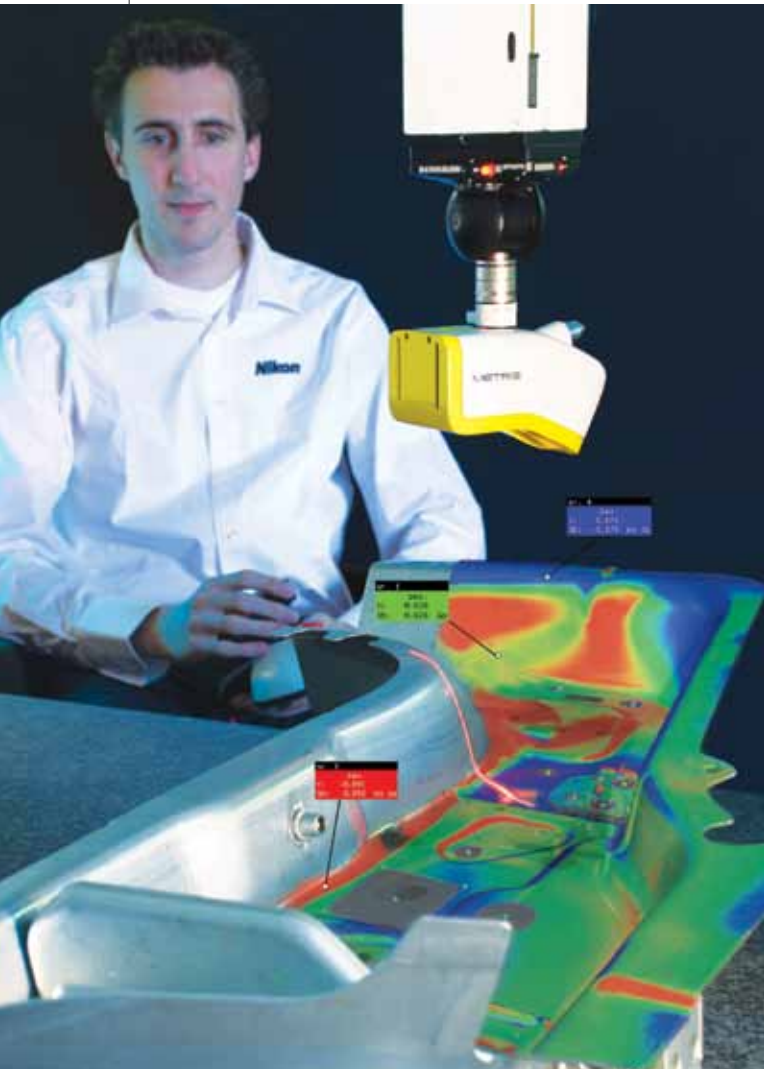

Focus 10 is today's reference for integrated point cloud acquisition and inspection. The software offers stunning performance, offers an intuitive user-interface and standard macro functionality to automate the entire inspection process.

Focus 10 provides feature and full part-to-CAD 3D inspection, starting from point cloud data or meshes from CMM scanners, handheld scanners or Computed Tomography (CT). Focus 10 visualizes inspection results in easy-to-interpret, interactive graphics and reports.

Features

- Superior point clouding handling
 - Up to 100 million points
 - Powerful and automated feature detection algorithms
 - Automatic processing of scan data into an accurate, high quality polygon mesh
- Full inspection toolbox
 - Full part comparison to CAD or STL
 - Complete set of 2D and 3D features
 - GD&T (Geometric Dimensioning & Tolerancing)
 - Wall thickness, flush & gap, and directional comparison
- Flexible reporting and data sharing
- All inspection functions fully automatable
- Dedicated inspection modules (e.g. Turbine Blade Inspection)

Benefits

- High productivity and data consistency with minimum effort
- Reduces throughput time for both surface and feature inspection
- Controls acquisition from CMM or portable CMMs (articulated arms, Optical CMM)
- Designed for industrial use by operators and engineers
- Inspection automation without requiring programming skills
- Easy-to-interpret and interactive reporting to facilitate decision making

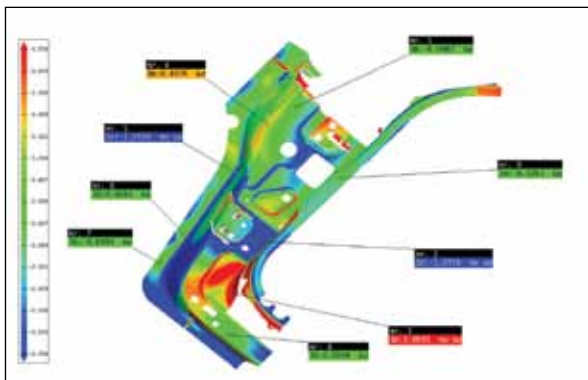

Color map reports clearly indicate local geometry deviations

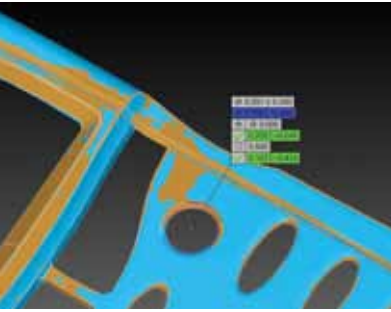

Geometric dimensioning & tolerancing (GD&T)

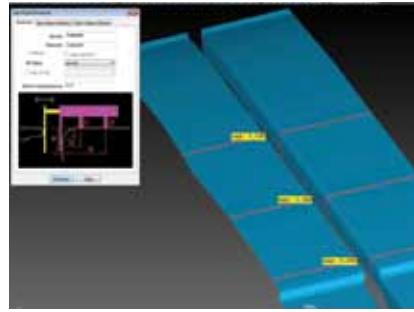

Gap & flush analysis

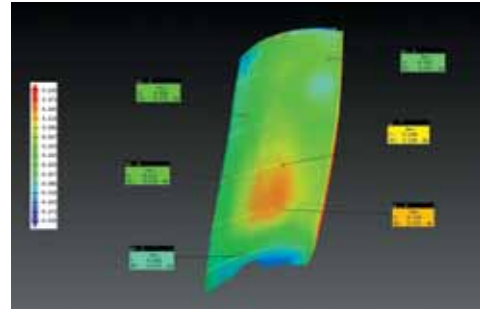

Turbine blade inspection

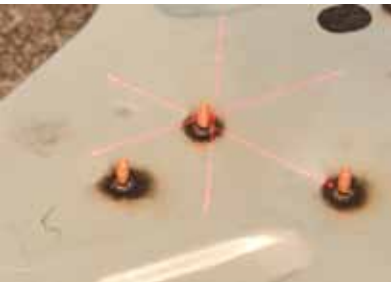

Inspection of features in automotive applications...

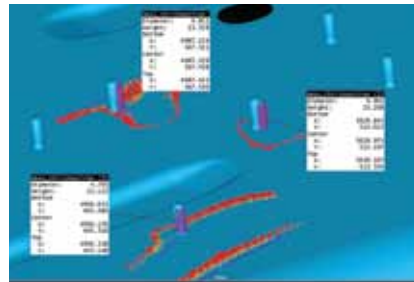

...are readily compared to CAD in Focus Inspection

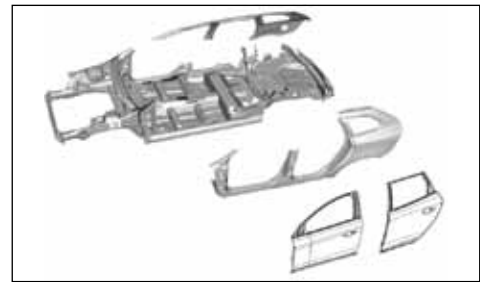

Virtual assembly allows measured and CAD models to be built together to predict mating conflicts

Focus Scan – Fast, easy and accurate data capture for CMM and portable laser scanning

Focus Scan is the driver software for Nikon Metrology laser scanner integrations on CMMs, articulated arms and Optical CMMs. It acquires and pre-processes the raw point cloud data and particularly for CMM based scanning, it provides off-line and on-line scanner path definition. cloud data. The off-line CMM scanning module enables users to create, modify and prove out part programs using 3D CAD models, allowing CMMs to be used exclusively for measurement. The software is seamlessly integrated with Focus' inspection, automation and reporting functions.

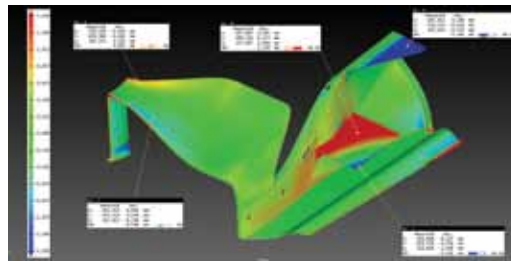

Besides requiring simpler scanner motion paths, automatic scan path programming further reduces measurement preparation time.

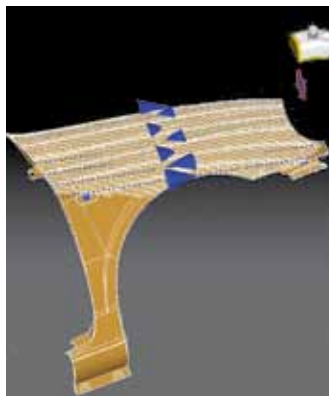

A breakthrough in validating scan macros is the new point spray feature that simulates a point cloud as if the part is measured on the CMM.

CAMIO7 Multi-sensor CMM metrology software

The standard for DMIS coordinate measuring machine programming

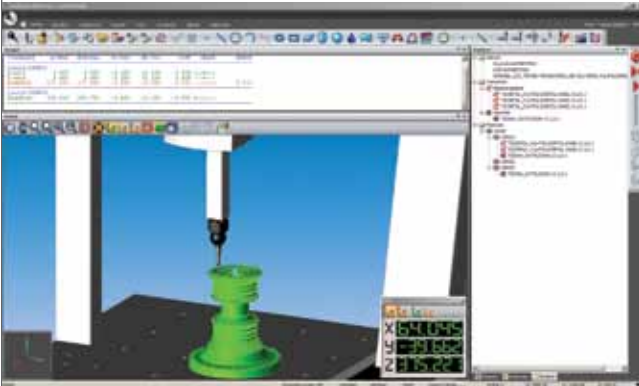

NEW CAMIO7 interface developed for ease of use based on powerful programming functions

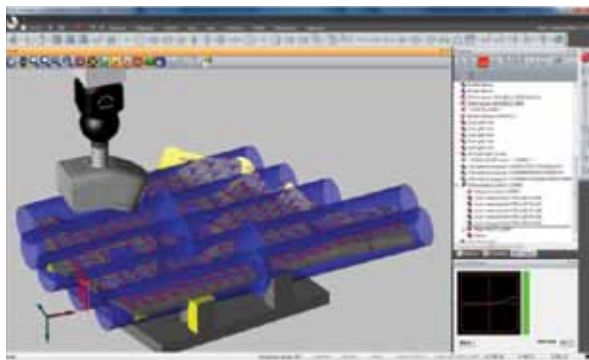

Laser scanner paths can be programmed based on CAD data or taught from the hand-box

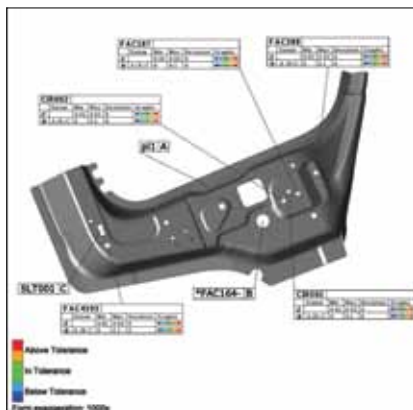

Integrated graphical reporting

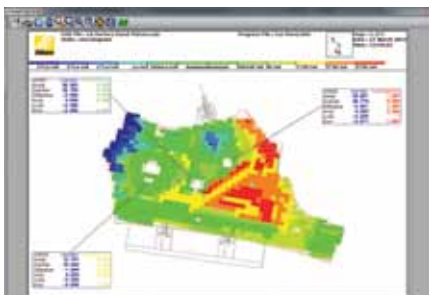

Graphical reporting combining GD&T tolerances and full part to CAD comparison

CAMIO7 is the world's leading multi-sensor CMM programming software supporting traditional touch-trigger probes, continuous contact scanning probes and the full range of Nikon laser scanning probes.

Regardless of whether inspecting stamped, moulded, fabricated or machined parts CAMIO7 drives accurate and efficient inspection programs for geometric features or full surface analysis with CAD compare.

Features

- An interface reflecting the latest Microsoft® Windows® standard with ribbon style toolbars providing instant access to all programming functions.
- Simple programming environment optimized for a minimum number of mouse-clicks.
- Fast workflow to program multiple features of multiple types (ie points, circles etc.) in a single operation.
- Structured and comprehensible probe management.
- Probe check function to verify the probe path before committing to the program or CMM operation.
- Flexible reporting options with multiple outputs including full colour graphics, ASCII text, excel or internet browser compatible formats.
- Support for the latest versions of CAD data: IGES, VDA-FS, STEP, ACIS®, CATIA® v4 and v5, Pro/ENGINEER®, Unigraphics®, Solidworks® and Parasolids®.
- Fully I++ compliant.

Benefits

- The ability to create CMM programs using multiple probe types to achieve the best CMM inspection routine for your application.
- Easy to use programming functions to suit all levels of user.
- Reduced programming time.

Comprehensive off-line programming capability

- CAMIO7 planning provides the capability create new or open existing inspection plans direct from CAD data including the import of part axis and GD&T tolerance data.
- Full machine simulation and collision avoidance.
- Creates CMM programs in true DMIS output without translation.
- CAMIO7 can be used as a stand-alone solution to create programs to run in compatible 3rd party DMIS software* including PC-DMIS® and Metrolog XG®.

Related solutions

- Bridge, horizontal arm and gantry CMMs
- LC/XC scanners

* compatibility check to the DMIS standard is advised

CMM-Manager metrology software

A full-featured metrology software for manual, CNC and portable CMMs

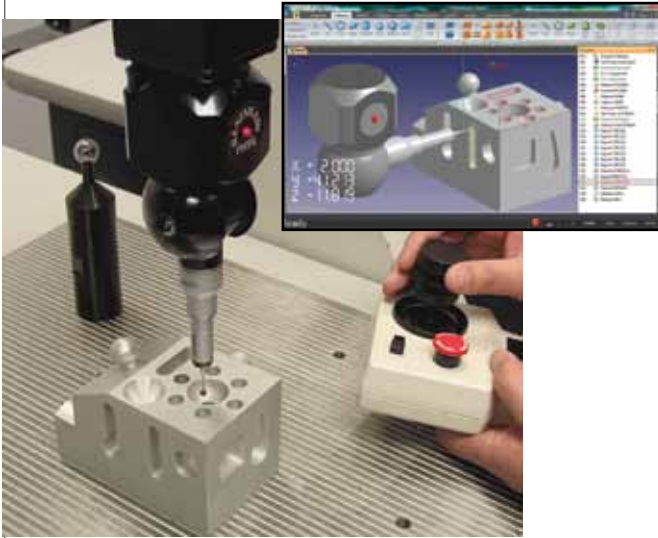

CMM-Manager for Windows is by far the most value-for-money tactile inspection software that runs on nearly all manual, CNC and portable CMMs. Users accomplish more in less time with CMM-Manager, by automating serial inspection or by easily taking a few points on the spot.

It is a task-oriented, highly intuitive software featuring quick walk-in measurement, one-click CAD measure, collision-free CAD teach, virtual simulation, real-time verification, CAD and datum alignment, and many more smart functions. CMM-Manager's Windows 7 graphical user interface makes the software even more informative and interactive.

Features

- CAD based graphical programming
- Automatic collision avoidance
- Smart alignment features
- Automatic probe recognition
- Leap frogging to extend measurement volume for portable measurement
- Best-fit analysis for improved inspection accuracy
- Drag and Drop web-ready graphical reporting

Benefits

- Focus on quick and accurate measurement results
- Easy to use, yet very complete metrology software
- Single software package for CNC, manual and portable measurement

Retrofit capabilities

- CNC or Manual CMM: Nikon Metrology, Sheffield, Mitutoyo, Brown & Sharpe, DEA, Zeiss, Starrett, Numerex, Helmel, Wenzel, Renishaw
- Portable CMM retrofits: MCA, K-Series Optical CMM, Faro, Romer/CimCore, Sheffield, Brown & Sharpe, Mitutoyo, Renishaw

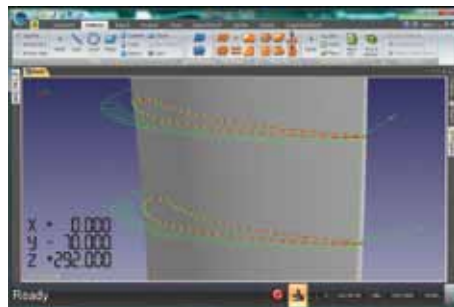
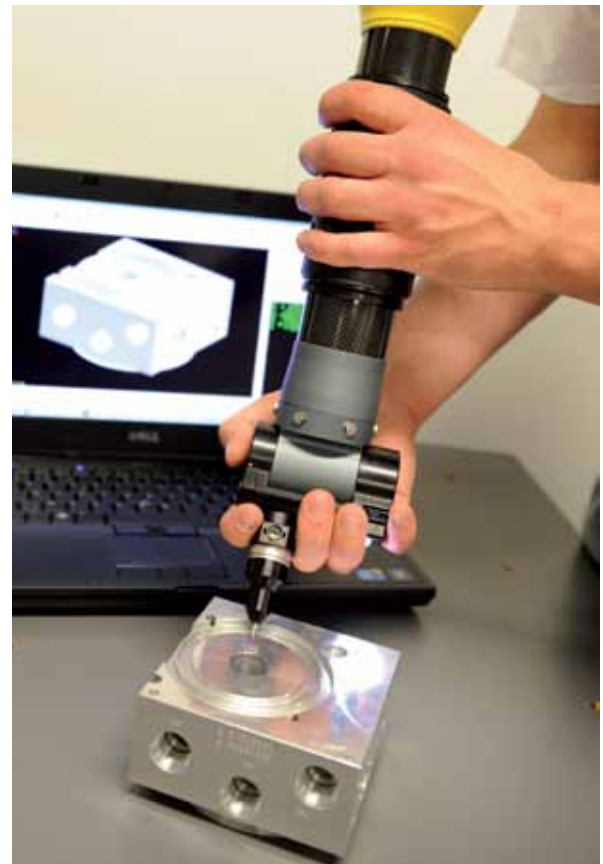

Easy-to-use software capable of measuring complex parts

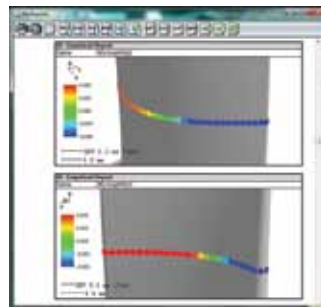

Quick data interpretation through color-coded local geometry deviation

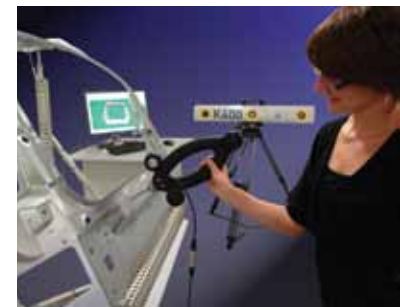

K-Series Optical CMM with SpaceProbe for large volume measurements

X-ray and CT Inspection

Measuring Instruments

Industrial Microscopes

Metrology Assisted Production

Services and Support

MCAX - Premium portable metrology

The perfect companion for ModelMaker handheld scanners



The MCAX Manual Coordinate measuring Arm, is a precise, reliable and easy-to-use portable 7-axis measuring system. It is the perfect partner for the ModelMaker MMDx / MMCx digital handheld laser scanners and Focus 10 Handheld scanning and inspection software. This total solution's accuracy, capability and portability makes it feel perfectly at home in the metrology lab, on the shop floor and in-the-field.

The MCAX arm can be equipped with a wide range of probing systems for laser scanning, touch-trigger measurements and continuous scanning. Its flexibility makes this measurement arm the perfect solution for the widest range of measurement tasks.

Features

- Flexible probing options
- Intuitive scanning and inspection software
- Available in 6 lengths between 2.0m and 4.5m
- Advanced construction: aerospace-grade carbon fiber arm tubes are strong, lightweight, thermally stable and feature a lifetime warranty
- Infinite rotation of all principle axes for unrestricted use
- Feature packs provide additional capability such as Wireless (Wi-Fi) connectivity and Li-Ion battery power

Applications

- Full part-to-CAD inspection
- Feature inspection
- Flush & gap inspection
- On-site troubleshooting
- Solving assembly problems
- Data collection for reverse engineering

Related solutions

- ModelMaker laser scanners
- LC60Dx laser scanners
- Focus software

Benefits

- High accuracy and fast data throughput saves time and money
- Optimized for hard-to-scan surfaces
- Designed for use under all shop floor or field conditions
- Quick and easy plug-and-play setup
 - Short learning curve
 - No external controller
 - Automatic probe recognition
- Enhanced ergonomics mean stress-free usage
- Extreme temperature stability and zero warm-up time
- Scanner compatible with all major brands of portable localizers and point cloud software



ModelMaker MMDx/MMCx

Intuitive scanning and one-click analysis



The ModelMaker handheld laser scanners are ideally suited for portable 3D inspection and reverse engineering applications. MMDx camera technology is a major leap forward in 3D laser scanning, as it introduces high frame rate and a large stripe width up to 200mm for ultra-productive scanning. MMDx/MMCx incorporates Enhanced Sensor Performance (ESP3) to scan all sample materials and surface finishes in a single move.

The digital camera benefits from a true non-interpolated resolution of more than a thousand points per stripe, providing optimum resolution for efficient scanning of freeform surfaces and features. ModelMaker is compatible with MCA, MCA II and MCAx series and many 3rd party articulated arms in addition to the K-Series Optical CMM system.

Features

- Multiple stripe widths available from 50 to 200mm
- Accuracy down to 10µm (1σ)
- Enhanced Sensor Performance for scanning materials with varying surface materials and reflectivity
- Out-of-the-box scanning with direct plug into PC
- Focus software for handheld 3D laser scanning
 - Real-time rendered scan visualization
 - Localizer-driven scanning menu
 - Mesh creation and processing
 - Part-to-CAD comparison

Benefits

- Ergonomic solution thanks to lightweight housing and full scanner control at your fingertips
- Superior scanning accuracy for freeform and feature inspection
- High scanning throughput through fast digital data capture
- Robust design for use under all shopfloor conditions

Applications

- Part-to-CAD inspection
- Inspection of geometric features
- Gap & flush inspection
- Reverse engineering – from concept studio clay to class A surfaces
- Input for rapid prototyping

Related solutions

- MCAx articulated measuring arms
- K-Series Optical CMM
- Focus point cloud processing software



MMDx scanner is available in 50/100/200mm stripe width and MMCx features a 80/160mm stripe width

K-Scan MMDx

Walk-around scanning in large work volumes



K-Scan MMDx is a handheld walk-around laser scanner for portable metrology applications in a large work volume. Continuous and precise probe tracking through the system's Optical CMM and 20 infrared markers integrated into the laser scanner device eliminate all mechanical constraints for effortless scanning.

Accurate performance and superior ergonomics make K-Scan MMDx a user-friendly handheld scanning solution. K-Scan MMDx is the ideal tool for accurate part-to-CAD inspection and productive reverse engineering of large components. Dynamic referencing guarantees consistent measurement results even when the camera or the measurement object moves during scanning.

Features

- Measuring volume of 17m³ expandable by adding more cameras
- Stripe width between 100 to 200mm (depending on the selected scanner type)
- Lightweight carbon fiber probe design
- Dynamic referencing to measure instable or moving parts
- SpaceProbe available for tactile measurements

Benefits

- Measure anywhere
- Effortless handling through probe tracking and ergonomic design
- High scanning throughput and superior accuracy
- Multi-camera setup enlarges work volume to capture complete car or truck

Applications

- Full surface and feature inspection of larger parts
- Flush & gap inspection
- On-site troubleshooting
- Solving assembly problems

Related solutions

- K-Series Optical CMM
- SpaceProbe
- Focus point cloud processing software

K-Series Optical CMM

Through triangulation, K-Series' linear CCD cameras dynamically measure the position of infrared markers integrated into the ergonomic handheld ModelMaker laser scanner or SpaceProbe device.



X-RAY AND CT INSPECTION



Get the inside picture of complex electronics or industrial parts, by literally looking into the internal structure. Then use CT capability to qualify and quantify any inner or outer dimension, all in a smooth, non-destructive process.

XT H 450 HIGH-POWER CT SCANNING

XT H 225 INDUSTRIAL CT SCANNING

MCT225 METROLOGY CT

XT V 130C ELECTRONICS X-RAY INSPECTION

XT V 160 ELECTRONICS X-RAY INSPECTION

XT H 225 industrial CT scanning

Full inner and outer inspection of industrial components



Detailed capture and measurement of internal component and assembly features is often vital for quality control, failure analysis and material research. XT H 225 offers a powerful micro-focus X-ray source, a large inspection volume, and high X-ray and CT imaging resolution. XT H 225 suits a wide range of applications, including inspection of small castings, plastic parts as well as material research.

Applications

- Evaluation and measurement of precision plastic parts and small castings, complex mechanisms, internal components, part-to-CAD comparison, etc.
- Detailed failure analysis
- Advanced material research and analysis of biological structures
- Digital archiving of models
- Troubleshooting of assembly issues

Related solutions

- XT H ST (Stretched) and XT H LC (Large Cabinet)
- Source variations
 - 160kV Reflection target
 - 180kV Transmission target
 - 225kV Rotating target
 - 320kV Reflection target
- Inspect-X software
- Focus Inspection software
- A wide range of customer-specific CT configurations can be provided

Features

- Powerful 225kV micro-focus source with optional rotating target
- Real-time X-ray visualization, fast CT reconstruction
- CT measuring volume up to 250mm and 600mm height
- 5-axis fully programmable part manipulator
- Customizable macros automate measurement workflow
- Small footprint and castors & roller for easy handling

Benefits

- Flexibility combined in a single system: X-ray for quick visual inspection, CT for in-depth analysis
- Fast data capture and high-quality images
- Fast operation with interactive joystick navigation
- High-resolution digital imaging and processing
- Safe system requiring no special precautions or badges
- Tight integration with industry standard post-processing applications



XT H 225 ST



XT H 225/320 LC

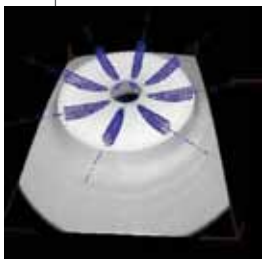

Cylinders fitted in holes

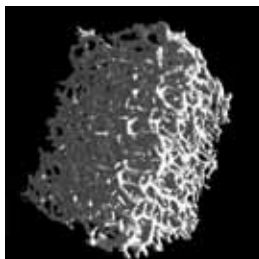

CT of foam structure

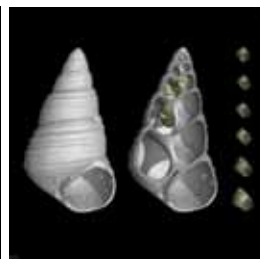

Snail fossile with offspring



An X-ray source with rotating target boosts X-ray flux by up to 5 times, enabling customers to obtain faster CT data acquisition or achieve higher CT data accuracy in the same time span.

XT H 450 for CT inspection of blades and castings

High power 450kV micro-focus source



The XT H 450 sets a new reference for turbine blade measurement and NDT of small to medium castings. At the core of this powerful equipment is a 450kV micro-focus source, providing superior resolution and accuracy.

The curved linear array detector optimizes the collection of X-rays by eliminating scatter phenomena that typically corrupt 2D radiographs of blades and other metal parts.

Features

- Unique open-tube 450kV micro-focus source
- High-brilliance source available (option) source
- Different maging options
 - Perkin Elmer flat panel detector (XT H 450 3D)
 - Curved Linear array Detector (XT 450 2D)
 - Combination of plat panel and CLAD
- Measuring volume up to 600mm diameter and 600mm height
- 5-axis fully programmable turntable manipulator with precision ball screws and linear slides
- Dedicated application for automatic pass/fail inspection of turbine blades

Applications

- Detailed analysis of the wall thickness and internal structure of turbine blades
- Automated pass/fail inspection of blades
- Inspection of high density parts (e.g metal parts, castings) with a need for micron accuracy

Faster throughput or higher data quality with high-brilliance source

The new (optional) 450kV high-brilliance source enables the user to get the most out of this XT H 450 system. For a given spot size and power, data can be collected typically 3-5x faster, giving the user faster throughput. Alternatively for a given power and measurement time, the available resolution will be higher and so the data quality will be improved. The high-brilliance source also delivers continuous 450W without measurement time restriction.



The 450kV high-brilliance source provides the same advantages as a rotating target source: faster data collection or a higher data quality at continuous power

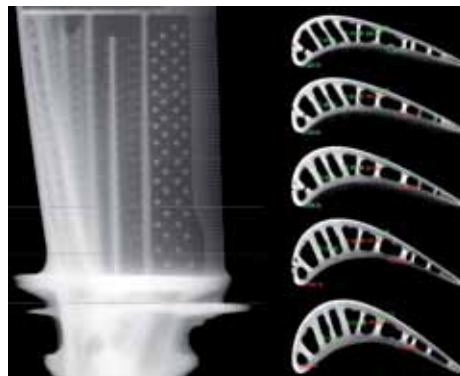

X-ray image and CT slices of a single-crystal aerospace turbine blade generated using an XT H 450 system equipped with a Curved linear diode array (CLDA) detector.

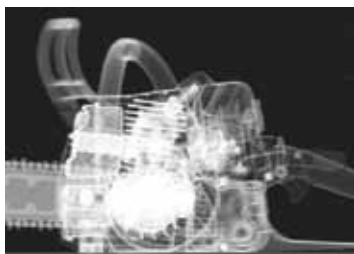

X-ray of chainsaw

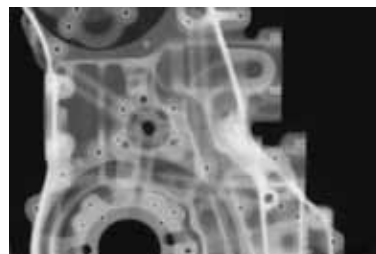

X-ray of engine casting

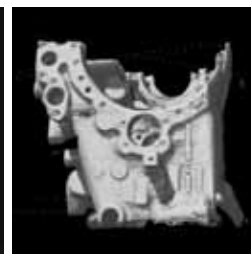

CT volume model of engine casting

MCT225 – Metrology CT

Absolute accuracy for inside metrology



MCT225 provides Metrology CT for a wide range of sample sizes and material densities in accordance with the latest industry standards. All internal and external geometry is measured efficiently without reference measurements and damaging the sample. With fifty years' CMM experience and twenty five years' X-ray experience, our pedigree for reliable high quality Metrology CT is second to none.

Absolute accuracy

MCT225 is pre-calibrated using accuracy standards traceable to the UK's national measurement institute (NPL) and verified using VDI/VDE 2630 guidelines for Computed Tomography in Dimensional Measurement. Absolute Accuracy guarantees measurement accuracy without time consuming comparative scans or reference measurements, samples are simply placed on a rotary table inside the enclosure and measured. Several key metrology features provide long term stability and enable the MCT225 to achieve an impressive accuracy specification of $9+L/50\mu\text{m}$.

Applications

Internal/External geometry inspection of:

- Plastic injection-moldings
- Metal die-casting
- Complex parts and assemblies

MATERIAL PENETRATION GUIDE

PLASTIC	170mm (6.7")
ALUMINIUM	75mm (2.9")
IRON	15mm (0.6")

Other suitable materials include:
STEEL, CERAMIC, CARBON FIBRE, WOOD

Features

- Nikon Metrology developed micro-focus X-ray source
- Temperature controlled enclosure
- High precision linear guideways
- Axis travels error corrected
- Liquid cooled X-ray source
- High resolution optical encoders
- High resolution 4Megapixel detector
- Finite Element Analysis (FEA) optimized manipulator

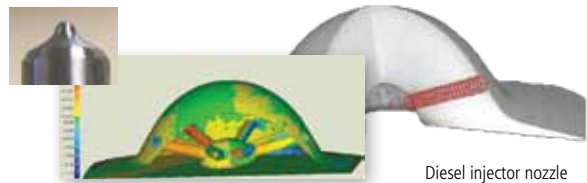

Metrology CT process



F1 car hydraulic manifold

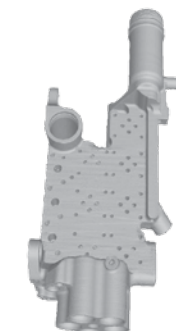

▶ CT volume reconstruction

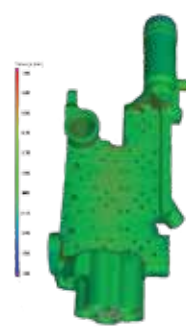

▶ Direct comparison to CAD model

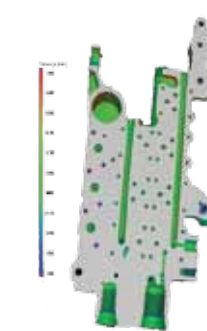

▶ Section of internal geometry

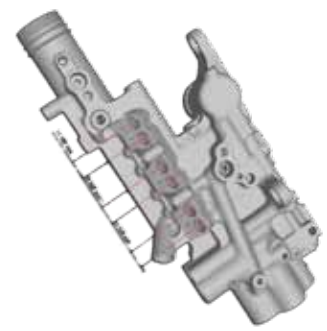

▶ Dimensional report GD&T

XT V 130C electronics X-ray inspection

Versatile and easy-to-use electronics QA system



The XT V 130C is a highly flexible and cost-effective electronics and semiconductor inspection system. The system features a 130kV/10 watt Nikon Metrology manufactured source, a globally recognized open tube design with integrated generator, and a high-resolution imaging chain.

Through a series of factory and field upgrades, the end-user can configure these systems to its own needs with a higher power source, a rotating sample tray, automatic inspection software, a digital flat panel option, and the ability to add future-proof CT technology.

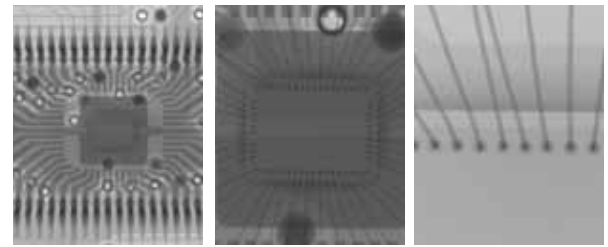

Superb image magnification enables users to zoom in on any specific item of interest

Applications

- Electronic and electrical components
 - Broken wedge bonds, lifted ball bonds, wire sweep, die attach, dry joints, bridging/shorts, voiding, BGA, etc.
- Poulated and unpopulated PCBs
 - View surface mount defects i.e. misaligned devices, solder joint porosity and bridging
 - Detailed inspection of vias, through-hole plating and multi-layer alignment
 - Wafer-level chip scale packages (WLCSP)
 - BGA and CSP inspection
 - Non-lead solder inspection
- Micro-electro-mechanical systems (MEMS, MOEMS)
- Cables, harnesses, plastics and many more

Related solutions

- XT V 160
- Inspect-X



Large door with automatic interlocked X-ray off function

Features

- Proprietary 20-130kV micro-focus source with 2 μ m feature recognition
- Measurement area of 406x406mm
- True 75° manipulator tilting angle allows oblique viewing for easy inspection of internal features
- A hinged door providing easy access to the inspection area
- Serviceable components are easily accessible

Benefits

- On-line operation with intuitive joystick navigation
- Low-cost maintenance with open-tube technology
- Safe system requiring no special precautions or batches
- Small footprint and low-weight for easy installation
- CT option possible

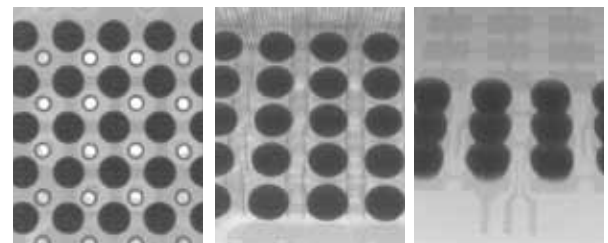

Tilt angle up to 75° offers sufficient flexibility to trace connectivity issues quickly

XT V 160 electronics X-ray inspection

Top-class inspection system for miniaturized electronic components



Component connections on today's compact and densely populated PCBs are hidden by other components, making X-ray the only viable inspection solution. XT V 160 is an easy-to-use, cost-effective and high-quality PCB inspection system targeting production facilities and failure analysis laboratories.

In automated inspection mode, samples can be inspected at the highest throughput. In manual mode, intuitive software and high-precision sample manipulation enable operators to visualize and evaluate the tiniest internal defects and deficiencies.

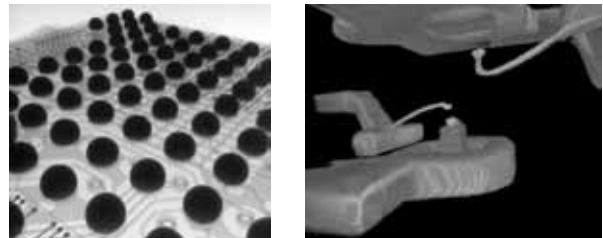

Related solutions

- XT V 130
- Inspect-X

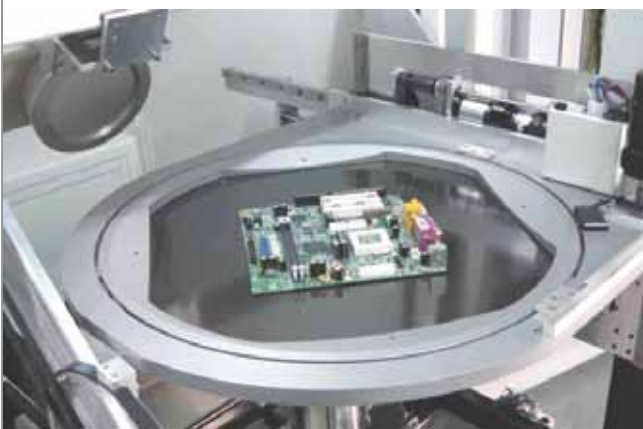

Under any combination of rotation, tilt and magnification, the region of interest is consistently locked into the center of the field of view

Features

- NanoTech™ source with submicron focal spot size
- True 75° tilting angle for optimum inspection of BGAs
- Fast data capture and high-quality imaging
- Large tray for loading multiple boards
- Customizable macros automate measurement workflow
- Remote validation station available

Benefits

- Flexibility combined in one system
 - Interactive visualization
 - Fully automatic X-ray inspection
 - Optional CT for in-depth analysis
- Maximum magnification at unrivalled angles (up to 75°)
- Fast operation with intuitive GUI and interactive joystick navigation
- Low-cost maintenance with open-tube technology
- Safe system requiring no special precautions or badges
- Small footprint

Applications

- Solder reflow analysis
- BGA connectivity and analysis
- Solder void calculation
- Through hole measurement and inspection
- Die attach voiding measurement
- Ball bond analysis
- Stitch bond analysis
- Micro BGA / chip on chop analysis
- Pad array analysis
- Dry joint detection and analysis

MEASURING INSTRUMENTS



Precision metrology instruments ensure the finest quality assurance throughout production. Founded on Nikon's optical excellence, video measuring systems, measuring microscopes, profile projectors and optical comparators set new standards for measuring even the smallest of work pieces.

VIDEO MEASURING SYSTEMS

MEASURING MICROSCOPES

PROFILE PROJECTORS

DIGITAL HEIGHT GAUGES

AUTOCOLLIMATORS

Multi-Sensor Coordinate
Measuring Machines

X-ray and CT Insight

Measuring Instruments

Industrial Microscopes

Metrology Assisted
Production

Services and Support

Nexiv VMZ-R4540 CNC Video Measuring System

Incorporating the latest advancements in NEXIV technology



Features

- High rate of data transfer combined with fast illumination control provide faster throughput
- New Laser Auto Focus designed to detect surface of thin transparent material
- 4 types of optical zoom systems
- New 8-sector Ring Light system with three incident angles
- Improved measuring accuracy with high resolution linear encoder
- Suitable stroke (450 x 400 x 200mm) for a variety of samples
- Streamlined software user interface enables every user to operate the system and create automated measurement programs

Accurate measurements of advanced products (i.e. smartphones and tablets) and high-speed image processing technology for mass production have become a standard inspection operation. This next-generation NEXIV system aims at fast and accurate measurement of the dimensions and shapes of high density and multi-layered electronic components.

Highly accurate and fast measurements

A higher level of accurate measurements is achieved by Nikon's in-house developed linear encoder. In addition, improvements to the image transfer technology and changes to the illumination source have shortened overall measuring time.

Measurement flexibility

A third ring illumination angle features advanced edge detection, while enhancements to the TTL (Through The Lens) Laser Auto Focus have strengthened the system's ability to measure transparent components.

Advanced operability

Work efficiency has improved by reducing the number of steps needed to create teaching files. Developed for easier understanding and better comprehension, the newly added "Guide Panel" function has improved the main program.

New 8-sector Ring Light system with three incident angles

Episcopic, diasopic and Ring illumination employ white LED and provide stability and long life.

New Ring Light System with three incident angles designed for correct edge capture.

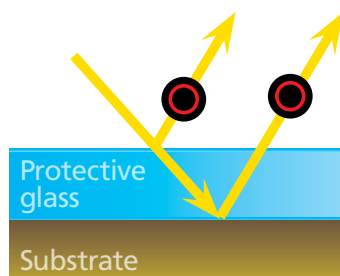

New Laser Auto Focus designed to detect surface of thin transparent material. The new sensor detect both top and back surface.



Low incident angle / Long WD

High incident angle / short WD

New 8-sector Ring Light system with three incident angles

NEXIV VMR series

Legendary optics combine with ultra-precise automated video measurement



Nikon offers a complete line of NEXIV vision systems, each possessing Nikon's trademark optical quality and rugged design for the highest precision measuring tasks. The NEXIV automated video inspection systems range from small to ultra-wide measurement platforms, and offer a variety of optical head options.



Outer ring illuminator extends application reach

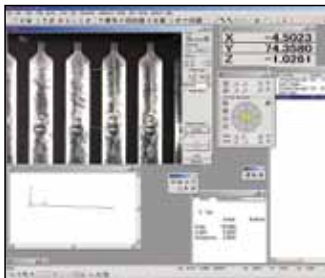

Metallized patterns of FPC

Applications

- Mechanical parts (e.g. machined, casted, stamped, etched and molded parts)
- Electronics (e.g. MEMS, probe cards, SMD, PCB, connector)
- Semiconductor packaging and advanced packaging technology (e.g. wafer-level CSP, flipchip)
- LCD-array process and flat panel display devices
- High-precision dies and molds
- Medical devices

Related solutions

NEXIV VMR systems are available in different stage sizes:

- NEXIV VMR-1515 (150x150mm)
- NEXIV VMR-3020 (300x200mm)
- NEXIV VMR-6555 (650x550mm)
- NEXIV VMR-10080 (1000x800mm)
- NEXIV VMR-12072 (1200x720mm)

Features

- Model types providing submicron accuracy
- Submicron accuracy achieved by robust hardware design and maximum magnification module VMR-Z120X, featuring 8-step zoom up to 120X
- Sophisticated VMR AutoMeasure software
- High-speed and highly accurate laser autofocus
- Optional 3D surface analysis, gear evolution, real-time SPC and rotary index

Benefits

- Broad size range of stages available (up to 1200x720mm)
- Advanced intelligent search enhances accuracy for increased productivity
- Excellent edge detection through advanced video edge probes and Nikon's proprietary edge detection algorithm (patent pending)
- Fast stage controls increase inspection yield



Larger NEXIV VMR systems offer stages with strokes up to 1200x720mm. They are ideally suited for measuring PCB patterns, display panels and large-size workpieces, such as FPD devices.

iNEXIV VMA-2520

Multi-sensor CNC video measuring system



The iNEXIV VMA-2520 is a lightweight and compact multi-sensor benchtop measuring system for fast, full-automatic and high-accuracy features. It is ideally suited for a wide variety of industrial measuring, inspection and quality control applications. The iNEXIV is designed to measure 3D workpieces, is touch probe ready, integrates the latest imaging processing software, and incorporates a new 10x optical zoom system and laser auto focus option.

The standard 10x zoom optics meet the industry's demanding needs for superb resolution at high magnifications while offering a wide field of view at low magnifications. Low distortion optics and high-intensity white LED illumination sources improve contrast to enhance throughput. This combination assures reproducible measurements even for colorful parts.

Applications

- Mechanical parts (e.g. metal and injection molding parts)
- Electronic devices
- Dies
- Molds
- Medical devices

Related solutions

- NEXIV video measuring systems
- VMA Automeasure software



Multi-sensor capability makes surface and side coordinate measurement of complicated 3D parts possible

Features

- Space-saving body weighing only 72kg
- 250 x 200mm xy stroke and 200mm z stroke
- Sophisticated VMA AutoMeasure software
- High-speed and highly accurate laser autofocus (option)
- Multi-sensor ready : vision, laser and touch probe

Benefits

- High accuracy through white LED illumination and use of aluminum alloy materials in the construction of the system
- Fast stage controls increase inspection yield
- New zooming optics make 3D part measurement easier
- Advanced image processing algorithm and intelligent search capability



iNEXIV VMA-2520



Vision autofocus



Aluminum die casting part

CONFOCAL Nexiv VMZ-K3040

3D FOV Measurements generated Using Confocal Images



Applications

- Bumps on advanced IC packages
- Probe cards
- Precise optical components (Micro lens, Contact lens)
- Laser marks on semiconductor wafers
- MEMS
- Wire bonding



Confocal images captured by Z scan are reconstructed in real time into 3D contour map and EDF (Extended Depth of Focus) images.

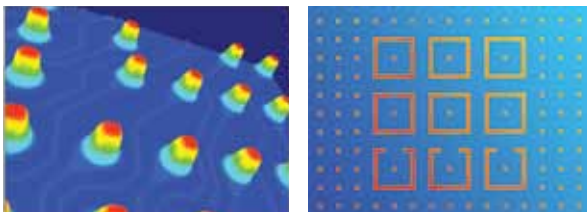

Bird's-eye view Wafer Level package with 3D viewer software (option)

Fine bump and substrate pattern

The Confocal NEXIV, a ground-breaking multi-functional video measuring system, was developed on the strength of Nikon's leading opto-mechatronics technologies. It incorporates confocal optics for fast and accurate evaluation of fine three-dimensional geometries, and brightfield optics with a 15x zoom. It allows both 2D and height measurements in the same field of view. The Confocal NEXIV can be optimally used for the inspection of highly complex structures such as bump heights on advanced semiconductor packages, probe cards and laser marks on wafers, etc.

Moreover, online communication software and an automatic 300mm wafer loading system for use in cleanrooms at semiconductor manufacturing fabs are also available to realize the fully automated confocal-based metrology system.

Features

- Simultaneous wide-area height measurements with Nikon proprietary confocal optics
- 2D measurement with 15x brightfield zoom optics
- Fully compatible with 300mm wafer measurement at semiconductor fabs

Wide range of magnifications

Four models are available: With 3x, 7.5x (below left), 15x, and 30x (below right) high NA and long working distance objective lenses. These options allow for optimum magnification and measurement of a variety of applications.

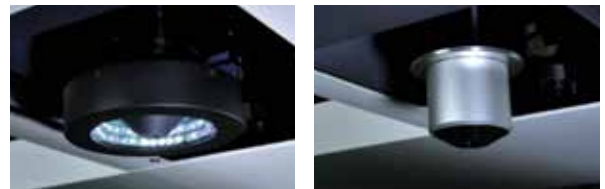

The dedicated 300mm wafer loading system for Confocal NEXIV allows fully automatic measurement by mounting wafer carriers on load ports. It corresponds with the measurement in-line process at semiconductor fabs.

MM-800/400/200 series of measuring microscopes

Measuring microscopes integrating digital imaging with industrial metrology



MM-800 measuring microscope

Nikon's measuring microscopes offer performance, convenience and an unprecedented degree of flexibility for upgrading and expansion. The MM400/800 Series deliver complete digital control for maximum measuring accuracy in demanding industrial environments. Measuring microscopes are excellently suited to inspect and measure 2D and 3D small parts.

The MM-200 is a compact and lightweight measuring microscope with an affordable price for all who require precision and accuracy for measuring a variety of metal, plastic and electronic parts in all industries; especially automotive and electronics.



CCD



Plastic gear teeth

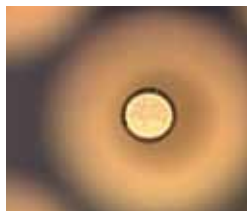

PGA – Insertion pin

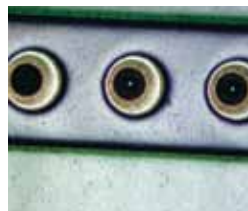

Brightfield image

Features

- Seamless integration with Nikon digital cameras and E-Max metrology software
- High-intensity white LED illuminator is standard for brightfield use
- Backpack interface facilitates automated illumination, XY stage and Z data control through an external computer running E-Max software
- Optional TTL Laser Auto-Focus
- For larger workpiece measuring, a stage up to 12x8 inch is available

Applications

- Lab-on-a-chip
- MEMS
- Plastic manufacturing (e.g. injection molded parts)
- Medical devices
- Microelectronics and optoelectronics
- Micro tooling
- Surface analysis
- Cracks & failure analysis

Benefits

- Excellent geometric data processing and storage
- Ease of operation greatly improved through various motorized controls and ergonomic design
- Added body strength allows for using larger stages
- Expanded observation range by offering many options in illuminators and light sources
- A fully motorized high-power microscopy model is also available for digital imaging capability

Related solutions

- NEXIV and iNEXIV video measuring systems
- Industrial microscopes



MM-200



MM-400

Profile projectors

Optical comparators with an effective screen diameter up to 600mm diameter



V-20B



V-12B

Nikon's profile projectors apply the principles of optics to the inspection of manufactured parts, by projecting the magnified silhouette of a part on a screen. To suit your specific application, each profile projector comes with multiple projection lenses, each featuring a different magnification, working distance and field of view size.

The V-24B top model has a large effective screen diameter of 600mm. Its superior magnification accuracy is ideal for measuring and inspecting profiles, surface conditions and other aspects of large workpieces.

The Horizon line of horizontal benchtop comparators yield powerful, reliable illumination for surface and profile inspection and measurement.

Related solutions

Different profile projector types are available:

- V-24B (Screen diameter 600mm, except for EC)
- V-20B (Screen diameter 500mm)
- V-12B (Screen diameter 300mm)
- Horizon 16E (Screen diameter 400mm, only for USA)

Applications

- Profiles (metal and plastic manufacturing)
- Surface conditions
- Other part aspects
- Crack and failure analysis

MF-1001/MF-501 Digimicro

Advanced photoelectric digital length measuring systems



M-1001 digital height gauge



M-501 digital height gauge

The MF-1001 and MF-501 Digimicro series offer flawless contact measurements of dimensions, thickness and depth. They feature measuring length equal to 100mm and 50mm respectively and accuracy of 1 μ m at 20°C. Stands are available in ceramic, steel or granite for added stability and a wide variety of probe tips are available to suit most applications

6B/6D Autocollimators

Brightfield and darkfield instruments for checking alignment and measuring angles



Nikon Metrology's autocollimators check alignment and measure very small angular deviations to measure flatness or height by simple geometry. Darkfield model autocollimator is perfect for measuring small, flat mirrors. Brightfield model autocollimator utilizes hallmark Nikon optics to illuminate surface details.

Applications involve surface flatness inspection, alignment of components with reflective surfaces (e.g. CD player pickup lens) as well as measurements related to machine tools (e.g. straightness in movement of stages, angles of indexers).

INDUSTRIAL MICROSCOPES



As a world leader in imaging technology, Nikon manufactures complete optical and digital microscope systems with outstanding versatility, performance and productivity for any application.

INDUSTRIAL MICROSCOPES

STEREOSCOPIC MICROSCOPES

PORTABLE MICROSCOPE

SCANNING ELECTRON MICROSCOPES

SOFTWARE

Eclipse series of industrial microscopes

Industrial microscopes at the forefront of optical and technological innovation



Eclipse LV150N

Nikon Metrology offers a complete portfolio of industrial microscopes for a wide range of applications, from basic models to sophisticated systems for high-end inspection. The Eclipse range featuring optical and digital microscope systems offers outstanding versatility, performance and productivity to tackle practically any application.

Features

- Choice of observation methods: brightfield, darkfield, polarizing, Nomarski DIC, episcopic, diasopic, epifluorescence, etc.
- Upright or inverted microscopes
- Premium ergonomics for comfortable viewing through tilting eyepiece tube, easy accessible controls, electrostatic protection, vibration isolation, etc.
- CFI60-2 optics achieve new levels of brightness, contrast and operability

Eclipse L300N microscope series of for large-size flawless inspection of LCDs and wafers

Configured for 300mm wafer and mask inspection, the Eclipse L300N Series also satisfies the need for flat panel display backend inspection. The L300N Series utilizes Nikon proprietary CFI60-2 optical system, offering high resolution, contrast and transmittance.

Eclipse L200N series of microscopes for inspecting 200mm wafers and masks

Combined with Nikon's superior CFI60-2 optical system and an extraordinary new illumination system, this microscope provides brighter images with greater contrast. The L200 series is ideally suited for the inspection of wafers, photo masks and other substrates.

Eclipse LV150N series of microscopes for industrial inspection

The Eclipse LV150 Series microscopes provide superb performance when inspecting semiconductors, flat panel displays, packages, electronics substrates, materials, medical devices, and a variety of other samples.

Small-footprint Eclipse LV100N series delivers superb optics and ergonomics

Nikon's Eclipse microscopes are renowned for their ability to produce clearer images with higher contrast. The LV100N delivers brighter images, lower power consumption and less heat generation, thereby reducing the chance of heat-induced focus drift.

Eclipse MA200 / MA100

MA200 is an inverted metallurgical microscope optimized for digital imaging and ergonomic efficiency. Its unique box design allows easy access to the sample on the stage and nosepiece, with a footprint, one third of the conventional model. The Eclipse MA100/MA100L is a compact-site inverted microscope developed for brightfield observation and simple polarizing observation.

Related solutions

- Modular design concept and huge choice of accessories (e.g. illuminators, objective lenses, stages, wafer loaders) to meet the inspection requirements
- Availability of microscope variants for dedicated inspection purposes (e.g. polarizing capability, metallurgical use)
- Availability of motorized nosepieces and digital imaging



Eclipse L300N



Eclipse LV100ND



Eclipse MA200



AZ100 Multizoom



CFI60-2 objectives offer the longest working distance and optimum chromatic aberration correction in a body that is lighter than ever.

SMZ 25&18 High-End Stereoscopic Microscope

A Giant Step Forward for Stereo Microscopy



The SMZ 25 and 18 are revolutionizing stereomicroscopy with their unique zoom range, along with modularity, comfort and ultra-high-performance optics. These new SMZ cover a wide range of functionality, from basic stereoscopic images of unparalleled quality to the most sophisticated observation

An innovative optical system known as "Perfect Zoom Optics" provides the world's first zoom ratio of 25:1. Even with a 1x objective lens, the SMZ25 captures the entire 35mm dish and simultaneously delivers microscopic details.

Features

- World's largest zoom range (25:1 for SMZ25) and highest resolution in the SMZ series
- Motorized focus and zoom operation (SMZ25)
- Crystal clear images in fluorescence as well as normal illumination techniques
- Easy-to-operate slim LED DIA base with OCC illumination (oblique lighting method developed by Nikon)



Injection needle



Printed circuit board (brightfield)



Printed circuit board (fluorescence)



Watch

Complete range of Stereoscopic Microscopes

Complete line-up delivers optimal observation performance



SMZ1500 was designed with scientists in mind enabling to see and photograph any specimen, from macro views to high-magnification micro visualization.



SMZ800/1000

Nikon zoom stereomicroscopes offer users the most extended zoom range along with modularity, comfort and ultra-high-performance optics. An extensive set of options such as motorized nosepieces, digital imaging, different stages, etc. enable the user to configure his Nikon stereomicroscope to his needs.

Related models

- SMZ 445-460
- SMZ 660
- SMZ 745-745T
- SMZ 800 - SMZ1000 - SMZ1500

BW-S50X White Light Interferometric Microscope System

Ultra High Vertical Resolution of 1 Pico-Meter Microscopic Observation and Image Capturing



BW-S50X series measure surface profiles from sub-nano to millimeter height ranges speedily and accurately. BW series are available with optical microscope such as LV150N, MM800, L300N, CM10, etc.

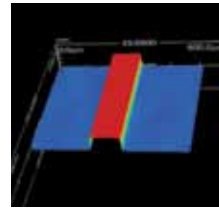

VLSI Step Height Standard: 8nm

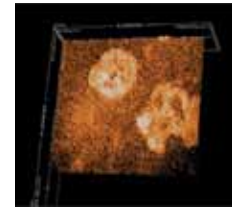

The Planarized SiC Wafer

Configurations

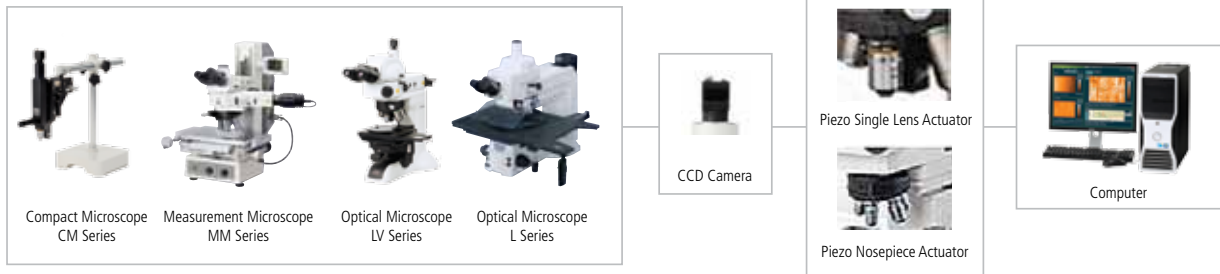

NeoScope benchtop SEM

Combining digital camera familiarity with scanning electron microscope (SEM) capability



NeoScope SEM

The JCM-6000 "NeoScope™", is a touch panel controlled, multi functional desktop scanning microscope that answers the increasingly diversified needs among users worldwide. Offering the high resolution and depth of field of a powerful SEM, NeoScope helps accelerate the pace of failure analysis of manufacturing materials.

Basic operation of the NeoScope is simple with auto focus, auto contrast and auto brightness controls. Samples can be loaded and imaged in less than three minutes, without requiring any special sample preparation. Pre-stored parameter files (recipes) allow the user to quickly and automatically set up the NeoScope for a wide variety of material samples. The NeoScope operates in both low and high vacuum modes and has three settings for accelerating voltage.



Diatoms

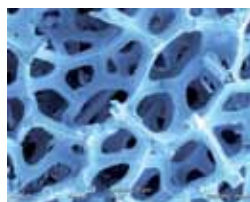

Foam

ShuttlePix P-400R digital microscope

A handheld microscope offering portability and ease-of-use of a digital camera



ShuttlePix 400R is a revolution in microscopy. A handheld digital microscope enabling you to take images everywhere, even on places where you never could imagine using a microscope. ShuttlePix features Nikon optics to guarantee razor sharp images and feels as comfortable as a digital camera. Featuring 20x optical zoom with up to 400x magnification and a 4-segment LED ring light, it allows to capture highly detailed images in any light conditions.

And what's more, one can even use the ShuttlePix as a digital desktop microscope. This portable microscope targets a wide range of industrial applications that require fine image recording and inspection without having to move the sample.



Point-and-shoot image indoors or outdoors, regardless of the lighting conditions

Applications

- Industrial parts and materials
- Pipe lines and structures
- Car, boat and airplane engines and frames
- Electronics
- Molded parts
- Artwork restoration and conservation
- Forensic investigation

Related products

- Motorized Z-axis stand
- Sample stages (sliding, tilting, etc)
- Touch panel monitor



Desktop use with motorized Z-axis stand and touch panel microscope control

Features

- 20-400x zoom range spanning from low to high magnifications (20x optical zoom)
- Integrated 4-segment ring LED illumination
- Desktop use with motorized Z-axis stand and touch panel microscope control.
- Extended depth of focus (EDF) on the motorized focusing stand controller
- TIFF and JPEG image storage through USB or SD card
- Complete set of accessories

Benefits

- Point-and-shoot image indoors or outdoors, regardless of the lighting conditions
- Ergonomic, handheld microscope with Nikon optical quality
- Multi-purpose use in the field and in the lab
- No microscope knowledge or experience required to operate ShuttlePix
- Dedicated applications software supports graphic analysis and reporting



Cast metal



Crack in wall

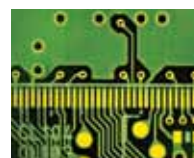

Electronics



Painting

NIS-Elements software

Comprehensive device control and image analysis, visualization and archiving tools

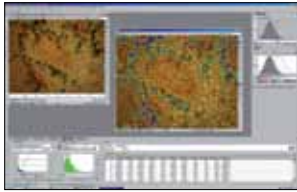

NIS-Elements revolutionizes imaging software for the microscopy market by combining automated intelligence to microscopes, cameras, components and peripherals with powerful archiving, analysis, visualization and archiving tools. Its intuitive interface simplifies workflow and speeds up image acquisition times while providing a versatile range of features, such as image stitching, object counting and volume views.

AutoMeasure (Measuring instruments)

User-friendly software that makes measuring automation simple



AutoMeasure integrates an intuitive wizard menu, customizable GUI and engineer/operator mode within a multiple-language environment. AutoMeasure software runs on iNEXIV VMA and NEXIV VMR video measuring systems.

E-Max Series of data processing Software (Measuring instruments)

FOV measurement with advanced digital imaging processing technology



The E-MAX series software offers state-of-the-art image processing that supports general-purpose measurement for a wide range of manual measuring instruments, including measuring microscopes and profile projectors.

METROLOGY ASSISTED PRODUCTION / ROBOTICS

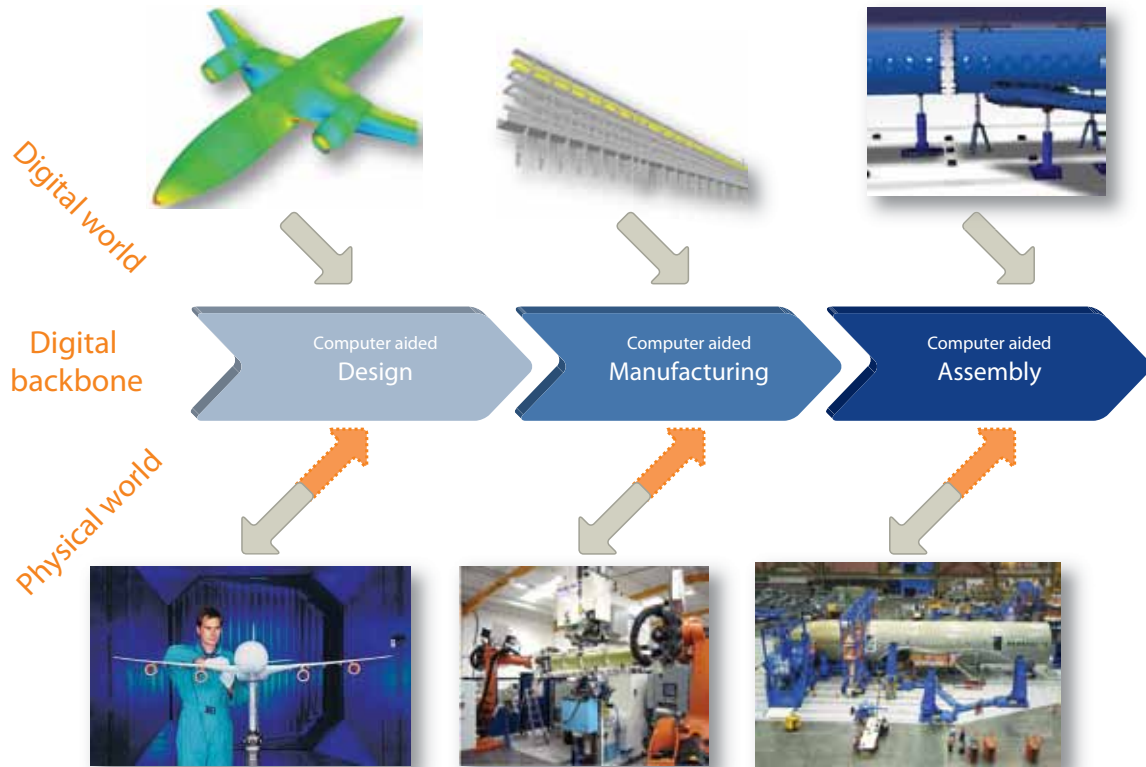

Nikon Metrology assists customers in successfully deploying metrology-driven manufacturing capability. Metrology assisted production builds on accurate geometric data to consistently increase the precision and speed of design, manufacturing and assembly operations.

LASER RADAR

iGPS/iSPACE

ADAPTIVE ROBOT CONTROL

K-ROBOT

Laser Radar MV330/350

Automated, non-contact large volume inspection



Laser Radar is a versatile metrology system that offers non-contact and true single-operator inspection. As it is CNC-programmable, it is ready for completely automated unattended operation. Laser Radar incorporates patented laser reflection technology that allows for direct surface and feature measurement at high data rates. As a result, Laser Radar eliminates the tedious use of photogrammetry dots, spherically mounted retroreflectors (SMRs) or handheld probes, slashing inspection time and operator overhead. Laser Radar is able to scan dark diffuse and highly reflective material and finish surfaces at challenging incident angles.

Applications

- Inspection of fuselage, wing, wing/body connection, landing gear door and jet engine blade
- Gap and step inspection of jet engine cowling
- Automated inspection of riveting hole positions
- Mold, first article and serial inspection of composite parts
- On-machine verification of large machined parts
- Dimensional verification of forged and molded parts before milling process starts
- Measuring wind turbine blades and concentrated solar panels
- Verification of space telescope hardware, parabolic antenna and heated surface

Related solutions

- iGPS and iSpace

Features

- Measurement range for MV350 up to 50m, MV330 up to 30m
- Vision Scan inspection mode captures up to 2000 points per second
- Accuracy from 24µm (2m distance) to 201µm (20m distance)
- Powerful hole and edge measurement capabilities
- Expanded line of sight using mirrors
- All acquired data referenced to a single contiguous coordinate system
- Supports a variety of large volume metrology software

Benefits

- Productivity multiplier thanks to fast measurement and low operator overhead
- Non-contact measurement ideal for delicate and inaccessible specimens
- Automation saves on operator expenses and manipulation errors
- Reliable range measurements on composite materials
- Seamless integration in measurement process

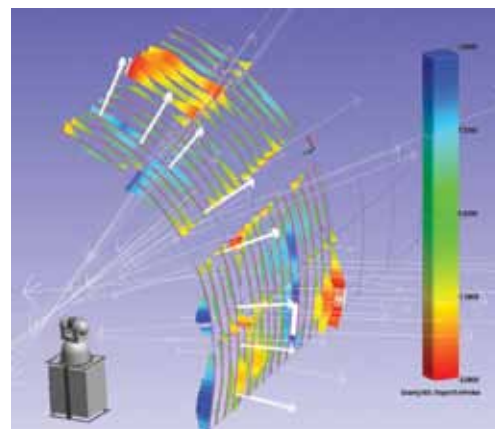

Laser Radar's use in green energy markets is increasing because it is capable of measuring large and delicate structures such as solar panels and wind turbine blades

Modular positioning, tracking and measurement system for factory-wide deployment



iGPS is a modular large scale metrology solution that transforms large fabrication facilities into accurate metrology-enabled areas. Within the facility, an unlimited number of handheld measurement probes or tracking sensors (fixated on tools and components) can operate concurrently.

Unique iGPS capabilities in terms of scalability, robustness and concurrent use provide quick return on investment as well as a solution that grows along with expanding manufacturing operations.

Predefined iSpace configuration packages use iGPS technology to track multiple measuring devices – handheld probes, articulated arms and laser radars – that can be operated concurrently.

Applications

- Large scale positioning and tracking suited for aerospace, shipbuilding, train, etc.
- Part joining and assembly
- Dynamic tracking of parts, tools, robot positions, AGVs and ship models in water tanks
- Handheld large volume inspection in automotive (engineering lab, racing workshop), aerospace and other industries like casting and turbine blade production
- Automatic annotation of handheld NDT measurements with positional information

Related solutions

- iProbe - 6DOF tactile measurement probe
- iMCA - iSpace enabled articulated arm
- Integration Services & Technologies



i5 integrated sensor

Features

- Expand measurement volume by extending transmitter network (iGPS)
- Measurement volumes ranging from 400 to 1200m³ (iSpace)
- Continuous health monitoring and transmitter redundancy
- Unlimited number of users and applications within the iGPS-enabled working volume
- Multiple devices can be equipped with iGPS receivers for accurate positioning

Benefits

- Supports factory-wide deployment (iGPS)
- Easily deployable for measuring the dynamic positioning of handheld probes, articulated arms, laser radars and other measurement equipment (iSpace)
- Uniform accuracy throughout the entire workspace
- Scalable, accurate and robust solution
- Concurrent use of an unlimited number of handheld probes and tracking sensors
- Point localization accuracy down to 200µm

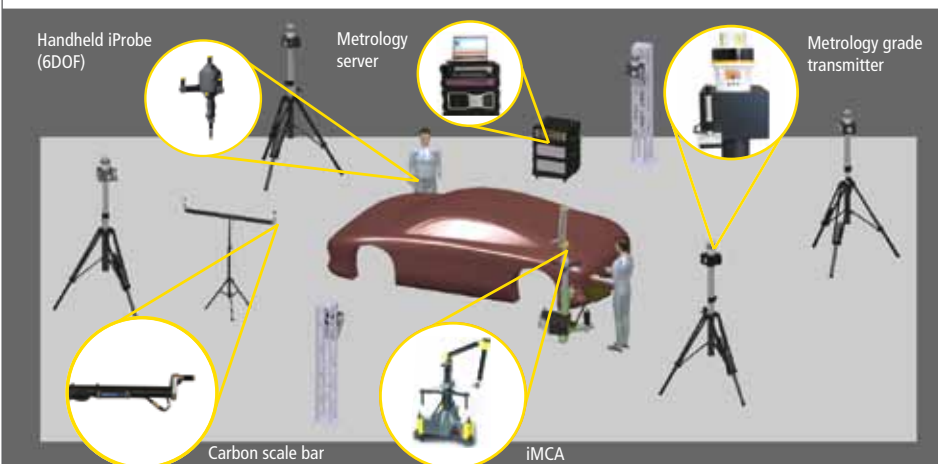

iSpace supports concurrent use of an unlimited number of handheld probes and tracking sensors



Using iProbe the operator can freely walk around and perform measurements in a large volume

Adaptive Robot Control

Accurate robot positioning in any circumstances



Applications

- Accurate drilling and riveting on wings and fuselages where the motion of the part is monitored
- Robot machining (drilling/fettling/milling) where the motion of the tool is monitored
- High-precision placement of objects or tools
- Accurate material depositing (sealant, tape layering, etc.)

Related solutions

- K-Series Optical CMM
- Robot calibration & testing
- Integrated Services & Technologies

Adaptive Robot Control activates a closed metrology-driven feedback loop that firmly increases the precision of industrial robots. Regardless whether robots are deployed for machining, inspection, applying beads or manipulating objects, roboting tasks are consequently executed with 0.1mm absolute accuracy, irrespective of degrading phenomena like play, mechanical flexibility, backlash or thermal effects.

Features

- Dynamic tracking and closed feedback loop to robot controller
- Tracking volume of 17m³ (expandable)
- Tracking sample rate up to 1000Hz
- Simultaneous measurement of up to 1024 points
- Accuracy down to 0.1mm in the entire working volume of the robot

Benefits

- Independent metrology chain for industrial robot applications
- Providing high level of absolute robot accuracy
- Portable and scalable solution
- Investment is only a fraction of new product equipment with comparable accuracy



Adaptive Robot Control - driven by Optical CMM or iGPS - establishes a closed feedback loop that nearly eliminates the influence of robot warm-up, drift and backlash

In-line robotized scanning and inspection



K-Robot is a flexible, productive and accurate metrology solution for in-production-line inspection using an industrial robot. The Optical CMM dynamically tracks the location of K-Robot's ModelMaker laser scanner while the robot is running an automatic scanning job. High scanning accuracy is guaranteed, as proven metrology components of K-Robot obsolete cyclic robot calibration and eliminate the influence of robot warm-up, drift and backlash.

Features

- Global absolute accuracy: better than 100µm in the entire work volume
- Robust against ambient light conditions
- Inspection results in Microsoft Excel and SPC-compatible formats
- Automatic rapid digitizing for part-to-CAD inspection or adaptive machining
- Excellent material scanning and fast data acquisition
- Operating temperature range from +15 to +35°C (59 - 95°F)

Applications

- Feature and surface inspection
- Gap & flush
- Sheet metal and body-in-white as well as forged or molded parts
- Partial in-line inspection of the entire production volume
- Complete bypass inspection of production samples

Benefits

- Truly absolute measurement accuracy
- Eliminates effects of robot warm-up, drift and backlash
- Interfaces to any robot brand, size and accuracy level
- High scanning accuracy and throughput
- Off-line teaching and programming

Related solutions

- ModelMaker laser scanners
- K-Series Optical CMM
- Adaptive Robot Control

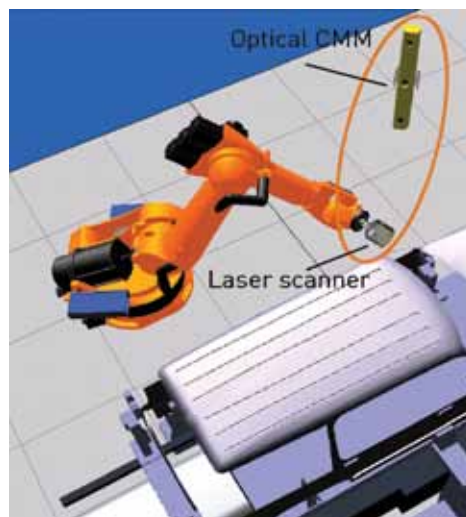

K-Robot's independent metrology chain and closed feedback loop guarantee high scanning accuracy



Fast repetitive laser scanning for in-production-line inspection

Nikon Metrology services and support

A vision of Total Customer Support

Nikon Metrology provides ISO9001/2000 and UKAS accredited metrology solutions to a wide range of industries and bluechip customers in a global marketplace, utilizing a worldwide network of highly trained metrology experts. The complete range of services including helpdesk support, training, maintenance programs, retrofit capabilities and contract work, enables our customers to get the maximum value out of their Nikon Metrology solutions or to solve their inspection issues in the shortest possible time.

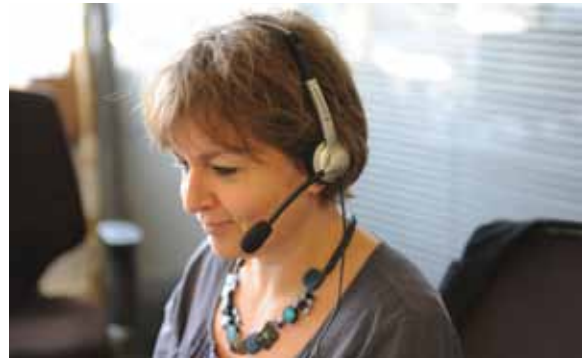

HELPDESK

Instant help – the skills and technical knowledge to solve your application/software problems by dedicated helpdesk engineers.

METROLOGY TRAINING/SEMINARS

Knowledge base – on-site/off-site, basic, intermediate and advanced software and hardware training and seminars using dedicated staff with hands-on experience.

PROGRAMMING CONSULTATION

Operational assistance - highly-skilled engineers provide part programs or programming consultation - expertise which can reduce your product inspection costs.

MAINTENANCE AND CALIBRATION

Technical service – the manpower, state-of-the-art technology and logistics to maximize reliability, uptime and equipment performance.

SUB-CONTRACT INSPECTION

Nikon Metrology offers a wide range of subcontract inspection work. The broad product portfolio includes the right tool for every inspection challenge of the customer. On top of Nikon Metrology own inspection service facilities, Nikon Metrology also has a broad worldwide network of Nikon Metrology Service Centers, that are accredited by Nikon Metrology to perform contract inspection work.

- UKAS accredited CMM sub-micron, temperature-controlled inspection offering the capability to measure all component types and sizes.
- Laser scanning work for part-to-CAD inspection or Reverse Engineering
- X-ray and CT inspection work for electronics and industrial applications

UPGRADES AND RETROFITS

Existing CMMs often see an improvement in performance, life expectancy, and accuracy with the retrofit of an advanced Nikon Metrology CMM controller, powerful DMIS-compliant Camio Studio or CMM-Manager software or an innovative Nikon Metrology scanner. A full range of hardware upgrades and retrofits is available to meet all of your current and future needs.



SOFTWARE UPGRADES

The rapid development of CMM metrology software means that CMMs may face operational issues with outdated software, regardless whether supplied by Nikon Metrology or as part of your existing CMM system. Nikon Metrology retrofits your CMM with the latest, easy-to-use Camio or CMM-Manager 3D metrology software, either through Nikon Metrology-Controller technology, proprietary protocol support or via the I++ DME open protocol standard. Whether you use manual or CNC CMMs, Nikon Metrology has an extensive range of software products designed to support your programming and reporting applications.



Multi-Sensor Coordinate Measuring Machines

X-Ray and CT Insight

Measuring Instruments

Industrial Microscopes

Metrology Assisted Production

Services and Support

**NIKON METROLOGY NV**

Geldenaaksebaan 329
B-3001 Leuven, Belgium
phone: +32 16 74 01 00 fax: +32 16 74 01 03
Sales.NM@nikon.com

NIKON METROLOGY EUROPE NV

tel. +32 16 74 01 01
Sales.Europe.NM@nikon.com

NIKON METROLOGY GMBH

tel. +49 6023 91733-0
Sales.Germany.NM@nikon.com

NIKON METROLOGY SARL

tel. +33 1 60 86 09 76
Sales.France.NM@nikon.com

NIKON METROLOGY, INC.

tel. +1 810 2204360
Sales.US.NM@nikon.com

NIKON METROLOGY UK LTD.

tel. +44 1332 811349
Sales.UK.NM@nikon.com

NIKON CORPORATION

Shin-Yurakucho Bldg., 12-1, Yurakucho 1-chome
Chiyoda-ku, Tokyo 100-8331 Japan
phone: +81-3-3216-2384 fax: +81-3-3216-2388
www.nikon-instruments.jp/eng/

NIKON INSTRUMENTS (SHANGHAI) CO. LTD.

tel. +86 21 5836 0050
tel. +86 10 5869 2255 (Beijing office)
tel. +86 20 3882 0550 (Guangzhou office)

NIKON SINGAPORE PTE. LTD.

tel. +65 6559 3618

NIKON MALAYSIA SDN. BHD.

tel. +60 3 7809 3609

NIKON INSTRUMENTS KOREA CO. LTD.

tel. +82 2 2186 8400

More offices and resellers at www.nikonmetrology.com