

AFRL-IF-RS-TR-2006-149
Final Technical Report
May 2006



NON-LINEAR ACOUSTIC CONCEALED WEAPONS DETECTOR

Luna Innovations, Inc.

APPROVED FOR PUBLIC RELEASE; DISTRIBUTION UNLIMITED.

**AIR FORCE RESEARCH LABORATORY
INFORMATION DIRECTORATE
ROME RESEARCH SITE
ROME, NEW YORK**

STINFO FINAL REPORT

This report has been reviewed by the Air Force Research Laboratory, Information Directorate, Public Affairs Office (IFOIPA) and is releasable to the National Technical Information Service (NTIS). At NTIS it will be releasable to the general public, including foreign nations.

AFRL-IF-RS-TR-2006-149 has been reviewed and is approved for publication.

APPROVED: /s/

PETER COSTIANES
Project Engineer

FOR THE DIRECTOR: /s/

JOSEPH CAMERA
Chief, Information & Intelligence Exploitation Division
Information Directorate

REPORT DOCUMENTATION PAGEForm Approved
OMB No. 074-0188

Public reporting burden for this collection of information is estimated to average 1 hour per response, including the time for reviewing instructions, searching existing data sources, gathering and maintaining the data needed, and completing and reviewing this collection of information. Send comments regarding this burden estimate or any other aspect of this collection of information, including suggestions for reducing this burden to Washington Headquarters Services, Directorate for Information Operations and Reports, 1215 Jefferson Davis Highway, Suite 1204, Arlington, VA 22202-4302, and to the Office of Management and Budget, Paperwork Reduction Project (0704-0188), Washington, DC 20503

1. AGENCY USE ONLY (Leave blank)		2. REPORT DATE MAY 2006	3. REPORT TYPE AND DATES COVERED Final MAR 04 – NOV 05	
4. TITLE AND SUBTITLE NON-LINEAR ACOUSTIC CONCEALED WEAPONS DETECTOR			5. FUNDING NUMBERS C - FA8750-04-C-0043 PE - N/A PR - NIJR TA - BA WU - 01	
6. AUTHOR(S) Anjani Achanta				
7. PERFORMING ORGANIZATION NAME(S) AND ADDRESS(ES) Luna Innovations, Inc. 2851 Commerce Street Blacksburg Virginia 24060			8. PERFORMING ORGANIZATION REPORT NUMBER N/A	
9. SPONSORING / MONITORING AGENCY NAME(S) AND ADDRESS(ES) Air Force Research Laboratory/IFEC 525 Brooks Road Rome New York 13441-4505			10. SPONSORING / MONITORING AGENCY REPORT NUMBER AFRL-IF-RS-TR-2006-149	
11. SUPPLEMENTARY NOTES AFRL Project Engineer: Peter Costianes/IFEC/(315) 330-4030/ Peter.Costianes@rl.af.mil				
12a. DISTRIBUTION / AVAILABILITY STATEMENT APPROVED FOR PUBLIC RELEASE; DISTRIBUTION UNLIMITED.				12b. DISTRIBUTION CODE
13. ABSTRACT (Maximum 200 Words) The major findings of this effort clearly demonstrate that Non-linear Acoustics is a low cost alternative to conventional imaging methods for concealed weapons detection. Our approach is to use ultrasonics to create a localized zone where non-linear interactions generate a lower frequency acoustic wave that is steerable and is able to penetrate clothing better than direct ultrasonics. We have been able to detect guns of various sizes, box cutters, knives and distinguish weapons from non-weapons including plastic devices. Sophisticated software generated signals with customized transducer/receiver design have been able to provide characteristic information about a hidden weapon 15 feet away and classify the weapon based on a database approach. Most recently improved software allows user-friendly display of results with images. We are confident of the readiness of our work for prototype development. In addition to being able to detect the weapons mentioned above, we have also been highly successful in imaging improvised weapons (received from the DOJ/AFRL lab) from a near range distance.				
14. SUBJECT TERMS Concealed Weapons Detection, Non-linear Acoustics, Signatures; Resonance; Scattering; Acoustic Wand; Improvised Weapons			15. NUMBER OF PAGES 60	
			16. PRICE CODE	
17. SECURITY CLASSIFICATION OF REPORT UNCLASSIFIED	18. SECURITY CLASSIFICATION OF THIS PAGE UNCLASSIFIED	19. SECURITY CLASSIFICATION OF ABSTRACT UNCLASSIFIED	20. LIMITATION OF ABSTRACT UL	

Table of Contents

1. Project Summary.....	1
2. Work Status and Recommendations for Future Work.....	5
3. Detailed Description of Results	5
4. Introduction.....	5
5. Non-linear Acoustic Concept.....	6
6. Near Range Scanning.....	10
7. Long-Range Scanning.....	12
8. Long Range detection: LabView user interface.	36
9. Future Work:	39
10. Conclusions:	42
11. Bibliography	43
Appendix A: Additional Results.....	45
Appendix B: Simulations.....	50
Appendix C: Letter of Support	54

List of Figures

Figure 1: Long range detection of concealed weapons for street systems from 15 feet.	3
Figure 2: Handcrafted weapon vs. non-weapon detected from 15 feet.	4
Figure 3: Images of three weapon-like objects covered with two layers of fabric scanned from 6 inches distance.....	4
Figure 4: Experimental set-up for conducting non-linear acoustic parametric beam mixing.	7
Figure 5: Theoretical representation of sound pressure field for a non-linear vs. linear pulse propagating away from the transducer.	9
Figure 6: Near range image showing the contrast between weapon and non-weapon. The image area corresponds to a small portion of the sample target.....	10
Figure 7: Improvised weapons made by inmates.....	11
Figure 8: Non-linear acoustic scanning images of three weapons covered with two layers of fabric.	11
Figure 9. Simulated data showing the axial absorption plots for the audio (left) and ultrasound (right) components of the sound beam.....	13
Figure 10. Simulated data showing beam-width profiles for the audio (left) and ultrasound (right) components of the sound beam measured at various distances from the parametric transducer.	14
Figure 11. Simulated 8000 Hz component of the acoustic beams created from a 1 ft diameter flat transducer (top) and a 2 ft diameter focused transducer (bottom).....	15
Figure 12: Experimental set-up showing the beam characterization at 15 feet for a focused audio spotlight.	16
Figure 13: A plot of calibration data for ultrasonic sound pressure amplitudes with the xy origin at 15 ft.....	16
Figure 14: Experimentally measured focused Vs. unfocused output audio intensity measured at 17 feet.	17
Figure 15: A picture of the elliptical receiver dish mold under fabrication is shown here.....	18
Figure 16: A picture of the elliptical receiver dish with a sensitive microphone at its focus.....	18
Figure 17: NAC signal received from a specimen covered with clothing and no weapon underneath.....	19
Figure 18: Experimental set-up for concealed weapons detection using the parabolic receiver dish and the Hypersonic Sound transmitter.	20
Figure 19: NAC signal received from a plastic gun covered with clothing.....	20
Figure 20: A 32ms chirp signal created such that the source frequency chirp is starting from 0.1 kHz to 10 kHz, increasing linearly though the chirp.	21
Figure 21: Weapon simulants used for testing and developing analysis algorithms.....	21
Figure 22: Pictures of experimental set-up for detecting signatures through thick clothing	22
Figure 23: Acoustic signature of a tube showing various frequency bands separated by tube's natural frequency.....	23
Figure 24: Specular or flat-plate reflection indicated by the flat line of the linear input chirp incident on the target	24

Figure 25: Pictures of real guns that were used for testing. Also shown are areas of welding where these real guns have been disabled.....	25
Figure 26: Approval notice from a certified gunsmith showing that the guns are actually disabled.....	26
Figure 27: Pictures showing the experimental set-up and the use of the real guns as concealed weapons.....	27
Figure 28: Offline correlation coefficient result for a Big gun. The resulting value of the coefficient was significantly higher compared to other objects.....	31
Figure 29: Offline correlation coefficient for a Box cutter (actual weapon). The resulting coefficient was significantly higher compared to other objects in the database.....	31
Figure 30: Comparison of classification results for weapons in two different positions..	32
Figure 31: Combination of time and frequency domain correlation for improving analysis results.	33
Figure 32: Pictures of two of the several different positions in which the weapon's signature was recorded for the database.	34
Figure 33: Input chirp signal, with a varying frequency structure over 32 ms time, designed to resonate a wide range of objects.....	34
Figure 34: A medium size gun (blue has highest correlation coefficient) that was classified correctly with the improved analysis technique	35
Figure 35: Experimental set-up for CWD tests on people, with improved software.....	36
Figure 36: Data analysis result with an image display for a case tested with "a person with no weapon on him"	37
Figure 37: Data analysis result with an image display of weapon for a case tested with "a person hiding a gun as a weapon".....	37
Figure 38: Data analysis result with a image display of weapon for a case tested with "a person hiding a box cutter as a weapon".....	38
Figure 39: Schematic diagram for the phased array system proposed for future work. This is based on an ongoing project funded by DARPA	40
Figure 40: Output connection for high voltage drive on transducers for the proposed phase array system	41
Figure 41: Internal block diagram for IR21844 showing level shifter and the two floating outputs to drive both output devices.....	41

List of Tables

Table 1: Weapon classification result summary for three unknown objects	23
---	----

1. Project Summary

Non-linear acoustics (NAC) has been shown to be a viable technique for concealed weapons detection. In this 18 month effort, Luna Innovations in partnership with the College of William and Mary has completed a thorough investigation of this novel acoustic approach. Beginning with small scale laboratory proof of concept tests to 15 foot stand off tests on people, we have successfully demonstrated the NAC approach for detecting concealed weapons such as guns, knives, box cutters and weapons that are of interest to NIJ.

The first phase of this project was focused on proving the non-linear beam mixing concept, developing preliminary software, mathematical models and simulating laboratory results for designing long range hardware. The following Phase I+ of this project was dedicated towards building a fixed focus-high power ultrasonic sources and a custom fabricated receiver hardware to extend our results to 15 feet as required by the technical monitor of this project.

The major findings of this effort clearly demonstrate that NAC is a low cost alternative to conventional imaging methods, using the principle of non-linear acoustic beam mixing. The concept is based on using two high frequency ultrasonic beams to inspect a small region on a person and assessing the acoustic impedance, resonance features and material interactions at the target. Our approach uses ultrasonics to create a localized probing zone through nonlinear interactions occurring in air, which in turn cause the generation of a lower frequency acoustic wave. This acoustic wave is steerable and is able to penetrate clothing better than direct ultrasonics.

We have been able to detect guns of various sizes, box cutters and knives and distinguish weapons from non-weapons including plastic devices. Sophisticated software generated signals with customized transducer/receiver design have provided characteristic information about hidden weapons 15 feet away. Our algorithms are trained to classify a weapon based on a database approach. Most recently improved software presents user-friendly displays of results enabling the use of our system with minimum technical skills. We are confident of the readiness of our work for a prototype development.

In addition to detecting the weapons mentioned above, we have also been highly successful in imaging improvised handcrafted weapons from a near range distance. Many of the imaging results have been shared with NIJ and our success generated high interest at the corrections facilities as well. (Letter of support in Appendix C). In the sections that follow, we describe the various stages of our effort to clearly illustrate our results from proof of concept to full-scale weapons detection tests at 15 feet. Recommendations that follow at the end of this section outline a quick path to build a prototype instrument.

The major Phase I accomplishments are as follows:

- *Non-linear acoustic beam mixing produced sound at localized interrogation spot that is not possible with conventional ultrasound.*
- *Using parametric beam mixing technique, we have demonstrated to NIJ that we can detect **real weapons hidden on people** in multiple scenarios from a fixed distance of 15 feet. The type of weapons include:*
 - *Guns of various sizes; Box cutters; Pocket knives; Scissors; Plastic weapons*
- *Our method has been tested on different people, **different clothing types**, and many **simulated and real weapons** at different orientations.*
- *We have developed a signal processing tool that is based on a database of **acoustic signatures** and the analysis results could differentiate between weapons and non weapons.*
- ***Mathematical models** have been developed and were found useful for designing hardware needed for full scale CWD tests. Simulations developed in MATLAB allowed testing various transducer configurations and visualization of sound fields.*
- *We have **extended simulation results** for visualizing beam widths and sound pressure levels beyond 15 feet up to 15 meters.*
- *We have designed and **fabricated customized ultrasonic hardware** for producing high intensity acoustic sound pressure levels through non-linear approach that are ideal for standoff CWD.*
- ***Software** has been developed for generating complex excitation signals that are computer controlled and tailored to acoustically detect weapon features from a 15-foot **distance**.*
- ***CWD user interface** has been developed for simple pictorial interpretation of the results by the DOJ officers. A handheld implementation scheme is also proposed in this report.*
- *In addition to being able to detect weapons from 15 feet, we have been successful in **imaging improvised weapons** from near range distances for use in prison security. In addition to imaging, we have also been successful in detecting improvised weapons using the acoustic spectral signatures. Weapons that were provided by NIJ were scanned using NAC approach and clearly demonstrate that this approach can quickly result in the development of an “**Acoustic Wand**” for detection of concealed weapons and objects in corrections facilities.*

- We have been actively communicating with various industrial players that would benefit from this technology and in that process provide law enforcement community with a CWD tool of great value.
- As part of this outreach effort, a paper describing this program has recently been published in the December issue of *Materials Evaluation* in a special issue dedicated to Homeland Security.

Following is a preview of the exciting findings during this project.

1: Long range detection of weapons.

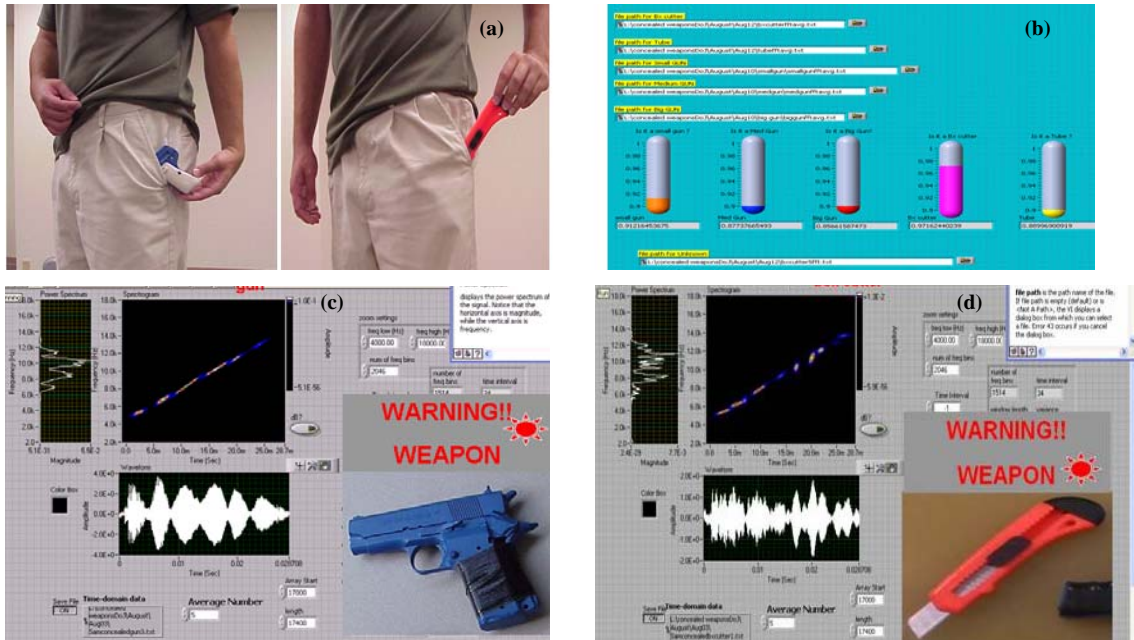

Figure 1: Long range detection of concealed weapons for street systems from 15 feet.

(a) NAC was tested for different weapons (variation in people, their clothing types and weapon orientation were also studied); (b) offline post processing that ensures a clean database; weapon orientation were also studied; (c) Real-time test result for a chirp signal test from a target person with no weapon; (d) Real-time test result for a chirp signal test from a target person with a concealed box cutter, set up shown in (a).

2: Weapon Vs Non-weapon signature from 15 feet

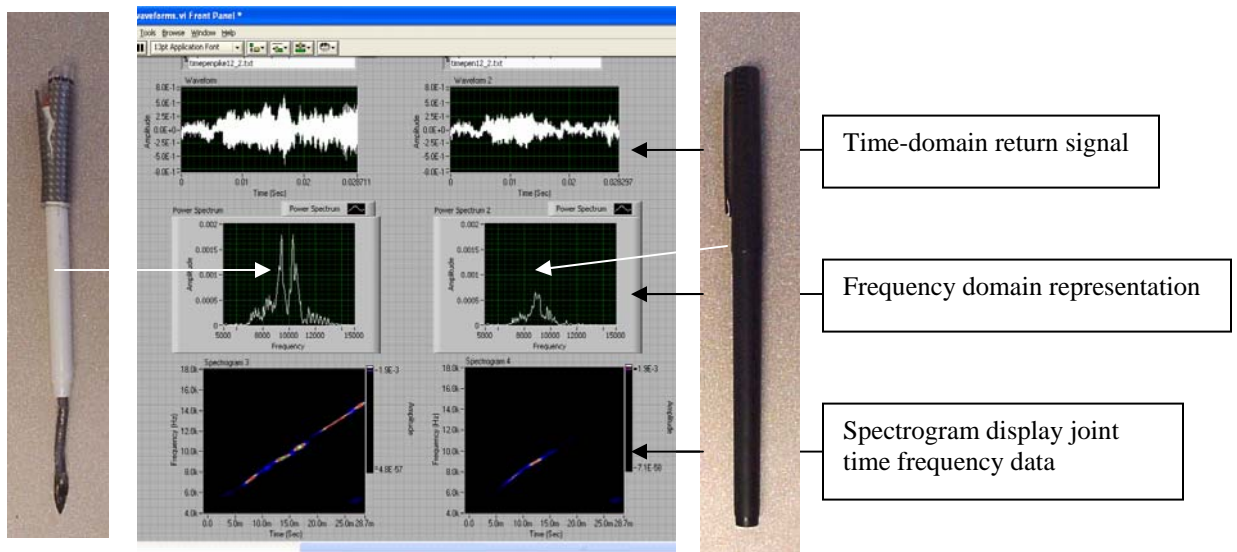
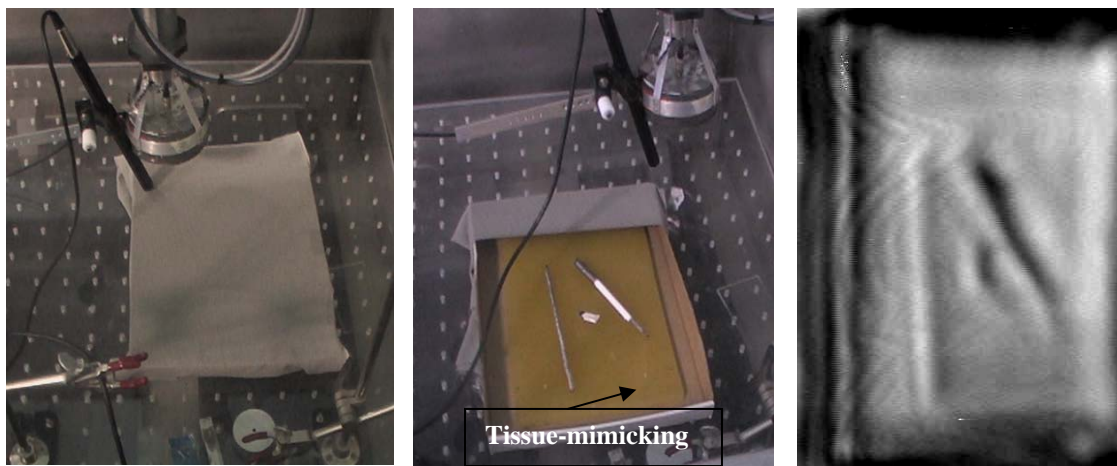

Figure 2: Handcrafted weapon vs. non-weapon detected from 15 feet.

Signatures recorded for a weapon (pen pike) and a non-weapon (a pilot pen) compared to each other. The signal from a weapon “stands out” indicating a suspicious object. The signal was recorded from 15 feet away with the objects hidden under clothing on a person.

Near range detection for prison systems (6 inches):



The specimen was placed on a tissue-simulating gel under two layers of stretched fabric using a 7.5 kHz probing beam. There is no visual information on the presence of the weapons underneath.

Figure 3: Images of three weapon-like objects covered with two layers of fabric scanned from 6 inches distance.

2. Work Status and Recommendations for Future Work

We have demonstrated successful results for CWD for a fixed focus. A significant outcome of this project has been the use of non-linear spectral acoustic signatures for weapons detection and identification. In addition to this, we also obtained successful imaging results from scanning improvised weapons that were completely concealed under clothing. Due to simplicity of hardware and fewer variables occurring in a prison environment, Luna proposes to explore the concept of an acoustic wand for prison security as an immediate next step. We have received an excellent response from various key personnel in the corrections community. The PI's discussion of results on near range CWD was well received by other industrial players for exploring possible partnerships.

For a realistic implementation for street use, a dynamic/variable focus hand-held system is desired by NIJ. Luna would like to explore the building of such a system for NIJ based on the experience gained on an ongoing DARPA-funded project for detecting concealed explosive vests. During the DARPA project, we are building a variable focus phased array system for very long range detection. Hence, Luna proposes to use the experience gained on the DARPA project for building a street system (possibly handheld) for NIJ in a near-future proposal.

3. Detailed Description of Results

In the following sections, we describe in detail the various development stages of the project task wise.

4. Introduction

The development of a handheld, cost-effective, reliable street deployable system for the detection of concealed weapons from a stand-off distance of 5 meters is of great value to the security officials and law enforcement personnel. Recent reports have shown that Los Angeles loses the equivalent of three officers per week to injuries from offenders carrying concealed weapons. A handheld CWD device can be extremely useful when deployed in public places like malls, parks, schools, subways where potential hostage situations can be avoided. Another overriding concern in the criminal justice field is the safety of correctional officers from inmates. While there are several commercially available alarm systems for responding to an assault in prisons, the growing number of attacks on prison staff by inmates indicates room for improvements. For example, the Bureau of Justice reports 14,165 attacks on prison staff by inmates, with 14 deaths and a 32% increase in attacks in five years. Prison managers face additional challenges including identifying and screening visitors and the control of inmate movement. There is a growing need for new technologies that will aid in the safe

detection of handcrafted concealed weapons made from items such as toothbrushes, alarm clocks, pens and razors.

Non-acoustic devices have serious limitations detecting plastic weapons, are not cost effective and have complex hardware implementation. While some imaging techniques provide high resolution pictures of a person carrying a hidden weapon in real-time, they raise serious privacy concerns due to anatomically precise images and radiation exposure. Other limitations include speed of testing, real-time implementation, detection at a distance, outdoor noise and portability issues. Conventional acoustic methods have the disadvantage of attenuation at higher frequencies and a large beam width at lower frequencies, which limits the ability to detect small weapons (like guns, knives, plastic or ceramic blades, box cutters etc.) from long stand-off distances. The work presented here is a team effort to develop a non-linear acoustic weapons detection tool for stand-off detection in street systems and a closer range wand system for the corrections institute. In the following sections, we discuss the concept, theory and its relevance to CWD and discuss the major findings of this project. Appendices of results supporting our findings have been submitted with this report.

The goal of this project is to explore acoustic sensing for use in concealed weapons detection by augmenting traditional pulse-echo detection with nonlinear

acoustics and other signal analysis technologies. The ultimate objective is to design and build a CWD system that will function at an acceptable stand-off distance, be cost effective, highly automated, and robust and generates data that is easy to interpret.

5. Non-linear Acoustic Concept

Luna's concept for nonlinear acoustic concealed-weapons-detection uses high frequency multiple ultrasonic beams to carefully isolate a small inspection region on the person and assess the acoustic impedance of that particular region. When two high frequency waves, f_1 and f_2 combine at high sound pressures, the resulting sum signal driving the transmitter will undergo self demodulation as it propagates. This results in the generation of additional frequency components at the integer multiples of the sum and difference of the original frequencies ($nf_1 \pm mf_2$).

Since the absorption of acoustic energy in air is frequency dependent, as the acoustic wave propagates, the higher frequencies are quickly attenuated and the difference frequency ($f_1 - f_2$) becomes the dominant frequency present in the acoustic wave. However, because the resulting acoustic beam's directionality is determined by the transducer size relative to the original high frequencies f_1 and f_2 , a very narrow sound beam at the low difference frequency ($f_1 - f_2$) can be achieved.

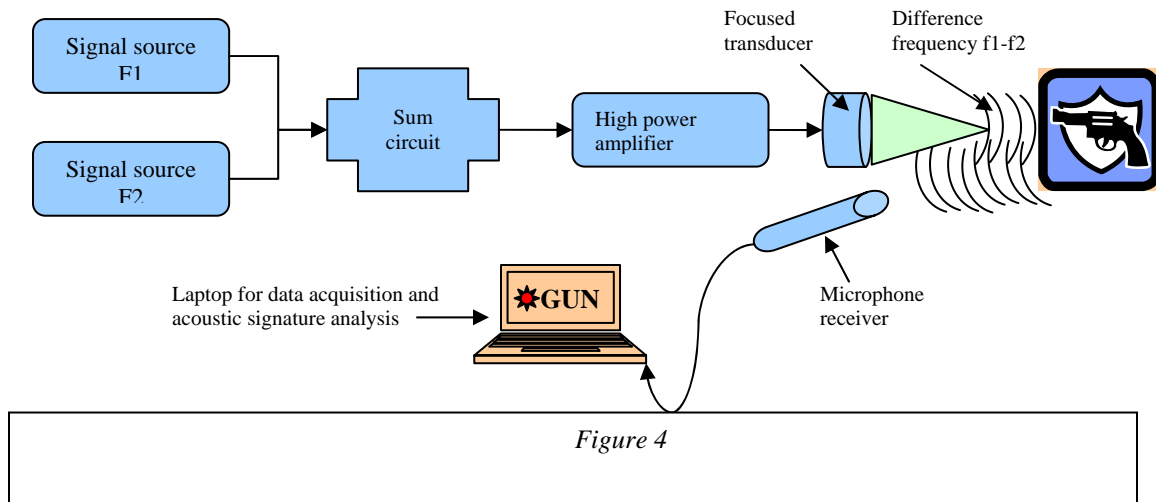

Figure 4: Experimental set-up for conducting non-linear acoustic parametric beam mixing.

Using this concept, a nonlinear ultrasonic system has been developed to provide an enhanced capability for detecting hidden weapons over traditional ultrasonic examinations. In the set up shown in figure 4, when the modulated signal is radiated from a *focusing* source, the difference-frequency sound generated due to acoustic non-linear propagation is concentrated at the focus. Thus, a small size low-frequency probe beam can be realized by setting the two frequencies close to each other.

An alternate configuration to generate a low frequency sound beam in a localized spot is by crossing two ultrasonic beams at the area of interest. Luna has done comparison tests under a Phase I project funded by HSARPA to determine the best method to produce the desired beam width and output sound pressure level at a 15 foot distance and findings have proved that parametric array design for the transmitter is most efficient. Hence, all data that is included in this report were results generated using parametric beam mixing technique.

In both methods of generation, we have found that spectral analysis of the received low frequency signal provides the best method for detection and identification of the concealed weapon.

One of our early tasks during this project was modeling the propagation of the mixed ultrasonic and audio beams and later improving these simulations to study

the interactions of the beams with concealed objects. The Khokhlov-Zabolotskaya-Kuznetsov (KZK) equation is the most widely used wave equation to model nonlinear acoustic beams. It accurately models the combined effects of nonlinearity, absorption, and diffraction. Lee and Hamilton developed a finite difference method based on the KZK equation to model pulsed acoustic emissions from axial symmetric sources. Using a similar underlying concept, a model was developed to visualize the wave front of an amplitude modulated signal as it undergoes non-linear audio generation in air.

As an example, we present the results of two simulations of the same parametric configuration with different degrees of nonlinearity in figure 5. The first simulation uses the appropriate coefficient of nonlinearity for air ($\beta = 1.2$) and the second does not include any nonlinear effects; at each distance shown on the left, the plot is split horizontally with the nonlinear simulation on top and the linear simulation on the bottom. A 2 ft diameter transducer with a geometrical focus of 8m is excited with a short pulse that contains two frequencies: 45 kHz and 55 kHz. The initial sound pressure is 120 db. Each waveform is recorded at 2m intervals starting at the face of the transducer and extending to 10m. At 0m, both ultrasound frequencies are present. As the wave propagates away from the transducer, the ultrasound is quickly absorbed due to the viscosity of the air.

As can be seen from the plot, the nonlinear and linear (upper and lower) plots are almost identical until 6m where the ultrasound frequencies are attenuated and the difference frequency becomes the dominant frequency in the nonlinear simulation. This unambiguously shows that the creation of the difference frequency is a result of the nonlinearity of air.

Parametric Pulse Propagation – Nonlinear Vs. Linear

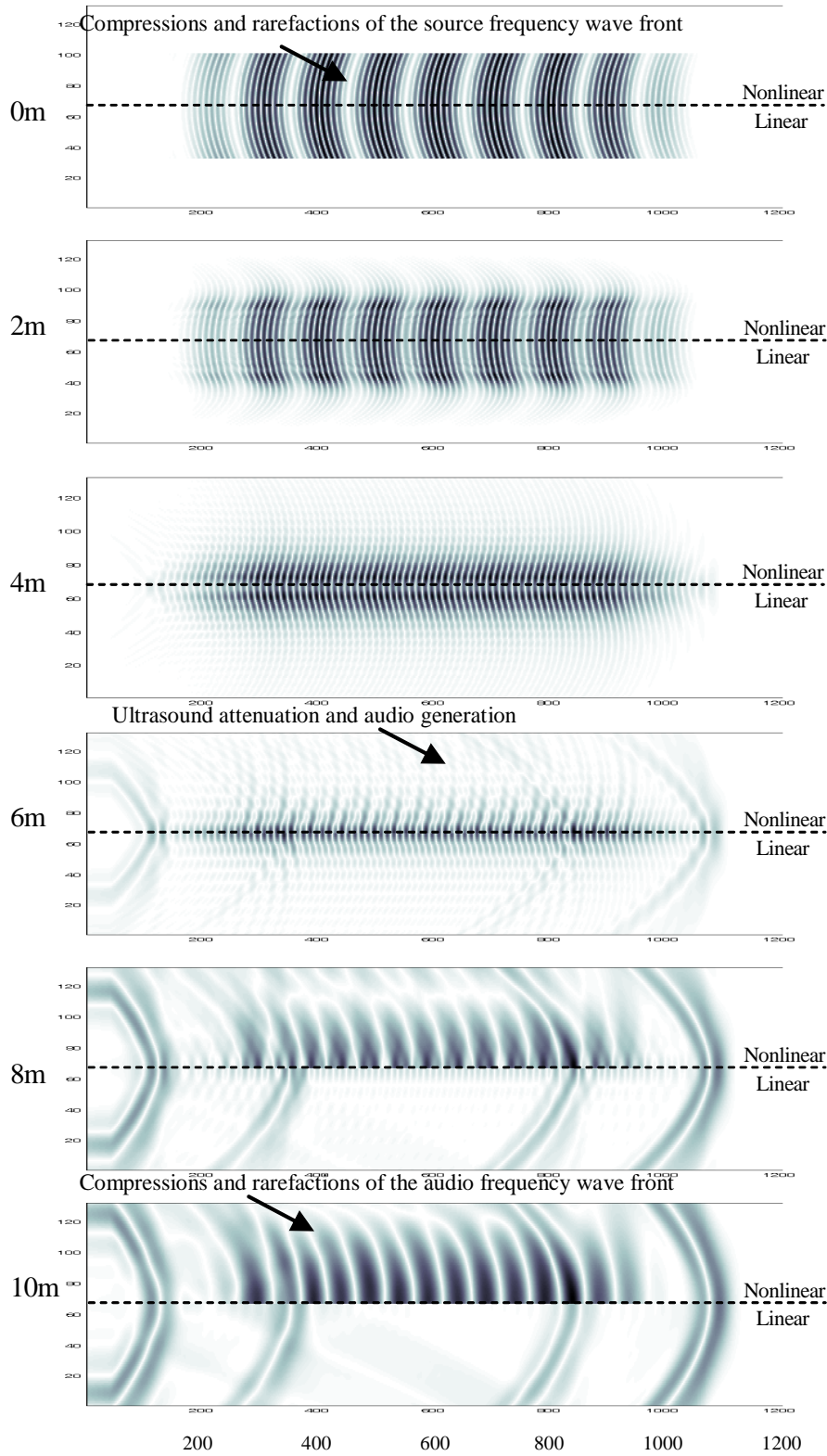

Each of the plots above is a representation of the sound intensity at the distance from the transducer (indicated by the number). X-axis represents time and Y-axis represents radial direction

Figure 5: Theoretical representation of sound pressure field for a non-linear vs. linear pulse propagating away from the transducer.

6. Near Range Scanning

a. **Lab Simulated weapons testing:** One of the first major successes on this project was the demonstration of the contrast between weapon-simulating metals and tissue-simulating gelatin media through non-linear beam mixing. A ballistic gelatin media was cast into a human torso shape to simulate a human body. An image of a simulated weapon on a simulated human body was achieved through a mechanical scanner. These tests use high power focused transducers operable at 140 kHz to generate a spot size of 5 mm at a distance of 14cm.

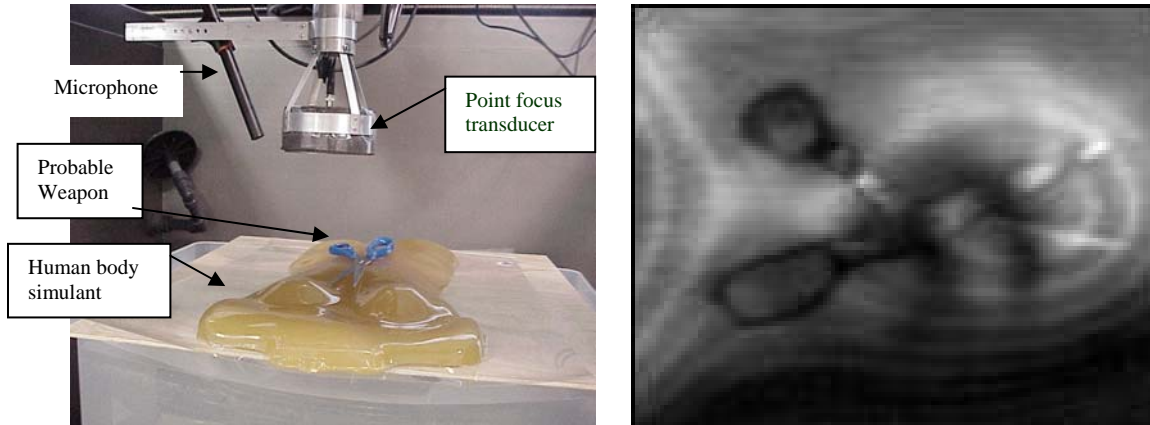

Even though the weapons were not concealed in this case, this method provided the resolution which is not possible without the non-linear approach. **With the experience gained from this work, we had very good success in detecting improvised weapons that were concealed under fabric as shown previously in Figure 2 and below in Figure 8.**

Figure 6: Near range image showing the contrast between weapon and non-weapon. The image area corresponds to a small portion of the sample target.

The 140 kHz point focus transducer was excited with mixing frequencies f_1 at 140 kHz and f_2 at 148.4 kHz. The measurement was the scattered acoustic signal from the target at the difference frequency which was $f_1 - f_2 = 8.4$ kHz. This probing frequency has a wavelength of ~ 4.5 cm and the resolution of the image is far beyond that. The image data above was generated from a test conducted in the CW mode where a short duration time-gate could not be set up for seeing the weapons from through the clothing. With the experience gained from the above tests, we improved hardware to detect improvised weapons that were completely hidden under layers of fabric.

b. **Scanning of improvised weapons received from NIJ/Corrections Institute:**

The image result shown in figure 6 provides a preliminary proof-of-concept of the superior focusing and resolution of parametric arrays. Following this proof-of-concept, a more rigorous set of scans were conducted on the real weapons shown in figure 7. These weapons were received from Mr. Clair Bee at the New York

State Department of Corrections. For all subsequent scanning tests using the non-linear acoustic approach, the experiments were set up such that the presence or absence of a weapon could not be detected visually, a test that most closely simulated an actual real life target.

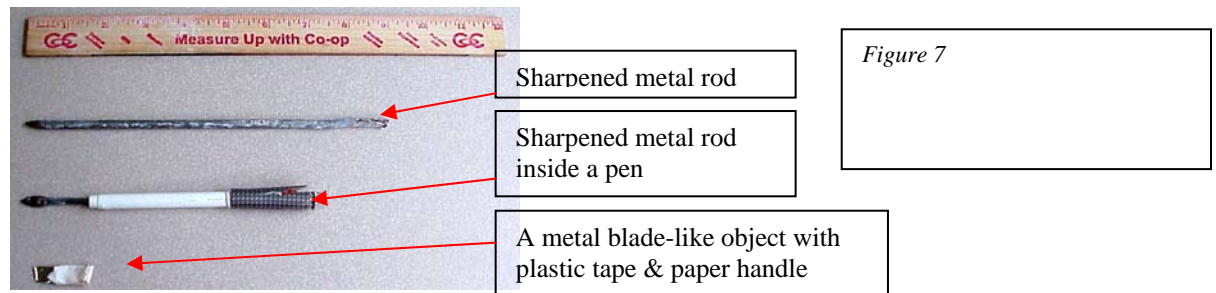

Figure 7: Improvised weapons made by inmates (Courtesy National Institute of Justice).

To enhance resolution, these scans were conducted in the pulsed mode using two 20ms-long high frequency beams of 140 and 147.5 kHz. The combined beam generates a 7.5 kHz difference frequency that can penetrate clothing and produces echoes from the hidden object sufficiently strong to be received by the microphone.

In these tests, we optimized the orientations of both, the transmitting transducer, and the receiver microphone to enhance reception of the acoustic echo from the

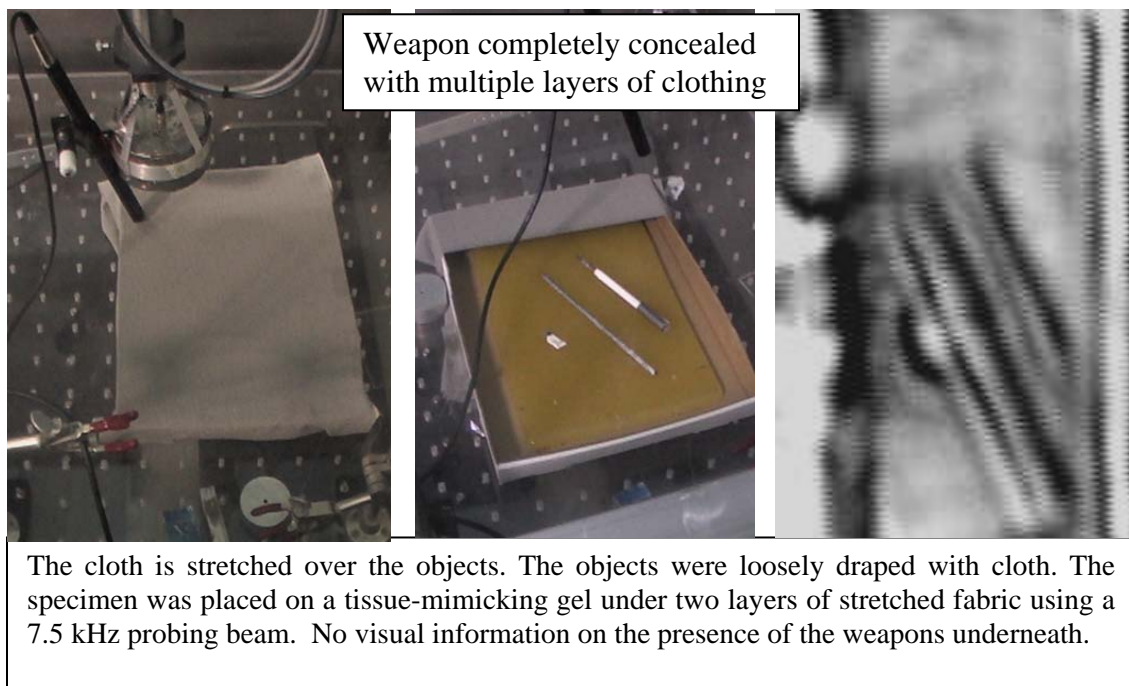

Figure 8: Non-linear acoustic scanning images of three weapons covered with two layers of fabric.

hidden object. Figure 8 shows the set-up of the concealed weapons scan. Two layers of thin fabric were covering the test articles such that there was no visual evidence of an object underneath. The arrangement of the objects on the tissue-mimicking gel pad is also shown in the figure. While the transducers, scanning hardware and the electronics were kept the same, the image of the scissors, generated in the CW mode, was analyzed in the frequency domain and the images of the improvised handcrafted weapons were processed in the time-domain. The rightmost picture in figure 8 shows the time domain C-scan image of the three hidden objects. The image was acquired when the double-layered cloth was placed about 0.5” above the weapons. The image resolves all three hidden objects.

The above experiments show the feasibility of short-range detection of concealed weapons through scanning, by a focused, parametrically excited low-frequency acoustic beam. A low-frequency acoustic beam can be used for high-resolution imaging, if it is produced by the mixing of two high-frequency beams. The resolution is not compromised when the simulated and the real weapons are placed on a human tissue simulator and are hidden under several layers of fabric. As a result of this demonstration, we have also developed guidelines for further improving the technique and moving it to the next stage – a hand-held “wand” for security screening. Even though a practical implementation of a wand would not allow a slow imaging type scanning, we believe we can extract acoustic signatures of weapons, on the fly, in the form of sweep scans.

7. Long-Range Scanning

The ultimate goal of this effort was to design and build a CWD system that will function at an acceptable stand-off distance, be cost effective, highly automated, robust, and easy to interpret. As an interim step, after discussions with TPOC, we have decided to build a 15-foot stand-off detection capability that can most logically be extended to a handheld system. The major steps involved in long-range concealed weapons detection are described in detail in the following sections.

- a. Transmitter Design
- b. Receiver Design
- c. Chirp Signal Generation
- d. Experiments with Focused Transducers
- e. Tests on Lab Specimens
- f. Tests on Real Guns
- g. Database development for classification
- h. Addressing False alarms

Many commercial parametric array-based speakers are out on the consumer market for audio applications including targeted advertising and localized museum soundtracks. They include the HyperSonic Sound of *American*

Technologies, the Audio Spotlight of *Holosonic Research Labs* and the Audio Beam of *Sennhieser*. All of them use somewhat different forms of ultrasonic transducer arrays and transmitter electronics, but operate under the same parametric array principles. The sound beams produced by these speakers are roughly 1 meter beam-width at a distance of 15 feet and operate at audible frequencies around 2 kHz depending on the diameter of the transducer.

a. Designing Transmitter with a Fixed Focus for 15-foot detection:

Working with the College of William & Mary, we have developed a simulation code using the KZK equation to model non-linear acoustic beams and visualize beam patterns. The preliminary results obtained from using the commercially available speakers are included in the Appendix A. Using the near-range detection results obtained using the focused 140 kHz ultrasonic transducer, model predictions were made to design a focused transducer that can produce the same output at 15 feet.

In order to validate the model prediction, experimental results obtained with the long-range unfocused transducers were compared with the simulated data for the same transducer size and operating frequency. As an example the following data shows a comparison between experimental and simulated results.

Simulated and Experimental Absorption Data Comparison

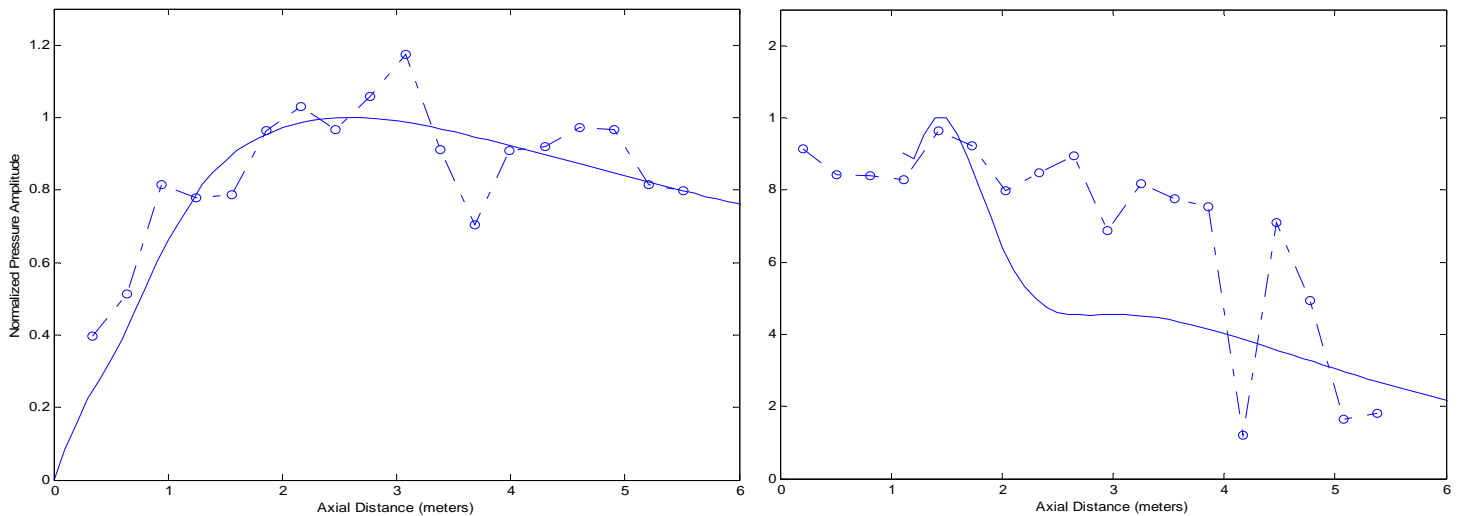

The solid line represents the simulated data and the dotted line represents the experimental data.

Figure 9. Simulated data showing the axial absorption plots for the audio (left) and ultrasound (right) components of the sound beam.

Simulated and Experimental Beam Width Profile Comparison

Audio – 8kHz

Ultrasound – 53.6kHz

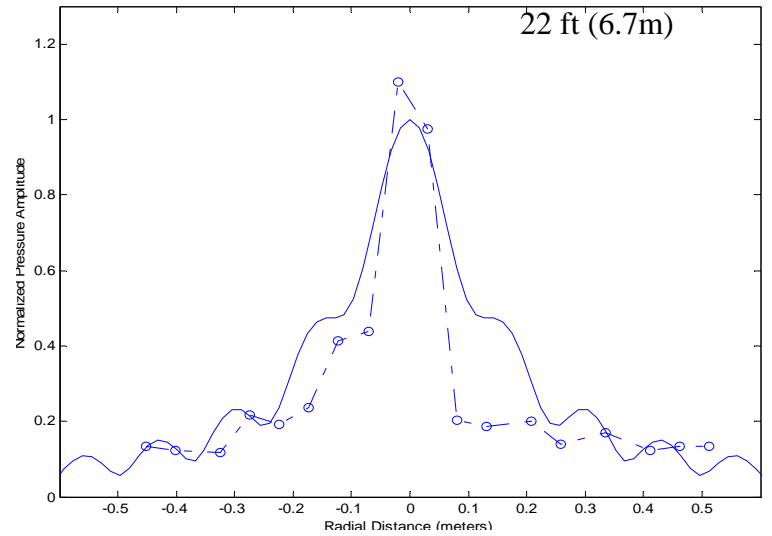
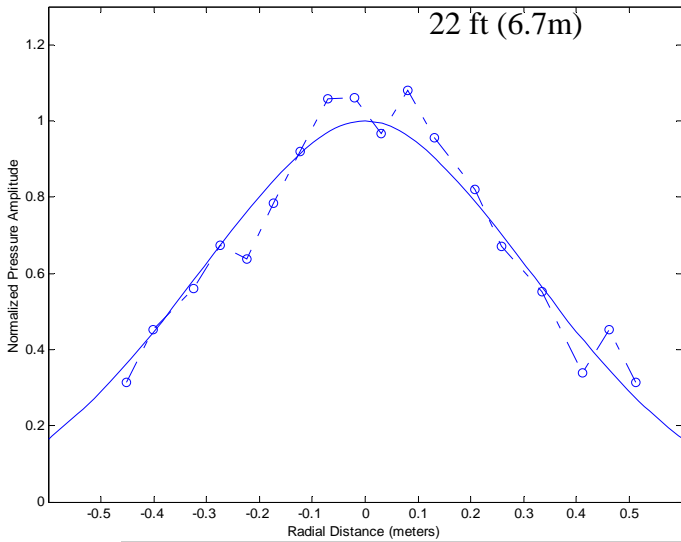
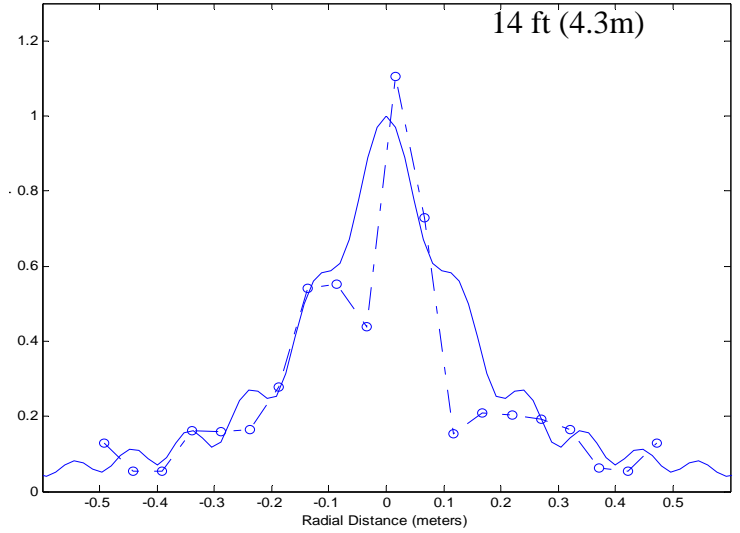
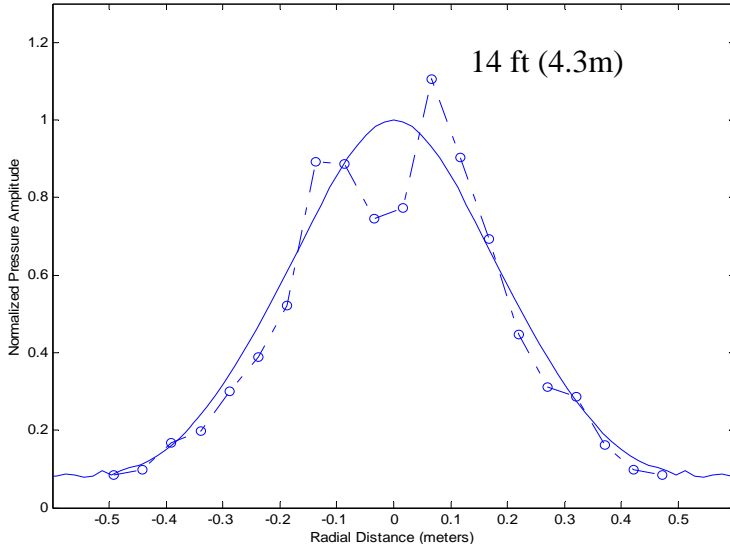

The solid line represents the simulated data and the dotted line represents the experimental data.

Figure 10. Simulated data showing beam-width profiles for the audio (left) and ultrasound (right) components of the sound beam measured at various distances from the parametric transducer.

8000 Hz Component of Acoustic Beams for the Flat and Focused Transducer

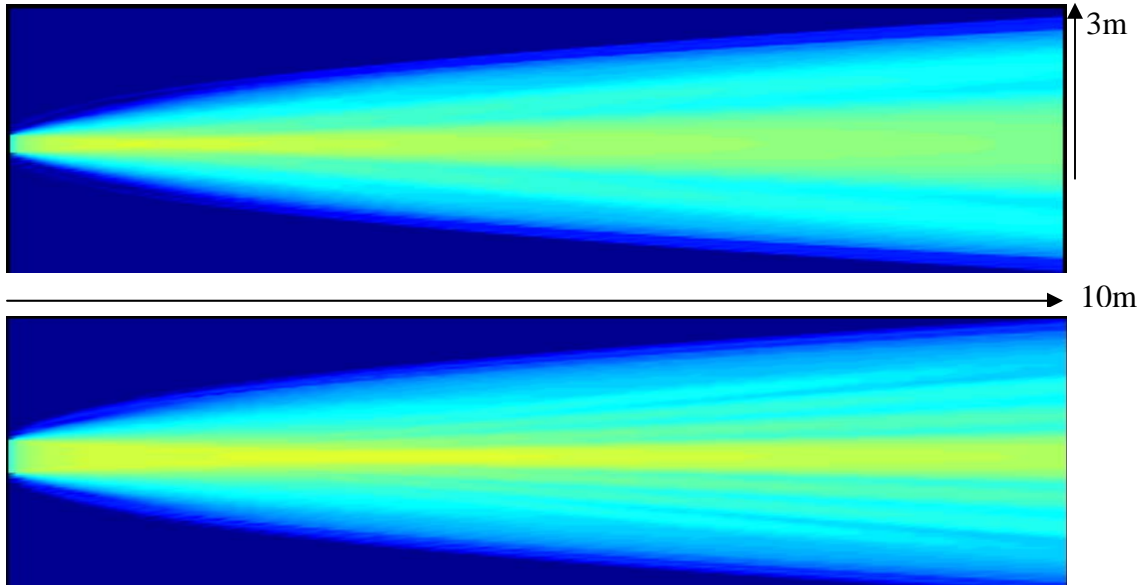

The transducer is located at the left of the figure. The color represents the pressure intensity in decibels.

Figure 11. Simulated 8000 Hz component of the acoustic beams created from a 1 ft diameter flat transducer (top) and a 2 ft diameter focused transducer (bottom).

As can be noticed from the previous figures, the predictions of the model coincide closely with the experimental observations. We decided to modify one of the unfocused Audio Spotlights to build a focused transmitter. Hence, similar simulations were conducted to come up with the curvature and desired input power needed for successful CWD at 15 feet. Using the data predicted by simulations, the curvature and diameter parameters designed for the transducer were shared with transducer manufacturer at Holosonic Research Labs.

Characterizing the Focused Transducer: Sound Pressure and Beam width

After receiving the focused transducer, the first step was to characterize the spot size in terms of beam size (related to weapons size) and sound pressure level (for exciting the target at its resonance). Experimental set-up showing the focused transducer and a calibrated microphone positioned 15 feet apart to study transducer performance are shown in the following figure.

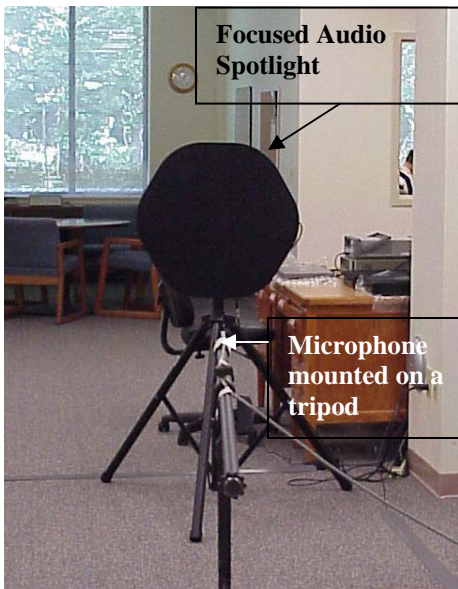

In this set-up, a microphone was mounted on a tripod and positioned at the focus of the focused transmitter. This was done to characterize the spot size of the acoustic beam. It was found that the focal spot was approximately 12 inches and the focal depth was 16 feet. The experiments in this transmitter-receiver configuration as shown in figure 12 provided useful input for designing a dish receiver.

Figure 12: Experimental set-up showing the beam characterization at 15 feet for a focused audio spotlight.

The target size of most weapons that were to be tested was less than 12 inches. As a result of these beam characterization studies, we confirmed that this transmitter was suitable for insonifying the objects of interest.

In figure 13, we show the ultrasonic intensity (at 66.4 kHz) and the beam spread at 15 feet from the face of the transducer.

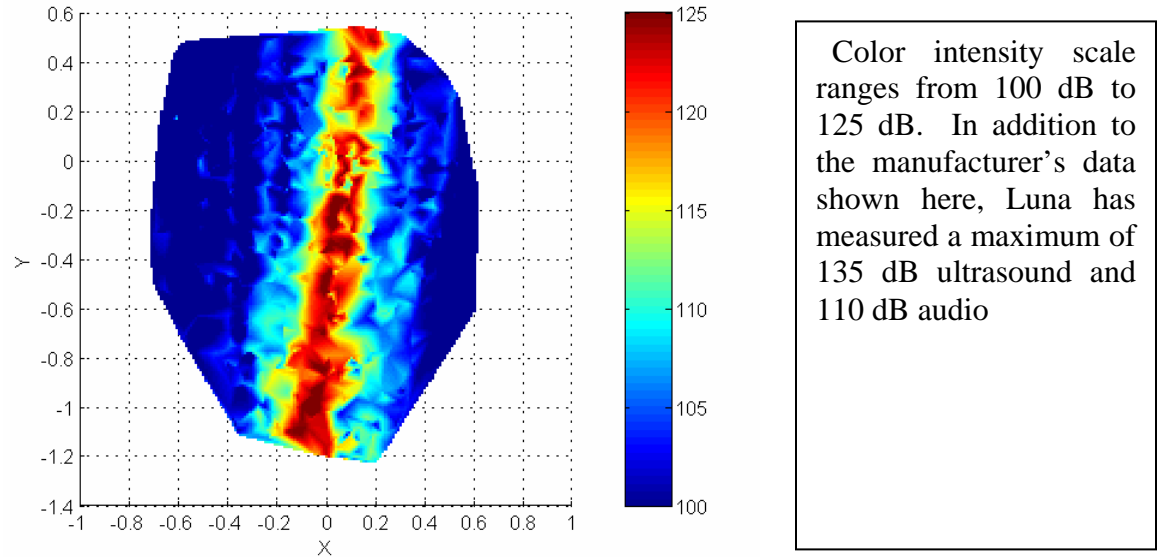

Color intensity scale ranges from 100 dB to 125 dB. In addition to the manufacturer's data shown here, Luna has measured a maximum of 135 dB ultrasound and 110 dB audio

Figure 13: A plot of calibration data for ultrasonic sound pressure amplitudes with the xy origin at 15 ft.

We have conducted many preliminary studies using an unfocused transducer while building the 15 foot full-scale concealed weapons detection system. In addition to being able to reduce the beam width from 3.5 feet to 1 foot, the important advantage of designing a focused transducer was the increase in sound pressure impinging on the target.

A comparison of the measured sound pressure level between focused and unfocused transducers is shown below.

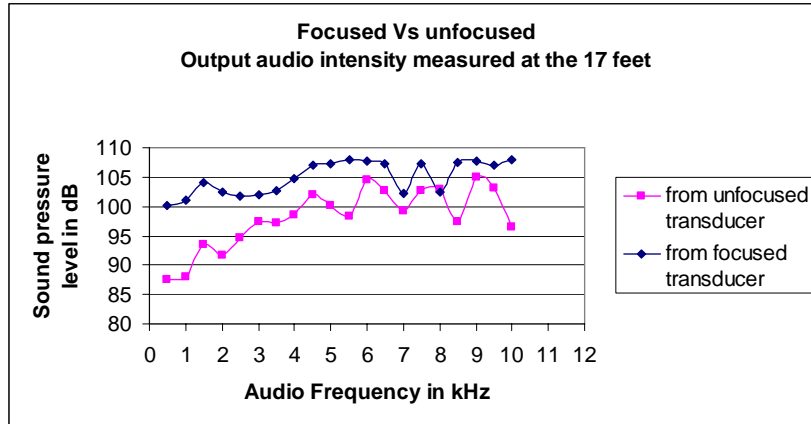

Figure 14: Experimentally measured focused Vs. unfocused output audio intensity measured at 17 feet.

As can be seen from the above figure, focusing the beam could increase the sound pressure level on the target at which the tests were conducted.

b. Fabricating the Receiver Dish

Initial testing was done using a commercially available parabolic receiver microphone. However, since the focal zone of a parabolic receiver is infinite, the commercially available parabolic receiver microphones were NOT optimized as receivers, for the current CWD transducer which has a small focus spot. A receiver dish was designed and fabricated in house for acoustic signal pick up from 15 feet. A B&K series 4939 sensitive microphone was placed at the focus of an elliptical dish. The dish was elliptical in shape and made of light weight fiber glass cloth. The elliptical shape permitted the microphone to be placed at one of its foci, the dish being positioned such that the other focus was same as the interrogation zone where the transducer was aiming (on the person with a weapon). The elliptical dish can be visualized as a portion of an ellipsoidal shell. Various stages in the fabrication of the dish are shown in the following pictures.



In the adjacent picture, a fiber glass cloth is being glued onto a foam-machined elliptical mold, the profile of which is optimized for a 15 foot focus. This dish is much larger than required for field use but will provide important data for design analysis.

Figure 15: A picture of the elliptical receiver dish mold under fabrication is shown here.



The other focus of this dish is 15 feet away at the target location. This permits the choice of selecting a small spot on the target

Figure 16: A picture of the elliptical receiver dish with a sensitive microphone at its focus.

c. Chirp Signal generation and Data Analysis

Having designed the hardware, the next step in conducting the weapons detection tests required the use of some sophisticated signal generation to extract the acoustic signature of a target.

Some of the considerations in determining the type of signal included

- a. **Multiple frequency** generation since different objects resonate at different frequencies
- b. **Short duration signal** since the target location and features are not masked by surrounding acoustics
- c. **Varying amplitude** so that the transducer fall off response can be accounted and the entire signal was of constant amplitude
- d. **Eliminating specular reflections** so that the size and orientation effects were minimized to extract the true acoustic signature.

Time-frequency based correlation algorithms and FFT based algorithms provide the user with options to analyze data in multiple ways. Particularly, a chirp signal was found to be best fit into the needs of CWD. A sample data from unfocused transducers is shown in the following figures.

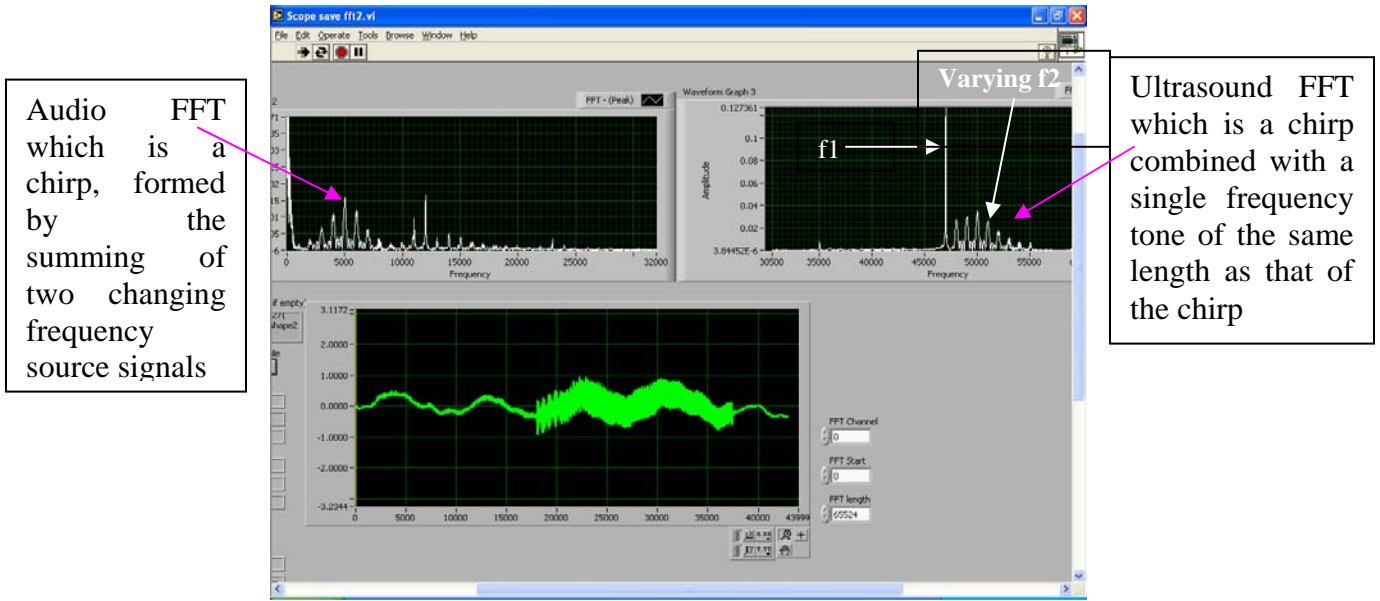

Figure 17

Figure 17: NAC signal received from a specimen covered with clothing and **no** weapon underneath.

The picture shown in figure 17 is a screen shot of a signal recorded through a chirp signal excitation propagated 20 feet to a distant target and received from the same distance. The green curve shows the short duration time-domain signal reflected off of an absorbing background (to simulate tissue) covered with clothing. The two plots on the top are the FFT of the signal received in the audio range and the ultrasonic range respectively.

There is a weapon (plastic gun) under the blue fabric



Figure 18: Experimental set-up for concealed weapons detection using the parabolic receiver dish and the Hypersonic Sound transmitter.

Audio FFT which is a chirp formed by the summing of changing frequency source signals

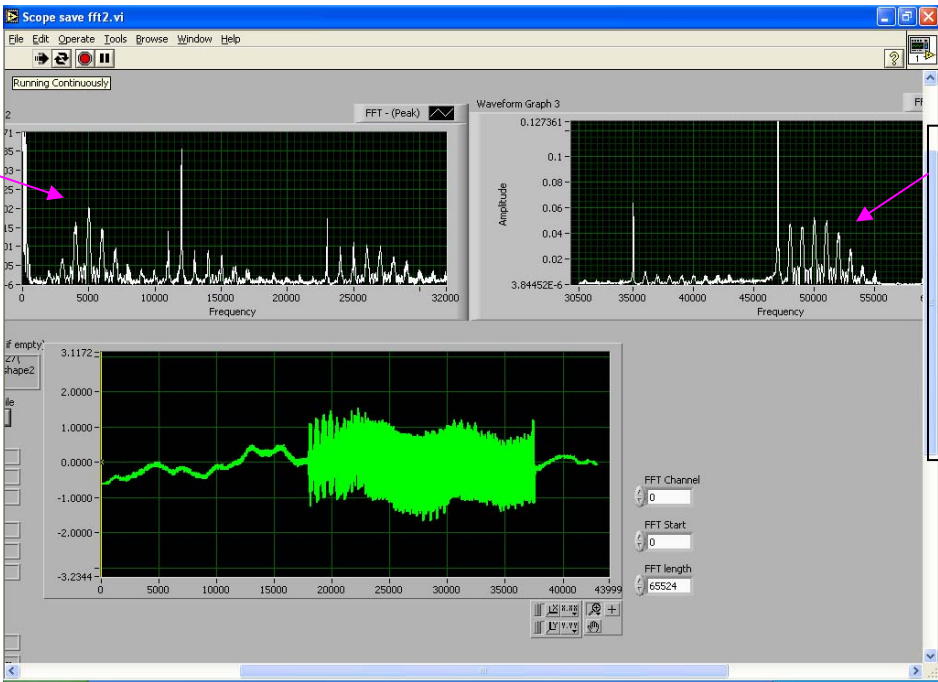

Ultrasonic FFT which is a chirp combined with a single frequency tone of the same length as that of the chirp

Figure 19: NAC signal received from a plastic gun covered with clothing.

If one compares figure 17 & 19, the amplitude of the signal is increased from a weapon and additional frequency domain content. Such a signal will be processed through a time-frequency analysis to isolate spectral frequencies features from a weapon in a spectrogram presentation.

Data sets such as the ones shown in figure 19 were used for analysis in the time-frequency domain to separate data from a gun and data from a non-weapon or a no-gun case.

d. Experiments with Focused Transducers

This evaluation test was useful in creating the multiple frequency chirp signals tailored to the bandwidth of the transducer. The following figure 20 shows a chirp that has been tailored for a linear frequency sweep, with the amplitude modified to adjust for the frequency response of the amplifiers and transducers

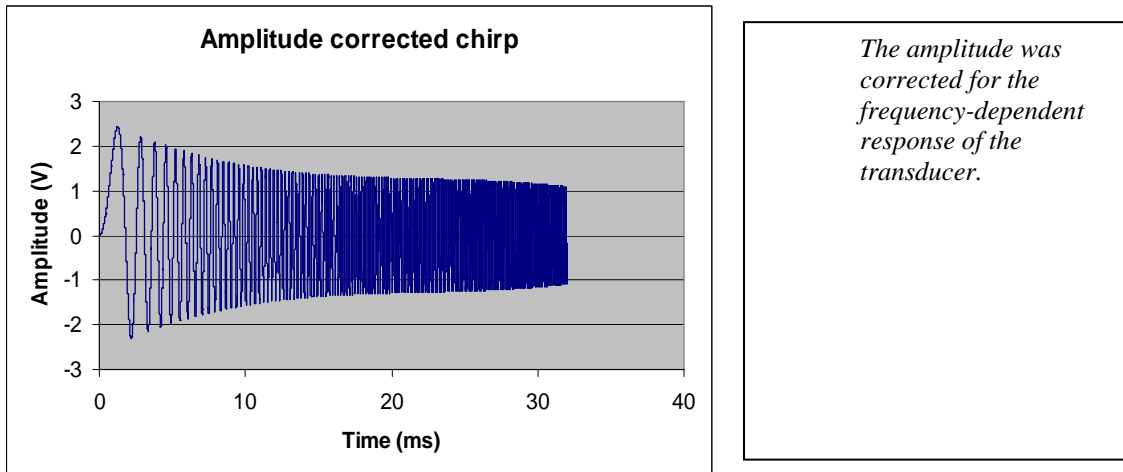

Figure 20: A 32ms chirp signal created such that the source frequency chirp is starting from 0.1 kHz to 10 kHz, increasing linearly though the chirp.

e. Tests on Lab Specimens

After deciding the input signal type, we selected a few lab specimens as weapons simulants before we were able to acquire the real guns (shown in later sections)



Figure 21: Weapon simulants used for testing and developing analysis algorithms

In the following tests we:

- Tested 5 known weapon cases under thick clothing for studying their signatures

1. Scissors
2. Plastic Gun
3. Cell phone
4. Box Cutter
5. Nail cutter/ Pocket Knife

- Eliminated room noise and mounting effects through post processing (technique describe in Appendix A)

- Tested three unknown cases and analyzed incoming chirp signals (weapon was behind a thick coat)

- Employed correlation algorithms from the database of weapons' signatures

- Box cutter and Scissors were rightly classified as hidden weapons

The pictures with the person holding a weapon behind the clothing are as shown below.

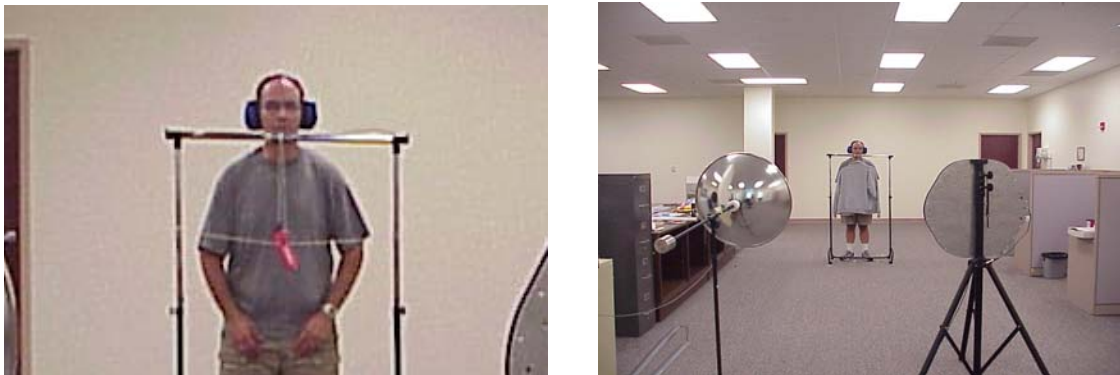

Figure 22: Pictures of experimental set-up for detecting signatures through thick clothing

Table 1 provides a summary of two unknown weapons that were tested from a database of signatures that contained acoustic features of objects including scissors, a box cutter, a cell phone, a plastic gun and a pocket knife. The values in the table are the correlation coefficients obtained after matching the incoming test signals with the signatures in the database. These objects are approximately half the size of the beam, at the focus. When recording the database, care was taken to measure the acoustic signatures of these weapons with a direct incidence of the input chirp signals on the weapon. The return signal was recorded with by the microphone. For each weapon, several signatures were generated and averaged. When testing the unknown cases, two weapons from the database of six weapons were selected for running correlation algorithms. The unknown weapons were concealed behind a thick coat 4.5m away from the transmitter and receiver.

Table 1: Weapon classification result summary for three unknown objects

Comparison combination	Box cutter	Cell phone	Pocket Knife	Plastic gun	Scissors	Metal tube
Unknown1	0.5252	0.2872	0.1493	0.4213	0.3383	0.2269
Unknown2	0.03366	0.0155	0.0832	0.0373	0.2057	0.0228
Unknown3	0.3413	0.0192	0.0798	0.1356	0.3392	0.0468

The actual weapons that were concealed behind the thick coat were unknown1 = box cutter; unknown2 = scissors; unknown3 was a combination of box cutter + scissors. **These results indicate that objects that belong to a class of weapons can be distinguished from non-weapons like cell phones.** The low values indicate that the database needs to be improved.

To make the results appear pictographically, for easy interpretation, we decided to display the chirp signal in the form of spectrum (joint time-frequency plots). In the spectrogram plots shown below, even though the input chirp was a linear continuous chirp, the return signal from the tube behind the thick coat had resonance features, shown clearly in the spectrogram. These bands in the spectrogram are separated by a frequency that coincides with the resonance frequency of the tube.

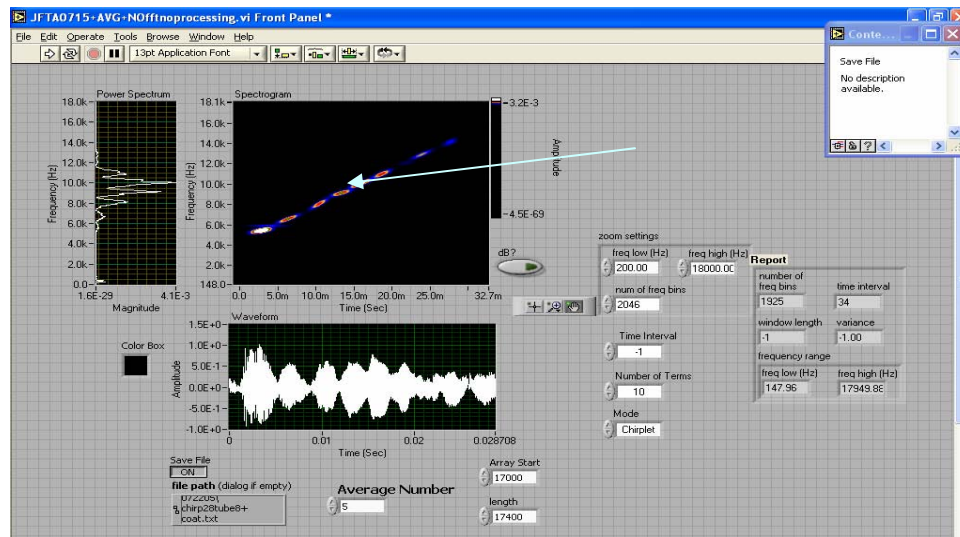

Tube behind the coat

Figure 23: Acoustic signature of a tube showing various frequency bands separated by tube's natural frequency

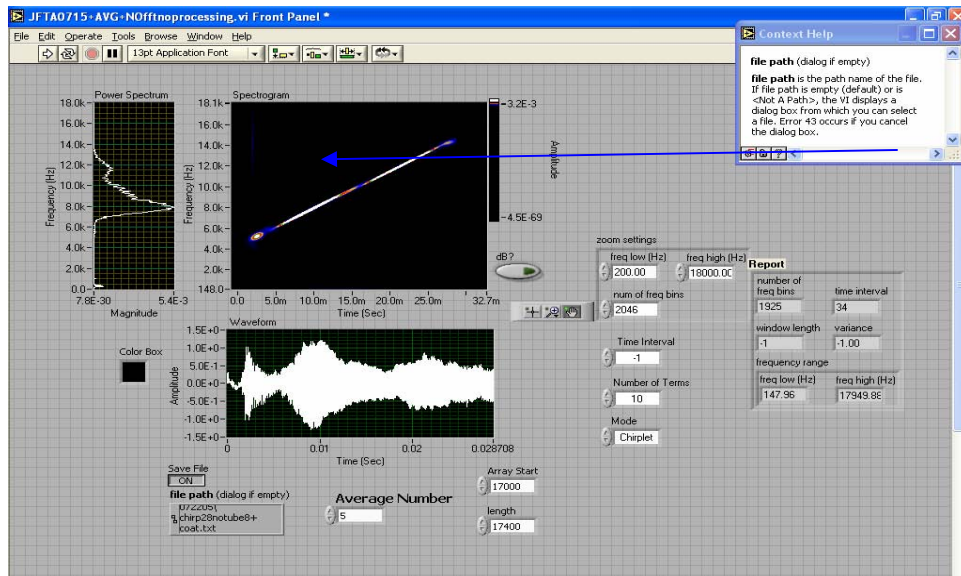

Figure 24: Specular or flat-plate reflection indicated by the flat line of the linear input chirp incident on the target

No tube behind the coat

From these results it has been shown that we can extract acoustic signatures from targets behind **thick clothing**.

f. Tests on Real Guns

In the data that follows, we have shown that we can acoustically detect **real concealed weapons and there are signatures that can be extracted**

All the following preliminary data on real guns was collected with:

- A person in the focal zone
- A weapon if present was tucked in the person's jeans such that a portion of the weapon was covered under his shirt and the remaining portion concealed under his denim jeans and the shirt on top of it.
 - The weapon was not visible from outside (i.e. it was NOT tightly hugging his clothes).
 - The person's position was adjusted with respect to the source and the receiver.

Experimental set-up, target and the weapons are shown in detail in the pictures that follow in figure 27.



Welded area meant to disable the gun

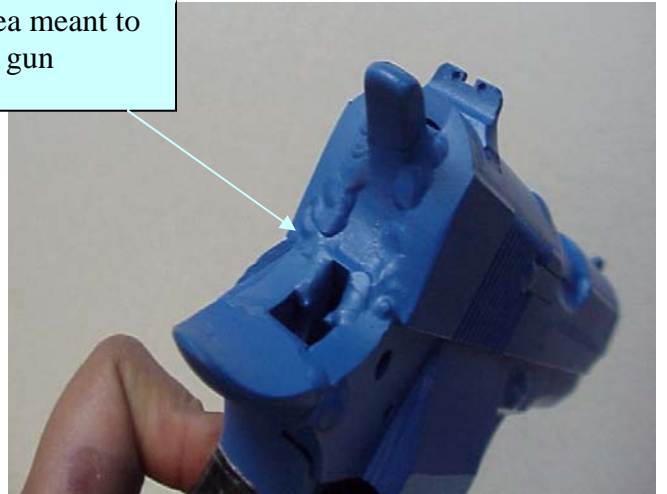

Figure 25

Figure 25: Pictures of real guns that were used for testing. Also shown are areas of welding where these real guns have been disabled

222579

MARK'S GUNSMITHING, INC.
 4640 CAMELLIA DRIVE
 SUFFOLK, VA 23435

757-483-
9229

CUSTOMER'S ORDER NO.		DATE	
		7/23/05	
NAME Luna Innovations			
ADDRESS Christopher Domak			
CITY, STATE, ZIP			
SOLD BY	CASH	C.O.D.	CHARGE
			# 3767
ON ACCT.	MOSE. RETD.	PAID OUT	
QUAN.	DESCRIPTION	PRICE	AMOUNT
1	The following 3 guns have been		
2	completely de-milled and		
3	Tig welded up. Guns are		
4	completely inoperable in any		
5	manner and are not considered		
6	guns by BATF definition.		
7	1 FFF Cap 25 Cal Guardian		
8	Ser # 668695		
9	1 Armi-Galosi 7.65 MRFSI		
10	Ser# 202802		
11	1 LAMA Mini Max II 9S		
12	Ser# 07-04-06168-97		
RECEIVED BY [Signature]			

4705 KEEP THIS SLIP FOR REFERENCE

Figure 26: Approval notice from a certified gunsmith showing that the guns are actually disabled

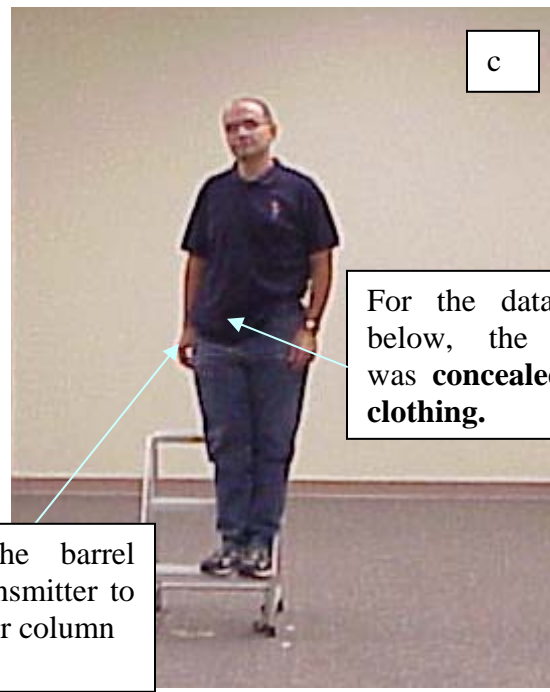
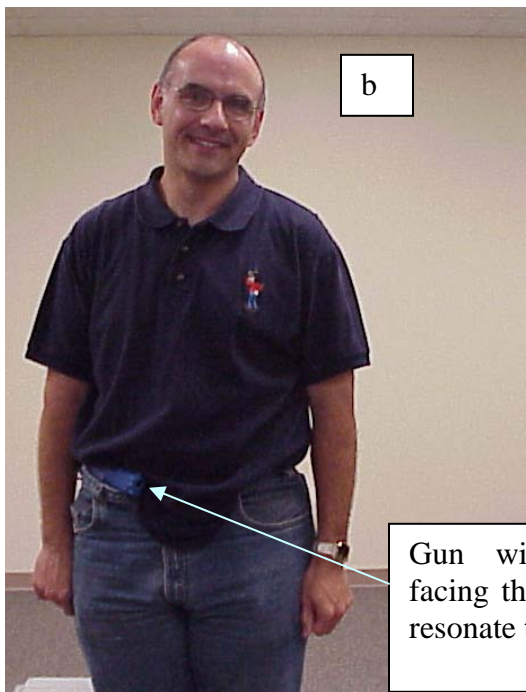
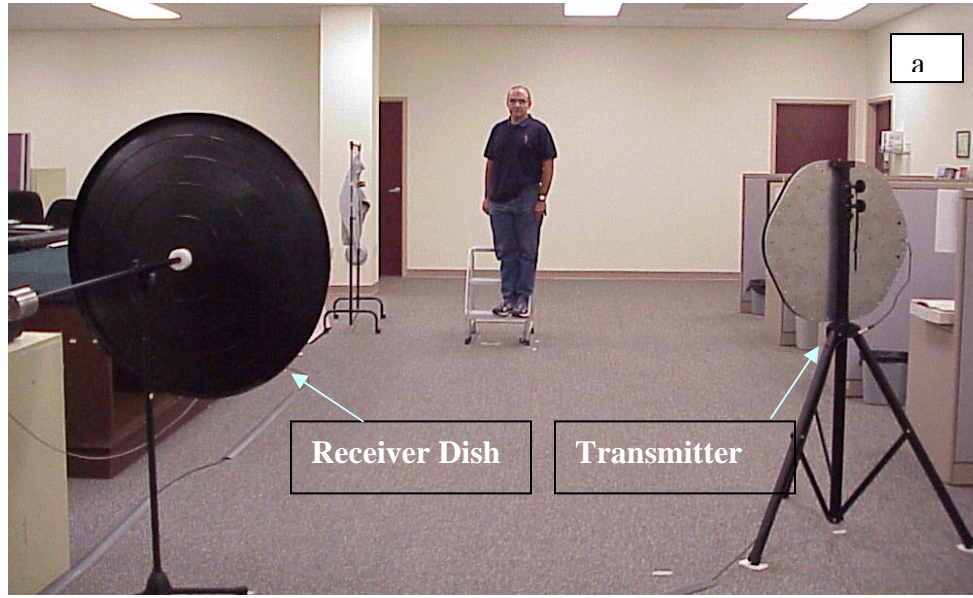

For the data shown below, the weapon was **concealed under clothing**.

Gun with the barrel facing the transmitter to resonate the air column

Figure 27: Pictures showing the experimental set-up and the use of the real guns as concealed weapons.

In the plots shown in case 1 to case 3 following this section, we show the time-domain, frequency-domain and simultaneous time-frequency spectrogram data. Variations in each case are obvious in all three displays.

- Highlighted are the things/features to notice in each of the plots to better read the spectrogram.

- A particular color band in the spectrogram is **not** comparable to the same color in another spectrogram (since the spectrogram display is set to auto scale)
- For these particular real-gun data sets, the classification was through visual interpretation of the spectrogram (by the operator).

Case 1: Person standing in the focal zone with **no weapon**

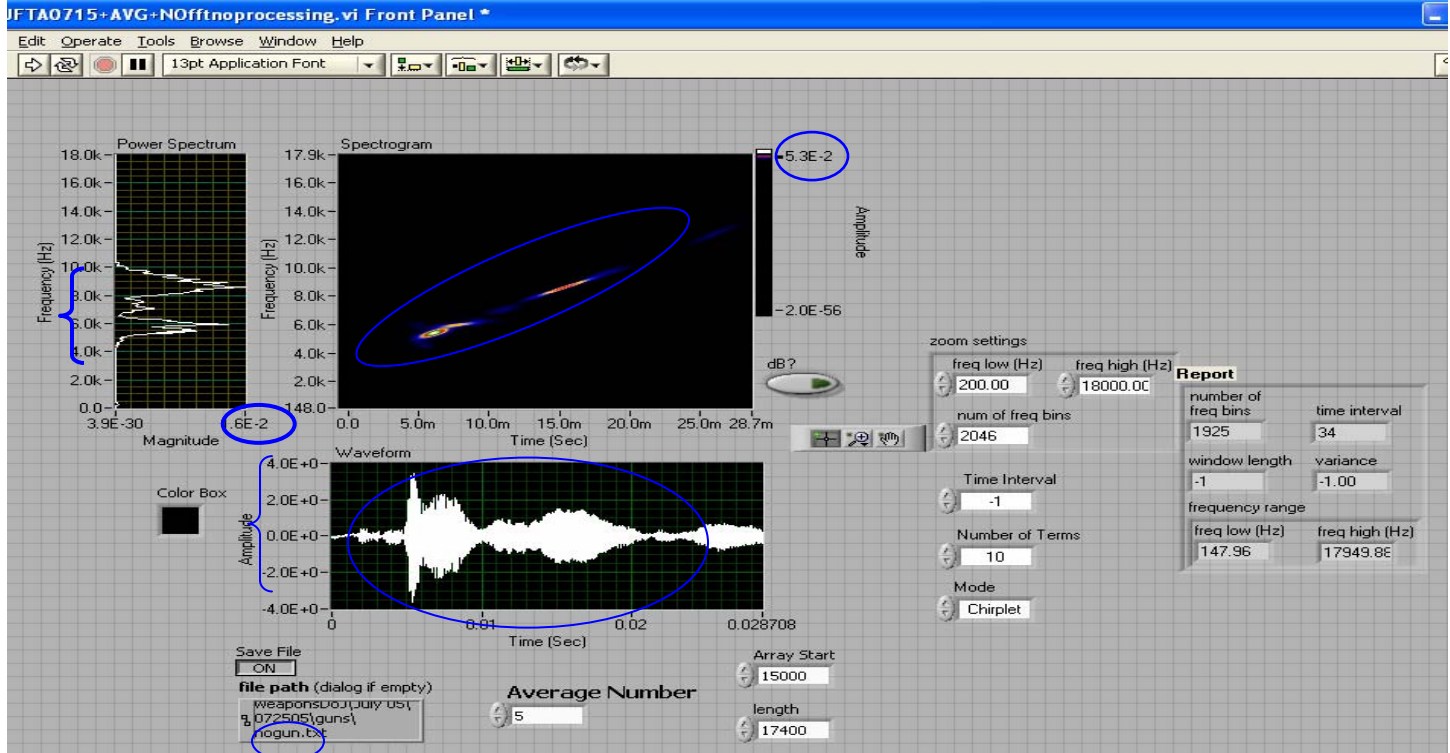

Case 2: **Hidden gun present**

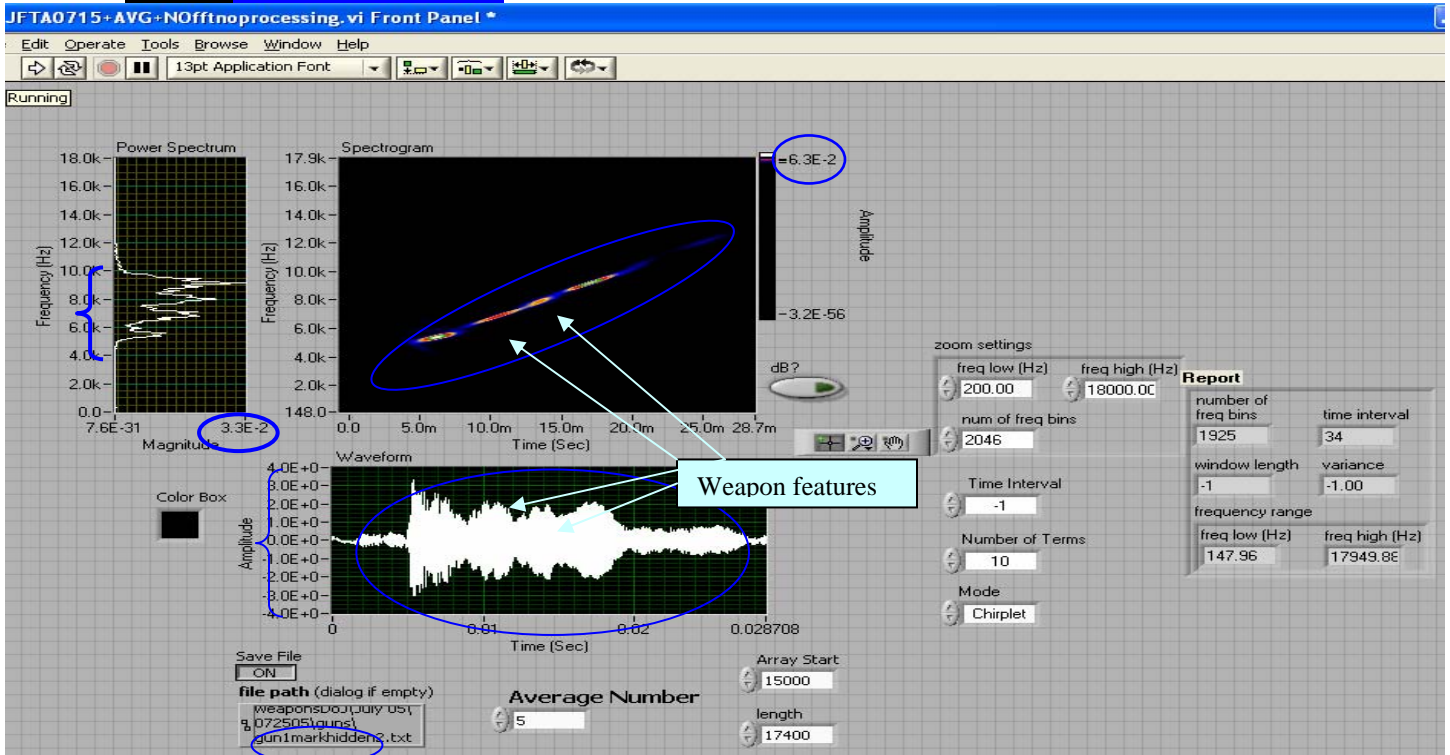

Case3: Unknown case – Correctly identified as gun being present

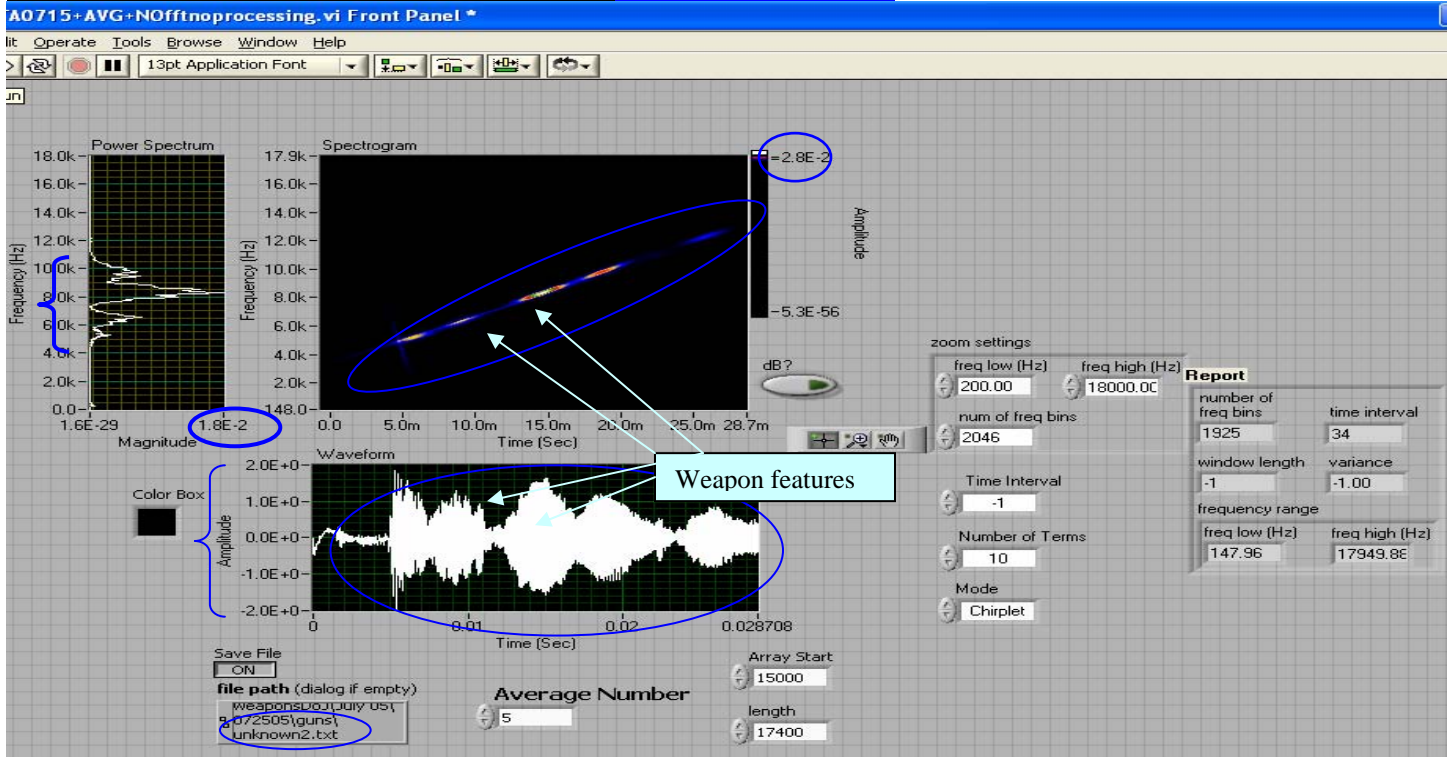

Case 4: Unknown case: Gun was present but the person turned away such that the hidden gun was not at the focus and detected as 'No gun'.

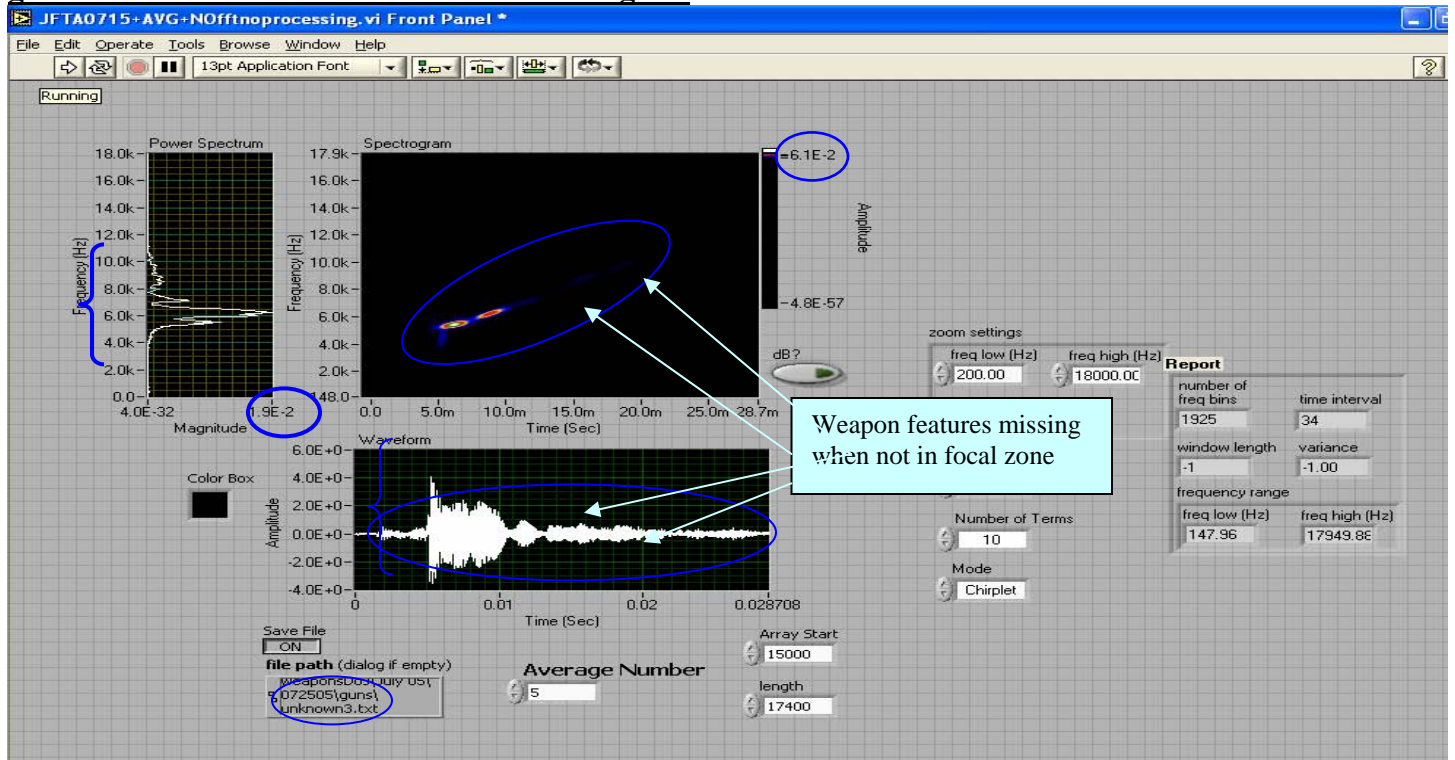

These results validate that the system is capable of detecting hidden weapons. The next step was to extend these results for a wide range of weapons and enhance visualization of the results. These test results showed a dependence on the weapon size and orientation. Hence we decided to develop a database of signatures not just for different types of weapons but also different positions of weapons on a person.

g. Database development for classification:

We recorded several sample signatures of the weapons currently being tested. This was done in two different rounds of tests. For the first round of sample signature extraction, each weapon was mounted on the stand and the chirp signal reflecting off of the object was recorded and saved. The weapon was un-mounted and re-mounted on the stand in the same position. Another signal was recorded and saved. This was repeated 10 times for one weapon. Averaging all 10 signals constituted the signature for that weapon. The same procedure was followed for all weapons and the database consisting of weapon signatures was developed.

Then, an unclassified weapon was placed in the focal zone (supported on a stand). This unclassified weapon was randomly chosen from the set of weapons under consideration whose signature was already present in the database. Chirp signals reflecting off of this unclassified weapon were recorded and digitized. Our algorithm compared the received signal with the signatures in the database and performed a correlation analysis. The results are as follows. In each of the following plots, the LabView front panel shows the result from the algorithm in the form of a level in the color bar and the picture on the right is the actual test weapon.

Offline processing for ensuring the quality of database

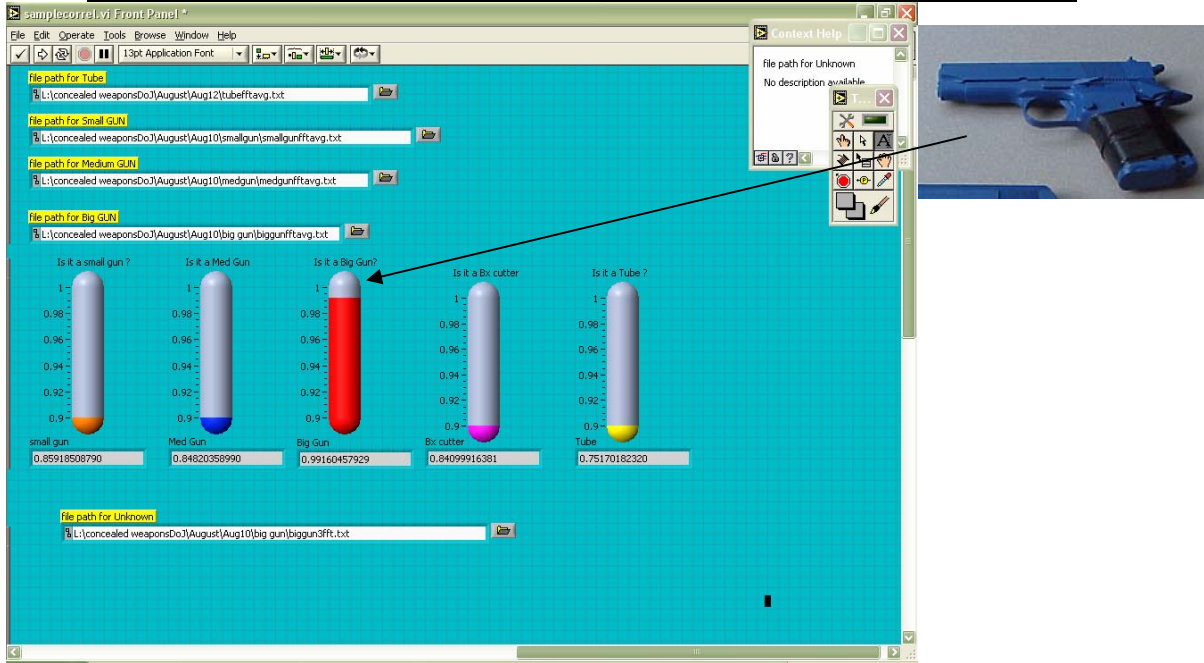

Figure 28: Offline correlation coefficient result for a Big gun. The resulting value of the coefficient was significantly higher compared to other objects.

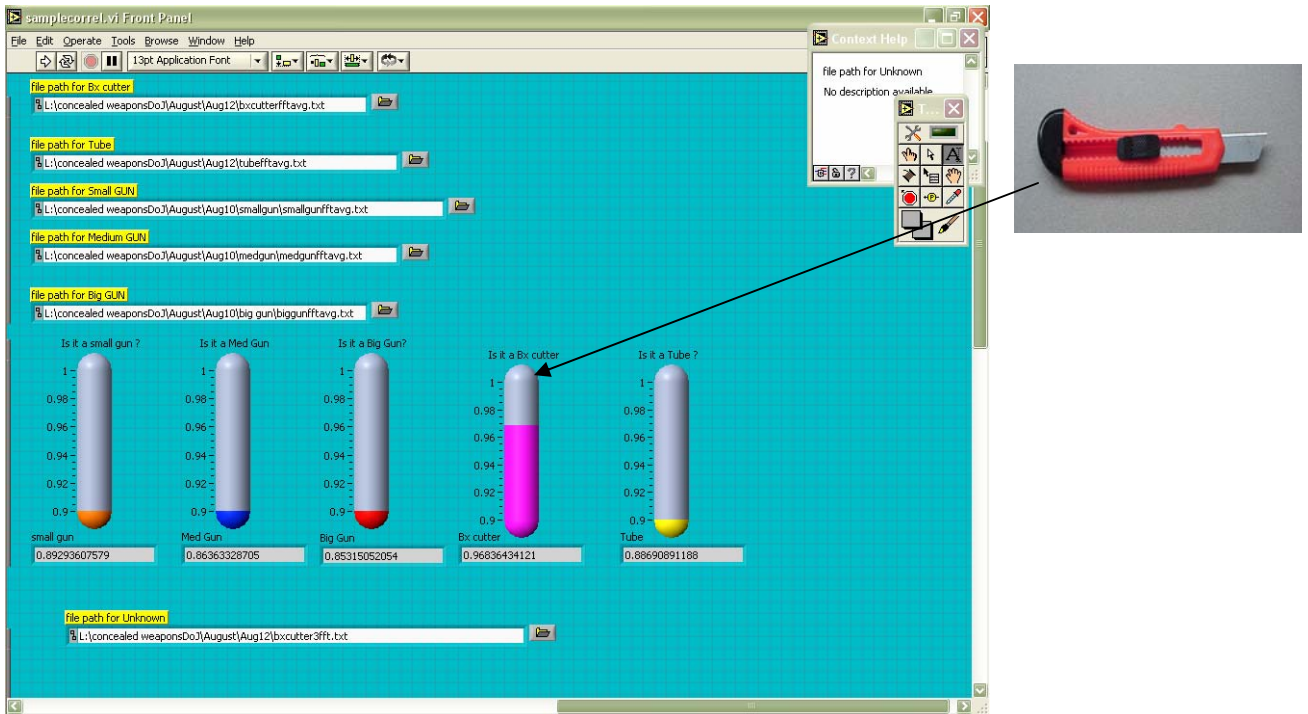
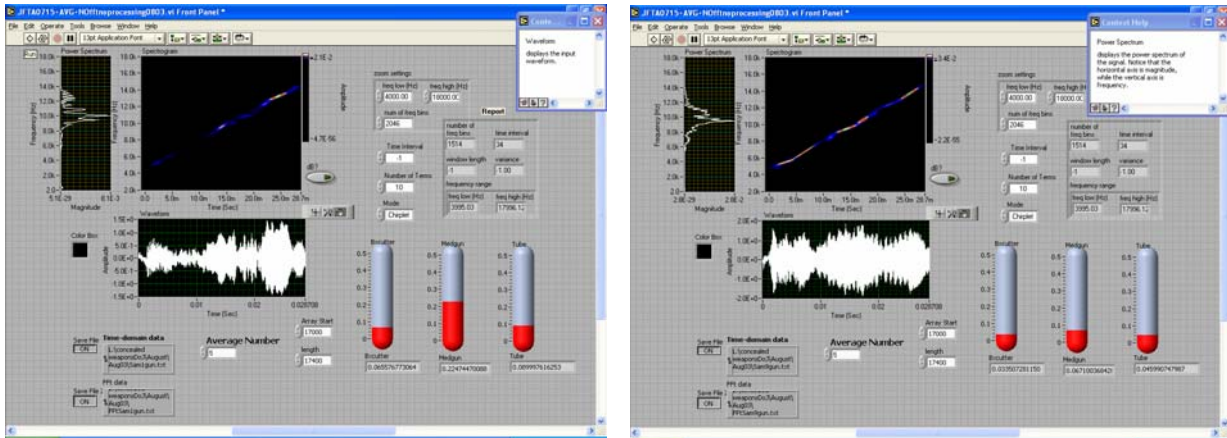

Figure 29: Offline correlation coefficient for a Box cutter (actual weapon). The resulting coefficient was significantly higher compared to other objects in the database.

The test results shown in figure 28 and figure 29 were helpful in **defining the mathematical correlation functions** suitable for CWD data. The results were extended for tests on people; however the weapon had to be positioned in the exact same orientation under the person's clothing. As an example, in the following picture, the weapon was hidden such that the barrel of the gun was pointing the transmitter.



In the left plot, the gun (middle color bar) was classified correctly indicated by a high correlation coefficient when its position was such that the barrel was facing the transmitter. When the orientation of the weapon changed, the classification result was less obvious.

Figure 30: Comparison of classification results for weapons in two different positions.

An interesting observation in the above plots is that, even though the spectrogram provides visual information regarding the frequency content of the return signal, it does not help in a decision making situation where the weapon can be assigned to particular class of objects. Hence the improvement from spectrogram analysis to the correlation analysis proved to be an advantage. This also encouraged us to look at both the time-domain data correlation and FFT domain correlation such that a combination factor that accounts for the 'z' position and acoustic response of the target both produced a maximum likelihood of the right classification.

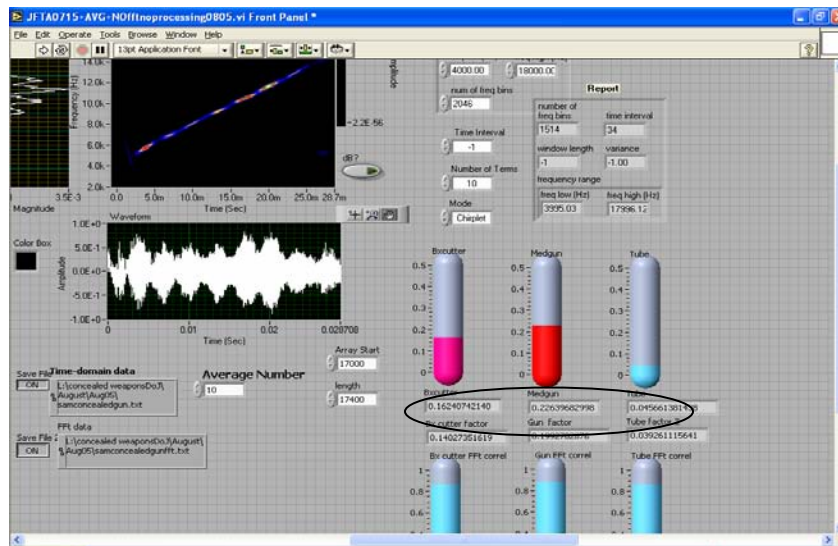

In this figure, the effect of both time-domain and FFT domain correlation put together correctly detected and classified the gun hidden in a random position under a person's clothing.

Figure 31: Combination of time and frequency domain correlation for improving analysis results.

h. Addressing False alarms: Orientation effects

The issue described in figure 30 was addressed by recording a second database that accounted for the various possible positions/orientations a gun can be carried on a person. This was done by changing the weapon orientation with respect to the transmitter for each of 10 sample signatures recorded for a particular weapon. These signals were later averaged to get a single signature for the weapon. Following this improvement, the weapons were hidden in the person's pocket for all further tests. Various clothing types were used and the weapon was not visible to the eye when concealed.

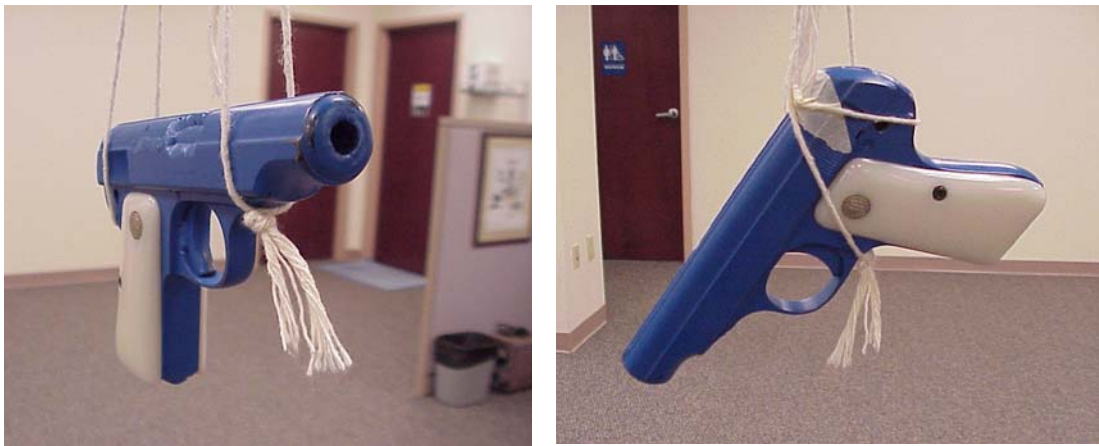
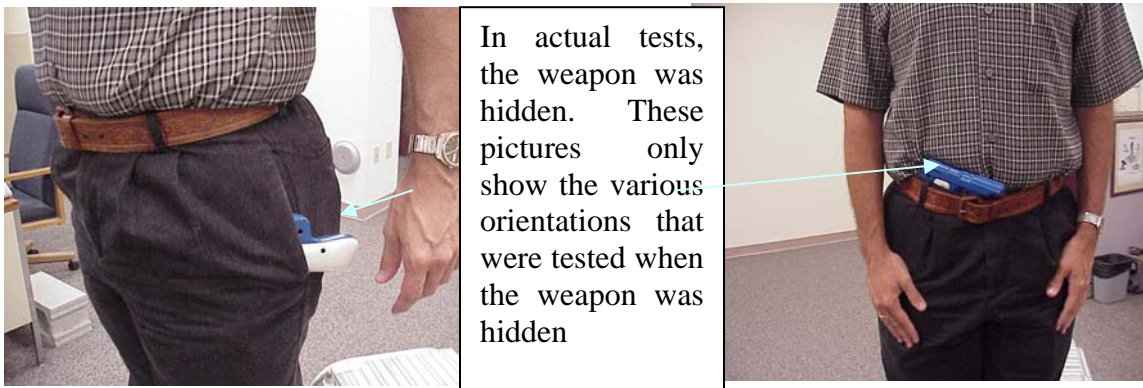

This procedure was repeated for all the objects that were tested.

Figure 32: Pictures of two of the several different positions in which the weapon's signature was recorded for the database.

Isolation of specular reflection from resonance features to address size of the weapon:

In the correlation analysis technique, the specular reflection was a factor for large targets, where a majority of the incident signal returned back to the receiver due to reflection from a flat edge/surface. This huge signal masked the acoustic signature specific to the weapon and hence the chances of the weapon being classified were small in certain positions.

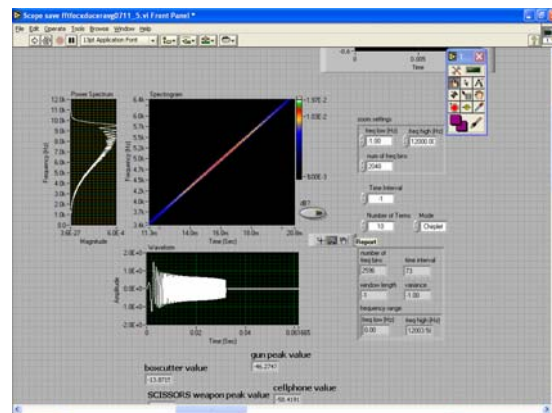

Figure 33: Input chirp signal, with a varying frequency structure over 32 ms time, designed to resonate a wide range of objects.

In order to address this issue, the incident chirp (shown in figure 33) was subtracted from the return signal after normalization. This removed the back reflecting specular chirp. The result was verified by looking at the FFT. A similar technique was employed in removing the acoustic signature of the stand on which the test objects were mounted for the database set.

After several of these modifications, the LabView code was tested a few times on different objects to ensure that these changes helped improve the results. Also, the number of real weapons that were analyzed was increased to five weapons and hence we had to record some more signatures for the new test objects. In all tests that followed, the weapons identified were much more obvious and the angle at which the weapon was oriented was less of a problem.

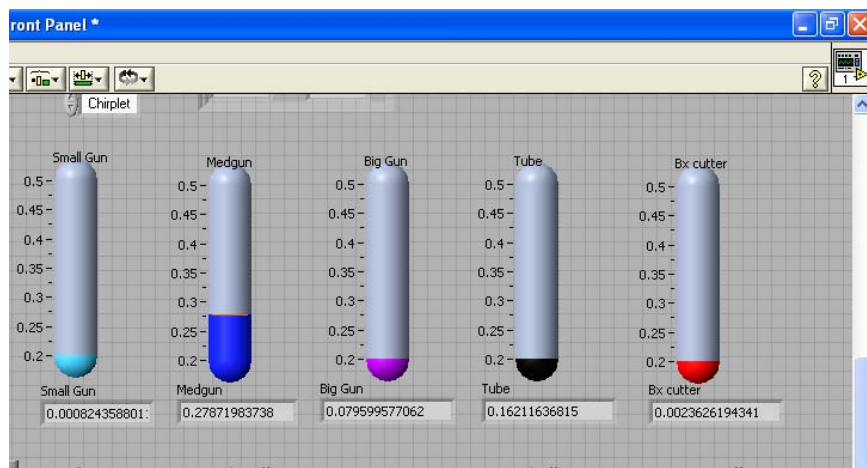

Figure 34: A medium size gun (blue has highest correlation coefficient) that was classified correctly with the improved analysis technique

i. Signal Analysis Algorithms:

The basic signal analysis behind the correlation analysis is a simple cross correlation of both the time and the FFT data of an unknown incoming signal with the signatures in the database. Each incoming signal was averaged over 5 multiple chirps before being analyzed further for classification.

In constructing the database of signatures, we first recorded the time domain signal from a stand (used to mount the weapons) and then from a flat plate mounted on the stand. For each incoming signal from the weapon, we subtracted from it the time-domain and FFT data of the stand. Next, we removed the specular reflection by normalizing and subtracting the FFT data of the flat plate. This constituted a signature for a particular weapon. This pre-processing was done for all the weapons in the database. For any CWD test, the final decision making metric was the product of the cross-correlations of the time waveforms and the FFT waveforms of the unknown signal with those in the database.

While building the database, each weapon when mounted on the stand was oriented in many different positions and an average signal was used for further processing. That way the detection result was not influenced by the orientation weapon. In the course of analysis for the HoloSonic Audio Spotlight system, we have found that the first chirp is distorted as the DC bias on the electrostatic transducers is developed in the matching networks. Therefore, we have discarded the first chirp signal and the last chirp signal in a train of chirps. An adaptive representation of the spectrogram (LabView inbuilt function) was used for the time-frequency display. We have considered algorithm development using Wavelet Analysis and are currently beginning to develop codes in Matlab using 1-D wavelet packets.

8. Long Range detection: LabView user interface.

Software modifications were made to improve analysis results on the weapons detection system. The results are now displayed in the form of images on the LabView front panel. In the following figures, sample results showing the display of the weapons are shown. We believe that this is a much simpler representation of the results.



Figure 35: Experimental set-up for CWD tests on people, with improved software

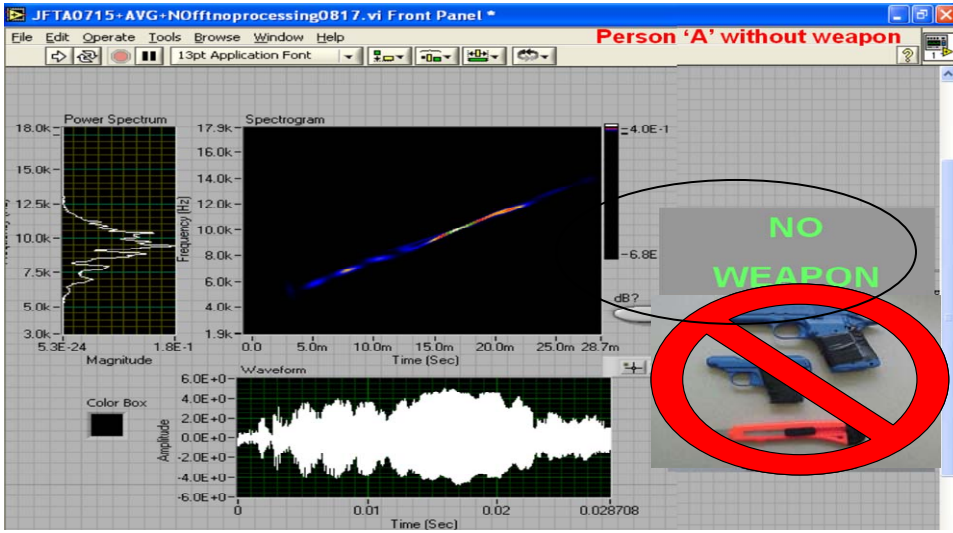

Figure 36: Data analysis result with an image display for a case tested with “a person with no weapon on him”.

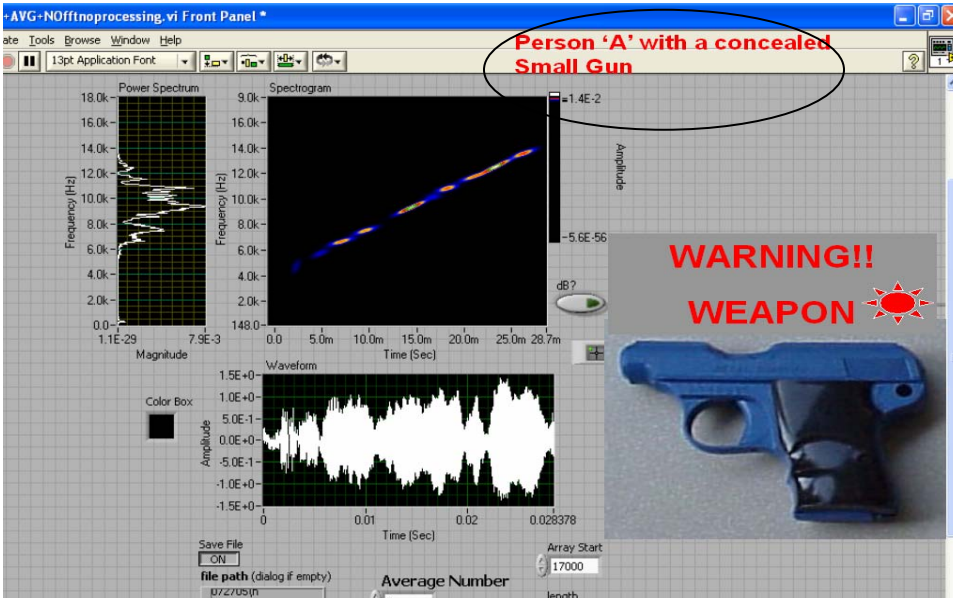

Figure 37: Data analysis result with an image display of weapon for a case tested with “a person hiding a gun as a weapon”.

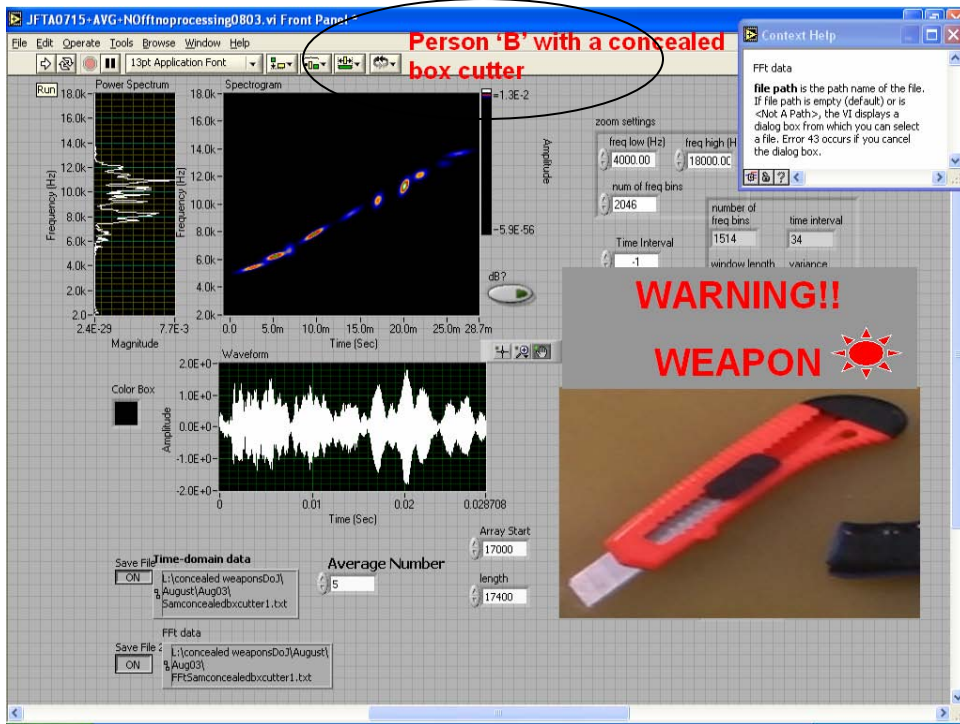

Figure 38: Data analysis result with a image display of weapon for a case tested with “a person hiding a box cutter as a weapon”.

9. Future Work:

a. Short Range Wand for Corrections

We have demonstrated successful results for CWD at a fixed focus using the spectral acoustic signatures for the weapons detection and identification along with the imaging results obtained from scanning improved weapons that were completely concealed under clothing. Due to simplicity of hardware and fewer variables occurring in a prison environment, Luna proposes to explore the concept of an acoustic wand for prison security as an immediate next step. We have received an excellent response from various key personnel in the corrections community. A formal proposal for development of such an acoustic wand in partnership with a leading metal detector company has been submitted to NIJ.

b. Phased Array Implementation

Having proved the concept and workability for a fixed focus system at 15 feet, the application of NAC technique for CWD in multiple situations is now hardware driven. A phased array-based dynamically focusing system with improved signal processing will be the final field deployable system that we envision.

For such a system, a transducer capable of controlling the beam shape through electronic phasing and delay set-up of the individual 128 elements of a transducer will be designed. Through a short duration on/off excitation, the transducer array can be used as both transmitter and receiver for handheld implementation. To reduce the need of 128 separate amplifiers, the approach being considered would drive multiple sets of elements with a single amplifier, perhaps in a ring pattern. However, to get an acceptable response at the low acoustic frequencies, it may be necessary to change which elements are used for the receiver array, requiring multiple transmit/receive switches.

A preliminary design from our DARPA project and description of the electronics is as follows:

This design for a phase array system uses an external computer such as a PC-104 embedded computer and a 25 MHz master clock to control 2 AD9959 4 channel direct digital synthesizer chips to produce an 8 channel phased array system. The programming on the AD9959 shows that the output frequency can be varied from 0.0058 Hz to 10 MHz with a 25 MHz input clock with 32 bit resolution. This allows precise control over the frequency. The phase of each of the synthesizer outputs can be adjusted with 14 bit control or 0.022 degree resolution. If a master 25 MHz clock is used to clock both output synthesizer chips and also used to gate each of the synthesizers, then all 8 outputs will be coherent. This sequence could be extended for more channels. The THS3001 amplifiers are output buffers to buffer the 1.8V outputs of the Synthesizers to drive the high voltage drivers. Not shown are the low pass filters for the synthesizer outputs, though they are

probably not required for frequencies below 1 MHz as any distortion will be centered around the 25 MHz clock frequency.

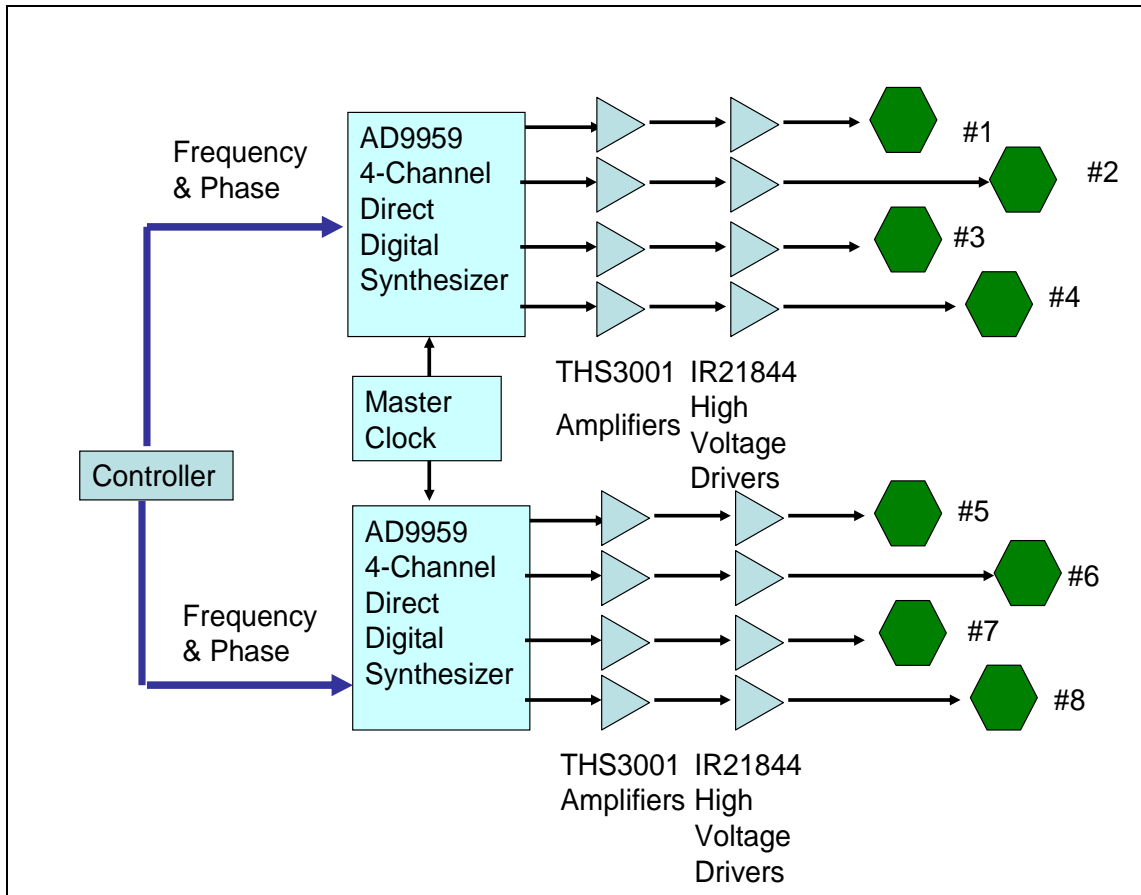

Figure 39: Schematic diagram for the phased array system proposed for future work. This is based on an ongoing project funded by DARPA

Output Drivers:

The IR21844 High Voltage Driver chip is a half-bridge design. The use is shown in Figure 40 below. Here the output can be as high as 600V peak to peak, driving two N-channel output MosFET devices. The HO output is the high-level drive for the floating FET and the LO output is the low-level drive. The SD input is a system disable device. The IN can be a TTL/CMOS level signal. The output can be disabled using the SD input to shut down the output. The IR21844 itself can source up to 1.4A but with a maximum power dissipation of 1W which would limit the load impedance to 18KΩ or an input capacity for the source follower output FET of 40 pF. The device right now could be run with an approximate duty cycle of 10%.

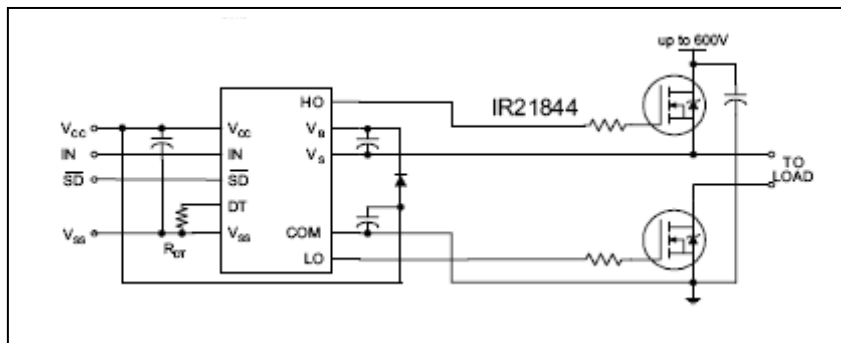

Figure 40: Output connection for high voltage drive on transducers for the proposed phase array system

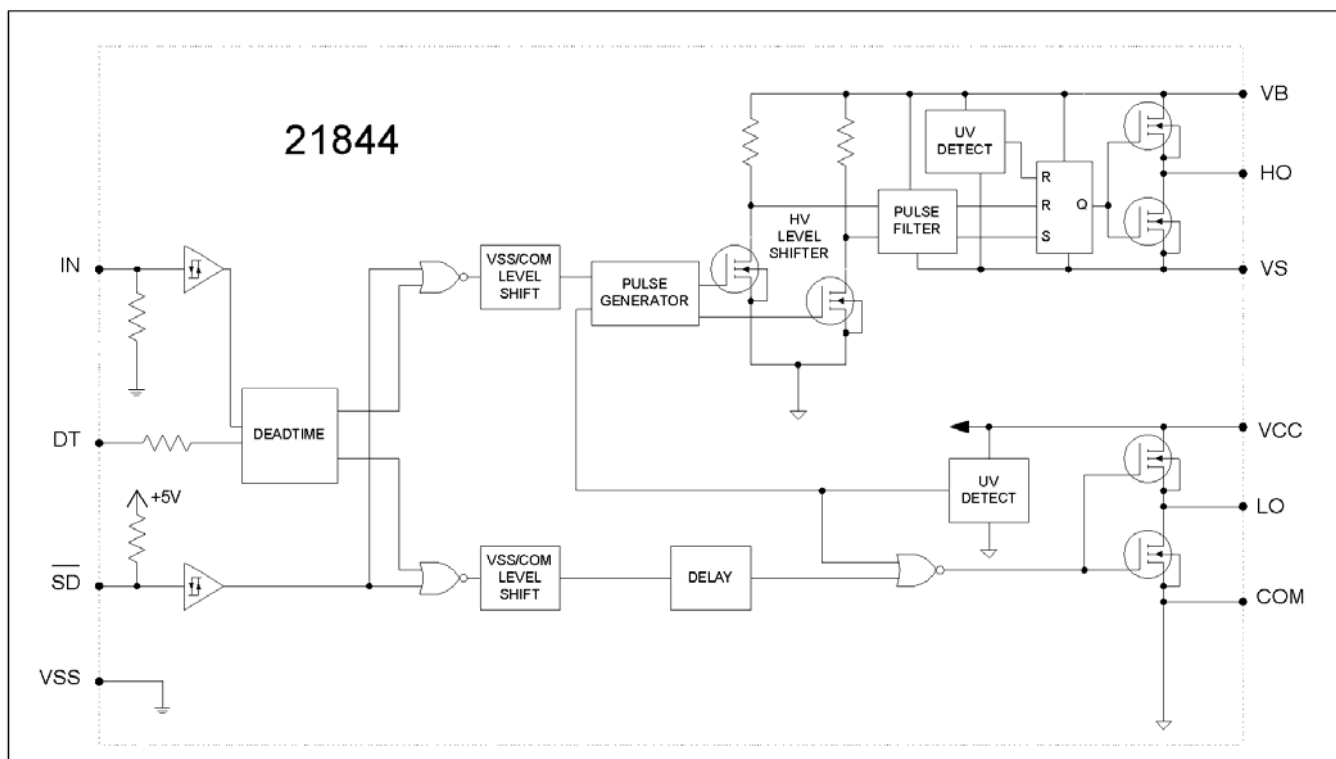

Figure 41: Internal block diagram for IR21844 showing level shifter and the two floating outputs to drive both output devices

Also not shown in the above Figure 41 (but shown in Figure 40) are the output FETS. If the maximum output is approximately 100V, then an output FET such as the IRFBC40LC could be used as the output device. The input capacity of the BC40LC FET is 15pF in a source follower arrangement, avoiding the 1100pF input capacitance.

10. Conclusions:

A successful demonstration of a non-linear acoustic concealed weapons detection system is reported from proof-of-concept tests at 6 inches scaled up to 15 feet. A near range system for use in corrections institutes is also demonstrated. A clear extension of the work for a practical implementation both for near range and long range has been suggested. Additional results obtained during this project are included in appendixes. Appendix A covers some of the results obtained outdoors and tests under clothing. Appendix B includes supporting simulation results for predicting non-linear beam patterns and sound pressure levels for various transducer sizes at different propagation distances. Appendix C is a support letter from the Northeastern Technology and Product Assessment Committee (NTPAC).

11. Bibliography

1. Los Angeles Police Department,
URL: <http://www.lapdonline.org/portal/generic.php?page=/search.ph>
2. Sarah V. Hart, *Making Prisons Safer Through Technology*, Corrections Today, 65 2003.
3. *Detecting Concealed Weapons: Technology Research at the National Institute of Justice*, Corrections Today, American Correctional Association, July 2001
4. Spawar systems center, *Correctional officer duress system – Selection Guide*, Document number 202947
5. N.G. Paulter. *Guide to the Technologies of Concealed Weapon and Contraband Imaging and Detection*. NIJ Guide 602-00. National Institute of Justice Law Enforcement and Corrections Standards and Testing Program. February 2001
6. New Scientist print edition, *Handheld terahertz wand to unmask terrorists*. July 2004
URL: <http://www.newscientist.com/article.ns?id=dn6118>.
7. *Presidential Report on Radiation Protection Advice: Screening of Humans for Security Purposes Using Ionizing Radiation Scanning Systems*. A Report Prepared by the National Council on Radiation Protection and Measurements
8. L. Kinsler and A.Frey, *Fundamentals of Acoustics*. New York: John Wiley and Sons, 1962.
9. N.G. Paulter. *Guide to the Technologies of Concealed Weapon and Contraband Imaging and Detection*. NIJ Guide 602-00. National Institute of Justice Law Enforcement and Corrections Standards and Testing Program. February 2001
10. Sarah V. Hart, *Making Prisons Safer Through Technology*, Corrections Today, 65 2003.
11. *Detecting Concealed Weapons: Technology Research at the National Institute of Justice*, Corrections Today, American Correctional Association, July 2001
12. Spawar systems center, *Correctional officer duress system – Selection Guide*, Document number 202947
13. P.J. Westervelt, *Parametric Acoustic Array*, J. Acoust. Soc. Am. 35, 535-537, 1963

14. M.F. Hamilton and D.T. Blackstock, *Nonlinear Acoustics*, Academic Press, 1998
15. Fatemi, L.E. Wold, A. Alizad, and J.F. Greenleaf. *Vibro-Acoustic Tissue Mammography*. IEEE Trans. Med. Imaging. 21,:1-8 (2002)
16. R. S. Lima ; S.E. Kruger; G. Lamouche ; B. R. Marple, *Elastic Modulus Measurements via Laser-Ultrasonic and Knoop Indentation Techniques in Thermally Sprayed Coatings*, Journal of Thermal Spray Technology, 14, 52-60 (2005)
17. J.J. Croft and J.O. Norris, *Theory, History, and Advancement of Parametric Loudspeaker* American Technologies Corporation White Paper –
URL: <http://www.atcsd.com/pdf/HSSWHTPAPERRevE.pdf>
18. F.J. Pompei, *The Use of Airborne Ultrasonics for Generating Audible Sound Beams*, J. Audio Engineering Society 47(9), Sep 1999
19. Audio Beam Product Sheet
URL: <http://www.sennheiserusa.com/newsite/pdfs/AudioBeam.pdf>
20. M. B. Bennett and D. T. Blackstock, *Parametric Array in Air*, J of Acous. Soc. Of Am, 57, 562-568, 1975.
21. D.T. Blackstock, *Audio applications of the parametric array* Journal of Acoustical Society of America 102, 3106(A), Conference Abstract, May 1997
22. Y.-S. Lee, M. F. Hamilton, *Time-domain modeling of pulsed finite-amplitude sound beams*, J. Acoust. Soc. Am. 97, pp. 906-917, 1995.
23. Y. Lee, *Numerical Solution of the KZK Equation for Pulsed Finite Amplitude Sound Beams in Thermoviscous Fluids*. Ph.D. Dissertation. The University of Texas at Austin, 1993.
24. The Ultrason Group, *Gas matrix Piezoelectric transducer*:
URL: <http://www.ultrasongroup.com/pdfs/GMP.pdf>
25. J. Heyman, A. Achanta, M. Hinders, K. Rudd and P. Costianes, *Nonlinear acoustic concealed weapons detection (CWD)*, SPIE Defense & Security Symposium, Conference 5807 Automatic Target Recognition XV, Orlando, FL, 29 March 2005.
26. A.Achanta, M.J.McKenna, J.S.Heyman et al, *Non-Linear Acoustic Concealed Weapons Detection*, Materials Evaluation, Vol 63, no. 12.
27. Y.-S. Lee, M. F. Hamilton, *Time-domain modeling of pulsed finite-amplitude sound beams*, J. Acoust. Soc. Am. 97, pp. 906-917, 1995.

Appendix A: Additional Results

Acoustic Propagation up to 15 feet using Unfocused Transducers

Some of the initial tests were done with COTS parametric speakers. Experiments with unfocused transducers included the use of HSS and Audio Spotlight. Some of the key successes demonstrated with unfocused transducers are as follows.

A1. Audio generation and penetration though thick clothing at 15 feet

Even though the transducers are unfocused, while waiting for delivery of focused transducers, we were able to study the propagation of acoustic beams through various types of clothing. In the following figure A1, a 1 foot unfocused transducer was driven at 51 kHz with an amplitude modulated (AM) signal in the parametric beam mixing mode set-up to generate a low frequency audio signal at 5 kHz. This 5 kHz signal was the probing beam generated from beam mixing.

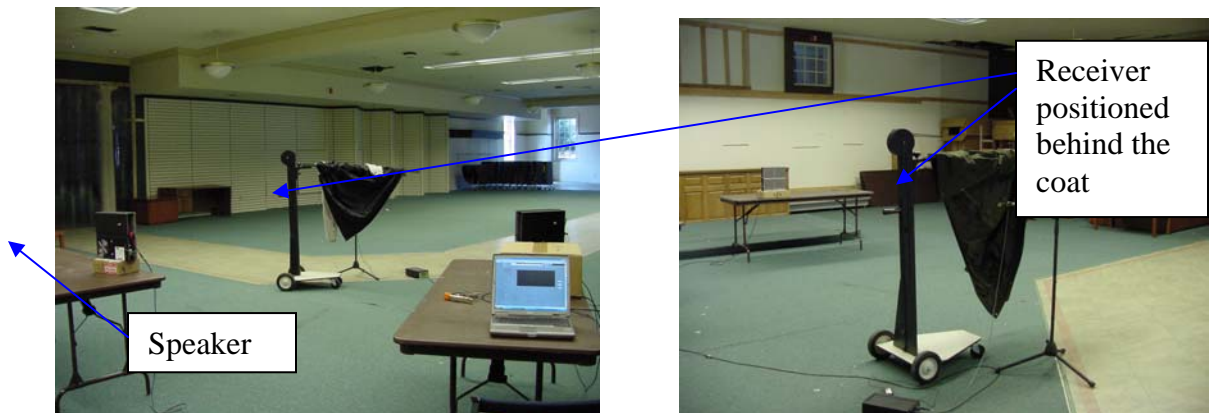

Figure A1: Experimental set-up for show that non-linear acoustic approach has the capability to see through thick clothing

A microphone was placed at 15 feet in front of the transducer with and without the winter coat in front of it. Figure A2 shows the spectral amplitude data recorded by the microphone. The goal of this test was to demonstrate that NAC approach can detect weapons through clothing by generating a low frequency acoustic beam at the target. As can be seen from this figure, when a thick coat was placed in front of a microphone, the ultrasound spectrum (right-lower figure) drops drastically, but the audio amplitude drops only a little (left-lower figure)

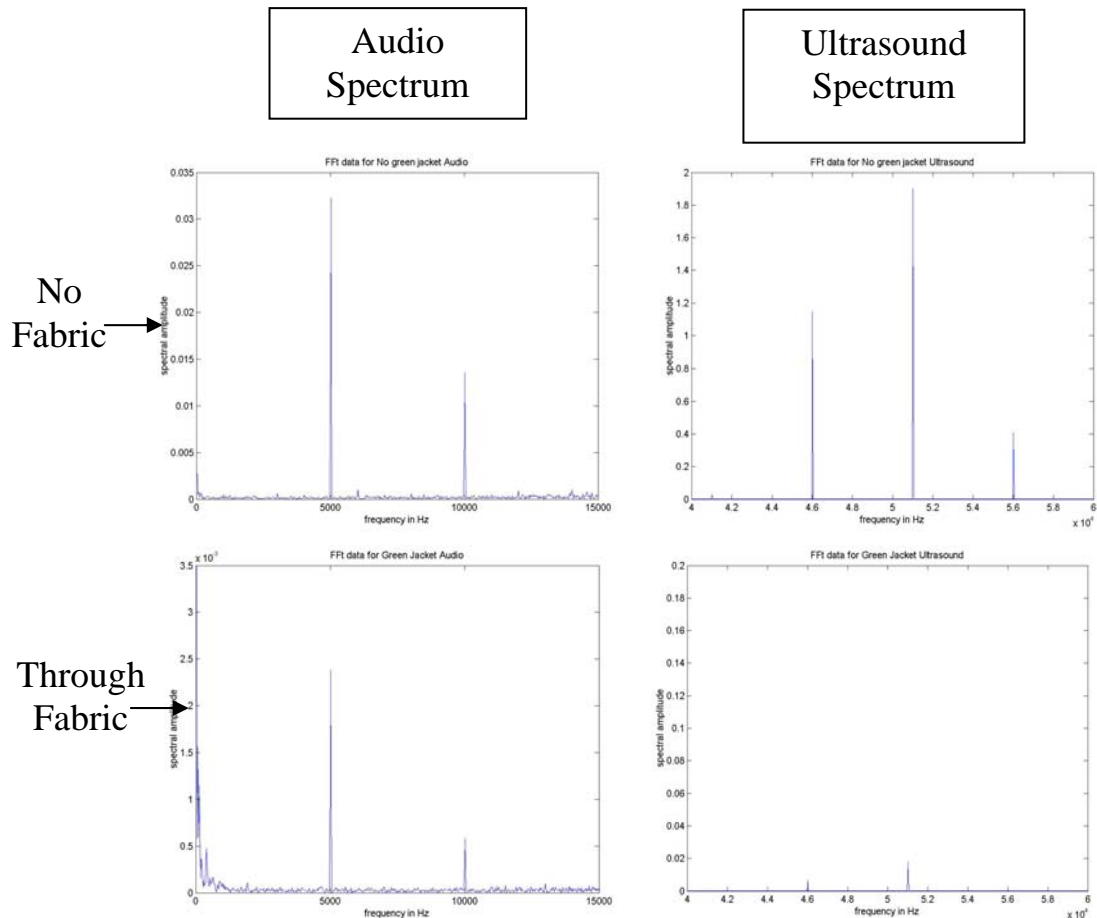

Figure A2: Audio propagation through thick clothing. Due to presence of thick fabric, even though the ultrasound drops off drastically, the audio beam attenuates by a small amount and a strong signal passing through the thick fabric was recorded by the receiver. This audio signal is used as the probing beam to detect the weapon signature. The audio x axis is from x to y Hz while the y axis is normalized intensity. The ultrasonic x axis goes from xHz to Y Hz.

A2. Acoustically resonating objects from 15 feet through non-linear approach

Following is a description of a test conducted that shows that we can excite a target weapon at its resonance using NAC approach. The object used for testing was a steel tube that resonated at ~2.1kHz. The ultrasonic source was directed at a flat absorbing background (no weapon) placed behind the target. A microphone was placed close to this surface in order to listen to the response of the target. The input signal to the transducer was an amplitude modulated signal, with a carrier frequency of 48 kHz. The AM frequency was set to vary from 1 kHz to 3.4 kHz in steps of 20Hz creating 120 increments. At very high sound pressure level, due to the non-linear nature of the air, de-modulation of the AM signal occurs as the signal propagates away from the transducer. This de-modulation produces the audio frequency in air which is same as the AM frequency. Hence

to control the audio frequency incident on the target, we simply changed the AM frequency.

In the figure A3 (a), pink curve is spectral amplitude plot from the flat background with no steel tube placed on it. The blue curve is the same plot when this tube was attached to the flat absorbing background. The microphone and transducer position was unchanged during both tests. A strong response from the steel rod was expected at 2.1 kHz.

The quality factor or Q of the tube weapon would have reduced when it was mounted on the flat background. The transducer (HSS) characteristics due to its bandwidth were also expected to play a role when the AM frequency was changed. To get rid of these effects, the no weapon data was subtracted from the weapon data and the result is shown in figure A3(b). The curve in figure A3 (b) peaks at 2.1kHz which is only due to the vibration of the target. Here, we also notice the second peak at the end of the plot characteristic of the mode we are exciting.

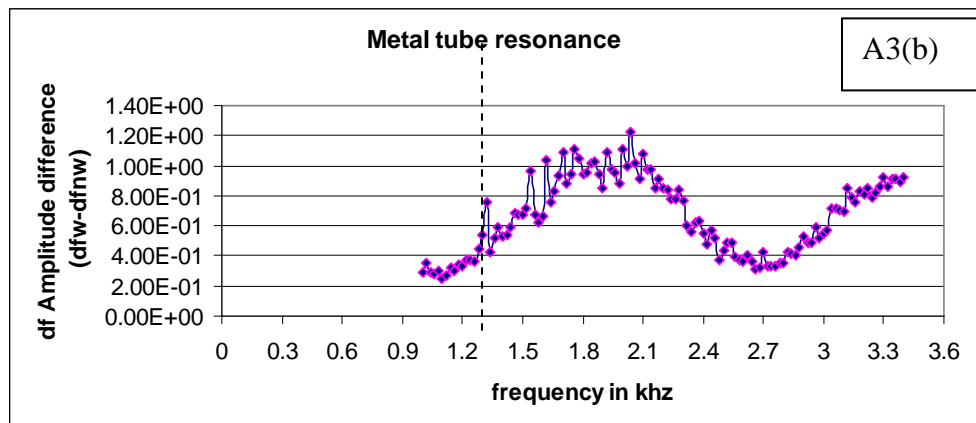
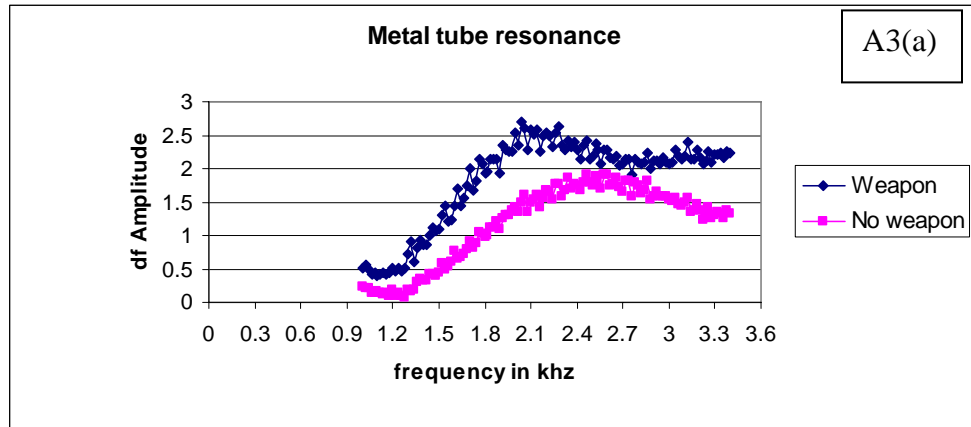

Figure A3: A3(a) is a plot showing the response of a flat absorbing background in pink and a metal tube in blue to changing frequency of the probing beam. A3(b) is the pink curve subtracted from the blue curve to show the effect of presence of weapon. Since the tube resonance falls within this frequency range we see the bottom curve peak at 2.1 kHz

By sweeping the probing beam frequency over a wide range, we can “sound out” a target and classify it as a weapon or a non-weapon. This was an important set of data recorded during the course of our experiments which helped us define the short-duration-varying frequency signals or chirps for real-time weapons detection.

A2. Outdoor Tests:

A3.

In order to extend our tests to a more practical situation in the presence of a noisy environment, we focused some of our efforts in conducting NAC tests outdoors as shown in figure A4. The non-linear acoustic approach allows us to set-up probing frequencies with precise control. The narrow bandwidth of such a signal could easily be distinguished from noise as shown in figure A6.



Figure A4: Luna experimental set-up moved from laboratory to outdoors to study the signal-to-noise ratio and effect of ambient noise that may interfere with weapons detection data in a real test situation.

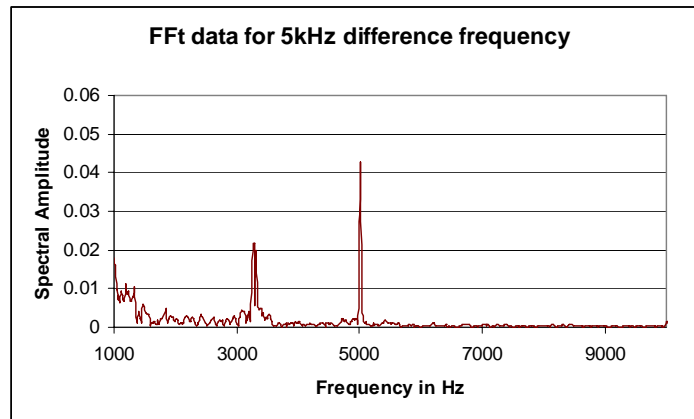

Figure A5: Plot showing the frequency spectrum of a signal recorded off of targets from 20 feet in an open outside environment. The 5 kHz probing frequency could easily be distinguished from the 3.2 kHz noise from bird

Although current experimental set-up involves the set-up of many hardware components, we will integrate the entire system into a handheld device in the next phase of our project.

Appendix B: Simulations

B1. Data Analysis and Projection for Targets beyond 15 feet

One of our goals in this last phase of the project was conducting nonlinear computer simulations to assist in the hardware design for the future longer range acoustic concealed weapons detector. Over 80 combinations of transducer sizes and focal distances have been simulated to extrapolate current measurements from 5 meters to 15 meters. The existing hardware configuration consists of a 0.61m (2ft) diameter transducer with a focal distance close to 5 meters. According to simulations previously completed, the full-width half-max beam width of the 50 kHz component is about 8cm at 5 meters. Simulations have been used to test different transducer sizes of different curvatures to find the correct combination to extend this range to 15 meters. Accomplishing this experimentally would be very time consuming and expensive because testing each configuration would require building a separate device.

B2. Simulation Descriptions and Results

Five transducer diameters were tested: 0.6m (1.97ft), 0.9m (2.95ft), 1.2m (3.94ft), and 1.5m (4.92ft). Many geometrical curvatures were tested for each of the different sized transducers. For each simulation, the transducer emits a short dual-tone burst at 50 kHz and 55 kHz. The focal distance and the corresponding beam width were recorded for these two frequencies and the 5 kHz nonlinear generated difference frequency. A sample of these results is shown in Tables B1 – B4 for the four different sized transducers with geometrical focuses ranging from 14 to 17 meters.

Performing nonlinear acoustic simulations for large transducers out to 15 meters (requested by the TPOC) requires substantial computer resources because the entire volume is discretized in the EFIT technique. The spatial resolution of the simulations had to be reduced in order to squeeze the simulation space onto the confined memory restraints of a standard desktop PC. This reduction in spatial resolution introduces a small uncertainty into the results shown in Tables B1-B4. The uncertainty in the focal distances is $\pm 10\text{cm}$ and in the focal width is $\pm 1\text{ cm}$.

Table B1: 0.6 Meter Diameter Transducer

Geometrical Focus	Actual Focus Distance and Beam Widths					
	55kHz focus		50kHz focus		5kHz focus	
	distance	width	distance	width	distance	width
14.0m	9.32m	12.7cm	8.94m	13.5cm	2.36m	35.5cm
14.5m	9.54m	13.0cm	8.94m	13.8cm	2.36m	35.7cm
15.0m	9.74m	13.3cm	9.14m	14.1cm	2.36m	35.9cm
15.5m	9.74m	13.6cm	9.34m	14.4cm	2.36m	36.1cm
16.0m	9.94m	13.8cm	9.54m	14.7cm	2.36m	36.3cm
16.5m	10.14m	14.1cm	9.74m	15.0cm	2.36m	36.5cm
17.0m	10.34m	14.5cm	9.94m	15.2cm	2.38m	36.6cm

Table B2: 0.9 Meter Diameter Transducer

Geometrical Focus	Actual Focus Distance and Beam Widths					
	55kHz focus		50kHz focus		5kHz focus	
	distance	width	distance	width	distance	width
14.0m	11.74m	10.2cm	11.56m	11.2cm	4.12m	41.8cm
14.5m	12.32m	10.6cm	11.74m	11.4cm	4.16m	42.3cm
15.0m	12.34m	10.8cm	12.32m	11.8cm	4.30m	42.7cm
15.5m	12.92m	11.1cm	12.34m	12.1cm	4.30m	43.0cm
16.0m	13.32m	11.5cm	12.54m	12.4cm	4.32m	43.2cm
16.5m	13.54m	11.8cm	13.14m	12.7cm	4.32m	43.5cm
17.0m	13.82m	12.1cm	13.52m	13.0cm	4.34m	43.9cm

Table B3: 1.2 Meter Diameter Transducer

Geometrical Focus	Actual Focus Distance and Beam Widths					
	55kHz focus		50kHz focus		5kHz focus	
	distance	width	distance	width	distance	width
14.0m	12.94m	8.2cm	12.74m	8.9cm	5.76m	45.0cm
14.5m	13.34m	8.5cm	13.14m	9.2cm	5.76m	45.4cm
15.0m	13.72m	8.8cm	13.92m	9.6cm	5.96m	46.0cm
15.5m	14.32m	9.0cm	14.12m	9.8cm	5.96m	46.5cm
16.0m	14.74m	9.3cm	14.52m	10.1cm	6.28m	47.3cm
16.5m	15.14m	9.6cm	14.54m	10.4cm	6.16m	47.7cm
17.0m	15.52m	9.8cm	15.14m	10.7cm	6.16m	48.2cm

Table B4: 1.5 Meter Diameter Transducer

Geometrical Focus	Actual Focus Distance and Beam Widths					
	55kHz		50kHz		5kHz	
	distance	width	distance	width	distance	width
14.0m	13.54m	6.8cm	13.52m	7.4cm	7.52m	46.1cm
14.5m	13.94m	7.0cm	13.92m	7.8cm	7.54m	46.7cm
15.0m	14.42m	7.2cm	14.34m	7.9cm	7.70m	47.5cm
15.5m	14.62m	7.6cm	14.56m	8.2cm	7.72m	48.1cm
16.0m	15.12m	7.8cm	15.02m	8.4cm	7.94m	48.8cm

Determining the best transducer size and curvature to focus the sound beam at 15 meters requires knowing the actual frequencies that will be used for detecting concealed weapons. Since this has yet to be determined, the 50 kHz frequency component is used here to compare the beam widths at 15 meters. The curvatures and corresponding beam widths that best focus the 50 kHz component of the beam for the different transducer

sizes are shown in Table B5. The acoustic beam profiles for these curvatures are shown in figure B1

Table B5: Approximate curvatures to focus the 50 kHz beam at 15 meters for the four transducer diameters

Transducer Diameter	Geometrical Focus (Curvature)	50 kHz Beam Width at 15 Meters
0.6 meter (~2ft)	25m	21cm
0.9 meter (~3ft)	19.5m	15cm
1.2 meter (~4ft)	17m	11cm
1.5 meter (~5ft)	16m	8cm

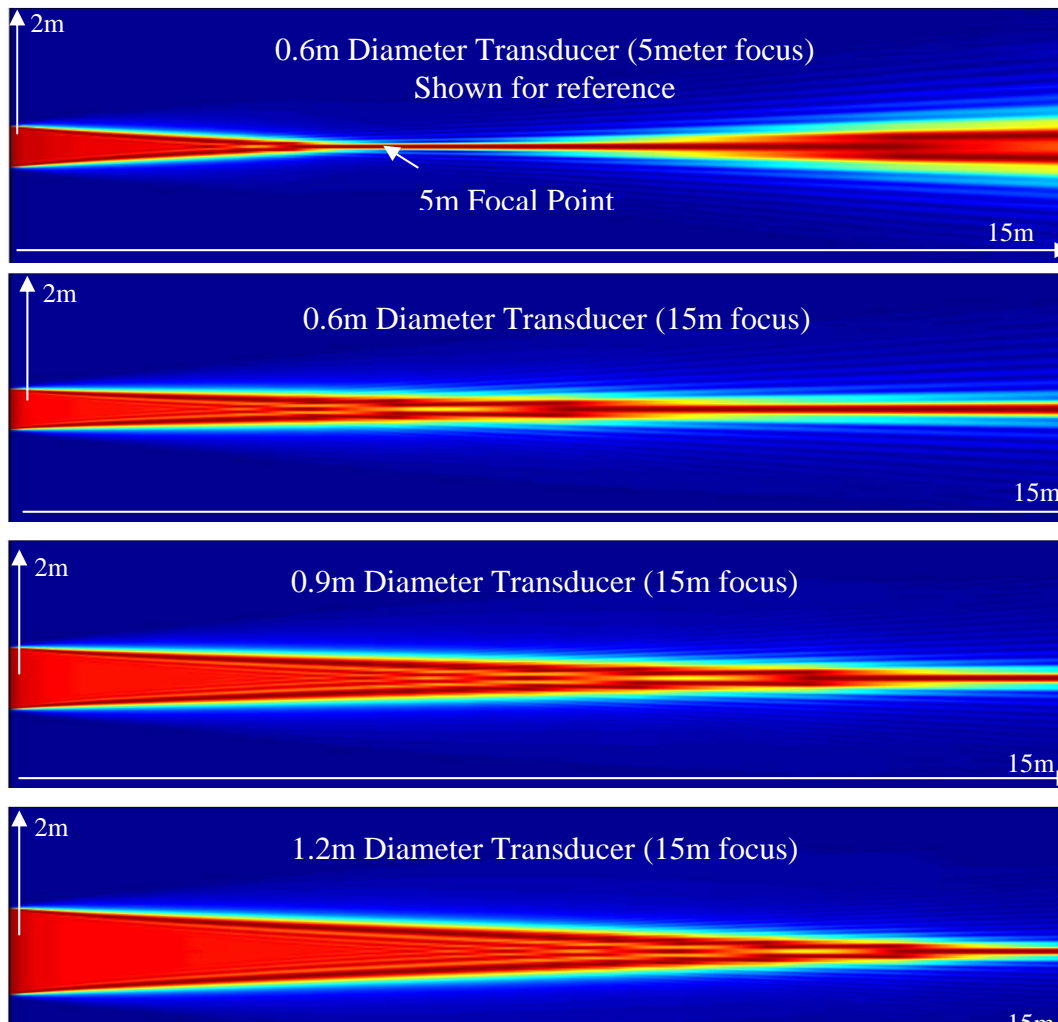

Figure B1: 50 kHz beam profiles for the four transducer diameters focused at 15 meters. For reference, the top plot shows the 0.6m (2ft) diameter transducer focused at 5 meters. The color represents the amplitude of the sound intensity. Effects of absorption are removed for this plot.

simulation results are from a 5ft diameter parametric array with a geometrical focus of 16 meters.

Note that the absorption of sound is strongly dependent on the frequency of the sound. The absorption is also dependent on factors such as the temperature and the relative humidity of the air. The above simulation assumed the air to be at room temperature with 20% relative humidity.

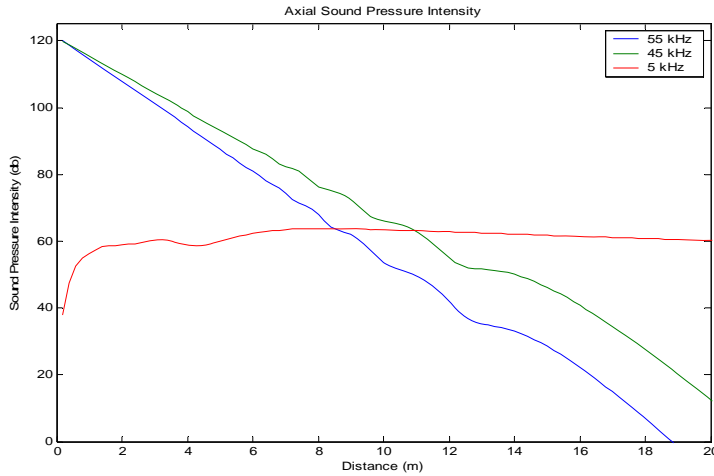

Figure B2: Simulated data showing acoustic absorption out to 20 meters for a case with initial sound pressure intensity of 120dB

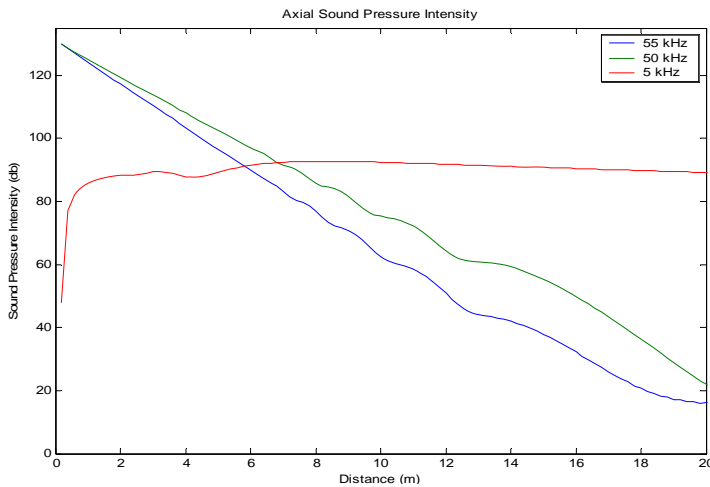

Figure B3: Simulated data showing acoustic absorption out to 20 meters for a case with initial sound pressure intensity of 130dB

These simulations will be used for the future prototype. Many more detail simulations are included in the reports submitted earlier. The author may be contacted for any specifics (contact information on front page)

Appendix C: Letter of Support



October 24, 2005

Dr. Joseph Heyman, Chief Scientist
Luna Innovations
130 Research Drive
Hampton, VA 23666

Dear Dr. Heyman:

On June 30, 2005, the Northeast Technology and Product Assessment Committee (NTPAC) met in Sturbridge, MA to explore new technology appropriate for the corrections community. Present at that meeting were high level representatives from the Northeast states. NTPAC has representatives from 13 states and the District of Columbia.

The technology that you presented at the meeting was a work-in-progress from your company Luna Innovations on an ultrasonic/acoustic approach to finding concealed weapons on a person.

Your briefing stimulated discussions among the NTPAC members encouraged me as Chairman of NTPAC to prepare this letter in support of the development of a system such as the NAC for the corrections community. Based on the data we saw, this may be an ideal capability enhancing security in corrections facilities. For example, the Bureau of Justice reports 14,165 attacks on prison staff by inmates, with 14 deaths and a 32% increase in five years. One problem that was discussed by NTPAC was the concern over improvised weapons made from plastic or metal and hidden under clothing. The ability of an inmate to hide a cell phone under clothing was also raised.

Since a correction facility mandates uniform clothing and can perform inspections at close range, the development of a wand-like or handheld NAC device could become a significant tool for contraband inspections.

The impact of such a development for corrections should be a priority. There are two main reasons for the timeliness of this development. First is the need in prison for a non-contacting inspection for metals and plastics and second is that the technology is at a stage of maturity that it can be reduced to practical use quickly – it is a low hanging fruit of great value.

Sincerely,

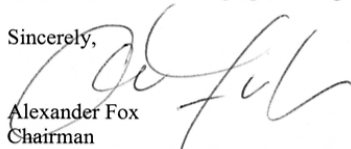

Alexander Fox
Chairman
Northeast Technology & Product Assessment Committee

Figure C1: Support letter from the Northeast Technology & Product Assessment Committee