



AISI S240-15



**American
Iron and Steel
Institute**

AISI STANDARD

North American Standard for Cold-Formed Steel Structural Framing

2015 Edition



AISI S240-15



AISI STANDARD

North American Standard for Cold-Formed Steel Structural Framing

2015 Edition

DISCLAIMER

The material contained herein has been developed by the American Iron and Steel Institute (AISI) Committee on Framing Standards. The Committee has made a diligent effort to present accurate, reliable, and useful information on cold-formed steel framing design and installation. The Committee acknowledges and is grateful for the contributions of the numerous researchers, engineers, and others who have contributed to the body of knowledge on the subject. Specific references are included in the *Commentary*.

With anticipated improvements in understanding of the behavior of cold-formed steel framing and the continuing development of new technology, this material will become dated. It is anticipated that AISI will publish updates of this material as new information becomes available, but this cannot be guaranteed.

The materials set forth herein are for general purposes only. They are not a substitute for competent professional advice. Application of this information to a specific project should be reviewed by a design professional. Indeed, in many jurisdictions, such review is required by law. Anyone making use of the information set forth herein does so at their own risk and assumes any and all liability arising therefrom.

1st Printing – December 2015

Copyright American Iron and Steel Institute 2015



This first edition of AISI S240, *North American Standard for Cold-Formed Steel Structural Framing*, is dedicated to John P. Matsen, P.E. John was a widely respected structural engineer for over three decades and founder and principal of Matsen Ford Design Associates. Throughout his career, he helped pioneer and expand the use of cold-formed steel framing in structural and nonstructural applications.

From the inception of the AISI Committee on Framing Standards in 1998, John was an active member. He served as chair of its High Wind Subcommittee from 1998 to 2001, enabling the *AISI Standard for Cold-Formed Steel Framing—Prescriptive Method for One- and Two-Family Dwellings* to be expanded in scope to address high wind areas. He actively engaged in the Committee's numerous subcommittees and task groups, and was always an effective contributor.

John was also an active member of the Cold-Formed Steel Engineers Institute, helping to author and review technical notes, providing webinars, serving as a member of the Executive Committee, and leading as Chair of the Institute from 2009 to 2010. John was always willing to offer his expertise to help advance the profession.

The cold-formed steel industry gratefully acknowledges his many enduring contributions.

This Page is Intentionally Left Blank.

PREFACE

The American Iron and Steel Institute (AISI) Committee on Framing Standards has developed AISI S240, *North American Standard for Cold-Formed Steel Structural Framing*, to address requirements for construction with cold-formed steel structural framing that are common to prescriptive and engineered design. This Standard is intended for adoption and use in the United States, Canada and Mexico.

This Standard integrated the following AISI Standards into one document:

- AISI S200-12, *North American Standard for Cold-Formed Steel Framing-General Provisions*
- AISI S210-07 (2012), *North American Standard for Cold-Formed Steel Framing-Floor and Roof System Design* (Reaffirmed 2012)
- AISI S211-07(2012), *North American Standard for Cold-Formed Steel Framing-Wall Stud Design* (Reaffirmed 2012)
- AISI S212-07(2012), *North American Standard for Cold-Formed Steel Framing-Header Design* (Reaffirmed 2012)
- AISI S213-07w/S1-09(2012), *North American Standard for Cold-Formed Steel Framing-Lateral Design with Supplement 1* (Reaffirmed 2012)
- AISI S214-12, *North American Standard for Cold-Formed Steel Framing-Truss Design*

Consequently, AISI S240 will supersede all previous editions of the above-mentioned individual AISI Standards.

In 2015, AISI S400, *North American Standard for Seismic Design of Cold-Formed Steel Structural Systems*, was developed. Modifications were made to align the provisions of AISI S240 with AISI S400, as follows:

- The applicability of AISI S240 for seismic design was limited to applications when specific seismic detailing is not required.
- Definitions no longer needed in AISI S240 were removed and remaining definitions were revised, if needed, for consistency with AISI S400.
- Seismic-specific tables for *nominal shear strength [resistance]* were deleted.
- Seismic-specific safety factors and resistance factors were deleted.
- Other seismic-specific requirements were removed, as appropriate, and remaining requirements were generalized for applicability to wind, seismic or other lateral loads.

Also in this edition, a new Chapter F on testing was added to allow reference to applicable AISI 900-series test Standards. Methods for *truss* tests, formerly in Section E7, were moved to Appendix 2.

While not necessary, use of the more stringent requirements for *structural members* that are in this Standard for *nonstructural members* should be permitted, since these should demonstrate equivalent performance for the intended use to those specified in AISI S220, *North American Standard for Cold-Formed Steel Framing-Nonstructural Members*.

The Committee acknowledges and is grateful for the contributions of the numerous engineers, researchers, producers and others who have contributed to the body of knowledge on the subjects. The Committee wishes to also express its appreciation for the support of the Canadian Sheet Steel Building Institute.

This Page is Intentionally Left Blank.

Section Reference Between AISI S240 and AISI S200, S210, S211, S212, S213, and S214

AISI S240 Section	Title	Source Standard	Section
A.	GENERAL	S200 to S214	A
A1	Scope	S200 to S214	A1
A1.1		S200	A1
A1.2		S200 to S214	A1
A1.2(a)		S210	A1
A1.2(b)		S211 and S212	A1
A1.2(c)		S213	A1
A1.2(d)		S214	A1
A1.3		new	
A1.4		S210 to S212	A1
A1.5		S200 to S214	A1
A1.6		S200 to S214	A1
A1.7		S200 to S214	A1
A2	Definitions	S200 to S214	A2
A2.1	Terms	S200	A2
A3	Material	S200	A3
A4	Corrosion Protection	S200	A4
A4.1		S200	A4.1
A4.2		S200	A4.2
A4.3		S200	A4.3
A4.4		S200	A4.4
A4.5		S200	A4.5
A4.6		S200	A4.6
A5	Products	S200	A5
A5.1	Base Steel Thickness	S200	A5.1
A5.2	Minimum Flange Width	S200	A5.2
A5.3	Product Designator	S200	A5.3
A5.4	Manufacturing Tolerances	S200	A5.4
A5.5	Product Identification	S200	A5.5
A6	Referenced Documents	S200 to S214	varies
B.	DESIGN	S210 to S212	B
B1	General	new (editorial)	n/a
B1.1	Loads and Load Combinations	S210 to S214	varies
B1.1.1	Live Load Reduction on Wall Studs	new	n/a
B1.1.2	Wind Loading Considerations for Wall Studs in U.S. and Mexico	S211	A3.1
B1.2	Design Basis	S210 and S211	B

Section Reference Between AISI S240 and AISI S200, S210, S211, S212, S213, and S214

AISI S240 Section	Title	Source Standard	Section
		S213 and S214	B1
B1.2.1	Floor Joists, Ceiling Joists and Roof Rafters	S210	B1
B1.2.2	Wall Studs	S211	B1
B1.2.3	In-Line Framing	S200	C1
B1.2.4	Sheathing Span Capacity	S200	C2
B1.2.4.1		S200	C2.3.2
B1.2.4.2		S200	C2.4.2
B1.2.4.3		S200	C2.5.2
B1.2.5	Load Path	S213	C1
B1.2.6	Principles of Mechanics	S213	B2
B1.3	Built-Up Section Design	S210	B1.5
		S211	B1.7
B1.3.1		S211	B1.7
B1.3.2		S211	B1.7
B1.4	Properties of Sections	S210 and S211	B1.1
B1.5	Connection Design	S211	B2.1
B1.5.1	Screw Connections	S200	D1
B1.5.1.1	Steel-to-Steel Screws	S200	D1.1
B1.5.1.2	Sheathing Screws	S200	D1.2
B1.5.1.3	Spacing and Edge Distance	S200	D1.5
B1.5.1.4	Gypsum Board	S200	D1.6
B1.5.2	Welded Connections	S200	D2
B1.5.3	Bolts	S200	D3.1
B1.5.4	Power-Actuated Fasteners	new	
B1.5.5	Other Connectors	S200	D3.2
B1.5.6	Connection to Other Materials	S200	D3.3
B2	Floor and Ceiling Framing	new (editorial)	n/a
B2.1	Scope	new (editorial)	n/a
B2.2	Floor Joist Design	new (editorial)	n/a
B2.2.1	Bending	new (editorial)	n/a
B2.2.1.1	Lateral-Torsional Buckling	S210	B1.2.1
B2.2.1.2	Distortional Buckling	new	n/a
B2.2.2	Shear	S210	B1.2.2
B2.2.3	Web Crippling	S210	B1.2.3
B2.2.4	Bending and Shear	S210	B1.2.4
B2.2.5	Bending and Web Crippling	S210	B1.2.5
B2.3	Ceiling Joist Design	new (editorial)	n/a
B2.3.1	Tension	S210	B1.3.1
B2.3.2	Compression	new (editorial)	n/a
B2.3.2.1	Yielding, Flexural, Flexural-Torsional and Torsional Buckling	S210	B1.3.1
B2.3.2.2	Distortional Buckling	new	n/a
B2.3.3	Bending	new (editorial)	n/a

Section Reference Between AISI S240 and AISI S200, S210, S211, S212, S213, and S214

AISI S240 Section	Title	Source Standard	Section
B2.3.3.1	Lateral-Torsional Buckling	S210	B1.3.2
B2.3.3.2	Distortional Buckling	new	n/a
B2.3.4	Shear	S210	B1.3.3
B2.3.5	Web Crippling	S210	B1.3.4
B2.3.6	Axial Load and Bending	S210	B1.3.5
B2.3.7	Bending and Shear	S210	B1.3.6
B2.3.8	Bending and Web Crippling	S210	B1.3.7
B2.4	Floor Truss Design	S210	B2
B2.5	Bearing Stiffeners	S210	B3.1
B2.5.1	Clip Angle Bearing Stiffeners	S210	B3.1.1
B2.6	Bracing Design	S210	B4
B2.7	Floor Diaphragm Design	S210	B5
B3	Wall Framing	new (editorial)	n/a
B3.1	Scope	new (editorial)	n/a
B3.2	Wall Stud Design	new (editorial)	n/a
B3.2.1	Axial Strength [Resistance] Yielding, Flexural, Flexural-Torsional and Torsional	new (editorial)	n/a
B3.2.1.1	Buckling	S211	B1.2
B3.2.1.2	Distortional Buckling	new	n/a
B3.2.2	Bending	new (editorial)	n/a
B3.2.2.1	Lateral-Torsional Buckling	S211	B1.3
B3.2.2.2	Distortional Buckling	MS09-3A	n/a
B3.2.3	Shear	S211	B1.4
B3.2.4	Axial Load and Bending	S211	B1.5
B3.2.5	Web Crippling	S211	B1.6
B3.2.5.1	Stud-to-Track Connection for C-Section Studs	S211	B2.2
B3.2.5.2	Deflection Track Connection for C-Section Studs	S211	B2.3
B3.3	Header Design	S212	B
B3.3.1	Back-to-Back Headers	S212	B1
B3.3.2	Box Headers	S212	B2
B3.3.3	Double L-Headers	S212	B3
B3.3.4	Single L-Headers	S212	B4
B3.3.5	Inverted L-Header Assemblies	S212	B5
B3.4	Bracing	S211	B3
B3.4.1	Intermediate Brace Design	S211	B3.1
B3.5	Serviceability	S211	B4
B4	Roof Framing	new (editorial)	n/a
B4.1	Scope	new (editorial)	n/a
B4.2	Roof Rafter Design	new (editorial)	n/a
B4.2.1	Tension	S210	B1.4.1
B4.2.2	Compression	new (editorial)	n/a
B4.2.2.1	Yielding, Flexural, Flexural-Torsional and Torsional	S210	B1.4.1

Section Reference Between AISI S240 and AISI S200, S210, S211, S212, S213, and S214

AISI S240 Section	Title	Source Standard	Section
	Buckling		
B4.2.2.2	Distortional Buckling	new	n/a
B4.2.3	Bending	new (editorial)	n/a
B4.2.3.1	Lateral-Torsional Buckling	S210	B1.4.2
B4.2.3.2	Distortional Buckling	new	n/a
B4.2.4	Shear	S210	B1.4.3
B4.2.5	Web Crippling	S210	B1.4.4
B4.2.6	Axial Load and Bending	S210	B1.4.5
B4.2.7	Bending and Shear	S210	B1.4.6
B4.2.8	Bending and Web Crippling	S210	B1.4.7
B4.3	Roof Truss Design	S210	B2
B4.4	Bearing Stiffeners	S210	B3.1
B4.5	Bracing Design	S210	B4
B4.6	Roof Diaphragm Design	S210	B5
B5	Lateral Force-Resisting Systems	new (editorial)	n/a
B5.1	Scope	new (editorial)	n/a
B5.2	Shear Wall Design	S213	C
B5.2.1	General	S213	C1
B5.2.1.1	Type I Shear Walls	S213	C2
B5.2.1.2	Type II Shear Walls	S213	C3
B5.2.2	Nominal Strength [Resistance]		
B5.2.2.1	Type I Shear Walls	S213	C2
B5.2.2.2	Type II Shear Walls	S213	C3
B5.2.3	Available Strength [Factored Resistance]	S213	C2
B5.2.4	Collectors and Anchorage	S213	C3.3
B5.2.5	Design Deflection	S213	C2.1.1
B5.3	Strap Braced Wall Design	S213	C4
B5.4	Diaphragm Design	S213	D
B5.4.1	General	S213	D1
B5.4.2	Nominal Strength	S213	D2
B5.4.3	Available Strength	S213	D2
B5.4.4	Design Deflection	S213	D2
B5.4.5	Beam Diaphragm Tests for Non-Steel Sheathed Assemblies	S213	D4
C.	INSTALLATION	S200 to S212	C
C1	General	S210 to S212	C
C2	Member Condition	S200	B2
C2.1	Web Holes	S200	B2.1
C2.2	Cutting and Patching	S200	B2.2.1
C2.3	Splicing	S200	B2.2.2

Section Reference Between AISI S240 and AISI S200, S210, S211, S212, S213, and S214

AISI S240 Section	Title	Source Standard	Section
C3	Structural Framing	S200	C2
C3.1	Foundation	S200	C2.1
C3.2	Ground Contact	S200	C2.2
C3.3	Floors	S200	C2.3
C3.3.1	Plumbness and Levelness	S200	C2.3.1
C3.3.2	Alignment	S200	C2.3.2, C2.3.3
C3.3.4	Bearing Width	S200	C2.3.4
C3.3.5	Web Separation	S200	C2.3.5
C3.4	Walls		
C3.4.1	Straightness, Plumbness and Levelness	S200	C2.4.1
C3.4.2	Alignment	S200	C2.4.2, C2.4.3
C3.4.3	Stud-to-Track Connection	S211	C1
C3.4.4	Back-to-Back and Box Headers	S212	C1
C3.4.5	Double and Single L-Headers	S212	C2
C3.4.6	Inverted L-Header Assemblies	S212	C3
C3.5	Roofs and Ceilings	S200	C2.5
C3.5.1	Plumbness and Levelness	S200	C2.5.1
C3.5.2	Alignment	S200	C2.5.2, C2.5.3
C3.5.3	End Bearing	S200	C2.5.4
C3.6	Lateral Force-Resisting Systems		
C3.6.1	Shear Walls	S213	C2
C3.6.2	Strap Braced Walls	n/a	
C3.6.3	Diaphragms	S213	D2
C4	Connections		
C4.1	Screw Connections	S200	D1
C4.1.1	Steel-to-Steel Screws	S200	D1.1
C4.1.2	Installation	S200	D1.3
C4.1.3	Stripped Screws	S200	D1.4
C4.2	Welded Connections	S200	D2
C5	Miscellaneous	S200	E
C5.1	Utilities	S200	E1
C5.1.1	Holes	S200	E1.1
C5.1.2	Plumbing	S200	E1.2
C5.1.3	Electrical	S200	E1.3
C5.2	Insulation	S200	E2
C5.2.1	Mineral Fiber Insulation	S200	E2.1
C5.2.2	Other Insulation	S200	E2.2
D.	QUALITY CONTROL AND QUALITY ASSURANCE	new	n/a
E.	TRUSSES	S214	A-G

Section Reference Between AISI S240 and AISI S200, S210, S211, S212, S213, and S214

AISI S240 Section	Title	Source Standard	Section
E1	General	S214	A
E1.1	Scope and Limits of Applicability	S214	A1
E2	Truss Responsibilities	S214	B
E3	Loading	S214	C
E4	Truss Design	S214	D
E4.1	Materials	S214	D1
E4.2	Corrosion Protection	S214	D2
E4.3	Analysis	S214	D3
E4.4	Member Design	S214	D4
E4.5	Gusset Plate Design	S214	D5
E4.6	Connection Design	S214	D6
E4.7	Serviceability	S214	D7
E5	Quality Criteria for Steel Trusses	S214	E
E5.1	Manufacturing Quality Criteria	S214	E1
E5.2	Member Identification	S214	E2
E5.3	Assembly	S214	E3
E6	Truss Installation	S214	F
E6.1	Installation Tolerances	S214	F1
E7	Test-Based Design	new (editorial)	
E7.1	Component Structural Performance Load Test	S214	G1
E7.2	Full-Scale Confirmatory Load Test	S214	G2
E7.3	Full-Scale Structural Performance Load Test	S214	G3
F	TESTING	new	n/a
F2	Truss Components and Assemblies	new	n/a
APPENDIX 1	CONTINUOUSLY BRACED DESIGN FOR DISTORTIONAL BUCKLING RESISTANCE	new	n/a
APPENDIX 2	TEST METHODS FOR TRUSS COMPONENTS AND ASSEMBLIES	new	
2.1	Component Structural Performance Load Test	S214	G1
2.2	Full-Scale Confirmatory Load Test	S214	G2
2.3	Full Scale Structural Performance Load Test	S214	G3

AISI COMMITTEE ON FRAMING STANDARDS

Richard Haws, <i>Chairman</i>	Nucor Corporation
Steve Fox, <i>Vice Chairman</i>	Canadian Sheet Steel Building Institute
Helen Chen, <i>Secretary</i>	American Iron and Steel Institute
Don Allen	Super Stud Building Products
Bill Babich	Alpine TrusSteel
Brad Cameron	Cameron & Associates Engineering, LLC
Randy Daudet	Simpson Strong-Tie
Jim DesLaurier	Certified Steel Stud Association
Scott Douglas	National Council of Structural Engineers Associations
Nader Elhajj	FrameCAD Solutions
Pat Ford	Steel Framing Industry Association
Jeff Klaiman	ADTEK Engineers
Roger LaBoube	Wei-Wen Yu Center for Cold-Formed Steel Structures
Rob Madsen	Supreme Steel Framing System Association
Cris Moen	Virginia Polytechnic Institute and State University
Kenneth Pagano	Scosta Corporation
Mike Pellock	Aegis Metal Framing
Nabil Rahman	The Steel Network, Inc.
Greg Ralph	ClarkDietrich Building Systems
Ben Schafer	Johns Hopkins University
Fernando Sesma	California Expanded Metal Products
Sutton Stephens	Pacific Northwest Engineering, Inc.
Steven Walker	Light Gauge Steel Engineering Group, Inc.
Robert Wessel	Gypsum Association
Lei Xu	University of Waterloo
Cheng Yu	University of North Texas
Rahim Zadeh	Steel Stud Manufacturers Association
Ron Ziemian	Structural Stability Research Council

GENERAL PROVISIONS SUBCOMMITTEE

Don Allen, <i>Chairman</i>	Super Stud Building Products
Helen Chen, <i>Secretary</i>	American Iron and Steel Institute
Bill Babich	Alpine TrusSteel
Randy Daudet	Simpson Strong-Tie
Jim DesLaurier	Certified Steel Stud Association
Scott Douglas	National Council of Structural Engineers Associations
Nader Elhajj	FrameCAD Solutions
Pat Ford	Steel Framing Industry Association
Douglas Fox	TotalJoist by iSPAN Systems
Steve Fox	Canadian Sheet Steel Building Institute
Richard Haws	Nucor Corporation
Jeff Klaiman	ADTEK Engineers
Roger LaBoube	Wei-Wen Yu Center for Cold-Formed Steel Structures
Stephen Linch	Telling Industries
Rob Madsen	Supreme Steel Framing System Association
Brian McGloughlin	MBA Building Supplies
Kenneth Pagano	Scosta Corporation
Greg Ralph	ClarkDietrich Building Systems
Ben Schafer	Johns Hopkins University
Fernando Sesma	California Expanded Metal Products
Robert Wessel	Gypsum Association
Rahim Zadeh	Steel Stud Manufacturers Association
Michael Zeeuw	Quail Run Building Materials, Inc.

DESIGN METHODS SUBCOMMITTEE

Roger LaBoube, <i>Chairman</i>	Wei-Wen Yu Center for Cold-Formed Steel Structures
Helen Chen, <i>Secretary</i>	American Iron and Steel Institute
Don Allen	Super Stud Building Products
Bill Babich	Alpine TrusSteel
Brad Cameron	Cameron & Associates Engineering, LLC
Jim DesLaurier	Certified Steel Stud Association
Nader Elhajj	FrameCAD Solutions
Pat Ford	Steel Framing Industry Association
Douglas Fox	TotalJoist by iSPAN Systems
Steve Fox	Canadian Sheet Steel Building Institute
Perry Green	Bechtel Power Corporation
Jeff Klaiman	ADTEK Engineers
Yanqi Li	Tongji University
Stephen Linch	Telling Industries
Rob Madsen	Supreme Steel Framing System Association
Brian McGloughlin	MBA Building Supplies
Cris Moen	Virginia Polytechnic Institute and State University
Robert Paullus	National Council of Structural Engineers Associations
Mike Pellock	Aegis Metal Framing
Nabil Rahman	The Steel Network, Inc.
Greg Ralph	ClarkDietrich Building Systems
Ben Schafer	Johns Hopkins University
Reynaud Serrette	Santa Clara University
Fernando Sesma	California Expanded Metal Products
Randy Shackelford	Simpson Strong-Tie
Sutton Stephens	Pacific Northwest Engineering, Inc.
Lei Xu	University of Waterloo
Cheng Yu	University of North Texas
Rahim Zadeh	Steel Stud Manufacturers Association

LATERAL DESIGN SUBCOMMITTEE

Rob Madsen, <i>Chairman</i>	Supreme Steel Framing System Association
Helen Chen, <i>Secretary</i>	American Iron and Steel Institute
Don Allen	Super Stud Building Products
Brad Cameron	Cameron & Associates Engineering, LLC
Nader Elhajj	FrameCAD Solutions
Bill Gould	Hilti, Inc.
Perry Green	Bechtel Power Corporation
Rick Haws	Nucor Corporation
Roger LaBoube	Wei-Wen Yu Center for Cold-Formed Steel Structures
Stephen Linch	Telling Industries
Cris Moen	Virginia Polytechnic Institute and State University
J.R. Mujagic	Uzun & Case Engineers LLC
Ashwin Mupparapu	Structuneering, Inc.
Robert Paullus	National Council of Structural Engineers Associations
Nabil Rahman	The Steel Network, Inc.
Greg Ralph	ClarkDietrich Building Systems
Colin Rogers	McGill University
Ben Schafer	Johns Hopkins University
Reynaud Serrette	Santa Clara University
Fernando Sesma	California Expanded Metal Products
Randy Shackelford	Simpson Strong-Tie
K.S. Sivakumaran	McMaster University
Chia-Ming Uang	University of California, San Diego
Lei Xu	University of Waterloo
Henry Yektai	Paco Steel Engineering
Cheng Yu	University of North Texas
Rahim Zadeh	Steel Stud Manufacturers Association

STANDARD PRACTICES SUBCOMMITTEE

Jeff Klaiman, <i>Chairman</i>	ADTEK Engineers
Helen Chen, <i>Secretary</i>	American Iron and Steel Institute
Don Allen	Super Stud Building Products
Bill Babich	ITW Building Components Group
Darden Cobb	Loadmaster Systems, Inc.
Randy Daudet	Simpson Strong-Tie
Jim DesLaurier	Certified Steel Stud Association
Nader Elhajj	FrameCAD Solutions
Pat Ford	Steel Framing Industry Association
Kirk Grundahl	SBCA Cold-Formed Steel Council
Stephen Linch	Telling Industries
Rob Madsen	Supreme Steel Framing System Association
Brian McGloughlin	MBA Building Supplies
Kenneth Pagano	Scosta Corporation
Robert Paullus	National Council of Structural Engineers Associations
Mike Pellock	Aegis Metal Framing
Nabil Rahman	The Steel Network, Inc.
Greg Ralph	ClarkDietrich Building Systems
Fernando Sesma	California Expanded Metal Products
Tom Sputo	Steel Deck Institute
Steven Walker	Light Gauge Steel Engineering Group, Inc.
Rahim Zadeh	Steel Stud Manufacturers Association

TRUSS DESIGN SUBCOMMITTEE

Bill Babich, <i>Chairman</i>	ITW Building Components Group
Helen Chen, <i>Secretary</i>	American Iron and Steel Institute
Brad Cameron	Cameron & Associates Engineering, LLC
Scott Douglas	National Council of Structural Engineers Associations
Nader Elhajj	FrameCAD Solutions
Perry Green	Bechtel Power Corporation
Kirk Grundahl	SBCA Cold-Formed Steel Council
Jeff Klaiman	ADTEK Engineers
Roger LaBoube	Wei-Wen Yu Center for Cold-Formed Steel Structures
Stephen Linch	Telling Industries
Kenneth Pagano	Scosta Corporation
Anwar Merchant	Keymark
Cris Moen	Virginia Polytechnic Institute and State University
Kenneth Pagano	Scosta Corporation
Mike Pellock	Aegis Metal Framing
Randy Shackelford	Simpson-Strong Tie
Steven Walker	Light Gauge Steel Engineering Group, Inc.
Lei Xu	University of Waterloo

SYMBOLS

Symbol	Definition	Section
A_c	Gross cross-sectional area of <i>chord member</i> , in square inches (mm ²)	B5.2.5, B5.4.4.1
A_g	Gross area of the clip angle <i>bearing stiffener</i>	B2.5.1
a	Distance between center line of braces	B2.6, B4.5
a	Wall aspect ratio	B5.2.2.3.2.1
b	Length of the <i>shear wall</i> , in inches (mm)	B5.2.5
b	<i>Diaphragm</i> depth parallel to direction of <i>load</i> , in inches (mm)	B5.4.4.1
b	Effective width determined in accordance with Section B2.1 of AISI S100 [CSA S136] with $f=F_y$, $k=4$ and $w=W_{\min}$	E4.5.1
C	Web crippling coefficient	B3.2.5.1
C	Uplift anchorage force contributed from each level, lbs [kN]	B5.2.4.2.2
C	Uplift anchorage force, lbs [kN]	B5.2.4.2.3
C	Boundary chord force (tension/compression), lbs [kN]	B5.3.4.2
C_a	Shear resistance adjustment factor from Table B5.2.2.2-1. For intermediate values of opening height ratio and percentages of full-height sheathing, the shear resistance adjustment factors are permitted to be determined by interpolation.	B5.2.2.2, B5.2.4.1.2, B5.2.4.2.3
C_b	Bending coefficient dependent on moment gradient	E4.4.2.2
C_h	<i>Web</i> slenderness coefficient	B3.2.5.1
C_m	End moment coefficient in interaction formula	E4.4.2.1
C_N	Bearing length coefficient	B3.2.5.1
C_R	Inside bend radius coefficient	B3.2.5.1
c	Length of cope	E4.6.2.1
D	Dead <i>load</i>	B1.2.2.4, B5.2.2.3.3
d	Depth of <i>C-shape</i> section	B2.6, B4.5
d_c	Depth of cope	E4.6.2.1
E_s	Modulus of elasticity of steel = 29,500,000 psi (203,000 MPa)	B5.2.5, B5.4.4.1
e	Design end or slip gap (distance between <i>stud web</i> at end of <i>stud</i> and <i>track web</i>)	B3.2.5.2.2

SYMBOLS

Symbol	Definition	Section
e	Eccentricity of compression force with respect to the centroid of the full section of the <i>web member</i>	E4.4.4.1
EI_w	Sheathing bending rigidity	1.3
F	Concentrated design <i>load</i> [<i>factored load</i>]	B2.6, B4.5
F	Furring channels	A5.3.1
F	wa	B2.6, B4.5
F_c	Critical buckling stress	E4.4.2.2
F_m	Mean value of the fabrication factor	B5.4.5
F_y	<i>Yield strength</i> of clip angle	B2.5.1
F_y	Design <i>yield strength</i> of <i>track</i> material	B3.2.5.2.2
F_y	<i>Yield strength</i> used for design	B1.2.1.1, B3.3.3.1.1, B3.3.4.1.1, E4.4.2.2
F_y	Specified minimum <i>yield strength</i>	E4.5.1
F_y	Yield stress of steel sheet sheathing	B5.2.2.3.2.1
F_{uf}	Minimum tensile strength of framing materials	B5.2.2.3.2.1
F_{ush}	Tensile strength of steel sheet sheathing	B5.2.2.3.2.1
F_{ut}	Tensile strength of the <i>track</i>	B3.2.5.1
G	Shear modulus of sheathing material, in pounds per square inch (MPa)	B5.2.5, B5.4.4.1
h	Depth of flat portion of <i>stud web</i> measured along plane of <i>web</i>	B3.2.5.1
h	Height of the <i>shear wall</i> , ft. [m]	B5.2.1.1, B5.2.1.2, B5.2.2.1, B5.2.4.2.2, B5.2.4.2.3
h	Wall height, in inches (mm)	B5.2.5
h	<i>Strap braced wall</i> height, feet [m]	B5.3.4.2
h	Flat width of <i>web</i> of section being coped	E4.6.2.1
h_p	Height of a <i>wall pier</i>	B5.2.1.1
I_{min}	Moment of inertia determined with respect to an axis parallel to the <i>web</i> of the <i>chord member</i>	E4.6.2.1

SYMBOLS

Symbol	Definition	Section
KL	Effective length	B3.2.1.1, E4.4.2.1
K_t	Effective length factor for torsion	B3.2.1.1, E4.4.2.1, E4.4.2.2
K_x	Effective length factor for buckling about x-axis	B3.2.1.1, E4.4.2.1, E4.4.2.2
K_y	Effective length factor for buckling about y-axis	B3.2.1.1, E4.4.2.1, E4.4.2.2
k_ϕ	Rotational stiffness	B2.2.1.2, B2.3.2.2, B2.3.3.2, B3.2.1.2, B3.2.2.2, B4.2.2.2, B4.2.3.2, 1.1, 1.2, 1.3
$k_{\phi c}$	Connection rotational restraint	1.3
$k_{\phi w}$	Sheathing rotational restraint	1.3
L	Angle or L-header	A5.3.1
L	Live load	B1.2.2.4
L	Span length	B3.3.3.1.1
L	Length of <i>Type I shear wall</i> , feet [m]	B5.2.4.1.1
L	Length of <i>Type I shear wall</i> including anchor offsets, feet [m]	B5.2.4.2.2
L	Length of <i>strap braced wall</i> including anchor offsets, feet [m]	B5.3.4.2
L	<i>Diaphragm</i> length perpendicular to direction of load, in inches (mm)	B5.4.4.1
L	Unbraced length of the compression <i>web member</i>	E4.4.4.1
L	Length of <i>truss</i>	E6.1.1
L_{eff}	Average length between the last rows of fasteners of adjacent <i>truss</i> members in the <i>connection</i>	E4.5.1
L_h	Vertical leg dimension of angle	B3.3.3.1.1, B3.3.3.1.2
L_m	Distance between braces	B2.2.1.2, B2.3.2.2, B2.3.3.2, B3.2.1.2, B3.2.2.2, B4.2.2.2, B4.2.3.2
L_t	Unbraced length of compression member for torsion	B3.2.1.1, E4.4.2.1, E4.4.2.2
L_x	Unbraced length of compression member for bending about x-axis	B3.2.1.1, E4.4.2.1, E4.4.2.2
L_y	Unbraced length of compression member for bending about y-axis	B3.2.1.1, E4.4.2.1, E4.4.2.2

SYMBOLS

Symbol	Definition	Section
L_1, L_2	One-half joist spacing to the first and second sides respectively, as illustrated in Figure B8.2-1	1.3
M	<i>Required flexural strength</i>	B3.3.2.5
M_m	Mean value of the material factor	B5.4.5
M_n	<i>Nominal flexural strength</i> defined in Section C3.1 of AISI S100 [CSA S136]	B3.3.2.5
M_n	<i>Nominal flexural strength [resistance]</i> defined in Section C3.1 of AISI S100 [CSA S136]	B3.3.2.5
M_n	<i>Nominal flexural strength [resistance]</i>	E4.4.2.2
M_{ng}	<i>Gravity nominal flexural strength [moment resistance]</i>	B3.3.3.1.1, B3.3.3.1.2, B3.3.4.1.1
M_{nu}	<i>Nominal uplift flexural strength [moment resistance]</i>	B3.3.3.1.2
M_{nxo}	<i>Nominal flexural strength [resistance]</i> determined at $f = F_y$	E4.4.2.3
M_u	<i>Required flexural strength [moment due to factored loads]</i>	B3.3.2.5
M_x	<i>Required flexural strength</i>	E4.4.2.3
\bar{M}_x	<i>Required flexural strength [moment of factored loads]</i>	E4.4.2.3
m	Distance from shear center to mid-plane of <i>web</i>	B2.6, B4.5
N	<i>Stud bearing length</i>	B3.2.5.1
n	Number of <i>chord</i> splices in <i>diaphragm</i> (considering both <i>diaphragm chords</i>)	B5.4.4.1
n	Number of connections in the assembly with the same tributary area	B5.4.5
P	<i>Required web crippling strength</i>	B3.3.2.5
P	<i>Required compressive axial strength</i>	E4.4.2.3
P_j	End two-flange <i>web</i> crippling capacity of the <i>floor joist</i>	B2.5.1
P_L	Required lateral force	B2.6, B4.5
P_n	<i>Nominal web crippling strength [resistance]</i>	B3.3.2.3
P_n	<i>Nominal web crippling strength</i> determined in accordance with Section B3.3.2.3	B3.3.2.5
P_n	<i>Nominal web crippling strength [resistance]</i> computed by Section B3.3.2.3	B3.3.2.5
P_n	Nominal shear strength [resistance] of screw connections	B5.2.2.3.2.1

SYMBOLS

Symbol	Definition	Section
	within the effective strip width, W_e , on the steel sheet sheathing	
P_n	Nominal axial strength [resistance] based on Section C4.1 of AISI S100 [CSA S136]. Only flexural buckling need be considered.	E4.4.4.1
P_n	Nominal axial compressive strength [resistance]	E4.5
P_{no}	Nominal axial strength [resistance] determined at $f = F_y$	E4.4.2.3
P_{ndt}	Nominal strength [resistance] of a single deflection track subjected to transverse loads and connected to its support at a fastener spacing not greater than the stud spacing	B3.2.5.2.2
P_{nst}	Nominal strength for the stud-to-track connection when subjected to transverse loads	B3.2.5.1, B3.2.5.2.1
P_{nst}	Nominal web crippling strength [resistance]	B3.2.5.2.1
P_t	Interior two-flange web crippling capacity of the rim track	B2.5.1
P_u	Required web crippling strength [compression force due to factored loads]	B3.3.2.5
\bar{P}	Required compressive axial strength [axial force of factored loads]	E4.4.2.3
R	Seismic response modification coefficient	A1.3
R	Stud inside bend radius	B3.2.5.1
R	Uplift factor	B3.3.3.1.2
R	Required concentrated load strength	E4.4.2.3
R	Modification factor	E4.4.4
R	Reduction factor	E4.6.2.1
\bar{R}	Required concentrated load strength [factored concentrated load]	E4.4.2.3
$R_d R_o$	Seismic force modification factors	A1.3
R_n	Nominal interior one-flange loading web crippling strength [resistance]	E4.4.2.3
r	Radius of gyration of the full section about the minor axis	E4.4.4.1
S	Snow load	B1.2.2.4
S	Stud or joist framing member which has lips	A5.3.1
S	Center-to-center spacing of studs	B3.2.5.2.2

SYMBOLS

Symbol	Definition	Section
S_c	Elastic section modulus of effective section calculated relative to extreme compression fiber at F_c	E4.4.2.2
S_e	Elastic section modulus of effective section calculated relative to extreme compression fiber at F_y	E4.4.2.2
S_{ec}	Elastic section modulus of the effective section calculated at $f = F_y$ in the extreme compression fibers	B3.3.3.1.1, B3.3.4.1.1
S_n	<i>Nominal shear strength [resistance]</i>	B5.4.5
ST	Specified standard term load based on snow or occupancy loads acting alone or in combination	B5.2.2.3.3
s	Maximum fastener spacing at panel edges, in inches (mm)	B5.2.5, B5.4.4.1
s	Screw spacing on the panel edges	B5.2.2.3.2.1
T	<i>Track section</i>	A5.3.1
T_{sh}	Design thickness of steel sheet sheathing	B5.2.2.3.2.1
T_f	Minimum design thicknesses of framing members	B5.2.2.3.2.1
t	Design thickness of steel sheet sheathing	B5.2.2.3.2.1
t	<i>Stud design thickness</i>	B3.2.5.1
t	<i>Design thickness</i>	B3.3.3.1.2
t	<i>Design thickness of gusset plate</i>	E4.5.1
t	<i>Design thickness of section being coped</i>	E4.6.2.1
t_c	<i>Design thickness of the C-shape section</i>	B3.3.2.3
t_t	<i>Track design thickness</i>	B3.2.5.1, B3.2.5.2.2
t_t	<i>Track design thickness</i>	B3.3.2.3, B3.2.5.1
$t_{sheathing}$	Nominal panel thickness, in inches (mm)	B5.2.5, B5.4.4.1
t_{stud}	Framing designation thickness, in inches (mm)	B5.2.5, B5.4.4.1
U	Channel or <i>stud</i> framing section which does not have <i>lips</i>	A5.3.1
V	Shear force in <i>Type I shear wall</i> , lbs [kN]	B5.2.4.1.1, B5.2.4.1.2, B5.2.4.2.2
V	Shear force in <i>Type II shear wall</i> , lbs [kN]	B5.2.4.2.3
V	Total lateral load applied to the <i>shear wall</i> , in pounds (N)	B5.2.5
V	Shear force in <i>strap braced wall</i> , lbs [kN]	B5.3.4.2
V	Total lateral load applied to the <i>diaphragm</i> , in pounds (N)	B5.4.4.1
V_F	Coefficient of variation of fabrication factor	B5.4.5

SYMBOLS

Symbol	Definition	Section
V_M	Coefficient of variation of material factor	B5.4.5
V_n	<i>Nominal strength [resistance]</i> for shear	B5.2.1.2, B5.2.2.1, B5.2.2.2
V_P	Actual calculated coefficient of variation of the test results, without limit	B5.4.5
V_Q	Coefficient of variation of the load effect	B5.4.5
v_n	<i>Nominal strength [resistance]</i> per unit length as specified in Section B5.2.2.3, lbs./ft. [kN/m]	B5.2.2.1, B5.2.2.2
v	Unit shear force, plf [kN/m]	B5.2.4.1.1, B5.2.4.1.2
v	Shear demand, in pounds per linear inch (N/mm) = V/b	B5.2.5
v	Shear demand, in pounds per linear inch (N/mm) = $V/(2b)$	B5.4.4.1
W	Wind load	B1.2.2.4
w_e	Effective width	B5.2.2.3.2.1
W_m	Lesser of the actual <i>gusset plate</i> width or Whitmore section	E4.5.1
w	Uniform <i>design load [factored load]</i>	B2.6, B4.5
w	Length of the <i>shear wall</i> , ft. [m]	B5.2.1.1, B5.2.1.2, B5.2.2.1
w_p	Length of a <i>wall pier</i>	B5.2.1.1
w_{dt}	Effective track length	B3.2.5.2.2
w_{st}	$20 t_t + 0.56\alpha$	B3.2.5.1
X_i	Distance between the “ <i>ith</i> ” <i>chord-splice</i> and the nearest support, in inches (mm)	B5.4.4.1
x	Distance from concentrated <i>load</i> to brace	B2.6, B4.5
α	Coefficient for conversion of units	B3.2.5.1, B3.2.5.2.2, B3.3.2.3
α	Parameter determined in accordance with Equation B3.3.2.3-1 or B3.3.2.3-2	B3.3.2.3
α	Ratio of the average <i>load</i> per fastener based on a non-uniform fastener pattern to the average <i>load</i> per fastener based on a uniform fastener pattern (= 1 for a uniformly fastened <i>diaphragm</i>)	B5.4.4.1
$\alpha, \alpha_1, \alpha_2$	Variables	B5.2.2.3.2.1

SYMBOLS

Symbol	Definition	Section
β	Factor used on deflection calculation	B5.2.5, B5.4.4.1
β_o	Target reliability index	B5.4.5
$\beta_1, \beta_2, \beta_3$	Variables	B5.2.2.3.2.1
ρ	Factor used on deflection calculation	B5.2.5, B5.4.4.1
ρ	Variable	B5.2.2.3.2.1
δ	Calculated deflection, in inches (mm)	B5.2.5
δ_b	Deflection of blocked <i>diaphragm</i> determined in accordance with Eq. B5.4.4-1	B5.4.4.2, B5.4.4, B5.4.4.1
δ_{ub}	Deflection of an unblocked <i>diaphragm</i>	B5.4.4.2
δ_v	Vertical deformation of anchorage/ attachment details, in inches (mm)	B5.2.5
ΣL_i	Sum of lengths of <i>Type II shear wall segments</i> , ft. [m]	B5.2.2.2, B5.2.4.1.2, B5.2.4.2.3
Δ_{ci}	Deformation value associated with “ith” <i>chord splice</i> , in inches (mm)	B5.4.4.1
$\omega_1, \omega_2, \omega_3, \omega_4$	Factors used in deflection calculation	B5.2.5, B5.4.4.1
ϕ	<i>Resistance factor</i>	B3.2.5.1, B3.2.5.2.1, B3.2.5.2.2, B3.3.2.3, B3.3.2.5, B3.3.3.1.1, B3.3.3.1.2, B3.3.4.1.1, B5.2.3, E4.4.2.3
ϕ_c	<i>Resistance factor</i>	B2.5.1, E4.5.1
ϕ_v	<i>Resistance factor</i>	B5.2.3, B5.4.3
Ω	<i>Safety factor</i>	B3.2.5.1, B3.2.5.2.1, B3.2.5.2.2, B3.3.2.3, B3.3.2.5, B3.3.3.1.1, B3.3.3.1.2, B3.3.4.1.1, B5.2.3, E4.4.2.3
Ω_c	<i>Safety factor</i>	B2.5.1, E4.5.1
Ω_v	<i>Safety factor</i>	B5.2.3, B5.4.3

TABLE OF CONTENTS
NORTH AMERICAN STANDARD
FOR COLD-FORMED STEEL STRUCTURAL FRAMING

Disclaimer	ii
Preface	v
Section Reference Between AISI S240 and AISI S200, S210, S211, S212, S213, and S214.....	vii
AISI Committee on Framing Standards.....	xiii
General Provisions Subcommittee.....	xiv
Design Methods Subcommittee	xv
Lateral Design Subcommittee	xvi
Standard Practices Subcommittee	xvii
Truss Design Subcommittee.....	xviii
NORTH AMERICAN STANDARD FOR COLD-FORMED STEEL STRUCTURAL FRAMING	1
A. GENERAL	1
A1 Scope.....	1
A2 Definitions	1
A2.1 Terms.....	1
A3 Material.....	8
A4 Corrosion Protection	8
A5 Products	9
A5.1 Base Steel Thickness.....	9
A5.2 Minimum Flange Width.....	9
A5.3 Product Designator	9
A5.4 Manufacturing Tolerances	9
A5.5 Product Identification	11
A5.5.1 Identification of Groups of Like Members	11
A5.5.2 Identification of Individual Framing Members.....	11
A6 Reference Documents	11
B. DESIGN	14
B1 General.....	14
B1.1 Loads and Load Combinations.....	14
B1.1.1 Application of Live Load Reduction on Wall Studs	14
B1.1.2 Application of Wind Loads on Wall Studs in the United States and Mexico.....	14
B1.2 Design Basis.....	14
B1.2.1 Floor Joists, Ceiling Joists and Roof Rafters	14
B1.2.2 Wall Studs	15
B1.2.3 In-Line Framing.....	16
B1.2.4 Sheathing Span Capacity	16
B1.2.5 Load Path	16
B1.2.6 Principles of Mechanics.....	17
B1.3 Built-Up Section Design	17
B1.4 Properties of Sections.....	17
B1.5 Connection Design	17
B1.5.1 Screw Connections.....	18
B1.5.1.1 Steel-to-Steel Screws.....	18
B1.5.1.2 Sheathing Screws.....	18
B1.5.1.3 Spacing and Edge Distance.....	18
B1.5.1.4 Gypsum Board.....	18

B1.5.2	Welded Connections.....	18
B1.5.3	Bolts.....	18
B1.5.4	Power-Actuated Fasteners.....	18
B1.5.5	Other Connectors.....	18
B1.5.6	Connection to Other Materials.....	19
B2	Floor and Ceiling Framing.....	19
B2.1	Scope.....	19
B2.2	Floor Joist Design.....	19
B2.2.1	Bending.....	19
B2.2.1.1	Lateral-Torsional Buckling.....	19
B2.2.1.2	Distortional Buckling.....	19
B2.2.2	Shear.....	19
B2.2.3	Web Crippling.....	20
B2.2.4	Bending and Shear.....	20
B2.2.5	Bending and Web Crippling.....	20
B2.3	Ceiling Joist Design.....	20
B2.3.1	Tension.....	20
B2.3.2	Compression.....	20
B2.3.2.1	Yielding, Flexural, Flexural-Torsional and Torsional Buckling.....	20
B2.3.2.2	Distortional Buckling.....	20
B2.3.3	Bending.....	20
B2.3.3.1	Lateral-Torsional Buckling.....	20
B2.3.3.2	Distortional Buckling.....	21
B2.3.4	Shear.....	21
B2.3.5	Web Crippling.....	21
B2.3.6	Axial Load and Bending.....	21
B2.3.7	Bending and Shear.....	21
B2.3.8	Bending and Web Crippling.....	21
B2.4	Floor Truss Design.....	21
B2.5	Bearing Stiffeners.....	22
B2.5.1	Clip Angle Bearing Stiffeners.....	22
B2.6	Bracing Design.....	23
B2.7	Floor Diaphragm Design.....	24
B3	Wall Framing.....	24
B3.1	Scope.....	24
B3.2	Wall Stud Design.....	24
B3.2.1	Available Axial Strength [Factored Resistance].....	24
B3.2.1.1	Yielding, Flexural, Flexural-Torsional and Torsional Buckling.....	24
B3.2.1.2	Distortional Buckling.....	25
B3.2.2	Bending.....	25
B3.2.2.1	Lateral-Torsional Buckling.....	25
B3.2.2.2	Distortional Buckling.....	26
B3.2.3	Shear.....	26
B3.2.4	Axial Load and Bending.....	26
B3.2.5	Web Crippling.....	26
B3.2.5.1	Stud-to-Track Connection for C-Section Studs.....	26
B3.2.5.2	Deflection Track Connection for C-Section Studs.....	30
B3.3	Header Design.....	31

B3.3.1	Back-to-Back Headers.....	31
B3.3.1.1	Bending.....	31
B3.3.1.2	Shear.....	31
B3.3.1.3	Web Crippling.....	31
B3.3.1.4	Bending and Shear.....	31
B3.3.1.5	Bending and Web Crippling.....	31
B3.3.2	Box Headers.....	32
B3.3.2.1	Bending.....	32
B3.3.2.2	Shear.....	32
B3.3.2.3	Web Crippling.....	32
B3.3.2.4	Bending and Shear.....	32
B3.3.2.5	Bending and Web Crippling.....	32
B3.3.3	Double L-Headers.....	33
B3.3.3.1	Bending.....	34
B3.3.3.1.1	Gravity Loading.....	34
B3.3.3.1.2	Uplift Loading.....	34
B3.3.3.2	Shear.....	35
B3.3.3.3	Web Crippling.....	35
B3.3.3.4	Bending and Shear.....	35
B3.3.3.5	Bending and Web Crippling.....	35
B3.3.4	Single L-Headers.....	35
B3.3.4.1	Bending.....	35
B3.3.4.1.1	Gravity Loading.....	35
B3.3.4.1.2	Uplift Loading.....	36
B3.3.4.2	Shear.....	36
B3.3.4.3	Web Crippling.....	36
B3.3.4.4	Bending and Shear.....	36
B3.3.4.5	Bending and Web Crippling.....	36
B3.3.5	Inverted L-Header Assemblies.....	36
B3.4	Bracing.....	37
B3.4.1	Intermediate Brace Design.....	37
B3.5	Serviceability.....	37
B4	Roof Framing.....	37
B4.1	Scope.....	37
B4.2	Roof Rafter Design.....	37
B4.2.1	Tension.....	37
B4.2.2	Compression.....	37
B4.2.2.1	Yielding, Flexural, Flexural-Torsional and Torsional Buckling.....	37
B4.2.2.2	Distortional Buckling.....	37
B4.2.3	Bending.....	38
B4.2.3.1	Lateral-Torsional Buckling.....	38
B4.2.3.2	Distortional Buckling.....	38
B4.2.4	Shear.....	38
B4.2.5	Web Crippling.....	38
B4.2.6	Axial Load and Bending.....	38
B4.2.7	Bending and Shear.....	39
B4.2.8	Bending and Web Crippling.....	39
B4.3	Roof Truss Design.....	39

B4.4	Bearing Stiffeners.....	39
B4.5	Bracing Design.....	39
B4.6	Roof Diaphragm Design.....	40
B5	Lateral Force-Resisting Systems.....	40
B5.1	Scope.....	40
B5.2	Shear Wall Design.....	40
B5.2.1	General.....	40
B5.2.1.1	Type I Shear Walls.....	40
B5.2.1.2	Type II Shear Walls.....	41
B5.2.2	Nominal Strength [Resistance].....	41
B5.2.2.1	Type I Shear Walls.....	41
B5.2.2.2	Type II Shear Walls.....	41
B5.2.2.3	Nominal Strength [Resistance] per Unit Length.....	42
B5.2.2.3.1	General Requirements.....	42
B5.2.2.3.2	Steel Sheet Sheathing.....	43
B5.2.2.3.2.1	Effective Strip Method.....	43
B5.2.2.3.3	Wood Structural Panel Sheathing.....	44
B5.2.2.3.4	Gypsum Board Panel Sheathing.....	45
B5.2.2.3.5	Fiberboard Panel Sheathing.....	45
B5.2.2.3.6	Combined Systems.....	45
B5.2.3	Available Strength [Factored Resistance].....	50
B5.2.4	Collectors and Anchorage.....	50
B5.2.4.1	Collectors and Anchorage for In-Plane Shear.....	50
B5.2.4.1.1	Type I Shear Walls.....	50
B5.2.4.1.2	Type II Shear Walls.....	50
B5.2.4.2	Uplift Anchorage at Wall Ends.....	50
B5.2.4.2.1	General.....	51
B5.2.4.2.2	Type I Shear Walls.....	51
B5.2.4.2.3	Type II Shear Walls.....	51
B5.2.4.3	Uplift Anchorage Between Type II Shear Wall Ends.....	51
B5.2.5	Design Deflection.....	51
B5.3	Strap Braced Wall Design.....	53
B5.3.1	General.....	53
B5.3.2	Nominal Strength [Resistance].....	53
B5.3.3	Available Strength [Factored Resistance].....	53
B5.3.4	Collectors and Anchorage.....	53
B5.3.4.1	Collectors and Anchorage for In-Plane Shear.....	53
B5.3.4.2	Uplift Anchorage at Wall Ends.....	53
B5.3.5	Design Deflection.....	54
B5.4	Diaphragm Design.....	54
B5.4.1	General.....	54
B5.4.2	Nominal Strength.....	55
B5.4.3	Available Strength.....	55
B5.4.4	Design Deflection.....	55
B5.4.4.1	Blocked Diaphragms.....	56
B5.4.4.2	Unblocked Diaphragms.....	56
B5.4.5	Beam Diaphragm Tests for Non-Steel Sheathed Assemblies.....	57

C. INSTALLATION	58
C1 General.....	58
C2 Material Condition	58
C2.1 Web Holes.....	58
C2.2 Cutting and Patching.....	58
C2.3 Splicing.....	58
C3 Structural Framing	58
C3.1 Foundation	58
C3.2 Ground Contact	59
C3.3 Floors.....	59
C3.3.1 Plumbness and Levelness.....	59
C3.3.2 Alignment	59
C3.3.3 Bearing Width.....	59
C3.3.4 Web Separation	59
C3.4 Walls.....	59
C3.4.1 Straightness, Plumbness and Levelness	59
C3.4.2 Alignment	59
C3.4.3 Stud-to-Track Connection.....	59
C3.4.4 Back-to-Back and Box Headers	60
C3.4.5 Double and Single L-Headers	60
C3.4.6 Inverted L-Header Assemblies	60
C3.5 Roofs and Ceilings.....	62
C3.5.1 Plumbness and Levelness.....	62
C3.5.2 Alignment	62
C3.5.3 End Bearing.....	62
C3.6 Lateral Force-Resisting Systems	62
C3.6.1 Shear Walls	62
C3.6.2 Strap Braced Walls.....	62
C3.6.3 Diaphragms	62
C4 Connections	62
C4.1 Screw Connections	63
C4.1.1 Steel-to-Steel Screws	63
C4.1.2 Installation	63
C4.1.3 Stripped Screws.....	63
C4.2 Welded Connections	63
C5 Miscellaneous.....	63
C5.1 Utilities	63
C5.1.1 Holes	63
C5.1.2 Plumbing.....	63
C5.1.3 Electrical.....	63
C5.2 Insulation.....	64
C5.2.1 Mineral Fiber Insulation.....	64
C5.2.2 Other Insulation	64
D. QUALITY CONTROL AND QUALITY ASSURANCE.....	65
D1 General.....	65
D1.1 Scope and Limits of Applicability.....	65
D1.2 Responsibilities	65
D2 Quality Control Programs.....	65

D3 Quality Control Documents.....	66
D3.1 Documents to be Submitted.....	66
D3.1.1 Additional Requirements for Lateral Force-Resisting Systems.....	66
D3.1.1.1 Component Assemblies.....	66
D3.1.1.2 Other Than Component Assemblies.....	66
D3.1.1.3 Exceptions to Sections D3.1.1.1 and D3.1.1.2.....	66
D3.2 Available Documents.....	66
D4 Quality Assurance Agency Documents	67
D5 Inspection Personnel.....	67
D5.1 Quality Control Inspector.....	67
D5.2 Quality Assurance Inspector.....	68
D6 Inspection Tasks.....	68
D6.1 General.....	68
D6.2 Quality Control Inspection Tasks.....	68
D6.3 Quality Assurance Inspection Tasks.....	68
D6.4 Coordinated Inspection	69
D6.5 Material Verification	69
D6.6 Inspection of Welding.....	70
D6.7 Inspection of Mechanical Fastening.....	71
D6.8 Inspection of Cold-Formed Steel Light-Frame Construction.....	72
D6.9 Additional Requirements for Lateral Force-Resisting Systems	72
D6.9.1 Fit-up of Welds.....	73
D7 Nonconforming Material and Workmanship.....	74
D7.1 Additional Inspections.....	74
D7.2 Rejection of Material	74
E. TRUSSES.....	75
E1 General.....	75
E1.1 Scope and Limits of Applicability.....	75
E2 Truss Responsibilities	75
E3 Loading.....	75
E4 Truss Design.....	75
E4.1 Materials	75
E4.2 Corrosion Protection	75
E4.3 Analysis.....	75
E4.4 Member Design.....	75
E4.4.1 Properties of Sections	75
E4.4.2 Compression Chord Members.....	76
E4.4.3 Tension Chord Members	79
E4.4.4 Compression Web Members	79
E4.4.5 Tension Web Members.....	79
E4.4.6 Eccentricity in Joints	80
E4.5 Gusset Plate Design.....	80
E4.6 Connection Design	81
E4.6.1 Fastening Methods.....	81
E4.6.2 Coped Connections for C-Shaped Sections.....	81
E4.7 Serviceability	82
E5 Quality Criteria for Steel Trusses	82
E5.1 Manufacturing Quality Criteria	82

E5.2 Member Identification	82
E5.3 Assembly	82
E6 Truss Installation	83
E6.1 Installation Tolerances	83
E6.1.1 Straightness	83
E6.1.2 Plumbness	83
E6.1.3 Top Chord Bearing Trusses	83
E7 Test-Based Design	83
F. TESTING	85
F1 General	85
F2 Truss Components and Assemblies	85
APPENDIX 1, CONTINUOUSLY BRACED DESIGN FOR DISTORTIONAL BUCKLING RESISTANCE.....	86
APPENDIX 2, TEST METHODS FOR TRUSS COMPONENTS AND ASSEMBLIES	89
2.1 Component Structural Performance Load Test	89
2.1.1 Flexural Test	89
2.1.1.1 Number of Test Specimens	89
2.1.1.2 Materials	89
2.1.1.3 Test Apparatus	89
2.1.1.4 Load and Deflection Measuring Devices	89
2.1.1.5 Loading Procedures	89
2.1.1.6 Interpretation of Test Results	89
2.1.1.7 Report	89
2.1.2 Compression Test	90
2.2 Full-Scale Confirmatory Load Test	90
2.2.1 Test Specimen	90
2.2.2 Number of Test Specimens	90
2.2.3 Materials	90
2.2.4 Fabrication	90
2.2.5 Test Apparatus	90
2.2.6 Load and Deflection Measuring Devices	91
2.2.7 Loading Procedures	91
2.2.7.1 Tests to Confirm Deflection	91
2.2.7.2 Tests to Confirm Available Strength [Factored Resistance] Assumptions	91
2.2.8 Interpretation of Test Results	92
2.2.9 Report	92
2.3 Full-Scale Structural Performance Load Test	92
2.3.1 Test Specimen	92
2.3.2 Number of Test Specimens	92
2.3.3 Materials	92
2.3.4 Fabrication	92
2.3.5 Test Apparatus	92
2.3.6 Load and Deflection Measuring Devices	93
2.3.7 Loading Procedures	93
2.3.8 Interpretation of Test Results	93
2.3.9 Report	94

This Page is Intentionally Left Blank.

NORTH AMERICAN STANDARD FOR COLD-FORMED STEEL STRUCTURAL FRAMING

A. GENERAL

A1 Scope

- A1.1** This Standard applies to the design and installation of *structural members and connections* utilized in *cold-formed steel light-frame construction* applications.
- A1.2** The design and installation of *cold-formed steel* framing for the following systems shall be in accordance with AISI S100 [CSA S136] and this Standard:
- (a) floor and roof systems in buildings,
 - (b) structural walls in buildings,
 - (c) *shear walls, strap braced walls and diaphragms* to resist in-plane lateral loads, and
 - (d) *trusses* for load-carrying purposes in buildings.
- A1.3** *Cold-formed steel structural members and connections in seismic force-resisting systems and diaphragms* shall be designed in accordance with the additional provisions of AISI S400 in the following cases:
- (a) In the U.S. and Mexico, in *seismic design categories (SDC) D, E, or F*, or wherever the *seismic response modification coefficient, R*, used to determine the seismic design forces is taken other than 3.
 - (b) In Canada, where the design spectral response acceleration $S(0.2)$ as specified in the NBCC is greater than 0.12 and the seismic force modification factors, $R_d R_o$, used to determine the seismic design forces, are taken as greater than or equal to 1.56.
- A1.4** *Cold-formed steel* framing for floor and roof systems, and structural walls, as listed in items A1.2(a) and A1.2(b), are also permitted to be designed solely in accordance with AISI S100 [CSA S136].
- A1.5** Elements not specifically addressed by this Standard shall be constructed in accordance with *applicable building code* requirements.
- A1.6** This Standard does not preclude the use of other materials, assemblies, structures or designs not meeting the criteria herein, when the other materials, assemblies, structures or designs demonstrate equivalent performance for the intended use to those specified in this Standard. Where there is a conflict between this Standard and other reference documents, the requirements contained within this Standard shall govern.
- A1.7** This Standard includes Chapters A through F and Appendices 1 and 2 in their entirety.

A2 Definitions

A2.1 Terms

Where the following terms appear in this Standard in italics, they shall have the meaning herein indicated. Terms included in square brackets shall be specific to *LSD* terminology. Where a country is indicated in square brackets following the definition, the definition shall apply only in the country indicated. Terms not defined in Section A2.1 shall have the ordinary accepted meaning for the intended context.

Adjusted Shear Resistance. In *Type II shear walls*, the unadjusted shear resistance multiplied by

the shear resistance adjustment factor.

Allowable Strength. Nominal strength divided by the safety factor R_n/Ω . [USA and Mexico]

Applicable Building Code. The building code under which the building is designed.

Approved. Acceptable to the authority having jurisdiction.

ASD (Allowable Strength Design). Method of proportioning structural components such that the allowable strength equals or exceeds the required strength of the component under the action of the ASD load combinations. [USA and Mexico]

ASD Load Combination. Load combination in the applicable building code intended for allowable strength design (allowable stress design). [USA and Mexico]

Authority Having Jurisdiction. An organization, political subdivision, office, or individual charged with the responsibility of administering and enforcing the provisions of the applicable building code.

Available Strength. Design strength or allowable strength, as appropriate. [USA and Mexico]

Base Steel Thickness. The thickness of bare steel exclusive of all coatings.

Bearing Stiffener. Additional material that is attached to the web to strengthen the member against web crippling. Also called a web stiffener.

Blocking. C-shaped member, break shape, flat strap material, or component assemblies attached to structural members, flat strap or sheathing panels to transfer shear forces or stabilize members.

Blocking, Panel. Blocking that transmits shear between the panels of a shear wall or diaphragm.

Blocking, Stud. Blocking that provides torsional restraint to the studs in a shear wall.

Bracing. Structural elements that are installed to provide restraint or support (or both) to other structural members or nonstructural members so that the complete assembly forms a stable structure.

Ceiling Joist. A horizontal structural member that supports ceiling components and which may be subject to attic loads.

Chord. Member of a shear wall, strap braced wall or diaphragm that forms the perimeter, interior opening, discontinuity or re-entrant corner.

Chord Member. A structural member that forms the top or bottom component of a truss.

Chord Splice. The connection region between two truss chord members where there is no change in slope.

Chord Stud. Axial load-bearing studs located at the ends of Type I shear walls or Type II shear wall segments or strap braced walls.

Clip Angle. An L-shaped short piece of steel typically used for connections.

Cold-Formed Sheet Steel. Sheet steel or strip steel that is manufactured by (1) press braking blanks sheared from sheets or cut length of coils or plates, or by (2) continuous roll forming of cold- or hot-rolled coils of sheet steel; both forming operations are performed at ambient room temperature, that is, without any addition of heat such as would be required for hot forming.

Cold-Formed Steel. See *Cold-Formed Sheet Steel*.

Collector. Also known as a drag strut, a member parallel to the applied load that serves to transfer forces between diaphragms and members of the lateral force-resisting system or distributes forces within the diaphragm.

Component. See *Structural Component*.

Component Assembly. A fabricated assemblage which consists primarily of cold-formed steel

- structural members* that is manufactured by the *component manufacturer*.
- Component Manufacturer*. The individual or organization responsible for the manufacturing of *component assemblies* for the project. Also referred to as *truss manufacturer* on projects involving *trusses*, but hereinafter will be referred to as *component manufacturer*.
- Connection*. Combination of structural elements and joints used to transmit forces between two or more members.
- Connector*. A device used to transmit forces between *cold-formed steel structural members*, or between a *cold-formed steel structural member* and another structural element.
- Contractor*. *Owner* of the building, or the person that contracts with the *owner*, who constructs or manages the construction of the building in accordance with the *construction documents*. Also referred to as *owner's representative* for construction, but hereinafter will be referred to as contractor.
- Construction Documents*. Written, graphic and pictorial documents prepared or assembled for describing the design (including the structural system), location and physical characteristics of the elements of a building necessary to obtain a building permit and construct a building.
- Cripple Stud*. A *stud* that is placed between a *header* and a window or door head *track*, a *header* and wall top *track*, or a window sill and a bottom *track* to provide a backing to attach finishing and sheathing material.
- C-Shape*. A cold-formed steel shape used for *structural members* and *nonstructural members* consisting of a *web*, two (2) *flanges* and two (2) *lips* (*edge stiffeners*).
- Curtain Wall*. A wall that transfers transverse (out-of-plane) *loads* and is limited to a superimposed vertical *load*, exclusive of sheathing materials, of not more than 100 lb/ft (1.46 kN/m), or a superimposed vertical *load* of not more than 200 lbs (0.890 kN).
- Deflection Track*. A *track* manufactured with extended *flanges* and used at the top of a wall to provide for vertical movement of the structure, independent of the wall *stud*.
- Design Load*. Applied *load* determined in accordance with either *LRFD load combinations* or *ASD load combinations*, whichever is applicable. [USA and Mexico]
- Design Strength*. *Resistance factor* multiplied by the *nominal strength*. [USA and Mexico]
- Design Thickness*. The steel thickness used in design.
- Designation Thickness*. The minimum *base steel thickness* expressed in *mils* and rounded to a whole number.
- Diaphragm*. Roof, floor or other membrane or *bracing* system that transfers in-plane forces to the *lateral force-resisting system*.
- Eave Overhang*. The horizontal projection of the roof measured from the outside face of exterior wall framing to the outside edge of the roof.
- Edge Stiffener*. See *Lip*.
- Factored Load*. Product of a *load factor* and the *nominal load* [*specified load*].
- Factored Resistance*. Product of *nominal resistance* and appropriate *resistance factor*. [Canada]
- Fiberboard*. A fibrous, homogeneous panel made from lignocellulosic fibers (usually wood or cane) and having a density of less than 31 pounds per cubic foot (pcf) (497 kg/m³) but more than 10 pcf (160 kg/m³).
- Flange*. For a *C-shape*, *U-shape* or *track*, that portion of the *structural member* or *nonstructural member* that is perpendicular to the *web*. For a furring channel, that portion of the *structural member* or *nonstructural member* that connects the *webs*.

- Floor Joist.* A horizontal *structural member* that supports floor *loads* and superimposed vertical *loads*.
- Girt.* Horizontal *structural member* that supports wall panels and is primarily subjected to bending under horizontal *loads*, such as wind *load*.
- Grade.* The designation of the minimum *yield strength*.
- Gusset Plate.* A *structural member* used to facilitate the *connection* of *truss chord* or *web members* at a *heel*, *ridge*, other pitch break, or *panel point*.
- Hat-Shape.* A singly symmetric shape consisting of at least two vertical *webs* and a horizontal stiffened *flange* which is used as a *chord member* in a *truss*.
- Header.* A horizontal *structural member* used over floor, roof or wall openings to transfer *loads* around the opening to supporting *structural members*.
- Heel.* The *connection* region between the top and bottom *truss chords* of a non-parallel *chord truss*.
- Hold-Down (Tie-Down).* A device used to resist overturning forces in a *shear wall* or *strap braced wall*, or uplift forces in a *cold-formed steel structural member*.
- Inspection.* When used in conjunction with *quality control* and *quality assurance*, it shall mean the systematic examination and review of the work for compliance with the appropriate documents, with appropriate subsequent documentation.
- Installation Drawings.* Drawings that show the location and installation of the *cold-formed steel* structural framing. Also referred to as *truss* placement diagram for *truss* construction.
- Installer.* Party responsible for the installation of *cold-formed steel light-frame construction*.
- Jack Stud.* A *stud* that does not span the full height of the wall and provides bearing for *headers*.
- Joist.* A *structural member* primarily used in floor and ceiling framing.
- King Stud.* A *stud*, adjacent to a *jack stud*, that spans the full height of the wall and supports vertical and lateral *loads*.
- Lateral Force-Resisting System.* The structural elements and *connections* required to resist racking and overturning due to wind forces or seismic forces, or other predominantly horizontal forces, or combination thereof, imposed upon the structure in accordance with the *applicable building code*.
- Light-Frame Construction.* Construction where the vertical and horizontal structural elements are primarily formed by a system of repetitive *cold-formed steel* or wood framing members.
- Limit States.* Those conditions in which a *structural member* ceases to fulfill the function for which it was designed. Those states concerning safety are called the ultimate limit states. The ultimate limit state for strength is the maximum *load-carrying capacity*. Limit states that restrict the intended use of a member for reasons other than safety, such as deflection and vibration, are called serviceability limit states. [Canada]
- Lip.* That part of a *structural* or *nonstructural member* that extends from the *flange* as a stiffening element.
- Load.* Force or other action that results from the weight of building materials, occupants and their possessions, environmental effects, differential movement, or restrained dimensional changes.
- Load Effect.* Forces, stresses, and deformations produced in a *structural component* by the applied *loads*.
- Load Factor.* Factor that accounts for deviations of the actual *load* from the *nominal load*, for

- uncertainties in the analysis that transforms the *load* into a *load effect*, and for the probability that more than one extreme *load* will occur simultaneously. [USA and Mexico]
- LRFD (Load and Resistance Factor Design)*. Method of proportioning *structural components* such that the *design strength* equals or exceeds the *required strength* of the *component* under the action of the *LRFD load combinations*. [USA and Mexico]
- LRFD Load Combination*. Load combination in the *applicable building code* intended for strength design (*Load and Resistance Factor Design*). [USA and Mexico]
- LSD (Limit States Design)*. Method of proportioning *structural components* (members, connectors, connecting elements and assemblages) such that no applicable *limit state* is exceeded when the structure is subjected to all appropriate *load combinations*. [Canada]
- Mean Roof Height*. The average of the roof eave height and the height to the highest point on the roof surface, except that eave height shall be used for roof angles less than or equal to 10 degrees (0.18 rad).
- Mil*. A unit of measurement equal to 1/1000 inch.
- Multiple Span*. The *span* made by a continuous member having intermediate supports.
- Nominal Load*. Magnitude of the *load* specified by the *applicable building code*. [USA and Mexico]
- Nominal Resistance (Resistance)*. Capacity of a structure or *component* to resist the effects of *loads*, determined in accordance with this Standard using specified material strengths and dimensions. [Canada]
- Nominal Strength*. Strength of a structure or *component* (without the *resistance factor* or *safety factor* applied) to resist the *load effects*, as determined in accordance with this Standard. [USA and Mexico]
- Nonstructural Member*. A member in a steel-framed system that is not a part of the gravity *load-resisting system*, *lateral force-resisting system* or building envelope.
- Owner*. The individual or entity organizing and financing the design and construction of the project.
- Panel Point*. The *connection* region between a *web member* and *chord member* in a *truss*.
- Pitch Break*. The *connection* region between two *truss chord members* where there is a change in slope, excluding the *heel*.
- Plans*. Also referred to as construction drawings. Drawings prepared by the building designer for the *owner* of the project. These drawings include but are not limited to floor plans, framing plans, elevations, sections, details and schedules as necessary to define the desired construction.
- Plan Aspect Ratio*. The ratio of the length (longer dimension) to the width (shorter dimension) of the building.
- Punchout*. A hole made during the manufacturing process in the *web* of a steel framing member.
- Purlin*. Horizontal *structural member* that supports roof deck and is primarily subjected to bending under vertical *loads* such as snow, wind, or dead *loads*.
- Quality Assurance*. Monitoring and *inspection* tasks performed by a *registered design professional*, firm or *approved agency* other than the *component manufacturer* or *installer* to ensure that the material provided and work performed by the *component manufacturer* and *installer* meet the requirements of the *approved construction documents* and referenced standards. *Quality assurance* includes those tasks designated “special inspection” by the *applicable building code*.

- Quality Assurance Inspector.* Individual or agency designated to provide *quality assurance inspection* for the work being performed.
- Quality Control.* Controls and *inspections* implemented by the *component manufacturer* or *installer* to confirm that the material provided and work performed meet the requirements of the *approved construction documents* and referenced standards.
- Quality Control Inspector.* Individual or agency designated to perform *quality control inspection* tasks for the work being performed.
- Quality Control Program.* Program in which the *component manufacturer* or *installer*, as applicable, maintains detailed assembly or installation and *inspection* procedures to ensure conformance with the *approved installation drawings, plans, specifications* and referenced standards.
- Rake Overhang.* The horizontal projection of the roof measured from the outside face of a gable endwall to the outside edge of the roof.
- Rational Engineering Analysis.* Analysis based on theory that is appropriate for the situation, any relevant test data, if available, and sound engineering judgment.
- Registered Design Professional.* Architect or engineer who is licensed to practice their respective design profession as defined by the legal requirements of the jurisdiction in which the building is to be constructed.
- Repetitive Framing.* A framing system where the wall, floor and roof *structural members* are spaced no greater than 24 inches (610 mm) on center. Larger spaces are permitted at openings where the structural *loads* are transferred to headers or lintels and supporting *studs, joists* or *rafters*.
- Required Strength.* Forces, stresses, and deformations produced in a *structural component*, determined by either structural analysis, for the *LRFD* or *ASD load combinations*, as appropriate, or as specified by this Standard. [USA and Mexico]
- Resistance Factor (ϕ).* Factor that accounts for unavoidable deviations of the actual strength from the *nominal strength* [*nominal resistance*] and for the manner and consequences of failure.
- Ridge.* The horizontal line formed by the joining of the top edges of two upward sloping roof surfaces.
- Rim Track.* A horizontal *structural member* that is connected to the end of a *floor joist*.
- Risk Category.* A categorization of buildings and other structures for determination of flood, wind, snow, ice, and earthquake loads based on the risk associated with unacceptable performance.
- Roof Rafter.* A horizontal or sloped, *structural member* that supports roof *loads*.
- Safety Factor (Ω).* Factor that accounts for the desired level of safety, including deviations of the actual *load* from the *nominal load* and uncertainties in the analysis that transforms the *load* into a *load effect*, in determining the *nominal strength* and for the manner and consequences of failure. [USA and Mexico]
- Seismic Design Category (SDC).* A classification assigned by the *applicable building code* to a structure based upon its *risk category* and the severity of the design earthquake ground motion at the site.
- Seismic Force-Resisting System.* That part of the structural system that has been selected in the design to provide energy dissipation and the required resistance to seismic forces prescribed in the *applicable building code*.
- Shear Wall.* A wall with *structural sheathing* attached to *cold-formed steel structural members* and

- designed to primarily resist lateral forces parallel to the wall.
- Shop Drawings.* Drawings for the production of individual *component assemblies* for the project.
- Single Span.* The *span* made by one continuous *structural member* without any intermediate supports.
- Span.* The clear horizontal distance between bearing supports.
- Specifications.* Written instructions, which, with the *plans*, define the materials, standards, design of the products, and workmanship expected on a construction project.
- Specified Load.* Magnitude of the *load* specified by the *applicable building code*, not including *load factors*. [Canada]
- Static Load.* A *load* or series of *loads* that are supported by or are applied to a structure so gradually that forces caused by change in momentum of the *load* and structural elements can be neglected and all parts of the system at any instant are essentially in equilibrium.
- Steel Sheet Sheathing.* A panel of thin flat steel sheet.
- Strap.* Flat or coiled sheet steel material typically used for *bracing* or *blocking*, which transfers *loads* by tension or shear.
- Strap Braced Wall.* A wall with *strap bracing* attached to *cold-formed steel structural members* and designed to primarily resist lateral forces parallel to the wall.
- Strap Bracing.* Steel *straps* applied diagonally to form a vertical *truss* that forms part of the *lateral force-resisting system*.
- Structural Component.* Member, *connector*, connecting element or assemblage.
- Structural Member.* A member that resists *design loads* [*factored loads*], as required by the *applicable building code*, except when defined as a *nonstructural member*.
- Structural Sheathing.* The structural sheathing that is capable of distributing *loads*, *bracing members*, and providing additional stability that strengthens the assembly.
- Stud.* A vertical *structural member* or *nonstructural member* in a wall system or assembly.
- Track.* A *structural member* or *nonstructural member* consisting of only a *web* and two (2) *flanges*.
Track web depth measurements are taken to the inside of the *flanges*.
- Truss.* A coplanar system of *structural members* joined together at their ends typically to construct a series of triangles that form a stable beam-like framework.
- Truss Design Drawing.* Written, graphic and pictorial depiction of an individual *truss*.
- Truss Design Engineer.* Person who is licensed to practice engineering as defined by the legal requirements of the jurisdiction in which the building is to be constructed and who supervises the preparation of the *truss design drawings*.
- Truss Designer.* Person responsible for the preparation of the *truss design drawings*.
- Truss Manufacturer.* An individual or organization engaged in the manufacturing of site-built or in-plant *trusses*.
- Truss Member.* A *chord member* or *web member* of a *truss*.
- Type I Shear Wall.* Wall designed to resist in-plane lateral forces that is fully sheathed and that is provided with *hold-downs* at each end of the wall segment.
- Type II Shear Wall.* Wall designed to resist in-plane lateral forces that is sheathed with *wood structural panels* or *steel sheet sheathing* that contains openings, but which has not been specifically designed and detailed for force transfer around wall openings. *Hold-downs* for *Type II shear walls* are only required at the ends of the wall.
- Type II Shear Wall Segment.* Section of *shear wall* (within a *Type II shear wall*) with full-height sheathing (i.e., with no openings) and which meets specific aspect ratio limits.

Wall Pier. A section of a *Type I shear wall* adjacent to an opening and equal in height to the opening, which is designed to resist lateral forces in the plane of the wall.

Web. That portion of a *structural member* or *nonstructural member* that connects the *flanges*.

Web Member. A *structural member* in a *truss* that is connected to the top and bottom *chords*, but is not a *chord member*.

Wind Exposure. Wind exposure in accordance with the *applicable building code*.

Wood Structural Panel. A panel manufactured from veneers, wood strands or wafers or a combination of veneer and wood strands or wafers bonded together with waterproof synthetic resins or other suitable bonding systems.

Yield Strength. Stress at which a material exhibits a specified limiting deviation from the proportionality of stress to strain as defined by ASTM.

Z-Shape. A point-symmetric or non-symmetric section that is used as a *chord member* in a *truss*.

A3 Material

A3.1 *Structural members* utilized in *cold-formed steel light-frame construction* shall be cold-formed to shape from sheet steel complying with the requirements of ASTM A1003/A1003M, subject to the following limitations:

(a) Type H (high ductility): No limitations.

(b) Type L (low ductility): Limited to *purlins*, *girts* and *curtain wall studs*. Additional country-specific limitations for *curtain wall studs* are provided in Section A2.3.5 of AISI S100 [CSA S136].

A3.2 In Canada, *structural members* are permitted to be cold-formed to shape from sheet steel complying with the requirements of ASTM A653/A653M Type SS or ASTM A792/A792M Type SS.

A4 Corrosion Protection

A4.1 *Structural members* utilized in *cold-formed steel light-frame construction* shall have a protective coating as specified in Table A4-1.

Table A4-1
Coating Designations

Coating Classification	Coating Designator	Minimum Coating Requirements			
		Zinc Coated ^A oz/ft ² (g/m ²)	Zinc Iron ^B oz/ft ² (g/m ²)	55% Al-Zinc ^C oz/ft ² (g/m ²)	Zinc-5% ^D oz/ft ² (g/m ²)
Metallic Coated	CP 60	G60 [Z180]	A60 [ZF180]	AZ50 [AZM150]	CF30 [ZGF90]
	CP 90	G90 [Z275]	Not Applicable	AZ50 [AZM150]	CF45 [ZGF135]
Painted Metallic	PM	The metallic coated substrate shall meet the requirements of metallic coated. In addition, the paint film shall have a minimum thickness of 0.5 mil per side (primer plus topcoat) with a minimum primer thickness of 0.1 mil per side. ^E			

^A Zinc-coated steel sheet as described in ASTM A653/A653M.

^B Zinc-iron alloy-coated steel sheet as described in ASTM A653/A653M.

^C 55% Aluminum-zinc alloy-coated steel sheet as described in ASTM A792/A792M.

^D Zinc-5% aluminum alloy-coated steel sheet as described in ASTM A875/A875M.

^E In accordance with the requirements of ASTM A1003/A1003M.

A4.1.1 In Canada, *structural members* utilized in *cold-formed steel light-frame construction* shall have a metallic coating of G60 [Z180] complying with the requirements of ASTM A653/A653M or AZ50 [AZM150] complying with the requirements of ASTM A792/A792M.

A4.2 Additional corrosion protection shall not be required on edges of metallic-coated steel framing members, where shop or field cut, punched or drilled.

A4.3 Unless additional corrosion protection is provided, framing members shall be located within the building envelope and shielded from direct contact with moisture from the ground or the exterior climate.

A4.4 Dissimilar metals shall not be used in direct contact with *cold-formed steel* framing members unless *approved* for that application.

A4.5 *Cold-formed steel* framing members shall not be embedded in concrete unless *approved* for that application.

A4.6 Fasteners shall have a corrosion-resistant treatment, or be manufactured from material not susceptible to corrosion.

A5 Products

A5.1 Base Steel Thickness

The material thickness of framing members, in their end-use, shall meet or exceed the minimum *base steel thickness* values given in the *approved construction documents*. In no case shall the minimum *base steel thickness* be less than 95% of the *design thickness*.

A5.2 Minimum Flange Width

Where intended for sheathing attachment, *C-shape* members shall have a minimum *flange* width of 1-1/4 inch (31.8 mm). For *track* members, the minimum *flange* width shall be 3/4 inch (19.1 mm).

A5.3 Product Designator

A5.3.1 A four-part product designator that identifies the size (both *web* depth and *flange* width), type, and thickness shall be used for reference to *structural members*. The product designator as described (i.e., based on U.S. Customary units) shall be used for either U.S. Customary or SI Metric units. The product designator shall consist of the following sequential codes:

(a) A three- or four-digit numeral indicating member *web* depth in 1/100 inch.

(b) A letter indicating member type, in accordance with the following:

S = *Stud* or *joist* framing member which has *lips*

T = *Track* section

U = Channel or *stud* framing section which does not have *lips*

F = Furring channels

L = Angle or L-*header*

(c) A three-digit numeral indicating *flange* width in 1/100 inch, followed by a dash.

(d) A two- or three-digit numeral indicating *designation thickness*.

A5.3.2 The material *grade* used in design shall be identified on the *construction documents* and when ordering the material.

A5.4 Manufacturing Tolerances

Structural members utilized in *cold-formed steel light-frame construction* shall comply with the manufacturing tolerances listed in Table A5-1, as illustrated in Figure A5-1. All measurements shall be taken not less than 1 ft (305 mm) from the end of the member.

Table A5-1
Manufacturing Tolerances for Structural Members

Dimension ¹	Item Checked	Studs, in. (mm)	Tracks, in. (mm)
A	Length	+3/32 (2.38)	+ 1/2 (12.7)
		-3/32 (2.38)	-1/4 (6.35)
B ²	Web Depth	+1/32 (0.79)	+1/32 (0.79)
		-1/32 (0.79)	+1/8 (3.18)
C	Flare	+1/16 (1.59)	+0 (0)
	Overbend	-1/16 (1.59)	-3/32 (2.38)
D	Hole Center Width	+1/16 (1.59)	NA
		-1/16 (1.59)	NA
E	Hole Center Length	+1/4 (6.35)	NA
		-1/4 (6.35)	NA
F	Crown	+1/16 (1.59)	+1/16 (1.59)
		-1/16 (1.59)	-1/16 (1.59)
G ³	Camber	1/8 per 10 ft (3.13 per 3 m)	1/32 per ft (2.60 per m) 1/2 max (12.7)
H ³	Bow	1/8 per 10 ft (3.13 per 3 m)	1/32 per ft (2.60 per m)
			1/2 max (12.7)
I	Twist	1/32 per ft (2.60 per m)	1/32 per ft (2.60 per m)
		1/2 max (12.7)	1/2 max (12.7)
J	Flange Width	+1/8 (3.18)	+1/4 (6.35)
		-1/16 (1.59)	-1/16 (1.59)
K	Stiffening Lip Length	+1/8 (3.18)	NA
		-1/32 (0.79)	

¹ All measurements are taken not less than 1 ft (305 mm) from the end.

² Outside dimension for *stud*; inside for *track*.

³ 1/8 inch per 10 feet represents L/960 maximum for overall camber and bow. Thus, a 20-foot-long member has 1/4 inch permissible maximum; a 5-foot-long member has 1/16-inch permissible maximum.

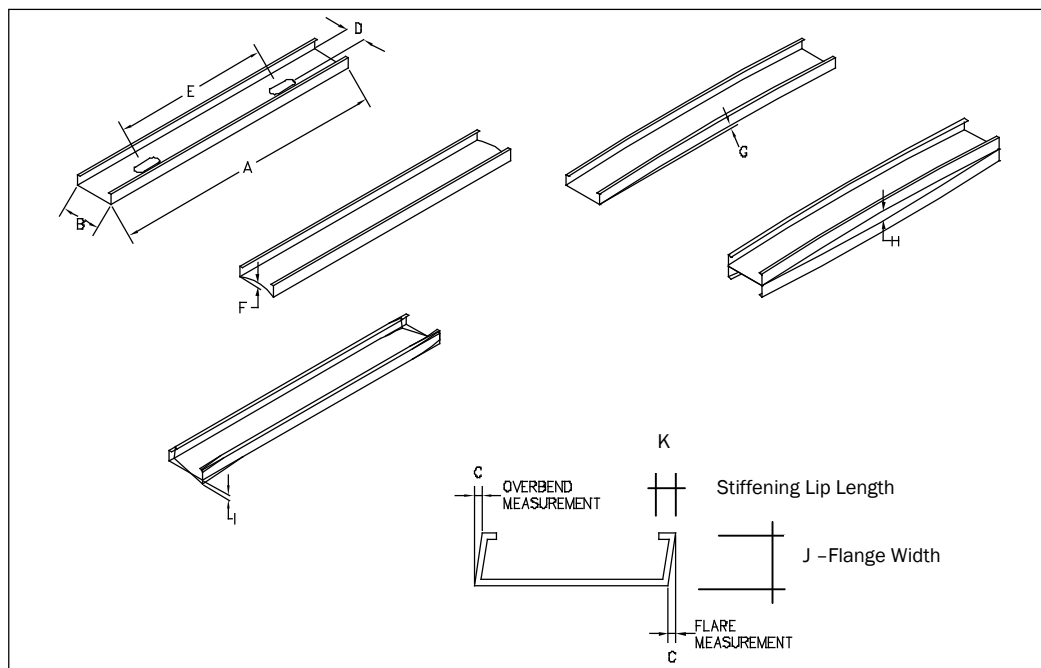

Figure A5-1 Manufacturing Tolerances for Structural Members

A5.5 Product Identification

Framing members used in *cold-formed steel light-frame construction* shall be identified in accordance with the requirements of this section.

A5.5.1 Identification of Groups of Like Members

Groups of like members shall be marked with a label, or a tag attached thereto. Marking shall include the roll-former's identification (name, logo, or initials), length, quantity, and roll-former's member designator including member depth, *flange* size, and minimum steel thickness in mils or inches exclusive of protective coating.

A5.5.2 Identification of Individual Framing Members

A5.5.2.1 In the United States and Mexico, in addition to the marking referenced in A5.5.1, individual framing members shall have a legible label, stencil, or embossment, at a maximum distance of 96 in. (2440 mm) on center, on the member, with the following minimum information:

- (a) The rollformer's identification (i.e., name, logo, or initials).
- (b) The minimum steel thickness, in mils or inches, exclusive of protective coating.
- (c) The minimum *yield strength* in kips per square inch [megapascals].
- (d) The appropriate protective coating designator in accordance with Section A4.

A5.5.2.2 In Canada, in addition to the marking referenced in A5.5.1, individual framing members shall have a legible label, stencil, or embossment, at a maximum distance of 96 in. (2440 mm) on center, on the member, with the following minimum information:

- (a) The manufacturer's identification (name, logo, or initials); and
- (b) The minimum steel thickness (in mils, inches or millimeters) exclusive of protective coatings.

A6 Reference Documents

The following documents or portions thereof are referenced within this Standard and shall be considered as part of the requirements of this document.

1. American Society of Civil Engineers, Reston, VA
ASCE 7-10 Including Supplement No. 1, *Minimum Design Loads for Buildings and Other Structures*.
2. American Iron and Steel Institute, Washington, DC
AISI S100-12, *North American Specification for the Design of Cold-Formed Steel Structural Members*
AISI S202-15, *Code of Standard Practice for Cold-Formed Steel Structural Framing*
AISI S901-13, *Rotational-Lateral Stiffness Test Method for Beam-to-Panel Assemblies*
AISI S902-13, *Stub-Column Test Method for Effective Area of Cold-Formed Steel Columns*
AISI S903-13, *Standard Methods for Determination of Uniform and Local Ductility*
AISI S904-13, *Standard Test Methods for Determining the Tensile and Shear Strength of Screws*
AISI S905-13, *Test Standard for Cold-Formed Steel Connections*
AISI S907-13, *Test Standard for Cantilever Test Method for Cold-Formed Steel Diaphragms*
AISI S909-13, *Standard Test Method for Determining the Web Crippling Strength of Cold-Formed*

Steel Beams

AISI S910-13, *Test Method for Distortional Buckling of Cold-Formed Steel Hat-Shaped Compression Members*

AISI S911-13, *Method for Flexural Testing of Cold-Formed Steel Hat-Shaped Beams*

AISI S913-13, *Test Standard for Hold-Downs Attached to Cold-Formed Steel Structural Framing*

AISI S914-15, *Test Standard for Joist Connectors Attached to Cold-Formed Steel Structural Framing*

AISI S915-15, *Test Standard for Through-The-Web Punchout Cold-Formed Steel Wall Stud Bridging Connectors*

3. ASTM International, West Conshohocken, PA

ASTM A653/A653M-15, *Standard Specification for Steel Sheet, Zinc-Coated (Galvanized) or Zinc-Iron Alloy-Coated (Galvannealed) by the Hot-Dip Process*

ASTM A792/A792M-10, *Standard Specification for Steel Sheet, 55% Aluminum-Zinc Alloy-Coated by the Hot-Dip Process*

ASTM A875/A875M-13, *Standard Specification for Steel Sheet, Zinc-5% Aluminum Alloy-Coated by the Hot-Dip Process*

ASTM A1003/A1003M-15, *Standard Specification for Steel Sheet, Carbon, Metallic- and Nonmetallic-Coated for Cold-Formed Framing Members*

ASTM C208-12, *Standard Specification for Cellulosic Fiber Insulating Board*

ASTM C954-15, *Standard Specification for Steel Drill Screws for the Application of Gypsum Panel Products or Metal Plaster Bases to Steel Studs From 0.033 in. (0.84 mm) to 0.112 in. (2.84 mm) in Thickness*

ASTM C1002-14, *Standard Specification for Steel Self-Piercing Tapping Screws for the Application of Gypsum Panel Products or Metal Plaster Bases to Wood Studs or Steel Studs*

ASTM C1396/C1396M-14a, *Standard Specification for Gypsum Board*

ASTM C1513-13, *Standard Specification for Steel Tapping Screws for Cold-Formed Steel Framing Connections*

ASTM E455-11, *Standard Method for Static Load Testing of Framed Floor or Roof Diaphragm Constructions for Buildings*

ASTM E2126-11, *Standard Test Methods for Cyclic (Reversed) Load Test for Shear Resistance of Vertical Elements of the Lateral Force Resisting Systems for Buildings*

4. American Welding Society, Miami, FL

AWS B5.1, *Specification for the Qualification of Welding Inspectors*, 2003 Edition

AWS D1.3, *Structural Welding Code-Sheet Steel*, 2008 Edition

5. CSA Group, Mississauga, Ontario, Canada

CSA O325-07 (R2012), *Construction Sheathing*

CAN/CSA-S136-12, *North American Specification for the Design of Cold-Formed Steel Structural Members*

CSA O121-08 (R2013), *Douglas Fir Plywood*

CSA O151-09 (R2014), *Canadian Softwood Plywood*

CSA O325-07(R2012), *Construction Sheathing*

CSA O437-93 (R2011), *Standards on OSB and Waferboard*

6. Department of Commerce Voluntary Product Standard, administered by NIST, Gaithersburg, MD

DOC PS 1-09, *Structural Plywood*

DOC PS 2-10, *Performance Standard for Wood-Based Structural-Use Panels*

7. National Research Council of Canada, Ottawa, Ontario, Canada

NBCC 2010, *National Building Code of Canada*, 2010 Edition

B. DESIGN

B1 General

The provisions in Section B1 shall be used in conjunction with the requirements in Sections B2 through B5, as applicable.

B1.1 Loads and Load Combinations

Buildings or other structures and all parts therein shall be designed in accordance with the *applicable building code* to support all *loads* that are expected during its life. In the absence of an *applicable building code*, the *loads*, forces, and combinations of *loads* shall be in accordance with accepted engineering practice for the location under consideration as specified by the applicable sections of ASCE 7, *Minimum Design Loads for Buildings and Other Structures* in the United States and Mexico, or the *National Building Code of Canada* in Canada.

B1.1.1 Application of Live Load Reduction on Wall Studs

For the purpose of calculating the design axial *load* on a wall using floor live *load* reduction requirements in accordance with the *applicable building code*, the tributary area of the wall shall be limited to the floor area assigned to the individual wall framing members.

B1.1.2 Application of Wind Loads on Wall Studs in the United States and Mexico

In the United States and Mexico, the design of the wall *studs* shall be based on the following design wind loads:

- (a) Combined bending and axial *load effect* based on Main Wind Force-Resisting System (MWFRS) wind *loads*.
- (b) Bending *load effect* based on Components and Cladding (C&C) wind *loads*.
- (c) Deflection limits based on 42% of Components and Cladding (C&C) wind *loads* with no axial *loads*.

B1.2 Design Basis

The proportioning, designing and detailing of *cold-formed steel light-frame lateral force-resisting systems, trusses, structural members, connections and connectors* shall be in accordance with AISI S100 [CSA S136], and the reference documents except as modified or supplemented by the requirements of this Standard.

B1.2.1 Floor Joists, Ceiling Joists and Roof Rafters

B1.2.1.1 *Floor joists, ceiling joists and roof rafters* shall be designed either on the basis of discretely braced design or on the basis of continuously braced design, in accordance with the following:

- (a) Discretely Braced Design. Floor and roof assemblies using discretely braced design shall be designed neglecting the structural *bracing* and composite-action contribution of attached sheathing or deck. Discretely braced design shall include assemblies where the sheathing or deck is not attached directly to *structural members*.
- (b) Continuously Braced Design. Unless noted otherwise in Section B2 or B4, the continuously braced design requirements of this Standard shall be limited to

floor joists, ceiling joists and roof rafters that comply with all of the following conditions:

- (1) Maximum *web* depth = 14 inches (356 mm)
- (2) Maximum *design thickness* = 0.1242 inches (3.155 mm)
- (3) Minimum design *yield strength*, $F_y = 33$ ksi (230 MPa)
- (4) Maximum design *yield strength*, $F_y = 50$ ksi (345 MPa)

B1.2.1.2 Where continuously braced design is used, the *construction documents* shall identify the sheathing or deck as a structural element.

B1.2.1.3 A *web* with one or more holes shall be designed in accordance with AISI S100 [CSA S136], or reinforced in accordance with an *approved* design or as specified by a *registered design professional*.

B1.2.2 Wall Studs

B1.2.2.1 Wall *studs* shall be designed either on the basis of all steel design or on the basis of sheathing braced design, in accordance with the following:

- (a) All Steel Design. Wall *stud* assemblies using all steel design shall be designed neglecting the structural *bracing* and composite-action contribution of the attached sheathings.
- (b) Sheathing Braced Design. Wall *stud* assemblies using sheathing braced design shall have sheathing attached to both *flanges* of the wall *stud* or sheathing attached to the one *flange* and discrete bracing to the other *flange*. The *stud* shall be connected to the bottom and top *track* or other horizontal member(s) of the wall to provide lateral and torsional support to the wall *stud* in the plane of the wall. Wall *studs* with sheathing attached to both sides that is not identical shall be designed based on the assumption that the weaker of the two sheathings is attached to both sides.

B1.2.2.2 When sheathing braced design is used, the *construction documents* shall identify the sheathing as a structural element.

B1.2.2.3 For *curtain wall studs*, the combination of sheathing attached to one side of the wall *stud* and discrete bracing for the other *flange* is permitted. The spacing of discrete bracing shall be no greater than 8 ft (2.44 m) on center. For design, the *nominal flexural strength [resistance]* shall be determined by AISI S100 Section C3.1. When the compression *flange* has sheathing attached, AISI S100 Section C3.1.1 is permitted. When the compression *flange* does not have sheathing attached, AISI S100 Section C3.1.2 shall apply. In both cases, AISI S100 Section C3.1.4 for distortional buckling shall also be considered.

B1.2.2.4 In the United States and Mexico, when sheathing braced design is used, the wall *studs* shall also be evaluated without the sheathing *bracing* for the following *load* combination:

$$1.2D + (0.5L \text{ or } 0.2S) + 0.2W \quad (\text{Eq. B1.2.2-1})$$

where

D = Dead *load*

L = Live *load*

S = Snow *load*

W = Wind *load*

B1.2.2.5 In Canada, the provisions for sheathing braced design shall be in accordance

with a theory, tests, or *rational engineering analysis* and shall comply with Chapter C of AISI S100 [CSA S136], as applicable.

B1.2.2.6 A *web* with one or more holes shall be designed in accordance with AISI S100 [CSA S136].

B1.2.3 In-Line Framing

B1.2.3.1 Each *joist, rafter, truss, and structural wall stud* (above or below) shall be aligned vertically in accordance with the limits depicted in Figure B1.2.3-1.

B1.2.3.2 The alignment tolerance shall not be required to be met when a structural load distribution member is specified in accordance with the *approved construction documents*.

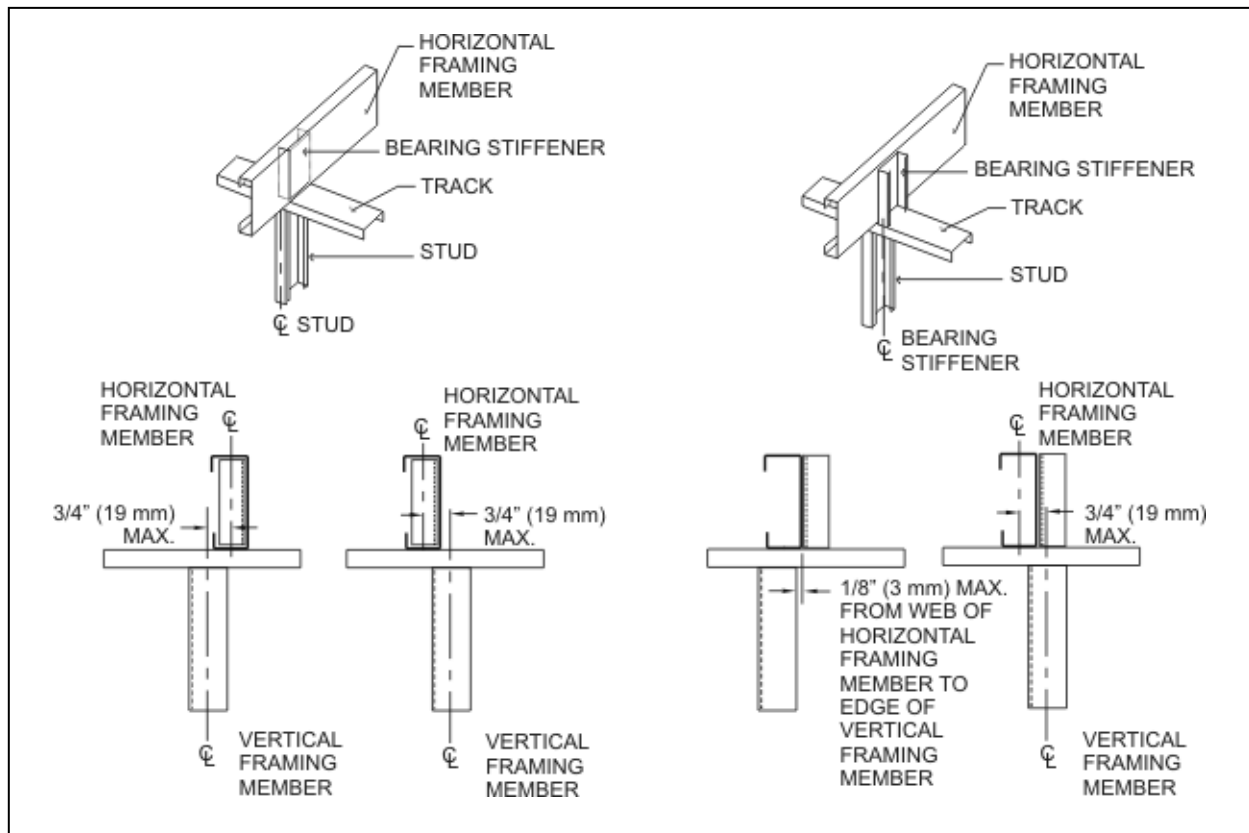

Figure B1.2.3-1 In-Line Framing

B1.2.4 Sheathing Span Capacity

B1.2.4.1 *Floor joist* and *floor truss* spacing shall be limited by the span capacity of the *floor structural sheathing* material.

B1.2.4.2 *Wall stud* spacing shall be limited by the span capacity of the *wall structural sheathing* material.

B1.2.4.3 The spacing of roof and ceiling framing members shall be limited by the span capacity of the ceiling or roof *structural sheathing* material.

B1.2.5 Load Path

A continuous *load* path to the foundation shall be provided for the uplift, shear, and

compression forces due to lateral wind forces, seismic forces, or other predominantly horizontal forces, or combinations thereof, imposed upon the structure in accordance with the *applicable building code*. Elements resisting forces contributed by multiple stories shall be designed for the sum of forces contributed by each story in conformance to *applicable building code*.

B1.2.6 Principles of Mechanics

Where *cold-formed steel structural members and connections* are not required to be designed in accordance with the additional provisions of Section A1.3, the provisions of this section are permitted for *lateral force-resisting systems*.

B1.2.6.1 The shear resistance of *shear walls, strap braced walls and diaphragms* is permitted to be determined by principles of mechanics using values of fastener strength, sheathing shear resistance, and *strap strength*, as applicable.

B1.2.6.2 When determined by the principles of mechanics, the *nominal strength* [*nominal resistance*] defines the maximum resistance that the *diaphragm, shear wall, or strap braced wall* is capable of developing.

B1.2.6.3 *Required strength* [effect of *factored loads*] shall be determined in accordance with the force requirements in the *applicable building code*.

B1.2.6.4 When determined by the principles of mechanics, values for systems defined in this Standard shall be scaled to the values in this Standard.

B1.3 Built-Up Section Design

Built-up sections shall be evaluated in accordance with Section D1 of AISI S100 [CSA S136] and the additional requirements of Sections B1.3.1 and B1.3.2, as applicable.

B1.3.1 For either all steel design or sheathing braced design, the *available strength* [*factored resistance*] of built-up sections shall be determined in accordance with Section D1.2 of AISI S100 [CSA S136].

Exception: Where a built-up axial *load bearing* section comprised of two *studs* oriented back-to-back forming an I-shaped cross-section is seated in a *track* in accordance with the requirements of Section C3.4.3 and the top and bottom end bearing detail of the *studs* consists of support by steel or concrete components with adequate strength and stiffness to preclude relative end slip of the two built-up *stud* sections, the compliance with the end *connection* provisions of AISI S100 Section D1.2(b) is not required.

B1.3.2 When the *connection* requirements of Section D1.2 of AISI S100 [CSA S136] or the exception permitted in B1.3.1 are not met, the *available strength* [*factored resistance*] of built-up sections shall be equal to the sum of the *available strengths* [*factored resistances*] of the individual members of the built-up cross-section.

B1.4 Properties of Sections

The properties of sections shall be full cross-section properties, except where use of a reduced cross-section or effective design width is required by AISI S100 [CSA S136].

B1.5 Connection Design

Connections using screws, welds, bolts, or power-actuated fasteners shall be designed in accordance with AISI S100 [CSA S136] and the additional requirements of this Standard. For *connections* using other fastener types, design values [*factored resistances*] shall be determined

by testing in accordance with Section F1 of AISI S100 [CSA S136].

B1.5.1 Screw Connections

B1.5.1.1 Steel-to-Steel Screws

Screw fasteners for steel-to-steel *connections* shall be in compliance with ASTM C1513 or the *approved construction documents*.

B1.5.1.2 Sheathing Screws

Screw fasteners for *structural sheathing* to steel *connections* shall be in compliance with ASTM C1513 or the *approved construction documents*.

B1.5.1.3 Spacing and Edge Distance

B1.5.1.3.1 For screw fasteners in steel-to-steel *connections* to be considered fully effective, the minimum edge distance shall be 3 times the nominal diameter.

Exception: Where the edge is parallel to the direction of the applied force, the minimum edge distance of screw fasteners shall be 1.5 times the nominal diameter.

B1.5.1.3.2 For screw fasteners in steel-to-steel *connections* to be considered fully effective, the minimum center-to-center spacing shall be 3 times the nominal diameter.

Exception: Where the center-to-center spacing of screw fasteners in steel-to-steel *connections* is less than 3 times the nominal diameter but greater than or equal to 2 times the nominal diameter, screw fasteners shall be considered 80 percent effective.

B1.5.1.4 Gypsum Board

Screw fasteners for gypsum board to steel *connections* shall be bugle head style in compliance with ASTM C954, ASTM C1002, or ASTM C1513, as applicable.

B1.5.2 Welded Connections

Welded *connections* shall be in accordance with AISI S100 [CSA S136] and AWS D1.3. The design capacity of welds shall be in accordance with AISI S100 [CSA S136].

B1.5.3 Bolts

Bolted *cold-formed steel connections* shall be designed and installed in accordance with AISI S100 [CSA S136].

B1.5.4 Power-Actuated Fasteners

Cold-formed steel connections using power-actuated fasteners shall be designed and installed in accordance with AISI S100 [CSA S136].

B1.5.5 Other Connectors

Other types of *connections* (e.g., rivet fasteners and clinch joining) shall be designed, fabricated and installed in accordance with the design requirements as set forth by the *approved construction documents* and the fastener manufacturer's requirements.

B1.5.6 Connection to Other Materials

Bolts, nails, anchor bolts or other fasteners used to connect *cold-formed steel* framing to wood, masonry, concrete or other steel components shall be designed and installed in accordance with the *applicable building code* or the *approved construction documents*.

B2 Floor and Ceiling Framing

The requirements in Section B2 shall be used in conjunction with the requirements in Section B1, as applicable.

B2.1 Scope

Sections B2.2 through B2.7 are applicable to floor and ceiling systems that utilize *cold-formed steel structural members*.

B2.2 Floor Joist Design

Floor joists shall be designed in accordance with the requirements of this section.

B2.2.1 Bending

The *available bending strength [factored resistance]* of *floor joists* shall be the lesser of the strengths determined in accordance with Sections B2.2.1.1 and B2.2.1.2.

B2.2.1.1 Lateral-Torsional Buckling

Floor joists shall be designed either on the basis of discretely braced design or on the basis of continuously braced design, in accordance with the following:

- (a) Discretely Braced Design. For discretely braced design, flexure shall be evaluated in accordance with Section C3.1.2 of AISI S100 [CSA S136].
- (b) Continuously Braced Design. For continuously braced design, where *structural sheathing* or steel deck is attached to the compression *flange* of the *floor joist* in accordance with Section B2.6(1) and the tension *flange* is braced in accordance with Section B2.6(2), flexure shall be evaluated in accordance with Section C3.1.1 of AISI S100 [CSA S136].

B2.2.1.2 Distortional Buckling

Floor joists shall be designed either on the basis of discretely braced design or on the basis of continuously braced design, in accordance with the following:

- (a) Discretely Braced Design. For discretely braced design, flexure shall be evaluated in accordance with Section C3.1.4 of AISI S100 [CSA S136]. If the discrete *bracing* restricts rotation of the compression *flange* about the *web/flange* juncture, the distance between braces shall be used as L_m when applying AISI S100 [CSA S136].
- (b) Continuously Braced Design. For continuously braced design, flexure shall be evaluated in accordance with Section C3.1.4 of AISI S100 [CSA S136]. The rotational stiffness, k_ϕ , provided by the sheathing or deck to the *floor joist* shall be determined in accordance with Appendix 1.

B2.2.2 Shear

Shear shall be evaluated in accordance with Section C3.2 of AISI S100 [CSA S136].

B2.2.3 Web Crippling

Web crippling shall be evaluated in accordance with Section C3.4 of AISI S100 [CSA S136], unless a *bearing stiffener* is used in accordance with the requirements of Section B2.5.1.

B2.2.4 Bending and Shear

The combination of flexure and shear shall be evaluated in accordance with Section C3.3 of AISI S100 [CSA S136].

B2.2.5 Bending and Web Crippling

The combination of flexure and web crippling shall be evaluated in accordance with Section C3.5 of AISI S100 [CSA S136], unless a *bearing stiffener* is used in accordance with the requirements of Section B2.5.1.

B2.3 Ceiling Joist Design

Ceiling joists shall be designed in accordance with the requirements of this section.

B2.3.1 Tension

Tension shall be evaluated in accordance with Section C2 of AISI S100 [CSA S136].

B2.3.2 Compression

The *available* compression strength [*factored resistance*] of *ceiling joists* shall be the lesser of the strengths determined in accordance with Sections B2.3.2.1 and B2.3.2.2.

B2.3.2.1 Yielding, Flexural, Flexural-Torsional and Torsional Buckling

Compression shall be evaluated in accordance with Section C4.1 of AISI S100 [CSA S136].

B2.3.2.2 Distortional Buckling

Ceiling joists shall be designed either on the basis of discretely braced design or on the basis of continuously braced design, in accordance with the following:

- (a) Discretely Braced Design. For discretely braced design, compression shall be evaluated in accordance with Section C4.2 of AISI S100 [CSA S136]. If the discrete *bracing* restricts rotation of the compression *flange* about the *web/flange* juncture, the distance between braces shall be used as L_m when applying AISI S100 [CSA S136].
- (b) Continuously Braced Design. For continuously braced design, compression alone shall be evaluated in accordance with Section C4.2 of AISI S100 [CSA S136]. The rotational stiffness, k_ϕ , provided by the sheathing or deck to the *ceiling joist* shall be determined in accordance with Appendix 1.

B2.3.3 Bending

The *available* flexural strength [*resistance*] of *ceiling joists* shall be the lesser of the strengths determined in accordance with Sections B2.3.3.1 and B2.3.3.2.

B2.3.3.1 Lateral-Torsional Buckling

Ceiling joists shall be designed either on the basis of discretely braced design or on

the basis of continuously braced design, in accordance with the following:

- (a) Discretely Braced Design. For discretely braced design, flexure shall be evaluated in accordance with Section C3.1.2 of AISI S100 [CSA S136].
- (b) Continuously Braced Design. For continuously braced design, where *structural sheathing* or steel deck is attached to the compression *flange* of the *ceiling joist* in accordance with Section B2.6 (1) and the tension *flange* is braced in accordance with Section B2.6(2), flexure for gravity loading shall be evaluated in accordance with Section C3.1.1 of AISI S100 [CSA S136] and flexure for uplift loading shall be evaluated in accordance with Sections C3.1.2 and D6.1.1 of AISI S100 [CSA S136].

B2.3.3.2 Distortional Buckling

Ceiling joists shall be designed either on the basis of discretely braced design or on the basis of continuously braced design, in accordance with the following:

- (a) Discretely Braced Design. For discretely braced design, flexure shall be evaluated in accordance with Section C3.1.4 of AISI S100 [CSA S136]. If the discrete *bracing* restricts rotation of the compression *flange* about the *web/flange* juncture, the distance between braces shall be used as L_m when applying AISI S100 [CSA S136].
- (b) Continuously Braced Design. For continuously braced design, flexure shall be evaluated in accordance with Section C3.1.4 of AISI S100 [CSA S136]. The rotational stiffness, k_ϕ , provided by the sheathing or deck to the *ceiling joist* shall be determined in accordance with Appendix 1.

B2.3.4 Shear

Shear shall be evaluated in accordance with Section C3.2 of AISI S100 [CSA S136].

B2.3.5 Web Crippling

Web crippling shall be evaluated in accordance with Section C3.4 of AISI S100 [CSA S136], unless a *bearing stiffener* is used in accordance with the requirements of Section B2.5.1.

B2.3.6 Axial Load and Bending

The combination of axial *load* and bending shall be evaluated in accordance with Section C5 of AISI S100 [CSA S136].

B2.3.7 Bending and Shear

The combination of flexure and shear shall be evaluated in accordance with Section C3.3 of AISI S100 [CSA S136].

B2.3.8 Bending and Web Crippling

The combination of flexure and web crippling shall be evaluated in accordance with Section C3.5 of AISI S100 [CSA S136], unless a *bearing stiffener* is used in accordance with the requirements of Section B2.5.1.

B2.4 Floor Truss Design

Floor *trusses* shall be designed in accordance with Chapter E.

B2.5 Bearing Stiffeners

Bearing stiffeners, other than clip angle *bearing stiffeners*, shall be designed in accordance with Section C3.7 of AISI S100 [CSA S136]. Clip angle *bearing stiffeners*, as permitted in Section B2.2.3, shall be designed in accordance with Section B2.5.1.

B2.5.1 Clip Angle Bearing Stiffeners

The *nominal web crippling strength [resistance]* of a *floor joist* connected to a *rim track* using a clip angle *bearing stiffener* shall be determined in accordance with the following:

$$P_n = 0.9 (P_j + P_t + 0.5A_gF_y) \quad (\text{Eq. B2.5.1-1})$$

where

P_j = *Nominal end two-flange web crippling strength [resistance]* of the *floor joist* determined in accordance with Section C3.4.1 of AISI S100 [CSA S136]

P_t = *Nominal interior two-flange web crippling strength [resistance]* of the *rim track* determined in accordance with Section C3.4.1 of AISI S100 [CSA S136]

A_g = *Gross area of the clip angle bearing stiffener*

F_y = *Yield strength of clip angle*

The *available strength [factored resistance]* shall be determined using the *safety factor* (Ω) or the *resistance factor* (ϕ) as follows:

$$\Omega_c = 1.80 \text{ for ASD}$$

$$\phi_c = 0.85 \text{ for LRFD}$$

$$\phi_c = 0.70 \text{ for LSD}$$

Equation B2.5.1-1 shall be valid for the range of parameters listed in Table B2.5.1-1, as illustrated in Figure B2.5-1.

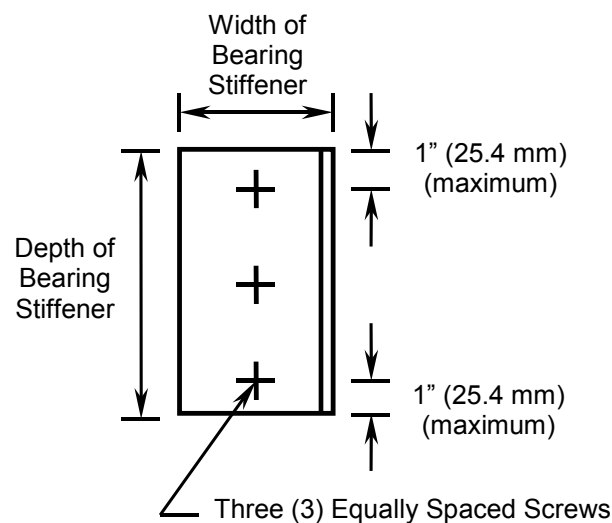

Figure B2.5-1 Fastening of Clip Angle Bearing Stiffener

Table B2.5.1-1
Parameters for Equation B2.5.1-1

Parameter	Minimum	Maximum
Floor Joist and Rim Track:		
Design Thickness	0.0451" (1.146 mm)	0.1017" (2.583 mm)
Design Yield Strength	33 ksi (228 MPa)	50 ksi (345 MPa)
Nominal Depth of Joist	8" (203 mm)	12" (305 mm)
Bearing Width	1½" (38.1 mm)	n/a
Clip Angle Bearing Stiffener:		
Size	1½"x 1½" (38.1 mm x 38.1 mm)	1½"x 1½" (38.1 mm x 38.1 mm)
Design Thickness	0.0312" (0.792 mm)	0.0713" (1.811 mm)
Design Yield Strength	33 ksi (228 MPa)	50 ksi (345 MPa)
Length	Joist depth minus 3/8" (9.5 mm)	n/a
Installation:		
Screw Size	No. 8 for angle design thickness less than or equal to 0.0566" (1.438 mm), and No. 10 for thicker angles	n/a
Fasteners	3 screws connecting legs of bearing stiffener to joist and rim track web, in accordance with Figure B2.5-1	n/a

B2.6 Bracing Design

Bracing members shall be designed either on the basis of discretely braced design or on the basis of continuously braced design, in accordance with the following:

- (a) Discretely Braced Design. For discretely braced design, *bracing* members shall be designed in accordance with Section D3 of AISI S100 [CSA S136].
- (b) Continuously Braced Design. For continuously braced design, *bracing* members shall be designed in accordance with Section D3 of AISI S100 [CSA S136], unless the following requirements, as applicable, are met:
 - (1) The sheathing or deck shall consist of a minimum of 3/8 inch (9.5 mm) wood *structural sheathing* that complies with DOC PS 1, DOC PS 2, CSA O437 or CSA O325, or steel deck with a minimum profile depth of 9/16 in. (14.3 mm) and a minimum thickness of 0.0269 in. (0.683 mm). The sheathing or deck shall be attached with minimum No. 8 screws at a maximum 12 inches (305 mm) on center.
 - (2) *Floor joists* and *ceiling joists* with simple or continuous spans that exceed 8 feet (2.44 m) shall have the tension *flanges* laterally braced. Each intermediate brace shall be spaced at 8 feet (2.44 m) maximum and shall be designed to resist a required lateral force, P_L , determined in accordance with the following:

For uniform loads:

$$P_L = 1.5(m/d) F \quad (\text{Eq. B2.6-1})$$

where

m = Distance from shear center to mid-plane of *web*

d = Depth of *C-shape* section
 F = wa
 w = Uniform design load [factored load]
 a = Distance between center line of braces

For concentrated loads:

If $x \leq 0.3a$:

$$P_L = 1.0(m/d) F \quad (\text{Eq. B2.6-2})$$

If $0.3a < x < 1.0a$:

$$P_L = 1.4(m/d)(1-x/a) F \quad (\text{Eq. B2.6-3})$$

where

m = Distance from shear center to mid-plane of *web*
 d = Depth of *C-shape* section
 F = Concentrated design load [factored load]
 x = Distance from concentrated load to brace
 a = Distance between center line of braces

B2.7 Floor Diaphragm Design

Diaphragms shall be designed in accordance with Section B5.

B3 Wall Framing

The requirements in Section B3 shall be used in conjunction with the requirements in Section B1, as applicable.

B3.1 Scope

Sections B3.2 through B3.5 are applicable to wall systems that utilize *cold-formed steel structural members*.

B3.2 Wall Stud Design

Wall *studs* shall be designed in accordance with the requirements of this section.

B3.2.1 Available Axial Strength [Factored Resistance]

The *available axial strength [factored resistance]* of wall stud shall be the lesser of the *available strengths [factored resistance]* obtained by Sections B3.2.1.1 and B3.2.1.2.

B3.2.1.1 Yielding, Flexural, Flexural-Torsional and Torsional Buckling

Wall *studs* shall be designed either on the basis of all steel design or on the basis of sheathing braced design with both ends of the *stud* connected to restrain rotation about the longitudinal stud axis and horizontal displacement perpendicular to the *stud* axis, in accordance with the following:

- (a) All Steel Design. For all steel design of wall *studs* in compression, Sections C4.1 and D4.1 of AISI S100 [CSA S136] shall define the *available axial strength [factored resistance]*. The effective length, KL , shall be determined by *rational engineering analysis* or testing, or in the absence of such analysis or tests, K_x , K_y and K_t shall be taken as unity. The unbraced length with respect to the major axis, L_x , shall be taken as the distance between end supports of the member, while unbraced lengths L_y and L_t shall be taken as the distance between braces.

- (b) Sheathing Braced Design. For sheathing braced design of wall *studs* in compression, the *available axial strength [factored resistance]* shall be determined in accordance with Section C4.1 of AISI S100 [CSA S136]. The unbraced length with respect to the major axis, L_x , shall be taken as the distance between end supports of the member. The unbraced length with respect to the minor axis, L_y , and the unbraced length for torsion, L_t , shall be taken as twice the distance between sheathing connectors. The buckling coefficients K_x , K_y , and K_t shall be taken as unity.

To prevent failure of the sheathing-to-wall *stud connection*, where identical gypsum sheathing is attached to both sides of the wall *stud* with screws spaced at a maximum of 12 inches (305 mm) on center, the maximum axial *nominal load [specified load]* in the wall *stud* shall be limited to the values given in Table B3.2-1.

Table B3.2-1
Maximum Axial Nominal Load [Specified Load]
Limited by Gypsum Sheathing-to-Wall Stud Connection Capacity

Gypsum Sheathing	Screw Size	Maximum Nominal [Specified] Stud Axial Load
1/2 inch (12.7 mm)	No. 6	5.8 kips (25.8 kN)
1/2 inch (12.7 mm)	No. 8	6.7 kips (29.8 kN)
5/8 inch (15.9 mm)	No. 6	6.8 kips (30.2 kN)
5/8 inch (15.9 mm)	No. 8	7.8 kips (34.7 kN)

B3.2.1.2 Distortional Buckling

Wall *studs* shall be designed either on the basis of all steel design or on the basis of sheathing braced design, in accordance with the following:

- (a) All Steel Design. For all steel design, compression shall be evaluated in accordance with Section C4.2 of AISI S100 [CSA S136]. If the discrete *bracing* restricts rotation of both *flanges* about the *web/flange* juncture, the distance between braces shall be used as L_m when applying AISI S100 [CSA S136].
- (b) Sheathing Braced Design. For sheathing braced design, compression shall be evaluated in accordance with Section C4.2 of AISI S100 [CSA S136]. The rotational stiffness, k_ϕ , provided by the sheathing or deck to the *wall stud* shall be determined in accordance with Appendix 1.

B3.2.2 Bending

The *available flexural strength [factored resistance]* of wall stud shall be the lesser of the *strengths [resistance]* obtained by Sections B3.2.2.1 and B3.2.2.2.

B3.2.2.1 Lateral-Torsional Buckling

Wall *studs* shall be designed either on the basis of all steel design or on the basis of sheathing braced design, in accordance with the following:

- (a) All Steel Design. For all steel design, Section C3.1.2 of AISI S100 [CSA S136] shall define the *available flexural strength [factored resistance]*.
- (b) Sheathing Braced Design. For sheathing braced design, and assuming full rotational restraint provided by the sheathing, Section C3.1.1 of AISI S100 [CSA S136] shall

define the *available flexural strength [factored resistance]*.

B3.2.2.2 Distortional Buckling

Wall *studs* shall be designed either on the basis of all steel design or on the basis of sheathing braced design, in accordance with the following:

- (a) All Steel Design. For all steel design, flexure shall be evaluated in accordance with Section C3.1.4 of AISI S100 [CSA S136]. If the discrete *bracing* restricts rotation of the compression *flange* about the *web/flange* juncture, the distance between braces shall be used as L_m when applying AISI S100 [CSA S136].
- (b) Sheathing Braced Design. For sheathing braced design, flexure shall be evaluated in accordance with Section C3.1.4 of AISI S100 [CSA S136]. The rotational stiffness, k_ϕ provided by the sheathing or deck to the compression *flange* of the *wall stud* shall be determined in accordance with Appendix 1.

B3.2.3 Shear

The *available shear strength [factored resistance]* shall be determined in accordance with Section C3.2 of AISI S100 [CSA S136].

B3.2.4 Axial Load and Bending

The combination of axial load and bending shall be evaluated in accordance with Section C5 of AISI S100 [CSA S136].

B3.2.5 Web Crippling

The *available web crippling strength [factored resistance]* shall be determined in accordance with Section C3.4 of AISI S100 [CSA S136], or shall be determined in accordance with Section B3.2.5.1 for C-section *stud-to-track connections* and Section B3.2.5.2 for C-section *stud-to-deflection track connections*.

B3.2.5.1 Stud-to-Track Connection for C-Section Studs

The *available web crippling strength [factored resistance]* of C-Section *stud-to-track connections* are permitted to be determined in accordance with Items (a) to (c), as applicable:

- (a) For single *curtain wall studs* where both *stud flanges* are connected to the *track flanges*, the nominal strength [resistance], P_{nst} shall be determined in accordance with Eq. B3.2.5.1-1. For members consisting of two studs, P_{nst} is the sum of the individual *stud web* capacities with the *stud design thickness*, t , taken as the thickness of one *web*.

$$P_{nst} = Ct^2F_y \left(1 - C_R \sqrt{\frac{R}{t}} \right) \left(1 + C_N \sqrt{\frac{N}{t}} \right) \left(1 - C_h \sqrt{\frac{h}{t}} \right) \quad (\text{Eq. B3.2.5.1-1})$$

where

- C = Web crippling coefficient listed in Table B3.2.5.1-1
- C_R = Inside bend radius coefficient
= 0.19
- C_N = Bearing length coefficient
= 0.74

- C_h = Web slenderness coefficient
 = 0.019
 R = Stud inside bend radius
 N = Stud bearing length
 = 1.25 inch (32 mm)
 h = Depth of flat portion of stud web measured along plane of web
 t = Stud design thickness

The available strength [factored resistance] shall be determined using the safety factor (Ω) or the resistance factor (ϕ) as follows:

- Ω = 1.70 for ASD for single stud interior configuration
 = 1.90 for ASD for all other configurations listed in Table B3.2.5.1-1
 ϕ = 0.90 for LRFD for single stud interior configuration
 = 0.85 for LRFD for all other configurations listed in Table B3.2.5.1-1
 = 0.75 for LSD for single stud interior configuration
 = 0.70 for LSD for all other configurations listed in Table B3.2.5.1-1

Equation B3.2.5.1-1 shall be valid for the range of parameters listed in Table B3.2.5.1-2.

Table B3.2.5.1-1
Web Crippling Coefficients

Configuration	Location	Web Crippling Coefficient, C
Single stud	Interior	3.70
Single stud with reinforcing lips facing opening	At a wall opening	2.78
Single stud with stud web facing opening	At a wall opening	1.85
Toe-to-toe double studs	Interior	7.40
Toe-to-toe double studs	At an opening	5.55
Back-to-back double studs	Interior	7.40
Back-to-back double studs	At an opening	7.40

Table B3.2.5.1-2
Parameters for Equation B3.2.5.1-1

Parameter	Minimum	Maximum
Screw Size	No. 8 for 0.0451 in. (1.146 mm) and thinner stud design thickness No. 10 for 0.0452 to 0.0566 in. (1.147 to 1.438 mm) stud design thickness No. 12 for 0.0567 in. (1.439 mm) and thicker stud design thickness	n/a
Stud Section:		
Design Thickness	0.0346 inch (0.88 mm)	0.0770 inch (1.96 mm)
Design Yield Strength	33 ksi (228 MPa)	50 ksi (345 MPa)
Nominal Depth	3.50 inch (88.9 mm)	6.0 inch (152.4 mm)
Track Section:		
Design Thickness	0.0346 inch (0.88 mm)	0.0770 inch (1.96 mm)
Design Yield Strength	33 ksi (228 MPa)	50 ksi (345 MPa)
Nominal Depth	3.50 inch (88.9 mm)	6.0 inch (152.4 mm)
Nominal Flange Width	1.25 inch (31.8 mm)	2.375 inch (60.3 mm)

- (b) For single *curtain wall studs* that are not adjacent to wall openings and where both *stud flanges* are connected to the *track flanges* and the *track* thickness is less than the *stud* thickness, the *nominal strength [resistance]*, P_{nst} shall be the lesser value determined in accordance with Equation B3.2.5.1-1 or B3.2.5.1-2.

$$P_{nst} = 0.6 t_t w_{st} F_{ut} \quad (\text{Eq. B3.2.5.1-2})$$

where:

t_t = Track design thickness

w_{st} = $20 t_t + 0.56\alpha$

α = Coefficient for conversion of units
= 1.0 when t_t is in inches
= 25.4 when t_t is in mm

F_{ut} = Tensile strength of the track

P_{nst} = Nominal strength [resistance] for the stud-to-track connection when subjected to transverse loads

The available strength [factored resistance] shall be determined using the safety factor (Ω) or the resistance factor (ϕ) as follows:

Ω = 1.70 for ASD

ϕ = 0.90 for LRFD

= 0.80 for LSD

Equation B3.2.5.1-2 shall be valid for the range of parameters listed in Table B3.2.5.1-3.

**Table B3.2.5.1-3
Parameters for Equation B3.2.5.1-2**

Parameter	Minimum	Maximum
Screw Size	No. 8	n/a
Stud Section:		
Design Thickness	0.0346 inch (0.88 mm)	0.0770 inch (1.96 mm)
Design Yield Strength	33 ksi (228 MPa)	50 ksi (345 MPa)
Nominal Depth	3.50 inch (88.9 mm)	6.0 inch (152.4 mm)
Track Section:		
Design Thickness	0.0346 inch (0.88 mm)	0.0770 inch (1.96 mm)
Design Yield Strength	33 ksi (228 MPa)	50 ksi (345 MPa)
Nominal Depth	3.50 inch (88.9 mm)	6.0 inch (152.4 mm)
Nominal Flange Width	1.25 inch (31.8 mm)	2.375 inch (60.3 mm)

(c) For *curtain wall jamb studs* made up of two *studs* connected back-to-back where both *stud flanges* are connected to the *track flanges* and the *track* thickness is the same as the *stud* thickness, the *nominal strength [resistance]*, P_{nst} , is the lesser value determined in accordance with Equation B3.2.5.1-1 or B3.2.5.1-3.

$$P_{nst} = 15.2 t_t^2 F_{ut} \quad (\text{Eq. B3.2.5.1-3})$$

where

t_t = Track design thickness

F_{ut} = Tensile strength of the track

The *available strength [factored resistance]* shall be determined using the *safety factor* (Ω) or the *resistance factor* (ϕ) as follows:

Ω = 2.10 for ASD

ϕ = 0.75 for LRFD

= 0.65 for LSD

Equation B3.2.5.1-3 shall be valid for the range of parameters listed in Table B3.2.5.1-4.

**Table B3.2.5.1-4
Parameters for Equation B3.2.5.1-3**

Parameter	Minimum	Maximum
Screw Size	No. 10	n/a
Stud Section:		
Design Thickness	0.0346 inch (0.88 mm)	0.0770 inch (1.96 mm)
Design Yield Strength	33 ksi (228 MPa)	50 ksi (345 MPa)
Nominal Depth	3.50 inch (88.9 mm)	6.0 inch (152.4 mm)
Track Section:		
Design Thickness	0.0346 inch (0.88 mm)	0.0770 inch (1.96 mm)
Design Yield Strength	33 ksi (228 MPa)	50 ksi (345 MPa)
Nominal Depth	3.50 inch (88.9 mm)	6.0 inch (152.4 mm)
Nominal Flange Width	1.25 inch (31.8 mm)	1.25 inch (31.8 mm)

- (d) For *curtain wall studs* that are not adjacent to wall openings and do not have both *stud flanges* connected to the *track flanges* and the *track thickness* is greater than or equal to the *stud thickness*, *nominal strength [resistance]*, P_{nst} shall equal P_n , along with Ω and ϕ , as determined by Section C3.4.1 of AISI S100 [CSA S136]. For two *studs* connected back-to-back, the two members shall be considered individually as single *web* members.
- (e) For *curtain wall studs* that are adjacent to wall openings and do not have both *stud flanges* connected to the *track flanges* and the *track thickness* is greater than or equal to the *stud thickness*, *nominal strength [resistance]*, P_{nst} shall equal $0.5P_n$, along with Ω and ϕ , as determined by Section C3.4.1 of AISI S100 [CSA S136]. For two *studs* connected back-to-back, the two members shall be considered individually as single *web* members.

B3.2.5.2 Deflection Track Connection for C-Section Studs

B3.2.5.2.1 For *curtain wall studs* used in *deflection track connections*, the *nominal web crippling strength [resistance]*, P_{nst} and the Ω and ϕ factors shall be determined by Section C3.4.1 of AISI S100 [CSA S136]. The bearing length used in these calculations shall not exceed the minimum engagement between the *stud* and the *track* or 1 inch (25.4 mm).

B3.2.5.2.2 The *nominal strength [resistance]* of a single *deflection track* subjected to transverse *loads* and connected to its support at a fastener spacing not greater than the *stud* spacing shall be determined in accordance with Eq. B3.2.5.2-1.

$$P_{ndt} = \frac{w_{dt} t_t^2 F_y}{4e} \quad (\text{Eq. B3.2.5.2-1})$$

where

$$w_{dt} = \text{Effective track length} \\ = 0.11(\alpha^2)(e^{0.5}/t_t^{1.5}) + 5.5\alpha \leq S \quad (\text{Eq. B3.2.5.2-2})$$

S = Center-to-center spacing of *studs*

t_t = *Track design thickness*

F_y = *Design yield strength* of track material

e = Design end or slip gap (distance between *stud web* at end of *stud* and *track web*)

α = Coefficient for conversion of units

= 1.0 when e , t_t and S are in inches

= 25.4 when e , t_t and S are in mm

The *available strength [factored resistance]* shall be determined using the *safety factor* (Ω) or the *resistance factor* (ϕ) as follows:

Ω = 2.80 for ASD

ϕ = 0.55 for LRFD

= 0.45 for LSD

Equation B3.2.5.2-1 shall be valid for the range of parameters listed in Table B3.2.5.2-1. Additionally, the horizontal distance from the *web* side of the *stud* to the terminating end of the *track* shall not be less than one-half the effective *track* length w_{dt} .

Table B3.2.5.2-1
Parameters for Equation B3.2.5.2-1

Parameter	Minimum	Maximum
Screw Size	No. 10	n/a
Stud Section:		
Design Thickness	0.0451 inch (1.14 mm)	0.0713 inch (1.81 mm)
Design Yield Strength	33 ksi (228 MPa)	50 ksi (345 MPa)
Nominal Depth	3.50 inch (88.9 mm)	6.0 inch (152.4 mm)
Nominal Flange Width	1.625 inch (41.3 mm)	2.50 inch (63.5 mm)
Stud Spacing	12 inch (305 mm)	24 inch (610 mm)
Stud Bearing Length	$\frac{3}{4}$ inch (19.1 mm)	n/a
Track Section:		
Design Thickness	0.0451 inch (1.14 mm)	0.0713 inch (1.81 mm)
Design Yield Strength	33 ksi (228 MPa)	50 ksi (345 MPa)
Nominal Depth	3.50 inch (88.9 mm)	6.0 inch (152.4 mm)
Nominal Flange Width	2.00 inch (50.8 mm)	3.00 inch (76.3 mm)

B3.3 Header Design

B3.3.1 Back-to-Back Headers

The requirements of this section shall be limited to back-to-back *header* beams that are installed using *cold-formed steel C-shape* sections in accordance with Section C3.4.4.

B3.3.1.1 Bending

Bending shall be evaluated in accordance with Section C3.1.1 of AISI S100 [CSA S136].

B3.3.1.2 Shear

Shear shall be evaluated in accordance with Section C3.2 of AISI S100 [CSA S136].

B3.3.1.3 Web Crippling

Web crippling shall be evaluated in accordance with Section C3.4 of AISI S100 [CSA S136]. For back-to-back *header* beams, the coefficients for built-up sections in Table C3.4.1-1 of AISI S100 [CSA S136] shall be used.

B3.3.1.4 Bending and Shear

The combination of bending and shear shall be evaluated in accordance with Section C3.3 of AISI S100 [CSA S136].

B3.3.1.5 Bending and Web Crippling

Webs of back-to-back *header* beams subjected to a combination of bending and web crippling shall be designed in accordance with Section C3.5 of AISI S100 [CSA S136]. For back-to-back *header* beams, AISI S100 [CSA S360] Sections C3.5.1 (b) for *ASD* and C3.5.2 (b) for *LRFD* and *LSD* shall be used.

B3.3.2 Box Headers

The requirements of this section shall be limited to box *header* beams that are installed using *cold-formed steel C-shape* sections in accordance with Section C3.4.4.

B3.3.2.1 Bending

Bending shall be evaluated in accordance with Section C3.1.1 of AISI S100 [CSA S136].

B3.3.2.2 Shear

Shear shall be evaluated in accordance with Section C3.2 of AISI S100 [CSA S136].

B3.3.2.3 Web Crippling

Web crippling shall be evaluated in accordance with Section C3.4 of AISI S100 [CSA S136]. For box *header* beams, the equations for shapes having single *webs* shall be used. The *nominal* web crippling strength [*resistance*], P_{nv} for an interior one-*flange* loading condition, with the applicable Ω or ϕ factor specified below, is permitted to be multiplied by α , where α accounts for the increased strength due to the *track* and is specified as follows:

α = Parameter determined in accordance with equation B3.3.2.3-1 or B3.3.2.3-2

The *available strength* [*factored resistance*] shall be determined using the *safety factor* (Ω) or the *resistance factor* (ϕ) as follows:

$\Omega = 1.80$ for ASD

$\phi = 0.85$ for LRFD

$\phi = 0.80$ for LSD

Where the *track* section *design thickness* ≥ 0.0346 in. (0.879 mm), the *track flange* width ≥ 1 in. (25.4 mm), the *C-shape* section depth ≤ 12 in. (305 mm) and the *C-shape* section *design thickness* ≥ 0.0346 in. (0.879 mm):

$$\alpha = 2.3 \frac{t_t}{t_c} \geq 1.0 \quad (\text{Eq. B3.3.2.3-1})$$

where

$t_t = 0.0346$ in. (0.879 mm)

$t_c =$ *Design thickness* of the *C-shape* section

Where the limits of Equation B3.3.2.3-1 are not met:

$$\alpha = 1.0 \quad (\text{Eq. B3.3.2.3-2})$$

B3.3.2.4 Bending and Shear

The combination of bending and shear shall be evaluated in accordance with Section C3.3 of AISI S100 [CSA S136].

B3.3.2.5 Bending and Web Crippling

Webs of box *header* beams subjected to a combination of bending and web crippling shall be determined in accordance with either Section C3.5 of AISI S100 [CSA S136] or the following equations:

(a) For ASD:

$$\frac{P}{P_n} + \frac{M}{M_n} \leq \frac{1.5}{\Omega} \quad (\text{Eq. B3.3.2.5-1})$$

where

P = Required web crippling strength

M = Required flexural strength

P_n = Nominal web crippling strength determined in accordance with Section B3.3.2.3

M_n = Nominal flexural strength defined in Section C3.1 of AISI S100 [CSA S136]

The available strength [factored resistance] shall be determined using the safety factor (Ω) as follows:

$$\Omega = 1.85$$

(b) For LRFD and LSD:

$$\frac{P_u}{P_n} + \frac{M_u}{M_n} \leq 1.5\phi \quad (\text{Eq. B3.3.2.5-2})$$

where

P_u = Required web crippling strength [compression force due to factored loads]

M_u = Required flexural strength [moment due to factored loads]

P_n = Nominal web crippling strength [resistance] computed by Section B3.3.2.3

M_n = Nominal flexural strength [resistance] defined in Section C3.1 of AISI S100 [CSA S136]

The available strength [factored resistance] shall be determined using the resistance factor (ϕ) as follows:

$$\phi = 0.85 \text{ for LRFD}$$

$$\phi = 0.80 \text{ for LSD}$$

B3.3.3 Double L-Headers

The requirements of this section shall be limited to double L-headers that are installed using two cold-formed steel angles in accordance with Section C3.4.5 and meet all of the following conditions:

- (a) Minimum top flange width = 1.5 inches (38.1 mm)
- (b) Maximum vertical leg dimension = 10 inches (254 mm)
- (c) Minimum base steel thickness = 0.033 inches (0.838 mm)
- (d) Maximum design thickness = 0.0713 inches (1.829 mm)
- (e) Minimum design yield strength, $F_y = 33$ ksi (230 MPa)
- (f) Maximum design yield strength, $F_y = 50$ ksi (345 MPa)
- (g) Cripple stud located at all load points
- (h) Minimum bearing length 1.5 inches (38.1 mm) at load points
- (i) Minimum wall width = 3.5 inches (88.9 mm)
- (j) Maximum span = 16 ft.-0 in. (4.88 m)

B3.3.3.1 Bending

The *available flexural strength [factored resistance]* of double L-headers shall be determined in accordance with this section.

B3.3.3.1.1 Gravity Loading

The gravity *nominal flexural strength [moment resistance]*, M_{ng} , shall be determined as follows:

$$\begin{aligned} M_{ng} &= S_{ec} F_y && \text{when } L/L_h \geq 10 && \text{(Eq. B3.3.3.1.1-1)} \\ &= 0.9 S_{ec} F_y && \text{when } L/L_h < 10 \text{ and } L_h > 8 \text{ in. (203 mm)} && \text{(Eq. B3.3.3.1.1-2)} \end{aligned}$$

The *available strength [factored resistance]* shall be determined using the *safety factor* (Ω) or the *resistance factor* (ϕ) as follows:

For $L_h \leq 8$ in. (203 mm):

$$\begin{aligned} \Omega &= 1.67 \text{ (ASD)} \\ \phi &= 0.90 \text{ (LRFD)} \\ &= 0.85 \text{ (LSD)} \end{aligned}$$

For $L_h > 8$ in. (203 mm):

$$\begin{aligned} \Omega &= 2.25 \text{ (ASD)} \\ \phi &= 0.70 \text{ (LRFD)} \\ &= 0.65 \text{ (LSD)} \end{aligned}$$

where

F_y = Yield strength used for design

S_{ec} = Elastic section modulus of the effective section calculated at $f = F_y$ in the extreme compression fibers

L = Span length

L_h = Vertical leg dimension of angle

B3.3.3.1.2 Uplift Loading

The *nominal uplift flexural strength [moment resistance]*, M_{nu} , shall be determined as follows:

$$M_{nu} = R M_{ng} \quad \text{(Eq. B3.3.3.1.2-1)}$$

The *available strength [factored resistance]* shall be determined using the *safety factor* (Ω) or the *resistance factor* (ϕ) as follows:

$$\begin{aligned} \Omega &= 2.0 \text{ (ASD)} \\ \phi &= 0.80 \text{ (LRFD)} \\ &= 0.75 \text{ (LSD)} \end{aligned}$$

where

M_{ng} = Gravity *nominal flexural strength [moment resistance]* determined by Eq. B3.3.3.1.2-1

R = Uplift factor

= 0.25 for $L_h/t \leq 150$

= 0.20 for $L_h/t \geq 170$

= For $150 < L_h/t < 170$ use linear interpolation

L_h = Vertical leg dimension of the angle

t = Design thickness

B3.3.3.2 Shear

Shear need not be evaluated for the design of double *L-header* beams that are fabricated and installed in accordance with this Standard.

B3.3.3.3 Web Crippling

Web crippling need not be evaluated for the design of double *L-header* beams that are fabricated and installed in accordance with this Standard.

B3.3.3.4 Bending and Shear

The combination of bending and shear need not be evaluated for the design of double *L-header* beams fabricated and installed in accordance with this Standard.

B3.3.3.5 Bending and Web Crippling

The combination of bending and web crippling need not be evaluated for the design of double *L-header* beams fabricated and installed in accordance with this Standard.

B3.3.4 Single L-Headers

The requirements of this section shall be limited to single *L-headers* that are installed using one *cold-formed steel* angle in accordance with Section C3.4.5 and meet all of the following conditions:

- (a) Minimum top *flange* width = 1.5 inches (38.1 mm)
- (b) Maximum vertical leg dimension = 8 inches (203 mm)
- (c) Minimum *base steel thickness* = 0.033 inches (0.838 mm)
- (d) Maximum *design thickness* = 0.0566 inches (1.448 mm)
- (e) Minimum design *yield strength*, $F_y = 33$ ksi (230 MPa)
- (f) Maximum design *yield strength*, $F_y = 50$ ksi (345 MPa)
- (g) Cripple *stud* located at all *load* points
- (h) Minimum bearing length 1.5 inches (38.1 mm) at *load* points
- (i) Minimum wall width = 3.5 inches (88.9 mm)
- (j) Maximum *span* = 4'-0" (1.219 m)

B3.3.4.1 Bending

The *available flexural strength [factored resistance]* of single *L-headers* shall be determined in accordance with this section.

B3.3.4.1.1 Gravity Loading

The gravity *nominal flexural strength [resistance]*, M_{ng} , shall be determined as follows:

$$\begin{aligned} M_{ng} &= S_{ec} F_y && \text{when } L_h \leq 6 \text{ in. (152 mm)} && \text{(Eq. B3.3.4.1.1-1)} \\ &= 0.9 S_{ec} F_y && \text{when } 6 \text{ in. (152 mm)} < L_h \leq 8 \text{ in. (203 mm)} && \text{(Eq. B3.3.4.1.1-1)} \end{aligned}$$

The *available strength [factored resistance]* shall be determined using the *safety factor* (Ω) or the *resistance factor* (ϕ) as follows:

$$\Omega = 1.67 \text{ (ASD)}$$

$$\begin{aligned}\phi &= 0.90 \text{ (LRFD)} \\ &= 0.85 \text{ (LSD)}\end{aligned}$$

where

F_y = Yield strength used for design

S_{ec} = Elastic section modulus of the effective section calculated at $f = F_y$ in the extreme compression fibers

B3.3.4.1.2 Uplift Loading

[Reserved]

B3.3.4.2 Shear

Shear need not be evaluated for the design of single *L-header* beams that are fabricated and installed in accordance with this Standard.

B3.3.4.3 Web Crippling

Web crippling need not be evaluated for the design of single *L-header* beams that are fabricated and installed in accordance with this Standard.

B3.3.4.4 Bending and Shear

The combination of bending and shear need not be evaluated for the design of single *L-header* beams fabricated and installed in accordance with this Standard.

B3.3.4.5 Bending and Web Crippling

The combination of bending and web crippling need not be evaluated for the design of single *L-header* beams fabricated and installed in accordance with this Standard.

B3.3.5 Inverted L-Header Assemblies

B3.3.5.1 The requirements of this section shall be limited to inverted double or single *L-header* assemblies satisfying the limitations specified in Section B3.3.3 for double *L-headers* and B3.3.4 for single *L-headers*, respectively. The installation of inverted *L-header* assemblies shall be in accordance with C3.4.6.

B3.3.5.2 For double inverted *L-header* assemblies, the *nominal flexural strength* [moment resistance] of the combined *L-header* assembly (i.e., double *L-headers* plus inverted double *L-headers*) shall be determined by summing the gravity and uplift *nominal flexural strengths* [moment resistances] as determined in accordance with Section B3.3.3.1.

B3.3.5.3 For single inverted *L-header* assemblies, the *nominal flexural strength* [moment resistance] of the combined *L-header* assembly (i.e., a single *L-header* plus an inverted single *L-header*) shall be based on the gravity *nominal flexural strength* [moment resistance] as determined in accordance with Section B3.3.4.1.

B3.3.5.4 Shear, web crippling, bending and shear, and bending and web crippling need not be evaluated for the design of inverted *L-headers* fabricated and installed in accordance with this Standard.

B3.4 Bracing

B3.4.1 Intermediate Brace Design

B3.4.1.1 For bending members, each intermediate brace shall be designed in accordance with Section D3.2.1 of AISI S100 [CSA S136].

B3.4.1.2 For axial loaded members, each intermediate brace shall be designed for 2% of the design compression force in the member.

B3.4.1.3 For combined bending and axial *loads*, each intermediate brace shall be designed for the combined brace force determined in accordance with Section D3.2.1 of AISI S100 [CSA S136] and 2% of the design compression force in the member.

B3.5 Serviceability

Serviceability limits shall be chosen based on the intended function of the wall system, and shall be evaluated using *load* and *load* combinations in accordance with Section B1.1.

B4 Roof Framing

The requirements in Section B4 shall be used in conjunction with the requirements in Section B1, as applicable.

B4.1 Scope

Sections B4.2 through B4.6 are applicable to roof systems that utilize *cold-formed steel structural members*.

B4.2 Roof Rafter Design

Roof rafters shall be designed in accordance with the requirements of this section.

B4.2.1 Tension

Tension shall be evaluated in accordance with Section C2 of AISI S100 [CSA S136].

B4.2.2 Compression

The *available* compression *strength* [*resistance*] of *roof rafters* shall be the lesser values obtained from Sections B4.2.2.1 and B4.2.2.2.

B4.2.2.1 Yielding, Flexural, Flexural-Torsional and Torsional Buckling

Compression shall be evaluated in accordance with Section C4.1 of AISI S100 [CSA S136].

B4.2.2.2 Distortional Buckling

Roof rafters shall be designed either on the basis of discretely braced design or on the basis of continuously braced design, in accordance with the following:

- (a) Discretely Braced Design. For discretely braced design, compression shall be evaluated in accordance with Section C4.2 of AISI S100 [CSA S136]. If the discrete *bracing* restricts rotation of the compression *flange* about the *web/flange* juncture, the distance between braces shall be used as L_m when applying AISI S100 [CSA S136].
- (b) Continuously Braced Design. For continuously braced design, compression shall be evaluated in accordance with Section C4.2 of AISI S100 [CSA S136]. The rotational

stiffness, k_{ϕ} , provided by the sheathing or deck to the *roof rafter* shall be determined in accordance with Appendix 1.

B4.2.3 Bending

The *available flexural strength [resistance]* of *roof rafters* shall be the lesser values obtained from Sections B4.2.3.1 and B4.2.3.2.

B4.2.3.1 Lateral-Torsional Buckling

Roof rafters shall be designed either on the basis of discretely braced design or on the basis of continuously braced design, in accordance with the following:

- (a) Discretely Braced Design. For discretely braced design, flexure shall be evaluated in accordance with Section C3.1.2 of AISI S100 [CSA S136].
- (b) Continuously Braced Design. For continuously braced design, where *structural sheathing* or steel deck is attached to the compression *flange* of the *roof rafter* in accordance with Section B4.5(1) and the tension *flange* is braced in accordance with Section B4.5(2), flexure for gravity loading shall be evaluated by using Section C3.1.1 of AISI S100 [CSA S136] and flexure for uplift loading shall be evaluated in accordance with Sections C3.1.2 and D6.1.1 of AISI S100 [CSA S136]. Where *structural sheathing* or steel deck is attached to both *flanges* of the *roof rafter* in accordance with Section B4.5(1), flexure for gravity or uplift loading shall be evaluated in accordance with Section C3.1.1 of AISI S100 [CSA S136].

B4.2.3.2 Distortional Buckling

Roof rafters shall be designed either on the basis of discretely braced design or on the basis of continuously braced design, in accordance with the following:

- (a) Discretely Braced Design. For discretely braced design, flexure alone shall be evaluated in accordance with Section C3.1.4 of AISI S100 [CSA S136]. If the discrete *bracing* restricts rotation of the compression *flange* about the *web/flange* juncture, the distance between braces shall be used as L_m when applying AISI S100 [CSA S136].
- (b) Continuously Braced Design. For continuously braced design, flexure shall be evaluated in accordance with Section C3.1.4 of AISI S100 [CSA S136]. The rotational stiffness, k_{ϕ} , provided by the sheathing or deck to the *roof rafter* shall be determined in accordance with Appendix 1.

B4.2.4 Shear

Shear shall be evaluated in accordance with Section C3.2 of AISI S100 [CSA S136].

B4.2.5 Web Crippling

Web crippling shall be evaluated in accordance with Section C3.4 of AISI S100 [CSA S136], unless a *bearing stiffener* is used in accordance with the requirements of Section B4.4.

B4.2.6 Axial Load and Bending

The combination of axial *load* and bending shall be evaluated in accordance with Section C5 of AISI S100 [CSA S136].

B4.2.7 Bending and Shear

The combination of flexure and shear shall be evaluated in accordance with Section C3.3 of AISI S100 [CSA S136].

B4.2.8 Bending and Web Crippling

The combination of flexure and web crippling shall be evaluated in accordance with Section C3.5 of AISI S100 [CSA S136], unless a *bearing stiffener* is used in accordance with the requirements of Section B4.4.

B4.3 Roof Truss Design

Roof *trusses* shall be designed in accordance with Chapter E.

B4.4 Bearing Stiffeners

Bearing stiffeners shall be designed in accordance with Section C3.7 of AISI S100 [CSA S136].

B4.5 Bracing Design

Bracing members shall be designed in accordance with Section D3 of AISI S100 [CSA S136], unless *bracing* is provided satisfying the following requirements:

- (a) In continuously braced design, the sheathing or deck shall consist of a minimum of 3/8 inch (9.5 mm) wood *structural sheathing* that complies with DOC PS 1, DOC PS 2, CSA O437 or CSA O325, or steel deck with a minimum profile depth of 9/16 in. (14.3 mm) and a minimum thickness of 0.0269 in. (0.683 mm). The sheathing or deck shall be attached with minimum No. 8 screws at a maximum 12 inches (305 mm) on center.
- (b) In continuously braced design, *roof rafters* with simple or continuous spans that exceed 8 feet (2.44 m) shall have the tension *flanges* laterally braced. Each intermediate brace shall be spaced at 8 feet (2.44 m) maximum and shall be designed to resist a required lateral force, P_L , determined in accordance with the following:

- (1) For uniform *loads*:

$$P_L = 1.5(m/d) F \quad (\text{Eq. B4.5-1})$$

where

m = Distance from shear center to mid-plane of *web*

d = Depth of *C-shape* section

F = $w a$

w = Uniform *design load* [*factored load*]

a = Distance between center line of braces

- (2) For concentrated *loads*:

If $x \leq 0.3a$

$$P_L = 1.0(m/d) F \quad (\text{Eq. B4.5-2})$$

If $0.3a < x < 1.0a$

$$P_L = 1.4(m/d)(1-x/a) F \quad (\text{Eq. B4.5-3})$$

where

m = Distance from shear center to mid-plane of *web*

d = Depth of *C-shape* section

F = Concentrated *design load* [*factored load*]

- x = Distance from concentrated *load* to brace
 a = Distance between center line of braces

B4.6 Roof Diaphragm Design

Diaphragms shall be designed in accordance with Section B5.4.

B5 Lateral Force-Resisting Systems

The requirements in Section B5 shall be used in conjunction with the requirements in Section B1, as applicable.

B5.1 Scope

Sections B5.2 through B5.5 are applicable to buildings that utilize *cold-formed steel structural members* for *lateral force-resisting system* framing.

User Note:

See Section A1.3 for applicability of this section to cold-formed steel structural members and connections in seismic force-resisting systems.

B5.2 Shear Wall Design

Shear walls shall be designed as either *Type I shear walls* or *Type II shear walls* in accordance with the requirements of this section and shall be installed in accordance with the requirements of Section C3.6.1.

User Note:

See Section A1.3 for applicability of this section to cold-formed steel structural members and connections in seismic force-resisting systems.

B5.2.1 General

Type I shear walls shall be fully sheathed with *steel sheet sheathing*, *wood structural panels*, *gypsum board panels*, or *fiberboard panels* with *hold-downs* at each end. *Type I shear walls* sheathed with *steel sheet sheathing* or *wood structural panels* are permitted to have openings where details are provided to account for force transfer around openings. *Type I shear walls* shall conform to the additional requirements of Sections B5.2.1.1.

Type II shear walls shall be sheathed with *steel sheet sheathing* or *wood structural panels* with a *Type II shear wall segment* at each end. Openings are permitted to occur beyond the ends of the *Type II shear wall*; however, the width of such openings shall not be included in the length of the *Type II shear wall*. *Type II shear walls* shall conform to the additional requirements of Section B5.2.1.2.

B5.2.1.1 Type I Shear Walls

Type I shear walls shall conform to the following requirements:

- (a) The height-to-length aspect ratio (h/w) of a *Type I shear wall* does not exceed the values in Tables B5.2.2.3-1 through B5.2.2.3-4.
- (b) The length of a *Type I shear wall* is not less than 24 inches (610 mm).
- (c) The height-to-length aspect ratio (h_p/w_p) of a *wall pier* in a *Type I shear wall* with openings is limited to a maximum of 2:1, where the height of a *wall pier* (h_p) is defined as the height of the opening adjacent to the sheathed wall and the length of a

- wall pier* (w_p) is the sheathed length of the *wall pier* adjacent to the opening.
- (d) The length of a *wall pier* (w_p) in a *Type I shear wall* with openings is not less than 24 inches (610 mm).

B5.2.1.2 Type II Shear Walls

- Type II shear walls* shall conform to the following requirements:
- (a) The height-to-length aspect ratio (h/w) of a *Type II shear wall segment* does not exceed the values in Tables B5.2.2.3-1 through B5.2.2.3-2.
- (b) For a *Type II shear wall*, the *nominal strength [resistance]* for shear, V_n , is based upon a screw spacing of not less than 4 inches (100 mm) on center.
- (c) Where horizontal out-of-plane offset irregularities occur in a *Type II shear wall*, portions of the wall on each side of the offset irregularity are designated as separate *Type II shear walls*.
- (d) *Collectors* for shear transfer are provided for the full length of the *Type II shear wall*.
- (e) *Type II shear walls* have uniform top-of-wall and bottom-of-wall elevations.
- (f) *Type II shear wall* height, h , does not exceed 20 feet (6.1 m).

B5.2.2 Nominal Strength [Resistance]

B5.2.2.1 Type I Shear Walls

The *nominal strength [resistance]* for shear, V_n , shall be determined in accordance with the following:

For $h/w \leq 2$,

$$V_n = v_n w \quad (\text{Eq. B5.2.2-1})$$

where

h = Height of the *shear wall*, ft. [m].

w = Length of the *shear wall*, ft. [m].

v_n = *Nominal strength [resistance]* per unit length as specified in Section B5.2.2.3, lbs./ft. [kN/m].

Where permitted in Tables B5.2.2.3-1, B5.2.2.3-2 and Section B5.2.2.3.2.1, the *nominal strength [resistance]* for shear, V_n , for height-to-length aspect ratios (h/w) greater than 2:1, but not exceeding 4:1, shall be determined in accordance with the following:

For $2 < h/w \leq 4$,

$$V_n = v_n w (2w/h) \quad (\text{Eq. B5.2.2-2})$$

B5.2.2.2 Type II Shear Walls

The *nominal strength [resistance]* for shear, V_n , shall be determined in accordance with the following:

$$V_n = C_a v_n \Sigma L_i \quad (\text{Eq. B5.2.2-3})$$

where

C_a = Shear resistance adjustment factor from Table B5.2.2.2-1. For intermediate values of opening height ratio and percentages of full-height sheathing, the shear resistance adjustment factors are permitted to be determined by interpolation.

v_n = Nominal strength [resistance] per unit length as specified in Section B5.2.2.3, lbs./ft. [kN/m].

ΣL_i = Sum of lengths of Type II shear wall segments, ft. [m].

The percent of full-height sheathing shall be calculated as the sum of lengths (ΣL_i) of Type II shear wall segments divided by the total length of the Type II shear wall including openings.

The maximum opening height ratio shall be calculated by dividing the maximum opening clear height by the shear wall height, h .

Table B5.2.2.2-1
Shear Resistance Adjustment Factor, C_a

	Maximum Opening Height Ratio				
	1/3	1/2	2/3	5/6	1
Percent Full-Height Sheathing	Shear Resistance Adjustment Factor				
10%	1.00	0.69	0.53	0.43	0.36
20%	1.00	0.71	0.56	0.45	0.38
30%	1.00	0.74	0.59	0.49	0.42
40%	1.00	0.77	0.63	0.53	0.45
50%	1.00	0.80	0.67	0.57	0.50
60%	1.00	0.83	0.71	0.63	0.56
70%	1.00	0.87	0.77	0.69	0.63
80%	1.00	0.91	0.83	0.77	0.71
90%	1.00	0.95	0.91	0.87	0.83
100%	1.00	1.00	1.00	1.00	1.00

B5.2.2.3 Nominal Strength [Resistance] per Unit Length

B5.2.2.3.1 General Requirements

Type I shear walls and Type II shear walls shall conform to the following requirements:

- Wall studs and track are ASTM A1003 Structural Grade 33 (Grade 230) Type H steel for members with a designation thickness of 33 and 43 mils, and ASTM A1003 Structural Grade 50 (Grade 340) Type H steel for members with a designation thickness equal to or greater than 54 mils.
- Studs are C-shape members with a minimum flange width of 1-5/8 in. (41.3 mm), minimum web depth of 3-1/2 in. (89 mm) and minimum edge stiffener of 3/8 in. (9.5 mm).
- Track has a minimum flange width of 1-1/4 in. (31.8 mm) and a minimum web depth of 3-1/2 in. (89 mm).
- Screws for structural members are a minimum No. 8 and are in accordance with ASTM C1513.
- Panels less than 12 inches (305 mm) wide are not used.
- Maximum stud spacing is 24 inches (610 mm) on center.
- All sheathing edges are attached to structural members or panel blocking, unless otherwise specified.
- Where used as panel blocking, flat strap is a minimum thickness of 33 mils with a minimum width of 1-1/2 inches (38.1 mm).

B5.2.2.3.2 Steel Sheet Sheathing

The *nominal strength [resistance]* per unit length for assemblies with *steel sheet sheathing* and *panel blocking* shall be as specified in Table B5.2.2.3-1 or determined in accordance with Section B5.2.2.3.2.1.

The *nominal strength [resistance]* per unit length for unblocked assemblies with panel edges overlapped and attached to each other with screw spacing as required for panel edges in lieu of *panel blocking* shall be as specified in Table B5.2.2.3-1 multiplied by 0.70.

Tabulated values in Table B5.2.2.3-1 shall be applicable for any *load* duration.

Systems tabulated in Table B5.2.2.3-1 shall conform to the following additional requirements:

- (a) *Steel sheet sheathing* has a minimum *designation thickness* as specified in Table B5.2.2.3-1 and complies with ASTM A1003 Structural Grade 33 (Grade 230) Type H.
- (b) In Canada, *steel sheet sheathing* is connected without horizontal joints.
- (c) Screws used to attach *steel sheets* are a minimum No. 8 and are in accordance with ASTM C1513.

B5.2.2.3.2.1 Effective Strip Method

The effective strip method is permitted to be used only in the United States and Mexico. The *nominal shear strength [resistance]* per unit length for assemblies with steel sheet sheathing shall be determined in accordance with the following:

$$V_n = \text{minimum}(1.23P_n \cos \alpha, 1.23w_e t F_y \cos \alpha) \quad (\text{Eq. B5.2.2.3.2.1-1})$$

where

P_n = Nominal shear strength [resistance] of screw *connections* within the effective strip width, W_e , on the steel sheet sheathing

α = Arctan(h/w) (Eq. B5.2.2.3.2.1-2)

t = Design thickness of steel sheet sheathing

F_y = Yield stress of steel sheet sheathing

$w_e = w_{\max}$ when $\lambda \leq 0.0819$ (Eq. B5.2.2.3.2.1-3)

$= \rho w_{\max}$ when $\lambda > 0.0819$ (Eq. B5.2.2.3.2.1-4)

where

$w_{\max} = w / \sin \alpha$ (Eq. B5.2.2.3.2.1-5)

$\rho = \frac{1 - 0.55(\lambda - 0.08)^{0.12}}{\lambda^{0.12}}$ (Eq. B5.2.2.3.2.1-6)

$\lambda = 1.736 \frac{\alpha_1 \alpha_2}{\beta_1 \beta_2 \beta_3^2 a}$ (Eq. B5.2.2.3.2.1-7)

where

$\alpha_1 = F_{\text{ush}}/45$ (For F_{ush} in ksi) (Eq. B5.2.2.3.2.1-8)

$= F_{\text{ush}}/310.3$ (For F_{ush} in MPa) (Eq. B5.2.2.3.2.1-9)

$\alpha_2 = F_{\text{uf}}/45$ (For F_{uf} in ksi) (Eq. B5.2.2.3.2.1-10)

$= F_{\text{uf}}/310.3$ (For F_{uf} in MPa) (Eq. B5.2.2.3.2.1-11)

$\beta_1 = t_{\text{sh}}/0.018$ (For t_{sh} in inches) (Eq. B5.2.2.3.2.1-12)

$$= t_{sh}/0.457 \quad (\text{For } t_{sh} \text{ in mm}) \quad (\text{Eq. B5.2.2.3.2.1-13})$$

$$\beta_2 = t_f/0.018 \quad (\text{For } t_f \text{ in inches}) \quad (\text{Eq. B5.2.2.3.2.1-14})$$

$$= t_f/0.457 \quad (\text{For } t_f \text{ in mm}) \quad (\text{Eq. B5.2.2.3.2.1-15})$$

$$\beta_3 = s/6 \quad (\text{For } s \text{ in inches}) \quad (\text{Eq. B5.2.2.3.2.1-16})$$

$$= s/152.4 \quad (\text{For } s \text{ in mm}) \quad (\text{Eq. B5.2.2.3.2.1-17})$$

F_{ush} = Tensile strength of steel sheet sheathing
 F_{uf} = Minimum tensile strength of framing materials
 T_{sh} = Design thickness of steel sheet sheathing
 T_f = Minimum design thicknesses of framing members
 s = Screw spacing on the panel edges
 a = Wall aspect ratio (h:w)
 $= h/w$ (Eq. B5.2.2.3.2.1-18)

B5.2.2.3.2.1.1 The effective strip method is permitted to be used within the following range of parameters:

- (a) Designation thickness of stud, track, and stud blocking: 33 mils (0.838 mm) to 54 mils (1.37 mm).
- (b) Designation thickness of steel sheet sheathing: 18 mils (0.457 mm) to 33 mils (0.838 mm).
- (c) Screw spacing at panel edges: 2 in. (50.8 mm) to 6 in. (152 mm).
- (d) Height-to-width aspect ratio (h:w): 1:1 to 4:1.
- (e) Sheathing screw shall be minimum No. 8.
- (f) Yield stress of steel sheet sheathing shall not be greater than 50 ksi (345 MPa).

See Section B5.2.2.1 for *Type I shear wall* height-to-length aspect ratios (h/w) greater than 2:1, but not exceeding 4:1, for additional requirements.

B5.2.2.3.3 Wood Structural Panel Sheathing

The *nominal strength [resistance]* per unit length for assemblies with *wood structural panel* sheathing and *panel blocking* shall be as specified in Table B5.2.2.3-2.

In the United States and Mexico, increases in the *nominal strengths [resistances]* in Table B5.2.2.3-2, as allowed by other standards, shall not be permitted.

Tabulated values in Table B5.2.2.3-2 shall be applicable for short-term *load* duration only (wind or seismic *loads*). In the United States and Mexico, for *loads* of normal or permanent load duration as defined by the AWC NDS, the values shall be multiplied by 0.63 (normal) or 0.56 (permanent). In Canada, for *loads* of permanent term *load* duration (dead), the values shall be multiplied by 0.56. For standard term *load* duration (snow and occupancy), the values shall be multiplied by 0.80. For other permanent and standard *load* combinations where the specified dead *load* is greater than the specified standard term *load*, the values shall be multiplied by a factor equal to $0.8 - 0.43 \log (D/ST) \geq 0.56$, where D = specified dead *load* and ST = specified standard term *load* based on snow or occupancy *loads* acting alone or in combination.

Systems tabulated in Table B5.2.2.3-2 shall conform to the following additional requirements:

- (a) *Wood structural panel* sheathing is manufactured using exterior glue and complies with the following, as applicable:

- (1) In the United States and Mexico, DOC PS 1 or PS 2.
 - (2) In Canada, CSA O121, O151 or CAN/CSA O325.0.
- (b) *Wood structural panels* are applied either parallel to or perpendicular to *studs*.
- (c) Screws used to attach *wood structural panels* are a minimum No. 8 with a minimum head diameter of 0.285 inch (7.24 mm) and are in accordance with ASTM C1513.

B5.2.2.3.4 Gypsum Board Panel Sheathing

The *nominal strength [resistance]* per unit length for assemblies with gypsum board panel sheathing and *panel blocking* shall be as specified in Table B5.2.2.3-3.

The *nominal strength [resistance]* per unit length for unblocked assemblies shall be as specified in Table B5.2.2.3-3 multiplied by 0.35.

Tabulated values in Table B5.2.2.3-3 shall be applicable for short-term *load* duration only (wind or seismic *loads*).

Systems tabulated in Table B5.2.2.3-3 shall conform to the following additional requirements:

- (a) Gypsum board panels comply with ASTM C1396/C1396M.
- (b) Gypsum board panels are applied perpendicular to *studs* with *panel blocking* behind the horizontal joint and with *stud blocking* between the first two end *studs*, at each end of the wall, or applied vertically with all edges attached to *structural members*.
- (c) Screws used to attach gypsum board are a minimum No. 6 and are in accordance with ASTM C954 or ASTM C1002, as applicable.

B5.2.2.3.5 Fiberboard Panel Sheathing

The *nominal strength [resistance]* per unit length for assemblies with *fiberboard* panel sheathing and *panel blocking* shall be as specified in Table B5.2.2.3-4.

Tabulated values in Table B5.2.2.3-4 shall be applicable for short-term *load* duration only (wind *loads* only).

Systems tabulated in Table B5.2.2.3-4 shall conform to the following additional requirements:

- (a) *Fiberboard* panels comply with ASTM C208.
- (b) *Fiberboard* is applied perpendicular to *studs* with *panel blocking* behind the horizontal joint and with *stud blocking* between the first two end *studs*, at each end of the wall, or applied vertically with all edges attached to *structural members*.
- (c) Screws used to attach *fiberboard* are a minimum No. 8 and are in accordance with ASTM C1513. Head style is selected to provide a flat bearing surface in contact with the sheathing with a head diameter not less than 0.43 inches (10.9 mm). Screws are driven so that their flat bearing surface is flush with the surface of the sheathing.

B5.2.2.3.6 Combined Systems

For a *Type I shear wall* sheathed with the same material and fastener spacing on opposite faces of the same wall, the *nominal strength [resistance]* of the complete wall based on Tables B5.2.2.3-1 through B5.2.2.3-4 shall be determined by adding the *nominal strength [resistance]* from the two opposite faces together.

For a *Type I shear wall* having more than a single sheathing material or fastener

spacing, the *nominal strength [resistance]* of the complete wall based on Tables B5.2.2.3-1 through B5.2.2.3-4 shall not be permitted to be determined by adding the *nominal strength [resistance]* from the different individual walls; rather, it shall be determined in accordance with the following:

- (a) For a *Type I shear wall* having more than a single sheathing material or fastener configuration along one face of the same wall line, the *nominal strength [resistance]* shall be taken either assuming the weaker (lower *nominal strength [resistance]*) material or fastener configuration exists for the entire length of the wall, or the stronger (higher *nominal strength [resistance]*) material or fastener configuration exists for its own length, whichever is greater.
- (b) In the United States and Mexico, for a *Type I shear wall* sheathed with 15/32 in. structural 1 sheathing (4-ply) or 7/16 in. rated sheathing (OSB) on one side with screw spacing at 6 inches (150 mm) o.c. edge and 12 inches (300 mm) o.c. field and with 1/2 in. gypsum board on the opposite side with screw spacing at 7 in. (178 mm) o.c. edge and 7 in. (178 mm) o.c. field, the *nominal strengths* in Table B5.2.2.3-2 are permitted to be increased by 30 percent.
- (c) For other cases of a *Type I shear wall* having more than a single sheathing material or fastener configuration on opposite faces of the wall, the *nominal strength [resistance]* shall be taken either assuming the weaker material or fastener configuration exists for both faces of the wall, or the stronger material or fastener configuration exists for its own face alone, whichever is greater.

Table B5.2.2.3-1
Unit Nominal Shear Strength [Resistance] (v_n)^{1, 2}
For Shear Walls with Steel Sheet Sheathing on One Side of Wall

United States and Mexico (Pounds Per Foot)								
Sheathing	Max. Aspect Ratio (h/w)	Fastener Spacing at Panel Edges/Field (inches)				Stud Blocking Required	Designation Thickness of Stud, Track and Blocking (mils)	Required Sheathing Screw Size
		6/12	4/12	3/12	2/12			
0.018" steel sheet	2:1	485	-	-	-	No	33 (min.)	8
0.027" steel sheet	4:1 ³	-	1,000	1085	1170	No	43 (min.)	8
	4:1 ³	645	710	780	845	No	33 (min.)	8
0.030" steel sheet	4:1 ³	795	960	1005	1055	No	33 (min.)	8
	4:1 ³	910	1015	1040	1070	No	43 (min.)	8
	4:1 ³	-	-	-	1355	Yes	43 (min.)	10
0.033" steel sheet	4:1 ³	1035	1145	1225	1300	No	33 (min.)	8
	4:1 ³	1055	1170	1235	1305	No	43 (min.)	8
	4:1 ³	-	-	-	1505	Yes	43 (min.)	10
	4:1 ³	-	-	-	1870	No	54 (min.)	8
	4:1 ³	-	-	-	2085	Yes	54 (min.)	10
Canada (kN/m)								
Sheathing	Max. Aspect Ratio (h/w)	Fastener Spacing at Panel Edges/Field (mm)				Stud Blocking Required	Designation Thickness of Stud, Track and Blocking (mils)	Required Sheathing Screw Size
		150/300	100/300	75/300	50/300			
0.46 mm steel sheet	2:1	4.1	-	-	-	No	33 (min)	8
	2:1	4.5	6.0	6.8	7.5	No	43 (min)	8
	2:1	7.4	9.7	11.6	13.5	Yes	43 (min)	8
0.68 mm steel sheet	2:1	6.5	7.2	7.9	8.7	No	33 (min)	8
0.76 mm steel sheet	4:1 ³	8.9	10.6	11.6	12.5	No	43 (min)	8
	2:1	11.7	14.3	-	-	Yes	43 (min)	8
	2:1	-	-	19.9	23.3	Yes	54 (min)	8
0.84 mm steel sheet	4:1 ³	10.7	12.0	13.0	14.0	No	43 (min)	8

1. For SI: 1" = 25.4 mm, 1 foot = 0.305 m, 1 lb = 4.45 N.

2. See Section B5.2.2.3.6 for requirements for sheathing applied to both sides of wall.

3. See Section B5.2.2.1 for Type I shear wall height-to-length aspect ratios (h/w) greater than 2:1, but not exceeding 4:1.

Table B5.2.2.3-2
Unit Nominal Shear Strength [Resistance] (v_n)^{1, 2}
For Shear Walls with Wood Structural Panel Sheathing on One Side of Wall

United States and Mexico (Pounds Per Foot)						
Sheathing	Maximum Aspect Ratio (h/w)	Fastener Spacing at Panel Edges/Field (inches)				Designation Thickness of Stud, Track and Blocking (mils)
		6/12	4/12	3/12	2/12	
15/32" structural 1 (4-ply)	2:1	1065	1410	1735	1910	43 (min.)
7/16" rated sheathing (OSB)	2:1	910	1410	1735	1910	33 (min.)
7/16" rated sheathing (OSB) oriented perpendicular to framing	2:1	1020	-	-	-	33 (min.)
7/16" rated sheathing (OSB)	4:1 ³	-	1025	1425	1825	33 (min.)
Canada (kN/m)						
Sheathing	Maximum Aspect Ratio (h/w)	Fastener Spacing at Panel Edges/Field (mm)			Designation Thickness of Stud, Track and Blocking (mils)	
		150/300	100/300	75/300		
9.5 mm CSP Sheathing	4:1 ³	8.5	11.8	14.2	43 (min.)	
12.5 mm CSP Sheathing	4:1 ³	9.5	13.0	19.4	43 (min.)	
12.5 mm DFP Sheathing	4:1 ³	11.6	17.2	22.1	43 (min.)	
9 mm OSB 2R24/W24	4:1 ³	9.6	14.3	18.2	43 (min.)	
11 mm OSB 1R24/2F16/W24	4:1 ³	9.9	14.6	18.5	43 (min.)	

1. For SI: 1" = 25.4 mm, 1 foot = 0.305 m, 1 lb = 4.45 N.

2. See Section B5.2.2.3.6 for requirements for sheathing applied to both sides of wall.

3. See Section B5.2.2.1 for Type I shear wall height-to-length aspect ratios (h/w) greater than 2:1, but not exceeding 4:1.

Table B5.2.2.3-3
Unit Nominal Shear Strength [Resistance] (v_n)^{1, 2}
For Shear Walls with Gypsum Board Panel Sheathing on One Side of Wall

United States and Mexico (Pounds Per Foot)						
Sheathing	Maximum Aspect Ratio (h/w)	Fastener Spacing at Panel Edges/Field (inches)				Designation Thickness of Stud, Track and Blocking (mils)
		8/12	4/12	7/7	4/4	
½" gypsum board	2:1	230	295	290	425	33 (min)
Canada (kN/m)						
Sheathing	Maximum Aspect Ratio (h/w)	Fastener Spacing at Panel Edges/Field (mm)			Designation Thickness of Stud, Track and Blocking (mils)	
		200/300	150/300	100/300		
12.5 mm gypsum board	2:1	2.7	3.1	3.4	33 (min)	

1. For SI: 1" = 25.4 mm, 1 foot = 0.305 m, 1 lb = 4.45 N.

2. See Section B5.2.2.3.6 for requirements for sheathing applied to both sides of wall.

Table B5.2.2.3-4
Unit Nominal Shear Strength [Resistance] (v_n)^{1, 2}
For Shear Walls with Fiberboard Panel Sheathing on One Side of Wall

United States and Mexico (Pounds Per Foot)						
Sheathing	Maximum Aspect Ratio (h/w)	Fastener Spacing at Panel Edges/Field (inches)			Designation Thickness of Stud, Track and Blocking (mils)	
		4/6	3/6	2/6		
½" fiberboard	1:1	425	615	670	33 (min)	
Canada (kN/m)						
Sheathing	Maximum Aspect Ratio (h/w)	Fastener Spacing at Panel Edges/Field (mm)			Designation Thickness of Stud, Track and Blocking (mils)	
		100/150	75/150	50/150		
12.5 mm fiberboard	1:1	5.0	7.2	7.8	33 (min)	

1. For SI: 1" = 25.4 mm, 1 foot = 0.305 m, 1 lb = 4.45 N.

2. See Section B5.2.2.3.6 for requirements for sheathing applied to both sides of wall.

B5.2.3 Available Strength [Factored Resistance]

The *available strength* [*factored resistance*] ($\phi_v V_n$ for LRFD and LSD or V_n/Ω_v for ASD) shall be determined from the *nominal strength* [*resistance*] using the applicable *safety factors* (Ω) or *resistance factors* (ϕ) given in this section in accordance with the applicable design method – *ASD, LRFD, or LSD* as follows:

$$\Omega_v = 2.00 \text{ for ASD}$$

$$\phi_v = 0.65 \text{ for LRFD}$$

$$\phi_v = 0.70 \text{ for LSD (except gypsum and fiberboard sheathed walls)}$$

$$\phi_v = 0.60 \text{ for LSD (gypsum and fiberboard sheathed walls)}$$

B5.2.4 Collectors and Anchorage

Design of *collectors* and anchorage for *shear walls* shall conform to the requirements of this section.

B5.2.4.1 Collectors and Anchorage for In-Plane Shear

Collectors and anchorage for in-plane shear shall be designed in accordance with this section.

B5.2.4.1.1 Type I Shear Walls

The unit shear force, v , transmitted into the top and out of the base of the *Type I shear wall* shall be determined in accordance with the following:

$$v = \frac{V}{L} \quad (\text{Eq. B5.2.4-1})$$

where

v = Unit shear force, plf [kN/m]

V = Shear force determined in accordance with applicable *ASD, LRFD or LSD load combinations* in *Type I shear wall*, lbs [kN]

L = Length of *Type I shear wall*, feet [m]

B5.2.4.1.2 Type II Shear Walls

The unit shear force, v , transmitted into the top and out of the base of the *Type II shear wall segments*, and into *collectors* connecting *Type II shear wall segments*, shall be determined in accordance with the following:

$$v = \frac{V}{C_a \sum L_i} \quad (\text{Eq. B5.2.4-2})$$

where

v = Unit shear force, plf [kN/m]

V = Shear force determined in accordance with applicable *ASD, LRFD or LSD load combinations* in *Type II shear wall*, lbs [kN]

C_a = Shear resistance adjustment factor from Table B5.2.2.2-1

$\sum L_i$ = Sum of Lengths of *Type II shear wall segments*, feet [m]

B5.2.4.2 Uplift Anchorage at Wall Ends

Uplift anchorage at *shear wall* ends shall be designed in accordance with this section.

B5.2.4.2.1 General

Where uplift anchorage resists the overturning load from the story or stories above, the anchorage shall be sized for the anchorage force resulting from the lateral forces at its level plus the story or stories above.

Hold-downs shall be designed to resist the sum of both *shear wall* overturning and roof uplift, as applicable.

Uplift anchorage forces are permitted to be reduced to account for dead load in accordance with the *applicable building code*.

B5.2.4.2.2 Type I Shear Walls

Anchorage for uplift forces due to overturning shall be provided at each end of the *Type I shear wall*. The uplift anchorage force contributed from each level shall be determined in accordance with the following:

$$C = \frac{Vh}{L} \quad (\text{Eq. B5.2.4-3})$$

where

C = Uplift anchorage force contributed from each level, lbs [kN]

V = Shear force determined in accordance with applicable *ASD, LRFD* or *LSD load combinations* in *Type I shear wall*, lbs [kN]

h = *Shear wall* height, feet [m]

L = Length of *Type I shear wall* including anchor offsets, feet [m]

B5.2.4.2.3 Type II Shear Walls

Anchorage for uplift forces due to overturning shall be provided at each end of the *Type II shear wall*. For each level, the uplift anchorage force contributed shall be determined in accordance with the following:

$$C = \frac{Vh}{C_a \sum L_i} \quad (\text{Eq. B5.2.4-4})$$

where

C = Uplift anchorage force contributed from each level, lbs [kN]

V = Shear force determined in accordance with applicable *ASD, LRFD* or *LSD load combinations* in *Type II shear wall*, lbs [kN]

h = *Shear wall* height, feet [m]

C_a = Shear resistance adjustment factor from Table B5.2.2.2-1

ΣL_i = Sum of lengths of *Type II shear wall segments*, feet [m]

B5.2.4.3 Uplift Anchorage Between Type II Shear Wall Ends

In addition to the requirements of Section B5.2.4.2, *Type II shear wall* bottom plates at full-height sheathing locations shall be anchored for a uniform uplift force equal to the unit shear force, *v*, determined in accordance with Section B5.2.4.1 plus any applicable roof uplift forces.

B5.2.5 Design Deflection

The deflection of a blocked *Type I shear wall* with *steel sheet sheathing* or *wood structural panel* sheathing shown in Tables B5.2.2.3-1 and B5.2.2.3-2 is permitted to be calculated in accordance with the following:

$$\delta = \frac{2vh^3}{3E_s A_c b} + \omega_1 \omega_2 \frac{vh}{\rho G t_{\text{sheathing}}} + \omega_1^{5/4} \omega_2 \omega_3 \omega_4 \left(\frac{v}{\beta} \right)^2 + \frac{h}{b} \delta_v \quad (\text{Eq. B5.2.5-1})$$

where

A_c = Gross cross-sectional area of *chord member*, in square inches (mm²)

b = Length of the *shear wall*, in inches (mm)

E_s = Modulus of elasticity of steel
= 29,500,000 psi (203,000 MPa)

G = Shear modulus of sheathing material, in pounds per square inch (MPa)

h = Wall height, in inches (mm)

s = Maximum fastener spacing at panel edges, in inches (mm)

$t_{\text{sheathing}}$ = Nominal panel thickness, in inches (mm)

t_{stud} = Framing designation thickness, in inches (mm)

v = Shear demand, in pounds per linear inch (N/mm)
= V/b

(Eq. B5.2.5-2)

V = Total lateral *load* applied to the *shear wall*, in pounds (N)

β = 67.5 for plywood other than Canadian Soft Plywood (CSP),
= 55 for OSB and CSP for U.S. Customary units (lb/in^{1.5})
= 2.35 for plywood other than CSP,
= 1.91 for OSB and CSP for SI units (N/mm^{1.5})

= 29.12($t_{\text{sheathing}}/0.018$) for sheet steel (for $t_{\text{sheathing}}$ in inches) (lb/in^{1.5})

(Eq. B5.2.5-3a)

= 1.01($t_{\text{sheathing}}/0.457$) for sheet steel (for $t_{\text{sheathing}}$ in mm) (N/mm^{1.5})

(Eq. B5.2.5-3b)

δ = Calculated deflection, in inches (mm)

δ_v = Vertical deformation of anchorage/attachment details, in inches (mm)

ρ = 1.85 for plywood other than CSP, 1.05 for OSB and CSP

= 0.075($t_{\text{sheathing}}/0.018$) for sheet steel (for $t_{\text{sheathing}}$ in inches)

(Eq. B5.2.5-4a)

= 0.075($t_{\text{sheathing}}/0.457$) for sheet steel (for $t_{\text{sheathing}}$ in mm)

(Eq. B5.2.5-4b)

ω_1 = $s/6$ (for s in inches) and $s/152.4$ (for s in mm)

(Eq. B5.2.5-5)

ω_2 = $0.033/t_{\text{stud}}$ (for t_{stud} in inches) and

(Eq. B5.2.5-6a)

= $0.838/t_{\text{stud}}$ (for t_{stud} in mm)

(Eq. B5.2.5-6b)

ω_3 = $\sqrt{\frac{(h/b)}{2}}$

(Eq. B5.2.5-7)

ω_4 = 1 for wood structural panels

= $\sqrt{\frac{33}{F_y}}$ (for F_y in ksi)

(Eq. B5.2.5-8a)

= $\sqrt{\frac{227.5}{F_y}}$ (for F_y in MPa) for sheet steel

(Eq. B5.2.5-8b)

The deflection of a *Type I shear wall* with gypsum panel sheathing or fiberboard sheathing or *Type II shear wall* shall be determined by principles of mechanics considering the deformation of the sheathing and its attachment, *chord studs* and *hold-downs*.

B5.3 Strap Braced Wall Design

Strap braced walls shall be designed in accordance with the requirements of this section and shall be installed in accordance with the requirements of Section C3.6.2.

User Note:

See Section A1.3 for applicability of this section to cold-formed steel structural members and connections in seismic force-resisting systems.

B5.3.1 General

The height-to-length aspect ratio of a *strap braced wall* shall not exceed 2:1 unless a *rational engineering analysis* is performed which includes joint flexibility and end moments in the design of the *chord studs*.

B5.3.2 Nominal Strength [Resistance]

The *nominal strength [resistance]* for the *strap, connections, and chord studs* shall be determined in accordance with AISI S100.

B5.3.3 Available Strength [Factored Resistance]

The *available strength [factored resistance]* for the *strap, connections, and chord studs* shall be determined in accordance with AISI S100.

B5.3.4 Collectors and Anchorage

Design of *collectors* and anchorage for *strap braced walls* shall conform to the requirements of this section.

B5.3.4.1 Collectors and Anchorage for In-Plane Shear

Collectors and anchorage shall be designed to transmit the shear force into the top and out of the base of the *strap braced wall*.

B5.3.4.2 Uplift Anchorage at Wall Ends

Where uplift anchorage resists the overturning load from the story or stories above, the anchorage shall be sized for the anchorage force at its level plus the anchorage force of the story or stories above.

Hold-downs shall be designed to resist the sum of both *strap braced wall* overturning and roof uplift, as applicable.

Uplift anchorage forces are permitted to be reduced to account for dead load in accordance with the *applicable building code*.

Anchorage for uplift forces due to overturning shall be provided at each end of the *strap braced wall*. Uplift anchorage and boundary chord forces shall be determined in accordance with the following:

$$C = \frac{Vh}{L} \quad (\text{Eq. B5.3.4.2-1})$$

where

C = Boundary chord force (tension/compression), lbs [kN]

V = Shear force determined in accordance with applicable *ASD, LRFD or LSD load combinations* in *strap braced wall*, lbs [kN]

h = *Strap braced wall height*, feet [m]

L = *Length of strap braced wall including anchor offsets*, feet [m]

B5.3.5 Design Deflection

The deflection of a *strap braced wall* shall be determined by principles of mechanics considering the deformation of the *strap*, *chord studs* and *hold-downs*.

B5.4 Diaphragm Design

Diaphragms shall be designed based on principles of mechanics in accordance with Section B1.2.6 or tests in accordance with Section B5.4.5. Alternatively, in the United States and Mexico, *diaphragms* sheathed with *wood structural panels* are permitted to be designed as either blocked *diaphragms* or unblocked *diaphragms* in accordance with the requirements of Sections B5.4.1 through B5.4.4 and shall be installed in accordance with the requirements of Section C3.6.3.

B5.4.1 General

Diaphragms shall conform to the following requirements:

- (a) The aspect ratio (length/width) of the *diaphragm* does not exceed 4:1 for blocked *diaphragms* and 3:1 for unblocked *diaphragms*.
- (b) *Joists* and *track* are ASTM A1003 Structural Grade 33 (Grade 230) Type H steel for members with a *designation thickness* of 33 and 43 mils, and ASTM A1003 Structural Grade 50 (Grade 340) Type H steel for members with a *designation thickness* equal to or greater than 54 mils.
- (c) The minimum *designation thickness* of *structural members* is 33 mils.
- (d) *Joists* are C-shape members with a minimum *flange* width of 1-5/8 in. (41.3 mm), minimum *web* depth of 3-1/2 in. (89 mm) and minimum *edge stiffener* of 3/8 in. (9.5 mm).
- (e) *Track* has a minimum *flange* width of 1-1/4 in. (31.8 mm) and a minimum *web* depth of 3-1/2 in. (89 mm).
- (f) Screws for *structural members* are a minimum No. 8 and are in accordance with ASTM C1513.
- (g) *Wood structural panel* sheathing is manufactured using exterior glue and complies with DOC PS 1 or PS 2.
- (h) Screws used to attach *wood structural panels* are minimum No. 8 where *structural members* have a *designation thickness* of 54 mils or less and No. 10 where *structural members* have a *designation thickness* greater than 54 mils and are in accordance with ASTM C1513.
- (i) Screws in the field of the panel are attached to intermediate supports at a maximum 12-inch (305 mm) spacing along the *structural members*.
- (j) Panels less than 12 inches (305 mm) wide are not used.
- (k) Maximum *joist* spacing is 24 inches (610 mm) on center.
- (l) Where *diaphragms* are designed as blocked, all panel edges are attached to *structural members* or *panel blocking*.
- (m) Where used as *panel blocking*, flat *strap* is a minimum thickness of 33 mils with a minimum width of 1-1/2 inches (38.1 mm).

B5.4.2 Nominal Strength

The *nominal strength* per unit length for blocked and unblocked assemblies shall be as specified in Table B5.4.2-1.

Tabulated values in Table B5.4.2-1 are applicable for short-term load duration only (wind or seismic loads). For loads of normal or permanent load duration as defined by the AWC NDS, the values shall be multiplied by 0.75 (normal) or 0.67 (permanent).

Table B5.4.2-1
Nominal Shear Strength (R_n) per Unit Length for Diaphragms With Wood Structural Panel Sheathing¹

United States and Mexico (Pounds Per Foot)							
Sheathing	Thickness (in.)	Blocked				Unblocked	
		Screw spacing at diaphragm boundary edges and at all continuous panel edges (in.)				Screws spaced maximum of 6 in. on all supported edges	
		6	4	2.5	2	Load perpendicular to unblocked edges and continuous panel joints	All other configurations
		Screw spacing at all other panel edges (in.)					
6	6	4	3				
Structural I	3/8	768	1022	1660	2045	685	510
	7/16	768	1127	1800	2255	755	565
	15/32	925	1232	1970	2465	825	615
C-D, C-C and other graded wood structural panels	3/8	690	920	1470	1840	615	460
	7/16	760	1015	1620	2030	680	505
	15/32	832	1110	1770	2215	740	555

1. For SI: 1 in. = 25.4 mm, 1 foot = 0.305 m, 1 lb = 4.45 N.

B5.4.3 Available Strength

The *available strength* ($\phi_v V_n$ for LRFD or V_n/Ω_v for ASD) shall be determined from the *nominal strength* using the applicable *safety factors* (Ω) or *resistance factors* (ϕ) given in this section in accordance with the applicable design method – ASD or LRFD, as follows:

$$\Omega_v = 2.00 \text{ (ASD)}$$

$$\phi_v = 0.65 \text{ (LRFD)}$$

B5.4.4 Design Deflection

The deflection of a blocked *diaphragm* with *wood structural panel* sheathing shown in Table B5.4.2-1 is permitted to be calculated in accordance with Section B5.4.4.1. The deflection of an unblocked *diaphragm* with *wood structural panel* sheathing shown in Table B5.4.2-1 is permitted to be calculated in accordance with Section B5.4.4.2.

B5.4.4.1 Blocked Diaphragms

The deflection of a blocked *diaphragm*, δ_b , is permitted to be determined in accordance with the following:

$$\delta_b = \frac{0.052vL^3}{E_s A_c b} + \omega_1 \omega_2 \frac{vL}{\rho G t_{\text{sheathing}}} + \omega_1^{5/4} \omega_2 (\alpha) \left(\frac{v}{2\beta} \right)^2 + \frac{\sum_{j=1}^n \Delta_{ci} X_i}{2b} \quad (\text{Eq. B5.4.4-1})$$

where

A_c = Gross cross-sectional area of *chord member*, in square inches (mm²)

b = *Diaphragm* depth parallel to direction of *load*, in inches (mm)

E_s = Modulus of elasticity of steel

= 29,500,000 psi (203,000 MPa)

G = Shear modulus of sheathing material, in pounds per square inch (MPa)

L = *Diaphragm* length perpendicular to direction of *load*, in inches (mm)

n = Number of *chord* splices in *diaphragm* (considering both *diaphragm chords*)

s = Maximum fastener spacing at panel edges, in inches (mm)

$t_{\text{sheathing}}$ = Nominal panel thickness, in inches (mm)

t_{stud} = Nominal framing thickness, in inches (mm)

v = Shear demand, in pounds per linear inch (N/mm)

= $V/(2b)$

(Eq. B5.4.4-2)

V = Total lateral *load* applied to the *diaphragm*, in pounds (N)

X_i = Distance between the "*ith*" *chord*-splice and the nearest support, in inches (mm)

α = Ratio of the average *load* per fastener based on a non-uniform fastener pattern to the average *load* per fastener based on a uniform fastener pattern (= 1 for a uniformly fastened *diaphragm*)

β = 67.5 for plywood other than Canadian Soft Plywood (CSP)

= 55 for OSB and CSP for U.S. Customary units (lb/in^{1.5})

= 2.35 for plywood other than CSP

= 1.91 for OSB for SI units (N/mm^{1.5})

δ_b = Calculated deflection, in inches (mm)

Δ_{ci} = Deformation value associated with "*ith*" *chord* splice, in inches (mm)

ρ = 1.85 for plywood other than CSP

= 1.05 for OSB and CSP

ω_1 = $s/6$ (for s in inches)

(Eq. B5.4.4-3a)

= $s/152.4$ (for s in mm)

(Eq. B5.4.4-3b)

ω_2 = $0.033/t_{\text{stud}}$ (for t_{stud} in inches)

(Eq. B5.4.4-4a)

= $0.838/t_{\text{stud}}$ (for t_{stud} in mm)

(Eq. B5.4.4-4b)

B5.4.4.2 Unblocked Diaphragms

The deflection of an unblocked *diaphragm*, δ_{ub} , is permitted to be determined in accordance with the following:

$$\delta_{ub} = 2.50 \delta_b \quad (\text{Eq. B5.4.4-5})$$

where

δ_b = Deflection of blocked *diaphragm* determined in accordance with Eq. B5.4.4-1

B5.4.5 Beam Diaphragm Tests for Non-Steel Sheathed Assemblies

For buildings with the maximum aspect ratio of 4:1 and having *cold-formed steel* roof or floor assemblies having non-steel sheathing, the in-plane diaphragm *nominal shear strength [resistance]*, S_{nv} , shall be in accordance with Table B5.4.2-1 where applicable or shall be established by test in accordance with ASTM E455 and AISI S100 Section F1.1(a).

When the failure mode of the assembly is identified to be in the *cold-formed steel* members or sheathing-to-steel fasteners, *safety factors* shall not be less than and *resistance factors* shall not be greater than those prescribed by Section B5.2.3 when determined in accordance with the procedures of AISI S100 Section F1.1 with the following definitions of the variables:

β_o = Target reliability index

= 2.5 for USA and Mexico and

= 3.0 for Canada

F_m = Mean value of the fabrication factor

= 1.0

M_m = Mean value of the material factor

= 1.1

V_M = Coefficient of variation of material factor

= 0.10

V_F = Coefficient of variation of fabrication factor

= 0.10

V_Q = Coefficient of variation of the load effect

= 0.21

V_P = Actual calculated coefficient of variation of the test results, without limit

n = Number of connections in the assembly with the same tributary area

When the failure mode of the assembly is identified to be in the sheathing material, a *safety factor* of 2.8 and *resistance factor* of 0.6 shall be used.

C. INSTALLATION

C1 General

Structural members and connections shall be installed in accordance with the requirements of this section, as applicable.

C2 Material Condition

The following requirements shall apply to *structural members, connectors, hold-downs* and mechanical fasteners:

- (a) *Structural members, connectors, hold-downs* and mechanical fasteners shall be as specified by the *approved construction documents*.
- (b) Damaged *structural members, connectors, hold-downs* and mechanical fasteners shall be replaced or repaired in accordance with an *approved design* or as specified by a *registered design professional*.

C2.1 Web Holes

Holes in *webs* of framing members shall be in conformance with AISI S100 [CSA S136], the *approved construction documents*, or shall be reinforced or patched in accordance with an *approved design* as specified by a *registered design professional*.

C2.2 Cutting and Patching

C2.2.1 All cutting of framing members shall be done by sawing, abrasive cutting, shearing, plasma cutting or other *approved* methods acceptable to the *registered design professional*.

C2.2.2 Cutting or notching of *structural members*, including *flanges* and *lips* of *joists, studs, headers, rafters, and ceiling joists*, shall be permitted with an *approved design* or as specified by a *registered design professional*.

C2.2.3 Patching of cuts and notches shall be permitted with an *approved design* or as specified by a *registered design professional*.

C2.3 Splicing

Splicing of *joists, studs* and other *structural members* shall be permitted with an *approved design* or as specified by a *registered design professional*.

C3 Structural Framing

Structural members shall be installed in accordance with the requirements of this section, as applicable.

C3.1 Foundation

The foundation shall be level and free from defects beneath structural walls. If the foundation is not level, provisions shall be made to provide a uniform bearing surface with a maximum 1/4 inch (6.4 mm) gap between the bottom *track* or rim *track* and the foundation. This shall be accomplished through the use of load bearing shims or grout provided between the underside of the wall bottom *track* or rim *track* and the top of the foundation wall or slab at *stud* or *joist* locations.

C3.2 Ground Contact

Framing shall not be in direct contact with the ground unless permitted by an *approved* design. Framing not in direct contact with the ground shall be installed at a height above the ground in accordance with the *applicable building code*.

C3.3 Floors

C3.3.1 Plumbness and Levelness

Floor joists and *floor trusses* shall be installed plumb and level, except where designed as sloping members.

C3.3.2 Alignment

Floor joists and *floor trusses* shall comply with the in-line framing requirements of Section B1.2.3 and floor sheathing span capacity requirements of Section B1.2.4, as applicable.

C3.3.3 Bearing Width

Floor joists and *floor trusses* shall be installed with full bearing over the width of the bearing wall beneath, a minimum 1-1/2 inch (38 mm) bearing end, or in accordance with an *approved* design or as specified by a *registered design professional*.

C3.3.4 Web Separation

Floor joist webs shall not be in direct contact with *rim track webs*.

C3.4 Walls

C3.4.1 Straightness, Plumbness and Levelness

Wall *studs* shall be installed plumb and walls shall be level in accordance with ASTM C1007, except where designed as sloping members.

C3.4.2 Alignment

Structural wall *studs* shall comply with the in-line framing requirements of Section B1.2.3 and wall sheathing span capacity requirements of Section B1.2.4, as applicable.

C3.4.3 Stud-to-Track Connection

The *connection* between the *stud flange* and the *track flange* shall meet the requirements of Section B3.2.5 and shall permit both ends of the wall *stud* to be connected to the *track* to restrain rotation about the longitudinal wall *stud* axis and horizontal displacement perpendicular to the wall *stud* axis. Further, the maximum gap between the end of the *stud* and the *track web* shall also comply with the following, as applicable:

- (a) Ends of axial load bearing wall *studs* 54 mils and less shall have square end cuts and shall be seated tight against the *track* with a gap that does not exceed 1/8 in. (3.2 mm) between the end of the wall framing member and the *web* of the *track*. For thicknesses of the *stud* or *track* greater than 54 mil (0.054 inches (1.37mm)), the maximum end gap shall be specified by the *registered design professional*.
- (b) Ends of *curtain wall studs* shall have square end cuts and shall be seated in the *track* with

a gap that does not exceed 1/4 in. (6.4 mm) between the end of the wall *stud* and the *web* of the *track*, unless otherwise accepted by a *registered design professional*.

C3.4.4 Back-to-Back and Box Headers

Back-to-back and box *headers* designed in accordance with this Standard shall be installed in accordance with Figures C3.4.4-1 and C3.4.4-2, respectively. For box *headers*, it is permitted to connect *track flanges* to the *webs* of *C-shape* sections using 1-inch (25.4 mm) fillet welds spaced at 24 inches (610 mm) on center in lieu of No. 8 screws.

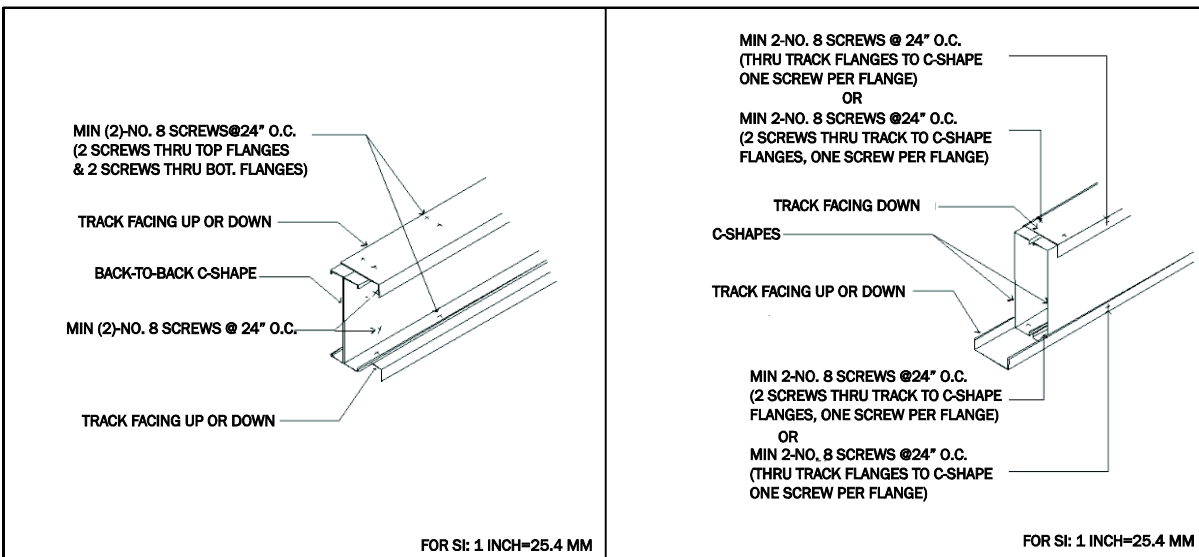

Figure C3.4.4-1 Back-to-Back Header

Figure C3.4.4-2 Box Header

C3.4.5 Double and Single L-Headers

Double and single *L-headers* designed in accordance with this Standard shall be installed in accordance with Figures C3.4.5-1 and C3.4.5-2, respectively.

C3.4.6 Inverted L-Header Assemblies

Inverted double or single *L-headers* designed in accordance with this Standard shall be installed in accordance with the following:

- (1) The horizontal leg of the inverted *L-header* shall be coped to permit the vertical leg to lap over at least one bearing *stud* at each end. The horizontal leg after coping shall be within 1/2 inch (12.7 mm) of the bearing *stud* at each end.
- (2) The horizontal leg of the inverted *L-header* shall be attached to the head *track* at each end and at 12 inches (304.8 mm) on center with minimum #8 screws.
- (3) The vertical leg of the inverted *L-header* shall be attached to at least one bearing *stud* at each end and each cripple *stud* with a minimum No. 8 screw top and bottom. The top screw in the vertical leg of the inverted *L-header* shall be located not more than 1 inch (25.4 mm) from the top edge of the vertical leg.

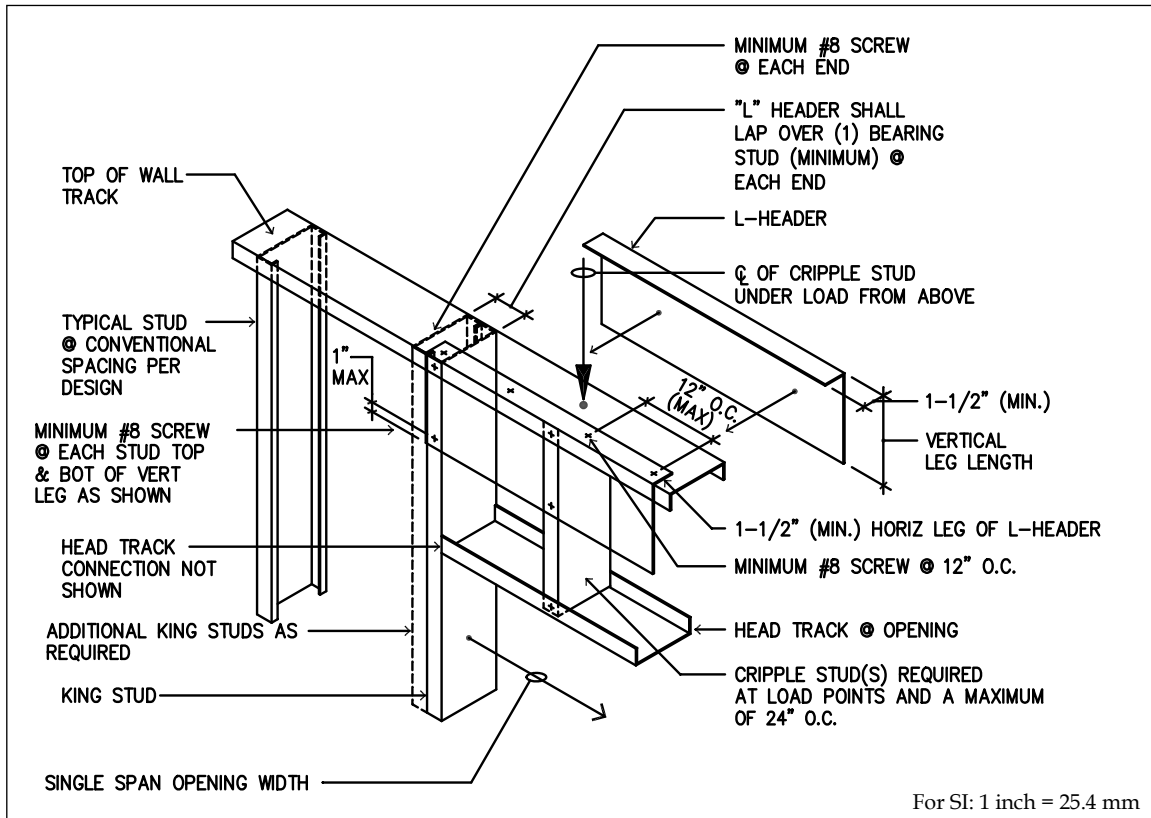

Figure C3.4.5-1 Double L-Header

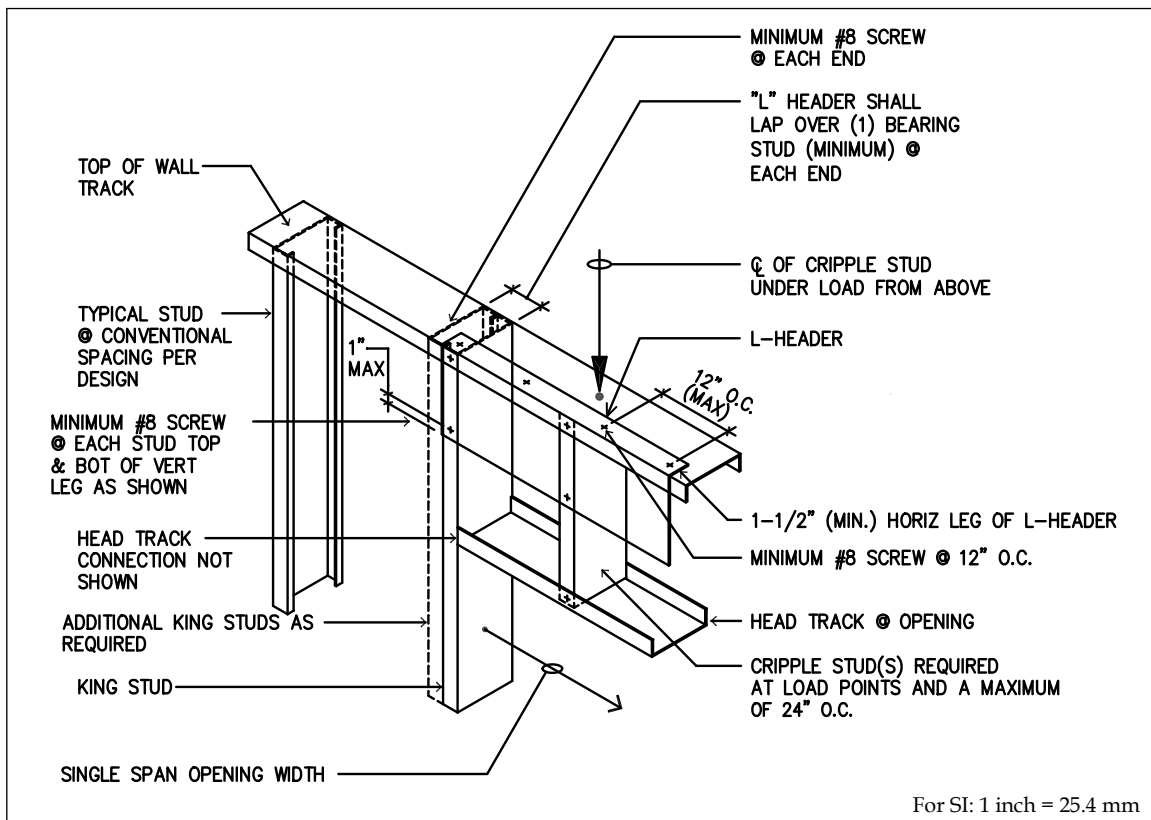

Figure C3.4.5-2 Single L-Header

C3.5 Roofs and Ceilings

C3.5.1 Plumbness and Levelness

Roof and ceiling framing members shall be installed plumb and level, except where designed as sloping members.

C3.5.2 Alignment

Roof and ceiling framing members shall comply with the in-line framing requirements of Section B1.2.3 and roof sheathing span capacity requirements of Section B1.2.4, as applicable.

C3.5.3 End Bearing

Ceiling joists and *roof trusses* shall be installed with full bearing over the width of the bearing wall beneath, or a minimum 1-1/2 inch (38 mm) bearing end condition, or in accordance with an *approved* design or as specified by a *registered design professional*.

C3.6 Lateral Force-Resisting Systems

C3.6.1 Shear Walls

The installation of *shear walls* designed in accordance with this Standard shall conform to the following requirements:

- (a) Fasteners along the edges in shear panels are placed from panel edges not less than the following, as applicable:
 - (1) In the United States and Mexico, 3/8 in. (9.5 mm).
 - (2) In Canada, 12.5 mm (1/2 in.).
- (b) Where used as *panel blocking* with *steel sheet sheathing*, *flat strap* is installed on top of or below the sheathing. Where used as *panel blocking* with other than *steel sheet sheathing*, *flat strap* is installed below the sheathing.
- (c) Where *panel blocking* is used with other than *steel sheet sheathing*, the screws are installed through the sheathing to the *panel blocking*.

C3.6.2 Strap Braced Walls

No additional provisions.

C3.6.3 Diaphragms

The installation of *diaphragms* sheathed with *wood structural panels* and designed in accordance with this Standard shall conform to the following requirements:

- (a) Fasteners along the edges in shear panels are placed from panel edges not less than 3/8 in. (9.5 mm).
- (b) Where used as *panel blocking*, *flat strap* is installed below the sheathing.
- (c) Where *panel blocking* is used, the screws are installed through the sheathing to the *panel blocking*.

C4 Connections

Connections shall be installed in accordance with the requirements of this section, as applicable.

C4.1 Screw Connections

C4.1.1 Steel-to-Steel Screws

Use of a larger-than-specified screw size is permitted if the installation is in accordance with the minimum design spacing and edge distance.

C4.1.2 Installation

C4.1.2.1 Screw fasteners shall extend through the steel *connection* with a minimum of three (3) exposed threads.

C4.1.2.2 Screw fasteners shall penetrate individual components of *connections* without causing permanent separation between components.

C4.1.3 Stripped Screws

C4.1.3.1 Stripped screw fasteners in direct tension shall not be considered effective.

C4.1.3.2 Stripped screw fasteners in shear shall only be considered effective when the number of stripped screw fasteners considered effective does not exceed 25% of the total number of screw fasteners considered effective in the *connection*.

C4.2 Welded Connections

Welded areas shall be protected with an *approved* treatment to retain the corrosion resistance of the welded area.

C5 Miscellaneous

Utilities and insulation shall be installed in accordance with the requirements of this section, as applicable.

C5.1 Utilities

C5.1.1 Holes

C5.1.1.1 Holes shall comply with the requirements specified in Section C2.1.

C5.1.1.2 Penetrations of floor, wall and ceiling/roof assemblies which are required to have a fire resistance rating shall be protected in accordance with the *approved construction documents*.

C5.1.2 Plumbing

All piping shall be provided with an isolative non-corrosive system to prevent galvanic action or abrasion between framing members and piping.

C5.1.3 Electrical

Wiring not enclosed in metal conduit shall be separated from the framing members by nonconductive, noncorrosive grommets or by other *approved* means.

C5.2 Insulation

C5.2.1 Mineral Fiber Insulation

Mineral fiber insulation (e.g., rock wool, glass fiber, etc.) for installation within cavities of framing members shall be full-width type insulation and shall be installed in accordance with the *applicable building code* and insulation manufacturer's requirements. Compression of the insulation is permitted to occur at the open side of the *C-shaped* framing member.

C5.2.2 Other Insulation

Other types of insulation (e.g., foams, loose fill, etc.) for installation within cavities of framing members shall be installed in accordance with the *applicable building code* and insulation manufacturer's requirements. The width of insulation shall be dimensionally compatible with the *cold-formed steel* framing.

D. QUALITY CONTROL AND QUALITY ASSURANCE

D1 General

D1.1 Scope and Limits of Applicability

Chapter D provides minimum requirements for *quality control* and *quality assurance* for material control, component manufacturing, and installation for *cold-formed steel light-frame construction*. Minimum observation and *inspection* tasks deemed necessary to ensure quality *cold-formed steel light-frame construction* are specified.

D1.2 Responsibilities

Quality control as specified in this chapter shall be provided by the *component manufacturer* and *installer*, as applicable. *Quality assurance* as specified in this chapter shall be provided by others where required by the *authority having jurisdiction*, the *applicable building code*, the *owner*, or the *registered design professional*.

D2 Quality Control Programs

D2.1 The *component manufacturer* shall establish and maintain *quality control* procedures and perform *inspections* to ensure that the work is in accordance with this Standard and the *shop drawings*.

D2.2 The *installer* shall establish and maintain *quality control* procedures and perform *inspections* to ensure that the work is in accordance with this Standard and the *construction documents*.

D2.3 Product identification shall comply with the requirements of Section A5.5, and shall be monitored by the *component manufacturer's* and *installer's quality control inspectors*, as applicable.

D2.4 Where part of a *component assembly*, the *component manufacturer's quality control inspector* shall perform *inspections* of the following items, as applicable:

- (a) *Cold-formed steel structural members* and *connectors* in accordance with Section D6.5.
- (b) Shop welding in accordance with Section D6.6.
- (c) Mechanical fastening in accordance with Section D6.7.

D2.5 The *installer's quality control inspector* shall perform *inspections* of the following, as applicable:

- (a) *Cold-formed steel structural members* and *connectors* that are not part of a *component assembly* in accordance with Section D6.5.
- (b) Field welding in accordance with Section D6.6.
- (c) Mechanical fastening that is not part of a *component assembly* in accordance with Section D6.7.
- (d) Installation of *cold-formed steel light-frame construction* in accordance with Section D6.8.
- (e) Installation of *cold-formed steel lateral force-resisting systems* in accordance with Section D6.9.
- (f) Damage to *cold-formed steel structural members* and *connectors*, including *component assemblies* damaged during or after delivery to the project.

D3 Quality Control Documents

D3.1 Documents to be Submitted

The *component manufacturer* and *installer* shall submit the following documents to the *registered design professional* and *contractor* for review prior to the installation of the *cold-formed steel light-frame construction*:

- (a) *Shop drawings*, unless *shop drawings* have been furnished by others.
- (b) *Installation drawings*, unless *installation drawings* have been furnished by others.
- (c) Product data sheets, catalogue data or independent evaluation reports on *cold-formed steel structural members*, including material, corrosion protection, *base steel thickness*, and dimensions. Alternatively, material, corrosion protection, *base steel thickness*, and dimensions shall be shown on the *installation drawings*.
- (d) Product data sheets, catalogue data or independent evaluation reports on *connectors* and mechanical fasteners.

D3.1.1 Additional Requirements for Lateral Force-Resisting Systems

D3.1.1.1 Component Assemblies

For *component assemblies*, the *component manufacturer* shall submit the following additional documents, as applicable, to the *registered design professional* and *contractor* for approval prior to the installation of the *cold-formed steel lateral force resisting system* elements:

- (a) Welding procedure specifications.
- (b) Mechanical fastener installation procedures.
- (c) Product data sheets, catalogue data or independent evaluation reports on *hold-downs*.

D3.1.1.2 Other Than Component Assemblies

For other than *component assemblies*, the *installer* shall submit the following additional documents, as applicable, to the *registered design professional* and *contractor* for approval prior to the installation of the *cold-formed steel lateral force-resisting system* elements:

- (a) Welding procedure specifications.
- (b) Mechanical fastener installation procedures.
- (c) Product data sheets, catalogue data or independent evaluation reports on *hold-downs*.

D3.1.1.3 Exceptions to Sections D3.1.1.1 and D3.1.1.2

The additional requirements in Section D3.1.1.1 and Section D3.1.1.2 are not required for *cold-formed steel lateral force-resisting systems* where either of the following apply:

- (a) The sheathing of the *shear wall* is gypsum board or *fiberboard*.
- (b) The sheathing is wood *structural sheathing* or *steel sheet* sheathing on only one side of the *shear wall* or *diaphragm* assembly and the fastener spacing of the sheathing is more than 4 inches (102 mm) on center (o.c.).

D3.2 Available Documents

Unless required for submittal by the *registered design professional*, the following documents, as applicable and upon request, shall be made available by the *component manufacturer* or *installer*,

as applicable, in electronic or printed form to the *registered design professional* and *contractor* for review prior to installation of the *cold-formed steel light-frame construction*:

- (a) Manufacturer's installation instructions for *connectors*, *hold-downs* and mechanical fasteners.
- (b) Manufacturer's product data sheets or catalog data for welding consumables, filler metals and fluxes that include the product, limitations of use, recommended or typical welding parameters, and storage and exposure requirements.
- (c) Welding procedure specifications.
- (d) Procedure qualification records for welding procedure specifications that are not prequalified in accordance with AWS D1.3, as applicable.
- (e) Welding personnel performance qualification records and continuity records.
- (f) *Component manufacturer's* and *installer's* written *quality control program(s)* that include material control procedures, *inspection* procedures, and nonconformance procedures.
- (g) *Component manufacturer's* and *installer's* *quality control inspector* qualifications.

D4 Quality Assurance Agency Documents

The agency responsible for *quality assurance* shall submit the following documents to the *authority having jurisdiction*, *registered design professional* and *owner*, as applicable:

- (a) *Quality assurance* agency's written practices for the monitoring and control of the agency's operations. The written practice shall include:
 - (1) The agency's procedures for the selection and administration of *inspection* personnel, describing the training, experience and examination requirements for qualification and certification of *inspection* personnel.
 - (2) The agency's *inspection* procedures, including general *inspection*, material controls, and visual welding *inspection*.
- (b) Qualifications of management designated for the project.
- (c) Qualification records for inspectors designated for the project.

D5 Inspection Personnel

D5.1 Quality Control Inspector

D5.1.1 A *quality control inspector* shall be designated as the person with overall responsibility for *quality control*. It is permitted to delegate specific quality control tasks to qualified personnel.

D5.1.2 *Quality control* welding *inspection* personnel shall be qualified in accordance with the *component manufacturer's* or *installer's* *quality control program*, as applicable, and in accordance with one of the following:

- (a) Associate Welding Inspector (AWI) or higher as defined in AWS B5.1.
- (b) Qualified by training or experience, or both, in *cold-formed steel light-frame construction* component manufacturing, installation, *inspection*, or testing and competent to perform *inspection* of the work.

D5.1.3 *Quality control* mechanical fastener *inspection* personnel shall be qualified in accordance with the *installer's* *quality control program* on the basis of training and experience in installation of similar fasteners and shall be competent to perform *inspection* of the work.

D5.2 Quality Assurance Inspector

D5.2.1 The *approved quality assurance inspector* shall be designated as the person with overall responsibility for *quality assurance*. The *approved quality assurance inspector* is permitted to delegate specific *quality assurance* tasks to qualified personnel.

D5.2.2 *Quality assurance welding inspection* personnel shall be qualified in accordance with the *quality assurance* agency's written practice and with either of the following:

- (a) Welding Inspector (WI) or higher as defined in AWS B5.1, except Associate Welding Inspectors (AWI) shall be permitted to be used under the direct supervision of WIs or higher who are on the premises and available when *weld inspection* is being conducted; or
- (b) Qualified by training or experience, or both, in *cold-formed steel light-frame construction* installation, *inspection* or testing and competent to perform *inspection* of the work.

D5.2.3 *Quality assurance mechanical fastener inspection* personnel shall be qualified in accordance with the *quality assurance* agency's written practice on the basis of training and experience in *inspection* of similar fasteners.

D6 Inspection Tasks

D6.1 General

Inspection tasks and documentation for *quality control* and *quality assurance* shall be in accordance with the tables in Sections D6.5, D6.6, D6.7, D6.8, and D6.9. These tables specify distinct *inspection* tasks as follows:

- (a) *Observe*. Observe shall mean to perform *inspection* of these items on an intermittent basis. Operations that do not interfere with the ability to perform *inspection* of these items need not be delayed pending these *inspections*. Frequency of observations shall be adequate to confirm that the work has been performed in accordance with the applicable documents.
- (b) *Perform*. Perform shall mean to execute these tasks prior to final acceptance for each item or element.
- (c) *Document*. Within the listed tasks, document shall mean the inspector shall prepare reports or other written documentation indicating that the work has or has not been performed in accordance with the *construction documents*.

D6.2 Quality Control Inspection Tasks

D6.2.1 *Quality control inspection* tasks shall be performed by the *component manufacturer's* or *installer's quality control inspector*, as applicable, in accordance with Sections D6.6 through D6.10. Tasks in the tables in Sections D6.5 through D6.9 listed for QC shall be those *inspections* performed by the *quality control inspector* to ensure that the work is performed in accordance with the *construction documents*.

D6.2.2 *Quality control inspection* shall utilize the following, as applicable: *construction documents, installation drawings, shop drawings, plans, specifications* or referenced standards.

D6.3 Quality Assurance Inspection Tasks

D6.3.1 *Quality assurance inspection* of the *component assemblies* shall be made at the *component manufacturer's* plant. The *quality assurance inspector* shall schedule this work to minimize interruptions to the work of the *component manufacturer*.

D6.3.2 *Quality assurance inspection of the cold-formed steel light-frame construction shall be made at the project site. The contractor shall schedule this work with the quality assurance inspector and the installer to minimize interruptions to the work of the installer.*

D6.3.3 *The quality assurance inspector shall review the materials test reports and certifications listed in Section D3.2 for compliance with the construction documents.*

D6.3.4 *Quality assurance tasks shall be performed by the quality assurance inspector, in accordance with Sections D6.5 through D6.9. Tasks in the tables in Sections D6.5 through D6.9 listed for QA shall be those inspections performed by the quality assurance inspector to ensure that the work is performed in accordance with the construction documents.*

D6.3.5 *Concurrent with the submittal of reports to the authority having jurisdiction, registered design professional and owner, as applicable, the quality assurance inspector shall submit to the contractor and the installer lists of nonconforming items.*

D6.4 Coordinated Inspection

D6.4.1 *Where a task is noted to be performed by both quality assurance and quality control, it is permitted to coordinate inspection function between the quality control inspector and quality assurance inspector so that the inspection functions are performed by only one party when approved in advance by the owner, registered design professional, and authority having jurisdiction.*

D6.4.2 *Where quality assurance tasks are performed only by the quality control inspector, each inspection shall be documented in a report and the quality assurance inspector shall periodically review the work of the quality control inspector at an interval acceptable to the owner, registered design professional, and authority having jurisdiction.*

D6.5 Material Verification

D6.5.1 *The component manufacturer's quality control inspector shall perform inspections of the cold-formed steel structural members and connectors used in component assemblies to verify compliance with the details shown on the shop drawings.*

D6.5.2 *The installer's quality control inspector shall perform inspections of the cold-formed steel structural members and connectors that are not part of a component assembly to verify compliance with the details shown on the installation drawings.*

D6.5.3 *The quality assurance inspector shall perform verifications and inspections, as applicable, to verify compliance with the construction documents and this Standard.*

D6.5.4 *Inspection tasks shall be in accordance with Tables D6.5-1 and D6.5-2.*

**Table D6.5-1
Material Verification Tasks
Prior to Assembly or Installation**

	Task	QC	QA
A	Verify compliance of <i>cold-formed steel structural members</i> : - Product identification (Section A5.5)	Perform	Perform
B	Verify compliance of <i>connectors</i>	Perform	Perform
C	Document acceptance or rejection of <i>cold-formed steel structural members and connectors</i>	Not Required ¹	Perform

¹ Documentation tasks for *quality control* should be as defined by the applicable *quality control program* of the *component manufacturer or installer*.

**Table D6.5-2
Material Verification Tasks
After Assembly or Installation**

	Task	QC	QA
A	Verify compliance of <i>cold-formed steel structural members</i> : - Product identification (Section A5.5)	Perform	Perform
B	Verify compliance of <i>connectors</i>	Perform	Perform
C	Document acceptance or rejection of <i>cold-formed steel structural members and connectors</i>	Not Required ¹	Perform

¹ Documentation tasks for *quality control* should be as defined by the applicable *quality control program* of the *component manufacturer or installer*.

D6.6 Inspection of Welding

D6.6.1 Observation of welding operations and visual *inspection* of in-process and completed welds shall be the primary method to confirm that the materials, procedures and workmanship are in conformance with the *construction documents* and AWS D1.3.

D6.6.2 Welding *inspection* tasks shall be in accordance with Tables D6.6-1, D6.6-2 and D6.6-3.

**Table D6.6-1
Inspection or Execution Tasks
Prior to Welding**

	Task	QC	QA
A	Welding procedure specifications available	Observe	Observe
B	Manufacturer certifications for welding consumables available	Observe	Observe
C	Material identification (type/grade)	Observe	Observe
D	Check welding equipment	Observe	Observe

**Table D6.6-2
Inspection or Execution Tasks
During Welding**

	Task	QC	QA
A	Use of qualified welders	Observe	Observe
B	Control and handling of welding consumables	Observe	Observe
C	Environmental conditions (wind speed, moisture, temperature)	Observe	Observe
D	Welding procedure specifications followed	Observe	Observe

**Table D6.6-3
Inspection or Execution Tasks
After Welding**

	Task	QC	QA
A	Verify compliance of welds	Perform	Perform
B	Welds meet visual acceptance criteria	Perform	Perform
C	Verify repair activities	Perform	Perform
D	Document acceptance or rejection of welded connections	Not Required ¹	Perform

¹ Documentation tasks for *quality control* should be as defined by the applicable *quality control program* of the component manufacturer or installer.

D6.7 Inspection of Mechanical Fastening

D6.7.1 Observation of mechanical fastening operations and visual *inspection* of in-process and completed connections shall be the primary method to confirm that the materials, procedures and workmanship are in conformance with the *construction documents* and manufacturer's installation instructions.

D6.7.2 Mechanical fastening *inspection* tasks shall be in accordance with Tables D6.7-1, D6.7-2 and D6.7-3.

**Table D6.7-1
Inspection or Execution Tasks
Prior to Mechanical Fastening**

	Task	QC	QA
A	Mechanical fastener manufacturer installation instructions available for mechanical fasteners	Observe	Observe
B	Proper tools available for mechanical fastener installation	Observe	Observe
C	Proper storage for mechanical fasteners	Observe	Observe

**Table D6.7-2
Inspection or Execution Tasks
During Mechanical Fastening**

	Task	QC	QA
A	Mechanical fasteners are positioned as required	Observe	Observe
B	Mechanical fasteners are installed in accordance with manufacturer's instructions	Observe	Observe

**Table D6.7-3
Inspection or Execution Tasks
After Mechanical Fastening**

	Task	QC	QA
A	Verify compliance of mechanical fasteners	Perform	Perform
B	Repair activities	Perform	Perform
C	Document acceptance or rejection of mechanically fastened connections	Not Required ¹	Perform

¹ Documentation tasks for *quality control* should be as defined by the applicable *quality control program* of the component manufacturer or installer.

D6.8 Inspection of Cold-Formed Steel Light-Frame Construction

D6.8.1 The component manufacturer's quality control inspector shall perform inspections of the component assemblies to verify compliance with the details shown on the shop drawings.

D6.8.2 The installer's quality control inspector shall perform inspections of the field-installed cold-formed steel structural members, component assemblies and connectors to verify compliance with the details shown on the installation drawings.

D6.8.3 The quality assurance inspector shall perform verifications and inspections, as applicable, to verify compliance with the construction documents.

D6.8.4 Inspection tasks shall be in accordance with Table D6.8-1.

**Table D6.8-1
Inspection or Execution Tasks
After Installation of Cold-Formed Steel Light-Frame Construction**

	Task	QC	QA
A	Verify compliance of cold-formed steel light-frame construction	Perform	Perform
B	Document acceptance or rejection of cold-formed steel light-frame construction	Not Required ¹	Perform

¹ Documentation tasks for *quality control* should be as defined by the applicable *quality control program* of the component manufacturer or installer.

D6.9 Additional Requirements for Lateral Force-Resisting Systems

Additional inspection tasks for cold-formed steel lateral force-resisting systems shall be in accordance with Tables D6.9-1 through D6.9-5.

Exception: The requirements in Section D6.9 are not required for cold-formed steel lateral force-resisting systems where either of the following apply:

- (a) The sheathing of the shear wall is gypsum board or fiberboard.
- (b) The sheathing is wood structural sheathing or steel sheet sheathing on only one side of

the *shear wall* or *diaphragm* assembly and the fastener spacing of the sheathing is more than 4 inches (102 mm) on center (o.c.).

D6.9.1 Fit-Up of Welds

In Table D6.9-2, following performance of the *inspection* task for 10 welds made by a given welder, with the welder demonstrating understanding of requirements and possession of skills, the Perform designation of this task shall be reduced to Observe.

Table D6.9-1
Additional Inspection or Execution Tasks
Prior to Installation of Cold-Formed Steel Lateral Force-Resisting Systems

	Task	QC	QA
A	Verify compliance of <i>shear wall</i> and <i>diaphragm</i> sheathing, <i>diagonal strap bracing</i> , and <i>hold-downs</i>	Perform	Perform
B	Document acceptance or rejection of <i>shear wall</i> and <i>diaphragm</i> sheathing, <i>diagonal strap bracing</i> , and <i>hold-downs</i>	Not Required ¹	Perform

¹ Documentation tasks for *quality control* should be as defined by the applicable *quality control program* of the component manufacturer or installer.

Table D6.9-2
Additional Inspection or Execution Tasks
Prior to Welding of Cold-Formed Steel Lateral Force-Resisting Systems

	Task	QC	QA
A	Welder identification system ¹	Observe	Observe
B	Fit-up of welds (alignment, gaps, condition of steel surfaces)	Perform/ Observe ²	Observe

¹ A system maintained by the *component manufacturer* or *installer*, as applicable, by which a welder who has welded a joint or member can be identified.

² See Section D6.9.1.

Table D6.9-3
Additional Inspection or Execution Tasks
Prior to Mechanical Fastening of Cold-Formed Steel Lateral Force-Resisting Systems

	Task	QC	QA
A	Proper fasteners selected	Observe	Observe
B	Proper installation procedure selected	Observe	Observe
C	Connecting elements meet applicable requirements	Observe	Observe

Table D6.9-4
Additional Inspection or Execution Tasks
During Mechanical Fastening of Cold-Formed Steel Lateral Force-Resisting Systems

	Task	QC	QA
A	For screw connections, joint brought tight (e.g., clamped) to avoid gaps between plies	Observe	Observe
B	For screw connections, tool adjusted to avoid stripped and overdriven fasteners	Observe	Observe
C	For post-installed connections to concrete, installation in accordance with manufacturer's instructions	Perform	Perform

Table D6.9-5
Additional Inspection or Execution Tasks
After Installation of Cold-Formed Steel Lateral Force-Resisting Systems

	Task	QC	QA
A	Verify compliance of <i>cold-formed steel lateral force-resisting system</i> installation	Perform	Perform
B	Document acceptance or rejection of installation of <i>cold-formed steel lateral force-resisting system</i>	Not Required ¹	Perform

¹ Documentation tasks for *quality control* should be as defined by the applicable *quality control program* of the *component manufacturer* or *installer*.

D7 Nonconforming Material and Workmanship

D7.1 Additional Inspections

In the event that observations determine that the materials and/or workmanship are not in conformance with the applicable documents, additional *inspections*, as specified by the *quality control program* or *registered design professional*, shall be performed to determine the extent of non-conformance.

D7.2 Rejection of Material

D7.2.1 Identification and rejection of materials and workmanship not in conformance with the *construction documents* is permitted at any time during progress of or following the completion of the work. However, this provision shall not relieve the *owner* or the inspector of the obligation for timely, in-sequence *inspections*.

D7.2.2 Nonconforming material and workmanship shall be brought to the immediate attention of the *contractor* and the *installer*.

D7.2.3 Nonconforming material or workmanship shall be brought into conformance, or made suitable for its intended purpose, as determined by the *registered design professional*.

E. TRUSSES

E1 General

Cold-formed steel trusses shall be designed in accordance with the requirements of this chapter, as applicable.

E1.1 Scope and Limits of Applicability

E1.1.1 Chapter E shall apply to design, manufacturing, quality criteria, installation and testing as they relate to the design of *cold-formed steel trusses*.

E1.1.2 The responsibilities specified in Section E2 are not intended to preclude alternate provisions as agreed upon by the parties involved.

E2 Truss Responsibilities

Truss responsibilities shall be in accordance with Section I1 of AISI S202.

E3 Loading

[Reserved]

E4 Truss Design

Except as modified or supplemented in this Standard, strength determinations shall be in accordance with AISI S100 [CSA S136].

E4.1 Materials

Sheet steel materials utilized in steel *truss* construction shall comply with ASTM A1003/A1003M Type H or ASTM A653/A653M Type SS, HSLAS, or HSLAS-F. *Cold-formed steel* welded tubing utilized in steel *truss* construction shall comply with ASTM A500.

E4.2 Corrosion Protection

Truss members, including *gusset plates*, shall have corrosion protection as required in accordance with Section A4.

E4.3 Analysis

In lieu of a *rational engineering analysis* to define joint flexibility, the following analysis modeling assumptions shall be used:

- (1) *Chord members* are continuous, except at the *heel*, *pitch breaks*, and *chord splices* where members are assumed to have pinned *connections*.
- (2) *Web members* are assumed to have pinned *connections* at each end.

Use of a specific joint stiffness other than the complete rotational freedom of a pin for a *connection* is permitted if the *connection* is designed for the forces resulting from a structural analysis with this specific joint stiffness.

E4.4 Member Design

E4.4.1 Properties of Sections

For *C-shapes* and other simple cross-section geometries, the properties of sections shall

be determined in accordance with conventional methods of structural design *rational engineering analysis*. Properties shall be based on full cross-section properties, except where use of a reduced cross-section or effective design width is required by AISI S100 [CSA S136]. For other cross-section geometries, properties shall be based on tests in accordance with Appendix 2.1.

E4.4.2 Compression Chord Members

The compression *chord member* shall be evaluated for axial *load* alone using Section C4 of AISI S100 [CSA S136], bending in accordance with Section C3.1 of AISI S100 [CSA S136], and combined axial *load* and bending in accordance with Section C5.2 of AISI S100 [CSA S136].

E4.4.2.1 For axial *load strength* [resistance] determination, the effective length, KL , shall be determined by *rational engineering analysis*, testing, or the following design assumptions as applicable:

- (a) For *C-shape chord members* with the x -axis as the axis of symmetry: L_x shall be equal to the distance between *panel points*, and C_m shall be taken as 0.85, unless an analysis is performed to justify another value. Where the *chord member* is continuous over at least one intermediate *panel point* and where sheathing is directly attached to the *chord member*, K_x shall be taken as 0.75. Otherwise, K_x shall be taken as unity. As an alternative, L_x shall be the distance between points of contraflexure with C_m and K_x taken as unity. Where sheathing is attached to the *chord member*, L_y shall be equal to the distance between sheathing connectors and K_y shall be taken as 0.75. Where purlins are attached to the *chord member*, L_y shall be the distance between purlins with K_y equal to unity. L_t shall be equal to the distance between *panel points*. Where the *chord member* is continuous over at least one intermediate *panel point* between the *heel* and *pitch break* and where sheathing is directly attached to the *chord member*, K_t shall be taken as 0.75. Otherwise, K_t shall be taken as unity. As an alternate, L_t shall be the distance between points of contraflexure with K_t taken as unity.

where

C_m = End moment coefficient in interaction formula

K_t = Effective length factor for torsion

K_x = Effective length factor for buckling about x -axis

K_y = Effective length factor for buckling about y -axis

L_t = Unbraced length of compression member for torsion

L_x = Unbraced length of compression member for bending about x -axis

L_y = Unbraced length of compression member for bending about y -axis

- (b) For *hat-shapes* with the x -axis as the axis of symmetry: Where sheathing is attached to the *chord member*, L_x shall be equal to the distance between sheathing connectors and K_x shall be taken as 0.75. Where purlins are attached to the *chord member*, L_x shall be the distance between purlins with K_x equal to unity. L_y shall be equal to the distance between *panel points*, and C_m shall be taken as 0.85, unless an analysis is performed to justify another value. Where the *chord member* is continuous over at least one intermediate *panel point* and

where sheathing is directly attached to the *chord member*, K_y shall be taken as 0.75. Otherwise, K_y shall be taken as unity. As an alternative, L_y shall be the distance between points of contraflexure with C_m and K_y taken as unity. L_t shall be equal to the distance between sheathing connectors or purlin spacing. Where the *chord member* is continuous over at least one intermediate *panel point* between the *heel* and *pitch break* and where sheathing is directly attached to the *chord member*, K_t shall be taken as 0.75. Otherwise, K_t shall be taken as unity. As an alternate, L_t shall be the distance between the points of contraflexure with K_t taken as unity.

- (c) For *Z-shapes* with the x-axis as out-of-the-plane of the *truss*: L_x shall be equal to the distance between *panel points*, and C_m shall be taken as 0.85, unless an analysis is performed to justify another value. Where the *chord member* is continuous over at least one intermediate *panel point* and where sheathing is directly attached to the *chord member*, K_x shall be taken as 0.75. Otherwise, K_x shall be taken as unity. As an alternative, L_x shall be the distance between points of contraflexure with C_m and K_x taken as unity. Where sheathing is attached to the *chord member*, L_y shall be equal to the distance between sheathing connectors and K_y shall be taken as 0.75. Where purlins are attached to the *chord member*, L_y shall be the distance between purlins with K_y equal to unity. Where the *chord member* depth is less than 6 inches, L_t shall be equal to the distance between sheathing connectors or purlin spacing. For *Z-shapes* where the *chord member* depth is greater than or equal to 6 inches, L_t shall be equal to the distance between *panel points*. Where the *chord member* is continuous over at least one intermediate *panel point* between the *heel* and *pitch break* and where sheathing is directly attached to the *chord member*, K_t shall be taken as 0.75. Otherwise, K_t shall be taken as unity. As an alternative, L_t shall be equal to the distance between points of contraflexure with K_t taken as unity.

E4.4.2.2 For bending strength [resistance] determination, the effective length, KL , shall be determined by *rational engineering analysis*, testing, or the following design assumptions as applicable:

- (a) Where sheathing is attached to the compression *flange*, $M_n = S_e F_y$ in accordance with Section C3.1.1 of AISI S100 [CSA S136].
- (b) Where purlins are attached to the compression *flange* between *panel points*, $M_n = S_c F_c$ in accordance with Section C3.1.2.1 of AISI S100 [CSA S136] with KL_y and KL_t for *C-shapes* and *Z-shapes* determined in accordance with E4.4.2.1 and KL_x and KL_t for *hat-shapes* taken as the distance between purlins.
- (c) Where sheathing or purlins are attached to the tension *flange* and the compression *flange* is laterally unbraced, $M_n = S_c F_c$ in accordance with Section C3.1.2.1 of AISI S100 [CSA S136]. For continuous span *chord members*, M_n in the region of the *panel point* shall be determined with KL_y and KL_t for *C-shapes* and *Z-shapes* determined in accordance with E4.4.2.1 and KL_x and KL_t for *hat-shapes* taken as the distance between the *panel point* and the point of contraflexure, and C_b shall be taken as unity. For simple and continuous span *chord members*, M_n in the mid-span region shall be determined with the effective length taken as the

distance between *panel points* and C_b shall be computed in accordance with Section C3.1.2.1 of AISI S100 [CSA S136].

where

C_b = Bending coefficient dependent on moment gradient

F_c = Critical buckling stress

F_y = Yield strength used for design

K_t = Effective length factor for torsion

K_x = Effective length factor for buckling about x-axis

K_y = Effective length factor for buckling about y-axis

L_t = Unbraced length of compression member for torsion

L_x = Unbraced length of compression member for bending about x-axis

L_y = Unbraced length of compression member for bending about y-axis

M_n = Nominal flexural strength [resistance]

S_c = Elastic section modulus of effective section calculated relative to extreme compression fiber at F_c

S_e = Elastic section modulus of effective section calculated relative to extreme compression fiber at F_y

E4.4.2.3 When a *C-shaped* section compression chord member is subject to concentrated load at a *panel point*, the interaction of axial compression, bending and web crippling shall be determined in accordance with the following:

For ASD:

$$\frac{P}{P_{no}} + \frac{M}{M_{nxo}} + \frac{R}{R_n} \leq \frac{1.49}{\Omega} \quad (\text{Eq. E4.4.2.3-1})$$

where

P = Required compressive axial strength

M_x = Required flexural strength

R = Required concentrated load strength

P_{no} = Nominal axial strength determined at $f = F_y$

M_{nxo} = Nominal flexural strength determined at $f = F_y$

R_n = Nominal interior one-flange web crippling strength

Ω = 1.95

For LRFD and LSD:

$$\frac{\bar{P}}{P_{no}} + \frac{\bar{M}_x}{M_{nxo}} + \frac{\bar{R}}{R_n} \leq 1.49\phi \quad (\text{Eq. E4.4.2.3-2})$$

where

\bar{P} = Required compressive axial strength [axial force of factored loads]

\bar{M}_x = Required flexural strength [moment of factored loads]

\bar{R} = Required concentrated load strength [factored concentrated load]

P_{no} = Nominal axial strength [resistance] determined at $f = F_y$

M_{nxo} = Nominal flexural strength [resistance] determined at $f = F_y$

R_n = Nominal interior one-flange loading web crippling strength [resistance]

ϕ = 0.85 for LRFD

= 0.80 for LSD

E4.4.3 Tension Chord Members

The tension *chord member* shall be evaluated for axial *load* in accordance with Section C2 of AISI S100 [CSA S136], bending in accordance with Section C3.1 of AISI S100 [CSA S136], and combined axial *load* and bending in accordance with Section C5.1 of AISI S100 [CSA S136]. The axial *load* is permitted to be taken as acting through the centroid of the section.

E4.4.4 Compression Web Members

Compression *web members* shall be evaluated for axial *load* alone using Section C4 of AISI S100 [CSA S136] and combined axial *load* and bending using Section C5.2 of AISI S100 [CSA S136], and the requirements of this section, as applicable.

E4.4.4.1 For a *C-shaped* compression *web member* that is attached at each end through its *web* element back-to-back with the *web* of a *C-shaped chord member* and is not subjected to applied *loads* between its ends, the interaction of axial compression and out-of-plane bending shall be determined in accordance with the following interaction equation:

For ASD:

$$\frac{\Omega_c R_P}{P_n} + \frac{\Omega_b C_{my} R_{Pe}}{M_{ny} \alpha_y} \leq 1.0 \quad (\text{Eq. E4.4.4-1})$$

For LRFD and LSD:

$$\frac{R\bar{P}}{\phi_c P_n} + \frac{C_{my} R\bar{P}e}{\phi_b M_{ny} \alpha_y} \leq 1.0 \quad (\text{Eq. E4.4.4-2})$$

where

$$R = -\left(\frac{L/r}{173}\right)^2 + \frac{L/r}{88} - 0.22 \geq 0.6 \quad (\text{Eq. E4.4.4-3})$$

L = Unbraced length of the compression *web member*

r = Radius of gyration of the full section about the minor axis

P_n = Nominal axial strength [resistance] based on Section C4.1 of AISI S100 [CSA S136]. Only flexural buckling need be considered.

e = Eccentricity of compression force with respect to the centroid of the full section of the *web member*

P, Ω_b, Ω_c, C_{my}, M_{ny}, \bar{P} , φ_c, φ_b and α_y shall be as determined in accordance with Section C5.2.1 (ASD) or C5.2.2 (LRFD and LSD) of AISI S100 [CSA S136].

When computing the *available strength [resistance]*, the effective lengths, K_xL_x, K_yL_y and K_tL_t shall be taken as the distance between the centers of the member's end *connection* patterns.

E4.4.4.2 For other compression *web members* that are concentrically loaded, the axial compression *load* is permitted to be taken as acting through the centroid of the section.

E4.4.4.3 For other compression *web members* that are not concentrically loaded, proper regard for eccentricity shall be considered.

E4.4.5 Tension Web Members

Tension *web members* shall be evaluated for axial *load* in accordance with Section C2 of

AISI S100 [CSA S136]. For tension *web members*, which are symmetrically loaded, the axial tension *load* is permitted to be taken as acting through the centroid of the section. For other tension members that are not symmetrically loaded, proper regard for eccentricity shall be considered.

E4.4.6 Eccentricity in Joints

E4.4.6.1 A *rational engineering analysis* using multiple nodes or an analysis using single node that includes proper regard for the effects of eccentricity shall be performed.

E4.4.6.2 *Chord member* shear and moments in joints shall include the following considerations:

- (a) Where the *web member* lap length is greater than or equal to 75% of the *chord member* depth, the *chord member* shall be investigated for combined bending and shear in accordance with Equation C3.3.1-2 (ASD) or Equation C3.3.2-2 (LRFD and LSD) of AISI S100 [CSA S136]. For *C-shaped* section *trusses* where screws are used as the connector, a minimum of four screws shall be used in the *web member* to *chord member* connection and the screws shall be uniformly distributed in the lapped area.
- (b) Where the *web member* lap length is less than 75% of the *chord member* depth, the *chord member* shall be investigated for combined bending and shear in accordance with Equation C3.3.1-1 (ASD) or C3.3.2-1 (LRFD and LSD) of AISI S100 [CSA S136].

E4.4.6.3 Along the length of the *chord member*, at the mid-point between the intersecting *web members* at a joint, shear shall be evaluated by Section C3.2 of AISI S100 [CSA S136]. The shear buckling coefficient shall be based on either Equation C3.2.1-6 or C3.2.1-7 with “a” taken as the smaller of the distance between the fastener groups, or center-to-center of the *web members*.

E4.5 Gusset Plate Design

E4.5.1 The *nominal* axial compressive strength [resistance], P_n , of thin, flat *gusset plates* shall be calculated as follows:

$$P_n = R_g b t F_y \quad (\text{Eq. E4.5-1})$$

where

$$R_g = \begin{cases} 0.47 \frac{W_{\min}}{L_{\text{eff}}} + 0.3 & \text{where } \frac{W_{\min}}{L_{\text{eff}}} \leq 1.5 \\ = 1.0 & \text{where } \frac{W_{\min}}{L_{\text{eff}}} > 1.5 \end{cases} \quad (\text{Eq. E4.5-2})$$

b = Effective width determined in accordance with Section B2.1 of AISI S100 [CSA S136] with $f=F_y$, $k=4$ and $w=W_{\min}$

F_y = Specified minimum *yield strength*

t = *Design thickness* of *gusset plate*

Ω_c = 2.50 for ASD

ϕ_c = 0.60 for LRFD

= 0.50 for LSD

W_{\min} shall be taken as the lesser of the actual *gusset plate* width or Whitmore section, which shall be determined using a spread-out angle of 30° along both sides of the

connection, beginning at the first row of fasteners in the *connection*. L_{eff} shall be taken as the average length between the last rows of fasteners of adjacent *truss* members in the *connection*.

Equation E4.5-1 shall be valid for the range of parameters listed in Table E4.5-1.

Table E4.5-1
Parameters for Equation E4.5-1

Parameter	Minimum	Maximum
Gusset Plate:		
Design Thickness	0.0566 inch (1.438 mm)	0.1017 inch (2.583 mm)
Design Yield Strength	33 ksi (228 MPa)	50 ksi (345 MPa)
W_{min} / L_{eff} Ratio	0.8	6.0
Chord Member-to-Gusset Plate Fastener Pattern	Two rows with two fasteners per row	n/a

E4.5.2 The *nominal* axial tensile strength [*resistance*] of thin, flat gusset plates shall be calculated in accordance with the requirements of Section C2 of AISI S100 [CSA S136].

E4.6 Connection Design

E4.6.1 Fastening Methods

Fastening systems shall be specified by the *truss designer*. Screw, bolt, and weld *connections* shall be designed in accordance with AISI S100 [CSA S136]. For *connections* using other fastener types, design values shall be determined by testing in accordance with Section F1 of AISI S100 [CSA S136].

Other fastening methods shall be in accordance with the manufacturer's requirements.

E4.6.2 Coped Connections for C-Shaped Sections

E4.6.2.1 Coping is permitted at *pitch break* and *heel connections* in accordance with the *truss* design and the following, as applicable:

- (a) At a coped *heel connection* with a coped *flange* and a *bearing stiffener* having a moment of inertia (I_{min}) greater than or equal to 0.161 in.⁴ (67,000 mm⁴), the *available shear strength* [*factored resistance*] shall be calculated in accordance with Section C3.2 of AISI S100 [CSA S136] and reduced by the following factor, R:

$$R = 0.976 - \frac{0.556c}{h} - \frac{0.532d_c}{h} \leq 1.0 \quad (\text{Eq. E4.6.2-1})$$

where

c = Length of cope

d_c = Depth of cope

h = Flat width of *web* of section being coped

I_{min} = Moment of inertia determined with respect to an axis parallel to the *web* of the *chord member*

t = *Design thickness* of section being coped

- (b) At a coped *heel connection* with a coped *flange* where a *bearing stiffener* having a moment of inertia (I_{min}) less than 0.161 in.⁴ (67,000 mm⁴), the strength at the *heel*

is governed by web crippling determined in accordance with Section C3.4 of AISI S100 [CSA S136] and reduced by the following factor, R:

$$R = 1.036 - \frac{0.668c}{h} - \frac{0.0505d_c}{h} \leq 1.0 \quad (\text{Eq. E4.6.2-2})$$

E4.6.2.2 Equations E4.6.2-1 and E4.6.2-2 shall be applicable within the following limitations:

$$\begin{aligned} h/t &\leq 200, \\ 0.10 &< c/h < 1.0, \text{ and} \\ 0.10 &< d_c/h < 0.4 \end{aligned}$$

E4.7 Serviceability

Serviceability requirements, as specified in AISI S100 [CSA S136], shall be determined by the *building designer* or *applicable building code*. When computing *truss* deflections, it is permitted to use the full cross-sectional area of the *truss* members.

E5 Quality Criteria for Steel Trusses

Section E5 applies to the manufacture of *cold-formed steel trusses*.

E5.1 Manufacturing Quality Criteria

The *truss manufacturer* shall manufacture the *trusses* in accordance with the final *truss design drawings*, using the quality criteria required by the manufacturer's quality control program unless more stringent quality criteria are required by the owner in writing or through the *construction documents*.

E5.2 Member Identification

Truss chord members and *web members* shall be identified in accordance with the product identification requirements for framing members defined in Section A5.5.

E5.3 Assembly

E5.3.1 *Trusses* shall have steel members that are accurately cut, in accordance with the *truss* design, so that the assembled *truss* is made by close-fitting steel members.

E5.3.2 The maximum gap between *web members* shall not exceed 1/2 inch (12.7 mm) unless specified or accepted by the *truss design engineer* or *truss designer*.

E5.3.3 The location of *chord members*, *web members*, and joints shall be as specified in the *truss* design.

E5.3.4 *Truss* dimensions which vary from the *truss* design shall not exceed the tolerances shown in Table E5.8. Inaccuracies exceeding these allowable tolerances shall be acceptable upon approval and follow-up documentation by the *truss design engineer* or *truss designer*.

E5.3.5 Any shop modifications or repairs shall be documented by the *truss design engineer* or *truss designer*.

Table E5.5-1
Manufacturing Tolerances for Finished Truss Units

Length ¹	Variance from Design Dimensions
Up to 30 feet (9.14 m)	½ inch (12.7 mm)
Over 30 feet (9.14 m)	¾ inch (19.1 mm)
Height ²	Variance from Design Dimensions
Up to 5 feet (1.52 m)	¼ inch (6.4 mm)
Over 5 feet (1.52 m)	½ inch (12.7 mm)

¹ Length, for manufacturing tolerance purposes, is the overall length of the *truss* unit, excluding overhangs and extensions.

² Height, for manufacturing tolerance purpose, is the overall height of the *truss* unit measured from the top of the top *chord member* to the bottom of the bottom *chord member* at the highest point of the *truss*, excluding projections above the top *chord member* and below the bottom *chord member*, overhangs, and extensions.

E6 Truss Installation

Section E6 applies to installation of *cold-formed steel trusses*.

E6.1 Installation Tolerances

E6.1.1 Straightness

Trusses shall not be installed with an overall bow or bow in any *chord member* or panel which exceeds the lesser of $L/200$ or 2 inches (50.8 mm), where L is the length of the *truss*, *chord member*, or panel in inches.

E6.1.2 Plumbness

Trusses shall not be installed with a variation from plumb (vertical tolerance) at any point along the length of the *truss* from top to bottom which exceeds $1/50$ of the depth of the *truss* at that point or 2 inches (50.8 mm), whichever is less, unless *trusses* are specifically designed to be installed out of plumb.

E6.1.3 Top Chord Bearing Trusses

For top *chord bearing trusses*, a maximum gap tolerance between the inside of the bearing and the first diagonal or vertical *web member* shall be specified in the design.

E7 Test-Based Design

Tests, when required as defined below, shall be conducted under the supervision of a *registered design professional* in accordance with the following:

- For *cold-formed steel truss* components (*chord members* and *web members*) for which the *nominal strength [resistance]* cannot be determined in accordance with this Standard or its reference documents, performance tests shall be performed in accordance with Appendix 2.1.
- For *cold-formed steel truss connections* for which the *nominal strength [resistance]* cannot be determined in accordance with this Standard or its reference documents, performance tests shall be performed in accordance with AISI S905.
- For *cold-formed steel trusses* for which the *nominal strength [resistance]* can be determined in accordance with this Standard and its reference documents or determined on the basis of

component performance tests in accordance with Appendix 2.1, and when it must be demonstrated that the strength [*resistance*] is not less than the *nominal strength* [*resistance*] specified in this Standard or its reference documents, confirmatory tests shall be performed in accordance with Appendix 2.2.

- (d) For *cold-formed steel trusses* for which the *nominal strength* [*resistance*] cannot be determined in accordance with this Standard and its reference documents or determined on the basis of component performance tests in accordance with Appendix 2.1, performance tests shall be performed in accordance with Appendix 2.3.

F. TESTING

F1 General

Tests, when required to determine the strength, flexibility or stiffness of *cold-formed steel structural members or connections*, shall be in accordance with *approved* test methods and Section F1 of AISI S100 [CSA S136], and shall be conducted under the supervision of a *design professional*.

The following test standards are permitted to be used to determine the strength, flexibility or stiffness of *cold-formed steel structural members and connections* via testing:

1. AISI S901, *Rotational-Lateral Stiffness Test Method for Beam-to-Panel Assemblies*
2. AISI S902, *Stub-Column Test Method for Effective Area of Cold-Formed Steel Columns*
3. AISI S903, *Standard Methods for Determination of Uniform and Local Ductility*
4. AISI S904, *Standard Test Methods for Determining the Tensile and Shear Strength of Screws*
5. AISI S905, *Test Standard for Cold-Formed Steel Connections*
6. AISI S907, *Test Standard for Cantilever Test Method for Cold-Formed Steel Diaphragms*
7. AISI S909, *Standard Test Method for Determining the Web Crippling Strength of Cold-Formed Steel Beams*
8. AISI S910, *Test Method for Distortional Buckling of Cold-Formed Steel Hat-Shaped Compression Members*
9. AISI S911, *Method for Flexural Testing for Cold-Formed Steel Hat-Shaped Beams*
10. AISI S913, *Test Standard for Hold-Downs Attached to Cold-Formed Steel Structural Framing*
11. AISI S914, *Test Standard for Joist Connectors Attached to Cold-Formed Steel Structural Framing*
12. AISI S915, *Test Standard for Through-The-Web Punchout Cold-Formed Steel Wall Stud Bridging Connectors*

F2 Truss Components and Assemblies

Tests of *cold-formed steel truss* components and assemblies, when required in Chapter E, shall be in accordance with Appendix 2 or other *approved* test methods and Section F1 of AISI S100 [CSA S136], and shall be conducted under the supervision of a *design professional*.

APPENDIX 1, CONTINUOUSLY BRACED DESIGN FOR DISTORTIONAL BUCKLING RESISTANCE

- 1.1** Calculation of the *nominal* distortional buckling strength [resistance] in flexure in accordance with Section C3.1.4 of AISI S100 [CSA S136] or Appendix 1 of AISI S100 [CSA S136] is permitted to utilize the restraint provided by *structural sheathing* attached to the compression *flange* of *floor joists* or *ceiling joists* through determination of the rotational stiffness provided to the bending member, k_ϕ of Eq. 1-1. It is also permitted to assume no rotational restraint exists, i.e., $k_\phi = 0$.
- 1.2** Calculation of the *nominal* distortional buckling strength [resistance] in compression in accordance with Section C4.2 of AISI S100 [CSA S136] or Appendix 1 of AISI S100 [CSA S136] is permitted to utilize the restraint provided by *structural sheathing* attached to both *flanges* of *floor joists* or *ceiling joists* through determination of the rotational stiffness provided to the bending member, k_ϕ of Eq. 1-1. It is also permitted to assume no rotational restraint exists, i.e., $k_\phi = 0$.
- 1.3** The rotational stiffness, k_ϕ , shall be determined in accordance with the following:

$$k_\phi = (1/k_{\phi w} + 1/k_{\phi c})^{-1} \quad (\text{Eq. 1-1})$$

where

$k_{\phi w}$ = Sheathing rotational restraint

= $EI_w/L_1 + EI_w/L_2$ for interior members (joists or rafters) with *structural sheathing* fastened on both sides (Eq. 1-2)

= EI_w/L_1 for exterior members (joists or rafters) with *structural sheathing* fastened on one side (Eq. 1-3)

where

EI_w = Sheathing bending rigidity

= Values as specified in Table 1-1(a) for plywood and OSB

= Values as specified in Table 1-1(b) for gypsum board permitted only for serviceability calculations in accordance with Section 1.1.3 of Appendix 1 of AISI S100

L_1, L_2 = One-half joist spacing to the first and second sides respectively, as illustrated in Figure 1-1

$k_{\phi c}$ = *Connection* rotational restraint

= Values as specified in Table 1-2 for fasteners spaced 12 in. o.c. (305 mm) or closer

Table 1-1 (a)^{1,2}
Plywood and OSB Sheathing Bending Rigidity, EI_w (lbf-in²/ft)

Span Rating	Strength Parallel to Strength Axis				Stress Perpendicular to Strength Axis			
	Plywood			OSB	Plywood			OSB
	3-ply	4-ply	5-ply		3-ply	4-ply	5-ply	
24/0	66,000	66,000	66,000	60,000	3,600	7,900	11,000	11,000
24/16	86,000	86,000	86,000	86,000	5,200	11,500	16,000	16,000
32/16	125,000	125,000	125,000	125,000	8,100	18,000	25,000	25,000
40/20	250,000	250,000	250,000	250,000	18,000	39,500	56,000	56,000
48/24	440,000	440,000	440,000	440,000	29,500	65,000	91,500	91,500
16oc	165,000	165,000	165,000	165,000	11,000	24,000	34,000	34,000
20oc	230,000	230,000	230,000	230,000	13,000	28,500	40,500	40,500
24oc	330,000	330,000	330,000	330,000	26,000	57,000	80,500	80,500
32oc	715,000	715,000	715,000	715,000	75,000	615,000	235,000	235,000
48oc	1,265,000	1,265,000	1,265,000	1,265,000	160,000	350,000	495,000	495,000

Note:

- To convert to lbf-in²/in., divide table values by 12.
 To convert to N-mm²/m, multiply the table values by 9.415.
 To convert to N-mm²/mm, multiply the table values by 9.415.
- Plywood and OSB bending rigidity are obtained from APA.

Table 1-1 (b)¹
Gypsum Board Bending Rigidity
Effective Stiffness (Typical Range), EI_w

Board Thickness (in.) (mm)	EI (Lb-in ² /in) of width (N-mm ² /mm)
0.5 (12.7)	1500 to 4000 (220,000 to 580,000)
0.625 (15.9)	3000 to 8000 (440,000 to 1,160,000)

Note:

1. Gypsum board bending rigidity is obtained from the Gypsum Association.

Table 1-2¹
Connection Rotational Restraint

T (mils)	t (in.)	$k_{\phi c}$ (lbf-in./in./rad)	$k_{\phi c}$ (N-mm/mm/rad)
18	0.018	78	348
27	0.027	83	367
30	0.03	84	375
33	0.033	86	384
43	0.043	94	419
54	0.054	105	468
68	0.068	123	546
97	0.097	172	766

Note:

1. Fasteners spaced 12 in. (25.4 mm) o.c. or less.

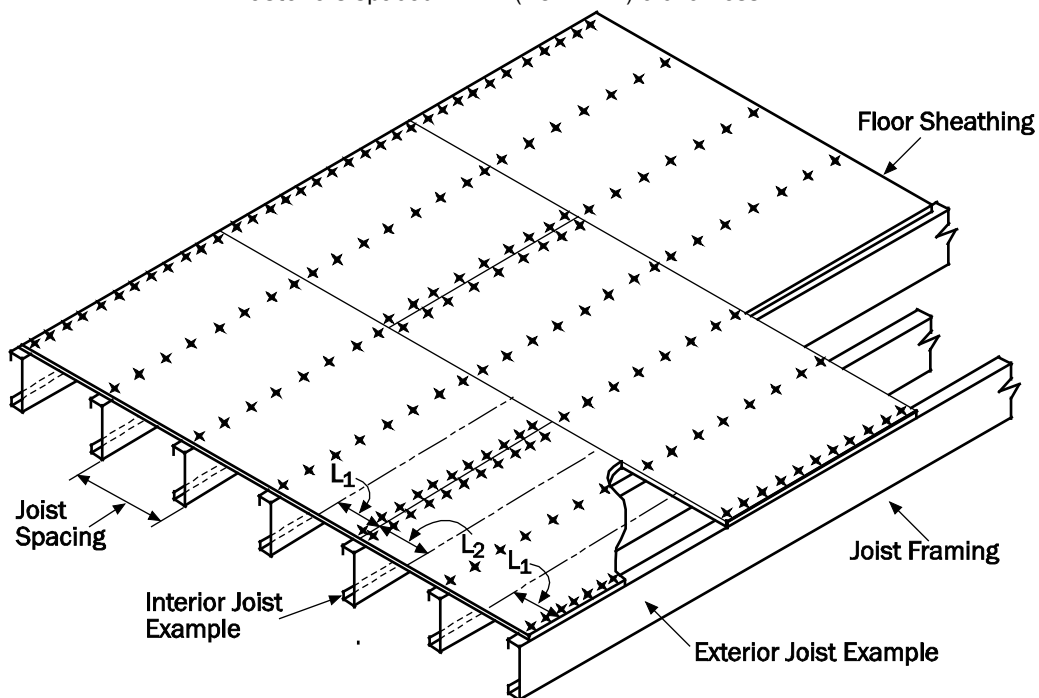

Figure 1-1 Illustration of L_1 and L_2 for Sheathing Rotational Restraint

APPENDIX 2, TEST METHODS FOR TRUSS COMPONENTS AND ASSEMBLIES

2.1 Component Structural Performance Load Test

2.1.1 Flexural Test

Flexural tests shall be performed to determine the positive or negative flexural strength [resistance] of the cross-section of a *truss* member for *static load*.

2.1.1.1 Number of Test Specimens

The minimum number of test specimens shall be in accordance with Section F1 of AISI S100 [CSA S136].

2.1.1.2 Materials

The test specimens shall be representative of those intended for use in the final product. Mechanical properties of the steel shall be determined in accordance with Section F3 of AISI S100 [CSA S136].

2.1.1.3 Test Apparatus

The test apparatus and procedures employed shall produce a failure consistent with the purpose.

2.1.1.4 Load and Deflection Measuring Devices

The *load* measuring device or devices used shall be capable of measuring *loads* to an accuracy of $\pm 2\%$ of the ultimate load.

The deflection measuring devices, if employed, shall avoid magnification of deflection readings due to a movement of supports during loading. When deflection measuring systems that do not compensate for support settlement are used, measurement of support displacement under *load* shall be required in order to obtain an accurate *load*-deflection response. Deflection readings and measuring devices shall have an accuracy of 0.01 inches (0.25 mm).

2.1.1.5 Loading Procedures

Load shall be applied and *load* measurements shall be taken. The maximum loading rate shall not exceed a corresponding applied stress rate of 3 ksi (20.7 MPa) of gross cross-sectional area per minute.

2.1.1.6 Interpretation of Test Results

Evaluation of the test results shall be made in accordance with Section F1 of AISI S100 [CSA S136].

2.1.1.7 Report

The test report shall include a description of the test specimen with drawings detailing all pertinent dimensions. The description shall define the size, geometric type, and strength of all test specimen components. Pertinent connector information shall include type and size.

The measured mechanical properties (base steel thickness, yield stress, tensile strength

and percent elongation) of the tested specimens shall be included.

The documentation shall include details of the test setup, load application, deflection measurement locations, and drawings illustrating the test fixture.

The test report shall include the ultimate load, description of the failure mode(s), and load-deflection curves (or the load-deflection measurements).

The report shall include certification that the test program was performed under the direction of a *registered design professional*.

2.1.2 Compression Test

Compression tests shall be performed to define the compressive strength [resistance], excluding overall buckling, of a *truss* member for *static load* in accordance with AISI S902. Alternative tests methods shall be permitted, when accepted by the *truss designer*.

2.2 Full-Scale Confirmatory Load Test

2.2.1 Test Specimen

For the purpose of this test, a test specimen shall consist of a full-scale *truss* assembly representative of those intended for use in the final product.

2.2.2 Number of Test Specimens

A single confirmatory load test shall meet the required minimum number of test specimens.

2.2.3 Materials

The materials contained within the test specimen shall be representative of those intended for use in the final product. Mechanical properties of the steel shall be determined in accordance with Section F3 of AISI S100 [CSA S136].

2.2.4 Fabrication

Fabrication of the test specimen shall be representative of that intended for the finished product.

2.2.5 Test Apparatus

A test shall consist of a single *truss*, pair of *trusses*, or multiple *trusses*.

A single *truss* shall be tested in either a vertical position (normal or inverted) or in a horizontal position. A pair of *trusses* or multiple *trusses* shall be tested in a vertical position (normal or inverted).

The self-weight of the *truss* shall be included in the total *load* applied to *trusses* that are tested in a vertical position to compensate for the effect of dead *loads* and gravity.

Reaction supports shall provide clearance above the ground or restraining frame to allow for normal displacements, ease of loading, instrumentation, and provide room for observations and measurements. Supports shall have strength and stiffness to resist deformations during tests.

Support reaction hardware shall be typical of that planned for use in the completed structure or as required to satisfy the intent of the tests.

Lateral support shall be provided beneath a single *truss* when tested horizontally to keep

the test *truss* flat and to minimize any adverse lateral displacement caused by gravity. Lateral support shall be provided for single, paired, or multiple *trusses* when tested vertically to minimize adverse lateral displacement and prevent buckling of the assembly. Where lateral support is used, it shall not interfere with the free in-plane displacement of the *truss* or *truss* assembly. The components of the test *truss* shall not be laterally supported in a manner that will exceed that intended in a representative installation.

When *loads* are applied using dead weight, such as sand, masonry units, or water, the dead *load* material shall be positioned to prevent arching action.

When *loads* are applied using water, the water shall be compartmentalized into cells to prevent a non-uniform *load* as the *truss* deflects.

2.2.6 Load and Deflection Measuring Devices

The load measuring device or devices used shall be capable of measuring loads to an accuracy of $\pm 2\%$ of the ultimate load. When multiple *trusses* are tested as an assembly, *load*-measuring devices shall be located beneath each *truss* support.

The deflection measuring devices, if employed, shall avoid magnification of deflection readings due to a movement of supports during loading. When deflection-measuring systems that do not compensate for support settlement are used, measurement of support displacement under *load* shall be required in order to obtain an accurate *load*-deflection response. Deflection readings and measuring devices shall have an accuracy of 0.01 inches (0.25 mm).

2.2.7 Loading Procedures

Loading of the test specimens shall be achieved either using an incremental loading or a continuous loading method.

2.2.7.1 Tests to Confirm Deflection

When a test to confirm deflection is required, the test load shall be applied up to the maximum load for deflection limit, at which time deflections shall be measured. When loading incrementally, each of the increments of test *load* shall not exceed 1/5 of the maximum load. When using continuous loading, the applied load shall be increased uniformly until the maximum load is reached.

When testing *trusses* in pairs, the deflections of two *trusses* at corresponding locations are permitted to be averaged. Support displacement under load shall be measured to obtain an accurate load-deflection response when deflection-measuring systems that do not compensate for support settlement are used.

2.2.7.2 Tests to Confirm Available Strength [Factored Resistance] Assumptions

When a test to confirm *available strength* [*factored resistance*] is required, the test load shall be applied up to the *design load* times 1.65 for ASD and the *design* [*factored*] *load* for LRFD [LSD]. When loading incrementally, each of the increments of test load shall not exceed 1/5 of the *design load* times 1.65 for ASD and the *design* [*factored*] *load* for LRFD [LSD]. When using continuous loading, the applied load shall be increased uniformly until the *design load* times 1.65 ASD or the *design* [*factored*] *load* for LRFD [LSD] is reached. This load shall be held for not less than 5 minutes, and then the confirmatory test shall be considered complete.

2.2.8 Interpretation of Test Results

The confirmatory test shall be deemed successful if the test specimen complies with the loading requirements in Section 2.2.7. When a test to confirm design deflections is required, the test shall be deemed successful if the measured deflections of the test specimen do not exceed the design (dead plus live *load*) deflection limit.

2.2.9 Report

The test report shall include a description of the test specimen configuration with drawings detailing all pertinent dimensions. The description shall define the size, geometric type, and strength of all test specimen components. Pertinent connector information shall include type and size.

The measured mechanical properties (including base steel thickness, yield stress, tensile strength and percent elongation) of the tested specimens shall be included.

The documentation shall include details of the test setup, load application, deflection measurement locations, and drawings illustrating the test fixture.

The test report shall include the ultimate load, description of the failure mode(s), and load-deflection curves (or the load-deflection measurements).

The report shall include certification that the test program was performed under the direction of a *registered design professional*.

2.3 Full-Scale Structural Performance Load Test

2.3.1 Test Specimen

For the purpose of this test, a test specimen shall consist of a full-scale *truss* assembly representative of those intended for use in the final product.

2.3.2 Number of Test Specimens

The minimum number of test specimens shall be in accordance with Section F1 of AISI S100 [CSA S136].

2.3.3 Materials

The materials contained within the test specimen shall be representative of those intended for use in the final product. Mechanical properties of the steel shall be determined in accordance with Section F3 of AISI S100 [CSA S136].

2.3.4 Fabrication

Fabrication of the test specimen shall be representative of that intended for the finished product.

2.3.5 Test Apparatus

A test shall consist of a single *truss*, pair of *trusses* or multiple *trusses*.

A single *truss* shall be tested in either a vertical position (normal or inverted) or in a horizontal position. A pair of *trusses* or multiple *trusses* shall be tested in a vertical position (normal or inverted).

The self-weight of the *truss* shall be included in the total *load* applied to *trusses* that are tested in a vertical position to compensate for the effect of dead *loads* and gravity.

Reaction supports shall provide clearance above the ground or restraining frame to allow for displacements, loading, instrumentation, and provide room for observations and measurements. Supports shall have strength and stiffness to resist deformations during tests.

Support reaction hardware shall be typical of that planned for use in the completed structure or as required to satisfy the intent of the tests.

Lateral support shall be provided beneath a single *truss* when tested horizontally to keep the test *truss* flat and to minimize any adverse lateral displacement caused by gravity. Lateral support shall be provided for single, paired or multiple *trusses* when tested vertically to minimize adverse lateral displacement and prevent buckling of the assembly. Where lateral support is used, it shall not interfere with the free in-plane displacement of the *truss* or *truss* assembly. The components of the test *truss* shall not be laterally supported in a manner that will exceed that intended in a representative installation.

When *loads* are applied using dead weight, such as sand, masonry units, or water, the dead *load* material shall be positioned to prevent arching action.

When *loads* are applied using water, the water shall be compartmentalized into cells to prevent a non-uniform *load* as the *truss* deflects.

2.3.6 Load and Deflection Measuring Devices

When multiple *trusses* are tested as an assembly, *load*-measuring devices shall be located beneath each *truss* support. The *load* measuring device or devices used shall be capable of measuring *loads* to an accuracy of $\pm 2\%$ of the ultimate load.

The deflection measuring devices, if employed, shall avoid magnification of deflection readings due to a movement of supports during loading. When deflection-measuring systems that do not compensate for support settlement are used, measurement of support displacement under *load* shall be required in order to obtain an accurate *load*-deflection response. Deflection readings and measuring devices shall have an accuracy of 0.01 inches (0.25 mm).

2.3.7 Loading Procedures

Loading of the test specimens shall be achieved using either an incremental or a continuous loading method.

When loading incrementally, each of the increments of test load shall not exceed 1/5 of the estimated ultimate load. If structural failure has not occurred at the estimated ultimate load, additional load is to be applied in the same increments until failure occurs.

When using continuous loading, the applied load shall be increased uniformly until structural failure occurs.

Deflection readings shall be recorded at each load increment or continuously. When testing *trusses* in pairs, the deflections of two *trusses* at corresponding locations are permitted to be averaged. Support displacement under load shall be measured to obtain an accurate *load*-deflection response when deflection-measuring systems that do not compensate for support settlement are used.

For incremental loading, the ultimate load shall be the load level before failure. For continuous loading, the ultimate load shall be the load at failure.

2.3.8 Interpretation of Test Results

The performance test is permitted to be used to determine the *available strength* [*factored*

resistance] for the truss. For ASD, the *available strength* of the truss shall be the *nominal strength* divided by the *safety factor*; and for LRFD [LSD], the *available strength* [*factored resistance*] of the truss shall be the *nominal strength* [*resistance*] multiplied by the *resistance factor*. The *nominal strength* [*resistance*] of the truss is permitted to be taken as the average of the ultimate loads of the tested specimens. The *resistance factor* or *safety factor* for the performance test shall be determined in accordance with Section F1 of AISI S100 [CSA S136].

2.3.9 Report

The test report shall include a description of the test specimen configuration with drawings detailing all pertinent dimensions. The description shall define the size, geometric type, and strength of all test specimen components. Pertinent connector information shall include type and size.

The measured mechanical properties (including base steel thickness, yield stress, tensile strength and percent elongation) of the tested specimens shall be included.

The documentation shall include details of the test setup, load application, deflection measurement locations, and drawings illustrating the test fixture.

The test report shall include the ultimate load, description of the failure mode(s), and load-deflection curves (or the load-deflection measurements).

The report shall include certification that the test program was performed under the direction of a *registered design professional*.



AISI STANDARD

Commentary on the North American Standard for Cold-Formed Steel Structural Framing

2015 Edition

DISCLAIMER

The material contained herein has been developed by the American Iron and Steel Institute (AISI) Committee on Framing Standards. The Committee has made a diligent effort to present accurate, reliable, and useful information on cold-formed steel framing design and installation. The Committee acknowledges and is grateful for the contributions of the numerous researchers, engineers, and others who have contributed to the body of knowledge on the subject. Specific references are included in this *Commentary*.

With anticipated improvements in understanding of the behavior of cold-formed steel framing and the continuing development of new technology, this material will become dated. It is anticipated that AISI will publish updates of this material as new information becomes available, but this cannot be guaranteed.

The materials set forth herein are for general purposes only. They are not a substitute for competent professional advice. Application of this information to a specific project should be reviewed by a *design professional*. Indeed, in many jurisdictions, such review is required by law. Anyone making use of the information set forth herein does so at their own risk and assumes any and all liability arising therefrom.

1st Printing – December 2015

Copyright American Iron and Steel Institute 2015

PREFACE

This *Commentary* is intended to facilitate the use and provide an understanding of the background of AISI S240, *North American Standard for Cold-Formed Steel Structural Framing*. The *Commentary* illustrates the substance and limitations of the various provisions of the Standard.

In the *Commentary*, sections are identified by the same notation as used in the Standard. Words that are italicized are defined in AISI S240. Terms included in square brackets are specific to *Limit States Design* terminology.

This Page is Intentionally Left Blank.

TABLE OF CONTENTS
COMMENTARY ON THE NORTH AMERICAN STANDARD
FOR COLD-FORMED STEEL STRUCTURAL FRAMING

Disclaimer	ii
Preface.....	iii
COMMENTARY ON THE NORTH AMERICAN STANDARD FOR COLD-FORMED STEEL STRUCTURAL FRAMING	1
A. GENERAL	1
A1 Scope.....	1
A2 Definitions	2
A2.1 Terms.....	2
A3 Material.....	4
A4 Corrosion Protection	4
A5 Products	5
A5.2 Minimum Flange Width.....	6
B DESIGN	7
B1 General.....	7
B1.1 Loads and Load Combinations.....	7
B1.1.1 Live Load Reduction on Wall Studs.....	7
B1.1.2 Wind Loading Considerations in the United States and Mexico.....	7
B1.2 Design Basis.....	8
B1.2.1 Floor Joists, Ceiling Joists and Roof Rafters	8
B1.2.2 Wall Studs	8
B1.2.3 In-Line Framing.....	9
B1.2.5.2 Principles of Mechanics	10
B1.3 Built-Up Sections	10
B1.5 Connection Design	11
B1.5.1 Screw Connections.....	11
B1.5.1.1 Steel-to-Steel Screws.....	11
B1.5.1.3 Spacing and Edge Distance.....	12
B1.5.1.4 Gypsum Board	12
B1.5.2 Welded Connections.....	13
B1.5.3 Bolts.....	13
B1.5.4 Power-Actuated Fasteners.....	13
B1.5.5 Other Connectors.....	13
B2 Floor and Ceiling Framing	13
B2.5 Bearing Stiffeners.....	13
B2.6 Bracing Design.....	13
B3 Wall Framing.....	13
B3.2 Wall Stud Design.....	13
B3.2.1 Axial Load.....	13
B3.2.5 Web Crippling	16
B3.2.5.1 Stud-to-Track Connection for C-Section Studs	16
B3.2.5.2 Deflection Track Connection for C-Section Studs.....	18
B3.3 Header Design	19
B3.3.1 Back-to-Back Headers.....	19
B3.3.2 Box Headers.....	19
B3.3.3 Double L-Headers.....	20

B3.3.3.1.1 Gravity Loading.....	21
B3.3.3.1.2 Uplift Loading.....	21
B3.3.4 Single L-Headers.....	21
B3.3.5 Inverted L-Header Assemblies.....	22
B3.4 Bracing.....	23
B3.4.1 Intermediate Brace Design.....	23
B3.5 Serviceability.....	23
B4 Roofing Framing.....	23
B4.5 Bracing Design.....	23
B5 Lateral Force-Resisting Systems.....	23
B5.2 Shear Wall Design.....	23
B5.2.1 General.....	24
B5.2.2 Nominal Strength [Resistance].....	25
B5.2.2.1 Type I Shear Walls.....	25
B5.2.2.2 Type II Shear Walls.....	28
B5.2.3 Available Strength [Factored Resistance].....	29
B5.2.5 Design Deflection.....	29
B5.3 Strap Braced Wall Design.....	30
B5.4 Diaphragm Design.....	31
B5.4.1 General.....	31
B5.4.2 Nominal Strength.....	31
B5.4.4 Design Deflection.....	32
B5.4.5 Beam Diaphragm Tests for Non-Steel Sheathed Assemblies.....	32
C. INSTALLATION.....	34
C2 Material Condition.....	34
C2.1 Web Holes.....	34
C2.2 Cutting and Patching.....	34
C2.3 Splicing.....	34
C3 Structural Framing.....	34
C3.1 Foundation.....	34
C3.2 Ground Contact.....	34
C3.3 Floors.....	35
C3.4 Walls.....	35
C3.4.1 Straightness, Plumbness and Levelness.....	35
C3.4.3 Stud-to-Track Connection.....	35
C3.5 Roofs and Ceilings.....	36
C3.6 Lateral Force-Resisting Systems.....	36
C4 Connections.....	37
C4.1 Screw Connections.....	37
C4.1.2 Installation.....	37
C4.1.3 Stripped Screws.....	37
C4.2 Welded Connections.....	37
C5 Miscellaneous.....	37
C5.1 Utilities.....	37
C5.1.1 Holes.....	37
C5.1.2 Plumbing.....	38
C5.1.3 Electrical.....	38
C5.2 Insulation.....	38

D. QUALITY CONTROL AND QUALITY ASSURANCE.....	39
D1 General.....	39
D1.1 Scope and Limits of Applicability.....	39
D1.2 Responsibilities.....	40
D2 Quality Control Programs.....	40
D3 Quality Control Documents.....	41
D3.1 Documents to be Submitted.....	41
D3.2 Available Documents.....	41
D5 Inspection Personnel.....	42
D5.1 Quality Control Inspector.....	42
D5.2 Quality Assurance Inspector.....	42
D6 Inspection Tasks.....	42
D6.1 General.....	42
D6.2 Quality Control Inspection Tasks.....	42
D6.3 Quality Assurance Inspection Tasks.....	43
D6.4 Coordinated Inspection.....	43
D6.5 Material Verification.....	43
D6.6 Inspection of Welding.....	43
D6.7 Inspection of Mechanical Fastening.....	43
D6.8 Inspection of Cold-Formed Steel Light-Frame Construction.....	43
D6.9 Additional Requirements for Lateral Force-Resisting Systems.....	43
E. TRUSSES.....	45
E1 General.....	45
E1.1 Scope and Limits of Applicability.....	45
E2 Truss Responsibilities.....	45
E3 Loading.....	45
E4 Truss Design.....	45
E4.3 Analysis.....	45
E4.4 Member Design.....	45
E4.4.1 Properties of Sections.....	45
E4.4.2 Compression Chord Members.....	46
E4.4.3 Tension Chord Members.....	47
E4.4.4 Compression Web Members.....	47
E4.4.5 Tension Web Members.....	48
E4.4.6 Eccentricity in Joints.....	48
E4.5 Gusset Plate Design.....	49
E4.6 Connection Design.....	51
E4.6.1 Fastening Methods.....	51
E4.6.2 Coped Connections for C-Shaped Sections.....	52
E4.7 Serviceability.....	53
E5 Quality Criteria for Steel Trusses.....	53
E6 Truss Installation.....	54
E6.1.1 Straightness.....	54
E6.1.2 Plumbness.....	54
E7 Test-Based Design.....	54
F. TESTING.....	55
F1 General.....	55
F2 Truss Components and Assemblies.....	55

APPENDIX 1, CONTINUOUSLY BRACED DESIGN FOR DISTORTIONAL BUCKLING RESISTANCE.....	56
APPENDIX 2, TEST METHODS FOR TRUSS COMPONENTS AND ASSEMBLIES	57
2.1 Component Structural Performance Load Test.....	57
2.2 Full-Scale Confirmatory Load Test	57
2.3 Full-Scale Structural Performance Load Test	58
REFERENCES.....	59

COMMENTARY ON THE NORTH AMERICAN STANDARD FOR COLD-FORMED STEEL STRUCTURAL FRAMING

A. GENERAL

In 2015, the following AISI cold-formed steel framing standards were consolidated into a single standard, AISI S240 (AISI, 2015a):

- AISI S200, *North American Standard for Cold-Formed Steel Framing – General Provisions* (AISI, 2012b)
- AISI S210, *North American Standard for Cold-Formed Steel Framing – Floor and Roof System Design* (AISI, 2012d)
- AISI S211, *North American Standard for Cold-Formed Steel Framing – Wall Stud Design* (AISI, 2012e)
- AISI S212, *North American Standard for Cold-Formed Steel Framing – Header Design* (AISI, 2012f)
- AISI S213, *North American Standard for Cold-Formed Steel Framing – Lateral Design* (AISI, 2012g)
- AISI S214, *North American Standard for Cold-Formed Steel Framing – Truss Design* (AISI, 2012i)

In 2015, AISI S400, *North American Standard for Seismic Design of Cold-Formed Steel Structural Systems* (AISI, 2015b) was developed. Modifications were made to align the provisions of AISI S240 with AISI S400, as follows:

- The applicability of AISI S240 for seismic design was limited to applications where specific seismic detailing is not required.
- Definitions no longer needed in AISI S240 were removed and remaining definitions were revised, if needed, for consistency with AISI S400.
- Seismic-specific tables for *nominal shear strength [resistance]* were deleted.
- Seismic-specific *safety factors* and *resistance factors* were deleted.
- Other seismic-specific requirements were removed, as appropriate, and remaining requirements were generalized for applicability to wind, seismic or other lateral loads.

A1 Scope

AISI S240 applies to the design and installation of *structural members* utilized in *cold-formed steel light-frame construction* applications and other structures. It applies to floor, wall and roof systems, *lateral force-resisting systems* and *trusses*. However, *cold-formed steel structural members* and *connections* in *seismic force-resisting systems* must be designed in accordance with the additional provisions of AISI S400 where increased seismic performance is required.

The Standard is intended to serve as a supplement to AISI S100 [CSA S136] (AISI, 2012a; CSA, 2012).

Design provisions related to *nonstructural members* can be found in AISI S220, *North American Standard for Cold-Formed Steel Framing-Nonstructural Members* (AISI, 2011b). However, the use of AISI S240 for the design of *nonstructural members* is permitted, since the requirements specified in AISI S240 for *structural members* are equivalent or more stringent than the requirements specified in AISI S220 for *nonstructural members*.

In 2015, the provision that the Standard applies to applications where the specified minimum *base steel thickness* is not greater than 0.1180 inches (2.997 mm) was replaced with the

provision that the Standard applies to *light-frame construction* applications, and a definition for the term *light-frame construction* was added to the Standard. *Cold-formed steel structural members* for *light-frame construction* applications are available in a variety of thicknesses. Standard thicknesses for *cold-formed steel structural members* are defined in AISI S201 (AISI, 2012c).

A2 Definitions

A2.1 Terms

Codes and standards by their nature are technical, and as such specific words and phrases can change the intent of the provisions if not properly defined. As a result, it is necessary to establish a common platform by clearly stating the meaning of specific terms for the purpose of this Standard and other standards that reference it.

In the Standard, *blocking* is defined to transfer shear force or stabilize members. Figures C-A2-1 and C-A2-2 show examples of how *track* or *stud* members are used as *blocking* in various assemblies.

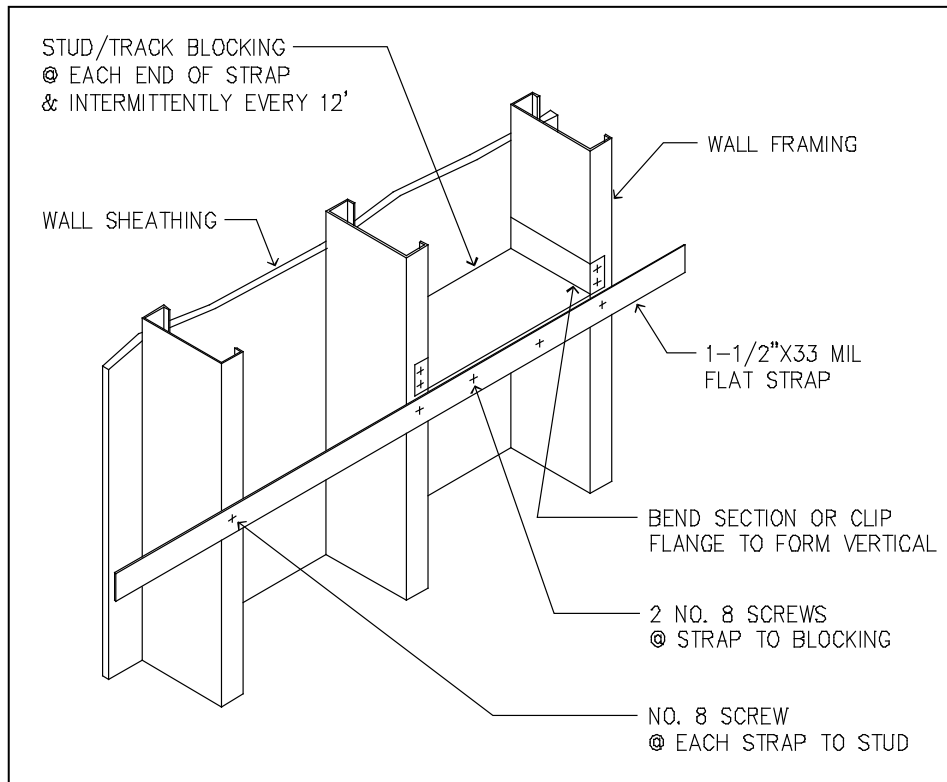

Figure C-A2-1 Application of Stud Track Blocking

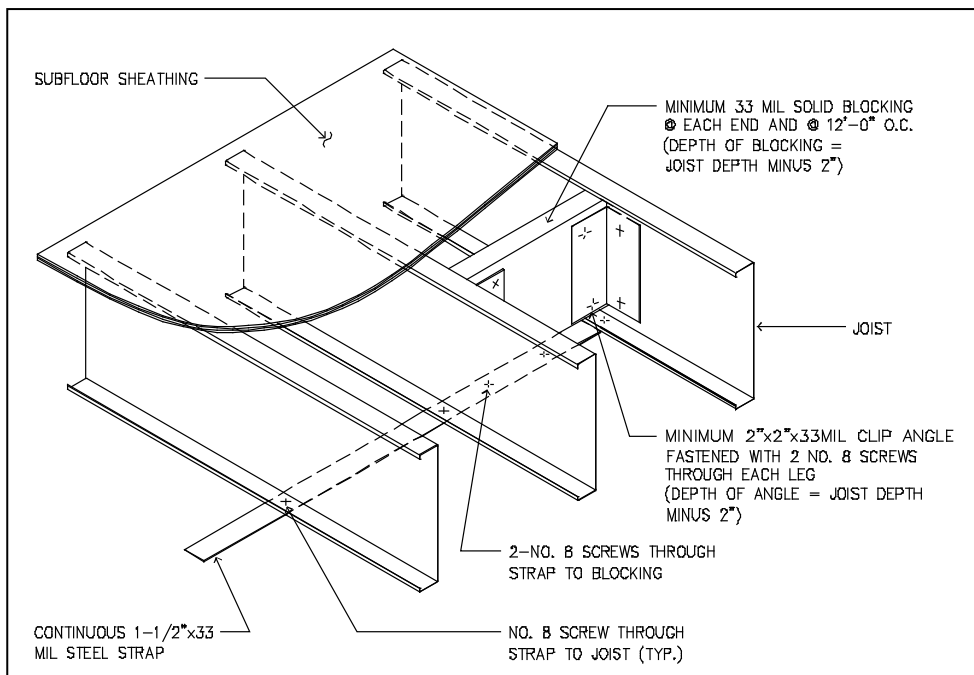

Figure C-A2-2 Application of Joist Blocking

A3 Material

The sheet steel approved for use with this Standard for *structural members* must comply with ASTM A1003/A1003M (ASTM, 2015), except where specifically noted otherwise. ASTM A1003/1003M covers the chemical, mechanical and coating requirements for steel sheet used in the manufacture of *cold-formed steel* framing members such as *studs*, *joists*, and *tracks*.

ASTM A1003/1003M is a standard that was developed in order to incorporate requirements for metallic-coated, painted metallic-coated, or painted nonmetallic-coated steel sheet used for *cold-formed steel* framing members into a single standard. Mechanical properties defined in ASTM A1003/A1003M are minimum requirements. For example, the minimum *yield strength* of Type H or L 33 [NS230] steel is 33 ksi [230 MPa]; material with higher *yield strength* is permitted, but 33 ksi [230 MPa] is the design *yield strength*. Additionally, according to the ASTM A1003/1003M standard, Structural Grade Types H and L steel are intended for *structural members* and nonstructural Grade Type NS steel is intended for *nonstructural members*. It is noted that additional country-specific limitations for *curtain wall studs* are provided in AISI S100 [CSA S136], Section A2.3.1a, Appendix A or B.

A4 Corrosion Protection

The minimum coating designations listed in Standard Table A4-1 assume normal exposure and construction practices. Other types of coatings that provide equal or better corrosion protection may also be acceptable. When more severe exposure conditions are probable, consideration should be given to specifying heavier coating weight [mass].

The minimum coating specified by this Standard assumes normal exposure conditions that are defined as having the framing members enclosed within a building envelope or wall assembly within a controlled environment. When more severe exposure conditions are probable, such as industrial atmospheres and marine atmospheres, consideration should be given to specifying a heavier coating. Coating is specified by weight or mass.

This Standard does not require the edges of metallic-coated *cold-formed steel* framing members (shop or field cut in accordance with Standard Section C2.2, punched or drilled) to be touched up with zinc-rich paint, which is able to galvanically protect steel. When base steel is exposed, such as at a cut or scratch, the steel is cathodically protected by the sacrificial corrosion of the zinc coating, because zinc is more electronegative (more reactive) than steel in the galvanic series. A zinc coating will not be undercut because the steel cannot corrode when adjacent to the zinc coating. Therefore, any exposure of the underlying steel at an edge or scratch will not result in corrosion of the steel away from the edge or scratch and thus will not affect the performance of the coating or the steel structure (CFSEI, 2007a).

It is noted that ASTM A1004/A1004M (ASTM, 2014b) covers procedures for establishing the acceptability of steel sheet for use as *cold-formed steel* framing members. This practice is to be used to assess the corrosion resistance of different coatings on steel sheet in a laboratory test. It is not intended to be used as an application performance standard for the *cold-formed steel* framing, but is to be used to evaluate coatings under consideration for addition to ASTM A1003/A1003M (ASTM, 2015).

Direct contact with dissimilar metals (e.g., copper, brass, etc.) should be avoided in order to prevent unwanted galvanic action from occurring. Methods for preventing the contact from occurring may be through the use of nonconductive and noncorrosive grommets at *web* penetrations or through the use of non-metallic brackets (a.k.a. isolators) fastened to hold the dissimilar metal building products (e.g. piping) away from the *cold-formed steel* framing. In 2006, a change was made to this Standard allowing the use of dissimilar metals in contact with *cold-*

formed steel framing, provided the specific application is approved. It was recognized that dissimilar metals in contact with *cold-formed steel* framing might not always be a problem. For example, there are no galvanic concerns where there is no moisture. A special case of dissimilar metals occurs in Canada where, for certain climatic conditions and building heights, the use of stainless steel brick ties is required. When these ties are connected to steel *stud* backup, contact between dissimilar metals can occur. For guidance on this dissimilar metals issue, refer to the Canadian standard CAN/CSA-A370-14, *Connectors for Masonry* (CSA, 2014).

When there is direct contact of *cold-formed steel* framing with pressure-treated wood, the treated wood, *cold-formed steel* framing, connector and/or fastener manufacturers should be contacted for recommendations. Methods that should be considered may include specifying a less corrosive pressure treatment (sodium borate, organic preservative systems, etc.), isolating the *cold-formed steel* and wood components, or changing details to avoid use of pressure-treated wood altogether.

Design professionals should take into account both the initial contact with wet or damp building materials, as well as the potential for those materials to absorb water during the building's life, as both circumstances may accelerate corrosion.

In 2007, the Cold-Formed Steel Engineers Institute updated the 2004 AISI document, entitled *Durability of Cold-Formed Steel Framing Members* (CFSEI, 2007a), to give engineers, architects, builders and homeowners a better understanding of how galvanizing (zinc and zinc alloy coatings) provides long-term corrosion protection to *cold-formed steel* framing members. Additional information can be obtained from the American Galvanizers Association publication entitled *Hot Dip Galvanizing For Corrosion Protection – A Specifier's Guide* (AGA, 2012) and the Cold-Formed Steel Engineers Institute's publication entitled *Corrosion Protection for Cold-Formed Steel Framing in Coastal Areas* (CFSEI, 2007b).

A5 Products

AISI S100 [CSA S136], (AISI, 2012a; CSA, 2012) permits the minimum delivered *base steel thickness* (exclusive of any coatings) of a *cold-formed steel* member to be 95% of the *design thickness*. This Standard, therefore, specifies the minimum *base steel thickness* that complies with AISI S100 [CSA S136]. The thickness designations are consistent with standard industry practice, as published in AISI S201 (AISI, 2012c). It is recommended that thickness measurements be taken in the middle of the flat of the *flange* or *web* of the cross-section.

Section A5.3 has adopted a standard designator system for identifying *cold-formed steel* framing members. The intent for using a standard designator system was to overcome the varied designators that were produced by each individual manufacturer. In addition, the designator is used to identify not only a specific *cold-formed steel* framing member, but also to identify the section properties of that same member through the use of the manufacturer's product technical information documents.

The following presents an example of the standard designator for a *cold-formed steel stud*:

350S162-33 represents a member with the following:

350S162-33

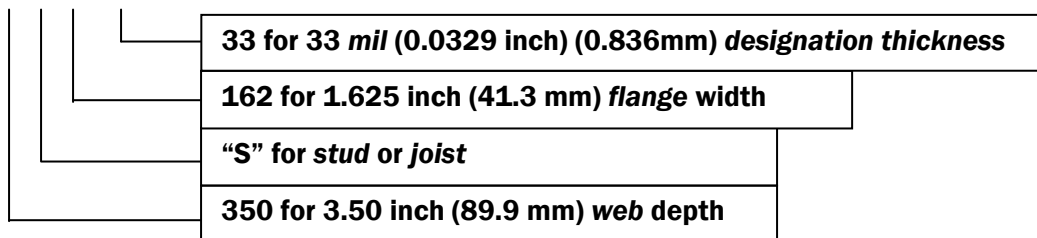

In 2011, as part of an exercise to synchronize all relevant codes and specifications, the minimum tolerances for the manufacture of *cold-formed steel* framing members were included in the AISI framing standards. The minimum tolerances for the manufacture of *structural members* can be found in Section A5.4. In 2014, manufacturing tolerances for stiffening lip length and *flange* width were also added. The revisions are consistent with ASTM C955 (ASTM, 2011c). The minimum tolerances for the manufacture of *nonstructural members* can be found in AISI S220 (AISI, 2015). The manufacturing tolerances for length, *web* width, camber, bow, twist, etc. of framing members are consistent with ASTM C955, ASTM C645 (ASTM, 2011b), and manufacturers' certification programs.

To aid in shop and field verification, all framing members are to carry a product identification to indicate conformance with the minimum *base steel thickness*, coating designation, minimum *yield strength*, and manufacturer's name.

In 2011, color coding of individual framing members or groups of like members were removed from the AISI framing standards with consideration that the color coding approach could cause confusion in differentiating between *structural* and *nonstructural members* of the same thickness. Further, color coding is optional and the criterion, if needed, exists in a non-mandatory Appendix of ASTM C645.

A5.2 Minimum Flange Width

In 2012, as part of an exercise to synchronize all relevant codes and specifications, the provisions for minimum *flange* width were added to the AISI framing standards, and were consistent with ASTM C645 (ASTM, 2011b) and ASTM C955 (ASTM, 2011c). The minimum *flange* width for *C-shape* members was included in the Standard to accommodate a butt joint of sheathing. The minimum *flange* width for *track* members was included in the Standard to accommodate an edge joint of sheathing.

B DESIGN

B1 General

B1.1 Loads and Load Combinations

Currently, ASCE 7 (ASCE, 2013) has no geographical-based information on Mexico. Therefore, users with projects in Mexico should work with the appropriate *authority having jurisdiction* to determine appropriate loads and load combinations that are consistent with the assumptions and rationale used by ASCE 7.

In 2009, the words “with no axial loads” were deleted to clarify that the intent is to evaluate deflections for bending of the wall *stud* alone when subjected to the Components and Cladding (C&C) wind loads.

B1.1.1 Live Load Reduction on Wall Studs

Since some building codes allow designers to reduce floor live load as a function of area of floor supported by gravity load-bearing members, a requirement was added in 2009 to clarify appropriate application of area live load reduction for the design of individual *structural members* in load-bearing wall framing, including vertical members such as *studs* or columns and horizontal members such as *headers* or beams within a wall assembly. The floor area (from one or more floors) contributing load to a wall framing member should be determined in a manner consistent with engineering mechanics.

B1.1.2 Wind Loading Considerations in the United States and Mexico

Because a wall *stud* subject to combined bending and axial load resists wind loads imposed on two surfaces, the member can be analyzed based on Main Wind Force Resisting System (MWFRS) wind loads. For bending alone, the wall *stud* experiences wind from only one surface and therefore must be analyzed for Components and Cladding (C&C) wind loads.

Section 1609.6.2.3 of the *International Building Code* (ICC, 2003) states that:

“Members that act as both part of the main force resisting system and as components and cladding shall be designed for each separate load case.”

Discussion in the *Southern Standard Building Code Commentary* (SBCCI, 1999) sheds light on a reasonable approach to the design of wall *studs* for wind resistance, stating that:

“Some elements of a building will function as part of the main wind force resisting system and components and cladding also. Such members include but not limited to roof panels, rafters, and wall studs. These elements are required to be designed using the loads that would occur by considering the element as part main wind force resisting system, and also separately checked or designed for loads that would occur by considering the element as component and cladding. The use of this section can be demonstrated by considering, for example, the design of a wall stud. When designing the stud for main wind force resisting system loads, all loads such as bending from the lateral force with the wind on the wall in addition to any uplift in combinations with the dead load of the roof or a story above induced by the simultaneous action of roof forces should be considered together. When designing the stud for component and cladding loads, only the bending resulting from the wind force normal to the stud and the dead load associated with that member should be considered. The member should be sized according to the more critical loading condition.”

The wood industry has also investigated this condition and has adopted a similar policy as shown in the *Wood Frame Construction Manual* (AFPA, 1995), where Section 2.4 states that:

“Studs tables are based upon bending stresses induced by C&C Loads. The bending stresses are computed independent of axial stresses. In addition, the case in which bending stresses from MWFRS loads act in combination with axial stresses from wind and gravity loads have been analyzed. For buildings limited to the conditions in the WFCM-SBC, the C&C loads control stud design.”

The commentary to Appendix C of ASCE 7 (ASCE, 2006) provides some guidance on the selection of loads for checking the serviceability limit state of buildings and their components, where Section B1.2 states in part:

“Use of factored wind load in checking serviceability is excessively conservative. The load combination with an annual probability of 0.05 of being exceeded, which can be used in checking short-term effects, is $D + 0.5L + 0.7W$.”

Thus, using 70% of the wind load from Components and Cladding for checking deflections should conservatively satisfy the above. In 2012, IBC Table 1604.3, Footnote f recommended that 42% of the wind load be used for checking deflections. The 2012 IBC is based on ASCE 7-10 and the ASD wind load factor of $0.6W$ is used to arrive at a service load pressure; thus, $0.7 \times 0.6 = 0.42$.

AISC Design Guide No. 3 (Fisher and West, 1990) also recommends reduced wind loads when checking the serviceability of cladding based upon a 10-year return period or 75 percent of the 50-year wind pressure.

B1.2 Design Basis

The strength determinations required by this Standard are to be in accordance with AISI S100 [CSA S136], (AISI, 2012a; CSA, 2012). For design guidance on the application of AISI S100 [CSA S136] to typical *cold-formed steel* construction, refer to *Design Guide for Cold-Formed Steel Framing* (AISI, 2007b) and *Cold-Formed Steel Design* (Yu and LaBoube, 2010).

B1.2.1 Floor Joists, Ceiling Joists and Roof Rafters

The Standard permits the design of *floor joists*, *ceiling joists* and *roof rafters* to be based on either a discretely braced design in which discrete braces are provided along the member's length, or based on a continuously braced design in which attached sheathing or deck are attached in accordance with the Standard.

The continuously braced design provisions of the Standard are limited to *floor joists*, *ceiling joists* and *roof rafters* with dimensions and properties that are within the range of standard products, as defined by AISI S201 (AISI, 2012c). This limitation was deemed appropriate due to the availability of research and field experience with such members.

B1.2.2 Wall Studs

The 2007 edition of AISI S100 (AISI, 2007a) added new design provisions for considering distortional buckling of *cold-formed steel* members in bending (Section C3.1.4 of AISI S100) and compression (Section C4.2 of AISI S100). Commentary to AISI S100 provides detailed technical information on distortional buckling. In 2009, distortional buckling was introduced in this Standard, and separate provisions provided for discretely braced design and continuously braced design. Discrete braces must restrict rotation at the *web/flange* juncture. This may be accomplished with sufficiently stiff *blocking* to restrict

rotations in the *web*, with *strap* across a series of members lacing from compression *flange* of one member to the tension *flange* of the next member and continuing, or with other systems – engineering judgment is required. Provisions for continuously braced design for distortional buckling are provided in Section B2.6.

The Standard permits the design of wall *studs* to be based on either an all steel design in which discrete braces are provided along the member's length, or based on a sheathing braced design. Because load-bearing wall *studs* used in multi-story construction may go unsheathed for an extended period of time during construction, it is uncommon to use a sheathing braced design approach. It is permitted by this Standard to use sheathing attached to both *flanges*, or to use a combination of sheathing attached to one *flange* and discrete bracing stabilizing the other *flange*. When the *curtain wall stud* has sheathing only on one *flange* and discrete bracing on the other *flange*, the *nominal flexural strength [resistance]* is determined using the provisions of AISI S100 Section C3.1. When sheathing is attached to the compression *flange*, the lateral-torsional buckling does not need to be considered. Otherwise, the lateral-torsional buckling should be considered in accordance with AISI S100 Section C3.1.2. Distortional buckling should be considered whether or not the sheathing is attached to the compression *flange*. In 2015, the maximum discrete bracing spacing of 8 ft (2.44 m) on center is required based on design experience and common practice for flexural members such as *curtain wall studs*.

The Standard stipulates that when sheathing braced design is used, the wall *stud* shall be evaluated without the sheathing *bracing* for the dead loads and loads that may occur during construction, or in the event that the sheathing has been removed or has accidentally become ineffective. In 2014, the LRFD load combination for the United States and Mexico was taken from ASCE 7 (ASCE, 2006) for special event loading conditions.

Although the design approach for sheathing braced design is based upon engineering principles, the Standard limits the sheathing braced design to wall *stud* assemblies, assuming that identical sheathing is attached to both sides of the wall *stud*. This limit recognizes that identical sheathing will aid in minimizing the twisting of the section. If only single-sided sheathing is used, additional twisting of the section will occur, thus placing a greater demand on the sheathing; therefore, the *stud* must be designed and braced as an all steel assembly.

The provision that wall *studs* with sheathing attached to both sides that is not identical shall be permitted to be designed based on the assumption that the weaker of the two sheathings is attached to both sides is based on engineering judgment. Determination of which of the two sheathings is weaker shall consider the sheathing strength, sheathing stiffness and sheathing-to-wall *stud connection* capacity, as applicable.

B1.2.3 In-Line Framing

In-line framing is the preferred and most commonly used framing method. The advantage of in-line framing is that it provides a direct load path for transfer of forces from *joists* to *studs*. The Standard stipulates maximum framing alignment to minimize secondary moments on the framing members. Weak axis bending strength of *track* is minimal, and therefore the *track* cannot function as a load transfer member. In the absence of in-line framing, a load distribution member, such as a structural *track*, may be required for this force transfer.

Industry practice has accepted in-line framing to mean that the *joist*, *rafter*, *truss* and structural wall *stud* framing would be aligned so that the center line (mid-width) is within

$\frac{3}{4}$ inch (19 mm) of the center line (mid-width) of the load-bearing members beneath. However, the $\frac{3}{4}$ inch allowable offset creates the possibility for a misalignment in the load path from an upper story load bearing *stud* wall, through a *joist* with a *bearing stiffener*, and onto a load-bearing *stud* or foundation wall below. In 2003, a total of 110 end- and interior-two-flange loading tests of various floor *joist* assemblies were carried out at the University of Waterloo (Fox, 2003) to determine the effect that an offset loading has on the strength of typical floors. It was concluded that an additional limit should be placed on the *bearing stiffener* offset to the load-bearing members above or beneath for cases where the *bearing stiffener* is attached to the back of the *joist* as depicted in Figure B1.2.3-1.

As an alternative to in-line framing, the Standard permits the use of a structural load distribution member that is specified in accordance with an *approved* design or *approved* design standard. As an aid to designers, strength and stiffness have been determined experimentally for various load-bearing top *track* assemblies (NAHB-RC, 2003; Dawe, 2005), including standard steel *track*, deep-leg steel *track*, and steel *track* with a 2x wood top plate. Design guidance for some of the typical top *track* load distribution members is available from the Cold-Formed Steel Engineers Institute (CFSEI, 2010a).

B1.2.5.2 Principles of Mechanics

The Standard does not aim to limit *cold-formed steel* light-framed *shear walls*, *strap braced walls* and *diaphragms* to the configurations included in the Standard. As such, the development of design values for other systems or configurations is permitted in accordance with rational engineering procedures and principles of mechanics. Design values based on calculations must, however, recognize the fundamental differences between the expected performance of structures under wind and seismic *loads*, and the performance of an individual lateral element. It must also be recognized that the tabulated design values in the Standard are based on test data for individual lateral elements. Recognition of these differences requires, where appropriate, that calculated values be scaled per existing design data. For wind design, there is no modification in design loads per the lateral resisting system used.

B1.3 Built-Up Sections

In 2007, a prescriptive end *connection* requirement for built-up compression members was added in Section D1.2 (2) of AISI S100 (AISI, 2007a) to preclude any shear slip in a built-up cold-formed steel section. This requirement was adopted from the AISC E6.2 (AISC, 2005a) and CAN/CSA S16.1 (CSA, 1994) structural steel specifications.

In order to determine the applicability of this prescriptive end *connection* requirement for double back-to-back *cold-formed steel studs*, a series of tests were conducted at the University of Missouri-Rolla (UMR). This research by Stone and LaBoube (2005) demonstrated that when a built-up *stud* is seated in a *track* section and bears on a firm surface, end slip is precluded; and thus the need for the additional fasteners is not required. The UMR research consisted of 32 tests of two C-shaped sections with edge stiffened *flanges*. The built-up sections tested were 82.6 inches (2.1 m) long, between 3-5/8 inches (92 mm) and 6 inches (152 mm) in depth, and between 33 mils (0.84 mm) and 54 mils (1.37 mm) thick. The *studs* were attached back-to-back with two rows of screws through the *web* starting 2 inches (50 mm) from each end and spaced at 12 inches (305 mm), 24 inches (610 mm) or 36 inches (914 mm) on-center. Each end of the built-up *stud* section was screwed to a standard track section 12 inches long which in turn was bearing on a 6" x 8" x $\frac{1}{2}$ " (152mm x 203 mm x 12.7 mm) steel bearing plate. In order to simulate a pin *connection* representing an effective length factor of

unity, the steel bearing plate at each end was supported on a round bar.

In order to justify not specifying the end *connection* requirement of Section D1.2(b) of AISI S100, the designer must meet the bearing condition of support on steel or concrete to ensure relative slip of the two sections is prevented. This requires that the *track* must be supported over the entire area of the built-up member by steel or concrete components and that bearing stresses on the steel or concrete are within allowable limits.

B1.5 Connection Design

Self-drilling screws are the primary fastener type used in cold-formed steel construction, although the Standard does not preclude the use of other fastener types.

B1.5.1 Screw Connections

B1.5.1.1 Steel-to-Steel Screws

Screws are the primary fastener type used in *cold-formed steel* framed construction, although the Standard does not preclude the use of other fastener types. ASTM C1513 (ASTM, 2013) covers screws for the *connection of cold-formed steel* members manufactured in accordance with ASTM Specifications C645 and C955. This specification also covers test methods for determining performance requirements and physical properties. However, the tensile or shear strength must be determined by test in accordance with AISI S904 (AISI, 2013). General guidance on the selection of screws is given by the Cold-Formed Steel Engineers Institute document *Screw Fastener Selection for Cold-Formed Steel Frame Construction* (CFSEL, 2011).

Proper selection and installation of screws is necessary to ensure the design performance. Screws are specified using a nominal size designator, not by diameter. Table C-B1.5.1.1-1 defines suggested nominal screw diameters. The installation requirements stated in this Standard are based on industry practice. Selection of a minimum screw size is based on the total sheet thickness of the *connection*. Where recommendations are not available, Table C-B1.5.1.1-2 provides suggested screw size for steel-to-steel *connections* as a function of point style, per ASTM C1513, and total combined thickness of all connected steel members.

**Table C-B1.5.1.1-1
Suggested Screw Body Diameter**

Screw Nominal Size	Nominal Screw Diameter, d	
	(inches)	(mm)
No. 6	0.138	3.51
No. 8	0.164	4.17
No. 10	0.190	4.83
No. 12	0.216	5.49
1/4"	0.250	6.35



Table C-B1.5.1.1-2
Suggested Screw Sizes For Steel-to-Steel Connections

Screw Size	Point Style	Total Thickness of Steel ¹	
		(inches)	(mm)
¼"	1	0.024 - 0.095	0.61 - 2.41
No. 6	2	0.036 - 0.100	0.91 - 2.54
No. 8	2	0.036 - 0.100	0.91 - 2.54
No. 10	2	0.036 - 0.110	0.91 - 2.79
No. 12	2	0.050 - 0.140	1.27 - 3.56
No. 14	2	0.060 - 0.120	1.52 - 3.05
No. 18	2	0.060 - 0.120	1.52 - 3.05
No. 8	3	0.100 - 0.140	2.54 - 3.56
No. 10	3	0.110 - 0.175	2.79 - 4.45
No. 12	3	0.090 - 0.210	2.29 - 5.33
No. 14	3	0.110 - 0.250	2.79 - 6.35
No. 12	4	0.175 - 0.250	4.45 - 6.35
¼"	4	0.175 - 0.250	4.45 - 6.35
No. 12	4.5	0.145 - 0.312	3.68 - 7.92
No. 12	5	0.250 - 0.500	6.35 - 12.7
¼"	5	0.250 - 0.500	6.35 - 12.7

¹ Combined thickness of all connected steel members

B1.5.1.3 Spacing and Edge Distance

AISI S100 [CSA S136] (AISI, 2012a; CSA, 2012) stipulates that the center-to-center spacing of screws be at least 3 times the screw diameter. During installation, if this spacing is only 2 times the diameter, research at the University of Missouri-Rolla (Sokol et al., 1999) has shown that the structural performance of the *connection* is reduced. Guidelines for center-to-center spacing of less than 2 times the diameter are not stipulated because the screw head diameter precludes a smaller spacing. The University of Missouri-Rolla research serves as the basis for the requirements in the Standard.

B1.5.1.4 Gypsum Board

The Standard employs the use of the *applicable building code* as the guide for provisions that cover the installation and attachment of gypsum panels to *cold-formed steel* framing. The model building codes in the United States reference ASTM C1007 (ASTM, 2011d) as the appropriate standard for the gypsum board attachment to *cold-formed steel structural members*.

The Standard requires that screw fasteners for gypsum board to steel *connections* be in compliance with ASTM C954 (ASTM, 2011a), ASTM C1002 (ASTM, 2014a) or ASTM C1513 (ASTM, 2013), as applicable, with a bugle head style. ASTM C954 is for fastening to steel having a thickness from 0.033 inches (0.84 mm) to 0.112 inches (2.84 mm). ASTM C1002 is for fastening to steel with a thickness less than 0.033 inches (0.84 mm). ASTM C1513 is for fastening to steel with a thickness not greater than 0.118 inches (2.997 mm).

B1.5.2 Welded Connections

Additional guidance on welding of *cold-formed steel* members is provided in the Cold-Formed Steel Engineers Institute document *Welding Cold-Formed Steel* (CFSEI, 2010b).

B1.5.3 Bolts

The Standard permits the use of bolts. Bolted *connections* can be designed by AISI S100 [CSA S136] equations.

B1.5.4 Power-Actuated Fasteners

The Standard permits the use of power-actuated fasteners. *Connections* using power-actuated fasteners can be designed by AISI S100 [CSA S136] equations.

B1.5.5 Other Connectors

The Standard permits the use of proprietary fasteners such as pneumatically driven pins, rivets, adhesives, and clinches. Proprietary fasteners must be designed and installed in accordance with the manufacturers' requirements. The *safety factor* to be used in design is to be determined by Chapter F of AISI S100 [CSA S136]. The Cold-Formed Steel Engineers Institute has published technical notes pertaining to power-actuated fasteners and pneumatically driven pins (CFSEI, 2012; CFSEI, 2009).

B2 Floor and Ceiling Framing

B2.5 Bearing Stiffeners

The Standard provides provisions for clip angle bearing stiffeners, based on research at the University of Waterloo (Fox, 2006).

B2.6 Bracing Design

The continuous bracing and *flange* bracing provisions of the Standard were deemed appropriate due to the availability of research and field experience with such assemblies. The requirements in Section B2.6 were adapted from AISI S100 [CSA S136] requirements for members where neither *flange* is attached to sheathing.

B3 Wall Framing

B3.2 Wall Stud Design

B3.2.1 Axial Load

Prior to 2004, the *North American Specification for the Design of Cold-Formed Steel Structural Members* contained requirements for sheathing braced design in its Section D4(b). In 2004, these provisions were removed. AISI S100 [CSA S136], (AISI, 2012a; CSA, 2012) now permits sheathing braced design in accordance with an appropriate theory, tests, or *rational engineering analysis*.

Sheathing braced design in the Standard is based on rational analysis assuming that the sheathing braces the *stud* at the location of each sheathing-to-*stud* fastener location. Axial load in the *stud* is limited, therefore, by the capacity of the sheathing or sheathing-to-wall *stud connection*. Using the bracing principles as defined by Winter (1960) and summarized

by Salmon and Johnson (1996), the equilibrium of an imperfect column braced at mid-height, as illustrated in Figure C-B3.2.1-1, is expressed as:

$$P(\Delta+\Delta_0)=k \frac{\Delta}{2} \frac{L}{2} \quad (\text{C-B3.2.1-1})$$

where

Δ = Sidesway deflection at brace location beyond initial imperfection, Δ_0

Δ_0 = Initial imperfection

L = Total *stud* height

k = Bracing stiffness

Following Eq. C-B3.2.1-1 to solve for deflection, Δ :

$$\Delta = \frac{P\Delta_0}{\frac{kL}{4} - P}$$

When P approaches $kL/4$, the lateral deflection approaches infinity. Therefore, $P_{cr}=kL/4$. The bracing stiffness corresponding to P_{cr} is called k_{ideal} , and $k_{ideal} = 4P_{cr}/L$. To provide sufficient bracing to a column subjected to load P , k needs to be greater than k_{ideal} . It is common to choose $k = 2k_{ideal} = 2(4P/L)$, and the corresponding deflection is:

$$\Delta = \frac{P\Delta_0}{\frac{kL}{4} - P} = \frac{P\Delta_0}{2\left(\frac{4P}{L}\right)\frac{L}{4} - P} = \Delta_0$$

For $\Delta_0 = L/960$, the bracing force is

$$F_{br} = k\Delta = 2\frac{4P}{L}\Delta_0 = 0.8\%P$$

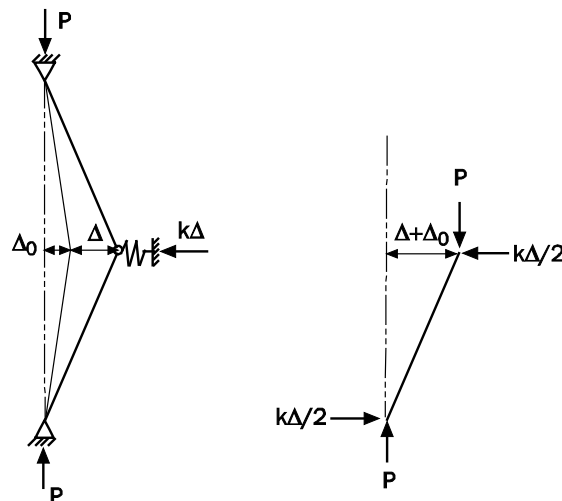

Figure C-B.2.1-1 Column Lateral Bracing

This result is consistent with the requirement of 1% P from AISI S100 Equation D3.3-1. In this Standard, a more conservative approach has been taken by considering a safety factor of 2, which results in $F_{br} = 2\%P$. Since the tests indicated a failure of the sheathing, not the screw-to-*stud* attachment, the Standard does not directly stipulate a design requirement to check the screw-to-*stud* capacity or the screw capacity in shear.

The strength of gypsum sheathing attached with No. 8 and No. 6 screws is based on

tests by Miller (1989) and Lee (1995), respectively. Based on engineering judgment, a factor of safety of 2.0 was applied to the ultimate load per screw (Table C-B3.2-1) when determining the brace strength per screw for the gypsum wallboard. The ultimate loads are based on the averaging of test data provided in Miller (1989) and Lee (1995).

Table C-B3.2-1
Brace Strength [Resistance] Per Screw
Limited by Gypsum Sheathing-to-Wall Stud Connection Capacity

Sheathing	Screw Size	Ultimate Load (per screw)	Brace Strength [Resistance](per screw)
1/2 inch (12.7 mm)	No. 6	0.117 kips (0.516 kN)	0.058 kips (0.258 kN)
1/2 inch (12.7 mm)	No. 8	0.134 kips (0.596 kN)	0.067 kips (0.298 kN)
5/8 inch (15.9 mm)	No. 6	0.136 kips (0.605 kN)	0.068 kips (0.302 kN)
5/8 inch (15.9 mm)	No. 8	0.156 kips (0.694 kN)	0.078 kips (0.347 kN)

The maximum axial nominal load provided in Table B3.2-1 of the Standard was determined by first multiplying the brace strength [*resistance*] per screw given in Commentary Table C-B3.2-1 by 2 to recognize that sheathing must be attached to both *stud flanges* and then dividing by 0.02 (i.e., 2%P), thus solving for the nominal load P that is given in Table B3.2-1 of the Standard.

The unbraced length with respect to the minor axis and the unbraced length for torsion are taken as twice the distance between the sheathing connectors in the event that an occasional attachment is defective to a degree that it is completely inoperative.

If plywood sheathing is attached to both *flanges* of the wall *stud* by screws spaced no greater than 12 inches (305 mm) on center, both the plywood and the *stud* must be checked. The following outlines a possible design solution for plywood attached to a wall *stud*:

Evaluation of the Plywood:

Using NDS (AFPA, 1997) Section 11.3,

Nominal Design Value (Brace Strength), $Z = D \ell_m F_{em} / R_d$

$D = 0.164''$ (4.17 mm) (No. 8 Screw)

$\ell_m =$ Sheathing thickness = 0.5'' (12.7 mm)

$R_d = 2.2$ for $D \leq 0.17''$ (4.32 mm)

$F_{em} = 1900$ psi (13,100 kPa) (lowest bearing strength value – the values are based on the specific gravity of the wood)

$Z = 0.164 \times 0.5 \times 1900 / 2.2 = 70.82$ lbs. (315 N)

Brace Force, $F_{br} = 0.02 P$, where P is the axial load in the *stud*.

$P = 70.82 / 0.02 = 3,540$ lbs (15,700 N) = 3.5 kips (15.6 kN) per screw x 2 screws = 7.0 kips (31.1 kN) per *stud*

Evaluation of the Steel Wall Stud:

The screw capacity in the *stud* can be evaluated using Section E4.3 of AISI100 [CSA S136],

where

$P_{ns} = 4.2 (t^3 d)^{0.5} F_u \leq 2.7 t d F_u$

$\Omega = 3.0$

If $P_{ns} / \Omega < Z$, the brace force analysis to determine P should be based on the lower

value. The capacity per screw is computed by the following equation:

$$P = (P_{ns}/\Omega < Z)/0.02$$

Because the Standard requires that sheathing must be attached to both *flanges* of the wall *stud*, the *nominal* axial load in the wall *stud* is twice the value of P.

B3.2.5 Web Crippling

B3.2.5.1 Stud-to-Track Connection for C-Section Studs

When the *track* thickness is equal to or greater than the *stud* thickness, an increase in *web* crippling strength can be realized. This increased strength is attributed to the favorable synergistic effect of the *stud-to-track* assembly. The provisions are based on research conducted at the University of Waterloo (Fox and Schuster, 2000) and the University of Missouri-Rolla (Bolte, 2003).

Two proposed design equations were considered for adoption by Section B3.2.5.1 of the Standard for evaluating the design strength of the *stud-to-track connection* for *curtain wall* applications. The proposed UMR equation (Bolte, 2003) reflected the specific contribution of the screw as follows:

$$P_{nst} = P_n + \alpha P_{not} \quad (\text{C-B3.2.5.1-1})$$

where

$$\alpha = 0.756$$

P_n = *Web* crippling capacity in accordance with Section C3.4.1 of AISI S100 [CSA S136] for end one-*flange* loading

P_{nst} = *Nominal strength [resistance]* for the *stud-to-track connection* when subjected to transverse loads

P_{not} = Screw pull-out capacity in accordance with Section E4.4.1 of AISI S100 [CSA S136]

The proposed equation (C-B3.2.5.1-2) was based on a formulation proposed by Fox and Schuster (2000). The design formulation for the *stud-to-track connection* was based on a pure *web* crippling behavior consistent with Section C3.4 of AISI S100 [CSA S136]. To reflect the positive contribution of the screw attachment, Fox and Schuster (2000) proposed modified *web* crippling coefficients as follows:

$$P_n = Ct^2F_y \sin\theta \left(1 - C_R \sqrt{\frac{R}{t}} \right) \left(1 + C_N \sqrt{\frac{N}{t}} \right) \left(1 - C_h \sqrt{\frac{h}{t}} \right) \quad (\text{C-B3.2.5.1-2})$$

where

P_n = *Nominal web* crippling strength [resistance] per Section C3.4.1 of AISI S100 [CSA S136] with the following coefficients:

C = *Web* crippling coefficient = 5.6

C_R = Inside bend radius coefficient = 0.01

C_N = Bearing length coefficient = 0.30

C_h = *Web* slenderness coefficient = 0.14

R = *Stud* inside bend radius

N = *Stud* bearing length

h = Depth of flat portion of *stud web* measured along plane of *web*

t = *Stud* design thickness

θ = Angle between plane of *web* and plane of bearing surface, $45^\circ < \theta \leq 90^\circ$

Based on the additional tests performed at UMR and the University of Waterloo, the following coefficients are recommended:

C = *Web* crippling coefficient = 3.7

C_R = *Web* slenderness coefficient = 0.19

C_N = Bearing length coefficient = 0.74

C_h = Inside bend radius coefficient = 0.019

Although there are pros and cons to each design equation, statistically they yield similar results as shown in the following:

Table B3.2.5.1-1
Comparison of Proposed Design Equations

Parameter	Waterloo Model	UMR Model
Mean	1.001	1.000
Coeff. of Variation	0.101	0.078
Ω	1.74	1.71
ϕ (LRFD)	0.88	0.90

The *safety factor* and *resistance factor* are based on assuming a member failure mode, not a *connection* failure mode.

Although both the UMR and University of Waterloo design methods will yield similar design strengths, for simplicity of design it was decided to adopt the University of Waterloo design method for the Standard. For simplicity, since $\theta = 90^\circ$ and therefore $\sin\theta = 1$, the $\sin\theta$ term was eliminated from Equation B3.2.5.1-1.

When the *track* thickness is less than the *stud* thickness, the proposed provisions are based on the study by Fox and Schuster (2000).

The 0.5 applied to P_{nst} for locations adjacent to wall openings is based on a study by Daudet (2001).

Further research on these *stud-to-track connections* was carried out in 2008 at the University of Waterloo (Lewis, 2008), with the objective being to extend the design provisions in Section B3.2.5.1 of the Standard to cover jamb *stud* members. These jamb *studs* can be single *C-shaped* members or built-up sections made from multiple members. The scope of testing was limited to the following:

1. Single *C-shaped stud* members located at the end of the *track* with two orientations of the *stud*: with the stiffening lips adjacent to the *track* end, and with the *stud web* adjacent to the *track* end.
2. Two *C-shaped studs* connected back-to-back, positioned in the *track* away from the *track* end, and positioned at the end of the *track*.
3. Two *C-shaped studs* connected toe-to-toe, positioned in the *track* away from the *track* end, and positioned at the end of the *track*.

The research showed that the *web* crippling expression in the Standard can be applied to all other combinations of single *C-shaped* and built-up members simply by changing the global *web* crippling coefficient, C . It was determined that the strength of other jamb *stud* configurations were multiples of the $C=3.7$ for a single *stud*. For example, a single member at the end of a *track* is $0.5C = 1.85$; toe-to-toe or back-to-back

members are $2C = 7.40$; toe-to-toe members at the *track* end are $1.5C = 5.55$; and single *stud* at the *track* end with the stiffening lips adjacent to the opening are $0.75C = 2.78$. These results can only be applied within the range of the test parameters. For the *web* crippling failure mode to occur, the screws connecting the *stud*-to-*track* need to be sized according to the *stud* thickness. Provisions have been added for minimum screw sizes for the various *stud* thicknesses.

These tests were limited to combinations of *stud* and *track* where the *track* was the same thickness as the *stud*. This avoided the possibility of a *track* punch-through failure for the single *C-shaped studs* and for the toe-to-toe built-up members, but not for the back-to-back members. Consequently, a new design limit state for the *track* punch-through failure mode is proposed for the back-to-back built-up jamb members.

In situations where the back-to-back jamb *stud* configurations do not have screws connecting both *flanges* to the *track*, the *web* crippling strength [*resistance*] of the *studs* must be calculated using the provisions of AISI S100 [CSA-S136]. Since the AISI S100 *web* crippling calculations for back-to-back built-up sections overestimate the *nominal strength* [*resistance*] of these jamb *studs*, the *nominal strength* [*resistance*] is calculated using twice the AISI S100 *web* crippling capacity for a single *web* member.

The *safety factors* and *resistance factors* were determined based on the test data. As a result, there are different factors for different jamb *stud* configurations.

B3.2.5.2 Deflection Track Connection for C-Section Studs

The provisions contained in the Standard apply to a C-section wall *stud* installed in a single *deflection track* application and are based on research at the Milwaukee School of Engineering (Gerloff, 2004). Based on this research, the load capacity [*resistance*] can be established by the equations in the Standard. The key parameters, as given by the equations, are illustrated by Figure C-B3.2.5.2-1.

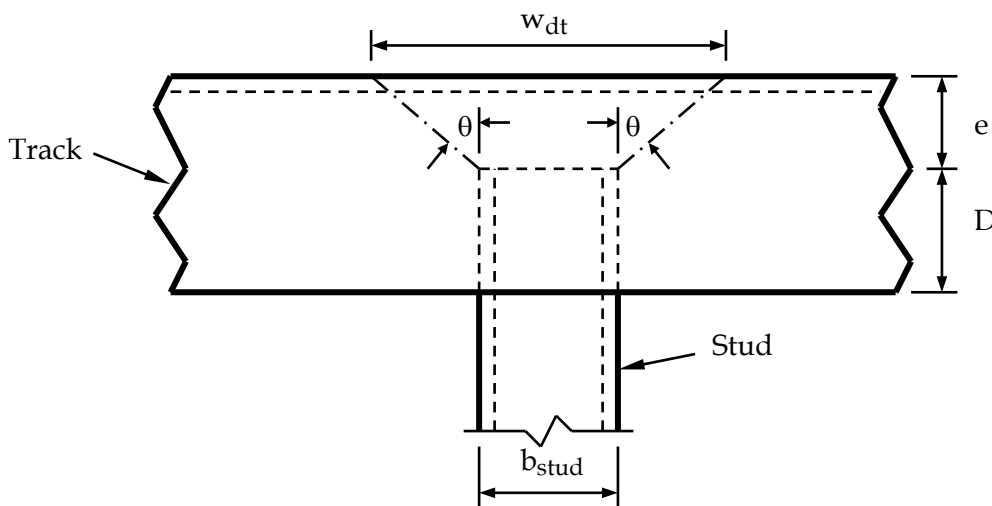

Figure C-B3.2.5.2-1 Deflection Track Connection

Because the *deflection track* detail does not provide torsional restraint for the wall *stud*, it is recommended that a line of bridging be installed near the end of the member.

For Figure C-B3.2.5.2-1, dimension “*e*” is selected for the sum of construction tolerances and the deflection of the floor above relative to the floor or foundation below. Dimension “*D*” is selected so that adequate *stud* to *track* engagement and *web* crippling

bearing length remain when the floor below deflects relative to the floor above.

The background research for this provision did not include *studs* at or near terminations in the top *track*. For this case, the strength and serviceability of the *connection* may be reduced.

B3.3 Header Design

Box and back-to-back *header* beams have been commonly used in *cold-formed steel* framing. The geometry is fabricated using two *C-shaped cold-formed steel* members. Design practice for such *header* beams can be based on AISI S100 [CSA S136], (AISI, 2012a; CSA, 2012). Research has determined that the application of AISI S100 [CSA S136] design provisions is conservative when *track* members are included in the assembly. This led to the development of an improved design methodology.

L-header beam geometries are gaining popularity in *cold-formed steel* framing. The geometry is fabricated using one or two L-shaped *cold-formed steel* members connected to a top *track* section. This geometry is commonly referred to as a single or double *L-header* because one or two angle shapes are used to create the *header*.

The *header* design provisions in the Standard do not attempt to provide a complete methodology for the design of openings in buildings. For such, the designer must consider numerous loading and serviceability issues (including out-of-plane loads) and design a complete load path consisting of members and *connections* that may include *cripple studs*, *jack studs*, *king studs*, *head tracks* and *sill tracks*. A useful reference for designers on this subject is the AISI *Cold-Formed Steel Framing Design Guide* (AISI, 2007).

B3.3.1 Back-to-Back Headers

The design methodology is based on review and analysis of the data presented in the NAHB (2003a) report *Cold-Formed Steel Back-To-Back Header Assembly Tests* (1997) and the study of Stephens (2000, 2001). The test results were evaluated and compared with the strength equations contained in the 2001 edition of the AISI Specification.

Stephens and LaBoube (2000) concluded that *web* crippling or a combination of bending and *web* crippling is the primary factor in *header* beam design for the IOF (interior one-flange) loading condition. Neither pure shear nor combined bending and shear were failure modes in the test program. The research study showed that using AISI S100 [CSA S136] *web* crippling equations for shapes having single *webs* for the design of box or back-to-back *header* beams gave conservative results.

B3.3.2 Box Headers

Based on studies conducted by Stephens (2001), a modification factor was derived that enables the computation of the interior one-flange *web* crippling capacity of a box *header* assembly as defined by Figure C3.4.4-2 of the Standard. The increased *web* crippling capacity is attributed to the interaction of the *track* section and the *C-shaped* section; thus, it is imperative that the *track* section be attached with the *flanges* as shown in Figure C3.4.4-2. This interaction is quantified by the ratio of *track* thickness to *C-shaped* section thickness in Eq. B3.3.2.3-1. When computing the *web* crippling capacity for a *header* assembly, the nominal capacity computed using AISI S100 [CSA S136] is to be multiplied by 2 to reflect that there are two *webs* in the assembly. In addition to a modification to the pure *web* crippling strength, the Standard also contains an interaction equation for bending and *web* crippling of box *header* assemblies that differs from AISI S100 [CSA S136]. This interaction

equation is based on the research of Stephens (2001), which included test specimens having standard perforations. Thus, the provisions of AISI S100 [CSA S136] are appropriate for *header* design.

If the top *track* section of a box *header* assembly is attached with the *flanges* up, as would be the case where the *header* beam is located directly above the opening and beneath the *cripple studs*, the provisions of Section B3.3.2.3 would not apply. *Web* crippling capacity and the combination of bending and *web* crippling should be evaluated by using Sections C3.4 and C3.5 of AISI S100 [CSA S136], and the equations for shapes having single unreinforced *webs* should be used.

The procedure to calculate the vertical deflection of a box or back-to-back *header* may be accomplished by using a composite assembly calculation, which would include the two *C-shaped* sections and the top and bottom *tracks*. However, to achieve full composite action, using this type of calculation would require an extensive (cost-prohibitive) fastener requirement between the *tracks* and the *C-shaped* sections; and therefore, it is more common to use a conservative estimate of the vertical deflection based on the full moment of inertia of the two *C-shaped* sections alone.

See Section B3.3.1, Back-to-Back Header, for additional information, as applicable.

B3.3.3 Double L-Headers

The available test data (Elhadj and LaBoube, 2000; and LaBoube, 2004) indicated that the failure mode was flexure or combination of flexure and *web* crippling. Neither pure shear nor combined bending and shear were failure modes in the test program. The tested moment capacity, M_t , was determined and compared with the computed moment capacity as defined by Section C3.1.1(a) of AISI S100 [CSA S136]. The *nominal flexural strength* [*resistance*] was computed using the following equation:

$$M_n = S_{xc} F_y \quad (\text{C-B3.3.3-1})$$

where

F_y = Measured *yield stress*

S_{xc} = Elastic section modulus of the effective section computed at $f = F_y$.

The section modulus of the compression *flange* was used for all computations.

It should be noted that the flexural strength is based on the section modulus of the compression *flange*; i.e., yielding of the shorter, horizontal leg of the angle. The inelastic reserve capacity of the longer, vertical leg is recognized and yielding in the extreme tensile fiber is not considered a limit state.

It should also be noted that when the design provisions of the Standard were developed, the elastic section modulus of the effective section was computed assuming that when the free edge of the element was in tension, Equations B2.3-3, B2.3-4 and B2.3-5 of AISI S100 [CSA S136] would apply regardless of the magnitude of h_o/b_o . Therefore, these assumptions are appropriate when calculating the elastic section modulus of the effective section using the Standard.

For typical *L-headers* having a geometry as defined by the limitations of Section B3.3.3, the performance of full-scale double *L-header* beam tests (Elhadj and LaBoube, 2000; and LaBoube, 2004) has shown that the limit states of shear, *web* crippling, bending and shear, and bending and *web* crippling need not be considered when designing an *L-header* beam. This is because shear and *web* crippling failures were not indicated in any of the tests, and because a simplified conservative design approach is used. *Web* crippling is effectively prevented by the way *L-headers* are assembled. However, designers are cautioned that an

L-header could potentially fail in shear for the combination of a very short span and a very large loading. Currently there are no limitations prescribed on minimum lengths or other factors that would prohibit shear failure in such cases. However, as a suggested procedure, shear should probably be considered when the span-to-depth ratio is less than 3.

The procedure to calculate the vertical deflection of an *L-header* is undefined because the *L-header* is an indeterminate assembly consisting of two angles, *cripple studs*, and *track* sections interconnected by self-drilling screws. However, the test results indicate that the measured assembly deflections at an applied load that equaled the *nominal load* [specified load] was less than $L/240$. Further analytical work, based on test data, would be necessary in order to develop a calculation procedure to determine the deflection of *L-header* beams.

B3.3.3.1.1 Gravity Loading

The test results summarized by Elhadj and LaBoube (2000) and LaBoube (2004) are considered to be confirmatory tests that show AISI S100 [CSA S136] Section C3.1.1 provides an acceptable determination of the *nominal flexural strength* [resistance].

For the 10-inch (254-mm)-deep *L-header* beams having the span to vertical leg dimension, L/L_h , greater than 10, the tested *header* sections had tested moment capacities greater than the computed moment capacity defined by Eq. B3.3.3.1.1-1 in the Standard. However, for 10-inch (254-mm)-deep beams having L/L_h ratios less than 10, the tested moment capacity was on the average 10% less than the computed moment capacity (Elhadj and LaBoube, 2000). Thus, the application of Eq. B3.3.3.1.1-1 is questionable for full range of the 10-inch (254-mm) *L-headers*. A review of the data indicates that the application of Eq. B3.3.3.1.1-1 is valid for test specimens having a span to vertical leg dimension, L/L_h , of 10 or greater. For the specimens having L/L_h ratios less than 10, it is proposed that the results obtained by using Eq. B3.3.3.1.1-1 be multiplied by 0.9.

B3.3.3.1.2 Uplift Loading

A comparison of the tested to computed moment capacity ratios ranged from 0.141 to 0.309 with a mean of 0.215 (Elhadj and LaBoube, 2000). Further analysis of the tested to computed moment ratios indicated that the behavior was influenced by the ratio of L_h/t . Therefore, uplift reduction factors, R , in the Standard were developed as a function of the L_h/t ratio.

Based on the provisions of Chapter F of AISI S100 [CSA S136], the *safety factor* was computed to be 2.0.

B3.3.4 Single L-Headers

Prior to 2003, the Standard excluded single *L-headers*. The NAHB Research Center (2003a) study that was completed prior to 2003 tested both single and double *L-header* beams. The tests consisted of either a single-point load or a two-point load. All angles had a 1.5 inch (38.1 mm) top *flange*. The vertical leg dimensions were either 6, 8, or 10 inches (152, 203 or 254 mm). Thicknesses ranged from nominally 0.033 to 0.068 inches (0.84 to 1.73 mm). Test span lengths ranged from 36 to 192 inches (914 to 4880 mm).

An analysis of the data indicated that the behavior of the *L-headers* differed for single-versus double-angle geometries. Also, the single-point load produced test results that differed from the two-point load. Prior to 2003, there was insufficient data to develop design guidelines for single-angle *L-headers*. Thus, the data analysis did not consider data

for the single-angle sections nor for the single-point loading.

In 2003, testing was completed at the NAHB Research Center (2003a) on single *L-header* beams. The tests were similar to the previously tested double *L-header* beam tests, but *header* sizes were limited to vertical leg dimensions of 6 and 8 inches (152 or 203 mm), thicknesses ranged from nominally 0.033 to 0.054 inches (0.84 to 1.37 mm), and spans were limited to 4 feet (1.219 m). From this testing, sufficient data was provided to develop design guidelines for single *L-headers* within the range of parameters tested.

LaBoube (2004), based on testing by the NAHB Research Center (2003a), demonstrated that the design methodology for double *L-headers* in the 2001 edition of the *AISI Standard for Cold-Formed Steel Framing – Header Design* was acceptable for evaluating the gravity moment capacity of single *L-headers*, within the limitations of the test program. Uplift tests on single *L-headers* were not performed as part of this test program; however, Section B3.3.4.1.2 has been reserved in the Standard for this eventuality. Further, using the provisions of Section F1 of AISI S100 [CSA S136], the same Ω and ϕ factors that were prescribed in the 2001 edition of the *AISI Standard for Cold-Formed Steel Framing – Header Design* for the design of double *L-headers* would apply to single *L-headers*. As with previously tested double *L-headers*, neither pure shear nor combined bending and shear were failure modes for the tested single *L-headers*. Also, *web* crippling and combined bending and *web* crippling would be precluded from occurring because of the requirement that concentrated load applications occur at *cripple stud* locations.

B3.3.5 Inverted L-Header Assemblies

In 2005, provisions for inverted *L-headers*, as shown in Figure C-B3.3.5-1, were added to the Standard, based on rational engineering judgment, as a means to provide improved capacity for double and single *L-headers*.

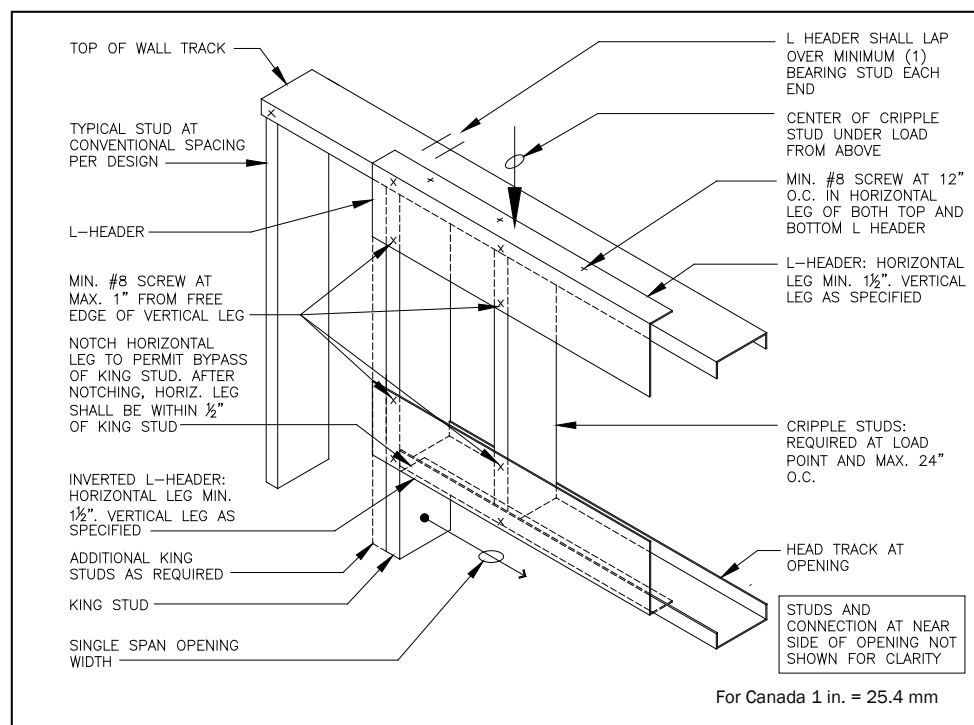

**Figure C-B3.3.5-1 Inverted Single or Double L-Header Assembly
(Inverted Single L-Header Shown)**

B3.4 Bracing

The requirement in the Standard that each brace be designed for 2% of the design compression load [force] in the member is based on a long-standing industry practice. See further discussion in Commentary Section B3.2.1.

Bracing requires periodic anchorage. Bracing forces are accumulative between anchorage points.

B3.4.1 Intermediate Brace Design

Brace forces are additive, thus the Standard requires consideration of combined brace forces that when designing braces for members that experience combined loading. Design guidance is provided in AISI D110 (AISI, 2007).

B3.5 Serviceability

The Standard does not stipulate serviceability limit states. However, the *International Building Code* (ICC, 2015) sets forth deflection limits in Sections 1604.3 and 1405.10.3, and the *NFPA 5000* (NFPA, 2015) sets forth similar provisions in Section 35.1.2.8 for use in the United States and Mexico. Likewise, the *User's Guide - NBC 2010 Structural Commentaries (Part 4, of Division B)* (NRCC, 2010) sets forth deflection limits for use in Canada.

B4 Roofing Framing

B4.5 Bracing Design

The continuous bracing and *flange* bracing provisions of the Standard were deemed appropriate due to the availability of research and field experience with such assemblies. The requirements in Section B4.5(b) were adapted from AISI S100 [CSA S136] requirements for members where neither *flange* is attached to sheathing.

B5 Lateral Force-Resisting Systems

The lateral design provisions of the Standard were initially based on the requirements in the *International Building Code* (ICC, 2003) and the *NFPA 5000 Building Construction and Safety Code* (NFPA, 2003). The provisions in those codes evolved since the early work of Tarpay (1976-80), APA-The Engineered Wood Association (1993), Serrette (1995a) and the *shear wall* provisions that were first introduced into the 1997 *Uniform Building Code* (ICBO, 1997). Research conducted by Serrette at Santa Clara University and Dolan at Virginia Polytechnic Institute and State University form the technical basis for the initial design values in the Standard. Specific references to this research are cited in this *Commentary*. In 2007, provisions and design values related to *shear wall* and *strap braced wall* design, which are to be used with the 2005 *National Building Code of Canada* [NBCC] (NRCC, 2005), were added to the Standard based largely on research carried out under the supervision of Rogers at McGill University between 2005 and 2007. Specific references to this research are cited in the Commentary on ASI S400. At this time, the Standard does not address the Canadian design of *diaphragms*. Studies are ongoing, and it is expected that the Canadian design of these elements will be addressed in future editions of the Standard.

B5.2 Shear Wall Design

Shear walls are to be designed as either *Type I shear walls* or *Type II shear walls*.

B5.2.1 General

Type I shear walls are fully sheathed with *steel sheet sheathing*, *wood structural panels*, *gypsum board panels*, or *fiberboard panels* with *hold-downs* at each end. *Type I shear walls* sheathed with *steel sheet sheathing* or *wood structural panels* are permitted to have openings where details are provided to account for force transfer around openings. Figures C-B5.2.1-1(a) and C-B5.2.1-1(b) show typical *Type I shear walls*, with and without detailing for force transfer around window openings, and with *hold-down* anchors at the ends of each wall segment. Where wall assemblies are engineered for force transfer around openings and engineering analysis shows that uplift restraint at openings is not required, the assembly may be treated as a *Type I shear wall* and *hold-downs* are required at the ends of the assembly only, as illustrated in Figure C-B5.2.1-1(b).

Type II shear walls are sheathed with *steel sheet sheathing* or *wood structural panels* with a *Type II shear wall segment* at each end. Openings are permitted to occur beyond the ends of the *Type II shear wall*; however, the width of such openings shall not be included in the length of the *Type II shear wall*. Figure C-B5.2.1-2 shows a typical *Type II shear wall*.

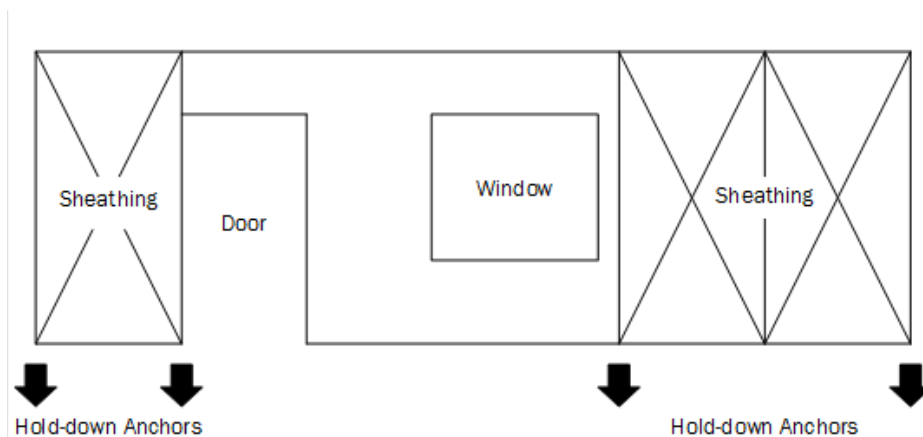

Figure C-B5.2.1-1(a) Type I Shear Walls Without Detailing for Force Transfer Around Openings

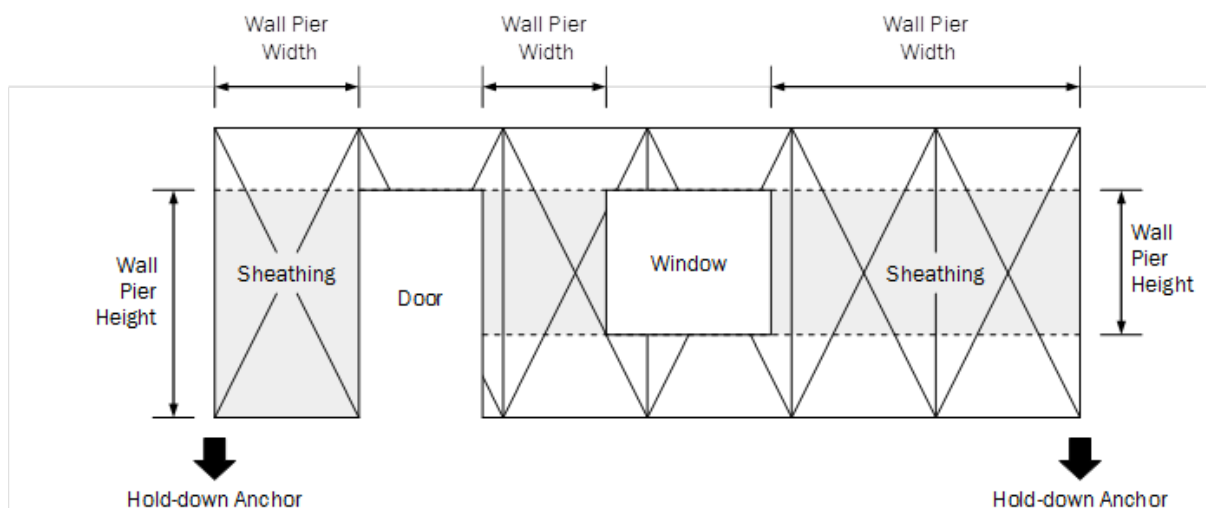

Figure C-B5.2.1-1(b) Type I Shear Wall With Detailing for Force Transfer Around Openings

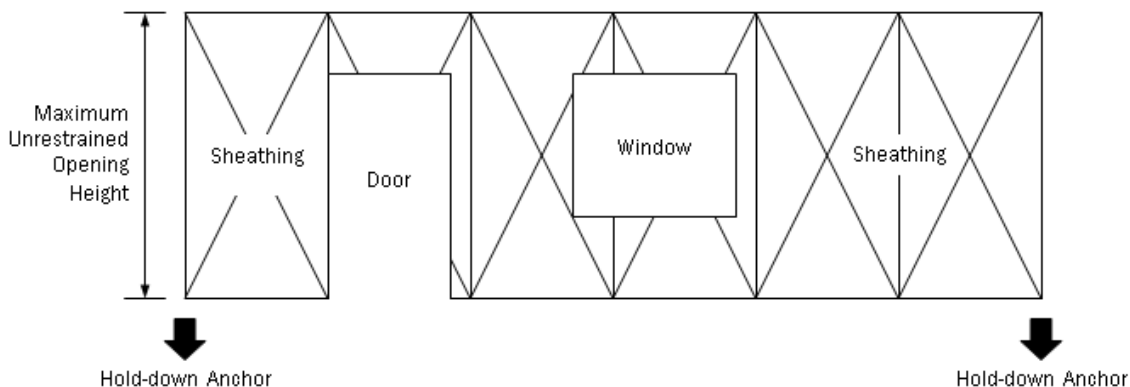

Figure C-B5.2.1-2 Typical Type II Shear Wall

B5.2.2 Nominal Strength [Resistance]

Since the tabulated values in the Standard are based on test data, it was deemed necessary to provide the user with the limiting values of the tested systems. The intent is not to prevent an engineer from using judgment, the principles of mechanics and supplemental data to develop alternate shear values from those shown in the Standard, as discussed in Section B1.2.5.2 above.

For both *wood structural panels* and *steel sheet sheathing*, aspect ratios up to 4:1 are permitted with reductions in *nominal strength*. The reduced strength values are conservative based on 4:1 aspect ratio tests conducted by Serrette (1997).

A *shear wall* assembly using an approved adhesive to attach *shear wall sheathing* to the framing is not yet recognized by this Standard or by ASCE 7. Sufficient test data to justify acceptance of *shear walls* that use adhesive alone or in combination with fasteners to attach sheathing to the framing members was not available at the time this Standard was written. The limited existing test data indicates that *shear walls* using adhesives for sheathing attachment will generally not perform the same as *shear walls* with only fasteners attaching the sheathing to the framing.

Overdriving of the sheathing screws will result in lower strength, stiffness and ductility of a *shear wall* compared with the values obtained from testing (Rokas, 2006); hence, sheathing screws should be firmly driven into framing members but not overdriven into sheathing.

B5.2.2.1 Type I Shear Walls

In the United States and Mexico: The initial requirements for *Type I shear walls* in the Standard were based on studies by Serrette (1996, 1997 and 2002). This series of investigations included reverse cyclic and monotonic loading and led to the development of the design values and details for plywood, oriented strand board (OSB), and gypsum wall-board (GWB) *shear wall* assemblies that are included in the Standard.

In the United States and Mexico: In 2006, requirements were established for *Type I shear walls* with *fiberboard* panel sheathing based on studies by the NAHB Research Center (NAHB, 2005) and by the American Fiberboard Association (PFS, 1996 and NAHB, 2006). The *nominal strength* values for *shear walls* faced with *fiberboard* in Table B5.2.2.3-4 were based on monotonic tests of *fiberboard* sheathed, *cold-formed steel* framed *shear walls* and were compared to the tests that are the basis of the building code

tabulated capacities for *fiberboard* sheathed, wood-framed *shear walls*. For the 2-inch (50.8 mm) and 3-inch (76.2-mm) edge screw spacing, the *nominal strength* values in Table B5.2.2.3-4 were based on the average peak load from tests of two 8-foot (2.438 m)-wide by 8-foot (2.428 m)-tall wall specimens. These *nominal strength* values were found to be within 90 percent of the *nominal strength* values for similarly sheathed wood-framed walls. The ratio of steel-to-wood *nominal strength* values increased as the edge (perimeter) fastener spacing increased and, therefore, extrapolating the 2/6 (92% ratio) and 3/6 (96% ratio) design values to 4/6 using a ratio of 90% was conservative. For the 4-inch (101.6 mm) edge screw spacing, the *nominal strength* values were calculated as 90 percent of the *nominal strength* value for a similarly sheathed wood-framed wall.

In the United States and Mexico: In 2011, the maximum aspect ratio of *shear wall* covered with 0.027" *steel sheet sheathing* on single side of the *shear wall* was established based on the experiments performed at the University of North Texas (Yu, 2007). In addition, the *nominal strength* values for 0.030" and 0.033" *steel sheet sheathing* on one side were added. The addition was also based on testing at the University of North Texas (Yu, 2007; Yu et al., 2009). *Designation thicknesses* of *stud*, *track* and *blocking*, and required sheathing screw size were added to the tables as well.

In the United States and Mexico: The Effective Strip Method for determining the *nominal shear strength* [resistance] for *Type I shear walls* with steel sheet sheathing is based on research by Yanagi and Yu (2014). The method assumes a sheathing strip carries the lateral load via a tension field action as illustrated in Figure C-B5.2.2.1-1. The shear strength of the shear wall is controlled by the tensile strength of the effective sheathing strip, which is determined as the lesser of the fasteners' tensile strength and the yield strength of the effective sheathing strip. The statistical analysis in Yanagi and Yu (2014) yielded an LRFD resistance factor of 0.79 for the Effective Strip Method. In order to keep consistency in resistance factors (0.65 for LRFD) specified in Standard Section B5.2.3, the original design equation in Yanagi and Yu (2014) was adjusted accordingly.

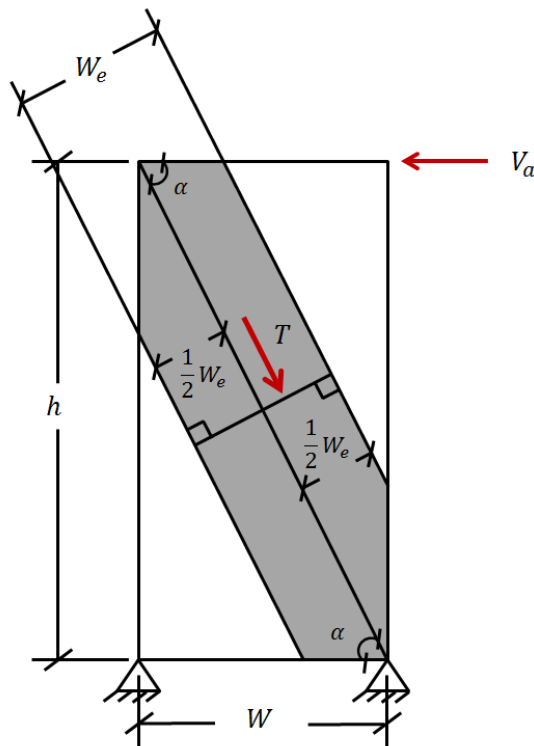

Figure C-B5.2.2.1-1 Effective Strip Method Model for Steel Sheet Sheathing

In the United States and Mexico: The nominal strengths [resistances] were based on tests with studs with 1.5-inch (38 mm) \times 4-inch (100 mm) punchouts at a center-to-center spacing of 24 inches (600 mm), anchor bolts with standard cut washers, and hold-down anchors on each end of the wall. As a result, the Standard permits the use of studs with standard punchouts and anchor bolts with standard cut washers, and requires hold-down anchors even though calculations may demonstrate that hold-down anchors are not necessary.

In the United States and Mexico: Factors were included, based on load duration factors given in the 2005 NDS (AFPA, 2005a) as shown in Table C-B5.2.2-1, to account for the influence of the duration of the applied load on wood strength to allow the tabulated values to be used for other in-plane lateral loads. Since the shear wall tests used as the basis of the Standard were carried out over a short time span, the tabulated values are for short-term duration loads (i.e., wind or seismic). However, the tabulated values for diaphragms were calculated using a load duration factor of 1.33, rather than the factor of 1.6 given in the 2005 NDS.

Table C-B5.2.2-1
United States and Mexico
AFPA NDS Load Duration Factors

Load Duration	Factor	Typical Design Loads
Permanent	0.9	Dead Load
Ten years	1.0	Occupancy Live Load
Two months	1.15	Snow Load
Seven days	1.25	Construction Load
Ten minutes	1.6	Wind/Earthquake Load

In Canada: Nominal resistance values for steel sheet sheathed and wood structural panel sheathed shear walls in AISI S240 match the values in AISI S400. Refer to the Commentary on AISI S400 for information on the derivation of these values. Nominal resistance values for gypsum and fiberboard sheathed shear walls in AISI S240 were set at 80% of the values found in Tables B5.2.2.3-3 and B5.2.2.3-4 for the United States. This reduction in resistance level is similar to what is found for the wood sheathed walls of similar construction, i.e. Table B5.2.2.3-2.

B5.2.2.2 Type II Shear Walls

The requirements for *Type II shear walls*, also known as perforated shear walls, in Section B5 were based on provisions in NEHRP (2000) for wood systems. In this method, the shear capacity ratio, F , or the ratio of the strength of a shear wall segment with openings to the strength of a fully sheathed wall segment without openings, is determined as follows:

$$F = \frac{r}{3 - 2r} \quad (\text{C-B5.2.2.2-1})$$

where

$$r = \frac{1}{1 + \frac{A_0}{h \sum L_i}} \quad (\text{C-B5.2.2.2-2})$$

A_0 = Total area of openings

h = Height of wall

$\sum L_i$ = Sum of the length of full-height sheathing

Research by Dolan (1999, 2000a, 2000b) demonstrated that this design procedure is as valid for steel-framed systems as for all wood systems, and the IBC (ICC, 2003) and NFPA 5000 (NFPA, 2003) building codes both permit the use of *Type II shear walls* for steel systems. Test results revealed the conservative nature of predictions of capacity at all levels of monotonic and cyclic loading. The Standard does not provide a method or adjustment factor for estimating the lateral displacement of *Type II shear walls*. As such, the user should be cautious if a *Type II shear wall* is used in a deflection-sensitive design.

Table B5.2.2.2-1 in the Standard, which establishes an adjustment factor for the shear resistance, is based on the methodology described in this section and exists in essentially the same form in both the wood and steel chapters of the IBC (ICC, 2003) building code. There is also a similar table in AISI S230 (AISI, 2012h); however, AISI S230 establishes an adjustment factor for the shear wall length rather than the shear wall resistance.

Although the Dolan work was based on wood structural panel sheathing, the Committee felt it was appropriate to extend this methodology to shear walls with steel sheet sheathing due to the similar performance of wood structural panel sheathing and steel sheet sheathing in monotonic and cyclic tests (Serrette, 1997) of *Type I shear walls*.

In accordance with Section B5.2.2.2 in the Standard, it is required to check the height/length ratio of each *Type II shear wall segment* and reduce the strength of each segment that has an aspect ratio greater than 2:1, but less than or equal to 4:1 by the factor of $2w/h$. This aspect ratio reduction factor is cumulative with the shear resistance adjustment factor, C_a .

B5.2.3 Available Strength [Factored Resistance]

In the United States and Mexico: With the adoption of AISI S400, *North American Standard for Seismic Design of Cold-Formed Steel Structural Systems*, the seismic requirements, including the *resistance factors*, ϕ , and *safety factors*, Ω , were eliminated from AISI S240. Seismic design using the provisions of AISI S240 are only permitted in Seismic Design Category A, or in Seismic Design Categories B or C if the Response Modification Factor, R , in accordance with ANSI/ASCE 7-10 Table 12.2-1, is equal to 3. For these conditions, where special seismic detailing is not required, the lower *resistance factor*, ϕ , and higher *safety factor*, Ω , typically required for seismic design, are not warranted.

In Canada: The *resistance factor* (ϕ) in AISI S240 matches the value in AISI S400. Refer to the Commentary on AISI S400 for information on the derivation of this value.

B5.2.5 Design Deflection

The deflection provisions are based on work performed by Serrette and Chau (2003). Equation C-B5.2.5-1 may be used to estimate the drift deflection of *cold-formed steel* light-framed *shear walls* recognized in the building codes. The equation should not be used beyond the *nominal strength* values given in the Standard. The method is based on a simple model for the behavior of *shear walls* and incorporates empirical factors to account for inelastic behavior and effective shear in the sheathing material. Specifically, the model assumes that the lateral deflection (drift) of a wall results from four basic contributions: linear elastic cantilever bending (*boundary member* contribution), linear elastic sheathing shear, a contribution for overall nonlinear effects, and a lateral contribution from anchorage/*hold-down* deformation. These four contributions are additive.

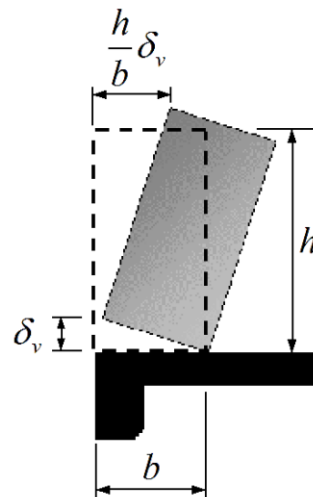

Figure C-B5.2.5-1 Lateral Contribution From Anchorage/Hold-Down Deformation

$$\delta = \frac{2vh^3}{3E_s A_c b} + \omega_1 \omega_2 \frac{vh}{\rho G t_{\text{sheathing}}} + \omega_1^{5/4} \omega_2 \omega_3 \omega_4 \left(\frac{v}{\beta} \right)^2 + \frac{h}{b} \delta_v \quad (\text{C-B5.2.5-1})$$

$$\text{Linear elastic cantilever bending: } \frac{2vh^3}{3E_s A_c b} \quad (\text{C-B5.2.5-2})$$

$$\text{Linear elastic sheathing shear: } \omega_1 \omega_2 \frac{vh}{\rho G t_{\text{sheathing}}} \quad (\text{C-B5.2.5-3})$$

$$\text{Overall nonlinear effects: } \omega_1^{5/4} \omega_2 \omega_3 \omega_4 \left(\frac{v}{\beta} \right)^2 \quad (\text{C-B5.2.5-4})$$

$$\text{Lateral contribution from anchorage/hold-down deformation: } \frac{h}{b} \delta_v \quad (\text{C-B5.2.5-5})$$

The lateral contribution from anchorage/*hold-down* deformation is dependent on the aspect ratio of the wall, as illustrated in Figure C-B5.2.5-1. The empirical factors used in the equation are based on regression and interpolation analyses of the reversed cyclic test data used in development of the *cold-formed steel shear wall* design values. The ρ term in the linear elastic sheathing shear expression attempts to account for observed differences in the response of walls with similar framing, fasteners and fastener schedules, but different sheathing material. Low values of ρ for *steel sheet sheathing* are a result of shear buckling in the sheet. The equations were based on *Type I shear walls* without openings, and the user should use caution if applying them to *Type I shear walls* with openings or to *Type II shear walls*. The *shear wall* deflection equations do not account for additional deflections that may result for other components in a structure (for example, wood sills and raised floors).

For wood structural panels, the shear modulus, G , is not a readily available value, except for Structural I plywood panels in the IBC (ICC, 2003) and UBC (ICBO, 1997) codes. However, the shear modulus may be approximated from the through thickness shear rigidity ($G_v t_v$), the nominal panel thickness (t) and through thickness panel grade and construction adjustment factor (C_G) provided in the AFPA Manual (AFPA, 2001). For example, G for 7/16-in. 24/16 OSB rated sheathing can be approximated as follows:

$$G_v t_v \text{ (24/16 span rating)} = 25,000 \text{ lb/inch (strength axis parallel to framing)}$$

$$t = 0.437 \text{ inch (as an approximation for } t_v)$$

$$C_G = 3.1$$

$$G \text{ (approximate)} = 3.1 \times 25,000 / 0.437 = 177,300 \text{ psi}$$

$$\text{Thus, } C_G G_v t_v = 77,500 \text{ lb/inch and } Gt = 77,500 \text{ lb/inch}$$

A comparison of the $C_G G_v t_v$ and Gt values suggests that using the nominal panel thickness as an approximation to t_v is reasonable given that the deflection equation provides an estimate of drift.

Currently, the *shear wall* deflection equations do not include provisions for gypsum board or *fiberboard shear walls*. However, the reader is reminded that given the low seismic response modification coefficient, R , assigned by the building codes to gypsum board *shear walls*, it is expected that these systems will perform in the elastic range of behavior and deflections will be less likely to control the design.

In 2012, coefficients β and ρ in deflection Equation B5.2.5-1 were revised for Canadian Soft Plywood (CSP), and *steel sheet sheathing*, based on research results compiled by Cobeen (2010). CSP was differentiated from other plywoods based on the performance of that material. It should be noted that Canadian Douglas Fir Plywood (DFP) was found to behave similarly to plywood in common use in the United States.

B5.3 Strap Braced Wall Design

For *strap braced walls*, it is acceptable to compute the deflection using standard engineering analysis. Deflection calculations should consider all elements that contribute to the horizontal top of wall displacement, including axial deformation of the *studs*, elongation of the *straps*, and a lateral contribution from anchorage/*hold-down* deformation, as well as additional deflections that may result for other components in a structure (for example, wood

sills and raised floors). Because loose *straps* permit lateral displacement without resistance, the Standard requires that *straps* be installed taut.

B5.4 Diaphragm Design

The Standard does not currently address the design of *diaphragms* in Canada; however, pending the completion of research that is currently underway, it is expected that the design of *diaphragms* in Canada will be addressed in a future edition.

B5.4.1 General

The Standard permits the use of *steel sheet sheathing*, concrete or *wood structural panels* or other *approved* materials to serve as the *diaphragm* sheathing.

B5.4.2 Nominal Strength

The *nominal strength* of *diaphragms* is to be based upon principles of mechanics, per Section B1.2.5.1. Alternatively, for *diaphragms* sheathed with wood structural panels, the *nominal strength* may be determined by Section B5.4.2. The design values for *diaphragms* with *wood structural panel* sheathing in Table B5.4.2-1 were based on work by Lum (LGSEA, 1998). Lum developed ASD design tables using an analytical method outlined by Tissell (APA, 1993; APA 2000) for wood framing and the provisions of the 1991 NDS (AFPA, 1991). Because steel is not affected by splitting or tearing when fasteners are closely spaced, no reduction in the calculated strength was taken for closely spaced fasteners. In addition, although steel with *designation thicknesses* greater than 33 mil resulted in higher strength values, no increase in strength was included for these greater thicknesses.

It should be noted that flat *strap* used as *blocking* to transfer shear forces between sheathing panels is permitted, but is not required to be attached to framing members.

It should be noted that the *diaphragm* design values by Lum were based on the *nominal strength* of a No. 8 screw attaching *wood structural panels* to 33-mil *cold-formed steel* framing members. The 1991 NDS calculation methodology, which was used by Lum, yielded a *nominal strength* of 372 lbs and a *safety factor* of 3.3. However, the NDS methodology was revised in 2001, and the revision greatly reduced the calculated strength of screw connections. Until Lum's work is updated, justification for maintaining the current *diaphragm* design values in the Standard are based, in part, on tests performed by APA (APA, 2005). Test results for single lap shear tests for a No. 8 screw attaching ½ in. plywood to 68-mil *steel sheet sheathing* indicated that the *nominal strength* [*resistance*] of the connection was governed by the strength of the screw in the *steel sheet sheathing*; i.e., the *wood structural panels* did not govern the capacity. Therefore, for thinner *steel sheet sheathing*, the *limit state* would likely be the tilting and bearing failure mode. For a No. 8 screw installed in 33-mil *steel sheet sheathing*, computations of connection capacity in accordance with AISI S100 [CSA S136] would yield a *nominal strength* of 492 lbs and a *safety factor* of 3.0. Additionally, connection tests for plywood attached to 33-mil *cold-formed steel* framing members were performed by Serrette (1995b) and produced an average ultimate connection capacity of 1177 lbs, and Serrette suggested the use of a *safety factor* of 6, as given by APA E380D. A review of the *allowable strengths*, as summarized in Table C-B5.4.2-1, indicates that although Lum's design values are based on an earlier edition of the NDS, the value is conservative when compared to both AISI's and Serrette's results.

Table C-B5.4.2-1
No. 8 Screw Shear Strength (lbs) for 33-mil Cold-Formed Steel Member

Lum		AISI 2001		Serrette	
Nominal	Allowable	Nominal	Allowable	Nominal	Allowable
372	112	492	164	1177	196

B5.4.4 Design Deflection

The methodology for determining the design deflection of *diaphragms* was based on a comparison of the equations used for estimating the deflection of wood frame *shear walls* and *diaphragms*, coupled with similarities in the performance of *cold-formed steel* and wood frame *shear walls*. Collectively, these comparisons suggested that the wood frame *diaphragm* equation could be adopted, with modifications to account for the difference in fastener performance, for application to *cold-formed steel* light-frame construction. The current equation for wood frame construction (ICC, 2003) is as follows:

$$\Delta = \frac{5vL^3}{8EAb} + \frac{vL}{4Gt} + 0.188Le_n + \frac{\sum(\Delta_c X)}{2b} \quad (\text{C-B5.4.4-1})$$

$$\text{For SI: } \Delta = \frac{0.052vL^3}{EAb} + \frac{vL}{4Gt} + \frac{Le_n}{1627} + \frac{\sum(\Delta_c X)}{2b} \quad (\text{C-B5.4.4-2})$$

where

A = Area of *chord* cross-section, in square inches (mm²)

b = *Diaphragm* width, in feet (mm)

E = Elastic modulus of *chords*, in pounds per square inch (N/mm²)

e_n = Nail deformation, in inches (mm)

G = Modulus of rigidity of wood structural panel, in pounds per square inch (N/mm²)

L = *Diaphragm* length, in feet (mm)

t = Effective thickness of wood structural panel for shear, in inches (mm)

v = Maximum shear due to design *loads* in the direction under consideration, in pounds per linear foot (N/mm)

Δ = The calculated deflection, in inches (mm)

Σ(Δ_cX) = Sum of individual *chord*-splice values on both sides of the *diaphragm*, each multiplied by its distance from the nearest support

Equations C-B5.4.4-1 and C-B5.4.4-2 apply to uniformly nailed, blocked *diaphragms* with a maximum framing spacing of 24 inches (610 mm) on center. For unblocked *diaphragms*, the deflection must be multiplied by 2.50 (APA, 2001). If not uniformly nailed, the constant 0.188 (For SI: 1/1627) in the third term must be modified accordingly.

In 2012, coefficients β and ρ in deflection Equation B5.2.5-1 were revised based on research work by Cobeen (2010). Based on *shear wall* performance, similar revisions were made to the deflection Equation B5.4.4-1 for the *diaphragm* systems.

B5.4.5 Beam Diaphragm Tests for Non-Steel Sheathed Assemblies

Consistent with wood-framed construction, for the in-plane diaphragm, the *nominal shear strength [resistance]* is permitted to be determined by a beam test in accordance with ASTM E455 (2011e). The *nominal shear strength* is to be the average of a minimum of three tests in accordance with AISI S100 [CSA S136] Section F1.1(a).

The determination of the *safety factor* and *resistance factor*, when failure occurs in the cold-formed steel member or sheathing-to-steel fasteners, is based on the screw connection statistics from AISI S100 [CSA S136] Chapter F and is consistent with AISI S100 [CSA S136], Section D6.2.1.

The *safety factor* of 2.8 and *resistance factor* of 0.6 are used to be consistent with the wood sheathing failure as prescribed by the wood industry (AFPA, 2008).

The beam test provides diaphragm performance for an essentially rectangular building configuration. The aspect ratio of 4:1 reflects the limit for essentially rectangular buildings as prescribed by AISI S230.

C. INSTALLATION

C2 Material Condition

To ensure structural performance is in compliance with the engineered design, *structural members, connectors, hold-downs* and mechanical fasteners must not be damaged. Damage assessment is not within the purview of this Standard. The *design professional* should be consulted when damage alters the cross-section geometry of a *structural member*, or damages to *connectors, hold-downs* and mechanical fasteners beyond the specified tolerances.

C2.1 Web Holes

AISI S100 [CSA S136] stipulates design requirements for members with standard *web* holes. In the field, these “*web* holes” may also be referred to as “*punchouts*,” “*utility holes*,” “*perforations*” and “*web penetrations*.” In *structural members*, *web* holes are typically 1.5 in. (38 mm) wide × 4 in. (102 mm) long and are located on the center line of the *web*. The *web* holes are generally spaced 24 in. (610 mm) on center.

C2.2 Cutting and Patching

This Standard places restrictions on acceptable methods for cutting of framing members so that cut edges are not excessively rough or uneven and protective metallic coatings are not damaged in areas away from cut edges. It is noted that shearing includes a variety of mechanical methods including, but not limited to, the use of hydraulic shears and hole punches during manufacturing; and portable hydraulic shears, hand-held electric shears, aviation snips, and hole punches during fabrication and installation.

Coping, cutting or notching of *flanges* and *edge stiffeners* is not permitted for *structural members* without an *approved* design. For guidance on design for coped members in *trusses*, refer to Section E4.6.2.

C2.3 Splicing

Structural members may be spliced; however, splicing of *studs* and *joists* is not a common practice and is not recommended. If a *structural member* requires splicing, the splice *connection* must be installed in accordance with an *approved* design.

C3 Structural Framing

C3.1 Foundation

An uneven foundation may cause problems. The specified ¼ in. (6.4 mm) gap has been deemed acceptable industry practice.

C3.2 Ground Contact

To minimize the potential for corrosion, care must be taken to avoid direct contact between the *cold-formed steel* framing and the ground. In addition to direct contact, it is important to minimize the potential for corrosion resulting from ambient moisture. The *applicable building code* is cited as the authoritative document that will provide guidance concerning minimum separation distances from the ground to the framing member, installation requirements for moisture barriers, and the necessary ventilation of the space.

C3.3 Floors

To avoid premature failure at a support and to achieve in-line framing, full bearing of the *joist* on its supporting wall is necessary. The intent of specifying that the *track* and *joist webs* are not to be in direct contact with each other is to prevent floors from creating an unwanted noise (e.g. squeaks).

C3.4 Walls

C3.4.1 Straightness, Plumbness and Levelness

Wall *studs* must be installed plumb to avoid the potential for secondary bending moments in the member. In 2015, a reference to tolerances in ASTM C1007 (ASTM, 2011d) for plumbness and levelness was added.

C3.4.3 Stud-to-Track Connection

The *stud* must be nested and properly seated into the top and bottom *track* to provide for adequate transfer of forces and minimize axial deflections. Each *flange* of the *stud* should also be attached to the *tracks* to brace the top and bottom of the *stud* against weak axis and torsional displacements.

The maximum end gap specified by this Standard is based on traditional industry practice. The gap specified in Section C3.4.3(a) is only for axial load bearing walls, which is defined in Section 202 of the IBC (ICC, 2012) as any metal or wood stud wall that supports more than 100 pounds per linear foot (1459 N/m) of vertical load in addition to its own weight.

Axial loads in a wall *stud* in excess of the capacity of the screw *connection* between the *stud* and its seating tracks will be transferred between the *stud* and *track* in bearing. In this situation, if a *stud* is not properly seated, relative movement between the *stud* and the *track* may occur, which reduces or closes any gap between the end of the *stud* and the *track*.

To determine the influence of this relative movement between the *stud* and the *track* on the serviceability of sheathed wall assemblies, a testing program was conducted at the University of Missouri-Rolla (Findlay, 2005). The UMR test program only considered the *stud* and the *track* having the same thickness. For thinner *stud* and *track* materials (0.054 inches (1.37 mm) or less), testing showed that relative movement between the *stud* and the *track* was accommodated through a combination of *track* deformation and screw tilting. In these cases the *connection* remained intact and was capable of resisting uplift forces and preventing *stud* weak axis and torsional displacement. For thicker materials (greater than 0.054 inches), testing showed that the relative movement between the *stud* and the *track* could result in shear failure of the screws. In these cases, testing indicated a smaller end gap tolerance (e.g., 1/16 inch (1.59 mm)) would be desirable to limit relative movement and potential screw failure.

In addition to a smaller specified end gap to avoid potential screw failure in *track* thicker than 0.054 inches (1.37 mm), a smaller specified gap may also be desirable for multi-story structures where the accumulation of gap closures may become significant. Special considerations may also be desirable for heavily loaded cold-formed steel structures and conditions susceptible to deflections.

One method to help achieve adequate end bearing and minimize undesirable relative movement between the *stud* and the *track* is to specify a smaller 1/16 in. (1.59 mm) gap. This is a relatively simple criterion to verify. However, not exceeding the 1/16 in.

(1.59 mm) gap is on occasion difficult to achieve, particularly with 0.097 in. (2.46 mm) or thicker *track*.

Another method to achieve adequate end bearing is to pre-compress the *stud* inside the *track*. This is often accomplished when panelizing the *stud* walls and pre-compressing the wall panel before connecting the *track* to the *studs*. Wall panelization and pre-compression, particularly for multi-story cold-formed steel construction, has become a common practice in several regions of North America. With pre-compression, it can be relatively assured that the *stud* will be seated in the *track*, regardless of the gap after pre-compression. At present, there are no specific guidelines for the amount of pre-compressive force required to assure proper seating. Industry practice has been to compress the wall panel until the *studs* visually seat inside the radius of the *track* and before the *studs* begin to buckle. Jacking force will vary depending upon the *stud* size and wall panel height, but is typically several hundred pounds minimum per *stud*. Guidelines for verification of proper pre-compression are nonexistent, but typically pre-compression will result in gaps of 1/16 in. (1.59 mm) or less for the majority of *stud-to-track connections*, with no gap exceeding 1/8 inch.

A third method to help ensure adequate end bearing is to oversize the *web* depth of the *track* to minimize any gap. *Track* oversized 1/16 to 1/8 in. (1.59 mm to 3.18 mm) will usually have a flat *web* between the *track* radii that is greater than the depth of the *stud*, enabling the *stud* to bear directly on the *web* instead of the *track* radii. This method will often be desirable when bearing walls are stick-framed instead of panelized and pre-compressed. One disadvantage is the oversized *track* may make a flat wall finish more difficult.

For all thickness of materials, testing has shown that the gap between the sheathing and the floor should be equal to or greater than the gap between the *stud* and the *track*.

C3.5 Roofs and Ceilings

Proper installation and alignment of *roof joists* and *ceiling joists* is necessary to ensure the proper load transfer from the *rafter/ceiling joist connection* to the wall framing. To avoid premature failure at a support and to achieve in-line framing, full bearing of the *joist* on its supporting wall framing member or a minimum 1-1/2 inch (38 mm) end bearing is necessary.

C3.6 Lateral Force-Resisting Systems

Proper installation, consistent with the construction of the tabulated systems that were tested, is deemed necessary for the performance of the system. Flat *strap* used as *blocking* to transfer shear forces between sheathing panels is permitted, but is not required to be attached to framing members. For *wood structural panel*, gypsum board and *fiberboard* sheathing, screws must be installed through the sheathing to the *blocking*. Sheathing screws should be driven to the proper depth appropriate for the head style used. Bugle, wafer and flat head screws should be driven flush with the surface of the sheathing; pan head, round head, and hex-washer head screws should be driven with the bottom of the head flush with the sheathing. See Commentary Section B5.2.2.1 for more discussion on overdriving sheathing screws.

C4 Connections

C4.1 Screw Connections

C4.1.2 Installation

Screw length must be adequate to ensure that screw fasteners extend through the steel *connection* a minimum of three (3) exposed threads, as illustrated in Figure C-C4.1.2-1.

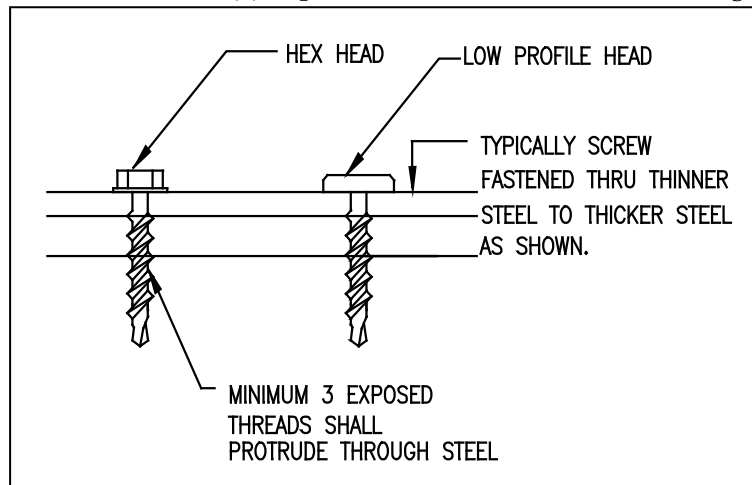

Figure C-C4.1.2-1 Screw Grip Range

C4.1.3 Stripped Screws

It is unreasonable to expect that there will be no stripped screws in a *connection*. Research at the University of Missouri-Rolla (Sokol et al., 1999) has shown that the structural performance of a single-shear screw *connection* is not compromised if screws in the *connection* have been inadvertently stripped during installation. This research serves as the basis for the requirements of the Standard.

C4.2 Welded Connections

To maintain acceptable durability of a welded *connection*, the weld area must be treated with a corrosion-resistant coating, such as a zinc-rich paint.

C5 Miscellaneous

C5.1 Utilities

C5.1.1 Holes

The design should include references to pre-punch hole sizes or limitations to accommodate electrical, telecommunication, plumbing and mechanical systems. Field-cut holes are generally discouraged, but are not uncommon. Field-cut holes, if necessary, are required to comply with Section C2.1. There are several methods whereby holes can be cut in the field, such as a hole-punch, hole saws, and plasma cutters.

Holes that penetrate an assembly containing steel framing that has a fire resistance rating will need to be designed with through-penetration firestop systems. The acceptance of this fire resistance design is based on the *applicable building code*.

C5.1.2 Plumbing

Direct contact with copper piping should be avoided in order to prevent galvanic action from occurring. Methods for preventing the contact from occurring may be through the use of nonconductive and noncorrosive grommets at *web* penetrations or through the use of nonmetallic brackets (a.k.a. isolators) fastened to hold the dissimilar metal building products (e.g. piping) away from the steel framing. Plastic pipe does not require protection if it is in contact with the *cold-formed steel* framing member, but consideration should be made for the installation of nonmetallic brackets to hold the pipe away from the hole in the steel in order to prevent noise and prevent the steel from cutting into the pipe.

C5.1.3 Electrical

Nonmetallic sheathed wiring must be separated from the *cold-formed steel* framing member in order to comply with the *National Electrical Code* (NFPA, 2011). Contained within the *National Electrical Code* is a provision that requires nonmetallic sheathed cable to “be protected by bushings or grommets securely fastened in the opening prior to the installation of the cable.” Cable following the length of a framing member will need to be secured (e.g., supported) at set lengths; for this purpose, small holes in the *web* may be beneficial for the attachment of tie-downs (e.g. nylon cable ties, nylon zipper ties, etc.). When installing wiring or cables within a framing member (e.g., through or parallel to member), the intent of the *National Electrical Code* further requires that the wiring or cables be located 1-1/4 inches (32 mm) from the edge of the framing member. When 2-1/2-inch (64-mm)-wide wall *studs* are used, the restrictions concerning edge clearance apply.

C5.2 Insulation

The cavity insulation must be installed such that the width of the insulation extends from the face of the *web* of one framing member to the face of the *web* of the next framing member. In the case of *cold-formed steel* framing, designs should specify “full-width” insulation in order to differentiate the insulation that is normally supplied (nominal width).

To enhance the thermal performance of *cold-formed steel* framed construction, board insulation (such as continuous insulation or insulating sheathing) may be used in conjunction with cavity insulation. Guidance on the use of board and batt insulation is given in *Thermal Design and Code Compliance for Cold-Formed Steel Walls* (SFA, 2008). Designs should also take into consideration the effects of moisture when assessing the application of both cavity and continuous insulation, in this case dew point. The *ASHRAE Handbook of Fundamentals* contains information useful for determining dew point (ASHRAE, 2009).

D. QUALITY CONTROL AND QUALITY ASSURANCE

D1 General

D1.1 Scope and Limits of Applicability

Chapter D provides minimum requirements for *quality control* and *quality assurance* for material control and installation for *cold-formed steel light-frame construction*. Minimum observation and *inspection* tasks deemed necessary to ensure quality *cold-formed steel light-frame construction* are specified.

Chapter D does not apply to *cold-formed steel nonstructural members*. Chapter D does not apply to the manufacture of *cold-formed steel structural members, connectors or hold-downs* other than material control, nor to manufacture of mechanical fasteners or welding consumables. Chapter D does not address *quality control* or *quality assurance* for other materials and methods of construction.

In Chapter D, material control refers to the general oversight of the materials by the *component manufacturer* and *installer* and involves procedures for storage, release and movement of materials. Throughout the manufacturing and construction processes, including the associated *inspections*, materials are identified and protected from degradation. Additionally, nonconforming items are identified and segregated as needed.

The Chapter D requirements are patterned after similar requirements developed by the American Institute of Steel Construction for structural steel and the Steel Deck Institute for steel deck.

Chapter D defines a comprehensive system of *quality control* requirements on the part of the *component manufacturer* and *installer* and similar requirements for *quality assurance* on the part of the project representatives of the *owner* when such is deemed necessary to complement the *contractor's quality control* function. These requirements exemplify recognized principles of developing involvement of all levels of management and the workforce in the *quality control* process as the most effective method of achieving quality in the constructed product. Chapter D supplements these *quality control* requirements with *quality assurance* responsibilities as are deemed suitable for a specific task.

AISI S202, *Code of Standard Practice for Cold-Formed Steel Structural Framing* (AISI, 2011), indicates that the *component manufacturer* or *installer* is to implement a *quality control* system as part of their normal operations. The *registered design professional* should evaluate what is already a part of the *component manufacturer's* or *installer's quality control* system in determining the *quality assurance* needs for each project. Where the *component manufacturer's* or *installer's quality control* system is considered adequate for the project, including compliance with any specific project needs, the "special inspection" or *quality assurance* plan may be modified to reflect this. Similarly, where additional needs are identified, supplementary requirements should be specified.

The terminology adopted for use in Chapter D is intended to provide a clear distinction of *component manufacturer* and *installer* requirements and the requirements of others. The definitions of *quality control* and *quality assurance* used here are consistent with usage in related industries. It is recognized that these definitions are not the only definitions in use.

For the purposes of this Standard, *quality control* includes those tasks performed by the *component manufacturer* and *installer* that have an effect on quality or are performed to measure or confirm quality. *Quality assurance* tasks performed by organizations other than

the *component manufacturer* and *installer* are intended to provide a level of assurance that the product meets the project requirements. The terms *quality control* and *quality assurance* are used throughout Chapter D to describe *inspection* tasks required to be performed by the *component manufacturer* and *installer* and representatives of the *owner*, respectively. The *quality assurance* tasks are *inspections* often performed when required by the *applicable building code* or *authority having jurisdiction*, and designated as “special inspections,” or as otherwise required by the project *owner* or *registered design professional*.

D1.2 Responsibilities

The requirements in Chapter D are considered adequate and effective for most *cold-formed steel light-frame construction*.

Where the *applicable building code* and *authority having jurisdiction* require the use of a *quality assurance* program, Chapter D outlines the minimum requirements deemed effective to provide satisfactory results in *cold-formed steel light-frame construction*. There may be cases where supplemental *inspections* are advisable. Additionally, where the *contractor’s quality control program* has demonstrated the capability to perform some tasks that this plan has assigned to *quality assurance*, modification of the plan could be considered.

D2 Quality Control Programs

Many quality requirements are common from project to project. Many of the processes used to produce *cold-formed steel light-frame construction* have an effect on quality and are fundamental and integral to the *component manufacturer’s* or *installer’s* success. Consistency in imposing quality requirements between projects facilitates more efficient procedures for both. The *construction documents* referred to in Chapter D are, of necessity, the versions of the *plans*, *specifications*, and *approved shop drawings* and *approved installation erection drawings* that have been released for construction, as defined in AISI S202. When responses to requests for information and change orders exist that modify the *construction documents*, these are also part of the *construction documents*. When a building information model is used on the project, it is also a part of the *construction documents*.

Elements of a *quality control* program can include a variety of documentation such as policies, internal qualification requirements, and methods of tracking production progress. Any procedure that is not apparent subsequent to the performance of the work should be considered important enough to be part of the written procedures. Any documents and procedures made available to the *quality assurance inspector* should be considered proprietary and not distributed inappropriately.

The *inspection* documentation should include the following information:

- (1) The product inspected
- (2) The process that was conducted
- (3) The name of the inspector and the time period within which the *inspection* was conducted
- (4) Non-conformances and corrections implemented

Records can include marks on pieces, notes on drawings, process paperwork, or electronic files. A record showing adherence to a sampling plan for pre-welding compliance during a given time period may be sufficient for pre-welding observation *inspection*.

The level of detail recorded should result in confidence that the product is in compliance with the requirements.

D3 Quality Control Documents

D3.1 Documents to be Submitted

The documents listed must be submitted so that the *registered design professional* can evaluate that the items prepared by the *component manufacturer* or *installer* meet the *registered design professional's* design intent. This is usually done through the submittal of *shop drawings* and *installation drawings*. In many cases digital building models are produced in order to develop *shop drawings* and *installation drawings*. In lieu of submitting *shop drawings* and *installation drawings*, the digital building model can be submitted and reviewed by the *registered design professional* for compliance with the design intent. For additional information concerning this process, refer to the AISC *Code of Standard Practice for Steel Buildings and Bridges* Appendix A, Digital Building Product Models.

The exception in Section D3.1.1.3 limits the additional requirements in Sections D3.1.1.1 and D3.1.1.2 to *lateral force-resisting systems* with relatively high capacities.

D3.2 Available Documents

The documents listed must be made available for review by the *registered design professional*. In some instances, the *registered design professional* may require the submittal of additional documents. Certain items are of a nature that submittal of substantial volumes of documentation is not practical, and therefore it is acceptable to have these documents reviewed at the *component manufacturer's* or *installer's* facility by the *registered design professional* or *quality assurance* agency. Additional commentary on some of the documentation listed in this section is as follows:

- (a) Documents related to *connectors, hold-downs* and mechanical fasteners are required only in cases where *connectors, hold-downs* and mechanical fasteners are being installed.
- (b) Documents related to welding are required only in cases where welding of *cold-formed steel structural members* is being performed.
- (c) Specific welders may not be known until installation begins; therefore, welding personnel performance qualification records may not be made available until immediately before installation begins.
- (d) Because the selection and proper use of welding filler metals is critical to achieving the necessary levels of strength and quality, the availability for review of welding filler metal documentation and welding procedure specifications (WPSs) is required. This allows a thorough review on the part of the *registered design professional*, and allows the *registered design professional* to have outside consultants review these documents, if needed.
- (e) The *component manufacturer* and *installer* maintain written records of welding personnel qualification testing. Such records should contain information regarding date of testing, process, welding procedure specifications, test plate, position, and the results of the testing. In order to verify the six-month limitation on welder qualification, the *component manufacturer* and *installer* should also maintain a record documenting the dates that each welder has used a particular welding process.

D5 Inspection Personnel

D5.1 Quality Control Inspector

The *component manufacturer* or *installer* determines the qualifications, training and experience required for personnel conducting the specified *inspections*. Qualifications should be based on the actual work to be performed and should be incorporated into the *component manufacturer's* or *installer's quality control* program. *Inspection* of welding should be performed by an individual who, by training and/or experience in metals fabrication, *inspection* and testing, is competent to perform *inspection* of the work. Recognized certification programs are a method of demonstrating some qualifications, but they are not the only method nor are they required by Chapter D for *quality control* inspectors.

D5.2 Quality Assurance Inspector

The *quality assurance* agency determines the qualifications, training and experience required for personnel conducting the specified *quality assurance inspections*. This may be based on the actual work to be performed on any particular project. Qualification for the *quality assurance* inspector may include experience, knowledge and physical requirements. These qualification requirements are documented in the *quality assurance* agency's written practice. AWS B5.1 (AWS, 2003) is a resource for qualifications of a welding inspector.

D6 Inspection Tasks

D6.1 General

Chapter D defines two *inspection* levels for required *inspection* tasks and labels them as either "observe" or "perform." This is in contrast to common building code terminology which uses or has used the terms "periodic" or "continuous." However, this is consistent with the AISC and SDI standards that were used as a pattern for this Standard.

The tables in Sections D6.5 through D6.9 list the required *inspection* tasks for *quality control* and *quality assurance*. If *inspections* identify nonconforming material or workmanship, the need for additional *inspections* and rejection of material is to be assessed in accordance with Section D7.

The tables in Sections D6.5 through D6.9 also list the required documentation tasks for *quality assurance*. Documentation tasks for *quality control* are not required by Chapter D, but should be as defined by the applicable *quality control program* of the *component manufacturer* or *installer*.

D6.2 Quality Control Inspection Tasks

Quality control documentation is an internal record for the *component manufacturer* or *installer* to record that the work has been performed and that the work is in accordance with the *shop drawings* or *construction documents*, as applicable. Depending upon the *component manufacturer's* or *installer's quality control program*, the method of documentation may vary.

Model building codes, such as the *International Building Code* (ICC, 2015), often make specific statements about performing *inspections* to *approved construction documents*. AISI S202 requires the transfer of information from the *contract documents* into accurate and complete *shop drawings* and *installation drawings*. Therefore, relevant items in the *plans* and *specifications* that must be followed in component manufacturing and installation should be placed on the *shop drawings* and *installation drawings*, or in typical notes issued for the project. Because of

this provision, *quality control inspection* may be performed using *shop drawings* and *installation drawings*, not the original *plans* and *specifications*.

D6.3 Quality Assurance Inspection Tasks

Model building codes, such as the *International Building Code* (ICC, 2015), make specific statements about performing *inspections* to *approved construction documents*. Accordingly, the *quality assurance inspector* should perform *inspections* using the original *plans* and *specifications*. The *quality assurance inspector* may also use the *shop drawings* and *installation drawings* to assist in the *inspection* process.

D6.4 Coordinated Inspection

Coordination of *inspection* tasks may be needed for *component manufacturers* in remote locations or distant from the project itself, or for *installers* with projects in locations where *inspection* by a local firm or individual may not be feasible or where tasks are redundant. The approval of both the *authority having jurisdiction* and *registered design professional* is required for *quality assurance* to rely upon *quality control*, so there must be a level of assurance provided by the quality activities that are accepted.

D6.5 Material Verification

Compliance of *cold-formed steel structural members* typically includes verification of product identification in accordance with Section A5.5 and shape dimensions and sizes in accordance with an *approved design* or *approved design standard*. The manufacturer of *cold-formed steel structural members* is typically responsible for verification of material in accordance with Section A3, corrosion protection in accordance with Section A4, and *base steel thickness* in accordance with Section A5.1.

The *installer* should consider Section G1.1 of AISI S202 when establishing material control procedures for *cold-formed steel structural members*. *Cold-formed steel structural members* that lack product identification are typically tested to determine conformity.

D6.6 Inspection of Welding

Compliance of welds typically includes verification of weld size, length and location.

D6.7 Inspection of Mechanical Fastening

Compliance of mechanical fasteners typically includes verification of mechanical fastener type, diameter, length, quantity, spacing, edge distance and location.

D6.8 Inspection of Cold-Formed Steel Light-Frame Construction

Compliance of cold-formed steel light-frame construction typically includes verification of component assembly, structural member and connector sizes and locations; bracing, blocking and bearing stiffener sizes and locations; and bearing lengths.

D6.9 Additional Requirements for Lateral Force-Resisting Systems

Compliance of *cold-formed steel lateral force-resisting system* installation typically includes verification of *shear walls*; *diagonal strap bracing* and *gusset plates*; *hold-downs* and anchor bolts; *collectors* (drag struts); and *diaphragms*.

The exception in Section D6.9 limits the additional requirements to *lateral force-resisting systems* with relatively high capacities.

In Table D6.9-2, a welder identification system is a system maintained by the *component manufacturer* or *installer*, as applicable, by which a welder who has welded a joint or member can be identified.

E. TRUSSES

E1 General

E1.1 Scope and Limits of Applicability

Cold-formed steel trusses are planar structural components. Structural performance depends on the *trusses* being installed vertically, in-plane, and at specific spacing, and being properly fabricated and braced. The Standard describes the materials used in a *cold-formed steel truss*, as well as design, fabrication, and bracing procedures for *truss* members.

This Standard is intended to serve as a supplement to AISI S100 [CSA S136], (AISI, 2012a; CSA, 2012). The provisions provided in Chapter E are also intended to be used in conjunction with the other chapters of the Standard.

E2 Truss Responsibilities

The Standard adopts Section I1 of AISI S202 (AISI, 2011a) for the responsibilities of the individuals and organizations involved in the design, fabrication and installation of *cold-formed steel trusses*. Alternate provisions as agreed upon by the involved parties are permitted.

E3 Loading

The Standard does not establish the appropriate loading requirements for which a *truss* should be designed. In most cases, these loads are adequately covered by the *applicable building code* or standard.

E4 Truss Design

The provisions contained in this section of the Standard address the various design aspects related to *truss* strength [*resistance*]. The strength [*resistance*] determinations required by the Standard are in accordance with either the *Allowable Strength Design (ASD)*, *Load and Resistance Factor Design (LRFD)* or *Limit States Design (LSD)* methods given by AISI S100 [CSA S136], (AISI, 2012; CSA, 2012), except where additional research studies have indicated an alternative approach is warranted.

E4.3 Analysis

The structural analysis requirements contained in the Standard are based on available information pertaining to the behavior of *cold-formed steel C-shaped* section *truss* assemblies (Harper, 1995; LaBoube and Yu, 1998). These requirements do not preclude the use of more rigorous analysis or design assumptions as determined by rational analysis or testing.

E4.4 Member Design

E4.4.1 Properties of Sections

AISI S100 [CSA S136] has been shown to be highly reliable for determining the design cross-section properties of *C-shapes* and other simple geometries. For more complex shapes, such as those utilizing longitudinal stiffeners, AISI S100 [CSA S136] Direct Strength Method design provisions may be used to estimate the load-carrying capacity. Tests in accordance with Section F1 of AISI S100 [CSA S136] can also be used.

E4.4.2 Compression Chord Members

When subjected to gravity load, the compression *chord member* may experience the combined effects of bending and axial compression. The design for combined load effects is governed by Section C5.2 of AISI S100 [CSA S136].

Engineering design specifications recognize the need for using rational analysis or test to define an effective length factor. The Standard permits the use of either rational analysis or testing.

Based on research on *C-shaped* section *trusses* conducted at the University of Missouri-Rolla (UMR) (Harper, 1995; Ibrahim, 1998), it was determined that the unbraced lengths, L_x and L_t , may be taken as equal to the distance between the panel points. It was also discovered that where structural sheathing is attached to the *chord member* and where the compression *chord member* is continuous over at least one intermediate panel point, and is continuous from the *heel* to the *pitch break*, *heel to heel* (in the case of a parallel chord *truss*), or breakpoint of a *truss*, L_y may be taken as the distance between sheathing connectors. Engineering judgment indicates that where sheathing is not attached to the top *chord member*, L_y may be taken as the distance between panel points.

In the *cold-formed steel truss* industry, the sheathing is used as a structural component and the *connection* spacing of the sheathing to the *cold-formed steel* member is a design consideration. Therefore, sheathing connector spacing is indeed a structural requirement, and that is why the spacing of the connector is used when designing the *truss* chords for compression when there is structural sheathing applied.

The UMR research also determined that for a structurally sheathed *C-shaped* section *truss* where the compression *chord member* is continuous over at least one intermediate panel point, and is continuous from the *heel* to the *pitch break*, or breakpoint of a *truss*, K_x , K_y , and K_t may be taken as 0.75. For other compression *chord members*, based on engineering judgment, K_x , K_y , and K_t should be taken as unity.

An alternative design assumption for *chord members* in compression, based on engineering practice and judgment, is to assume that the effective length be taken as the distance between two adjacent points of contraflexure. In such case, the effective length factor and C_m should be taken as unity.

The required effective length factors and unbraced lengths given in the Standard for hat-shapes are based on engineering judgment. The *Z-shape* requirements are based on proprietary testing.

Consistent with AISI S100 [CSA S136], the end moment coefficient, C_m , should be taken as 0.85, unless a more rigorous analysis is performed to justify another value.

Requirements in the Standard for the evaluation of the bending strength [resistance] are based on engineering judgment.

Ibrahim et al. (1998)- determined that when a *C-shaped* section compression *chord member* is subject to concentrated load at a panel point, the interaction of axial compression, bending and *web* crippling must be considered. The researchers proposed the following ASD interaction equation:

$$\frac{P}{P_{no}} + \frac{M}{M_{nxo}} + \frac{R}{R_n} \leq \frac{1.49}{\Omega} \quad (\text{Eq. C-E4.4.2-1})$$

where

P = Compression axial load

- M = Bending moment
 R = Concentrated load
 P_{no} = Nominal axial strength [resistance] computed at $f = F_y$
 M_{nxo} = Nominal flexural strength [resistance] computed at $f = F_y$
 R_n = Nominal interior one-flange web crippling strength [resistance]
 Ω = Safety factor
 = 1.95

The values of P and M are to be determined by structural analysis for the panel point in question, where R is the applied concentrated load at the panel point. The *nominal strengths* [resistances] are to be computed using AISI S100 [CSA S136]. Based on a statistical analysis consistent with load and resistance factor design, the *safety factor* was determined. The Standard also includes a similar equation applicable to the LRFD and LSD methods.

E4.4.3 Tension Chord Members

The design requirements prescribed by the Standard for tension *chord members* are based on experience and engineering judgment.

E4.4.4 Compression Web Members

The behavior of a compression *web member* is a function of the *connection* of the *web member* to the *chord member*. For example, a common *connection* detail of *C-shaped chord* and *web members* is to attach the respective members back-to-back through their *webs*. Such a *connection* detail creates an eccentric loading condition in the *web member*. When an axial load is applied to a *truss web member* in this type of *truss* construction, this eccentric loading condition will produce a bending moment in the member that is acting out-of-plane to the *truss*. This bending moment needs to be analyzed using Section E4.4.4 of this Standard. In addition to the check in this Standard, a compression *web member* is to be analyzed with the axial load alone using Section C4 of AISI S100 [CSA S136].

Researchers at the University of Missouri-Rolla (Rieman, 1996; Ibrahim et al., 1998) determined that for a *C-shaped* compression *web member* that is attached through its *web* element, the interaction of axial compression and out-of-plane bending may be determined by the following *ASD* interaction equation:

$$\frac{\Omega_c R P}{P_n} + \frac{\Omega_b C_{my} R P e}{M_{ny} \alpha_y} \leq 1.0 \quad (\text{C-E4.4.4-1})$$

where

$$R = -\left(\frac{L/r}{173}\right)^2 + \frac{L/r}{88} - 0.22 \geq 0.6 \quad (\text{C-E4.4.4-2})$$

L = Unbraced length of the compression *web member*

r = Radius of gyration of the full section about the minor axis

P_n = Nominal axial strength [resistance] based on Section C4.1 of AISI S100 [CSA S136].

Only flexural buckling need be considered.

e = Eccentricity of compression force with respect to the centroid of the full section of the *web member*

Other variables are defined in Section C5.2.1 of AISI S100 [CSA S136].

The parameter, R , is an experimentally determined reduction imposed on the axial load. The equation is a fit to the average test data, which is a common practice in *cold-formed steel* research. To recognize the lower limit on the tested L/r ratio, the Standard

stipulates $R \geq 0.6$. The intent of R is to recognize the increased significance of the bending effect, compared to the axial effect for longer length *web members*. Unique to the application of the interaction equation is the determination of the *nominal axial strength [resistance]* based on flexural buckling alone. Research showed that the minor axis bending, which resulted from the eccentrically applied axial load, created a member deflection that enabled only flexural buckling. Thus, the behavior of the *web member* was determined predominately by bending resulting from the eccentric load. The parameters P , Ω_b , Ω_c , C_{my} , M_{ny} and α_y are defined in accordance with Section C5.2.1 of AISI S100 [CSA S136]. The Standard also includes a similar equation applicable to the LRFD and LSD methods.

For compression *web member* cross-sections other than a *C-shape* attached through its *web* element, which has symmetry of loading, the axial compression load may be taken as acting through the centroid of the section.

When computing the *available strength [factored resistance]*, the effective lengths, $K_x L_x$, $K_y L_y$ and $K_t L_t$, may be taken as the distance between the centers of the member's end *connection* patterns. This assumption is consistent with the analysis approach used by UMR researchers (Rieman, 1996; Ibrahim et al., 1998).

E4.4.5 Tension Web Members

Tension *web members* may experience a reduction in load-carrying capacity when subjected to combined axial load and bending. For *C-shaped* sections, this may be attributed to the dominant behavior being that of bending resulting from the eccentric load. However, testing has not documented that the combined loading compromises the integrity of the tension member. Therefore, for a tension *web member* connected to the *web* element of a *chord member*, or connected to a *gusset plate*, the Standard permits the axial tension load to be taken as acting through the centroid of the *web member's* cross-section.

E4.4.6 Eccentricity in Joints

The Standard does not specify the use of a multiple or single node structural analysis model to account for the effects of eccentricity in joints. The *truss* stiffness will differ based on whether a multiple or single node analysis is performed. When a multiple node analysis is used, a node should be placed at each *web member* location where the center line of the *web member* meets the center line of the *chord member*. When performing a single node analysis, additional design considerations may be necessary. For example, eccentricity created by the spatial relationship of the *web members* and the *chord member* at a joint may generate additional moments, shears, and/or axial forces. Such moments and forces may be directly reflected in a multiple node analysis model. Thus, when using a single node analysis model, a secondary analysis and design check of the joint, or a load test may be required to justify the design.

The Standard defines a *web member* lap length as 75% of the *chord member* depth. This minimum lap length is assumed, based on engineering judgment, to serve as a *web* shear stiffener for the *chord member*. The *chord member* segment between the assumed stiffeners is to be investigated for combined bending and shear, where a stiffened shear panel is assumed, in accordance with Equation C3.3.1-2 of AISI S100 [CSA S136]. For *truss* configurations having the *web member* lap length less than 75% of the *chord member's* depth, the *chord member* is to be investigated for combined bending and shear in accordance with Equation C3.3.1-1 of AISI S100 [CSA S136]. Refer to Figures C-E4.4.6 (a) and C-E4.4.6 (b) for a pictorial definition of the term "*web member lap length*" for two configurations of a *truss*

web member and *truss chord member connection*. Rational design assumptions for this “*web member lap length*” must be used when other *connection* geometries are encountered.

Along the length of the *chord member*, at the mid-point between the intersecting *web members*, shear is to be evaluated by Section C3.2 of AISI S100 [CSA S136]. The shear buckling coefficient is taken to be consistent with the assumed shear panel condition at the segments’ ends as defined by Section C3.2 of AISI S100 [CSA S136].

Based on experience, where screws are used as the connector, a minimum of four screws should be used in a *web member* to *chord member connection* and the screws should be equally distributed in their group.

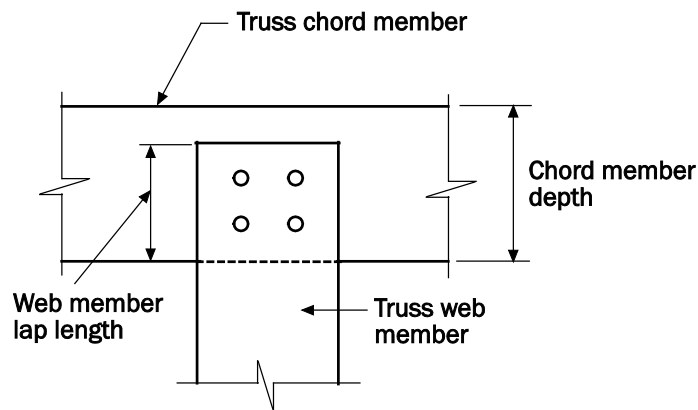

(a) Web Member Lap Length for Flat Truss Chord

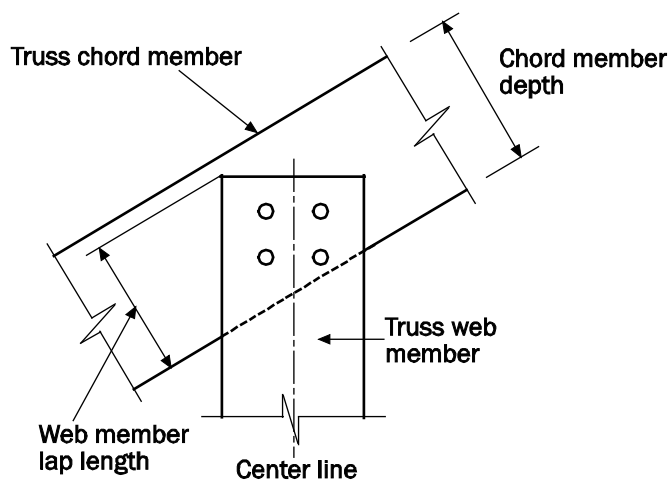

(b) Web Member Lap Length for Sloped Truss Chord

Figure C-E4.4.6 Web Member Lap Lengths

E4.5 Gusset Plate Design

To establish a design methodology for thin *gusset plate connections* in compression, a testing program consisting of 49 specimens was conducted at the University of Missouri-Rolla (Lutz, 2004). Two separate models were developed to predict the capacity of the plates. Both plate buckling and column buckling models were studied. Although both models are sufficient for calculating the strength [*resistance*] of the *gusset plates*, it was recommended that

the plate-buckling model be used in design. The plate-buckling model, assuming $f=F_y$, $k=4$ and $w=W_{\min}$, provided a better correlation to the test data. A limited number of tests were performed to determine the strength gain in *gusset plates* with edge stiffeners. The results of tests in which both edges of the *gusset plate* parallel to the applied load had edge stiffeners showed an approximate strength increase of 25% for the plates.

The *gusset plate* design provisions in the Standard require that W_{\min} be taken as the lesser of the actual *gusset plate* width or the Whitmore section, which defines a theoretically effective cross-section based on a spread-out angle of 30° along both sides of the *connection*, beginning at the first row of fasteners in the *connection*. The first row of fasteners is defined as the row of fasteners that is the furthest away from the section of *gusset plate* being considered. Figure C-E4.5-1 illustrates how W_{\min} can be determined for a typical fastener pattern connecting a *truss chord member* to a *gusset plate* at a typical *pitch break connection* at the ridge of a roof *truss*. Determining W_{\min} for other conditions would be analogous.

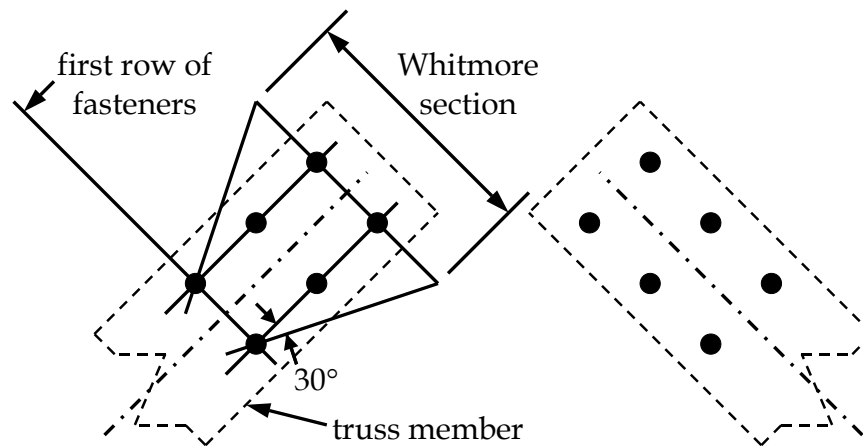

Figure C-E4.5-1 Whitmore Plate Width

The *gusset plate* design provisions in the Standard require that L_{eff} be taken as the average length between the last rows of fasteners of adjacent *truss* members. Figure C-E4.5-2 illustrates how L_{eff} can be determined for a typical *pitch break connection* at the ridge of a roof *truss*. Determining L_{eff} for other conditions would be analogous.

For *gusset plates* in tension, reference is made to the requirements of AISI S100 [CSA S136]. These requirements include checks on the gross and net areas of the *gusset plate*, shear lag and group or tear-out of fasteners. Engineering judgment is required to determine the portion of the *gusset plate* to be included in the gross and net area checks.

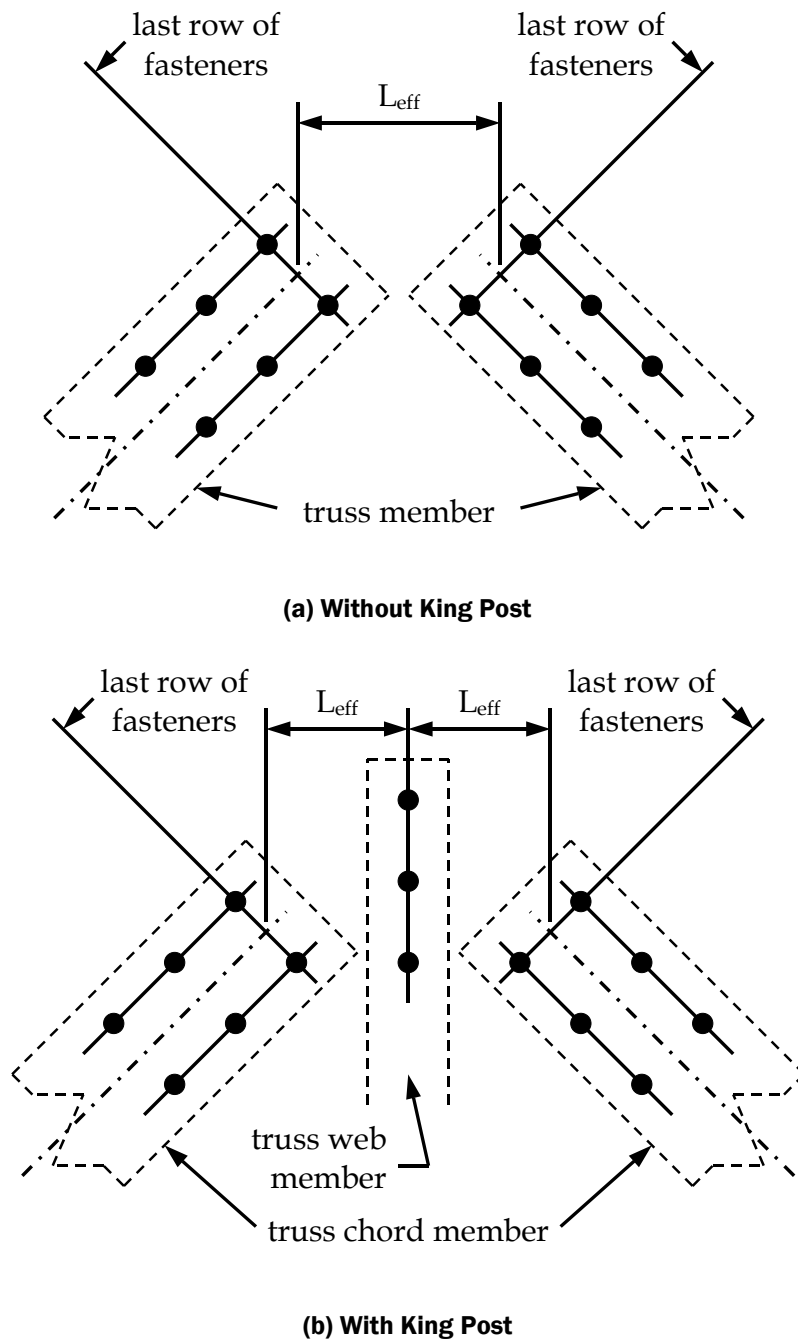

Figure C-E4.5-2 Effective Length for Typical Pitch Break Connection

E4.6 Connection Design

E4.6.1 Fastening Methods

Although the common fastening system used by the industry is the self-drilling screw, the Standard permits the use of bolts, welds, rivets, clinches, and other technologies as *approved* by the *truss designer*. Screw, bolt, and weld *connections* are to be designed in accordance with AISI S100 [CSA S136]. If other fastener types, such as rivets, clinches, rosettes, adhesives, etc., are to be used in the fabrication of the *truss*, the design values are to be determined by tests, and the *available strength* [factored resistance] determined in

accordance with Section F1 of AISI S100 [CSA S136].

For the design of connecting elements, such as plates, *gusset plates*, and brackets, reference is made to AISI S100 [CSA S136], which in turn makes reference to Section J4 of AISC 360 (AISC, 2010).

E4.6.2 Coped Connections for C-Shaped Sections

The design engineer should give special attention to the *heel* and *pitch break connections* of the *truss* to ensure structural integrity of the *truss*.

At a *pitch break*, coped members may be reinforced to prevent *web* buckling of the *chord member*. Attachment of a *track* section of the same thickness as the *chord member*, thus creating a box section, and having a length equal to the depth of the *chord member* has been shown to provide adequate reinforcement (Ibrahim, 1998). Lateral *bracing* is also important to stabilize the *pitch break* from overall buckling. At the *heel*, a *bearing stiffener* may be needed to preclude *web* crippling (Koka, 1997).

At a *heel connection*, UMR research (Koka, 1997) determined that coping reduces both the shear buckling and *web* crippling strength [*resistance*] of the coped bottom *chord member*. The UMR research proposed that where a coped *flange* had a *bearing stiffener* with a minimum moment of inertia (I_{\min}) of 0.161 in.⁴ (67,000 mm⁴), the shear strength [*resistance*] could be calculated in accordance with AISI S100 [CSA S136] Section C3.2, but required a reduction as defined by the following factor, R:

$$R = 0.976 + \frac{0.556c}{h} - \frac{0.532d_c}{h} \leq 1.0 \quad (\text{C-E4.6.2-1})$$

The cited limits in the Standard reflect the scope of the experimental study and apply only to *connections* where the bottom *chord member* is coped.

Where a *bearing stiffener* not having the minimum moment of inertia is used, *web* crippling controlled the *heel connection* strength [*resistance*] (Koka, 1997). Therefore, the Standard requires that the computed end one-*flange* loading *web* crippling strength [*resistance*] at the *heel*, as determined by AISI S100 [CSA S136] Section C3.4 be reduced by the following factor:

$$R = 1.036 + \frac{0.668c}{h} - \frac{0.0505d_c}{h} \leq 1.0 \quad (\text{C-E4.6.2-2})$$

The cited limits in the Standard reflect the scope of the experimental study.

Where c = length of cope and d_c = depth of cope as illustrated in Figure C-E4.6.2-1. I_{\min} of the stiffener is computed with respect to an axis parallel to the *web* of the bottom *chord member*.

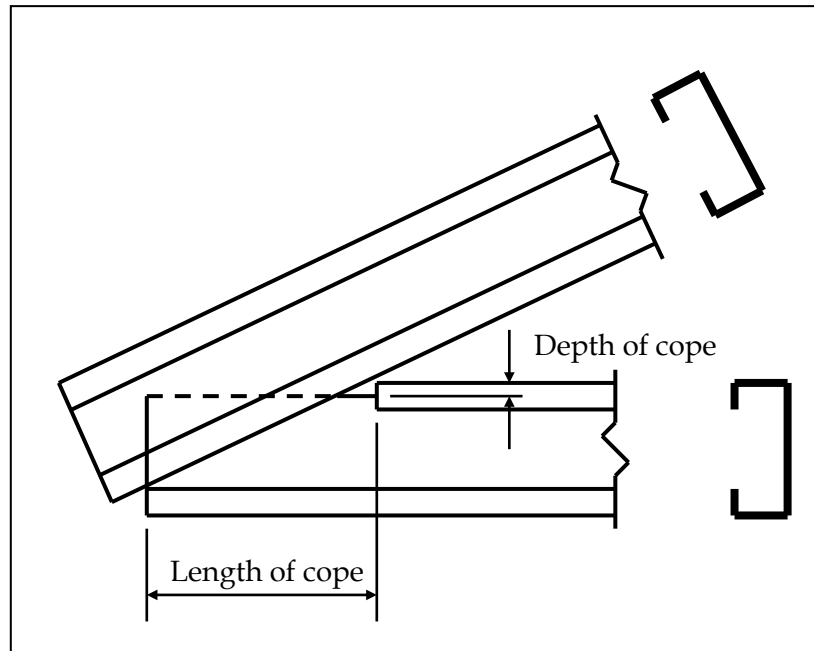

Figure C-E4.6.2-1 Definition of Truss Coping Dimensions

E4.7 Serviceability

Serviceability limits are to be chosen based on the intended function of the structure, and should be evaluated based on realistic loads and load combinations as determined by the *building designer*. Because serviceability limits depend on the function of the structure and the perception of the occupant, it is not possible to specify general limits in the Standard. As a guide to the designer, the maximum allowable deflection of the *chord member* of a *truss* resulting from gravity load, excluding dead load, may be taken as the following:

- (a) Span/360 for plaster ceilings
- (b) Span/240 for flexible type ceilings
- (c) Span/180 for no finished ceiling
- (d) Span/480 for floor systems

Although the use of a deflection limit has been used to preclude vibration problems in the past, some floor systems may require explicit consideration of the dynamic characteristics of the floor system.

Truss serviceability is evaluated at *nominal [specified]* load. When computing *truss* deflections, the Standard permits the use of the full cross-sectional area of the *truss* members. The use of full areas is warranted because a *truss* system is a highly indeterminate structural system, and local buckling of an individual member does not appreciably affect the stiffness of the *truss* at design load.

E5 Quality Criteria for Steel Trusses

The practices defined herein have been adopted by the Standard as commonly accepted practice. In the absence of other instructions in the contract documents, the provisions of Chapter E4 are the quality standard for the manufacturing processes of steel *trusses* to be used in conjunction with an in-plant quality assurance procedure and a *truss* design.

E6 Truss Installation

Cold-formed steel trusses are planar structural components. The structural performance depends on the *trusses* being installed vertically, in-plane, at specified spacing, and being properly braced. The installer is responsible for receipt, storage, erection, installation, field assembly, and *bracing*. The practices defined herein have been adopted by the Standard as commonly accepted practice.

A maximum bottom chord permanent lateral restraint and brace spacing of 10 feet is suggested, based on field experience and limited testing.

E6.1.1 Straightness

The *truss* installation tolerances defined in Section E6.1.1 have been used for many years in the prefabricated *truss* industries of both *cold-formed steel* and wood with good success. The tolerances listed in this section are *truss* assembly tolerances and not individual member tolerances. Member tolerances are outlined in the Standard. *Cold-formed steel trusses* are typically used with structural sheathing applied to the top chord. This sheathing is designed to support lateral loads and act as a diaphragm. This diaphragm system behavior for *trusses* with the structural sheathing is what also enables the adoption of a seemingly more liberal out-of-straightness.

E6.1.2 Plumbness

The *truss* installation tolerances defined in Section E6.1.2 have been used for many years in the prefabricated *truss* industries of both *cold-formed steel* and wood *trusses*.

E7 Test-Based Design

Design calculations require the application of *approved* materials and cross-section properties. When calculations are used to define the structural performance of a *truss* assembly, the structural performance may be verified by full-scale test. However, when the structural performance cannot be determined by calculation, the structural performance must be determined by test. Appendix 2 of this Standard provides guidance for both component and full-scale load tests.

F. TESTING

In 2015, Chapter F was created to allow reference to applicable AISI S900-series test standards.

F1 General

Section F1 lists all the AISI S900-series test standards that are deemed to be generally applicable to *cold-formed steel* structural framing applications.

F2 Truss Components and Assemblies

In 2015, methods for testing truss components and assemblies, formerly in AISI S214 Chapter G, were moved to Appendix 2.

APPENDIX 1, CONTINUOUSLY BRACED DESIGN FOR DISTORTIONAL BUCKLING RESISTANCE

Calculation of the nominal distortional buckling strength in flexure and in compression in accordance with AISI S100 [CSA S136] may utilize the beneficial system effect of sheathing fastened to the compression *flange(s)* of *floor joists*, *ceiling joists*, and *roof rafters* through the calculation of the rotational stiffness provided to the member, k_{ϕ} . It is also permissible, and indeed conservative, to ignore this beneficial restraint and assume $k_{\phi}=0$.

Testing was conducted to determine the provided rotational restraint in typical framing systems (Schafer et al. 2007, 2008). From this testing it was determined that the sheathing rotational restraint could be divided into two parts: one from the sheathing and one from the connector. For the sheathing industry, standard values as provided by the APA, *Panel Design Specification* (APA, 2004) and the Gypsum Association (GA, 2001) are provided. As reported in Schafer et al. (2007, 2008), the gypsum board provided stiffness in-line with or exceeding reported values; but the deformation capacity was severely limited; therefore, it was determined that gypsum board should only be relied upon in a serviceability check, not for strength limit states. Currently, only the Direct Strength Method of AISI S100 Appendix 1 provides a serviceability methodology for distortional buckling; therefore, the design method specifically references Appendix 1 for checking serviceability with gypsum board. For the connector, the experimentally determined values are fit to a simple empirical expression and then provided in tabular form. The testing was conducted with fasteners at 12 in. (305 mm) o.c.; therefore, the Standard requires that this fastener spacing (or less) be maintained.

Design examples and design aids for the application of these methods to floor joists are provided in CFSEI Technical Note G100-08 (Schafer, 2008).

APPENDIX 2, TEST METHODS FOR TRUSS COMPONENTS AND ASSEMBLIES

2.1 Component Structural Performance Load Test

The load test procedures contained in the Standard may be used to confirm or define the design methodology for a *chord member* or a *web member* of a *truss* assembly. This test protocol is intended for use in the testing of *truss* assembly components fabricated using *cold-formed steel structural members*.

Because the flexural strength [*resistance*] of a *truss* member may be bending (yielding or buckling), shear, *web* crippling, or combinations thereof, this test protocol defines what should be considered in regard to a test, but does not define for the testing agency how to do the test. This leaves the selection of the test fixture and loading medium to the discretion of the testing agency. For details of test apparatus and procedures that have been used for such purposes, but in no way should be regarded as mandatory, see Hetrukul and Yu (1978), LaBoube and Yu (1978a, 1978b, 1982), and Yu (2000).

This protocol also outlines the procedures to be followed to define the compression strength [*resistance*] of a *truss* component for static load. Because the compression strength [*resistance*] of a *truss* component may be local buckling or overall column buckling, this procedure defines what to do in regard to performing a test, but does not tell the testing agency how to do the test. This leaves the selection of the test fixture and loading medium to the discretion of the testing agency. It is the responsibility of the *design professional* to determine the appropriate loading rate.

Load tests can be hazardous to the individuals performing or observing the tests, and also can damage the testing fixtures or the structure housing the test setup due to a sudden release of stored energy at failure. Care should be exercised in the preparation of the test setup to ensure that the failure of a test specimen will not result in a secondary collapse of a structural element not involved in the test.

The number of similar components that should be tested will vary with the desired precision and reliability of the information to be obtained and with the purpose of the test.

Loads may be measured using one or more of the following devices. Pressure gages or load cells can be incorporated into a hydraulic loading system. These devices must be calibrated with the jacks or cylinders at different positions of piston travel to ensure a true loading history.

Deflection readings may be taken in a variety of ways. One of the simplest methods is by the use of a taut wire or monofilament line stretched between supports in combination with a mirror-scale located at the desired deflection measurement points. When the taut wire method is used, care must be taken to ensure that the wire will remain under tension during the entire test. This can be accomplished by incorporating a spring into the line or by letting one end run over a pulley with a weight attached to the line. Deflections are read on a scale with a mirror backing. The mirror-scale deflection measurement device is read by visually lining up the top of the wire with its image on the mirror and then reading the scale.

Other commonly used deflection measurement devices are such things as direct reading micrometer dial gages, optical levers used to read scales attached to the *truss*, linearly variable differential transformers (LVDT), or a combination of flexible wire attached at deflection points and monitored remotely through a system of pulleys attached to dial gages.

2.2 Full-Scale Confirmatory Load Test

This test protocol is intended for use in the testing of *truss* assemblies fabricated using *cold-*

formed steel structural members and connections. A confirmatory test is performed with the intent to verify structural performance as defined by calculations in accordance with a recognized specification or standard. Because design was in accordance with a specification or standard, all that is needed is that the tested specimen demonstrates strength [*resistance*] not less than the applicable calculated strength [*resistance*].

The test protocol does not purport to address all of the safety problems associated with its use. It is the responsibility of the user of this protocol to establish appropriate safety and health practices and determine the applicability of regulatory limitation prior to use.

A full-scale *truss* test is the test of a structural system. It is generally accepted that a *safety factor* of 1.5 is for overload and nothing above it should be expected in an in-situ test since the other uncertainties may already have been used up. If the test is conducted under laboratory conditions, 1.65 is a reasonable *safety factor* since fabrication and erection uncertainties are minimized. This factor of 1.65 is consistent with the recommendations of the Steel Joist Institute.

This protocol outlines the procedures to be followed in the static load testing of load-carrying *truss* assemblies. While the procedure tells what to do, it does not tell the testing agency how to do it. This leaves the selection of the test fixture and loading medium to the discretion of the testing agency. It is the responsibility of the *design professional* to determine the appropriate loading rate.

Full-scale load tests of any large-size specimen such as a *truss* can be hazardous to the individuals performing or observing the tests, and also can damage the testing fixtures or the structure housing the test setup due to a sudden release of stored energy at failure. Care should be exercised in the preparation of the test setup to ensure that the failure of a test specimen will not result in a secondary collapse of a structural element not involved in the test.

The test fixture and load application means should be designed with adequate strength [*resistance*] and stiffness to ensure that it is the test specimen that is being tested and not the test fixture.

In a single *truss* test, frequently the support at one end will allow rotation but not translation (a rocker) and the other will allow both rotation and translation (a roller) so as not to induce additional unintentional secondary stresses into the test *truss* as it deforms under load.

The loading devices should result in the desired *truss*-loading situation regardless of whether uniform, concentrated, or a combination of both. The loading system should be such as to allow the application of loads during the test to approximate the overall intended in-service load distribution. Care should be taken to avoid eccentrically applied loads unless this type of loading is desired.

2.3 Full-Scale Structural Performance Load Test

This test protocol is intended for use in the testing of *truss* assemblies fabricated using *cold-formed steel structural members and connections* when calculation of the safe strength [*resistance*] cannot be made in accordance with recognized calculation design specifications or standards.

REFERENCES

- (AFPA, 2005a), *National Design Specification for Wood Construction*, American Forest and Paper Association, Washington, DC, 2005.
- (AFPA, 2005b), *Special Design Provisions for Wind and Seismic*, SDPWS-2005, American Forest and Paper Association, Washington, DC, 2005.
- (AFPA, 1997), *National Design Specification for Wood Construction*, American Forest and Paper Association, Washington, DC, 1997.
- (AFPA, 2001), *Manual for Engineered Wood Construction, Wood Structural Panels Supplement*, American Forest and Paper Association, Washington, DC, 2001.
- (AFPA, 1995), *Wood Frame Construction Manual for One- and Two-Family Dwellings*, American Forest and Paper Association, Washington, DC, 1995.
- (AFPA, 1991), *National Design Specification for Wood Construction*, American Forest and Paper Association, Washington, DC, 1991.
- (AGA, 2012), *Hot Dip Galvanizing For Corrosion Protection – A Specifier’s Guide*, American Galvanizers Association, Aurora, CO, 2006.
- (AISC, 2005a), *Specification for Structural Steel Buildings*, ANSI/AISC 360-05, American Institute of Steel Construction, Chicago, IL, 2005.
- (AISC, 2005b), *Seismic Provisions for Structural Steel Buildings*, ANSI/AISC 341-05, American Institute of Steel Construction, Chicago, IL, 2005.
- (AISI, 2015a), *North American Standard for Cold-Formed Steel Structural Framing*, AISI S240-15, American Iron and Steel Institute, Washington, DC, 2015.
- (AISI, 2015b), *North American Standard for Seismic Design of Cold-Formed Steel Structural Systems*, AISI S400-15, American Iron and Steel Institute, Washington, DC, 2015.
- (AISI, 2015c), *Code of Standard Practice for Cold-Formed Steel Structural Framing*, AISI S202-15, American Iron and Steel Institute, Washington, DC, 2015.
- (AISI, 2015d), *North American Standard for Cold-Formed Steel Framing – Nonstructural Members*, AISI S220-15, American Iron and Steel Institute, Washington, DC, 2015.
- (AISI, 2013), *Standard Test Methods for Determining the Tensile and Shear Strength of Screws*, AISI S904-13, American Iron and Steel Institute, Washington, DC, 2013.
- (AISI, 2012a), *North American Specification for the Design of Cold-Formed Steel Structural Members*, AISI S100-12, American Iron and Steel Institute, Washington, DC, 2012.
- (AISI, 2012b), *North American Standard for Cold-Formed Steel Framing – General Provisions*, AISI S200-12, American Iron and Steel Institute, Washington, DC, 2012.
- (AISI, 2012c), *North American Standard for Cold-Formed Steel Framing – Product Data*, AISI S201-12, American Iron and Steel Institute, Washington, DC, 2012.
- (AISI, 2012d), *North American Standard for Cold-Formed Steel Framing – Floor and Roof System Design*, AISI S210-07 (2012), American Iron and Steel Institute, Washington, D.C., 2012.
- (AISI, 2012e), *North American Standard for Cold-Formed Steel Framing – Wall Stud Design*, AISI S211-07 (2012), American Iron and Steel Institute, Washington, D.C., 2012.
- (AISI, 2012f), *North American Standard for Cold-Formed Steel Framing – Header Design*, AISI S212-07 (2012), American Iron and Steel Institute, Washington, D.C., 2012.
- (AISI, 2012g), *North American Standard for Cold-Formed Steel Framing – Lateral Design*, AISI S213-07 w/S1-09 (2012), American Iron and Steel Institute, Washington, D.C., 2012.

- (AISI, 2012h), *Standard for Cold-Formed Steel Framing – Prescriptive Method for One- and Two-Family Dwellings*, AISI S230-07 w/S2-08 (2012), American Iron and Steel Institute, Washington, D.C., 2012.
- (AISI, 2012i), *North American Standard for Cold-Formed Steel Framing – Truss Design*, AISI S214-12, American Iron and Steel Institute, Washington, DC, 2012.
- (AISI, 2007a), *North American Specification for the Design of Cold-Formed Steel Structural Members*, AISI S100-07, American Iron and Steel Institute, Washington, DC, 2007.
- (AISI, 2007b), *Design Guide for Cold-Formed Steel Framing*, D110-07, American Iron and Steel Institute, Washington, DC, 2007.
- (AISI, 1997), *Cold-Formed Steel Back-To-Back Header Assembly Tests*, Publication RG-9719, American Iron and Steel Institute, Washington, DC, 1997.
- (AISI, 2002), *Cold-Formed Steel Framing Design Guide*, American Iron and Steel Institute, Washington, D.C., 2002.
- (AFPA, 2008), *ASD/LRFD Special Design Provisions for Wind and Seismic*, American Forest & Paper Association, Washington, DC, 2008.
- (APA, 2005), *Fastener Loads for Plywood – Screws*, Technical Note E380D, APA-The Engineered Wood Association, Tacoma, WA, 2005.
- (APA, 2004), *Panel Design Specification*, APA – The Engineered Wood Association, Tacoma, WA, 2004.
- (APA, 2001), *Diaphragms and Shear Walls: Design/Construction Guide*, APA-The Engineered Wood Association, Tacoma, WA, 2001.
- (APA, 2000), *Plywood Diaphragms*, Report 138, APA-The Engineered Wood Association, Tacoma, WA, 2000.
- (APA, 1993), *Wood Structural Panel Shear Walls*, Report 154, APA-The Engineered Wood Association, Tacoma, WA, 1993.
- (ASCE, 2013), *Minimum Design Loads for Buildings and Other Structures*, ASCE 7-10 Including Supplement No. 1, American Society of Civil Engineers, Reston, VA, 2013.
- (ASCE, 2006), *Minimum Design Loads for Buildings and Other Structures*, ASCE 7-05 Including Supplement No. 1, American Society of Civil Engineers, Reston, VA, 2006.
- (ASHRAE, 2009), *ASHRAE Handbook Fundamentals*, American Society of Heating Refrigerating and Air-Conditioning Engineers, Atlanta, GA, 2009.
- (ASTM, 2015), *Standard Specification for Steel Sheet, Carbon, Metallic- and Non-metallic-Coated for Cold-Formed Framing Members*, ASTM A1003/1003M-15, ASTM International, West Conshohocken, PA, 2015.
- (ASTM, 2014a), *Standard Specification for Steel Self-Piercing Tapping Screws for the Application of Gypsum Panel Products or Metal Plaster Bases to Wood Studs or Steel Studs*, ASTM C1002-14, ASTM International, West Conshohocken, PA, 2014.
- (ASTM, 2014b), *Standard Practice for Establishing Conformance to the Minimum Expected Corrosion Characteristics of Metallic, Painted-Metallic, and Nonmetallic-Coated Steel Sheet Intended for Use as Cold-Formed Framing Members*, ASTM A1004/A1004M-99(2014), ASTM International, West Conshohocken, PA, 2014.
- (ASTM, 2013), *Standard Specification for Steel Tapping Screws for Cold-Formed Steel Framing Connections*, ASTM C1513-13, ASTM International, West Conshohocken, PA, 2013.

- (ASTM, 2011a), *Standard Specification for Steel Drill Screws for the Application of Gypsum Panel Products or Metal Plaster Bases to Steel Studs From 0.033 in. (0.84 mm) to 0.112 in. (2.84 mm) in Thickness*, ASTM C954-11, ASTM International, West Conshohocken, PA, 2011.
- (ASTM, 2011b), *Standard Specification for Nonstructural Steel Framing Members*, ASTM C645-11, ASTM International, West Conshohocken, PA, 2011.
- (ASTM, 2011c), *Standard Specification for Load-Bearing (Transverse and Axial) Steel Studs, Runners (Tracks), and Bracing or Bridging for Screw Application of Gypsum Board and Metal Plaster Bases*, ASTM C955-11, ASTM International, West Conshohocken, PA, 2011.
- (ASTM, 2011d), *Standard Specification for Installation of Load Bearing (Transverse and Axial) Steel Studs and Related Accessories*, ASTM C1007-11a, ASTM International, West Conshohocken, PA, 2011.
- (ASTM, 2011e), *Standard Method for Static Load Testing of Framed Floor or Roof Diaphragm Constructions for Buildings*, ASTM E455-11, ASTM International, West Conshohocken, PA, 2011.
- Bolte, W. G. (2003), "Behavior of Cold-Formed Steel Stud-to-Track Connections", Thesis presented to the faculty of the University of Missouri-Rolla in partial fulfillment for the degree Master of Science, 2003.
- (CFSEI, 2012), *Powder Actuated Fasteners in Cold-Formed Steel Construction*, Tech Note F301-12, Cold-Formed Steel Engineers Institute, Washington, DC, 2012.
- (CFSEI, 2011), *Screw Fastener Selection for Cold-Formed Steel Frame Construction*, Tech Note F102-11, Cold-Formed Steel Engineers Institute, Washington, DC, 2011.
- (CFSEI, 2010a), *Top Track Load Distribution Members*, Tech Note W104-10, Cold-Formed Steel Engineers Institute, Washington, DC, 2010.
- (CFSEI, 2010b), *Welding Cold-Formed Steel*, Tech Note 560-b1, Cold-Formed Steel Engineers Institute, Washington, DC, 2010.
- (CFSEI, 2009), *Pneumatically Driven Pins For Wood Based Panel Attachment*, Tech Note F300-09, Cold-Formed Steel Engineers Institute, Washington, DC, 2009.
- (CFSEI, 2007a), *Durability of Cold-Formed Steel Framing Members*, Tech Note D001-07, Cold-Formed Steel Engineers Institute, Washington, DC, 2007.
- (CFSEI, 2007b), *Corrosion Protection for Cold-Formed Steel Framing in Coastal Areas*, Tech Note D200-07, Cold-Formed Steel Engineers Institute, Washington, DC, 2007.
- Cobeen, K. (2010), "Cold-Formed Steel Framing Seismic Design Optimization Phase 1a: Seismic Equivalency Parameter Evaluation," American Iron and Steel Institute Research Report RP10-4, Washington, DC, 2010.
- (CSA, 2014), *Connectors for Masonry*, CAN/CSA-A370-14, Canadian Standards Association, Mississauga, Ontario, Canada, 2014.
- (CSA, 2012), *North American Specification for the Design of Cold-Formed Steel Structural Members*, CAN/CSA S136-12, Canadian Standards Association, Mississauga, Ontario, Canada, 2012.
- (CSA, 2004), *North American Specification for the Design of Cold-Formed Steel Structural Members, 2001 Edition with 2004 Supplement*, CAN/CSA-S136-01 with CAN/CSA-S136S1-04, Canadian Standards Association, Mississauga, Ontario, Canada, 2004.
- (CSA, 2003a), *CSA-O151-78 (R2003), Canadian Softwood Plywood*, Canadian Standards Association, Mississauga, Ontario, Canada, 2003.

- (CSA, 2003b), CSA-O121-78 (R2003), *Douglas Fir Plywood*, Canadian Standards Association, Mississauga, Ontario, Canada, 2003.
- (CSA, 2003c), CAN/CSA-O325.0-92 (R2003), *Construction Sheathing*, Canadian Standards Association, Mississauga, Ontario, Canada, 2003.
- (CSA, 2001), CAN/CSA-O86, *Engineering Design in Wood*, Canadian Standards Association, Mississauga, Ontario, Canada, 2001.
- (CSA,1994), CAN/CSA S16-94, *Limit States Design of Steel Structures*, Canadian Standards Association, Mississauga, Ontario, Canada, 1994.
- Daudet, L. R. (2001), "Recent Research on Stud/Track Connections," October 2001 Newsletter, Light Gauge Steel Engineers Association, Washington, DC, 2001.
- Dawe, J.L. (2005), "Experimental Evaluation of the Strength and Behaviour of 16- and 18-Gauge Cold Formed Steel Top Track Systems - 92 mm and 152 mm, 16" and 24" Spans (W & W/O 2X4 and 2X6 Wood Top Plates)," University of New Brunswick Structural Engineering Laboratory, Saint John, New Brunswick, Canada, 2005.
- Dolan, J.D. (1999), "Monotonic and Cyclic Tests of Long Steel-Frame Shear Walls With Openings," Report No. TE-1999-001, Virginia Polytechnic Institute and State University, Blacksburg, VA, 1999.
- Dolan, J.D., and Easterling, W.S. (2000a), "Monotonic and Cyclic Tests of Light-Frame Shear Walls With Various Aspect Ratios and Tie-Down Restraints," Report No. TE-2000-001, Virginia Polytechnic Institute and State University, Blacksburg, VA, 2000.
- Dolan, J.D., and Easterling, W.S. (2000b), "Effect of Anchorage and Sheathing Configuration on the Cyclic Response of Long Steel-Frame Shear Walls," Report No. TE-2000-002, Virginia Polytechnic Institute and State University, Blacksburg, VA, 2000.
- Elhaji, N.R., and LaBoube, R. A. (2000), "L-Header Testing, Evaluation and Design Methodology," *Proceedings of the 15th International Specialty Conference on Cold-Formed Steel Structures*, Department of Civil Engineering, University of Missouri-Rolla, Rolla, MO, 2000.
- Findlay, P.F. (2005), "Serviceability Issues Pertaining to Load Bearing and Non-Load Bearing Steel Framed Walls," Thesis presented to the faculty of the University of Missouri-Rolla in partial fulfillment of the degree, Master of Science, Rolla, MO, 2005.
- Fisher, J.M. and West, M.A. (1990), *Serviceability Design Considerations for Low-Rise Buildings*, Steel Design Guide Series No. 3, American Institute of Steel Construction, Chicago IL, 1990.
- Fox, S.R. (2006), "The Strength of CFS Floor Assemblies with Clip Angle Bearing Stiffeners," *Proceedings of the 18th International Specialty Conference on Cold-Formed Steel Structures*, Department of Civil Engineering, University of Missouri-Rolla, Rolla, MO, 2006.
- Fox, S.R. (2003), "The Strength of Stiffened CFS Floor Joist Assemblies with Offset Loading," American Iron and Steel Institute, Washington, DC, 2003.
- Fox, S. R., and Schuster, R. (2000), "Lateral Strength of Wind Load Bearing Wall Stud-to-Track Connections," *Proceedings of the Fifteenth International Specialty Conference on Cold-Formed Steel Structures*, University of Missouri-Rolla, Rolla, MO, 2000.
- (GA, 2001), "Gypsum Board Typical Mechanical and Physical Properties," GA-235-01, Gypsum Association, MD, 2001.

- Gerloff, J. R., Huttelmaier, P., and Ford, P. W. (2004), "Cold-Formed Steel Slip-Track Connection," *Proceedings of the Seventeenth International Specialty Conference on Cold-Formed Steel Structures*, University of Missouri-Rolla, Rolla, MO, 2004.
- (ICBO, 1997), *Uniform Building Code*, International Conference of Building Officials, Whittier, CA, 1997.
- (ICBO, 1994), *Uniform Building Code*, International Conference of Building Officials, Whittier, CA, 1994.
- (ICC, 2015), *International Building Code*, International Code Council, Washington, DC, 2015.
- (ICC, 2012), *International Building Code*, International Code Council, Washington, DC, 2012.
- (ICC, 2003), *International Building Code*, International Code Council, Falls Church, VA, 2003.
- LaBoube, R. A. (2004), "Strength of Single L-Headers", Summary Report, Wei-Wen Yu Center for Cold-Formed Steel Structures, Department of Civil Engineering, University of Missouri-Rolla, Rolla, MO, 2004.
- Lee, Y.K. (1995), "Analysis of Gypsum-Sheathed Cold-Formed Steel Wall Stud Panels," Engineering Report in partial fulfillment of the degree Master of Science, Department of Civil Engineering, Oregon State University, Corvallis, OR, 1995.
- Lewis, A.V (2008), *Strength of Cold-Formed Steel Jamb Stud to Track Connections*, MAsc Thesis, Department of Civil Engineering, University of Waterloo, Waterloo, Ontario, Canada, 2008.
- (LGSEA, 1998), *Lateral Load Resisting Elements: Diaphragm Design Values*, Tech Note 558b-1, Light Gauge Steel Engineers Association, Washington, DC, 1998.
- Miller, T. H. (1989), "Studies on the Behavior of Cold-Formed Steel Wall Stud Assemblies," Ph.D. dissertation, Department of Civil Engineering, Cornell University, Ithaca, NY, 1989.
- (NAHB, 2005), "Cold-Formed Steel Walls with Fiberboard Sheathing Shear Wall Testing," NAHB Research Center, Upper Marlboro, MD, 2005.
- (NAHB, 2006), "Cyclic Testing of Fiberboard Shear Walls With Varying Aspect Ratios," NAHB Research Center, Upper Marlboro, MD, 2005.
- (NAHB-RC, 2003), *Cold-Formed Steel Top Load Bearing Tracks*, NAHB Research Center, Upper Marlboro, MD, 2003.
- (NAHB-RC, 2003a), "Testing of Steel Single L-Headers," NAHB Research Center, Upper Marlboro, MD, 2003.
- (NBCC, 2005), *National Building Code of Canada*, NBCC 2005, National Research Council of Canada, Ottawa, Ontario, Canada, 2005.
- (NEHRP, 2000), *NEHRP Recommended Provisions for Seismic Regulations for New Buildings and Other Structures*, Federal Emergency Management Agency (FEMA 368/March 2001), Washington, DC, 2000.
- (NFPA, 2011), *National Electrical Code (NFPA 70)*, National Fire Protection Association, Quincy, MA, 2011.
- (NFPA, 2015), *NFPA 5000, Building Construction and Safety Code*, National Fire Protection Association, Quincy, MA, 2015.
- (NFPA, 2003), *NFPA 5000, Building Construction and Safety Code*, National Fire Protection Association, Quincy, MA, 2003.

- (NRCC, 2010), *User's Guide – NBC 2010 Structural Commentaries (Part 4, of Division B)*, National Research Council of Canada, Ottawa, Ontario, Canada, 2010.
- (NRCC, 2005), *National Building Code of Canada*, 2005 Edition, National Research Council of Canada, Ottawa, Ontario, Canada, 2005.
- Park, R., (1989), "Evaluation of Ductility of Structures and Structural Assemblages from Laboratory Testing," *Bulletin of the New Zealand National Society for Earthquake Engineering* 22(3), 1989.
- (PFS, 1996), "Racking Load Tests for American Fiberboard Association," PFS Corporation, Madison, WI, 1996.
- Ravindra, M.K., and T.V. Galambos (1978), "Load and Resistance Factor Design for Steel," *Journal of the Structural Division*, American Society of Civil Engineers, 104(ST9), 1337-1353, 1978.
- Rokas, D., (2006), "Testing of Light Gauge Steel Frame/9.5mm CSP Panel Shear Walls," Master's Project, Department of Civil Engineering and Applied Mechanics, McGill University, Montreal, Quebec, Canada, 2006.
- Salmon, C.G., and J.E. Johnson (1996), *Steel Structures Design and Behavior*, 4th Edition, Harper Collins, New York, NY, 1996.
- (SBCCI, 1999), *Standard Building Code*, Southern Building Code Congress International, Birmingham, AL, 1999.
- Schafer, B.W. (2008), "Design Aids and Examples for Distortional Buckling," Cold-Formed Steel Engineers Institute, Technical Note G100-08, Washington, DC, 2008.
- Schafer, B.W., R.H. Sangree, Y. Guan(2008), "Floor System Design for Distortional Buckling Including Sheathing Restraint," *Proceedings of the Nineteenth International Specialty Conference on Cold-Formed Steel Structures*, St Louis, MO, October 14-15, 2008.
- Schafer, B.W., R.H. Sangree, Y. Guan (2007), "Experiments on Rotational Restraint of Sheathing," Final Report, American Iron and Steel Institute, , July 2007.
- (SEAOC, 1999), "Recommended Lateral Force Requirements and Commentary," Structural Engineers Association of California, Sacramento, CA, 1999.
- Serrette, R.L. (1995a), "Shear Wall Design and Testing," Newsletter for the Light Gauge Steel Engineers Association, Light Gauge Steel Engineers Association, Nashville, TN, 1995.
- Serrette, R.L., et al. (1995b), "Light Gauge Steel Shear Walls – Recent Test Results," *Proceedings of the Third International Conference on Steel and Aluminum Structures*, MAS Printing Co., Istanbul, Turkey, 1995.
- Serrette, R.L. (1996), "Shear Wall Values for Light Weight Steel Framing," Final Report, Santa Clara University, Santa Clara, CA, 1996.
- Serrette, R.L. (1997), "Additional Shear Wall Values for Light Weight Steel Framing," Final Report, Santa Clara University, Santa Clara, CA, 1997.
- Serrette, R.L. (2002), "Performance of Cold-Formed Steel-Framed Shear Walls: Alternative Configurations," Final Report: LGSRG-06-02, Santa Clara University, Santa Clara, CA, 2002.
- Serrette, R., et al. (2006), "Cold-Formed Steel Frame Shear Walls Utilizing Structural Adhesives," *Journal of Structural Engineering*, American Society of Civil Engineers, Reston, VA, 2006.

- Serrette, R.L. and K. Chau(2003), "Estimating the Response of Cold-Formed Steel-Frame Shear Walls," Santa Clara University, Santa Clara, CA, 2003.
- (SFA, 2008), *Thermal Design and Code Compliance for Cold-Formed Steel Walls*, Steel Framing Alliance, Washington, DC, 2008.
- Sokol, M.A., R.A LaBoube and W.W. Yu (1999), "Determination of the Tensile and Shear Strengths of Screws and the Effect of Screw Patterns on Cold-Formed Steel Connections," Civil Engineering Study 98-3, Cold-Formed Steel Series, Center for Cold-Formed Steel Structures, University of Missouri-Rolla, Rolla, MO., 1999.
- Stephens, S.F., and R.A. LaBoube (2000), "Structural Behavior of Cold-Formed Steel Header Beams for Residential Construction," *Proceedings of the Fifteenth International Specialty Conference on Cold-Formed Steel Structures*, Department of Civil Engineering University of Missouri-Rolla, Rolla, MO, 2000.
- Stephens, S.F. (2001), "Behavior of Cold-Formed Steel Header Beams," Ph.D. dissertation, University of Missouri-Rolla, Rolla, MO, 2001.
- Stone, T.A. and R.A. LaBoube (2005), "Behavior of Built-Up Cold-Formed Steel I-Sections," *Thin-Walled Structure*, Elsevier Ltd, 43, 2005.
- Tarpy, T.S. (1980), "Shear Resistance of Steel-Stud Walls Panels," *Proceedings of the Fifth International Specialty Conference on Cold-Formed Steel Structures*, University of Missouri-Rolla, Rolla, MO, 1980.
- Tarpy, T.S., and J.D. Girard (1982), "Shear Resistance of Steel-Stud Wall Panels," *Proceedings of the Sixth International Specialty Conference on Cold-Formed Steel Structures*, University of Missouri-Rolla, Rolla, MO, 1982.
- Tarpy, T.S., and S.F. Hauenstein (1978), "Effect of Construction Details on Shear Resistance of Steel-Stud Wall Panels," Project No. 1201-412, Department of Civil Engineering, Vanderbilt University, Nashville, TN, 1978.
- Tarpy, T.S., and A.R. McBrearty (1978), "Shear Resistance of Steel-Stud Wall Panels with Large Aspect Ratios," Report No. CE-USS-2, Department of Civil Engineering, Vanderbilt University, Nashville, TN, 1978.
- Tarpy, T.S., and C.S. McCreless (1976), "Shear Resistance Tests on Steel-Stud Wall Panels," Department of Civil Engineering, Vanderbilt University, Nashville, TN, 1976.
- Winter, G. (1960), "Lateral Bracing of Columns and Beams," *Transactions No. 125*, American Society of Civil Engineers, Reston, VA, 1960.
- Wood, L. (1960), "Relation of Strength of Wood to Duration of Load," U.S. Department of Agriculture, Forest Products Laboratory, Report No. 1916, Madison, WI, 1960.
- Yu, C (2007), "Steel Sheet Sheathing Options for Cold-Formed Steel Framed Shear Wall Assemblies Providing Shear Resistance," Report No. UNT-G76234, Department of Engineering Technology, University of North Texas, Denton, TX, 2007.
- Yu, C., Yujie Chen (2009), "Steel Sheet Sheathing Options for Cold-Formed Steel Framed Shear Wall Assemblies Providing Shear Resistance - Phase 2," Report No. UNT-G70752, Department of Engineering Technology, University of North Texas, Denton, TX, 2009.
- Yu, W.W. and R.A. LaBoube (2010), *Cold-Formed Steel Design*, 4th Edition, John Wiley & Sons, New York, NY, 2010.

Advisory Note: The Light Gauge Steel Engineers Association (LGSEA) in 2006 changed its name to the Cold-Formed Steel Engineers Association (CFSEI). CFSEI is located at AISI headquarters in Washington, DC.



25 Massachusetts Avenue NW
Suite 800
Washington, DC 20001
www.steel.org





**American
Iron and Steel
Institute**

25 Massachusetts Avenue NW
Suite 800
Washington, DC 20001
www.steel.org

