

NOTE:
Please read all instructions
carefully before using this
product

Table of Contents

Safety Notice

Hardware Pack

Assembly Instruction

Parts List

Resistance Chart

Warranty

Ordering Parts

Model
MWM-980

Retain This
Manual for
Reference

08-07-09

OWNER'S
MANUAL

IMPEX
FITNESS PRODUCTS

MARCY[®] MWM 980 HOME GYM

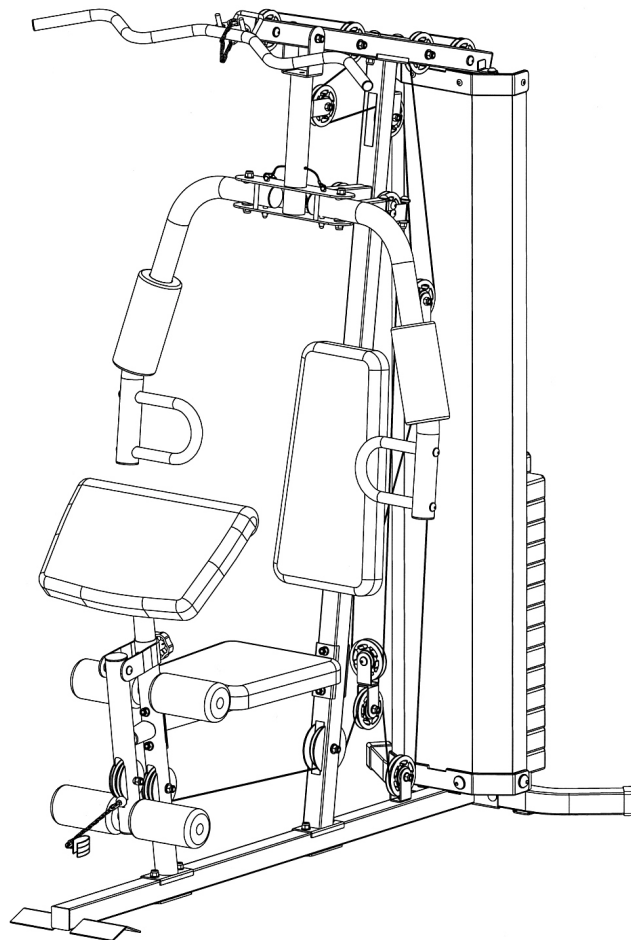

IMPEX[®] INC.

14777 DON JULIAN RD., CITY OF INDUSTRY, CA 91746

Tel: (800) 999-8899 Fax: (626) 961-9966

www.impex-fitness.com

info@impex-fitness.com

TABLE OF CONTENTS

BEFORE YOU BEGIN.....	1
IMPORTANT SAFETY NOTICES.....	2
HARDWARE IDENTIFIER.....	4
ASSEMBLY INSTRUCTIONS.....	6
PARTS LIST.....	24
RESISTANCE CHART.....	25
WARRANTY.....	26
ORDERING PARTS.....	26

BEFORE YOU BEGIN

Thank you for selecting the MARCY MWM-980 HOME GYM by IMPEX® INC. For your safety and benefit, read this manual carefully before using the machine. As a manufacturer, we are committed to provide you complete customer satisfaction. If you have any questions, or find there are missing or damaged parts, we guarantee you complete satisfaction through direct assistance from our factory. To avoid unnecessary delays, *please call our TOO-FREE customer service number*. Our Customer Service Agents will provide immediate assistance to you.

Toll-Free Customer Service Number

1-800-999-8899

Mon. – Fri. 9 a.m. – 5 p.m. PST

www.impex-fitness.com

info@impex-fitness.com

IMPORTANT SAFETY NOTICE

PRECAUTIONS

This exercise machine is built for optimum safety. However, certain precautions apply whenever you operate a piece of exercise equipment. Be sure to read the entire manual before you assemble or operate your machine. In particular, note the following safety precautions:

1. **Keep children and pets away from the machine at all times. DO NOT leave children unattended in the same room with the machine.**
2. Only one person at a time should use the machine.
3. If the user experiences dizziness, nausea, chest pain, or any other abnormal symptoms, STOP the workout at once. CONSULT A PHYSICIAN IMMEDIATELY.
4. Position the machine on a clear, leveled surface. DO NOT use the machine near water or outdoors.
5. Keep hands away from all moving parts.
6. Always wear appropriate workout clothing when exercising. DO NOT wear robes or other clothing that could become caught in the machine. Running or aerobic shoes are also required when using the machine.
7. Use the machine only for its intended use as described in this manual. DO NOT use attachments not recommended by the manufacturer.
8. Do not place any sharp object around the machine.
9. Disabled person should not use the machine without a qualified person or physician in attendance.
10. Before using the machine to exercise, always do stretching exercises to properly warm up.
11. Never operate the machine if the machine is not functioning properly.
12. A spotter is recommended during exercise.
13. Do not intend to insert weight selector pin while the weight stack or top plate is in elevated position.
14. Be certain the weight Selector Pin is completely inserted.
15. Never use dumbbells or other means to increase the weight resistance. Use only weight plates provided by manufacturer.
16. This machine is designed and intended for home and consumer use only, not for commercial use.

CARE AND MAINTENANCE

1. Lubricate moving parts with WD-40 or light oil periodically.
2. Inspect and tighten all parts before using the machine.
3. The machine can be cleaned using a damp cloth and mild non-abrasive detergent. DO NOT use solvents.
4. Maximum user's weight: 300 lbs.

WARNING: BEFORE BEGINNING ANY EXERCISE PROGRAM, CONSULT YOUR PHYSICIAN. THIS IS ESPECIALLY IMPORTANT FOR INDIVIDUALS OVER THE AGE OF 35 OR PERSONS WITH PRE-EXISTING HEALTH PROBLEMS. READ ALL INSTRUCTIONS BEFORE USING ANY FITNESS EQUIPMENT. IMPEX INC. ASSUMES NO RESPONSIBILITY FOR PERSONAL INJURY OR PROPERTY DAMAGE SUSTAINED BY OR THROUGH THE USE OF THIS PRODUCT.

SAVE THESE INSTRUCTIONS.

WARNING LABEL REPLACEMENT



⚠ WARNING
SERIOUS INJURY MAY OCCUR
Do not attempt to exercise or hang from the lat bar while it is placed or stored on the storage hooks

⚠ WARNING
DO NOT MISUSE THIS EQUIPMENT
The possibility of serious injuries or death or both, (if applicable) may occur if caution is not used. Read users manual. All warnings and instructions must be read and followed and proper instructions be obtained prior to us. Replace this label if damaged, illegible or removed. Keep children and pets away from this equipment.

The warning labels shown here have been placed on the Rear Stabilizer and Upper Frame. If the labels are missing or illegible, please call customer service at 1-800-888-8899 for replacements. Apply the labels in the location shown.

HARDWARE PACK

NOTE: The following parts are not drawn to scale. Please use your own ruler to measure the size.

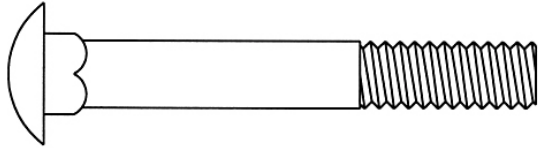

#55 M10 x 2 $\frac{3}{4}$ " Carriage Bolt (Qty 10)

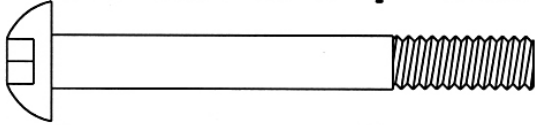

#56 M10 x 2 $\frac{3}{4}$ " Allen Bolt (Qty 9)

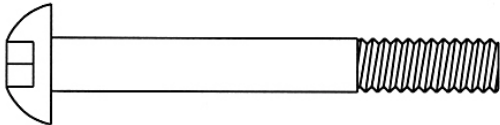

#57 M10 x 2 $\frac{1}{2}$ " Allen Bolt (Qty 2)

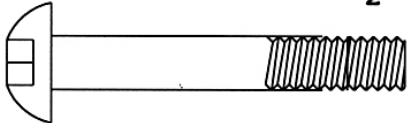

#58 M10 x 2" Allen Bolt (Qty 2)

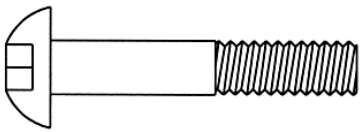

#59 M10 x 1 $\frac{3}{4}$ " Allen Bolt (Qty 9)

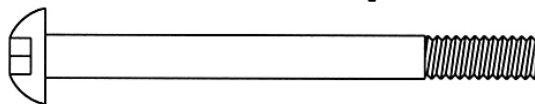

#61 M8 x 2 $\frac{3}{4}$ " Allen Bolt (Qty 2)



#63 M6 x $\frac{3}{4}$ " Allen Bolt (Qty 8)

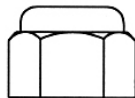

#69 M10 Aircraft Nut (Qty 41)



#70 M6 Aircraft Nut (Qty 2)

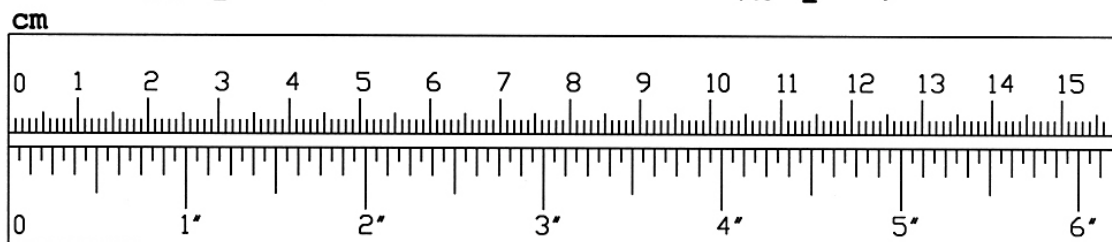

HARDWARE PACK

NOTE: The following parts are not drawn to scale. Please use your own ruler to measure the size.

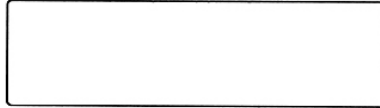

#40 Leg Developer Axle (Qty 1)

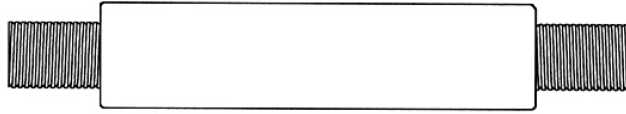

#39 2 $\frac{5}{8}$ " Butterfly Axle (Qty 2)



#38 3" Front Press Axle (Qty 1)

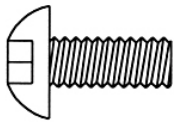

#60 M10 x $\frac{3}{4}$ " Allen Bolt (Qty 13)

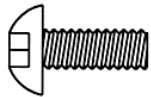

#62 M8 x $\frac{5}{8}$ " Allen Bolt (Qty 6)

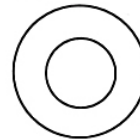
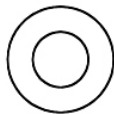

#66 \varnothing $\frac{5}{8}$ " Washer (Qty 8) #65 \varnothing $\frac{3}{4}$ " Washer (Qty 50)

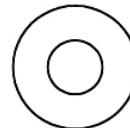

#67 \varnothing $\frac{1}{2}$ " Washer (Qty 10) #68 \varnothing $\frac{3}{4}$ " Spacer (Qty 6)

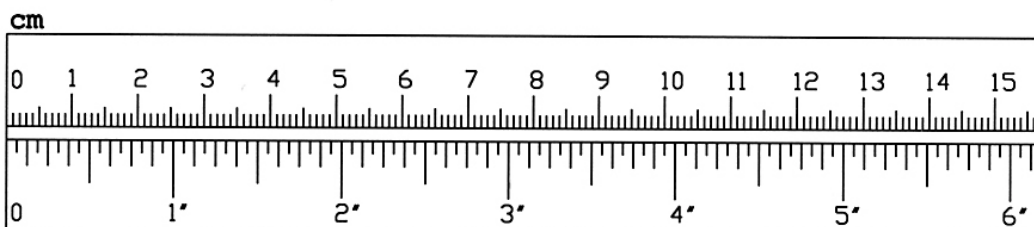

ASSEMBLY INSTRUCTION

Tools Required for Assembling the Machine: Two Adjustable Wrenches and Allen Wrenches. **NOTE:** It is strongly recommended this machine to be assembled by two or more people to avoid possible injury.

STEP 1 (See Diagram 1)

- A.) Insert the two Guide Rods (#17) into the holes on the Rear Stabilizer (#4). Secure each Guide Rod with one M10 x $\frac{3}{4}$ " Allen Bolt (#60) and $\varnothing \frac{3}{4}$ " Washer (#65) from the bottom. **The Guide Rods have holes on the rods to lock the weight stack when not in use. The shorter end of the guide rod with the lock holes will need to be pointed downwards towards the Rear Stabilizer.**
- B.) **Do not tighten all Nuts and Bolts starting from this procedure until instructed to do so.**
- C.) Attach the rear of Base Frame (#3) to the Rear Stabilizer. Secure them with two M10 x 2 $\frac{3}{4}$ " Carriage Bolts (#55), one 2" x 7" U-shaped Bracket (#21), two $\varnothing \frac{3}{4}$ " Washers (#65), and two M10 Aircraft Nuts (#69).
- D.) Attach the Vertical Frame (#2) onto the Base Frame. Secure them with two M10 x 2 $\frac{3}{4}$ " Carriage Bolts (#55), one 1 $\frac{3}{4}$ " x 4 $\frac{3}{4}$ " (#20), two $\varnothing \frac{3}{4}$ " Washers (#65), and two M10 Aircraft Nuts (#69).

DIAGRAM 1

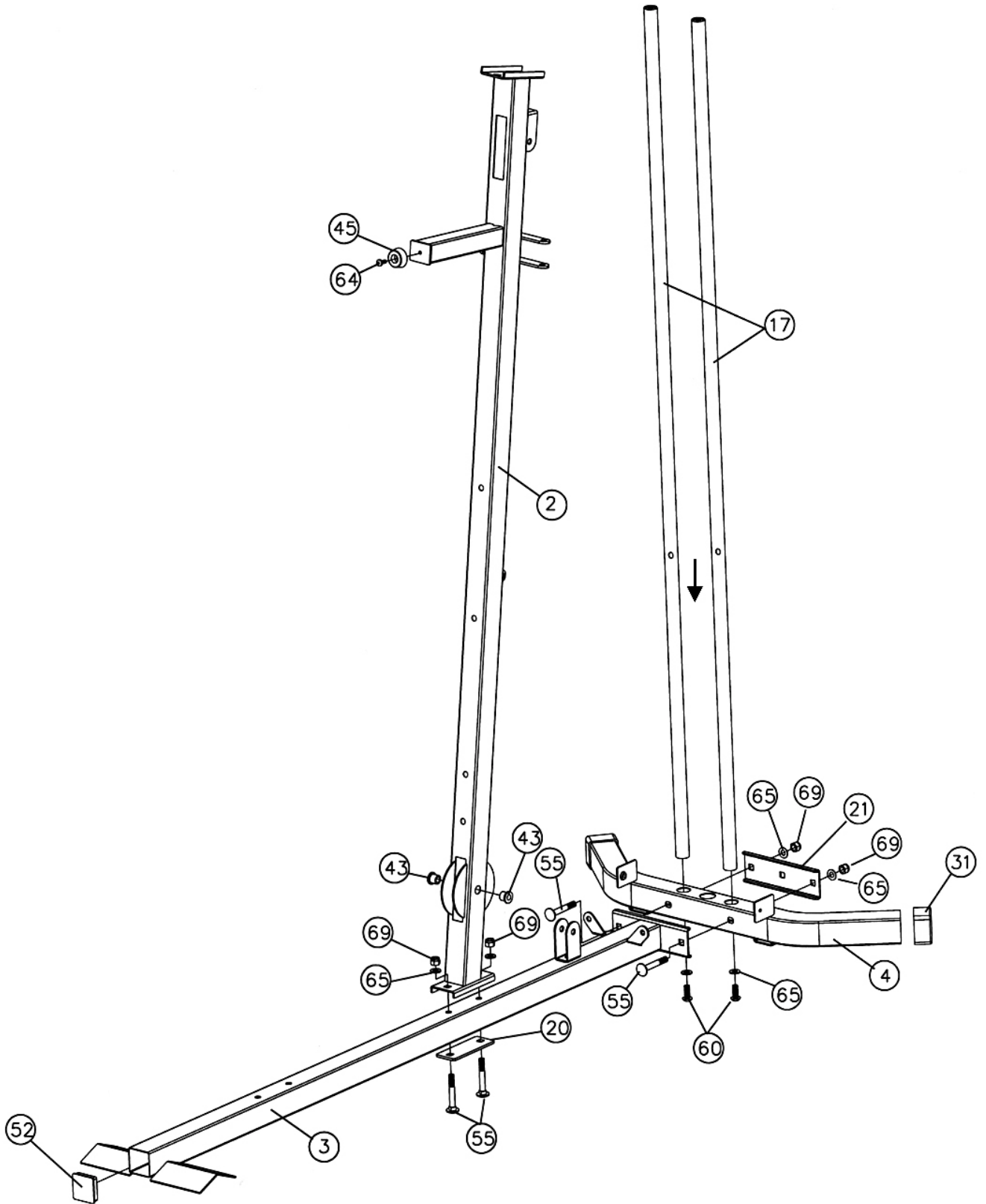

STEP 2 (See Diagram 2)

- A.) Attach the Leg Developer Holder (#5) onto the Base Frame (#3). Secure it with two M10 x 2 ¼" Carriage Bolts (#55), one 1 ¾" x 4 ¾" Bracket (#20), two Ø ¾" Washers (#65), and two M10 Aircraft Nuts (#69).
- B.) Attach the Seat Support (#6) to the Vertical Frame (#2). Secure it with two M10 x 2 ¼" Carriage Bolts (#55), one 1 ¾" x 4 ¾" Bracket (#20), two Ø ¾" Washers (#65), and two M10 Aircraft Nuts (#69).
- C.) Attach the other end of Seat Support to the Leg Developer Holder. Secure it with two M10 x 2 ¼" Allen Bolts (#55), four Ø ¾" Washers (#65), and two M10 Aircraft Nuts (#69).
- D.) Slide two Ø 2 3/8" Weight Plate Rubber Bumpers (#41) onto the two Guide Rods (#17).
- E.) Slide 14 Weight Plates (#36) onto the Guide Rods. **Make sure the deep grooves on the Weight Plates all face the back of the machine and downward.** Align the holes on the Weight Plates. Insert a Selector Rod (#19) through the center hole.
- F.) Slide the Selector Stem (#35) onto the Guide Rods.
- G.) Attach the holes on the Upper Frame (#1) onto the Guide Rods. Place the Upper Frame onto the Vertical Frame (#2).
- H.) Secure the Upper Frame to the Guide Rods with two M10 x ¾" Allen Bolts (#60) and Ø ¾" Washers (#65).
- I.) Secure the Upper Frame to the Vertical Frame with two M10 x 2 ¼" Carriage Bolts (#55), one 1 ¾" x 4 ¾" Bracket (#20), two Ø ¾" Washers (#65), and two M10 Aircraft Nuts (#69).
- J.) Use a Weight Selector Pin (#32) to select the number of Weight Plates to exercise. Attach the ring on Weight Selector Pin's cable onto the Selector Rod. **Note: Each Weight Plate weights approximately 10 lbs. Please refer to the Weight Resistance Chart in page 25.**

DIAGRAM 2

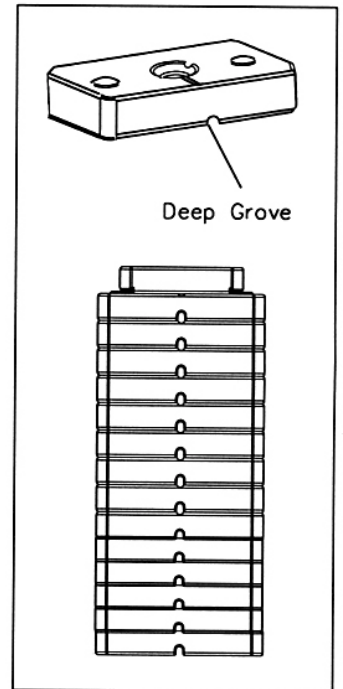
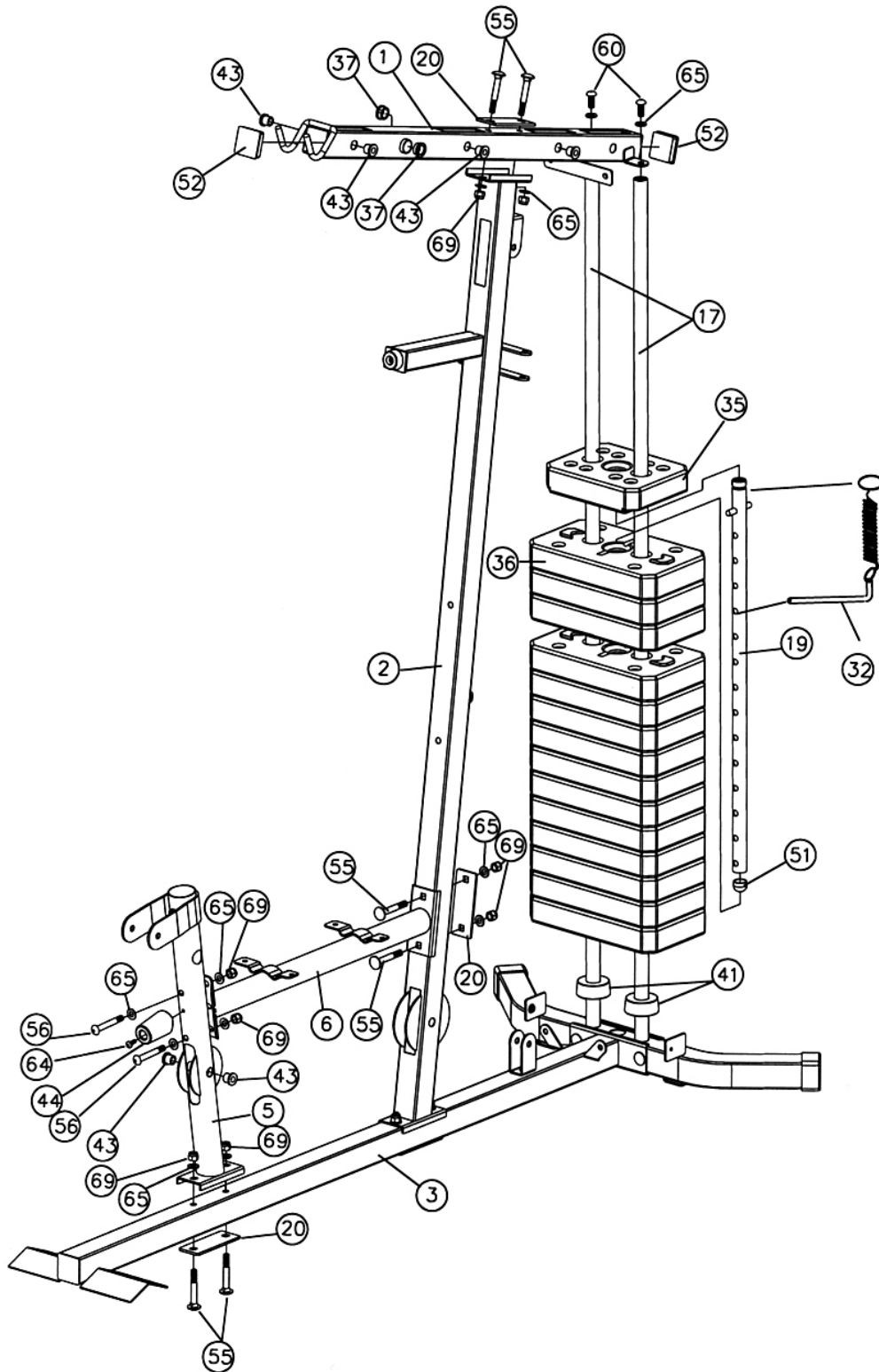

STEP 3 (See Diagram 3)

- A.) Attach the Weight Stack Cover (#16) to the bracket on Rear Stabilizer (#4) and Upper Frame (#1).
- B.) Attach two Weight Stack Cover Brackets (#29) to top and bottom of Weight Stack Cover.
- C.) Secure the Weight Stack cover Bracket, Weight Stack Cover to Upper Frame with four M6 x $\frac{3}{4}$ " Allen Bolts (#63), four $\text{\O} \frac{1}{2}$ " Washers (#67), and two M6 Aircraft Nuts (#70).
- D.) Secure the Weight Stack cover Bracket, Weight Stack Cover to Rear Stabilizer with four M6 x $\frac{3}{4}$ " Allen Bolts (#63) and four $\text{\O} \frac{1}{2}$ " Washers (#67).
- E.) **Securely tighten all Nuts and Bolts installed in Step-1 and Step-2.**

DIAGRAM 3

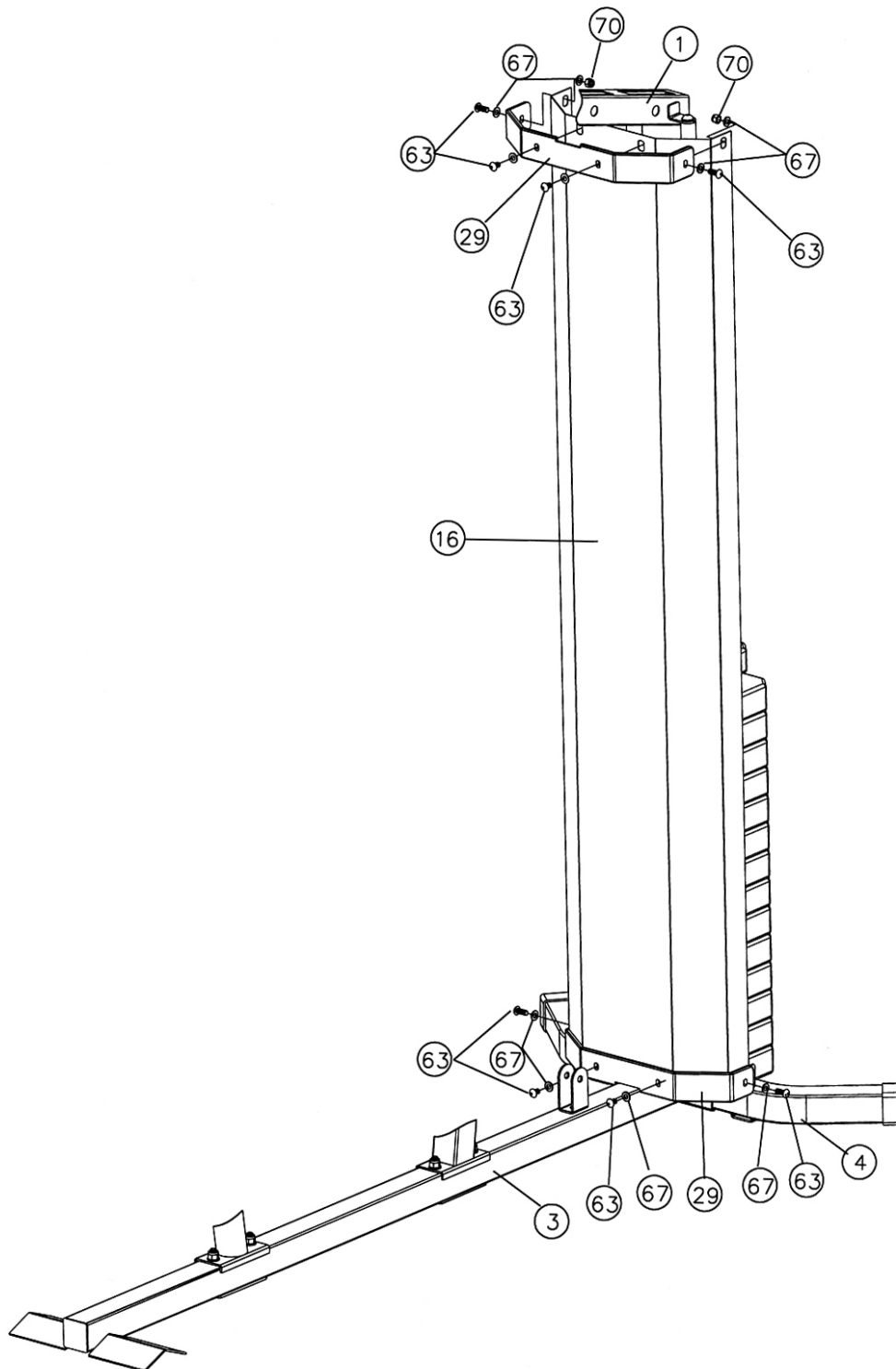

STEP 4 (See Diagram 4)

- A.) Attach the Front Press Base (#8) to the Upper Frame (#1). Secure it with one 3" Front Press Axle (#38), two $\text{\O} \frac{3}{4}$ " Spacers (#68), and two M10 Aircraft Nuts (#69). **Do not over tighten the Nuts.**
- B.) Attach the Right Butterfly (#9) to the open bracket on Front Press Base. Secure it with one 2 5/8" Butterfly Axle (#39), two $\text{\O} \frac{3}{4}$ " Spacers (#68), and two M10 Aircraft Nuts (#69). Push one large Foam Roll (#27) onto the Right Butterfly.
- C.) Attach one Front Press Handle (#11) to the holes on Right Butterfly. Secure it with two M10 x $\frac{3}{4}$ " Allen Bolts (#60) and two $\text{\O} \frac{3}{4}$ " Washers (#65).
- D.) Repeat Procedure B & C to install the Left Butterfly (#10).
- E.) Insert the two Butterfly Lock Pins (#46) into the holes on Front Press Base to lock the Butterflies for Front Press exercise.
- F.) Pull out the Butterfly Lock Pins and insert into the holes on the stopper on the Vertical Frame (#2) for Butterfly exercise.

DIAGRAM 4

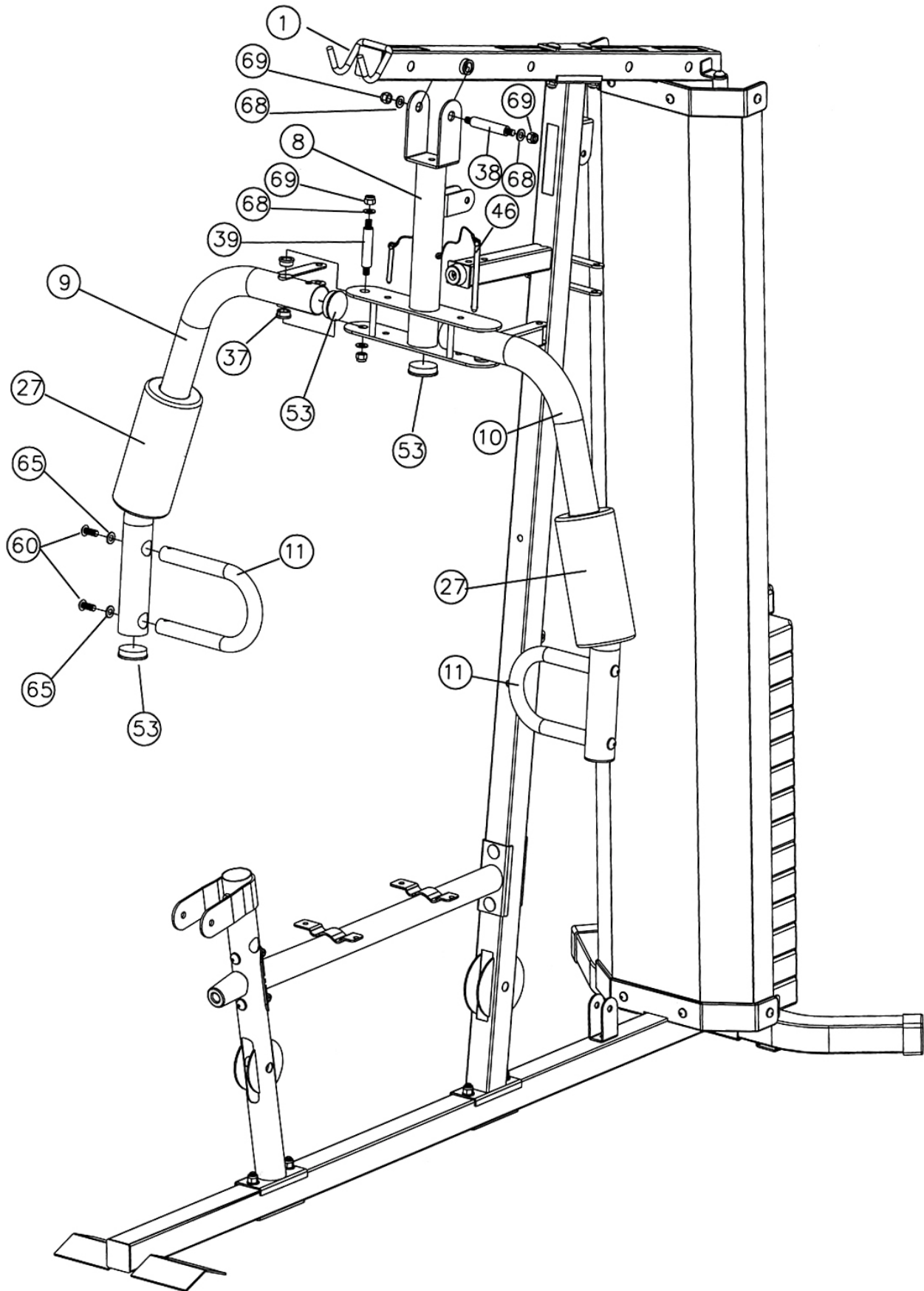

STEP 5 (See Diagram 5)

- A.) Attach the Backrest Board (#24) to the Vertical Frame (#2). Secure it with two M8 x 2 3/4" Allen Bolts (#61) and two Ø 5/8" Washers (#66).
- B.) Attach the Seat Pad (#25) to the Seat Support (#6). Secure it with four M8 x 5/8" Allen Bolts (#62) and two Ø 5/8" Washers (#66).

DIAGRAM 5

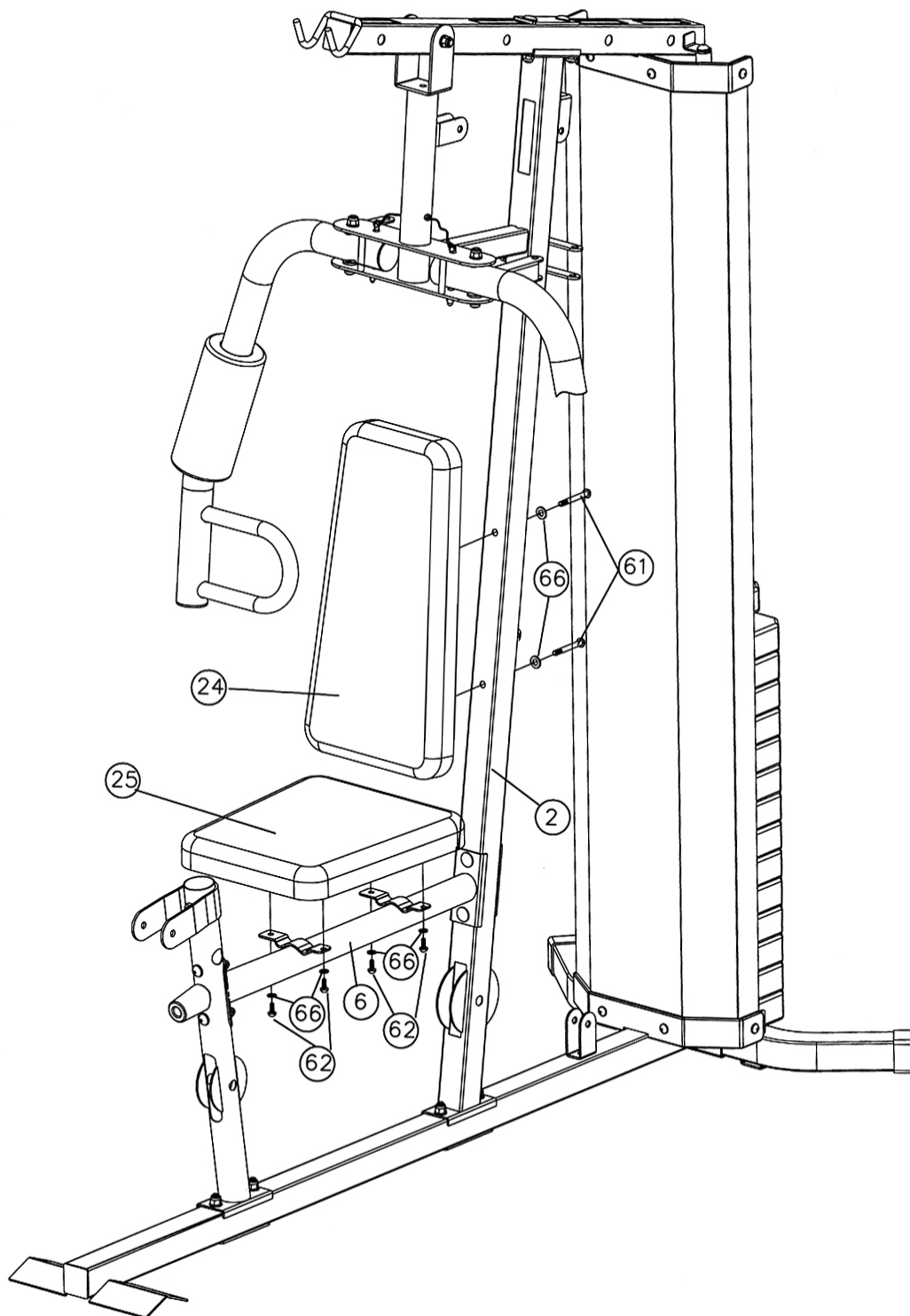

STEP 6 (See Diagram 6)

- A.) Attach one Swivel Pulley Bracket (#14) to the open bracket on the back of Vertical Frame (#2). Secure it with one M10 x 2 ½" Allen Bolt (#57), two Ø ¾" Washers (#65), and one M10 Aircraft Nut (#69). **Do not over tighten the Nut and Bolt. Make sure the Swivel Pulley Bracket can swivel freely.**
- B.) Repeat Procedure A to install the other Swivel Pulley Bracket on the other side.
- C.) Attach two Butterfly Cable Brackets (#12) to the Right & Left Butterfly (#9 & #10). Secure each Butterfly Cable Bracket with one M10 x 2" Allen Bolt (#58), two Ø ¾" Washers (#65), and one M10 Aircraft Nut (#69).
- D.) Attach the Leg Developer (#7) to the Leg Developer Holder (#5). Secure it with one Leg Developer Axle (#40), two M10 x ¾" Allen Bolts (#60), and two Ø ¾" Washers (#65).
- E.) Insert two Foam Tubes (#23) halfway through the holes on Leg Developer Holder and Leg Developer. Push four Foam Rolls (#28) onto the Foam Tubes from both ends.
- F.) Attach the Arm Curl Pad (#26) to Arm Curl Stand (#13). Secure it with two M8 x 5/8" Allen Bolts (#62) and two Ø 5/8" Washers (#66).
- G.) Insert the Arm Stand into the opening on the Leg Developer Holder (#5). Use a Lock Knob (#22) to lock the Arm Curl Stand in position.

DIAGRAM 6

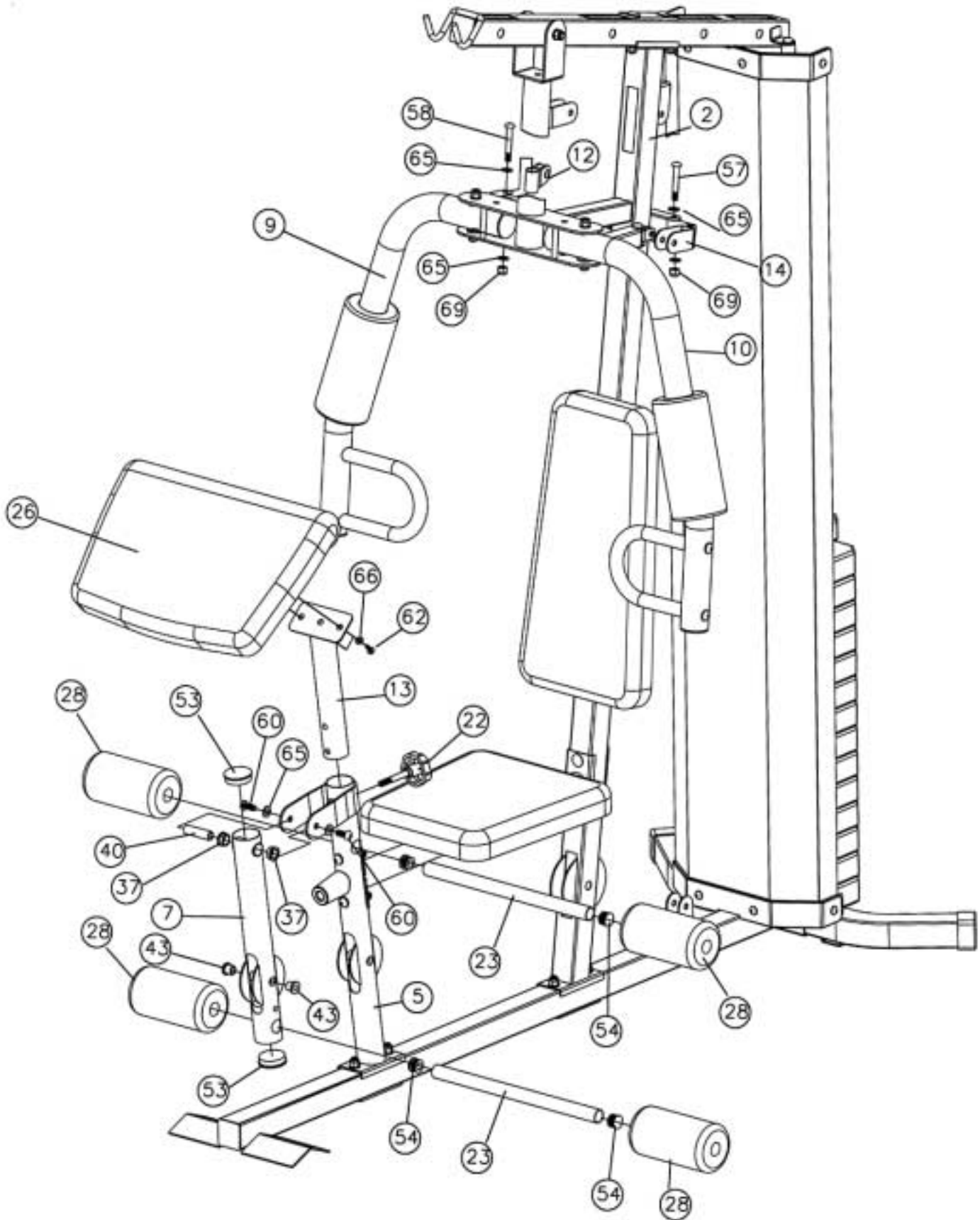

CALBE LOOP

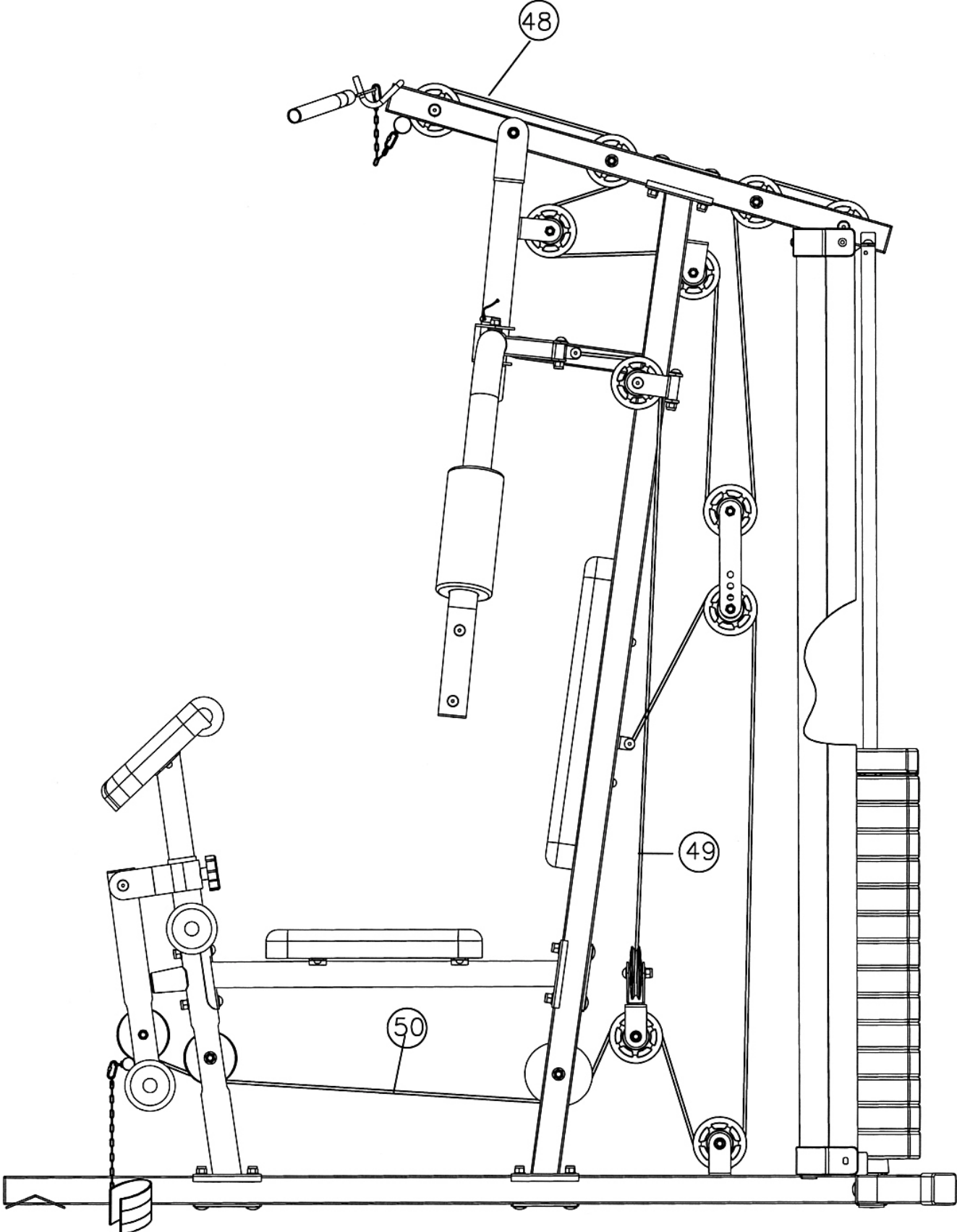

STEP 7 (See Diagram 7 & Cable Loop Diagram)

- A.) Attach the 116" Upper Cable (#48) to the front opening on the Upper Frame.
NOTE: The Ball Stopper on the Cable needs to be underneath the Frame.
- B.) Attach a Pulley (#42) to the opening. Secure it with one M10 x 2 3/4" Allen Bolt (#56), two Ø 7/8" Pulley Bushings (#43) pre-installed on Upper Frame, and one M10 Aircraft Nut (#69).
- C.) Draw the Cable towards the back of the machine to the second opening on the Upper Frame. Repeat Procedure B above to install a Pulley.
- D.) Draw the Cable around the Pulley then pull back to the open bracket on the Front Press Base (#8).
- E.) Attach a Pulley to the bracket. Secure it with one M1 x 3/4" Allen Bolt (#59), two Ø 3/4" Washers (#65), and one M10 Aircraft Nut (#69).
- F.) Draw the Cable around the Pulley then through the opening on the Vertical Frame (#2) to the open bracket on the back of Vertical Frame. Repeat Procedure E to install a Pulley.
- G.) Draw the Cable over the Pulley and pull the Cable downwards. Attach a Pulley to the upper hole on the two Double Floating Pulley Brackets (#30). Repeat Step E above to install another Pulley with a Cable Retainer (#74). Let the Bracket hanging for now.
- H.) Draw the Cable around the Pulley then pull upwards the third opening on the Upper Frame. Repeat Procedure B to install a Pulley.
- I.) Draw the Cable to the rear opening on Upper Frame. Repeat Procedure B to install a Pulley.
- J.) Draw the Cable downwards between the two Guide Rods (#17) to the Selector Rod (#19). Securely thread the bolt on the end of the Cable into the Selector Rod.

DIAGRAM 7

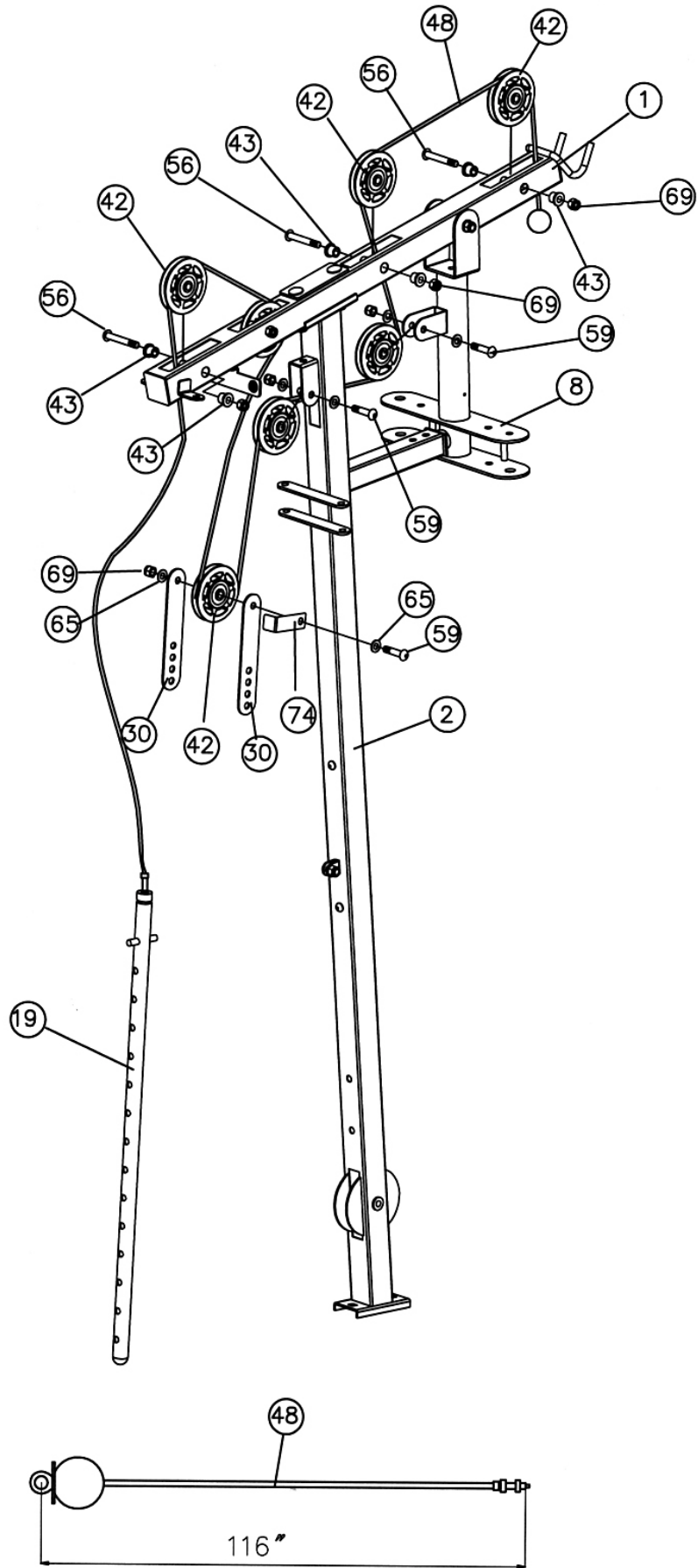

STEP 8 (See Diagram 8 & Cable Loop Diagram)

- A.) Attach one end of the 91" Butterfly Cable (#49) to one Butterfly Cable Bracket (#12). Secure it with one M10 x $\frac{3}{4}$ " Allen Bolt (#60) and one M10 Aircraft Nut (#65).
- B.) Draw the Cable towards the right open Swivel Pulley Bracket (#14).
- C.) Attach a Pulley (#42) to the bracket. Secure it with one M10 x $1\frac{3}{4}$ " Allen Bolt (#59), two $\text{\O} \frac{3}{4}$ " Washers (#65), and one M10 Aircraft Nut (#69).
- D.) Draw the Cable over the Pulley then pull downward. Attach the Cable to an Angled Double Floating Pulley Bracket (#15). Repeat Procedure C to install a Pulley. Let the Bracket hanging for now.
- E.) Draw the Cable around the Pulley and pull upward to the left open Swivel Pulley Bracket. Install another Pulley as described in Step C above.
- F.) Draw the Cable over the Pulley and attach the end to the open Butterfly Cable Bracket. Repeat Procedure A to secure the Butterfly Cable.

DIAGRAM 8

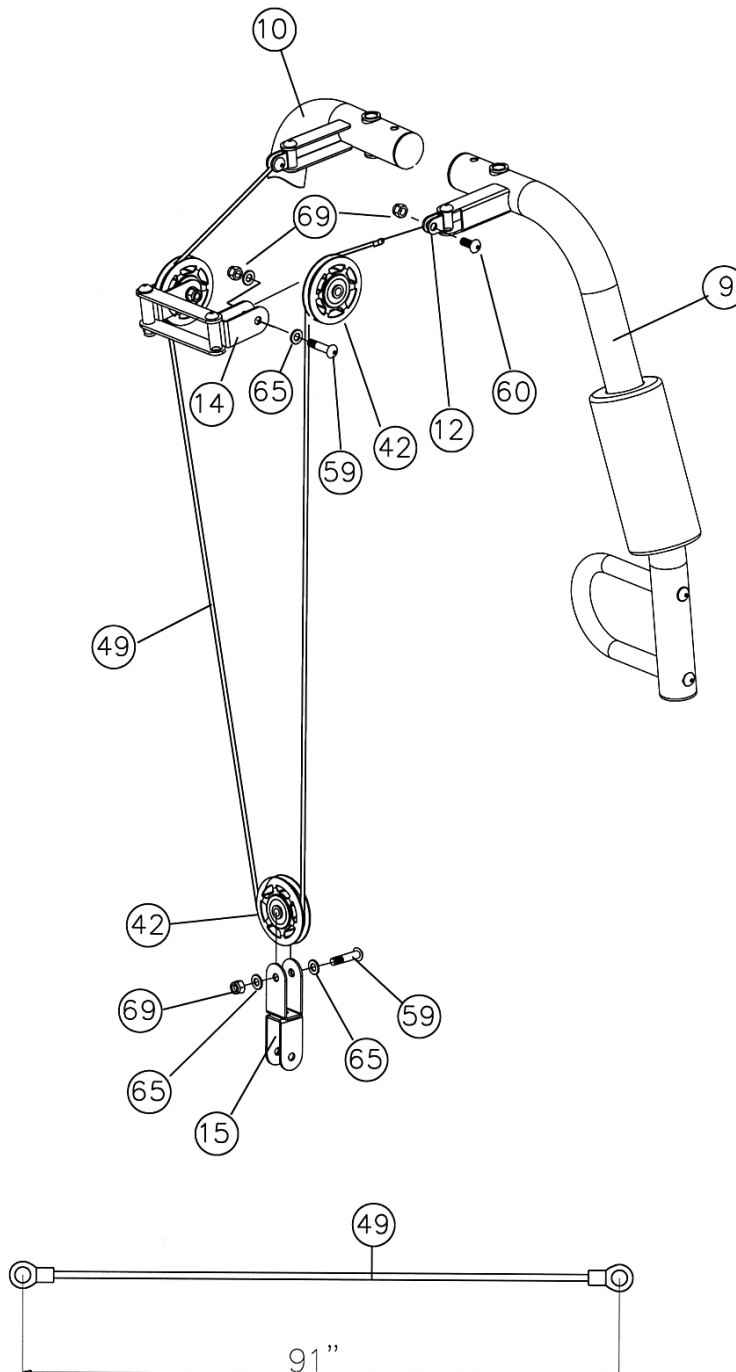

STEP 9 (See Diagram 9 & Cable Loop Diagram)

- A.) Attach the 134" Lower Cable (#50) to the opening on the bottom of the Leg Developer (#7).
- B.) Attach a Pulley (#42) to the opening. Secure it with one M10 x 2 3/4" Allen Bolt (#56), two Ø 7/8" Pulley Bushings (#43) pre-installed on the holes, and one M10 Aircraft Nut (#69).
- C.) Draw the Cable underneath the Pulley towards the back of the machine through the opening on the Leg Developer Holder (#5). Repeat Procedure B to install a Pulley.
- D.) Draw the Cable underneath the Pulley through the opening on bottom of Vertical Frame (#2). Repeat Procedure B to install a Pulley.
- E.) Pull the Cable upward to the Angled Double Floating Pulley Brackets (#15) previously installed in Step 8.
- F.) Attach a Pulley to the bracket. Secure the Pulley to the selected hole with one M10 x 1 3/4" Allen Bolt (#59), two Ø 3/4" Washers (#65), and one M10 Aircraft Nut (#69).
- G.) Draw the Cable around the Pulley and downward to the open bracket on Base Frame (#3). Repeat Procedure F to install another Pulley.
- H.) Draw the Cable around the Pulley then pull upward to the Double Floating Pulley Bracket (#30) previously installed in Step-7. Repeat Procedure F to install a Pulley with a Cable Retainer (#74).
- I.) Draw the Cable around the Pulley to the bracket on the back of Vertical Frame. Secure the end of Cable to the bracket with one M10 x 3/4" Allen Bolt (#60) and one M10 Aircraft Nut (#69).
- J.) If the whole Cable system is too loose, adjust the tension of the cable system by moving up or down the lower pulley on the Double Floating Pulley Bracket. Moving up the pulley up will increase the tension in the pulley system; conversely, lowering the pulley will decrease the tension.

DIAGRAM 9

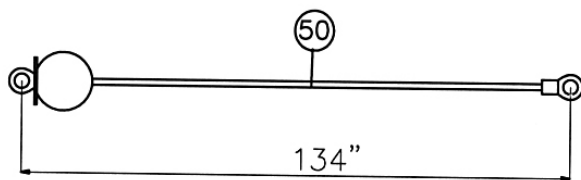
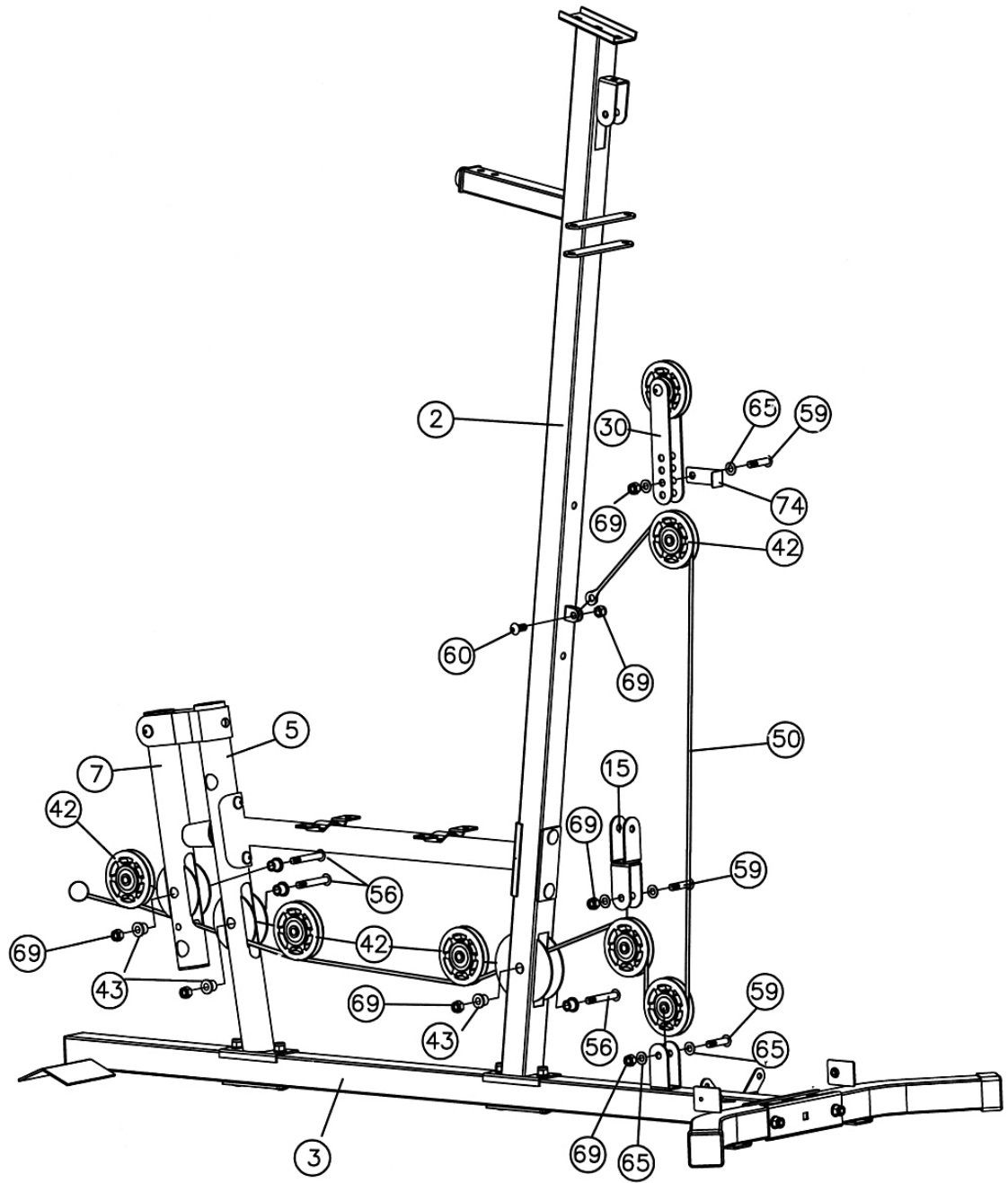

STEP 10 (See Diagram 10)

- A.) Attach Lat Bar (#18) to the Upper Cable (#48) with two C-Clips (#34) and one Chain (#33) when doing Lat Pull exercises.
- B.) Attach Lat Bar to the Lower Cable (#50) with two C-Clips (#34) and one Chain (#33) when doing Arm Curl exercises
- C.) Remove Arm Curl Stand. Replace Lat Bar with the Ankle Strap (#47) to the Lower Cable (#50) for various leg exercises.
- D.) Insert a Lock Pin (#72) through the hole on Guide Rod and lock with a Combination Lock (#73) to prevent any un-authorized usage of the machine.
- E.) Unlock the Lock and attach it to Selector Rod before using the machine.

DIAGRAM 10

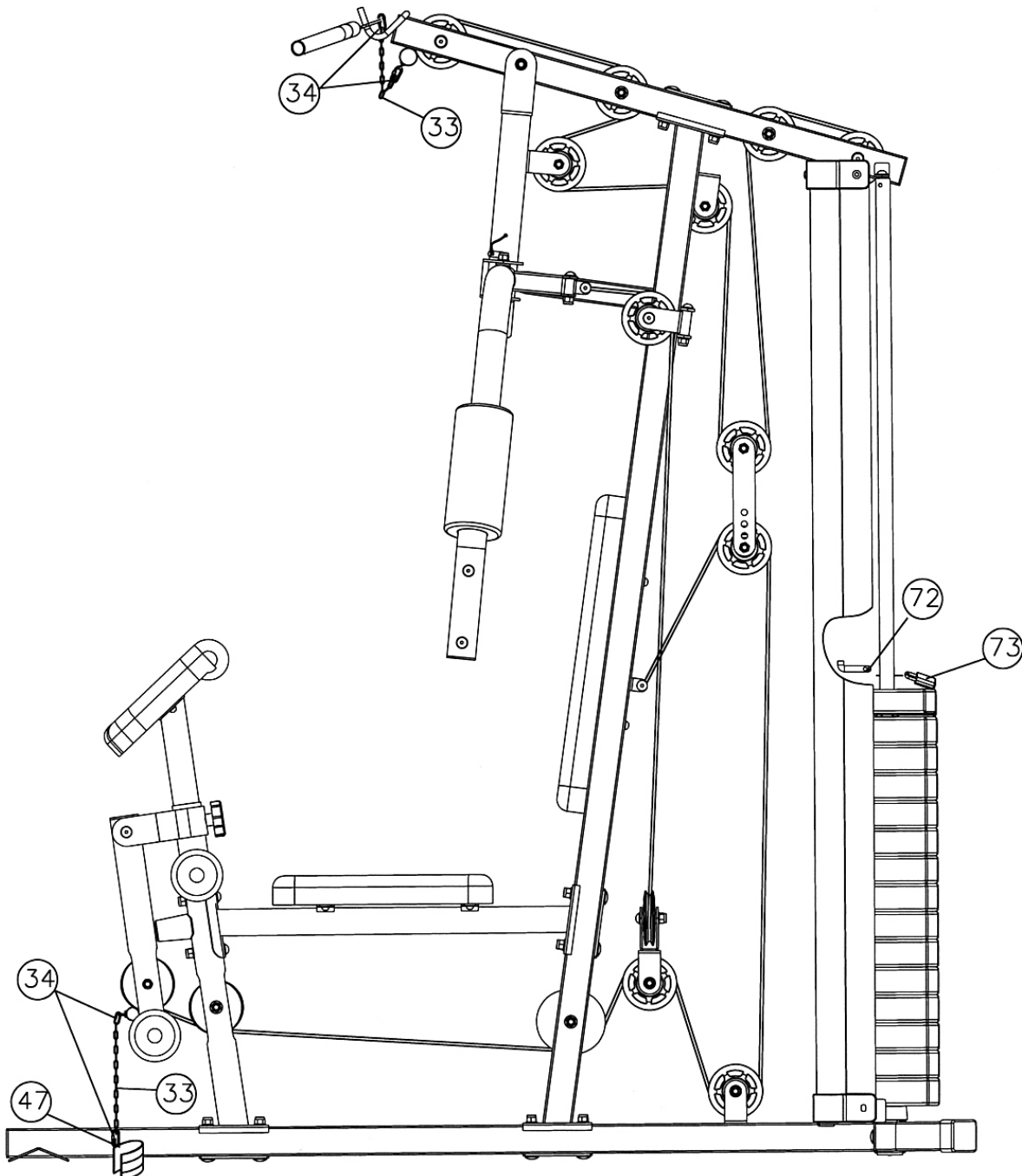

Set up the Lock Combination

- A.) The combination is pre-set at 0-0-0 by the factory.
- B.) Turn the dials to 0-0-0 and aligned to the Combination Set Up Line.
- C.) Pull out the shackle and turn 180°.
- D.) Press down on the shackle.
- E.) Turn the dials (aligned to the Combination Set Up Line) to your desired combination.
- F.) Pull out the shackle and twist back to normal position and the combination are set.
- G.) Repeat Procedure C to F to re-set the combination.

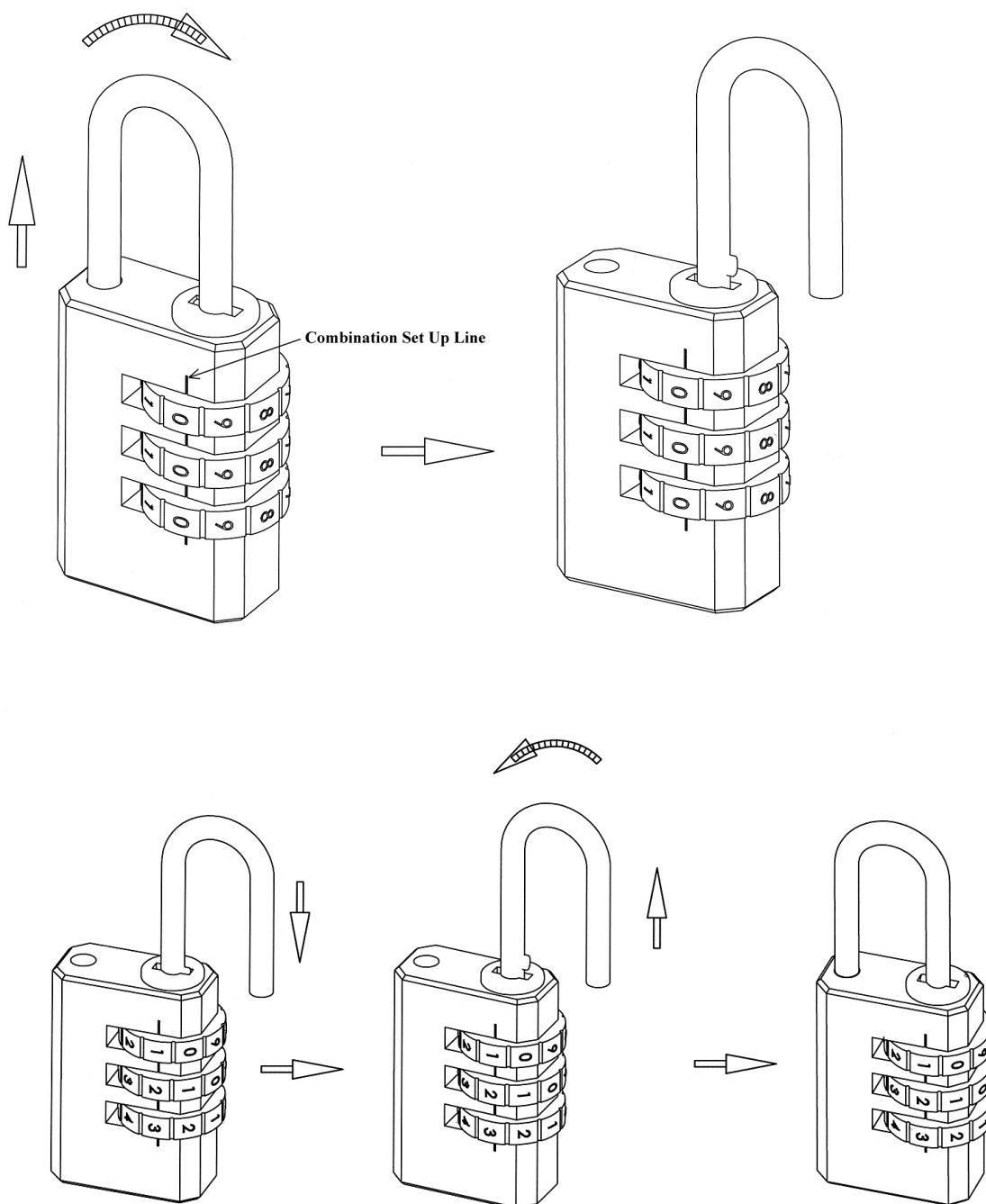

PARTS LIST

KEY NO.	DESCRIPTION	Q'ty			
1	Upper Frame	1	51	Ø 1" Cone-shaped End Cap	1
2	Vertical Frame	1	52	2" Square End Cap	3
3	Base Frame	1	53	Ø 2" End Cap	7
4	Rear Stabilizer	1	54	Ø 1" End Cap	6
5	Leg Developer Holder	1	55	M10 x 2 ¾" Carriage Bolt	10
6	Seat Support	1	56	M10 x 2 ¾" Allen Bolt	9
7	Leg Developer	1	57	M10 x 2 ½" Allen Bolt	2
8	Front Press Base	1	58	M10 x 2" Allen Bolt	2
9	Right Butterfly	1	59	M10 x 1 ¾" Allen Bolt	9
10	Left Butterfly	1	60	M10 x ¾" Allen Bolt	13
11	Front Press Handle	2	61	M8 x 2 ¾" Allen Bolt	2
12	Butterfly Cable Bracket	2	62	M8 x 5/8" Allen Bolt	6
13	Arm Curl Stand	1	63	M6 x ¾" Allen Bolt	8
14	Swivel Pulley Bracket	2	64	M6 x 5/8" Philips Screw	2
15	Angled Double Floating Pulley Bracket	1	65	Ø ¾" Washer	50
16	Weight Stack Cover	1	66	Ø 5/8" Washer	8
17	Guide Rod	2	67	Ø ½" Washer	10
18	Lat Bar	1	68	Ø ¾" Spacer	6
19	Selector Rod	1	69	M10 Aircraft Nut	41
20	1 ¾" x 4 ¾" Bracket	4	70	M6 Aircraft Nut	2
21	2" x 7" U-shaped Bracket	1	71	ST5 Screw	2
22	Lock Knob	1	72	Lock Pin	1
23	Foam Tube	2	73	Combination Lock	1
24	Backrest Board	1	74	Cable Retainer	2
25	Seat Pad	1			
26	Arm Curl Pad	1			
27	Ø 1 7/8" x 8 5/8" Foam Roll	2			
28	Ø 7/8" x 7" Foam Roll	4			
29	Weight Stack Cover Bracket	2			
30	Double Floating Pulley Bracket	2			
31	Rear Stabilizer End Cap	2			
32	Weight Selector Pin	1			
33	Chain	2			
34	C-clip	4			
35	Selector Stem	1			
36	Weight Plate	14			
37	Ø 1" Bushing	8			
38	3" Front Press Axle	1			
39	2 5/8" Butterfly Axle	2			
40	Leg Developer Axle	1			
41	Ø 2 3/8" Weight Plate Rubber Bumper	2			
42	Pulley	16			
43	Ø 7/8" Pulley Bushing	14			
44	Ø 1 7/8" x 2 ½" Rubber Bumper	1			
45	Ø 1 ½" x 5/8" Rubber Bumper	1			
46	Butterfly Lock Pin	2			
47	Ankle Strap	1			
48	116" Upper Cable	1			
49	91" Butterfly Cable	1			
50	134" Lower Cable	1			

MWM980 WEIGHT RESISTANCE CHART

Weight Plate	Front Press	Butterfly	Lat Pull	Low Pulley
1	31	15	30	30
2	44	20	40	40
3	57	25	50	50
4	70	30	60	60
5	83	35	70	70
6	96	40	80	80
7	109	45	90	90
8	122	50	100	100
9	135	55	110	110
10	148	60	120	120
11	161	65	130	130
12	174	70	140	140
13	187	75	150	150
14	200	80	160	160

Note: Each plate weights 10 lbs.

Numbers are approximate. Actual weights may vary.

Values for Butterfly are for each arm.

IMPEX[®] INC.

LIMITED WARRANTY

IMPEX Inc. ("IMPEX[®]") warrants this product to be free from defects in workmanship and material, under normal use and service conditions, for a period of two years on the Frame from the date of purchase. This warranty extends only to the original purchaser. IMPEX's obligation under this Warranty is limited to replacing or repairing, at IMPEX's option.

All returns must be pre-authorized by IMPEX. Pre-authorization may be obtained by calling IMPEX Customer Service Department at 1-800-999-8899. All freights on products returned to IMPEX must be prepaid by the customer. This warranty does not extend to any product or damage to a product caused by or attributable to freight damage, abuse, misuse, improper or abnormal usage or repairs not provided by an IMPEX authorized service center or for products used for commercial or rental purposes. No other warranty beyond that specifically set forth above is authorized by IMPEX.

IMPEX is not responsible or liable for indirect, special or consequential damages arising out of or in connection with the use or performance of the product or other damages with respect to any economic loss, loss of property, loss of revenues or profits, loss of enjoyments or use, costs of removal, installation or other consequential damages or whatsoever natures. Some states do not allow the exclusion or limitation of incidental or consequential damages. Accordingly, the above limitation may not apply to you.

The warranty extended hereunder is in lieu of any and all other warranties and any implied warranties of merchantability or fitness for a particular purpose is limited in its scope and duration to the terms set forth herein. Some states do not allow limitations on how long an implied warranty lasts. Accordingly, the above limitation may not apply to you.

This warranty gives you specific legal right. You may also have other rights which vary from state to state.

Register on-line at www.impex-fitness.com

**IMPEX[®] INC.
14777 Don Julian
City of Industry, CA 91746**

ORDERING REPLACEMENT PARTS

Replacement parts can be ordered by calling our Customer Service Department toll-free at **1-800-999-8899** during our regular business hours: Monday through Friday, 9 am until 5 pm Pacific standard time.

info@impex-fitness.com

When ordering replacement parts, always give the following information.

1. Model
2. Description of Parts
3. Part Number
4. Date of Purchase