

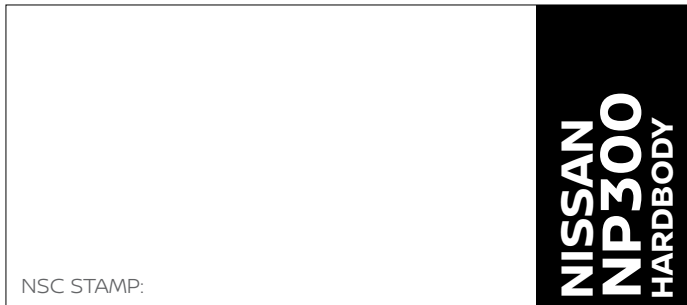

Innovation
that excites

NISSAN NP300 HARDBODY



NSC STAMP:

WWW.NISSANAFRICA.COM | D22201701LHDE

PROVEN HARDBODY



PROVEN DURABILITY

AFRICAN BORN, AFRICAN HARDENED

Tested in the most unforgiving conditions Africa has to offer, the NISSAN NP300 HARDBODY has proven over the years that it's made to last. Specifically engineered for harsh environments, all NP300 HARDBODY models incorporate a heavy duty axle with reinforced chassis and suspension to absorb the impact of the toughest terrain.

The NISSAN NP300 HARDBODY has a backbone to match, too. A full-length, closed section ladder-type frame with high-tensile-strength steel – stronger than conventional steel – in strategic areas ensures improved structural rigidity. This means increased torsional stiffness, helping to deliver enhanced performance on- and off-road, whatever the load. Further proof that the NISSAN NP300 HARDBODY is the pickup built to tackle any challenge Africa has to offer.



2WD Single Cab Base Grade



4WD Single Cab Mid Grade



4WD Double Cab Mid Grade



4WD Double Cab High Grade



PROVEN PERFORMANCE

BUILT FOR THE LONG HAUL, DESIGNED TO PERFORM

ENGINE

Nissan diesel engines have built an enviable reputation for clean firing, smoother acceleration and drivability, resulting in impressive fuel efficiency with reduced emissions. The result is a quieter ride with less vibration, wear and tear and an overall decrease in maintenance costs.

The NISSAN NP300 HARDBODY's intercooled 2.5 litre common rail turbo diesel engine balances toughness and power with excellent fuel efficiency, using the combination of turbo and intercooler to deliver 98kW (131.4hp) of power and 304Nm (30.7 kg-m) of torque. Also available with a 4-cylinder fuel-injected 2.4 litre gasoline engine putting out 105kW (140.8hp) of power and 205Nm (20.9kg-m) torque.

DRIVE TRAIN

Clean and easy shift changes are provided by the 5-speed manual transmission, and a braking systems load-sensing valve increases brake power to the rear when moving large loads, ensuring the NP300 HARDBODY makes light work of the toughest jobs.

Engaging 4WD locks the transfer case in a 50/50 torque split for maximum traction from front and rear axles. Auto locking hubs on the NISSAN NP300 HARDBODY higher grade 4WD models come standard, while the driver can manually lock the front wheel hubs on base and mid grade models to ensure that all four wheels are driven. Releasing the hubs when not required allows the wheels to turn free from the axle, improving fuel economy.

LIMITED SLIP DIFFERENTIAL

Limited Slip Differential on 4WD Diesel Base and Standard Grade models automatically transfers torque to the non-slipping drive wheel, allowing you to power out of virtually any situation. And unlike diff lock, it won't lead to expensive breakages due to negligence and can work at speed.



PROVEN MADE FOR BUSINESS

INSIDE AND OUT, THE NISSAN NP300 HARDBODY IS DESIGNED TO KEEP YOUR BUSINESS MOVING IN THE RIGHT DIRECTION

RUGGED EXTERIOR

The NISSAN NP300 HARDBODY's build quality and robustness extends to the exterior finishes too: developed and tested by firing diamond chips at the paintwork ensures maximum protection from flying gravel or stone. In addition, the all-round E-coat anti-rust treatment means that it can cope in extreme damp or humid conditions.

The pickup's masculine presence is enhanced in higher grade models with a roll bar, side steps, roof rail and a aluminium rear step bumper, while workhorse models come standard with a guard frame for extra cab protection when carrying loads. Add the reinforced load box, extra-strength tailgate chains, double-walled tailgate and rear side panels and sturdy cargo hooks, and it becomes clear that the NP300 HARDBODY really means business.

All diesel models feature a bonnet scoop that increases airflow into the turbo charger's intercooler, and hints at the formidable power beneath the hood. The long travel suspension with 15" steel wheels on the 2WD Single Cab, and 16" alloy wheels on all other models, allows for excellent ground clearance and the confidence to handle almost any African terrain.

VERSATILE INTERIOR

Comfort and functionality on all models are provided by tilt adjustable and power steering, and sliding front seats make getting in as easy as getting out.

A range of additional features are available depending on the model and grade: lockable glove box and door pocket with drinks holder, air-conditioner, radio with CD player, centre console with cup holders and power windows..

PROVEN PARTNERSHIP

The NISSAN NP300 HARDBODY remains the ideal choice of business partner in the commercial sector. Its dependable heritage has been built on well-proven mechanical underpinnings while fulfilling – and often going beyond – the essential functional systems requirements of today's business operations.

With a proud history of solid durability and reliability, together with strong after-sales support, skilled technicians and readily available parts, downtime is reduced to a minimum. This, together with the economical total cost of ownership, ensures your business stays firmly where it belongs – on the road.





NP300 HARDBODY

PROVEN IRONCLAD PROTECTION

THE NISSAN NP300 HARDBODY MAKES SAFETY AND SECURITY A PRIORITY



SAFETY SHIELD

In the commitment to "Real World Safety", Nissan pursues innovation as part of its Safety Shield concept. Based on the idea that cars should help protect people, advanced, proactive safety technologies help driver and passengers to avoid danger and injury in a wide range of circumstances.



SAFETY AND SECURITY

A steel reinforced chassis provides strength and absorbs the force from the front, while crease folds minimise impact in the cabin and side door intrusion bars add further protection to occupants in the event of an accident. Add driver and passenger airbags, in conjunction with the 3-point ELR seatbelt, and you are assured of the maximum protection all round.

For greater handling and control, the NP300 HARDBODY comes with fade resistant shock absorbers, ventilated front discs and a rugged double wishbone and independent suspension with telescopic shock absorbers, while the Anti-lock Braking System optimises braking performance.

With higher ground clearance and halogen headlamps for all-round visibility, you can be confident that both your people and your cargo are in safe hands.



The NISSAN NP300 HARDBODY makes security a priority. Standard in top of the range models are remote, keyless entry, central locking and child locks. And throughout the range, immobiliser, personally coded ignition key and fuel tank cap key are standard. For more detailed information on features, please see the specifications table.





PROVEN TAILORED TO YOUR REQUIREMENTS

ALL THE EXTRAS YOU NEED FOR THE PERFECT FIT

You know what you like. And with Nissan approved accessories you can customise your NP300 HARDBODY to perfectly fit your needs, whether it's functional style you're looking for or enhanced utilitarian capability.

Speak to your Nissan dealer for more information on the full range.

Some accessories are not compatible with all model grades.

Accessories available include:

- Tonneau Cover
- Towing Kit
- Canopy
- Loadbox rubberising
- Spare wheel locks
- Sports Bars
- Side Steps
- Bonnet and Headlamp guards
- Carpet sets
- Wraparound bushbar
- Nudgebar



COLOUR AND TRIM



Arctic White - QM1 (S)



Bright Silver - KY0 (M)



Thermal Gold - K32 (M)



Infinite Black - KH3 (S)*



Starling Blue - B16 (M)



Solid Red - AX6 (S)*



Claret Red - AY4 (M)

TRIM OPTIONS



PVC

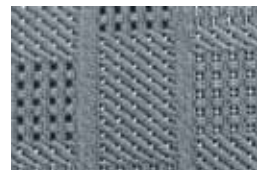

Woven fabric



Fabric with leather insert

*Special Order
(S) Solid
(M) Metallic

Nissan's commitment to quality

To provide all customers with a consistently high level of quality, Nissan applies the same standards worldwide, to ensure that all Nissan owners enjoy peace of mind for the lifespan of their vehicles. The approach is based on quality from the customer's perspective on three key elements. First, the expectation of a smooth driving experience with complete peace of mind. Second, the intangible appeal of a vehicle, its power to captivate and excite, with features that capture attention and imagination. Third, the level of attentiveness and service during the sales process, and long after the sale is concluded.

DIMENSIONS

SINGLE CAB

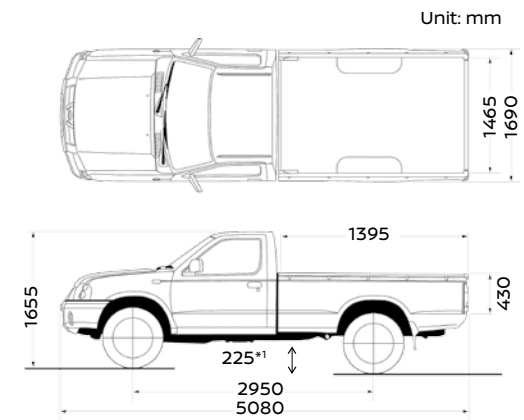

*1 2WD 205mm

DOUBLE CAB

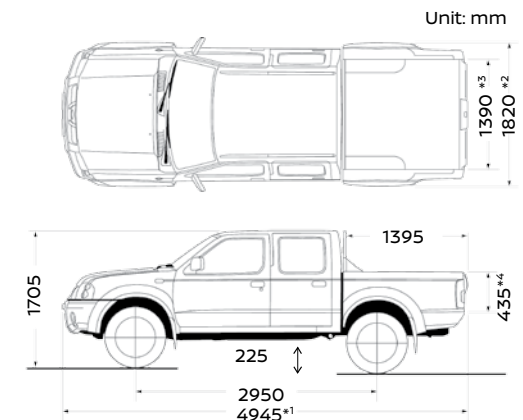

*1 STD Grade 5080mm

*2 STD Grade 1690mm

*3 STD Grade 1465mm

*4 STD Grade 430mm

PEACE OF MIND

OUR PROMISE TO YOU

At Nissan we keep our promises and take care of our family. Servicing and repairing your Nissan at an authorised Nissan dealership is the way to go. Our Nissan technicians are highly trained specialists that know your Nissan better than anyone. They will use Genuine Nissan Parts, Genuine Nissan Accessories to ensure quality, reliability and to keep your vehicle performing to optimum standards. Nissan aims to keep you and your vehicle on the road with total peace of mind - for as long as possible.

THIS IS A NISSAN AFTERSALES PROMISE.

NISSAN
AFTERSALES

OUR PROMISE. YOUR EXPERIENCE

Model Description	SINGLE CAB				DOUBLE CAB								
	SC 2WD 2.5i Diesel (Base)	SC 2WD 2.5i Diesel (Base with Aircon)	SC 2WD 2.4i Gasoline (Mid)	SC 4WD 2.5i Diesel (Mid)	DC 2WD 2.5i Diesel (Base)	DC 4WD 2.5i Diesel (Base)	DC 4WD 2.5i Diesel (Mid)	DC 4WD 2.5i Diesel (High)	DC 4WD 2.4i Gasoline (Mid with Safety Pack)	DC 4WD 2.5i Diesel (High)	DC 4WD 2.4i Gasoline (High)		
Drivetrain and fuel type	2WD Diesel	2WD Diesel	2WD Gasoline	4WD Diesel	2WD Diesel	4WD Diesel	4WD Diesel	4WD Diesel	4WD Diesel	4WD Gasoline	4WD Gasoline	4WD Diesel	4WD Gasoline
Grade	Standard	Standard	Standard	Standard	Standard	Standard	Standard	Standard	Standard	Standard	Standard	Higher Grade	Higher Grade
ENGINE													
Engine code	YD25	YD25	KA24	YD25	YD25	YD25	YD25	YD25	YD25	KA24	KA24	YD25	KA24
Displacement (cm3)	2488	2488	2389	2488	2488	2488	2488	2488	2488	2389	2389	2488	2389
Max power output (kw/rpm)	98/3600	98/3600	105/5600	98/3600	98/3600	98/3600	98/3600	98/3600	98/3600	105/5600	105/5600	98/3600	105/5600
Max torque (Nm/rpm)	304/2000	304/2000	205/3600	304/2000	304/2000	304/2000	304/2000	304/2000	304/2000	205/3600	205/3600	304/2000	205/3600
Type	Intercooler turbo diesel, 4-cyl. In-line, DOHC	Intercooler turbo diesel, 4-cyl. In-line, DOHC	Fuel injection, 4-cyl., DOHC	Intercooler turbo diesel, 4-cyl. In-line, DOHC	Intercooler turbo diesel, 4-cyl. In-line, DOHC	Intercooler turbo diesel, 4-cyl. In-line, DOHC	Intercooler turbo diesel, 4-cyl. In-line, DOHC	Intercooler turbo diesel, 4-cyl. In-line, DOHC	Intercooler turbo diesel, 4-cyl. In-line, DOHC	Fuel injection, 4-cyl., DOHC	Fuel injection, 4-cyl., DOHC	Intercooler turbo diesel, 4-cyl. In-line, DOHC	Fuel injection, 4-cyl., DOHC
Compression ratio	16.51	16.51	9.21	16.51	16.51	16.51	16.51	16.51	16.51	9.21	9.21	16.51	9.21
TRANSMISSION & DRIVETRAIN													
Transmission	5-Speed Manual	5-Speed Manual	5-Speed Manual	5-Speed Manual	5-Speed Manual	5-Speed Manual	5-Speed Manual	5-Speed Manual	5-Speed Manual	5-Speed Manual	5-Speed Manual	5-Speed Manual	5-Speed Manual
Gear ratios: 1st	3.58	3.58	3.59	3.58	3.58	3.58	3.58	3.58	3.58	3.59	3.59	3.58	3.59
Gear ratios: 2nd	2.08	2.08	2.25	2.08	2.08	2.08	2.08	2.08	2.08	2.25	2.25	2.08	2.25
Gear ratios: 3rd	1.36	1.36	1.42	1.36	1.36	1.36	1.36	1.36	1.36	1.42	1.42	1.36	1.42
Gear ratios: 4th	1.00	1.00	1.00	1.00	1.00	1.00	1.00	1.00	1.00	1.00	1.00	1.00	1.00
Gear ratios: 5th	0.76	0.76	0.82	0.76	0.76	0.76	0.76	0.76	0.76	0.82	0.82	0.76	0.82
Final drive Ratio	3.90	3.90	4.11	4.63	3.90	4.63	4.63	4.63	4.63	4.63	4.63	4.63	4.63
Limited Slip Differential (LSD)	N/A	N/A	N/A	Standard	N/A	Standard	Standard	Standard	Standard	N/A	N/A	N/A	N/A
HANDLING													
Brakes	Front	Disc	Disc	Disc	Disc	Disc	Disc	Disc	Disc	Disc	Disc	Disc	Disc
	Rear	Drum	Drum	Drum	Drum	Drum	Drum	Drum	Drum	Drum	Drum	Drum	Drum
	Anti-lock Braking System (ABS)	N/A	N/A	Standard	Standard	N/A	N/A	N/A	Standard	N/A	Standard	Standard	Standard
Suspension	Front	Independent double wishbone torsion bar with telescopic shock absorbers	Independent double wishbone torsion bar with telescopic shock absorbers	Independent double wishbone torsion bar with telescopic shock absorbers	Independent double wishbone torsion bar with telescopic shock absorbers	Independent double wishbone torsion bar with telescopic shock absorbers	Independent double wishbone torsion bar with telescopic shock absorbers	Independent double wishbone torsion bar with telescopic shock absorbers	Independent double wishbone torsion bar with telescopic shock absorbers	Independent double wishbone torsion bar with telescopic shock absorbers	Independent double wishbone torsion bar with telescopic shock absorbers	Independent double wishbone torsion bar with telescopic shock absorbers	Independent double wishbone torsion bar with telescopic shock absorbers
	Rear	Solid axle, leaf spring with telescopic shock absorbers	Solid axle, leaf spring with telescopic shock absorbers	Solid axle, leaf spring with telescopic shock absorbers	Solid axle, leaf spring with telescopic shock absorbers	Solid axle, leaf spring with telescopic shock absorbers	Solid axle, leaf spring with telescopic shock absorbers	Solid axle, leaf spring with telescopic shock absorbers	Solid axle, leaf spring with telescopic shock absorbers	Solid axle, leaf spring with telescopic shock absorbers	Solid axle, leaf spring with telescopic shock absorbers	Solid axle, leaf spring with telescopic shock absorbers	Solid axle, leaf spring with telescopic shock absorbers
Steering	Power assistance	Standard	Standard	Standard	Standard	Standard	Standard	Standard	Standard	Standard	Standard	Standard	Standard
	Height adjustment steering wheel (tit)	Standard	Standard	Standard	Standard	Standard	Standard	Standard	Standard	Standard	Standard	Standard	Standard
	Turning circle (tyres, m)	5.9	5.9	5.9	6.3	5.9	6.3	6.3	6.3	6.3	6.3	6.3	6.3
	Turning circle (body, m)	6.4	6.4	6.4	6.7	6.4	6.7	6.7	6.7	6.7	6.7	6.7	6.7
LOAD & DIMENSIONS													
Fuel tank capacity (litres)	75	75	75	75	75	75	75	75	75	75	75	75	75
Wheels	Tyre size	215R15	215R15	195R15	215R15	215R15	215R15	255R16	255R16	215R15	215R15	255R16	255R16
	Wheel size	15"	15"	15"	15"	15"	15"	16"	16"	15"	15"	16"	16"
	Wheel finish	Steel	Steel	Steel	Steel	Steel	Steel	Aluminium	Aluminium	Steel	Aluminium	Aluminium	Aluminium
Gross Vehicle Mass (kg)	2730	2730	2730	2740	2730	2740	2740	2740	2740	2730	2730	2740	2740
Gross Combination Mass (kg)	3730	3730	3730	5540	3730	5740	5740	5740	5740	4230	4230	5740	4240
Load & tow	Tare (kg)	1536	1536	1463	1717	1594	1813	1813	1813	1698	1698	1844	1727
	Load Capacity (kg) (GVM - Tare)	1194	1194	1267	1023	1136	927	927	927	1032	1032	896	1013
	Towing capacity (kg): Unbraked	750	750	750	750	750	750	750	750	750	750	750	750
	Towing capacity (kg): Trailer with overrun brake	1000	1000	1000	2800	1000	3000	3000	3000	3000	1800	1800	3000



Nissan's commitment to the environment: Nissan's environmental philosophy embraces people, vehicles and nature. In the pursuit of a sustainable mobile society, the Nissan Green Program aims to reduce the environmental impact of Nissan vehicles at every stage of the vehicle life cycle, while corporate activities address environmental challenges.

Model Description	SINGLE CAB				DOUBLE CAB								
	SC 2WD 2.5i Diesel (Base)	SC 2WD 2.5i Diesel (Base with Aircon)	SC 2WD 2.4i Gasoline (Mid)	SC 4WD 2.5i Diesel (Mid)	DC 2WD 2.5i Diesel (Base)	DC 4WD 2.5i Diesel (Base)	DC 4WD 2.5i Diesel (Mid)	DC 4WD 2.5i Diesel (High)	DC 4WD 2.4i Gasoline (Mid with Safety Pack)	DC 4WD 2.5i Diesel (High)	DC 4WD 2.4i Gasoline (High)		
LOAD & DIMENSIONS continued													
Dimensions	Ground clearance (mm)	205	205	195	205	195	205	225	225	205	205	225	225
	Overall Length (mm)	5170	5170	5010	5170	5080	5080	5080	5080	5080	5080	4945	4945
	Width (mm)	1690	1690	1690	1690	1690	1690	1690	1690	1690	1690	1820	1820
	Height (mm)	1645	1645	1645	1695	1655	1710	1705	1705	1705	1710	1710	1705
	Wheelbase (mm)	2950	2950	2950	2950	2950	2950	2950	2950	2950	2950	2950	2950
	Front track (mm)	1395	1395	1395	1395	1395	1395	1395	1395	1395	1395	1395	1395
	Rear track (mm)	1390	1390	1390	1390	1390	1390	1390	1390	1390	1390	1390	1390
	Loadbox length (mm)	2235	2235	1935	2235	1395	1395	1395	1395	1395	1395	1395	1395
	Loadbox width (mm)	1465	1465	1465	1465	1465	1465	1465	1465	1465	1465	1390	1390
Loadbox depth (mm)	430	430	430	430	430	430	430	430	430	430	435	435	
SAFETY & SECURITY													
Driver and passenger airbags	N/A	N/A	Standard	Standard	N/A	N/A	N/A	Standard	N/A	Standard	Standard	Standard	Standard
Seat belt (front)	3-point inertia reel	3-point inertia reel	3-point inertia reel	3-point inertia reel	3-point inertia reel	3-point inertia reel	3-point inertia reel	3-point inertia reel	3-point inertia reel	3-point inertia reel	3-point inertia reel	3-point inertia reel	3-point inertia reel
Side impact protection	Door guard bar	Door guard bar	Door guard bar	Door guard bar	Door guard bar	Door guard bar	Door guard bar	Door guard bar	Door guard bar	Door guard bar	Door guard bar	Door guard bar	Door guard bar
Headlamps	Halogen	Halogen	Halogen	Halogen	Halogen	Halogen	Halogen	Halogen	Halogen	Halogen	Halogen	Halogen	Halogen
Fog lamps	N/A	N/A	N/A	N/A	N/A	N/A	N/A	N/A	N/A	N/A	N/A	Standard	N/A
Central locking (remote control)	N/A	N/A	N/A	N/A	N/A	N/A	N/A	N/A	N/A	N/A	N/A	Standard	Standard
Anti-theft device (immobilizer)	N/A	N/A	N/A	N/A	N/A	N/A	N/A	N/A	N/A	N/A	N/A	Standard	N/A
INTERIOR COMFORT & CONVENIENCE													
Air conditioner	N/A	Standard	Standard	Standard	Standard	Standard	Standard	Standard	Standard	Standard	Standard	Standard	Standard
Power windows	N/A	N/A	N/A	N/A	N/A	N/A	N/A	N/A	N/A	N/A	N/A	Standard	Standard
Mirror	Black, manual adjustment	Black, manual adjustment	Black, manual adjustment	Black, manual adjustment	Black, manual adjustment	Black, manual adjustment	Black, manual adjustment	Black, manual adjustment	Black, manual adjustment	Black, manual adjustment	Black, manual adjustment	Chrome, power adjust	Chrome, power adjust
Storage	Lockable glove box	Standard	Standard	Standard	Standard	Standard	Standard	Standard	Standard	Standard	Standard	Standard	Standard
	Centre console	N/A	N/A	N/A	N/A	N/A	N/A	N/A	N/A	N/A	N/A	Standard	Standard
	Door pockets	Standard	Standard	Standard	Standard	Standard	Standard	Standard	Standard	Standard	Standard	Standard	Standard
Cup holders	N/A	N/A	N/A	N/A	N/A	N/A	N/A	N/A	N/A	N/A	N/A	Standard	Standard
Seat type (front seats)	Bench	Bench	Bench	Bench	Bench	Bench	Bench	Bench	Bench	Separate	Separate	Separate	Separate
Trim	Carpet floor cover	Standard	Standard	Standard	Standard	Standard	Standard	Standard	Standard	Standard	Standard	Standard	Standard
	Seat material	PVC	PVC	PVC	PVC	Woven Fabric	Woven Fabric	Woven Fabric	Woven Fabric	Woven fabric	Woven fabric	Leather and Fabric	Leather and Fabric
Radio with CD front loader	N/A	N/A	Standard	Standard	Standard	Standard	Standard	Standard	Standard	Standard	Standard	Standard	Standard
EXTERIOR BODY & STYLING													
Roll bar	N/A	N/A	N/A	N/A	N/A	N/A	N/A	N/A	N/A	N/A	N/A	Standard	Standard
Cab protector (guard frame)	Standard	Standard	Standard	Standard	Standard	Standard	Standard	Standard	Standard	Standard	Standard	N/A	N/A
Front bumper	Black	Black	Black	Black	Black	Black	Black	Black	Black	Black	Black	Body colour	Body colour
Rear bumper	N/A	N/A	Tube type, Black	Aluminium step type	Aluminium step type	Aluminium step type	Aluminium step type	Aluminium step type	Aluminium step type	Aluminium step type	Aluminium step type	Chrome step type	Chrome step type
Over fenders	N/A	N/A	N/A	Black	N/A	Black	Black	Black	Black	Black	Black	Body colour	Body colour
Mud guards/flaps front	Standard	Standard	Standard	Standard	Standard	Standard	Standard	Standard	Standard	N/A	Standard	Standard	Standard
Mud guards/flaps rear	Standard	Standard	Standard	Standard	Standard	Standard	Standard	Standard	Standard	Standard	Standard	Standard	Standard
Side Steps	N/A	N/A	N/A	N/A	N/A	N/A	N/A	N/A	N/A	Standard	Standard	N/A	Standard
Roof rack/roof rail	N/A	N/A	N/A	N/A	N/A	N/A	N/A	N/A	N/A	N/A	N/A	Standard	Standard
Load box hooks/fastener	Outer hooks	Outer hooks	Outer hooks	Outer hooks	Outer hooks	Outer hooks	Outer hooks	Outer hooks	Outer hooks	Outer hooks	Outer hooks	Smooth loadbed, inner hooks	Smooth loadbed, inner hooks

Every effort has been made to ensure that the content of this brochure is correct at the time of going to print (January 2017). This brochure has been produced featuring prototype or accessorized vehicles exhibited at motor shows and, in accordance with the company's policy of continuously improving its products, Nissan South Africa reserves the right to change the specification and the vehicles described and shown in this brochure at any time. Nissan dealers will be informed of any such modifications as quickly as possible. Please check with your local Nissan dealer to receive the most up-to-date information. Due to the limitations of the printing processes used, the colours shown in this brochure may differ slightly from the actual colours of the paint and interior trim materials used. All rights reserved. Reproduction in whole or part of this brochure without the written permission from Nissan is forbidden.