

“Dedicated to expanding the use of quality precast concrete”

NPCA QUALITY CONTROL MANUAL For Precast Concrete Plants

14th EDITION

November 02, 2020

Copyright 2020 by
National Precast Concrete Association (NPCA)
14th Edition, 2020
All rights reserved.

No part of this manual may be reproduced
in any form without permission in writing from
the National Precast Concrete Association.



NPCA
1320 City Center Dr
Suite 200
Carmel, Indiana 46032
800-366-7731 (phone)
317-571-0041 (fax)
www.precast.org

TABLE OF CONTENTS – 14th Edition

	Page
TABLE OF CONTENTS	i
FOREWARD.....	1
CHAPTER 1- GENERAL.....	6
1.1 PLANT QUALITY CONTROL PROCEDURES AND MANAGEMENT	
POLICIES	6
1.1.1 Plant Management and Personnel.....	6
1.1.2 Plant-Specific Quality Control Manual	7
1.1.3 QC Personnel Training	8
1.1.4 Continuous Improvement	8
1.1.5 Plant Requirements	9
1.2 PLANT SAFETY	10
1.2.1 Safety Program	10
1.2.2 Plant Requirements.....	10
1.3 DRAWINGS & MOCK-UPS.....	11
1.3.1 Drawings.....	11
1.3.1.1 Drawings for custom-made precast units.....	11
1.3.1.2 Drawings for standard precast units.....	11
1.3.2 Mock-ups.....	11
CHAPTER 2 – MATERIALS.....	13
2.0 BUY AMERICA.....	13
2.1 CONCRETE.....	13
2.1.1 Cement.....	13
2.1.2 Aggregates.....	14
2.1.2.1 Aggregate Gradation.....	14
2.1.2.2 Deleterious Substances.....	15
2.1.3 Lightweight Aggregate.....	17
2.1.4 Mixing Water	17
2.1.5 Chemical Admixtures.....	18
2.1.6 Supplementary Cementitious Materials	19
2.1.7 Plant Requirements.....	19
2.2 REINFORCEMENT.....	20
2.2.1 Reinforcing Bars.....	20
2.2.2 Reinforcing Wire.....	20
2.2.3 Bar Mats and Welded-Wire Reinforcement.....	21
2.2.4 Zinc or Epoxy-Coated Reinforcement.....	21
2.2.5 Plant Requirements.....	21
2.3 MISCELLANEOUS MATERIALS	22
2.3.1 Lifting Inserts and Lifting Hardware	22
2.3.2 Embedded Steel Shapes and Plates	23
2.3.3 Headed Studs and Deformed Anchor Studs.....	23
2.3.4 Manufacturing Accessories.....	23
2.3.5 Fiber Reinforcement.....	24
2.3.6 Joint Sealants and Connectors.....	24
2.3.7 Plant Requirements.....	25

CHAPTER 3 - CONCRETE	26
3.1 CONCRETE MIXES.....	26
3.1.1 Mix Proportions	26
3.1.1.1 Normal, Heavyweight, and Mass Concrete.....	26
3.1.1.2 Self-Consolidating Concrete.....	27
3.1.1.3 Dry-Cast / Zero Slump Concrete.....	27
3.1.1.4 Ultra High Performance Concrete (UHPC)	27
3.1.1.5 Mix Compatibility When Using Face Mix.....	28
3.1.2 Water-Cementitious Materials Ratio	28
3.1.3 Air Content	29
3.1.4 Compressive Strength.....	29
3.1.5 Admixtures	31
3.1.6 Plant Requirements.....	31
3.2 BATCHING AND MIXING	32
3.2.1 Requirements for Batching and Mixing Plants	32
3.2.2 Storage of Cement and Supplementary Cementitious Materials.....	32
3.2.3 Handling and Storage of Aggregates.....	33
3.2.4 Batching Equipment	33
3.2.5 Discharge of Materials into Mixers.....	34
3.2.6 Mixers	34
3.2.7 Mixing.....	35
3.2.8 Ready-Mixed Concrete.....	35
3.2.9 Plant Requirements.....	36
 CHAPTER 4 - PRODUCTION PRACTICES.....	 37
4.1 GENERAL.....	37
4.1.1 Plant Layout	37
4.1.2 Housekeeping	37
4.1.3 Forms and Forming Equipment	38
4.1.4 Handling Equipment.....	38
4.1.5 Machine-Made and/or Dry-Cast Products.....	39
4.1.6 Architectural Precast Concrete	40
4.1.6.1 Surface Finishes.....	40
4.1.6.1.1 As Cast.....	40
4.1.6.1.2 Exposed Aggregate Finish.....	41
4.1.6.1.3 Abrasive Blast Finish.....	41
4.1.6.1.4 Acid Etch Finish.....	41
4.1.6.1.5 Honed or Polished.....	42
4.1.6.1.6 Bush Hammered or tooling.....	42
4.1.6.1.7 Unformed Surfaces.....	42
4.1.6.1.8 Special Finishes.....	42
4.1.6.1.9 Architectural Finishes.....	43
4.1.6.1.10 Embedded Veneer.....	43
4.1.6.1.10.1 Stone Products.....	43
4.1.6.1.10.2 Clay Products.....	44
4.1.7 Plant Requirements.....	45
4.2 FABRICATION OF REINFORCEMENT AND BLOCKOUTS.....	46
4.2.1 Fabrication of Reinforcement.....	46
4.2.2 Welding of Reinforcing Steel	47
4.2.3 Welding of Steel Assemblies	47
4.2.4 Fabrication and Positioning of Blockouts	48

4.2.5	Plant Requirements	48
4.3	PRE-POUR OPERATIONS	49
4.3.1	Cleaning of Forms	49
4.3.2	Application of Form Release Agent	49
4.3.3	Positioning of Reinforcement	49
4.3.4	Positioning of Miscellaneous Embedded Items	51
4.3.5	Plant Requirements	51
4.4	CASTING CONCRETE	52
4.4.1	Transporting Concrete	52
4.4.2	Depositing Concrete into Forms	52
4.4.2.1	Placing Face Mix	53
4.4.2.2	Placing Back-up Mix	53
4.4.3	Consolidating Concrete	53
4.4.4	Finishing Unformed Surfaces	54
4.4.5	Secondary Pours	55
4.4.6	Hot Weather Precautions	56
4.4.7	Cold Weather Precautions	56
4.4.8	Plant Requirements	57
4.5	CURING CONCRETE	58
4.5.1	General	58
4.5.2	Curing by Moisture Retention	61
4.5.3	Curing with Heat and Moisture	62
4.5.4	Plant Requirements	63
4.6	STRIPPING PRODUCTS FROM FORMS	64
4.6.1	Minimum Strength Requirement	64
4.6.2	Product Damage During Stripping	64
4.6.3	Formed Surfaces	64
4.6.4	Post-Pour Inspection	65
4.6.5	Plant Requirements	66
4.7	REPAIRING CONCRETE	66
4.7.1	Repairing Minor Defects	66
4.7.2	Repairing Major Defects	67
4.7.3	Inspection of Repairs	67
4.7.4	Plant Requirements	67
4.8	MARKING, STORAGE, AND SHIPMENT OF PRODUCTS	68
4.8.1	Product Marking	68
4.8.2	Storage Areas	68
4.8.3	Storage of Products	68
4.8.4	Shipment of Products	69
4.8.5	Final Inspection	69
4.8.6	Plant Requirements	70
CHAPTER 5 - QUALITY CONTROL OPERATIONS		71
5.1	SUMMARY OF REQUIRED RECORDS	71
5.1.1	Raw Material Test Records	71
5.1.1.1	Independent Third Party Testing Laboratory	72
5.1.2	Work Orders and Product Drawings	72
5.1.3	Equipment Calibration Records	72
5.1.4	Aggregate and Concrete Test Records	73
5.1.5	Concrete Batching Reports	73
5.1.6	General Plant and Product Inspection Records	74

5.1.7	Plant Requirements	74
5.2	AGGREGATE TESTING	74
5.2.1	Aggregate Gradation	74
5.2.2	Moisture Content	75
5.2.2.1	Conventional and Dry-Cast Concrete	75
5.2.2.2	Self Consolidating Concrete	75
5.2.3	Plant Requirements	76
5.3	CONCRETE TESTING	76
5.3.1	Slump, Slump Flow, and Visual Stability Index	76
5.3.1.1	Slump	76
5.3.1.2	Slump Flow and Visual Stability Index	76
5.3.2	Temperature	77
5.3.3	Density (Unit Weight)	78
5.3.4	Air Content	78
5.3.5	Compressive Strength	80
5.3.5.1	Wet-Cast	80
5.3.5.2	Dry-Cast and/or Machine-Cast	80
5.3.5.3	SCC	80
5.3.5.4	Compressive Strength Specimens	81
5.3.5.5	Cores	81
5.3.5.6	Calibrated Impact Rebound Hammer Use	82
5.3.6	Plant Requirements	82
Table 5.3.6.a	83
Table 5.3.6.b	84
Table 5.3.6.c	85
CHAPTER 6 – SPECIAL REQUIREMENTS FOR SPECIFIC PRODUCTS		86
6.1	PRODUCTS MANUFACTURED ACCORDING TO ASTM INTERNATIONAL AND OTHER INDUSTRY STANDARDS	86
6.1.1	Product Manufacture	86
6.1.2	Proof of Conformance	86
6.1.3	Plant Requirements	87
6.2	CONCRETE PIPE REQUIREMENTS	87
6.2.1	Stormwater Concrete Pipe Requirements	87
6.2.1.1	Reinforcing Steel Inspection	87
6.2.1.2	Three-Edge Bearing Testing	87
6.2.1.3	Absorption Testing	88
6.2.1.4	Dimensional Checks	89
6.2.1.5	Joint Design and Testing	89
6.2.1.6	Watertightness Hydrostatic Testing	89
6.2.1.7	Watertightness Vacuum Testing	90
6.2.1.8	Gasket Quality Control	90
6.2.1.9	Plant Requirements	91
6.2.2	Sanitary Concrete Pipe Requirements	92
6.2.2.1	Reinforcing Steel Inspection	92
6.2.2.2	Three Edge Bearing Testing	92
6.2.2.3	Absorption Testing	93
6.2.2.4	Dimensional Checks	93
6.2.2.5	Joint Design and Testing	94
6.2.2.6	Watertightness Hydrostatic Testing	94
6.2.2.7	Watertightness Requirements	95

6.2.2.8	Off-Center Joint Proof of Design Testing.....	95
6.2.2.9	Joint Shear Proof of Design Testing.....	95
6.2.2.10	Confined Gasket Proof of Design Testing.....	95
6.2.2.11	Gasket Quality Control.....	96
6.2.2.12	Plant Requirements	97
6.3	ROUND MANHOLE REQUIREMENTS.....	97
6.3.1	Reinforcing Steel Inspection.....	97
6.3.2	Flat Slab Tops	98
6.3.3	Base, Riser and Cone Sections.....	98
6.3.3.1	Absorption Testing.....	98
6.3.3.2	Step Testing.....	99
6.3.3.3	Dimensional Checks	99
6.3.3.4	Sanitary Manhole Vacuum Testing	100
6.3.4	Joint Design	100
6.3.5	Gasket Quality Control	100
6.3.6	Plant Requirements.....	101
6.4	BOX CULVERT REQUIREMENTS	102
6.4.1	Absorption Testing	102
6.4.2	Joint Design	102
6.4.3	Pre-Pour Inspections.....	103
6.4.4	Dimensional Checks.....	103
6.4.5	Plant Requirements.....	103
6.5	SEPTIC TANK REQUIREMENTS.....	104
6.5.1	Structural Proof-of-Design	104
6.5.2	Watertightness Testing.....	104
6.5.3	Plant Requirements.....	105
6.6	GREASE INTERCEPTOR REQUIREMENTS	106
6.6.1	Structural Proof-of-Design	106
6.6.2	Watertightness Testing.....	106
6.6.3	Plant Requirements.....	107
APPENDIX A – STANDARDS CITED IN THE MANUAL AND REFERENCES		108
APPENDIX B – SAMPLE FORMS.....		119
NPCA PLANT CERTIFICATION TERMS AND CONDITIONS.....		142
NPCA PRECAST PLANT CERTIFICATION PROGRAM GRADING SCHEDULE.....		167
STANDARDIZED GRADING TABLES.....		173
EXAMPLE SELF-AUDIT REPORT.....		178

FOREWORD

Since its introduction in 1987 the NPCA Quality Control Manual for Precast Concrete Plants (also known as the NPCA QC Manual) has been a reliable quality management tool for the precast concrete industry. Its use in day-to-day plant operations enables management and production personnel to understand the requirements for manufacturing quality precast concrete. The NPCA QC Manual's practical information and adherence to accepted industry standards helps provide consistency to plant operations.

The National Precast Concrete Association and its Board of Directors strives for openness and impartiality in all aspects of the Plant Certification program. Through our quality assurance policy for the Plant Certification Program, we make every effort to ensure confidentiality of plant information and guard against any instances of conflict of interest in the conduct of the program.

One of the NPCA QC Manual's purposes is to define the fundamental requirements for a quality control program for precast concrete plants. The manual furnishes a framework for management decisions regarding equipment, procedures or personnel, which may be necessary to create a quality manufacturing environment.

Specifiers and users of precast concrete products are constantly seeking ways to identify high quality products. The NPCA Plant Certification Program is based on the premium quality control program outlined in this manual and is intended to assure that precast concrete plants are capable of manufacturing quality products.

The first edition of the NPCA QC Manual was published in 1987 in consultation with the members of the National Precast Concrete Association, and has been revised regularly since then. The fourteenth edition, February 2020 of the NPCA QC Manual was approved October 2019 by NPCA's Quality Assurance committee.

NPCA Quality Assurance Committee Members (2019 - 2020):

- Andrew Nashawaty, Scituate Concrete Pipe Corp. (Chairman)
- Wes Dees, Buildtech Sourcing LLC (Board Liaison)
- Matt Barbour, Barbour Concrete Co.
- Eric Barger, C.R. Barger & Sons Inc.
- Marcus Barnett, Hamilton Kent LLC
- Frank Bowen, Rosetta Hardscapes
- Jason Cross, Norwalk Concrete Industries
- Lynn Grimm, Lindsay Precast Inc
- Marvin Hanks, ParkUSA
- Hugh Martin, Oldcastle Infrastructure
- Matt McSweeney, Pennsylvania Department of Transportation
- Kelly Patterson, Columbia Precast Products LLC
- Mitchell Rainero, Permatile Concrete Products Co.
- Rusty Stever, Jensen Precast
- Jason Tucker, Texas Department of Transportation
- James Walker, Wilbert Vaults of Houston
- Todd Whittington, North Carolina Department of Transportation
- Drew Wieser, Wieser Concrete Products Inc.

INTRODUCTION

This manual outlines the basic requirements of precast concrete plants to assure the production of quality precast concrete products. Because the sizes of precast plants vary widely, hence the quality control facilities will vary as well. For example, a large plant is more likely to find that a well-equipped quality control laboratory is justified while a small plant is likely to have few quality control facilities onsite, and instead will use a commercial laboratory for testing. Both plants can produce quality products.

Information in the Commentary should be considered as explanatory. The purpose of the Commentary is to provide additional information and comments, not to add requirements.

Reference is made to many standards of the American Concrete Institute (ACI), American Association of State and Highway Transportation Officials (AASHTO), ASTM International (ASTM), Canadian Standards Association (CSA), the Precast Prestressed Concrete Institute (PCI), the Concrete Reinforcing Steel Institute (CRSI), and the American Welding Society (AWS). References are made using ASTM, plants that are subject to other standards referenced above may do so in complete equivalence throughout this manual. Where titles of standards are cited, the word "standard" many have been omitted. The most recent edition of these standards shall be used unless otherwise noted.

Technical terms used in this manual are defined in ACI 116, "Cement and Concrete Terminology." The technical terms in this manual are those generally used in the concrete industry in North America. There are many terms used only in certain regions and the authors have tried to avoid such terms. Readers are encouraged to write to NPCA if they feel that certain terms used in the manual should be defined.

OBJECTIVES

The main purpose of this manual is to outline the quality requirements for precast concrete plants. In cases where the project or product specifications imposed by an authority having jurisdiction are more stringent then they shall apply. If certain requirements are not specified in the design, the requirements outlined in this manual will apply.

The quality guidelines presented in this manual are based on industry consensus.

This manual defines a minimum satisfactory level of quality that the purchaser of precast concrete products can reasonably expect and that the precast concrete products manufacturer should provide.

In cases where specific project criteria are defined or specified, those requirements should prevail.

Quality control requires the attention and cooperation of all management and production personnel. An effective quality

control program typically requires management to make necessary changes in equipment, procedures or personnel to produce quality products.

MAJOR FACTORS IN QUALITY CONTROL

The single most important factor in quality control is management's commitment to produce quality products. Management must implement a quality control program that monitors quality and reports on conformance with requirements.

Qualified personnel are also required. Qualifications include a thorough knowledge of precast concrete and successful completion of NPCA's Production & Quality School Level I. Plants should maintain training records of all employees and key individuals should be qualified and trained.

Items that must be monitored and compared with standards include:

- a. Completeness of work orders and product drawings
- b. Quality of raw materials
- c. Quality of forms
- d. Fabrication and Positioning of Reinforcing Steel
- e. Concrete Quality
- f. Placement and consolidation of concrete
- g. Product dimensions
- h. Positioning of embedded items
- i. Curing of concrete
- j. Handling, storing and transporting products
- k. Recordkeeping

Another aspect of a successful QC program is the concept of continuous improvement. There is substantial benefit derived from documenting materials, procedures and/or products that do not conform to the applicable standards and using those documents to develop corrective action so that the nonconforming issues are reduced or eliminated in the future.

Quality of products is generally defined to be the consistent conformance with requirements. Quality control of precast concrete products requires much more than achieving the required concrete strength. Procedures for implementing the monitoring of the quality of products should be established by management and management should assure that the procedures are implemented. Qualified Production Quality School (PQS) courses in concrete technology and precast concrete production are offered by NPCA both online and in person.

PQS courses include:

PQS Level I – Basics –

Fundamentals of manufacturing quality precast concrete products and for those who are quality control auditors or aspire to be QC auditors

PQS Level II – Safety

A comprehensive, precast-specific course that will review the safety issues associated with the precast production process.

PQS Level II – Technical

Technical concepts such as Center of Mass and Structural Analysis will be presented in layman's terms so that reinforcement placement and proper lifting techniques can be better understood. Additional topics include blueprint reading, knowledge of specifications and much, much more.

PQS Level II – QA/QC

Covers Introduction – Quality, Water and Cement, Aggregate Properties, Durability and Transport Mechanisms, Concrete Testing, Hot and Cold Temperature Concreting, Variability, Troubleshooting & Root Cause Analysis, Mix Design and Developing and Maintaining a Quality Assurance Program for Certified Plants.

PQS Level II - Production

Topics include: concrete consolidation, proper application and use of release agents, reinforcement cages, curing, finishing, plant layout efficiency and lean manufacturing.

PQS Level III –Leadership

Topics include recruiting, hiring, training, communicating effectively, leading by example and celebrating success time management, goal setting, stress management and multi-cultural issues.

DISCLAIMERS

1. This manual does not claim or imply that it addresses all safety-related issues, if any, associated with its use. Manufacture of concrete products may involve the use of hazardous materials, operations and equipment. It is the responsibility of the plant personnel to determine appropriate safety, health and environmental practices and applicable regulatory requirements associated with the use of this manual and the manufacture of concrete products.
2. Use of this manual does not guarantee the proper function or performance of any product manufactured in accordance with the requirements contained in the manual. Routine conformance to the requirements of this manual should result in products of an acceptable quality according to current industry standards.
3. This publication is designed to provide accurate and authoritative information in regard to the subject matter covered; however, The National Precast Concrete Association acts a mediator without approving, disapproving or guaranteeing the validity or accuracy of any data, claim or opinion appearing herein. Information is provided and disseminated with the understanding that the National Precast Concrete Association is not engaged in rendering engineering, legal or any other professional services. If engineering, legal or other professional assistance is required, the services of a competent professional should be obtained. The National Precast Concrete Association does not assume and hereby disclaims liability to any person for any loss or damage caused by errors or omissions in the material contained herein, regardless of whether such errors result from negligence, accident or any other cause whatsoever.
4. The Building Energy Code and Building Fire Code are not referenced, nor do they apply to this program.
5. Proprietary products manufactured under Underwriters Laboratories (UL), U.S. Department of Defense (DoD) requirements are not subject to the requirements of the NPCA Plant Certification Program unless explicitly noted in contract documents.

STANDARD

COMMENTARY

_CHAPTER 1 - GENERAL

1.1 PLANT QUALITY CONTROL PROCEDURES AND MANAGEMENT POLICIES

1.1.1 Plant Management and Personnel

Plant management and personnel must be committed to the production of a consistently high-quality product. Understanding the company policies and a commitment to quality is essential. Frequent training reinforces this commitment. Also, personnel must be given the authority to enforce minimum Quality Control (QC) policy over production requirements. The organizational structure of a precast concrete plant shall include the implementation of a Quality Control Program, which is the responsibility of the general manager or chief executive officer.

Management must support and be dedicated to the production of quality products; otherwise, a Quality Control Program is unlikely to be successful. The plant QC Policy Statement should clearly state the management's commitment to producing high-quality products. This policy should be frequently discussed with employees and customers.

A person not directly involved in production and who is responsible to the general manager or chief executive officer administers quality control functions most effectively.

NPCA supports construction sustainability and advocates good stewardship of the environment. Producers are encouraged to use and document the use of reclaimed materials in manufactured products. Manufacturers seeking LEED (Leadership in Energy and Environmental Design) status for their projects must document the use of reclaimed materials.

The use of fly ash or granulated blast furnace slag as cementitious materials in concrete mix designs qualifies for the use of reclaimed materials. Reclaimed crushed concrete as an aggregate or as a surface finish is another use of a reclaimed material.

Note: Use of supplementary cementitious materials (SCMs) must comply with the appropriate ASTM and ACI test methods and standards.

STANDARD

COMMENTARY

1.1.2 Plant-Specific Quality Control Manual

The plant shall have a plant-specific QC manual that details the production and QC policies and procedures used by the plant. The manual shall be compiled in one notebook or binder for easy review by plant personnel or by an inspector. At a minimum, the manual shall include the requirements of this manual and the following sections:

1. Management QC policy statement
2. Company QC personnel organizational chart
3. Description of responsibilities for QC personnel
4. Description of training requirements for QC personnel, production staff, forklift operators and drivers.
5. Housekeeping plan
6. Product pre-pour, casting, post-pour and final inspection procedures
7. Plant curing procedures for all seasons
8. Minimum strength requirements for stripping and shipping product
9. Product repair policy and procedures
10. Product dimensional tolerances unless shown on product detail drawings and/or production documentation.
11. Form tolerances and maintenance policy
12. Mix design qualification and testing procedures
13. Raw material testing policy and procedures
14. Equipment calibration policy and procedures
15. Product performance test policy and procedures applicable to Chapter 6
16. Examples of all documentation and forms used by plant to record QC and production processes
17. Documentation of products manufactured under franchise or licensing agreements, including all design specifications and drawings.

A plant-specific quality control procedural manual should specifically define any attributes or practices unique to the plant. The plant specific manual should be reviewed a minimum of every twelve (12) months and updated as necessary.

Standard Operating Procedures (SOP) are a good way to define QC expectations.

A review process of all QC records should be incorporated into the plant's QC operations with the intent of continually improving operations and quality. This can include a periodic review of documentation indicating nonconforming materials, production procedures and/or products and establishing appropriate corrective action.

Products manufactured under the International Building Code (IBC) may require the Professional Engineer to be the Professional of Record (POR) for the certification of Special Inspections performed by the QC personnel of a producer seeking Precertified Plant status. The local building official can grant Precertification Status.

STANDARD

COMMENTARY

1.1.3 QC Personnel Training

1. Plant QC Inspectors and assigned backup inspectors shall hold current certificates of completion for:

a. NPCA Production and Quality School (PQS)

AND

b. American Concrete Institute (ACI) Concrete Field Testing Technician - Grade I.

Training records, including course outline, syllabus, test results and instructor qualifications shall be maintained on file at the plant for five years.

Because of the importance of properly trained personnel, training must remain current. Courses available for retraining every five years in the NPCA Production and Quality School (PQS) are:
PQS Level I
PQS Level I Refresher
PQS Level II QA/QC
PQS Level II Technical
PQS Level II Production
PQS Level II Safety
PQS Level III Leadership
Master Precaster

1.1.4 Continuous Improvement

The plant shall engage in continuous improvement activities each and every year and keep on file objective evidence of these activities in the form of documentation, policies and procedures, and visual example.

Continuous improvement activities shall be demonstrated in one or more of the following areas:

1. Production
2. Processes
3. Facilities
4. Operational

By definition, 'continuous improvement' is an ongoing effort to improve products, services or processes. Organizations efforts can seek incremental improvement over time or breakthrough improvement all at once.

Examples of Continuous Improvement Activities that qualify include, but are not limited to:
Production: Documented rearrangement of the production floor based on work flow or new product introduction. Process: A documented 5s or 6s activity in the plant.
Process: Batching Kaizen – using quality data (raw material data, mix data, plastic testing, compressive

STANDARD

COMMENTARY

testing) to drive mix optimization, cost reductions and process stability. Operational: A document control program for all plant documents. Facilities: Expansion or additions to production or office spaces improving efficiencies.

In order to be considered for continuous improvement points, the plant shall first, at a minimum do two of the following:

1. Actively participate in the Producer Portal (see Part 2.5 of the Plant Terms and Conditions);
2. Perform semi-annual self-audits using the self-audit tool available in the Producer Portal (see example Self-Audit report in Appendix B);
3. Educate plant staff beyond quality personnel (see Part 2.5 of the Plant Terms and Conditions).

As an Education example, the plant may register for a free NPCA one-hour webinar and train the entire plant over a lunch hour. Alternatively, the plant may also register for four free 15-minute Precast Learning Labs and use them as plant-wide toolbox talks while collecting signatures to prove attendance.

1.1.5 Plant Requirements:

1. Maintain a current copy of this NPCA Manual in ready access to inspectors and plant personnel.
2. Develop and periodically update a written plant-specific QC manual.
3. Maintain current copies of applicable ASTM International test methods and specifications on file.
4. Maintain files of project specifications and requirements.
5. Maintain employee training records in company files.
6. Designate and train a plant QC Inspector for each work shift, with an assigned individual designated as backup. The QC Inspector shall report to plant management and not directly to production personnel. In small plants, the designated QC Inspector can be included in daily production duties. A

designated QC Inspector shall be present any time the plant is in production.

7. Management or a designated representative shall hold QC meetings with QC and plant personnel a minimum of once every 6 months. A record of the minutes of these meetings and a list of attendees shall be kept in the plant files.
 - a. All NPCA Certified Plants shall discuss and maintain documentation tracking customer complaints and subsequent corrective actions taken by the plant related to product quality issues. Documentation shall be kept on file for a period of three years and made available to the auditor during each plant audit.

1.2 PLANT SAFETY

1.2.1 Safety Program

Each plant shall have an active plant safety program. The program shall include requirements of local, state, and federal laws, and in particular the requirements of the Occupational Safety and Health Administration (OSHA).

1.2.2 Plant Requirements:

1. Maintain a plant safety manual and documented safety program. A plant-specific safety manual developed in accordance with the NPCA Guide to Plant Safety, or similar manual shall be in ready access to inspectors and plant personnel.
2. Management or designated representative shall hold safety meetings with plant personnel a minimum of once every month. A record of the minutes of these meetings and a list of attendees shall be kept in the plant files.

1.3 DRAWINGS & MOCK-UPS

1.3.1. Drawings

Erection drawings shall include elevations, dimensions, connection details, exposure of each piece...

1.3.1.1. Drawings for custom-made precast units

The drawings for custom-made precast concrete units shall be shop drawings furnished by the precast concrete producer for approval by the customer. These drawings shall show complete design, installation, and construction information in such detail as to enable the customer to determine the adequacy of the proposed units for the intended purpose. Details of steel reinforcement size and placement as well as supporting design calculations, if appropriate, shall be included. The drawings shall also include exposure of each piece, include all details for reveals, finish or finishes, The precast concrete units shall be produced in accordance with the approved drawings.

1.3.1.2. Drawings for standard precast units

The drawings for standard precast concrete units shall be shop drawings furnished by the precast concrete producer for approval by the customer. These drawings shall demonstrate that the applicable industry design standards have been met. Installation and construction information shall be included on shop drawings upon request. Details of steel reinforcement size and placement as well as supporting design calculations, if appropriate, shall be included. The precast concrete units shall be produced in accordance with the approved drawings. Drawings shall indicate assumptions used in the design of standard units. It is the responsibility of the project's engineer-of-record to verify that the design assumptions are suitable for the proposed application.

1.3.2 Mock-ups

Prior to production of architectural precast units, the plant provide representative samples for evaluation. At a minimum, a 12 inch x 12 inch sample shall be submitted to show representation of color and texture of the finished surface. One sample for each different finish (including if the back side of the precast is to be exposed) should be submitted if more than one finish is being specified.

Any change in materials or mix proportions requires new samples be evaluated prior to change in production.

Mock-Ups

Following approval of a representative sample and if required by project specifications, a complete or a portion of a full scale production unit is usually produced. The mock-up unit (s) will establish the range of acceptability with respect to color and texture variations, uniformity of air

STANDARD

COMMENTARY

void distribution, surface defects, and overall appearance.

Mock-up unit (s) or panels etc should be viewed at a distance that equals their distance on the structure; however this distance is not less than 20 feet. Mock-ups are usually approved and signed off by the architect or a designated representative and are stored at the plant and used as a comparison to production units. If requested, a mock-up may be shipped to the jobsite for comparison to the units installed on the project.

CHAPTER 2 – MATERIALS

2.0 BUY AMERICA PROVISIONS

Plants shall abide by all Buy America Provisions as specified by federal, state and/or local requirements. Plants shall obtain and keep on file certificates of compliance as noted in the applicable sections of this chapter. Plants shall obtain and keep on file certificates of origin for all raw materials as defined by the applicable Buy America Provision (reinforcing steel tie wire and other raw materials may be exempted only as expressly noted in the individual project specification, by federal, state or municipal mandate). Materials not produced domestically shall be segregated from those materials approved for use in Buy America products.

2.1 CONCRETE

2.1.1 Cement

Cement shall conform to to the requirements of ASTM C150, “Standard Specification for Portland Cement.” ~~or shall be Type IS—portland blast-furnace slag cement or Type IP—portland-pozzolan cement conforming to the requirements of~~ ASTM C595, “Standard Specification for Blended Hydraulic Cement.” or ~~shall conform to the requirements of~~ ASTM C1157 “Standard Performance Specification for Hydraulic Cement”. Evidence of conformance shall be a certified mill test report for each shipment or lot of cement.

Five Six base types of Pportland cement are specified in ASTM C150 but only three types are commonly used:

Type I - This cement is most commonly used available in most of North America and is intended for use in general concrete construction.

Type II - Moderate heat of hydration and Provides moderate sulfate resistance cement and is used extensively where soils or groundwater are moderately high in sulfates and in massive construction.

Type II(MH) – Provides moderate sulfate resistance and moderate heat of hydration and is a newer cement type that may not be available in all areas.

STANDARD

COMMENTARY

In architectural concrete, it is especially important to use cement of the same type and brand and obtained from the same mill and the same lot throughout the project to minimize color variation.

2.1.2 Aggregates

Fine and Coarse aggregates shall conform to the requirements of ASTM C33, "Standard Specification for Concrete Aggregates." Evidence of compliance shall be a certification from the supplier that the aggregate meets the ASTM C33 standard. In addition, aggregates shall be evaluated per ASTM C1778, "Standard Guide for Reducing Risk of Deleterious Alkali-aggregate reaction on Concrete" and documentation maintained on file at the plant for potential deleterious expansion due to alkali reactivity, unless the aggregates are received from a state department of transportation approved source and are known not to be reactive.

2.1.2.1 Aggregate Gradation

Fine aggregate shall be tested for gradation for each 1,500 tons (1,350 metric tons) of fine aggregate used, or once a month, whichever occurs first.

Type III - High early strength cement is used where rapid strength gain is needed.

Type V – Provides high sulfate resistance and is specified where high sulfate resistance is needed.

The remaining cement type is other two types are not readily available in most parts of the country. Type IV, low heat of hydration cement, is typically manufactured only for large dam construction. Type V, sulfate-resisting cement is specified where high sulfate resistance is needed.

When using blended cements, trial batches should be tested to ensure adequate strength is reached prior to stripping the product.

Uniformity of aggregate gradation is needed to maintain uniformity of concrete quality. A reduction in the amount of material passing the No. 30 (0.600 mm) and No. 50 (0.300 mm) sieves may tend to cause excessive bleeding so it may be advisable to blend in a fine masonry sand, increase the sand content in the mix (and reduce the coarse aggregate content), or increase the amount of cement in the mix. It may

STANDARD

Coarse aggregates shall be tested for gradation for each 2,000 tons (1,800 metric tons) of coarse aggregate used, or once a month, whichever occurs first.

The maximum size of coarse aggregate shall be as large as practical, but shall not exceed one-fifth of the minimum thickness of the precast concrete product, or three-fourths of the clear cover between reinforcement and the surface of the product. Larger maximum sizes of aggregate may be used if evidence shows that satisfactory concrete products can be produced.

2.1.2.2 Deleterious Substances

Fine and coarse aggregate from all suppliers shall be tested for deleterious substances initially, then annually thereafter and whenever the aggregate is suspected of contamination. Current test reports shall be dated not more than one year at the end of the month from the date of the last test or certification. Deleterious substance testing must conform to the requirements and limits stated in ASTM C33 "Standard Specification for Concrete Aggregates."

COMMENTARY

be necessary to blend two coarse aggregate sizes to achieve an optimal gradation that is satisfactory for the concrete mix being produced. An increase in fines may permit a reduction in the sand content in the mix.

Aggregate suppliers may offer to perform testing at no charge. If the aggregate supplier will not perform the required testing, the plant may perform the testing in-house (for gradation and organic impurities) or may employ a local testing laboratory.

Sands with organic impurities may result in erratic setting times of the concrete. In addition, some organic impurities such as roots and vegetable or wood fibers may affect the appearance and durability of exposed concrete products. Sands that fail to meet the organic impurity tests should not be used in precast concrete products.

Most specifications indicate that sand must be free of organic impurities. The test is relatively simple to perform in the plant. If there are no organic impurities, the results are positive and no additional tests are needed, but if the results indicate possible contamination of the aggregates, strength tests of mortar cubes made with the sand in question should be

STANDARD

COMMENTARY

made and tested in compression.

Companion cubes made of sand containing no organic impurities should be made and tested in compression at the same age as those made with the sand in question. If the strength of the questionable cubes is at least 90% of the strength of the companion cubes, the sand may be used for making concrete. It should be noted that some organic impurities will affect setting time of concrete, but the organic impurities test does not give an indication of setting time.

Additional aggregate test methods not listed in this manual may be necessary if contamination is suspected.

If possible, coarse and fine aggregates should be obtained from sources approved for use in highway pavements by state departments of transportation. Otherwise it will be necessary to obtain test reports that show that the aggregates not only conform to ASTM C33 but also are non-reactive and are stable.

Aggregate suppliers may offer to perform testing at no charge. If the aggregate supplier will not perform the required testing, the plant may perform the testing in-house (for gradation) or

STANDARD

COMMENTARY

may employ a local testing laboratory.

2.1.3 Lightweight Aggregate

Lightweight aggregates shall conform to the requirements of ASTM C330, "Standard Specification for Lightweight Aggregates for Structural Concrete." Tests for lightweight aggregate gradation and unit weight shall be performed initially and for each 200 cubic yards (150 cubic meters) of lightweight aggregate supplied, or once a month, whichever occurs first. Test records shall be maintained at the plant.

To assure a uniform quality of lightweight concrete, the gradation and dry-loose unit weight of the lightweight aggregates should be consistent. Variation in either the gradation or the density generally requires adjustments to the mix proportions in order that uniform concrete will be produced. Control of aggregate moisture can be even more important with lightweight aggregates. It is best practice to store lightweight aggregate in a wet, saturated condition and adjust the mix water for excess water on the aggregate.

2.1.4 Mixing Water

Water used in mixing concrete shall conform to the requirements of ASTM C1602, "Standard Specification for Mixing Water used in the Production of Hydraulic Cement Concrete" and shall be free from deleterious amounts of oils, acids, alkalis, salts, organic material or other substances that may adversely affect the properties of fresh or hardened concrete.

Mix water shall not contain iron or iron oxides that may cause staining when using white cement.

Water from municipal water supply systems or from other sources approved for drinking can be used for making concrete. Seawater, brackish water, or other water with high chloride contents should not be used in reinforced concrete. Impure water can affect setting time and algae in water can entrain additional air.

ASTM C1602 covers the compositional and performance requirements for mixing water used in hydraulic cement concrete.

STANDARD

COMMENTARY

2.1.5 Chemical Admixtures

Admixtures shall conform to the applicable specification as follows:

<u>Admixture Type</u>	<u>Specification Title</u>	<u>Specification Designation</u>	
Air entrainment	"Standard Specification for Air-Entraining Admixtures for Concrete"	ASTM C260	<i>Chemical admixtures may be helpful or may be needed to improve the properties of fresh or hardened concrete. Such admixtures include those used to entrain air, retard or accelerate set, reduce water content, reduce permeability, make the concrete more workable, reduce steel corrosion or to add color to the concrete.</i>
Water reducers, retarders, accelerators, high-range water reducers, specific performance admixtures (Viscosity / Rheology Modifying Admixtures)	"Standard Specification for Chemical Admixtures for Concrete"	ASTM C494	<i>Chemical admixtures may be helpful or may be needed to improve the properties of fresh or hardened concrete. Such admixtures include those used to entrain air, retard or accelerate set, reduce water content, reduce permeability, make the concrete more workable, reduce steel corrosion or to add color to the concrete.</i>
	"Standard Specification for Chemical Admixtures for Use in Producing Flowing Concrete"*	ASTM C1017	
Coloring	"Standard Specification for Pigments for Integrally Colored Concrete"	ASTM C979	
Corrosion Inhibitors	"Standard Test Method for Determining the Effects of Chemical Admixtures on the Corrosion of Embedded Steel Reinforcement in Concrete Exposed to Chloride Environments"	ASTM G109	<i>Corrosion Inhibitors are evaluated through test method outlined in ASTM G109. Calcium chloride or admixtures containing high chloride concentrations are not recommended for use in precast concrete products that contain reinforcement or other metals.</i>

Admixtures shall be products from manufacturers from whom test data are available to establish their effects on concrete and compatibility with other materials in the mix.

STANDARD

COMMENTARY

2.1.6 Supplementary Cementitious Materials

Supplementary cementitious materials (SCMs) shall conform to the applicable specifications shown below. Evidence of conformance shall be a certified mill test report for each shipment or lot of SCMs.

When using SCMs and depending on the cement replacement levels, certain SCMs may delay the initial strength gain of the concrete. Proper measures should be taken to ensure product has achieved adequate strength prior to stripping and shipping.

Pozzolans

“Standard Specification for Coal Fly Ash and Raw or Calcinated

ASTM C618

Natural Pozzolan for Use in Concrete”

Standard types fly ash:

- Class C fly ash
- Class F fly ash

Variations to standard types fly ash commonly used:

- MFA – Modified fly ash
- UFFA – Ultra-fine fly ash

GBA – Ground Bottom ash

Silica Fume

“Standard Specification for Silica Fume Used in Cementitious Mixtures”

ASTM C1240

Slag **Cement**

“Standard Specification for **Ground Granulated Blast-Furnace Slag Cement** for use in Concrete and Mortars”

ASTM C989

Metakaolin

“Standard Test Methods for Sampling and Testing Fly Ash or Natural Pozzolans for Use in Portland-Cement Concrete”

2.1.7 Plant Requirements:

1. The following documentation shall be maintained current in the plant records:
 - Cement and supplementary cementitious material certified mill test reports or certificates for each shipment or lot,
 - Aggregate supplier and test reports,

Unless records of aggregate and concrete tests are identified in such a manner that make it possible to determine which products were made with the tested materials, they

STANDARD

COMMENTARY

- Mix water potability test reports or other test records indicating the acceptability of the mix water. Current test reports shall be dated not more than one year at the end of the month from the date of the last test or certification. Municipal water supply is acceptable without testing.
- Chemical admixture and other additive certified test reports or certifications shall be dated not more than one year at the end of the month from the date of the last test or certification.

are not very useful. A simple orderly method of relating such records to specific products can make the test reports valuable. Placing the cast date on the product is usually sufficient to track the product to the daily quality control records and raw materials.

2. Documentation of conformance to ASTM C33 (excluding gradation testing) and test reports indicating that the aggregates are non-reactive and stable shall be maintained for each aggregate source used. Such documentation shall be obtained from the supplier, an appropriate state agency, or a testing laboratory engaged by the plant, a minimum of once per year for each material used. Current test reports shall be dated not more than one year at the end of the month from the date of the last test or certification. The maximum aggregate size shall be proper for the products being cast.

Documentation showing that the aggregate source is department of transportation approved is an acceptable means of documenting aggregates are non-reactive and stable.

Tests for aggregate gradation and deleterious substances shall be performed at the minimum frequency. Lightweight aggregate shall be tested for gradation and unit weight at the minimum frequency.

3. Records of incoming raw materials and plant materials tests shall be kept current and on file for a minimum of three (3) years.
4. The cement type, supplementary cementitious materials, and chemical admixtures shall be appropriate for the intended use.

2.2 REINFORCEMENT

2.2.1 Reinforcing Bars

Steel reinforcing bars shall conform to the specification required in the design:

“Standard Specification for Deformed and Plain Billet – Steel Bars for Concrete Reinforcement” ASTM A615

“Standard Specification for Low-Alloy Steel Deformed and Plain Bars for Concrete Reinforcement” ASTM A706

Bars conforming to ASTM A706 have a low carbon equivalency and can be readily welded. However, they are not commonly stocked by suppliers and

STANDARD

COMMENTARY

Other bars may be used for specific purposes if permitted by the design or project requirements.

generally rather sizeable minimum quantities must be ordered.

Reinforcing bar suppliers shall furnish mill certificates for each shipment. Records of incoming reinforcing steel mill certificates shall be kept current and on file for a minimum of three (3) years.

2.2.2 Reinforcing Wire

Reinforcing steel wire shall conform to the applicable specifications:

Section 2.2.2 permits the use of wire other than the types listed, but it is recommended that other types of wire not be used unless specifically specified.

“Standard Specification for Steel Wire, and Welded Wire Reinforcement, Plain and Deformed, for Concrete” ASTM A1064

Other wire may be used for specific purposes if permitted by the design or project requirements. Reinforcing wire suppliers shall furnish mill certificates for each shipment. Records of incoming reinforcing wire mill certificates shall be kept current and on file for a minimum of three (3) years.

2.2.3 ~~Bar Mats and~~ Welded-Wire Reinforcement

~~Steel bar mats and~~ Welded wire reinforcement shall conform to the specification required in the design:

Welded wire reinforcement delivered in rolls should be used in circular or curved products, unless the reinforcement is first straightened. Otherwise it is quite difficult to position and support the reinforcement within straight-walled product.

~~“Standard Specification for Welded Deformed Steel Bar Mats for Concrete Reinforcement” ASTM A184~~

“Standard Specification for Steel Wire, and Welded Wire Reinforcement, Plain and Deformed, for Concrete” ASTM A1064

Suppliers of bar mats and welded wire reinforcement shall furnish mill certificates with each shipment. Records of incoming reinforcing steel mill certificates shall be kept current and on file for a minimum of three (3) years.

2.2.4 Zinc or Epoxy-Coated Reinforcement

Where required by the design, reinforcement shall be galvanized in accordance with ASTM A767, “Standard Specification for Zinc-Coated (Galvanized) Steel Bars for Concrete Reinforcement,” or epoxy coated in accordance with ASTM A775, “Specification for Epoxy-Coated Reinforcing Steel Bars,” ASTM A884, “Standard Specification for Epoxy-Coated

Currently there are no ASTM Standards for zinc-coated welded wire reinforcement. However, the product is available and may be used in precast

STANDARD

COMMENTARY

Steel Wire and Welded Wired Fabric for Reinforcement,” or ASTM A934, “Standard Specification for Epoxy-Coated Prefabricated Steel Reinforcing Bars.” Epoxy-coated reinforcing steel shall be supplied by a CRSI-certified applicator and accompanied by a certification or certificate of compliance. Epoxy-coated reinforcement shall be stored and handled in such a manner as to minimize damage to the epoxy coating.

concrete products when specified.

2.2.5 Plant Requirements:

1. Mill certificates and certificates of conformance shall be maintained current for all reinforcement including reinforcing bars, reinforcing wire, bar mats, welded wire reinforcement and coated reinforcing.
2. The plant QC Inspector shall crosscheck that certificates are on file for all reinforcing heat numbers being used or stored.
3. Certificates shall be maintained in the plant records for a minimum of three (3) years.

2.3 MISCELLANEOUS MATERIALS

2.3.1 Lifting Inserts and Lifting Hardware

Lifting inserts used in precast concrete products shall be verified for capacity and shall have an adequate factor of safety for lifting and handling products taking into account the various forces acting on the device including form release suction, impact, and various positions of the product during handling. The capacity of commercial lifting devices shall be marked on the devices or posted in production areas.

Other applicable codes and standards are ANSI A10.9 and ASTM C857, C890 and C913.

Lifting inserts which are embedded or otherwise attached to precast concrete members shall be capable of supporting at least four times the maximum intended load applied or transmitted to them, as required in OSHA 29 CFR 1926.704 (c).

Lifting hardware such as slings, lift bars, chains, hooks, etc., shall be verified for capacity and shall have an adequate factor of safety for lifting and handling products.

Lifting hardware shall be capable of supporting at least five times the maximum intended load applied or transmitted to the lifting hardware, as required in OSHA 29 CFR 1926.704 (d).

STANDARD

COMMENTARY

2.3.2 Embedded Steel Shapes and Plates

Steel shapes and plates that are to be embedded in precast concrete shall conform to the requirements of ASTM A36, "Standard Specification for Carbon Structural Steel." Other types of steel shapes and plates may be used if the requirements are specified in the design. Applicable mill test reports shall be maintained at the plant for each shipment received.

If embedded steel shapes or plates will be exposed to moisture or other corrosive environments, they should be galvanized, stainless steel, or coated with suitable rust-inhibiting materials.

2.3.3 Headed Studs and Deformed Anchor Studs

Studs to be welded to steel shapes or plates for concrete anchors shall conform to the requirements of ASTM A108, "Standard Specification for Steel Bars, Carbon, Cold-finished, Standard Quality," unless higher strengths are required by design.

Proper use of stud welding equipment is necessary to assure adequately strong welds. Studs should be able to withstand 30 degree bend test without failure. Test bending of studs should be made on the first two studs at the start of each welding production period. If welds fail the 30 degree bend test, adjustments should be made to the settings on the generator, timer and stud gun. If adjustments fail to produce suitable welds, the equipment should not be used until acceptable welds can be produced consistently.

2.3.4 Manufacturing Accessories

Spacers for reinforcement, inserts, form ties, and similar accessories incidental to the manufacture of precast concrete products shall be adequate for their intended purposes and shall result in minimum marring of the concrete surfaces. Use of accessories of dissimilar metals shall be avoided, unless surfaces of the manufacturing accessories are permanently protected against corrosion.

Corrosion caused by metal bar chairs is unsightly and for certain products might be objectionable. More serious, however, is galvanic corrosion caused by dissimilar metals. For example, aluminum conduit embedded in reinforced concrete is likely to corrode, particularly if it is in contact with reinforcing steel or if there are chlorides in the concrete.

Coated tie wires shall be used with epoxy-coated reinforcement.

STANDARD

COMMENTARY

2.3.5 Fiber Reinforcement

Data shall be provided to show conclusively that the type, brand, quality and quantity of fibers to be included in the concrete mix are not detrimental to the concrete or to the precast concrete product.

Fiber reinforced concrete shall conform to ASTM C1116, "Standard Specification for Fiber-Reinforced Concrete and Shotcrete," (Type I or Type III).

Only two types of fibers are typically used: synthetic and steel fibers.

Synthetic fibers are typically used in concrete to reduce plastic shrinkage cracks and / or to improve impact resistance. They can help to reduce chipping of products that are stripped. Synthetic fibers do not increase the compressive strength of concrete. Synthetic fibers are characterized as micro or macro fibers. Micro fibers are typically used to reduce plastic shrinkage cracks and improve impact resistance. Macro fibers can be used in some situations as secondary reinforcement.

Steel and some synthetic fibers increase the flexural strength of concrete, but the concrete mix should be designed so that the mix is workable. It is important to follow manufacturer's instructions on introducing the fibers into the mix and on safety precautions.

2.3.6 Joint Sealants and Connectors

Certificates of Conformance shall be obtained from all suppliers and maintained on file for each type of joint sealant, and pipe-to-structure connector used by the plant, a minimum of once per year.

Joint sealants typically must conform to ASTM C990. Pipe-to-structure connectors typically must conform to ASTM C923 or C1478.

STANDARD

COMMENTARY

Refer to sections 6.2.6 for pipe joint gasket requirements and 6.3.5. for manhole joint gasket requirements.

2.3.7 Plant Requirements:

1. Commercial lifting inserts and hardware shall be certified and posted for maximum capacity. As a minimum, inspect all lifting apparatus and maintain inspection records in the plant files. Current inspection reports shall be dated not more than one year at the end of the month from the date of the last test or certification.
2. Non-commercial lifting inserts and hardware shall be proof-tested by a certified testing lab for the rated working load limit (WLL). A factor of safety in compliance with the requirements of the OSHA regulation 29 CFR 1926.704 (c & d) shall be met.
3. Embedded steel shall be protected from corrosion when necessary and dissimilar metals shall not be in contact.
4. Accessories and fiber reinforcement shall be appropriate for their intended use.

OSHA requirements for lifting devices and apparatus are documented in "Code of Federal Regulations" Title 29 Part 1926.

More frequent inspection of lifting devices may be required to meet local safety requirements or for devices under severe working conditions. Personnel using lifting devices and apparatus are expected to visually inspect each device prior to use.

CHAPTER 3 - CONCRETE

3.1 CONCRETE MIXES

3.1.1 Mix Proportions

Concrete mixes shall be proportioned in accordance with ACI 211.1, "Practice for Selecting Proportions for Normal, Heavyweight, and Mass Concrete," ACI 211.2, "Practice for Selecting Proportions for Structural Lightweight Concrete," ACI 211.3, "Practice for Selecting Proportions for No-Slump Concrete," or ACI 237 "Self-Consolidating Concrete." (SCC) Mix proportions shall be determined by a commercial laboratory, project specifications, or by qualified precast plant personnel for each combination of aggregates, cement, water, and admixtures. Mix proportions shall be appropriately modified for changes in source of materials, gradation of aggregates, moisture content of aggregates, cement content, or admixtures.

Concrete should be proportioned so that it will (1) be adequately workable, (2) have the required properties after it hardens (durability, strength, impermeability, acceptable volume change characteristics, etc.), and (3) be economical. To achieve the required properties after hardening requires an adequately low water-cementitious materials ratio and proper air entrainment. Economy of raw materials is best achieved by using the maximum practical size of coarse aggregate, the optimum fine-to-coarse aggregate ratio, and the stiffest mix that is practical while maintaining the correct water-cementitious material ratio and air content.

3.1.1.1 Normal, Heavyweight, and Mass Concrete

Plants using normal, heavyweight, and mass concrete shall include specific quality control procedures in their plant-specific QC manual, as discussed in 1.1.2. At a minimum, detailed written procedures shall address the steps necessary for initial mix qualification and subsequent daily quality control operations.

Initial mix qualifications shall be documented in the plant files. Documentation shall include trial batching and in-depth concrete testing. Mix qualification procedures shall include the establishment of acceptable tolerance ranges for test results of daily quality control testing (See example Mix Qualification Form in appendix B.)

STANDARD

COMMENTARY

Subsequent daily quality control operations must follow the daily quality control testing acceptance criteria established during the initial mix qualification (see Section 5.2 and 5.3).

3.1.1.2 Self-Consolidating Concrete

Plants using self-consolidating concrete (SCC) shall include SCC-specific quality control procedures in their plant-specific QC manual, as discussed in 1.1.2. At a minimum, detailed written procedures shall address the steps necessary for initial mix qualification and subsequent daily quality control operations.

Initial mix qualifications shall be documented in the plant files. Documentation shall include trial batching and in-depth concrete testing. Mix qualification procedures shall include the establishment of acceptable tolerance ranges for test results of daily quality control testing (See example SCC Mix Qualification Form in appendix B.)

Subsequent daily quality control operations must follow the daily quality control testing acceptance criteria established during the initial mix qualification (see Section 5.2 and 5.3).

3.1.1.3 Dry-Cast / Zero Slump Concrete

Plants using dry-cast / zero slump concrete shall include specific quality control procedures in their plant-specific QC manual, as discussed in 1.1.2. At a minimum, detailed written procedures shall address the steps necessary for initial mix qualification and subsequent daily quality control operations.

Initial mix qualifications shall be documented in the plant files. Documentation shall, include trial batching and in-depth concrete testing. Mix qualification procedures shall include the establishment of acceptable tolerance ranges for test results of daily quality control testing.

Subsequent daily quality control operations must follow the daily quality control testing acceptance criteria established during the initial mix qualification.

3.1.1.4 Ultra High Performance Concrete (UHPC)

Plants using ultra high performance concrete shall include specific quality control procedures in their plant-specific QC manual, as discussed in 1.1.2. At a minimum, detailed written

The plant should consult with their admixture supplier in developing appropriate quality control operations. The plant may also consider consulting the "NPCA Guide to Implementing SCC", ASTM Standards, ACI and other recognized national standards and guides for the use of Self-Consolidating Concrete. Daily quality control testing does not need to be the same as the more involved initial mix design qualification process.

STANDARD

COMMENTARY

procedures shall address the steps necessary for initial mix qualification and subsequent daily quality control operations.

Initial mix qualifications shall be documented in the plant files. Documentation shall, include trial batching and in-depth concrete testing. Mix qualification procedures shall include the establishment of acceptable tolerance ranges for test results of daily quality control testing.

Subsequent daily quality control operations must follow the daily quality control testing acceptance criteria established during the initial mix qualification.

3.1.1.5 Mix Compatibility When Using Face Mix

When using different mixes for face mix and back-up mix, the characteristics of each mix shall be considered to ensure there is minimal difference in shrinkage, thermal coefficient of expansion, and modulus of elasticity.

3.1.2 Water-Cementitious Materials Ratio

Water-cementitious materials ratio for each mix design shall be calculated and documented. Concrete that will be exposed to freezing and thawing shall contain entrained air and shall have water-cementitious materials ratio of 0.45 or less. Concrete which will not be exposed to freezing, but which is required to be watertight, shall have a water-cementitious materials ratio of 0.48 or less if the concrete is exposed to fresh water. For corrosion protection, reinforced concrete exposed to deicer salts, brackish water or seawater shall have a water-cementitious materials ratio of 0.40 or less.

Careful control of all water going into the concrete is important to achieving consistent, high quality concrete. Reducing the water-cementitious materials ratio increases concrete strength, reduces concrete permeability, and results in a more durable concrete.

The values of water-cementitious materials ratio cited in section 3.1.2 are needed for adequate durability.

It is recommended that the workability be achieved by using water-reducing admixtures instead of increasing cement contents. Without water-reducing admixtures in the concrete, it is likely that 600 to 700 pounds (270 kg

STANDARD

COMMENTARY

to 320 kg) of cement will be needed per cubic yard of concrete. Even higher cement contents may be needed if aggregate gradations are poor or if high slump concrete is used.

Very wet mixes from which the water is removed by pressure or vacuum de-watering contain little or no entrained air. However, such concrete can be durable if the water-cementitious materials ratio is low enough.

3.1.3 Air Content (Plastic)

The air content of concrete that will be exposed to freezing and thawing shall be within the limits given in Table 3.1.3.

TABLE 3.1.3
TOTAL AIR CONTENT FOR FROST - RESISTANT CONCRETE**

Nominal Maximum Aggregate Size

Size (inches)	*Air Content, %	
	Severe Exposure	Moderate Exposure
3/8	6.0 to 9.0	4.5 to 7.5
1/2	5.5 to 8.5	4.0 to 7.0
3/4	4.5 - 7.5	3.5 to 6.5
1	4.5 to 7.5	3.0 to 6.0
1 1/2	4.5 to 7.0	3.0 to 6.0

* For specified compressive strengths greater than 5,000 psi (34 MPa), air content may be reduced 1%.

** Table 3.1.3 is a modified version of Table 4.1, ACI 201.2R

3.1.4 Compressive Strength

A compressive strength test is defined as the average of the strengths of two specimens made from the same concrete batch, cured in the same manner, and tested at the same age. The compressive strength of the concrete as determined from test

Compressive strength is commonly specified using cylinders made, cured, and tested in a standard

STANDARD

specimens shall be equal to or greater than that specified by design. If no strength is specified, the strength shall be sufficient to minimize damage caused by product handling, and in no case shall the concrete strength be less than 2,500 psi (17 MPa) at the time the product is shipped.

COMMENTARY

manner, usually tested 28 days after the cylinders are cast. However, some specifications require minimum strengths at ages different than 28 days, and some require cylinders to be cured in the same manner as the concrete they represent.

If strengths are consistently low, several cylinders should be made from one batch; some should be cured in a standard manner (laboratory conditions defined in ASTM C31), while the rest are cured in the same manner as the product represented. If the strengths of those cured in the standard manner are lower than expected, the mix proportions must be adjusted to give higher strengths. If specimens cured in the standard manner have satisfactory strengths, while those cured with the products are low, curing must be improved or the mix adjusted, or both.

Most precast concrete producers furnish their products with strengths in excess of 4,000 psi (28 MPa). Lower strength concrete is damaged more readily while it is being handled. A minimum strength of 2,500 psi (17 MPa) at the time of shipment might be too low to minimize damage for

STANDARD

COMMENTARY

some types of products, so higher strengths are recommended. A minimum of 80 percent of the 28-day design strength is sometimes specified prior to shipping products.

3.1.5 Admixtures

Admixtures shall be used in accordance with the manufacturers' instructions. If more than one admixture is used in a concrete mix, data shall be obtained to assure that each admixture performs as required without adversely affecting the performance of the others. Admixtures shall be introduced into the concrete mix in a controlled manner to assure uniform distribution into the mix.

Admixture supplier shall supply certification of admixture dosing equipment. Current certifications shall be dated not more than one year at the end of the month from the date of the last test or certification.

Some admixtures conforming to ASTM C494 are affected by composition of the cement, particularly the tricalcium aluminate and the sulphur trioxide contents. Thus it is recommended that the effectiveness of admixtures be evaluated in concrete mixes at the plant so that the reaction between the cement being used and the admixture can be noted. Some admixtures are not compatible with other admixtures, particularly if they are introduced into the mix in a sequence other than that recommended by the manufacturer.

3.1.6 Plant Requirements:

1. Mix proportions for each mix shall be clearly listed and maintained in the plant files and at the mixer. The water – cementitious materials ratio of the mixes shall not exceed the limits stated in Section 3.1.2 and shall be documented in the mix proportion. The concrete shall be air-entrained if it will be exposed to freezing and thawing per Table 3.1.3.

2. Compressive strength (7- or 28-day age) of the concrete shall be tested a minimum of every 150 cubic yards (115 cubic meters) of concrete of each mix or once per week, whichever occurs first. Strength data shall be retained in the files for a minimum of three (3) years. If product is shipped prior to obtaining strength data, additional compressive cylinders shall be tested prior to shipping to ensure minimum strength requirements are met. Rebound hammer tests can also be used as an indicator for strength if the rebound hammer has been properly calibrated. Strength data shall be routinely reviewed and tracked by the quality control manager.

3.2 BATCHING AND MIXING

3.2.1 Requirements for Batching and Mixing Plants

Plants shall be equipped so that batching and mixing will result in adequately mixed concrete of the correct proportions with the desired workability of the fresh concrete and required properties of hardened concrete in adequate quantities to maintain the casting schedule. Plants for batching and mixing concrete and their operations shall conform to ASTM C94, "Standard Specification for Ready-Mixed Concrete." Alternatively, plants may conform to the requirements for batching and mixing given in ASTM C685, "Standard Specification for Concrete Made by Volumetric Batching and Continuous Mixing."

A wide variety of batch plants from manual to fully-automated can provide concrete of consistent quality and can conform to these requirements.

3.2.2 Storage of Cement and Supplementary Cementitious Materials

Separate bins or silos shall be provided for each type of bulk cement and supplementary cementitious materials. Bins and silos shall be watertight to prevent intrusion of moisture. Cement and supplementary cementitious materials in bags shall be stored under cover to prevent contact with moisture.

Cement will begin to hydrate when it comes in contact with water. Partly hydrated cement forms lumps, which are difficult to pulverize, and thus should not be used. If lumps of cement are discharged from the bin, the bin should be emptied and repaired if necessary. Bagged cement, which is lumpy, should be discarded.

STANDARD

COMMENTARY

3.2.3 Handling and Storage of Aggregates

Aggregates shall be handled and stored in such a manner that segregation of particle sizes is minimized, gradations are kept within specified limits, contamination from underlying soil does not occur and cross-contamination between adjacent aggregate stock does not occur.

In addition, organic matter (such as leaves and twigs) shall not be allowed to accumulate and plants shall not be allowed to grow in aggregate stockpiles.

Minimal handling of aggregates is recommended to curb segregation. Storing aggregates in conical piles should be avoided. Preferably aggregates should be stored on slabs or on planking in horizontal layers. Methods for minimizing segregation of aggregates are described in ACI 304, "Guide for Measuring, Mixing, Transporting, and Placing Concrete."

3.2.4 Batching Equipment

Weigh batching equipment shall be maintained and operated in accordance with ASTM C94 or ASTM C685.

For plants that utilize mass batching or a combination of mass and volumetric (for liquid) batching, the equipment must be capable of measuring and batching the concrete raw materials within the following tolerances:

Cement	±1%; for batches less than 1 cubic yard, 0 to +4%
Water	±1%
Fine Aggregates	±2%
Coarse Aggregates	±2%
Cumulative Weigh Batch Aggregate	±1%
Admixtures	±3% or ± dosage per bag of cement, whichever is greater

The tolerances given in this section are those specified in ASTM C94 and ASTM C685. Methods for calibrating the measuring equipment are outlined in those standards. There are two reasons for displaying calibration records prominently. Records that show deviations should be used by plant personnel to obtain correct readings. Also, inspectors from outside agencies can be assured that the equipment has been calibrated recently.

Scales shall be calibrated each year or any time there is a reason to question their accuracy. Calibration stickers shall be displayed prominently at the batch control location. Current calibration and stickers shall be dated not more than one year at the end of the month from the date of the last test or certification. Records for calibration of batch plant scales shall be readily accessible to the equipment operator.

Note that when using self-consolidating concrete, very small discrepancies in batch water content can be detrimental to the desired properties of the mix.

STANDARD

COMMENTARY

Scale calibrations shall include the entire anticipated range of use and the percent error at each test weight shall be documented. Scales shall be calibrated to within 0.2% of the certified test weight at each quarter of the anticipated load range.

Liquid admixtures shall be measured by weight or volume. Powdered admixtures shall be measured by weight. Calibration of the admixture dispensers shall be performed each year. Current calibration reports shall be dated not more than one year at the end of the month from the date of the last test or certification.

Plants that utilize volumetric or continuous batching shall be capable of proportioning the component materials in concrete within the following tolerances:

Cement	0 to + 4% (weight)
Water	±1% (weight or volume)
Fine Aggregates	±2% (weight)
Coarse Aggregates	±2% (weight)
Admixtures	±3% (weight or volume)

3.2.5 Discharge of Materials into Mixers

Mixer drum or blades shall be rotating while materials are discharged into the mixer. Materials shall be discharged into the mixer in a sequence that ensures a homogenous mix.

Admixtures shall be fed into the mixer in a sequence that is recommended by the admixture supplier and to ensure uniform distribution in the mix. The sequence of discharge and mixing shall be documented and maintained at the concrete batching station.

Materials should be discharged into the mixer in a sequence that approaches the ideal condition. Each facility should develop and document a sequence that results in a uniform mix.

For lightweight aggregates, pre-wetting is recommended to prevent mix-water absorption. It is also advisable to develop a specific batching sequence starting with the lightweight aggregates and part of the water before adding the other materials.

3.2.6 Mixers

The batch size shall not exceed the capacity recommended by the manufacturer. Mixers shall be capable of producing concrete

The condition of the mixer should be checked daily

STANDARD

COMMENTARY

of uniform consistency and uniform coarse aggregate distribution as required by ASTM C94 for batch mixing, or ASTM C685 for continuous mixing.

Mixers shall be checked daily for cleanliness, clearances on blades and shoes, proper gate seals, lockout controls.

for mortar or concrete build-up and worn blades. The manufacturer's drawing of the mixer tools showing all dimensions should be available so that the amount of wear can be determined. Blades and mixing tools worn more than 10% should be adjusted or replaced. Concrete and mortar build-up should be removed and discarded.

3.2.7 Mixing

Concrete may be mixed by (a) stationary central mixer, (b) mixing screw (volumetric type), or (c) truck mixing and delivery.

For batch mixers, mixing time or number of drum rotations shall be established by uniformity tests in ASTM C94, either by the equipment manufacturer or by qualified plant personnel.

Daily reports of actual concrete mix proportions used in each batch and quantities of produced concrete shall be kept by the precast plant for at least three (3) years.

ASTM C94 gives the maximum permissible differences in results of tests of samples of concrete taken from two locations in a batch. Items to be tested include unit weight, air content, slump, coarse aggregate content, and compressive strength. If the differences in values are within the tolerances given in ASTM C94, the mixer should be approved. However, if the differences in test results are greater than the tolerances in ASTM C94, the mixer should not be used.

3.2.8 Ready-Mixed Concrete

Concrete supplied by a ready-mixed concrete producer shall meet the requirements of ASTM C94 (whether located at the same location as the precast plant or off-site) and shall conform to the requirements given in Sec. 3.2.1 through 3.2.7. The facilities for batching concrete supplied by a ready-mixed concrete producer shall conform to the same requirements of batch plant facilities cited above. Certification of the supplier's facilities by the National Ready Mixed Concrete Association

The plant should verify that the ready-mixed concrete supplier is operating in accordance to ASTM C94.

It is suggested that plants consider testing every truck load for slump,

STANDARD

COMMENTARY

(NRMCA) or State DOT shall be evidence of conformance to Sec. 3.2.1 through 3.2.7. In addition, the plant shall maintain a file of current mixture designs, batch plant printouts, truck delivery receipts, and appropriate raw material certifications and gradations. Total quantities of raw materials used by the precast plant shall be used to determine the required frequency of raw materials testing.

Concrete testing shall be performed per Section 5.3 of this manual at the location of final placement.

Truck delivery receipts shall be received with each load. Record all water added at the plant to the ready-mixed concrete deliveries.

“Bring-back” concrete or any other concrete originally intended for an entity other than the precast concrete manufacturer shall not be used for production of precast concrete products.

3.2.9 Plant Requirements:

1. Aggregate stockpiles shall be properly configured to minimize segregation and contamination.
2. Scales shall be calibrated each year and the calibration sticker displayed prominently at the concrete batch control station. Current calibration reports and stickers shall be dated not more than one year at the end of the month from the date of the last test or certification.
3. Batching tolerances for all concrete components shall conform to the tolerances listed in Section 3.2.4.
4. Mixers shall be checked daily for cleanliness, clearances on blades and shoes, proper gate seals, lockout controls, etc.
5. Ready-mixed supplied concrete shall be from a NRMCA or State DOT certified plant or conform to all above requirements. Documentation of the ready mix supplier's conformance shall be maintained in the files at the precast plant. Truck delivery receipts and any water added at the precast plant shall be documented. Only fresh concrete intended for the precast concrete manufacturer is permitted to be used for production of precast concrete products.
6. Daily reports of actual concrete mix proportions used in each batch and concrete quantities produced shall be kept by the precast plant for at least three (3) years.

temperature, air content, and density prior to casting products to ensure consistency beyond the minimum requirements of Section 5.3. Mark any added water on the delivery batch ticket for each truck and keep on file.

CHAPTER 4 – PRODUCTION PRACTICES

4.1 GENERAL

4.1.1 Plant Layout

The physical layout of the plant shall be such that production, handling, storage and shipment of concrete products can be done in an efficient, safe manner and with minimal product damage.

The plant layout shall incorporate the following general guidelines:

1. Minimize transport distances of fresh concrete.
2. Adequate workspace to minimize safety and tripping hazards.
3. Avoid stripping or lifting products over personnel or equipment.
4. Prevent marking or splash on other products during casting operations.
5. Adequate storage space for materials.
6. Adequate space to strip products and perform post-pour inspections and repairs.

4.1.2 Housekeeping

Each plant shall have an active housekeeping program. The purpose of the program shall be to provide a clean and safe environment so that quality precast concrete products can be manufactured efficiently.

The plant QC Inspector shall spot-check housekeeping daily.

Because of the wide range in sizes of precast concrete manufacturing plants and in the diversity of products manufactured, there can be no standard or ideal organization structure or plant layout.

A clean plant provides a much better environment for producing quality products than does a cluttered plant. A clean plant is also good for morale of workers, minimizes safety hazards, and generally improves production efficiency and quality.

Some plants require each worker or crew to be responsible for the cleanliness of a particular area of the plant. In other plants a “clean-up” or housekeeping crew is responsible for the cleanliness of the entire plant.

4.1.3 Forms and Forming Equipment

Forms and forming equipment for manufacturing precast products shall be of a quality that prevents product damage due to forces and vibrations subjected to the forms.

All forms and forming equipment (including pallets, headers, truing rings) shall be measured prior to initial use and not less than each year thereafter for dimensional conformance with applicable tolerances. Current reports shall be dated not more than one year at the end of the month from the date of the last report.

Forms shall be carefully cleaned of concrete build-up after each use. Coatings of form release agents shall not be allowed to build up.

Forms for manufacturing precast concrete products shall be of the type and design consistent with industry standards and practices. They should be capable of consistently providing uniform products and dimensions. Forms shall be constructed so that the forces and vibrations to which the forms will be subjected can cause no product damage.

In general, management attitude will dictate the effort expended in keeping a plant clean.

Forms that are well built and properly maintained can be used almost daily for 20 years or more. Quality forms are rugged yet produce surface defect-free products within dimensional tolerances. Typically, form dimension tolerances should be about half the product tolerances specified.

Follow your form manufacturer's form leveling and setup recommendations.

It is suggested that plants give each piece of forming equipment a unique identification number in order to easily track and document their measurements

A routine maintenance program to repair hinges, remove bulges, minimize seam leakage, etc.; can result in improved quality as well as reduced production costs.

4.1.4 Handling Equipment

Equipment such as hoists, overhead cranes, gantries, mobile cranes, and fork lift trucks shall be used to lift and handle products which weigh less than the rated capacity of the equipment.

Inspection and maintenance records for all handling equipment must be maintained in accordance with applicable requirements.

Routine inspections should be made of all handling equipment to assure that safety is not compromised. Worn cables and other parts should be replaced or repaired. The equipment operators should make daily

inspections of all handling equipment.

Ensure all crane and lift operators are properly trained and meet OSHA requirements. Forklift operators should be familiar with local and OSHA safety requirements and the NPCA Guide to Plant Safety.

4.1.5 Machine-Made and/or Dry-Cast Products

Precast concrete products that are manufactured by mechanized equipment and/or dry-cast process shall conform to the applicable provisions of this manual.

Verification of the reinforcing steel for conformance with the design shall be performed and documented on a minimum of one (1) reinforcing steel cages or 3% of each production run daily, whichever is greater, chosen on a random basis by QC personnel for products produced in the plant with mechanized equipment. At least one cage shall be checked when a shift change occurs during the course of a production run and whenever a setting is changed. These reinforcing steel checks shall be documented and maintained in the plant records for a minimum of three (3) years.

Dimensions of machine-made products shall be within acceptable tolerances regardless of any slumping of the concrete after stripping.

Dimensional checks of machine-made products shall be performed daily for each type of product cast. Dimensional checks shall be performed on a minimum of one (1) product or 3% of each production run daily, whichever is greater, chosen on a random basis by QC personnel. These dimensional checks shall be documented and maintained in the plant records for a minimum of three (3) years.

If non-conforming product is discovered, the plant shall take immediate action to correct all non-conforming issues.

Many products such as patio stones, interlocking pavers, and manhole sections can be dry-cast or manufactured with mechanized equipment. In such operations, control of the concrete mixture is critical because the products are stripped immediately after they are cast, and the concrete units must retain their shape.

See section 4.2.1 for inspection requirements for reinforcement that is not fabricated in the plant using mechanized equipment.

4.1.6 Architectural Precast Concrete

Architectural precast concrete is defined as concrete which will be permanently exposed to view and when required by owner or specification requires special care in selection of concrete materials, forming, placing and finish to obtain the desired architectural appearance.

By its inherent nature, the level of quality, in terms of appearance, is of the utmost importance. Final product shall match previously approved samples and/or already established industry standards stated in individual job specifications. Consistent quality shall be maintained through documented plant-specific procedures, as required in Section 1.1.2. Strength and durability shall not be compromised for architectural appearance, unless a specific application or specification allows deviations.

Natural stone or clay products may be used as a veneer to create the desired finish. Procedures to accommodate differences in thermal and moisture movement between the veneer and the concrete shall be established.

4.1.6.1 Surface Finishes

All exposed surfaces shall be free of form defects, joint marks and shall be within the color variation as defined by the approved samples and/or mock up. All details such as false joints, chamfers, etc shall be as designed on the approved shop drawings.

Architectural finishes shall be according to the requirements of project documents and performed per industry standards or supplier specifications.

Precast concrete producers shall submit finishes for approval when required by the project documents. Life size mockups are recommended for the approval of architectural finishes, because color variations and surface imperfections are not always apparent on small scale samples. The sample finishes shall be approved prior to the start of production.

4.1.6.1.1 As Cast

Surfaces shall be cast against approved forms following industry practices in cleaning forms, designing concrete mixes, placing and curing concrete. Slight color variations, small surface holes (up to ¼ inch diameter) caused by air bubbles will be accepted but no major imperfections, excessive honeycombing, sand streaks or other major defects shall be permitted. Particular attention should be paid to selection of raw materials, and control

Concrete products can be created through adjustments to shape, color, finish/texture or design to create an appearance that fits the needs of the public and/or project specific design requirements. Color can be affected by the choice of cement, coarse and fine aggregates or pigment used and how they are proportioned. Finishes can be applied in a number of ways such as sandblasting, pressure wash or other mechanical means.

Various procedures for an architectural finish may vary from plant-to-plant. It is the precast concrete producer's responsibility to establish the proper methods to achieve a specific finish.

Depending on the type of product, a wide range of strength and durability requirements may be expected (i.e. a birdbath and a post-tensioned wall panel will not necessarily be expected to perform equally).

Careful attention shall be made when using veneers. Establishing standards to accommodate material incompatibility shall be well researched.

of water-cementitious materials ratio in order to minimize color variation.

Proper casting procedures and mix design as per chapter 4 shall be used to minimize air voids on surfaces.

Mockups should be cast for approval for acceptance of color variation and quantity of voids.

4.1.6.1.2 Exposed Aggregate Finish

By means of chemical surface retarders which shall be removed by water washing, brushing or abrasive blasting or a combination as defined in the project specifications. The finish shall be free of honeycombing or segregation of aggregates.

Surface retarders must be applied evenly and consistently to the form. Keep concrete drop heights low during placement to reduce damage to the surface retarder. Also, vertical and curved sections may have surface retarders scoured during placement. Place the concrete from the lowest to the highest part of the form. Once the retarder has been applied to the form, water shall not come in contact with that retarder. Follow retarder manufacturer's recommendations.

4.1.6.1.3 Abrasive Blast Finish

Materials used for blasting shall be free of deleterious substances. Proper safety gear should be worn to prevent inhalation of fine particles. Pieces shall be blasted at the same age to ensure consistency.

Remove the surface of the concrete, to a specified approximate depth, by means of an abrasive grit which is typically projected at the surface pneumatically.

4.1.6.1.4 Acid Etch Finish

Acid etching should be performed only after adequate curing and a minimum compressive strength of 4,000 psi. Prior to applying acid, paint or seal all exposed metal surfaces and exposed insulation.

The concrete surface must be thoroughly wetted prior to applying acid to avoid streaking and overexposure. Pay special attention to returns, flat areas or locations where acid may puddle or concentrate, as this may also cause overexposure. The surface should be flushed with clean water to remove all residue within 15 minutes of the original acid application.

Use only acid-resistant siliceous aggregate in the concrete. Provisions must be made to protect hardware and insulation if applicable.

4.1.6.1.5 Honed or Polished

Remove the surface of the concrete, to a specified approximate depth, by means of grinding with water and an abrasive grit. The compressive strength of the concrete should be a minimum of 5,000 psi, with all repairs and filling of bug holes completed and cured prior to grinding.

4.1.6.1.6 Bush-hammered or tooling

The use of tooling techniques, hammers or equipment to abrade the surface of the precast should be performed by only trained personnel. The protective cover of the reinforcement should be increased to account for the removed concrete surface.

4.1.6.1.7 Unformed Surfaces

Surfaces shall be finished with a vibrating screed, or by hand with a float. Normal color variations, minor indentations, minor chips and spalls will be accepted but no major imperfections, excessive honeycombing or other major defects shall be permitted. If no finishing procedure is specified, such surfaces shall be finished using a strike-off to level the concrete with the top of the form.

4.1.6.1.8 Special Finishes

Trowel, broom or other finishes shall be according to the requirements of project documents and performed per industry standards or supplier specifications.

Precast concrete producers shall submit finishes for approval when required by the project documents. The sample finishes shall be approved prior to the start of production.

4.1.6.1.9 Architectural Finishes

Architectural finishes shall be according to the requirements of project documents and performed per industry standards or supplier specifications.

Precast concrete producers shall submit finishes for approval when required by the project documents. Life size mockups are recommended for the approval of architectural finishes, because color variations and surface imperfections are not always apparent on small scale samples. The sample finishes shall be approved prior to the start of production.

With all finishes, aggregate exposure shall be no greater than $\frac{1}{3}$ the average diameter of coarse aggregate and not more than $\frac{1}{2}$ the average diameter of smallest size coarse aggregate.

A groove or recess shall be incorporated into the surface of a unit having two or more different mixes or finishes. The different face mixes shall have relatively similar behavior with respect to shrinkage, to avoid cracking at the groove or recess.

4.1.6.1.10 Embedded Veneer

When designing with veneer, it is important to take into account differences in properties between the veneer material and the concrete backer. These and other factors such as concrete shrinkage rates, exposure, span lengths, connection design and thickness of veneer material and precast backer may lead to an increase in potential bowing (typically outward). The differences in coefficients of thermal expansion between the veneer material and the concrete backer should be minimized (see Table 1). Otherwise, length change may occur at different rates resulting in differential stresses that may result in outward bowing. To offset this concern precasters may build an inward bow or camber into the form when casting the panels, use prestressing or, when panel thickness allows, use a double reinforcing cage. Additional tie-back connections have also been known to help restrain bowing potential.

4.1.6.1.10.1 Stone Products

A bond breaker is typically used to prevent concrete from directly bonding with the stone. Bond breakers allow for differential movement between the precast concrete backer and the stone veneer, helping prevent staining and cracking of the veneer. Some common materials used to create a bond breaker are:

- 6 to 10 millimeters polyethylene sheet
- Closed cell, 1/8- to 1/4-inch-thick foam pad
- Thin liquid bond breaker (such as polyurethane)

A flexible, mechanical anchor should be used to attach stone to precast concrete. Anchors should also be corrosion-resistant. Anchors differ in shape, depending on the type and strength of the stone. However, most anchors have a recognizable cross pattern with the veneer-embedded portion arranged at a 30 to 45 degree angle from the back of the stone, penetrating approximately 3/4-inch or half the thickness of the veneer – whichever is greater.

4.1.6.1.10.2 Clay Products

Clay products are typically cast into or bonded to the concrete, creating a monolithic unit. Properties of the clay product, such as coefficients of thermal expansion (see Table 1), absorption, modulus of elasticity and volume change should be considered in the design as well as in-service conditions, such as temperature differentials between the exterior and interior surfaces.

Many clay products are “fired” and expand in the presence of moisture, including effects from humidity. However, this can be compensated in the precast concrete panel. For example, grout or concrete mortar between the clay products shrinks and helps compensate for expansion. The mortar joints may also experience elastic deformation under stress, which can compensate for expansion of the clay brick.

There are specific recommendations when using certain clay products in precast concrete. First, while there are several types of bricks available, not all bricks are acceptable for use in precast. Precast concrete requires tight tolerances in the individual bricks due to the form tolerances and the alignment of units. Bricks should meet ASTM C1088, Type TBX. (Note: the recommended tolerance for bricks used in precast is plus zero or minus 1/8 inch.) Otherwise, bricks may be moved or tilted by concrete placement and require repair. As for non-brick clay products, glazed or unglazed ceramic tile should conform to ANSI A137.1 and adhere to a tolerance of 1 percent. Terra cotta is usually a custom product and has a maximum length and width tolerance of plus or minus 1/16 inch.

The absorption and initial rate of absorption of clay products directly bonded to precast concrete will have an effect on bond. Brick absorption should be between 6 percent and 9 percent when tested in accordance with ASTM C216. Bricks should have an initial rate of absorption less than 20 grams per minute per 30 square inches, according to ASTM C67. These bricks are not required to be wetted. Bricks exceeding this value should be wetted to avoid removing moisture from the concrete and reducing bond. Terra cotta is typically soaked prior to use to avoid excessive suction of the moisture from the curing concrete. Generally, the bond strength between a veneer material and precast concrete exceeds the bond strengths of conventional field-laid applications.

Clay products should also have some physical characteristic for mechanical means of bonding with the concrete such as grooves or scoring on the back side of the piece.

Almost any pattern, such as running bond or stack patterns for brick can be used. Custom designs or combinations of materials may also be incorporated. Units should be designed to minimize cutting of the smaller veneer products.

4.1.7 Plant Requirements:

1. Maintain an active housekeeping plan. Continual efforts shall be made by all production personnel to maintain a clean work area. Spot-check by QC Inspector at least once each work shift.
2. Maintain records of form and forming equipment dimensional checks on all new equipment and each year thereafter. Current reports shall be dated not more than one year at the end of the month from the date of the last report.
3. Maintain inspection records of all handling equipment in accordance with applicable requirements.
4. For reinforcement fabricated with mechanized equipment and used in machine-cast, or dry-cast products, perform and document reinforcing checks on a minimum of one (1) reinforcing cages or 3% of each production run daily, whichever is greater. At least one cage shall be checked when a shift change occurs during the course of a production run and whenever a setting is changed.
5. For machine-cast and/or dry-cast products, dimensional checks shall be performed and documented on a minimum of one (1) products or 3% of each production run daily, whichever is greater.
6. Appearance of architectural precast concrete shall match approved samples and meet industry standards. Compatibility of veneers shall be established and documented. Production and quality control measures shall be developed and documented in the plant-specific QC manual.
7. Unless otherwise noted, maintain records for a minimum of three (3) years.

4.2 FABRICATION OF REINFORCEMENT AND BLOCKOUTS

4.2.1 Fabrication of Reinforcement*

All reinforcing steel shall be fabricated to a detailed reinforcing steel plan document in conformance with the precast concrete product tolerances and / or tolerances provided in the project specifications or plans. If no dimensional tolerances have been established, or references given, the plant shall specifically state on the plan documents or in the plant specific quality control manual, the dimensional tolerance scheme that will govern for the product; such as but not limited to the Concrete Reinforcing Steel Institute (CRSI) publication, "Placing Reinforcing Bars" and / or the Reinforcing Steel Institute of Canada / Institut D'acier D'armature du Canada (RSIC / IAAC) publication, "Reinforcing Steel, Manual of Standard Practice"

Reinforcing steel cages shall be inspected for conformance to approved design requirements and documented with the pre-pour inspection. The inspection requirements are detailed in Section 4.3.3 Positioning of Reinforcement.

All reinforcing bars shall be bent in accordance with standard CRSI and RSIC / IAAC fabrication practices and bend diameters shall not be less than those established by CRSI and RSIC / IAAC.

Cages of reinforcement shall be fabricated either by tying or clipping the bars, wires or welded wire reinforcement into rigid assemblies, or by welding where permissible in accordance with Section 4.2.2.

Damage to the coating on epoxy-coated reinforcing steel shall be repaired with patching material in a manner conforming to the patching material manufacturer's recommendations. When epoxy-coated reinforcing steel is cut or welded, the cut ends and the weld areas shall be repaired with patching material. Epoxy-coated reinforcing steel shall not be flame cut.

** Critical Requirement – plants participating in the NPCA Plant Certification Program must receive a minimum passing grade, as shown on the grading schedule, for section 4.2.1 and others designated as Critical Requirements, when applicable.*

Adequate concrete cover is required in order to protect the steel against corrosion and to provide adequate structural bond between the steel and concrete. Cages should be made so that concrete cover requirements are maintained.

When inspecting reinforcing steel cages, the approved design documentation they are compared to may consist of plant shop drawings.

4.2.2 Welding of Reinforcing Steel

Cages of reinforcement may be welded if permitted by the applicable ASTM product standards. Welding of reinforcing steel may be also permitted in other situations as determined by the manufacturer where the steel is not used for structural purposes.

In all cases care and discretion must be used to assure that the integrity of the precast product is maintained.

Reinforcing steel used for structural purposes may be welded as long as it is accomplished in compliance with standards set forth in the American Concrete Institute's "Building Code Requirements for Reinforced Concrete" (ACI 318) and The American Welding Society's "Structural Welding Code - Reinforcing Steel" (AWS D1.4).

Welding of ASTM A615 reinforcing steel is not generally an acceptable practice. According to the American Welding Society D1.4 Structural Welding Code for Reinforcing Steel, the carbon equivalent for bars to be welded should be less than 0.45 percent for bars larger than #7 and 0.55 percent for #6 bars and smaller. If ASTM A615 steel is to be welded, the carbon equivalent shall be calculated and the bars preheated if necessary.

Use of ASTM A706 weldable grade rebar for welding applications is acceptable.

The Carbon Equivalent (CE) for ASTM A615 reinforcing steel is calculated as follows:

$$CE = \%C + \%Mn/6$$

The Carbon Equivalent (CE) for ASTM A706 reinforcing steel is calculated as follows:

$$CE = \%C + \%Mn/6 + \%Cu/40 + \%Ni/20 + \%Cr/10 - \%Mo/50 - \%V/10$$

4.2.3 Welding of Steel Assemblies

Welding of steel assemblies which are cast into or attached to precast concrete products shall be performed in accordance with American Welding Society D1.1, "Structural Welding Code - Structural Steel."

Reference the American Concrete Institute's Building Code (ACI 318) and The American Welding Society publication (AWS D1.4). Each references each other within their codes. Both contain complete and useful guidelines for welding of reinforcing steel.

Most structural steel assemblies in precast concrete consist of ASTM A36 steel, which is readily weldable with standard equipment. Welding of stainless steel and steels

other than ASTM A36 steel should be performed in accordance with AWS D1.1.

4.2.4 Fabrication and Positioning of Blockouts

Blockouts may be made of any rigid, non-absorptive material that will not harm the concrete and that can be held in place during the casting and curing of concrete. Dimensional blockout tolerances shall be specified for each product and blockout type.

Blockouts may be held in place during casting with non-corrosive supports or with reinforcing steel, unless prohibited by project specifications.

Expendable blockouts are often made of non-absorptive expanded polystyrene. Reusable blockouts are made of a variety of materials such as wood, steel, sheet metal, rubber, neoprene, and a variety of plastics. Most blockouts tend to float during and immediately after casting concrete so they must be held rigidly in place. Blockouts should be designed to minimize damage to the concrete when they are removed. Coring holes in the hardened concrete is sometimes used instead of installing blockouts.

4.2.5 Plant Requirements:

1. Reinforcement shall be fabricated within applicable tolerances and supported rigidly.
2. Welding of ASTM A615 reinforcing steel is allowed when following an approved welding procedure meeting the requirements of AWS D1.4/D1.4M. Copies of the approved welding procedure shall be included in the Plant Specific Quality Control Manual and available for review.
3. Blockouts shall be non-absorptive and held rigidly in place with non-corrosive supports or with reinforcing steel, unless prohibited by project specifications.

4.3 PRE-POUR OPERATIONS

4.3.1 Cleaning of Forms

Forms shall be cleaned after each use. Concrete, tape, polystyrene, and other materials adhering to the forms shall be removed.

It is generally easiest to clean forms immediately after products are stripped. Waiting too long allows the concrete to bond more tenaciously to the forms.

4.3.2 Application of Form Release Agent

Form release agent shall be applied after the forms are cleaned and, if necessary, the seams sealed. Reinforcement and other items to be embedded in concrete shall be free of form release agent. Care shall be taken to avoid over-application of form release agent, which may lead to puddling. If puddling does occur, the puddle shall be removed prior to casting.

Form release agents prevent concrete from bonding or adhering to forms. Reinforcement, inserts and other embedment items on which form release agents have been inadvertently applied may fail to bond to the concrete and may be ineffective in performing their intended functions. It is recommended that form release agents be applied in a thin coat and there should be no puddles.

4.3.3 Positioning of Reinforcement*

Reinforcing steel shall be positioned as specified by the design and the concrete cover must conform to product requirements. Unless otherwise required, the tolerance on concrete cover shall be one-third of that specified but not more than ½ inch. Concrete cover shall not be less than ½ inch, however concrete cover greater than ½ inch is recommended. Positive means shall be taken to assure that the reinforcement does not move significantly during the casting operations. Cages shall be supported away from all form surfaces. Liberal use of chairs, spacers, and positioning wheels is encouraged especially with small diameter bars or wire. Rolled welded-wire reinforcement shall be mechanically straightened to use in straight-walled products.

** Critical Requirement – plants participating in the NPCA Plant Certification Program must receive a minimum passing grade, as shown on the grading schedule, for section 4.3.3 and others designated as Critical Requirements, when applicable.*

Plants shall maintain a documented process of reinforcing steel / cage inspections including information on the required cage design versus the actual cage used; including the following as applicable to the product produced:

- Bar size and/or WWR bar diameter;
- Bar spacing and/or WWR style;
- Steel area (A_s);
- The quantity of bars;
(Inspections may include one or more of the above per detailed reinforcing steel plan documents);
- The effective depth (d), (the distance from the compressive face to the centroid of the tensile reinforcement member);
- The concrete cover, never less than $\frac{1}{2}$ " clear;
- The lap splice length;
- Cage dimensions: length, width, height, and/or diameter, as applicable;
- Reinforcing steel condition:
 - Clean or light red rust, not flaking or pitted;
 - Free from oils, dirt, or other contaminants;
 - If welded, meets the requirements of section 4.2.2;
 - If welded, does not contain any damage, such as gouges and undercut;
- Reinforcement hooks and bends (90° and 180°). If design, project specifications, and/or detailed reinforcing steel plans require a bend in reinforcing steel around a corner, substitution of straight sections tied together shall not be acceptable practice.

For precast products made in accordance with standards like ASTM (e.g. manholes, barriers and utility structures) the reinforcement positions are cited in the standards. For products not made in accordance with standards, ACI 318 generally determines reinforcement positioning.

Verification of the reinforcing steel for conformance with the design shall be performed and documented on a minimum of one (1) reinforcing steel cage or 3% of each production run daily, whichever is greater, chosen on a random basis by QC personnel for each product category produced in the plant. At least one cage shall be checked when a shift change occurs during the course of a production run.

These reinforcing steel checks shall be maintained in the plant records for a minimum of three (3) years.

4.3.4 Positioning of Miscellaneous Embedded Items

Embedded items shall be positioned at locations specified in the design. Inserts, plates, weldments, lifting devices and other items to be embedded in precast concrete products shall be held rigidly in place during casting operations.

Some embedded items are placed in the concrete after concrete has been cast but before it hardens. If embedded items such as lifting inserts are required to develop significant stresses, care should be taken to ensure adequate consolidation of the concrete around the item.

4.3.5 Plant Requirements:

1. Pre-pour inspections shall be performed prior to casting each form. Form dimensions, form tightness, form cleanliness, form release agent application, positioning and securing of reinforcing, embedded items and blockouts shall be checked.
2. The plant shall have a procedure to identify when a form has received a pre-pour inspection and is ready for casting.
3. Documentation of the pre-pour inspections can be on a piece or production shift basis and must be documented at least daily.
4. Pre-pour inspections for machine-made products shall be a minimum of checking the form condition prior to each work shift and checking and documenting reinforcing cages as required in Section 4.1.5.

4.4 CASTING CONCRETE

4.4.1 Transporting Concrete

Concrete may be transported from the mixer to the casting location by any means that does not contaminate the concrete or cause excessive segregation. Concrete discharged directly from the mixer into the forms is permitted.

After concrete is discharged from a mixer all casting operations tend to cause segregation. Excessive segregation is undesirable. Thus all casting operations should be done in such a way that segregation is minimized. An effective method of minimizing segregation is to minimize handling of the concrete. If possible, concrete should be delivered directly to the forms after it is discharged from the mixer.

4.4.2 Depositing Concrete into Forms

Conventional concrete shall be deposited into forms as near to its final location as practical keeping free fall of concrete to a minimum.

SCC shall be deposited into forms at a minimum distance to avoid segregation and allowed to flow freely in order to completely fill the form.

Generally concrete can be deposited into forms with minimal free fall. Conventional concrete (not SCC) should first be deposited in one corner or edge of flat forms and additional concrete should be deposited into previously cast concrete until the form is filled. For vertical forms such as walls or pipe sections, concrete should be cast in horizontal layers instead of depositing the concrete to full height at one point and allowing the concrete to flow to other locations. There are exceptions to that rule. For example, when using SCC or when

casting a wall section with a large rectangular blockout, concrete is generally cast high on one side of the blockout and the concrete is allowed to flow beneath the blockout until the level of concrete on the opposite side is higher than the bottom of the blockout.

Similarly, when casting an open-top, five-sided box, concrete is allowed to flow from one vertical side beneath the top form of the bottom slab until the concrete begins to rise on the opposite side. For such products, the use of high-range water reducers (superplasticizers) and continuous vibration are recommended unless a self-consolidating concrete mix is used.

4.4.2.1 Placing Face Mix

When placing a face mix, care must be taken to avoid coating the reinforcing with cement paste that may affect the proper bonding of the back-up mix.

4.4.2.2 Placing Back-up Mix

When placing back-up mix, care must be taken not to disturb face mix.

4.4.3 Consolidating Concrete

Concrete shall be consolidated in such a manner that segregation of the concrete is minimized. Vibrators used to consolidate concrete shall have frequencies and amplitudes sufficient to produce well-consolidated concrete.

Internal vibrators shall be lowered vertically into the concrete without being forced downward until the tip of the vibrator reaches the bottom of the form or until it penetrates into a

Proper use of vibrators to consolidate concrete requires trained operators. High slump concrete, such as concrete with slumps greater than about 5 inches can easily be over-vibrated thus causing

previously consolidated lift. Vibrate the concrete until air bubbles within the vibrator's field of action essentially stop coming to the surface. Withdraw the vibrator slightly slower than it was lowered. Reinsert the vibrator making sure the fields of action overlap and repeat the vibration process until all of the concrete in the product has been consolidated. Do not use vibrators to move concrete laterally.

External vibrators (form vibrators) shall be mounted on the form structure in locations that best distribute their impact, but not directly on the form skins. External vibrators shall operate until air bubbles essentially stop coming to the surface.

Surface vibrators (vibrating screeds) shall be moved at a rate such that air bubbles essentially stop coming to the surface.

Similarly, vibrating tables shall operate only long enough that air bubbles essentially stop coming to the surface.

Consolidation of machine-made products shall be considered to be adequate if the products are free of honeycombed areas.

SCC is often referred to as concrete that does not require vibration. For more intricate formwork, or formwork containing heavy reinforcement or blockouts, the producer may find that light vibration or tapping of the forms will allow for the concrete to be fully compacted. This can eliminate problems of bugholes, honeycombing, voids and incomplete filling of formwork.

4.4.4 Finishing Unformed Surfaces

Unformed surfaces of wet-cast precast concrete products, such as step and, platform slabs which will serve as wearing surfaces for foot traffic or light vehicular traffic, shall be finished as specified. If no finishing procedure is specified, such surfaces shall be finished using a strike-off to level the concrete with the top of the form.

excessive segregation. Low slump concrete, (i.e., slump less than about 3 inches) is seldom over-vibrated to the point that excessive segregation occurs. Excessive vibration can reduce the amount of entrained air in the concrete and can adversely affect the durability of concrete exposed to freezing and thawing environments. Trained operators follow the procedures given in Sec. 4.4.3 and can sense the effectiveness of vibration by watching the surface, and by the sound of the vibrator when the concrete is fully consolidated.

Refer to Section 3.1.1 for the use of self-consolidating concrete.

After concrete has been consolidated and struck off, no finishing, except perhaps edging, should be done until the concrete is stiff enough to support the weight of a man without leaving footprints deeper than about 1/4 inch. Excess bleed water on the surface should be removed using a squeegee or a rubber hose pulled across the surface before finishing the concrete. The surface should then be floated

STANDARD

COMMENTARY

using a wood or magnesium float, followed by troweling, if required. For hard, dense surfaces, repeated trowelings may be needed.

Recommended procedures for finishing are given in ACI 302, "Guide for Concrete Floor and Slab Construction."

ACI 350, "Environmental Engineering Concrete Structures" cites the surface finish as a significant factor for water tightness.

4.4.5 Secondary Pours

For products that require secondary pours, procedures shall be established to assure that concrete cast during the secondary pour adequately bonds to the precast concrete product and becomes an integral part of that product.

The surfaces of the product against which the secondary pour is to be made should be free of laitance, dirt, dust, grease or any other material that will tend to weaken the bond between the original and new concretes. If the surface is very smooth, it should be roughened to help promote good bond. The procedures given in Sec. 4.7.1 may be useful in assuring secondary pours of adequate quality and bond.

4.4.6 Hot Weather Precautions

In hot weather the temperature of concrete at the time of placing shall not exceed 90 degrees F (32 degrees C).

For the purposes of this manual and according to ACI 305R, "Hot Weather Concreting," hot weather is defined as any combination of the following conditions that tend to impair the quality of freshly-mixed or hardened concrete by accelerating the rate of moisture loss and the rate of cement hydration:

- High ambient temperature
- High concrete temperature
- Low relative humidity
- Wind
- Solar radiation

Special precaution shall be taken in hot weather for concrete that is cast out-of-doors in order to prevent plastic shrinkage cracking and low strengths. These precautions may include:

1. Using cold water or adding ice as part of the mixing water.
2. Sprinkling aggregate stockpiles.
3. Fog spraying forms immediately prior to casting.
4. Placing fog sprays upwind and above the products during concreting, particularly during finishing of unformed surfaces.
5. Application of a product that aids in the control of evaporation of water from the concrete surface, such as wet burlap, plastic sheeting and / or curing compound as soon as concreting is completed.
6. Monitor concrete temperatures during curing.

4.4.7 Cold Weather Precautions

In cold weather the temperature of concrete at the time of placing shall not be less than 45 degrees F (7 degrees C).

For the purposes of this manual and according to ACI 306R, "Cold Weather Concreting," cold weather is defined as a period when the ambient air temperature of the casting environment, for more than three (3) consecutive days, the following conditions exist:

- The average daily air temperature is less than 40 degrees F (5 degrees C), and

There are generally more problems in placing concrete in hot weather than there are in cold weather, therefore emphasizing the importance of quality practices. Refer to ACI 305R, "Hot Weather Concreting."

The following list presents some hot weather rules-of-thumb:

1. *Concrete sets and hardens faster. This means that concrete must be deposited, consolidated and finished quickly if the concrete temperature is high.*
2. *On warm windy days, plastic shrinkage cracks are likely to form unless precautions are taken.*
3. *Unless curing begins immediately, the surface of the concrete is likely to dry out, resulting in cracking or weakening of the concrete surface.*

In cold weather, if concrete does not freeze before its strength reaches at least 500 psi (3.4 MPa), it will eventually be stronger than similar concrete cast in warm weather. Setting time is delayed in cold weather and concrete gains strength slowly, but most properties

STANDARD

COMMENTARY

- The air temperature is not greater than 50 degrees F (10 degrees C) for more than one-half of any 24-hour period.

Concrete that freezes before its compressive strength reaches at least 500 psi (3.4 MPa) shall be discarded. Suitable precautions shall be taken in cold weather to prevent concrete from freezing. Such precautions may include:

- a. Heating the mixing water, but not above 180 degrees F (82 degrees C).
- b. Avoid using frozen aggregates.
- c. Heat forms prior to and after casting.
- d. If concrete does not freeze and no heat is applied, do not strip the product until adequate strength is attained.
- e. Monitor concrete temperatures during curing.

of concrete are improved. Because of the slow strength gain, curing with heat is often used. Refer to ACI 306R, "Cold Weather Concreting."

The average daily air temperature is the average of the lowest and the highest temperatures occurring during the period from midnight to midnight. As such, cold weather, as defined by ACI 306R, generally starts during the fall and continues until spring.

4.4.8 Plant Requirements:

1. Plant equipment used to transport concrete shall be inspected daily by the plant QC Inspector to ensure that concrete does not segregate or become contaminated. The QC Inspector shall perform and document a spot-check of the concrete transport, placement, consolidation, and finishing of each product line.
2. Workers shall be properly trained in the use of internal and external vibrators.
3. The plant shall maintain written procedures for concreting during hot and cold weather conditions, if applicable, as required in Section 1.1.2.

4.5 CURING CONCRETE

Internal concrete temperature monitoring criteria is established to help prevent Delayed Ettringite Formation (DEF). Further guidance is also given in the commentary by including five concrete mix design options that will mitigate for both Alkali Silica Reaction (ASR) and DEF.

4.5.1 General

Effective curing shall begin as soon as possible, prior to the formation of shrinkage cracks, and no longer than 4 hours after casting the precast concrete unit. The concrete shall not exceed 150 degrees F (65 degrees C). If approved measures to prevent delayed ettringite formation (DEF) are employed concrete temperatures shall not exceed 160 degrees F (71 degrees C). Monitor a minimum of once every 3 months the maximum concrete temperature in the highest internal concrete temperature location(s). The highest internal concrete temperature shall be determined by testing. Verification testing and monitoring shall consider all product sizes, mix designs, and curing conditions when selecting the minimum amount of necessary testing.

If concrete is cured with steam or radiant heat, curing procedures must be established and records kept of the temperature of the concrete and environment during the curing period (see 4.5.3).

Concrete hardens by the chemical reaction between cement and water, a process called hydration. Hydration continues for years provided moisture is present, but if concrete dries, hydration stops and concrete stops gaining strength. Like most chemical reactions, hydration proceeds faster at warm temperatures than at cooler temperatures. Curing of concrete means providing the proper environment for hydration to occur. Thus the necessary factors are moisture, time and temperature. Concrete can be cured by covering it with damp burlap, ponding the surface, steam, or by other means of preventing moisture within the concrete from evaporating. Alternate wetting and drying during the first few days after casting is almost as bad as no curing.

Research has shown that if concrete temperatures during curing are kept below 158°F problems from Delayed Ettringite Formation (DEF) can be avoided.

When testing for the highest internal concrete temperature location(s) the

temperature monitoring device should be located in the hottest section (usually largest mass) of the product. Concrete mix designs that generate the highest internal concrete temperatures such as mixes containing accelerating admixtures, corrosion inhibitors, Type III cement, or heated aggregates should be selected. Product close to any heat source should also be selected.

Mix designs to prevent DEF should include the replacement of cement with a Supplemental Cementitious Material (SCM). The SCM's most commonly used for DEF mitigation include fly ash, slag cement, silica fume, and metakaolin. Mix designs that contain SCM's in the proper replacement percentages inherently have lower peak concrete temperatures, and mitigate DEF, even at concrete temperatures above 158°F.

DEF and ASR mitigating mix design options include but are not limited to:

Option 1. *Replace 20% to 45% of the cement with Class F fly ash.*

Option 2. *Replace 35% to 50% of the cement with slag cement.*

Option 3. *Replace 35% to 50% of the cement with a combination of Class F fly*

STANDARD

COMMENTARY

ash, slag cement, metakaolin, or silica fume; however, no more than 35% may be fly ash, and no more than 10% may be silica fume.

Option 4. *Use Type IP, Type IS, or Type IT cement.*

Up to 20% of a Type IP, Type IS, or Type IT cement may be replaced with Class F fly ash, slag cement, or silica fume. Use no more than 10% silica fume in the final cementitious material mixture if the Type IT cement contains silica fume, and silica fume is used to replace the cement.

Option 5. *Replace 35% to 50% of the cement with a combination of Class C fly ash and at least 6% of silica fume, or metakaolin. However, no more than 35% may be Class C fly ash, and no more than 10% may be silica fume.*

Mix design options containing ultra fine fly ash (UFFA) or modified Class F fly ash (MFFA) may be acceptable with proper testing documentation.

The PCA Manual 16th Edition 'Design and Control of Concrete Mixtures states: Ettringite is a normal reaction product during the hydration of cement. When concrete is exposed to temperatures in excess of 158°F, substantial

amounts of sulphates are bound in an unusual form in the cement matrix, and the normal formation of ettringite is stopped. At later ages and in the presence of moisture, the bound sulphates desorb back into solution and react with calcium monosulfoaluminates to form ettringite. This delayed formation of ettringite can exert pressures on the concrete because it forms in a limited space and under supersaturation. Since concrete is rigid and if there are insufficient voids to accommodate the ettringite volume increase, expansion and subsequent cracking can occur. In addition, some of the initial ettringite may be converted back to monosulfoaluminate at high temperatures and upon cooling revert back to ettringite. Because ettringite takes up more space than monosulfoaluminate from which it forms, the transformation is an expansive reaction.

4.5.2 Curing by Moisture Retention

Preventing moisture from evaporating from the exposed surfaces of precast concrete elements shall be considered an effective method of curing, provided the concrete temperature is above 55 degrees F (13 degrees C). If the concrete temperature is lower than 55 degrees F (13 degrees C) but above 35 degrees F (2 degrees C), and moisture evaporation is prevented, the curing period must be extended. Forms shall be considered effective in preventing evaporation from the contact surfaces. The use of a membrane-curing compound applied

Covering the exposed surfaces of products while in forms immediately after casting is often adequate to assure that hydration will continue. Covers made of polyethylene sheets should be at least 6 mils (0.15 mm) thick. There should be no

thick enough to prevent evaporation of moisture shall also be considered an effective curing method.

Local regions and ambient temperature and humidity conditions will influence the need for curing with heat combined with moisture.

air circulation beneath the cover. Curing compounds should be applied at a rate not to exceed about 200 square feet per gallon (5 square meters per liter).

Laboratory cured cylinders may not reflect in-place strength of concrete unless a controlled curing environment is provided for the precast product. Concrete Maturity Testing provides a good indication of in-place strength.

4.5.3 Curing with Heat and Moisture

Concrete shall not be subjected to steam, hot air, or other means of accelerated curing until after the concrete has attained its initial set. This does not include chemical admixtures. Record the initial set of the concrete (ASTM C403) a minimum of once quarterly when heat-curing. Steam, if used, shall be applied within a suitable enclosure that permits free circulation of the steam. If hot air is used for curing, precautions shall be taken to prevent moisture loss from the concrete. These requirements do not apply to products cured with steam under pressure in an autoclave.

The ambient curing temperature (for both wet-cast and dry-cast products) shall be monitored and documented a minimum of once per week, when employing accelerated curing with heat and moisture. The plant shall then establish an ambient curing cycle that ensures that the ambient curing temperature does not exceed 150 degrees F (65 degrees C) unless measures to prevent delayed ettringite formation (DEF) are employed. In addition, the rise in ambient curing temperature shall be limited to a maximum of 40 degrees F (22 degrees C) per hour.

Gas-fired heaters shall not be used to directly heat exposed concrete surfaces due to the risk of severe carbonation of the concrete.

This section applies to curing with heat and moisture for the purposes of accelerating the strength gain of the concrete, not the maintenance of form and/or ambient temperatures at relatively low temperatures. Accelerated curing heat should not be applied to concrete until about 30 minutes after initial set of the concrete. Initial set can be determined in accordance with ASTM C403, "Standard Test Method for Time of Setting of Concrete Mixtures by Penetration Resistance." If heat is applied too soon, concrete can be damaged permanently. It is important that the heat does not dry out the surface of the concrete, otherwise the concrete near the surface will be weak and chalky. Concrete cured with heat will gain strength rapidly, but long-term strength gains are reduced.

4.5.4 Plant Requirements:

1. Verify concrete does not exceed maximum temperature, per Section 4.5.1, for the highest heat generating mix designs, largest concrete mass, and hottest curing conditions.
2. If products are cured with heat and moisture in order to accelerate the strength gain, the ambient curing temperature shall be monitored during the curing period at least once per week. Temperature records shall be maintained in the plant records.
3. If heat curing is used, the necessary initial-set period shall be determined, per Section 4.5.3.
4. Products cast outdoors or in dry conditions shall be protected from moisture loss by application of a curing compound, moist curing or impervious sheeting.
5. The QC Inspector shall inspect curing of products and exposed surfaces of stripped products for evidence of plastic cracking. Damage shall be documented.

4.6 STRIPPING PRODUCTS FROM FORMS

4.6.1 Minimum Strength Requirement

Products shall not be removed from the forms until the concrete reaches the designed compressive stripping strength. If no such requirement exists, the plant shall define product-specific minimum stripping strengths that must be obtained prior to stripping. These requirements shall be defined in the plant-specific quality control manual discussed in Section 1.1.2. In addition, one-day, or stripping compressive strength tests shall be performed for each mix design at least quarterly in order to confirm that adequate stripping strengths are being attained. These requirements do not apply to dry-cast and/or machine-made products.

Some products, such as those that serve a structural function, are required to have a certain strength level at the time of stripping to assure adequate bond between the concrete and reinforcement, and to minimize stresses in the product.

4.6.2 Product Damage During Stripping

Products damaged during stripping shall be evaluated by qualified plant personnel to determine if repairs are necessary, and if so, what repair is required before shipping.

A record of any major damage and the repairs shall be kept on file with the final inspection report, as required in Section 4.8.5.

See 4.7.2 for definition of “major repairs.”

The “qualified plant personnel” should be completely knowledgeable about the end use of the product, including its environment, and should know which types of repairs are feasible. It is advisable to learn the cause of the damage so that management can take action to minimize similar damage in the future.

4.6.3 Formed Surfaces

Formed surfaces shall be considered satisfactory if they are relatively free of air voids and honeycombed areas, unless the surfaces are required by the design to be finished.

A minor number of voids in the surface are quite normal. Filling of those voids is done for cosmetic purposes and usually only when required by specifications. For special surface finishes, it is recommended that a mockup panel is made and accepted by the purchaser prior to production. The mockup

STANDARD

COMMENTARY

4.6.4 Post-Pour Inspection

After products are stripped from the forms, they shall be inspected for conformance with the design. Items to be repaired shall be classified as “major” or “minor” defects, or as honeycombed areas. Post-pour inspection records shall be kept in the files for a minimum of three (3) years.

See 4.7.1 and 4.7.2 for “minor” and “major” repairs.

should be kept until the project is complete.

Post-pour inspections are useful for managing quality. Recurring major defects require decisive action by management. Major defects in small products usually means rejection of the products, while major defects of large products are generally costly and often disrupt the orderly operation of the plant. It is generally easiest to make repairs while the product is young, but repairs should not begin until appropriate techniques are developed for making the repair.

Each producer is required to use a standard post-pour inspection checklist to record dimensions, deviations – damage, etc. This checklist template is to be included in the plant-specific QC Manual.

The American Concrete Institute, Committee 117, has established industry standards for dimensional tolerances. These tolerances and the tolerances prescribed in the Appendix B of this Manual should be considered as a standard specification unless otherwise specified in the contract documents.

4.6.5 Plant Requirements:

A post-pour inspection shall be made of each product. The inspections shall document any damage, excessive bugholes or honeycombing, poor dimensional tolerances, or other problems such as exposed reinforcing. A mark shall be made on the product indicating whether it is acceptable, requires repair, or it has been rejected.

4.7 REPAIRING CONCRETE

4.7.1 Repairing Minor Defects

Defects not impairing the functional use or expected life of a precast concrete product shall be considered minor defects. Minor defects may be repaired by any method that does not impair the product.

When honeycombed areas are to be repaired, all loose material shall be removed and the areas cut back into essentially horizontal or vertical planes to a depth at which coarse aggregate particles break under chipping rather than merely being dislodged. Proprietary repair materials shall be used in accordance with the manufacturer's instructions. If a proprietary repair material is not used, the area shall be saturated with water and, immediately prior to repair, the area shall be damp, but there shall be no excess water. A cement-sand grout or an approved bonding agent shall be applied to the chipped surfaces, followed immediately by consolidating an appropriate repair material into the cavity.

It is assumed that qualified personnel will judge which defects are minor and which are major. The person making the judgment must be thoroughly familiar with the functional use of the product, including the environment in which the product will function. Behavior of concrete in the product and in that environment must be known. Repairs of minor defects are essentially cosmetic, (e.g., the product would behave as intended without the repairs)

4.7.2 Repairing Major Defects

Defects in precast concrete products that impair the functional use or the expected life of products shall be considered major defects. Unless major defects are repaired the product shall be rejected. Major defects shall be evaluated by qualified personnel to determine if repairs are feasible and if so, to establish the repair procedure. Proper repairing procedures and curing shall be inspected.

Repairs should be made as soon as feasible after the defect is noted so that differential shrinkage between the original concrete and the repair concrete is minimized. Concrete used in repairs of major defects should be essentially the same as the original concrete except that the repair concrete should contain less water. Also, the maximum size of aggregate should be as large as possible but not greater than one-half the minimum dimension of the repair. The procedures outlined in Sec. 4.7.1 can be used to repair the product. The repair concrete should become an integral part of the product with no delaminations or cracks.

4.7.3 Inspection of Repairs

Products that require repairs of honeycombed areas or major repairs shall be inspected while repairs are made. A record of any major repairs shall be documented and filed with the final inspection report for that product.

Even minor repairs should be inspected to assure that no damage has been done to products being repaired. The inspection records for repairs of major defects should indicate any deviations from the established repair procedure.

4.7.4 Plant Requirements:

1. The plant shall have documented procedures for repair of damaged products, including procedures for repair of honeycombing, excessive air voids, and minor and major defects. The procedures shall list acceptable repair products to be used.
2. After repairs are completed and inspected, a mark shall be made on the product indicating that it is acceptable, or that it is rejected.

3. QC Inspector shall perform checks of repairs.
4. Major repairs shall be documented.

4.8 MARKING, STORAGE, AND SHIPMENT OF PRODUCTS

4.8.1 Product Marking

Products shall be marked as required by project specifications. Unless otherwise prevented by product specifications or aesthetic reasons, products shall be prominently marked indicating conformance with this manual. For plants participating in the NPCA Plant Certification Program this mark shall be the "NPCA Certified Plant" symbol.

It is extremely helpful to include the date of manufacture in the product marking in order to facilitate the tracking of product and raw materials.

4.8.2 Storage Areas

Areas used for storage of products shall be firm enough and level enough to avoid causing damage to stored products.

It is good practice to place in storage only products that are ready for shipment, thus minimizing product handling. Also, repairs are generally controlled better and done more effectively in a designated area than in a storage yard. Thus, storage areas should be arranged so that products will not be damaged and are readily accessible.

4.8.3 Storage of Products

Products shall be stored in a manner that will minimize damage caused by uneven bearing, improperly located dunnage blocks, stacking products too high or difficulty in handling.

Products should preferably be stored on level surfaces. Bearing surfaces should be large enough to prevent chipping or fracturing of the product.

Reject product that cannot be adequately repaired shall be uniquely marked such that plant personnel can easily identify it as reject. Reject product shall be stored separately from normal stock.

4.8.4 Shipment of Products

Trucks and other conveyances used to transport precast concrete products from the plant to the location designated by the customer shall be equipped and maintained to deliver those products without damaging them to the extent that they must be repaired or rejected.

Records shall be kept for at least a year of all products and accessories shipped on each load. The record shall indicate which items, if any, were damaged when delivered.

Trucks and other delivery equipment should be inspected periodically to ensure products will be delivered without damage. Copies of delivery receipts are normally kept for billing and inventory purposes. They should also be reviewed by management to monitor the number of products damaged and how they were damaged, so that appropriate action can be taken to minimize future damage.

4.8.5 Final Inspection

Prior to shipment, products shall be inspected to assure design conformance and proper identification. The precast plant shall establish a procedure for sampling and inspecting products that are shipped in bulk. Products that are handled individually during shipment to the project site shall be inspected individually. Inspections shall be documented.

Products not conforming to requirements shall be clearly labeled and the defects noted on the inspection report. Only products conforming to the requirements shall be shipped. The purchaser may, at their discretion, waive certain requirements that are minor in nature. Management shall be notified of defects prior to shipment so that action can be taken.

Many precast products should be inspected individually, but some products such as modular pavers and transformer bases can be inspected in groups.

Management should review inspection reports prior to shipment in order to minimize sub-quality products leaving the yard.

4.8.6 Plant Requirements:

1. Storage areas shall be maintained firm and level such that products are not damaged during handling and do not sink into the ground.
2. Products shall be stored to minimize damage.
3. The QC Inspector shall inspect the storage area and the stored product daily.
4. A final inspection of products prior to shipment shall be made. This inspection shall be documented in the plant records. The inspection shall include verification that the product conforms to project specifications, plans and other contract documents, contains the proper post-pour inspection markings, and that repairs have been made and inspected where needed.

CHAPTER 5 - QUALITY CONTROL OPERATIONS

5.1 SUMMARY OF REQUIRED RECORDS

Unless otherwise specified in this manual, all required documentation and records shall be kept for a minimum of three (3) years. Plants initially entering the NPCA Plant Certification Program shall have a minimum of 30 calendar days of records prior to their initial audit. Thereafter, all required documentation and records shall be kept on file until the applicable minimum retention time has elapsed.

It is suggested that all of the required records be maintained in a central location at the plant. In addition, it is very helpful if the records are organized in a similar sequence as the sections of this manual.

5.1.1 Raw Material & Test Records

Records of incoming raw materials and certifications, credentials of third party personnel and calibration records for third party and/or plant owned test equipment shall be kept by the precast plant for a minimum of three (3) years. These records shall at a minimum include the following:

Test records are useful in verifying that materials used in manufacturing precast concrete products conformed to the product specifications. They are useful in isolating problems that occur either soon after a product is cast or long after a product has been in service. Accessories are design items included in the products but do not include the wire, chairs, clips.

- a. Cement mill test reports and certificates
- b. Aggregate certifications and reports
- c. Mix water potability or suitability tests
- d. Chemical admixture and supplementary cementitious material test reports and certifications
- e. Reinforcement mill certifications
- f. Fiber-Reinforcement certification
- g. Joint sealant, gasket and connector supplier certifications and test reports
- h. Accessories supplier certifications and reports
- i. Batching records or ready-mixed concrete delivery tickets
- j. Buy America Provisions as required by specific project
- k. Certificate of compliance for all lifting inserts
- l. Laboratory Accreditation or ACI certificates and test equipment calibration records of any third-party firm or testing agency.

Records that require annual certifications and/or test reports shall be dated not more than one year at the end of the month from the date of the last test or certification.

Example: Aggregates were certified by the quarry to meet ASTM C33 on March 15 of the current year. Aggregates would need to be recertified by the quarry no later than March 31 of the following year.

5.1.1.1 Independent Third Party Testing Laboratory

Third party laboratories may be accredited to ISO/IEC 17025, or the applicable AASHTO laboratory accreditation.

Plants that employ a third party laboratory for testing and/or calibration services shall, at a minimum, obtain the credentials of personnel performing the testing and the calibration records for the equipment used.

Technicians from a third party laboratory performing plastic concrete testing at the precast facility shall provide a current ACI Field Technician Level I certification. Technicians from a third party laboratory performing compressive strength testing and/or aggregate testing shall provide an appropriate and current ACI certification for the testing being performed along with a current equipment calibration certificate.

Plants subject to owner specific certification and testing requirements shall have appropriate documentation on file for auditor review.

5.1.2 Work Orders and Product Drawings

Work orders for each project shall be kept by the precast plant until the project is completed. Product drawings shall be kept by the precast plant for at least three (3) years.

Most work orders are internal documents and as such need not be kept for quality control purposes. However, product drawings are important documents that may be useful in product evaluation years after the product has been in service. Precast plants that make custom products should have a procedure for keeping drawings, electronic scans, microfilms of the drawings, or other methods of retaining product drawings.

5.1.3 Equipment Calibration Records

Records for calibration of equipment shall be maintained so that the equipment operator has ready access to the records. Current calibration stickers shall be attached to and prominently

displayed on all equipment requiring calibration. All of the following equipment shall be calibrated a minimum of once per year. Current calibration reports shall be dated not more than one year at the end of the month from the date of the last calibration or certification.

- Concrete batching scales
- Water meters
- Admixture batching equipment
- Concrete compression test machines
- Portable scales
- Air meter
- Density (Unit weight) bucket
- Rebound hammer (if used)
- Temperature recorders and clocks
- Three-edge bearing test machines
- Pipe and manhole measuring devices (i.e., go-no-go gages)
- Vacuum and hydrostatic testing equipment

Calibration of batching scales, compression testing machines and three-edge bearing testing machines shall be performed by an independent, third-party calibration company. All other calibrations shall be performed in-house, by the supplier, or by an independent, third-party calibration company.

5.1.4 Aggregate and Concrete Test Records

Records of tests for aggregate gradation, organic impurities in aggregates, and aggregate moisture content shall be kept for a minimum of three (3) years. Records of tests of concrete temperature, slump, air content, density (unit weight), and compressive strength shall be kept by the precast plant for a minimum of three (3) years.

Unless records of aggregate and concrete tests are identified in such a manner that make it possible to determine which products were made with the materials tested, they are not very useful. A simple orderly method of relating such records to specific products can make the test reports valuable.

5.1.5 Concrete Batching Reports

Daily reports of actual concrete mix proportions for each mix used and quantities of produced concrete shall be documented and maintained on file by the precast plant for a minimum of three (3) years.

A method of identifying which products are made from each batch should be used in order to make the records useful. Plants should backup electronic

STANDARD

COMMENTARY

5.1.6 General Plant and Product Inspection Records

QC Inspector inspection reports and product inspections records shall be maintained on file by the precast plant for a minimum of three (3) years.

batching files a minimum of weekly.

Records of final inspections of products are only useful from the standpoint that they show the products were judged to be of adequate quality when they left the plant. Thus, they are most useful as a plant management tool.

5.1.7 Plant Requirements:

Maintain the required records in an easily accessible and well-organized file. Documentation shall be easily retrievable and indexed to specific products by date or piece number. Records shall be maintained for the minimum duration.

5.2 AGGREGATE TESTING

5.2.1 Aggregate Gradation

Gradation tests shall be made for each 1,500 tons (1,350 metric tons) of fine aggregate and each 2,000 tons (1,800 metric tons) of coarse aggregate by either the aggregate supplier or by the precast plant. Gradation tests shall be performed in accordance with ASTM C136, "Standard Test Method of Sieve Analysis of Fine and Coarse Aggregates."

Gradation tests are used to determine if aggregates conform to applicable specifications. Concrete mixes are generally designed based on aggregates having specific gradations (particle size distributions). One of the reasons for performing aggregate gradation tests is to note changes in gradation so that concrete mixes can be adjusted, or perhaps they should be redesigned. A rule of thumb is that a change in the fineness modulus of the fine aggregate of 0.20 or more indicates that an adjustment or redesign should be made. Large variations in coarse aggregate gradations may warrant adjustments to the

concrete mix. Changes in the amount of material passing the No. 50 (0.300 mm) sieve often indicate changes in workability and in the bleeding characteristics of the concrete.

5.2.2 Moisture Content

5.2.2.1 Conventional and/or Dry-Cast Concrete

For conventional and/or dry-cast concrete, aggregate surface moisture content (i.e., water in excess of that absorbed by the aggregates) shall be determined at least once per day in accordance with ASTM C70, "Standard Test Method for Surface Moisture in Fine Aggregate," by alternate methods such as moisture meters or probes, or by ASTM C566, "Standard Test Method for Total Evaporable Moisture Content of Aggregate by Drying." Drying aggregate using a microwave or hot plate shall be permitted in addition to using an oven.

It is very important to know the moisture content of the aggregate in order to determine the water content in the concrete batch. This information is useful for determining and making adjustments to mix designs as well.

For conventional and/or dry-cast processes when aggregate bins fitted with moisture probes or meters, aggregate surface moisture content shall be determined a minimum of once per week in order to validate moisture probe accuracy and performance.

5.2.2.2 Self-Consolidating Concrete

For SCC processes when aggregate bins are fitted with moisture probes or meters used with automatic mixing water adjustment systems, the aggregate surface moisture content shall be determined a minimum of once per week in order to validate moisture probe or meter calibration. Moisture tests shall be performed in accordance with ASTM C70, "Standard Test Method for Surface Moisture in Fine Aggregate," or by ASTM C566, "Standard Test Method for Total Evaporable Moisture Content of Aggregate by Drying." Drying aggregate using a microwave or hot plate shall be permitted in addition to using an oven. Samples for moisture tests shall be taken as close as possible to the area where the probe is located.

Since SCC concrete is very moisture sensitive, precise control of the water content is essential. Verifying aggregate surface moisture will allow for necessary adjustments in mix water as the moisture content of the aggregates changes throughout the day. Slump Flow and VSI testing will only confirm whether a SCC mixture is within spec and become necessary for this confirmation if moisture tests are not performed on a regular basis (every 3 batches).

For SCC processes made without moisture probes or meters and automatic mixing water adjustment systems, the aggregate surface moisture content shall be determined at least once a day prior to making the first SCC batch and then once every four hours of elapsed time after the first batch, while SCC is being

mixed. Moisture tests shall be performed in accordance with ASTM C70, "Standard Test Method for Surface Moisture in Fine Aggregate," or by ASTM C566, "Standard Test Method for Total Evaporable Moisture Content of Aggregate by Drying." Drying aggregate using a microwave or hot plate shall be permitted in addition to using an oven. In addition, Slump Flow and VSI tests shall be performed in accordance with section 5.3.1.2 for every three batches of SCC produced (This is to ensure that moisture fluctuations of aggregates are accounted for correctly). In lieu of this additional Slump Flow and VSI testing, moisture tests may be performed as specified in this section every three batches.

In situations where the plant is producing SCC, the plant should consider performing unit weight of the mix in addition to slump flow and VSI as another verification of proper mix proportioning.

5.2.3 Plant Requirements:

Records of aggregate gradations, deleterious substance and aggregate moisture tests shall be maintained in the plant records.

5.3 CONCRETE TESTING *

For all concrete testing, plant personnel shall take corrective action whenever the test result does not fall within the established acceptable tolerance range from the documented initial mix qualification.

** Critical Requirement – plants participating in the NPCA Plant Certification Program must receive a minimum passing grade, as shown on the grading schedule, for this entire section and others designated as Critical Requirements, when applicable.*

5.3.1 Slump, Slump Flow, and Visual Stability Index

5.3.1.1 Slump

A slump test of fresh concrete of each mix design shall be performed for each 150 cubic yard (115 cubic meters) of concrete, or once a day, whichever comes first. Slump tests shall be performed in accordance with ASTM C143, "Standard Test Method for Slump of Hydraulic-Cement Concrete." SCC, no-slump, or dry-cast concrete does not need to be tested for slump.

5.3.1.2 Slump Flow and Visual Stability Index

For SCC mixtures, slump flow and Visual Stability Index (VSI) tests of fresh concrete of each mix design shall be performed each day by testing the first batch of SCC as defined by the initial mix qualification process. Reject the concrete if the upper specification limit is exceeded. If the slump flow test result is less than the lower production range limit reject the concrete unless the mixture has been approved for vibration and is subsequently

Producers using SCC shall follow applicable ASTM test methods for air content, unit weight, and casting compressive strength cylinders. Filling in lifts and rodding are not required when using SCC.

STANDARD

COMMENTARY

vibrated. Thereafter, slump flow and VSI testing shall be performed as follows:

- When changing mix designs
- When changing raw materials,
- and
- As required in Section 5.2.2.2

Slump flow and VSI tests shall be performed in accordance with ASTM C1611 “Standard Test Method for Slump Flow of Self-Consolidating Concrete”

The slump test is used to determine the consistency of fresh concrete and the uniformity of concrete from batch-to-batch. If the batch weights of cement, water, and aggregates are reasonably correct, changes in slump are probably due to changes in aggregate moisture or in dispensing of admixtures. However, slump variations can also occur because of changes in aggregate gradations, temperature and air content.

The air content of an SCC mix can affect the desired properties of the mixture and it is recommended that the air content be tested regularly with the Slump Flow and VSI.

5.3.2 Temperature

The temperature of fresh concrete of each mix design shall be measured when slump or air content tests are made and when compressive test specimens are made. The measured concrete temperature shall be recorded together with other fresh concrete test data. Concrete temperature testing shall be performed in accordance with ASTM C1064, “Standard Test Method for Temperature of Freshly Mixed Portland Cement Concrete.”

Temperature of fresh concrete affects a number of properties of concrete. Warm concrete sets faster than cool concrete. Warm concrete gains strength faster than cool concrete, but the strength at later ages will be lower than that of cool concrete.

Knowledge of the temperature of fresh concrete permits the batch plant operator to adjust mixes and allows the concrete foreman to better allocate workmen. Also, warm concrete tends to dry faster so curing of warm concrete is even more

important than curing of cool concrete.

5.3.3 Density (Unit Weight)

Tests for density (unit weight) of fresh concrete of each mix design shall be performed a minimum of once per week or every 150 cubic yards, whichever occurs first, to verify the yield of batch mixes. Density tests shall be performed for each 100 cubic yards (75 cubic meters) of lightweight concrete or once per month, whichever occurs first. Tests shall be performed in accordance with ASTM C138, "Standard Test Method for Density (Unit Weight), Yield, and Air Content (Gravimetric) of Concrete." Unless otherwise specified density (unit weight) does not need to be tested for dry-cast concrete.

The density (unit weight) of concrete is often specified for products made of lightweight concrete. If the density is higher or lower than the specified limits, adjustments should be made to the mix to increase or decrease the density. After adjustments are made, the density should again be measured. The best method for checking the yield of concrete (the actual volume of concrete produced from quantities of materials, which theoretically are needed for one cubic yard or one cubic meter of concrete) is by dividing the total weight for a cubic yard or a cubic meter (theoretical) by the density of the concrete.

5.3.4 Air Content

For all wet-cast concrete of fresh concrete of each mix design containing air-entrainment, tests for air content shall be made for each 150 cubic yards (115 cubic meters) of concrete, but not less often than once each day. For all wet cast concrete of fresh concrete of each mix design made without air-entrainment, tests for air content shall be made whenever compressive strength specimens are cast, but not less often than once per week. Air content shall be determined by either the pressure method, ASTM C231, "Standard Test Method for Air Content of Freshly Mixed Concrete by the Pressure Method," or the volumetric method, ASTM C173, "Standard Test Method for Air Content of Freshly

Concrete is air-entrained not only for its improved resistance to freezing and thawing but also because air-entrainment reduces bleeding and segregation. For frost resistance, air contents given in Table 3.1.3 should be used. Air contents higher than the values given in that table

STANDARD

COMMENTARY

Mixed Concrete by the Volumetric Method.” A density (unit weight) test, performed in accordance with ASTM C138, may be substituted for ASTM C231 or ASTM C173 after a correlation between air content and density (unit weight) has been established. Air content does not need to be tested for dry-cast concrete.

will reduce concrete strength dramatically. Air contents lower than the tabulated values will not provide adequate frost resistance. However, if the air contents are slightly lower than the tabulated values, the concrete will benefit from reduced segregation and bleeding as compared to a non air-entrained concrete.

For normal-weight concrete, either the pressure method or the volumetric method can be used, but the pressure method is generally preferred because the test can be done more quickly and more easily. For lightweight concrete, the volumetric method is generally required and much more accurate than the pressure method.

An air indicator is a small hand-held device, which utilizes a thimbleful of material passing a No. 10 (2.0 mm) sieve. It can be done very quickly and gives a reasonable indication of air content, provided it has been calibrated by comparing a number of air indicator measurements with results of air-meter tests for each concrete mixture.

5.3.5 Compressive Strength

5.3.5.1 Wet Cast

Compressive strength cylinders shall be made in accordance with ASTM C31, "Standard Practice for Making and Curing Concrete Test Specimens in the Field." Specimens shall be cured in a manner similar to the curing of the concrete products represented by the specimens, unless otherwise required by the project.

The main reason for making and testing compressive strength specimens is to determine if the concrete strength conforms to the requirements. Strength tests are also useful at early ages to evaluate curing methods and to determine uniformity of concrete. Making and testing 4 x 8-inch cylinders is easier and costs less than using 6 x 12-inch specimens so the use of 4 x 8-inch cylinders is encouraged unless specifications prohibit their use. Use of 4 x 8-inch cylinders has advantages that specimens are smaller, are easier to make, use less concrete, are easier to handle and require less storage space.

5.3.5.2 Machine-Cast or Dry-Cast

For machine-cast and/or dry-cast concrete products, test cylinders can be vibrated or cores cut from the product. Test cylinders shall be vibrated in the same method as the product they represent or fabricated according to the applicable section of ASTM C497.

Often times, dry-cast equipment is equipped with test cylinder holding devices that enable specimens to be vibrated the same as the product. Sometimes cores or cubes cut from products after the concrete has hardened are required as test specimens. For small products, the entire product might be used as a specimen and tested in compression. Whatever the specimen, a "standard" test procedure should be established so that results of tests

5.3.5.3 SCC

Compressive strength cylinders shall be made in accordance with ASTM C1758, "Standard Practice for Fabricating Test Specimens with Self-Consolidating Concrete." Specimens shall be cured in a manner similar to the curing of the concrete products represented by the specimens, unless otherwise required by the project.

conducted at different times can be correlated.

5.3.5.4 Compressive Strength Specimens

At least four compressive strength specimens shall be made for each 150 cubic yards (115 cubic meters) of concrete of each mix or once per week, whichever occurs first. Two specimens shall be tested at or before 7 days and, if the specified design strength has not been met at that time, the other two shall be tested at or before 28 days, or at the age specified by design. Specimens made in cylinder molds shall be tested in accordance with ASTM C39, "Standard Test Method for Compressive Strength of Cylindrical Concrete Specimens." Cubes or cores cut from products shall be tested in accordance with ASTM C42, "Standard Test Method for Obtaining and Testing Drilled Cores and Sawed Beams of Concrete."

5.3.5.5 Cores

As an alternate to the use of test cylinders, or If cylinder tests fall below the specified value, three cores may be used **from the same date of production and mix design** to determine concrete strength. Cores shall be obtained and tested in accordance with ASTM C42.

Depending upon the level of consolidation, core samples from the bottom of sections may result in higher than average strength levels. Care should be taken to avoid cutting reinforcing bars where cores are obtained. Reinforcement in cores can affect the strength, depending on the quality and orientation of the reinforcement. The average value for cores of 85% of the specified strength is realistic since cores will generally yield lower strength results than test cylinders because of differences in size of specimens, conditions for obtaining samples and curing.

5.3.5.6 Calibrated Impact Hammer

If the concrete strength is lower than specified and the compressive strength test specimens have been depleted, a calibrated impact rebound hammer may be used to indicate strength of the concrete after additional curing of the concrete. The rebound hammer should not be used for acceptance or to determine structural adequacy but to compare concrete strength at different locations or for quality control purposes. Impact rebound hammer shall be used in accordance with ASTM C805, "Standard Test Method for Rebound Number of Hardened Concrete."

Impact rebound hammers are useful devices but they should be calibrated periodically. One way of calibrating the hammer is to compare the rebound number on products with the compressive strengths of specimens representing the concrete in the products. Rebound numbers on products should be obtained at the same age as the age at which the compressive strength specimens are tested.

5.3.6 Plant Requirements:

1. Persons conducting QC tests shall be properly trained to perform the tests (see Section 1.1.3).
2. Proper ACI Field Technician Grade 1 test techniques and procedures shall be demonstrated for slump, temperature, density (unit weight), air content, and fabrication of compressive strength cylinders during the NCPA audit.
3. Track the number of tests on each neoprene compression test pad, if used.
4. If concrete testing is performed by an outside testing agency, the testing shall be conducted at the point of placement and the plant shall obtain the ACI certificate of the tester along with calibration records of equipment used. Obtaining this documentation from the supplier insures that the personnel performing the tests have been properly trained and equipment used has current calibration.
5. Testing of concrete compressive strength cylinders by third parties is not required to be performed on the plant premises. Plants using third party suppliers for compressive strength testing shall obtain copies of the testers ACI certificate and current equipment calibration certificate.

See table 5.3.6 a, b, and c for required minimum frequency of Quality Control operations.

Table 5.3.6 a
Frequency of Quality Control Operations
Materials Certifications and Equipment Calibrations

Section in NPCA QC manual	Item	Each Shipment	Each 1,500 Tons (b)	Each 2,000 Tons (c)	Each 200 CY (d)	Each Pour	Each 150 CY (e)	Each 100 CY (f)	Daily	Weekly	Monthly	Annually	Remarks
2.1.1	Cement mill test report	X ^(a)											
2.2.1	Reinforcing bars mill certificates	X ^(a)											
2.2.2	Reinforcing wire mill certificates	X ^(a)											
2.2.3	Bar mats and welded wire reinforcement mill certificates	X ^(a)											
3.1.4	Admixture dosing equipment certification											X ^(a)	
3.2.4	Weigh batch scales calibration											X	
5.1.1.j	Certificate of Compliance for all lifting inserts											X	
5.1.1.k	Current copy of ACI Certificate of Third Party Tester and Equipment Calibrations											X	

Notes:

- (a) Items may be furnished by the raw material supplier
- (b) 1,350 cubic meters
- (c) 1,800 cubic meters
- (d) 150 cubic meters

Table 5.3.6 b
Frequency of Quality Control Operations
Production Practices

Section in NPCA QC manual	Item	Each Shipment	Each 1,500 Tons	Each 2,000 Tons	Each 200 CY	Each Pour	Each 150 CY	Each 100 CY	Daily	Weekly	Monthly	Annually
4.1.2	Housekeeping								X			
4.1.3	Forms cleaned of build-up					X						
4.1.5	Dimensional checks of machine-made products								X			
4.3.5	Pre-pour inspection					X						
4.6.4	Post-pour inspection					X						
4.8.3	Final inspection	X										

Table 5.3.6 c
Frequency of Quality Control Operations Aggregates and Concrete

Section	Item	Each Shipment	Each 1,500 Tons (a)	Each 2,000 Tons (b)	Each 200 CY (c)	Each Pour	Each 150 CY (d)	Each 100 CY (e)	Daily	Weekly	Monthly	Annually	Remarks
2.1.2	Fine aggregate gradation and deleterious substances		X								X		whichever occurs first
2.1.3	Coarse aggregate gradation and deleterious substances			X							X		whichever occurs first
2.1.4	Lightweight aggregate gradation and deleterious substances				X						X		whichever occurs first
5.2.2	Organic Impurities in fine aggregate											X	when aggregate is suspect
5.3.1	Slump, Slump Flow & VSI						X		X				whichever occurs first, for each mix design
5.3.2	Temperature of Concrete						X		X				when air content or slump is tested, for each mix design
5.3.3	Density (unit weight) of concrete						X			X			Except for lightweight concrete, for each mix design
5.3.3	Density (unit weight) of lightweight concrete							X			X		for each mix design
5.3.4	Air Content of air entrained concrete						X		X				whichever occurs first, for each mix design
5.3.5.3	Compressive strength of wet cast concrete						X			X			whichever occurs first, for each mix design
5.3.5.3	Compressive strength of dry cast concrete						X			X			whichever occurs first, for each mix design

Notes:

- (a) 1,350 metric tons
- (b) 1,800 metric tons
- (c) 150 cubic meters
- (d) 115 cubic meters
- (e) 75 cubic meters

CHAPTER 6 - SPECIAL REQUIREMENTS FOR SPECIFIC PRODUCTS

6.1 PRODUCTS MANUFACTURED ACCORDING TO ASTM INTERNATIONAL AND OTHER INDUSTRY STANDARDS

The requirements in this chapter are in addition and complementary to the requirements in chapters 1 through 5.

The requirements in sections 6.1 through 6.5 are intended for the producer to demonstrate that the final product is capable of performing in a manner consistent with ASTM International specifications and other industry standards that are used to verify acceptable product manufacture and performance.

6.1.1 Product Manufacture

Precast concrete products, which are covered by ASTM International or other industry standards, exclusive of those covered in Sections 6.2 through 6.5 of this manual, shall be manufactured in accordance with those standards, unless otherwise dictated by project specifications. In case of conflict between ASTM or other industry standards and product specifications, the product specifications, drawings, and other contract document requirements will govern. Additional product-specific requirements are outlined in Sections 6.2 through 6.5.

If the plant claims to manufacture certain products that meet ASTM specifications, then the plant should be able to prove such claims.

Whenever ASTM International or other industry standards are referenced in this manual, the latest edition of the standard shall apply, unless the specifier specifically requires conformance with an earlier edition.

Each individual ASTM International standard specifically states the necessary documentation and proof of conformance required.

Applicable precast concrete product-specific ASTM or other industry standards include are listed in Appendix A.

6.1.2 Proof of Conformance

Proof of conformance to specific ASTM International or other industry standards shall be maintained on file at the plant. Proof of conformance shall consist of one or more of the following: design calculations and drawings, documentation of performance testing, documentation of the design conditions and specific requirements stated in individual ASTM International or industry standards.

Proof of conformance with ASTM standards should be a normal part of the quality control operations, unless other more stringent design requirements are specified for projects.

STANDARD

COMMENTARY

6.1.3 Plant Requirements:

Proof of conformance to applicable ASTM International or other industry standards shall be documented and maintained on file at the plant for all products being produced according to ASTM International or other industry standards. Annual test data (or other test data) shall be maintained at the plant for a minimum of three years.

6.2 CONCRETE PIPE REQUIREMENTS

Plants producing concrete pipe shall specifically conform to the requirements in section 6.2 of this manual.

NOTE: Section 6.2 is intended for pipe that will be used for sanitary and stormwater drainage systems.

Additional testing may be required for pipe intended to be used for sanitary wastewater drainage systems.

6.2.1 STORMWATER CONCRETE PIPE REQUIREMENTS

6.2.1.1 Reinforcing Steel Inspection *

As required in Section 4.1.5 and 4.2.1, maintain documentation of reinforcing cage inspections with information on the required cage design versus the actual cage used, including WWR style, steel area, wire diameter, cage diameter, cage length, and welded/tied wire laps.

Concrete pipe reinforcing steel checks shall be performed on a minimum of one (1) reinforcing steel cages or 3% of each fabrication run daily, whichever is greater, chosen on a random basis by QC personnel, regardless of fabrication method. These checks shall be documented and maintained in the plant records for a minimum of three (3) years.

** Critical Requirement – plants participating in the NPCA Plant Certification Program must receive a minimum passing grade, as shown on the grading schedule, for section 6.2.1.1 and others designated as Critical Requirements, when applicable.*

6.2.1.2 Three-Edge Bearing Testing (TEB)*

For reinforced concrete pipe, verification of conformance to applicable standards (ASTM C76 and C655) shall be documented by performance of three-edge bearing testing in accordance with ASTM C497. The plant shall load the pipe up to the specified design strength D-load to produce a 0.01-inch crack. Test frequency shall be a minimum of one test per year for each size (and class) of pipe, or as described below, whichever is

** Critical Requirement – plants participating in the NPCA Plant Certification Program must receive a minimum passing grade, as shown on the grading*

STANDARD

COMMENTARY

greater. TEB tests are not required for sizes that have less than 100 pieces manufactured during the current program year if the plant has compressive and proof of design test data on file. Current test reports shall be dated not more than one year at the end of the month from the date of the last test or certification.

schedule, for section 6.2.1.2 and others designated as Critical Requirements, when applicable.

Three-edge bearing testing is critical since it is an industry-accepted method of verifying the strength and design of the pipe.

<u>Pipe Size</u>	<u>Class</u>	<u>Test Frequency*</u>
12" – 15"	Class V and below	1 / 1000 pieces
18" – 36"	Class IV and below	1 / 800 pieces
18" – 36"	Class V	1 / 400 pieces
42" – 60"	Class III and below	1 / 400 pieces
42" – 60"	Class IV and V	1 / 200 pieces
66" and larger	All Classes	As require by project specifications

For unreinforced concrete pipe, verification of conformance to applicable standards (ASTM C14 and C985) shall be demonstrated by performance of three-edge bearing testing in accordance with ASTM C497. The plant shall test up to the specified design strength ultimate load at the frequency required by the project specifications.

For pipe designed by direct methods with standard installations, three-edge bearing shall not be required.

If allowed by project specifications or authority having jurisdiction, compressive strength cylinder testing and companion rational design calculations may replace TEB testing.

Unless otherwise required by project specifications, three-edge bearing testing of elliptical and arch pipe shall not be required.

6.2.1.3 Absorption Testing *

Verification of conformance to the concrete absorption requirements of applicable standards shall be documented by performance of absorption testing in accordance with ASTM C497 (Test Method A or B). Absorption testing can be performed by ASTM C642 using cores only and the absorption limits of ASTM C76 shall apply. Testing shall be performed a minimum of once per year, on the mix design (both wet-cast and dry-cast) with the lowest amount of cementitious material used at each operation or manufacturing station. Both in-plant and laboratory testing shall be

** Critical Requirement – plants participating in the NPCA Plant Certification Program must receive a minimum passing grade, as shown on the grading schedule, for section 6.2.1.3 and others designated as*

STANDARD

COMMENTARY

permitted. Current test reports shall be dated not more than one year at the end of the month from the date of the last test or certification.

Critical Requirements, when applicable.

6.2.1.4 Dimensional Checks

Verification of conformance to applicable dimensional requirements shall be performed and documented on a minimum of three concrete pipes or 3% of each day's production, whichever is greater, chosen randomly by plant quality control personnel.

Normal Post-pour inspection requirements apply to both wet-cast and dry-cast / machine-cast pipe, as required in Sections 4.6.4 and 4.6.5.

Procedures for checking pipe dimensions and the associated acceptable tolerances should be documented in the plant-specific QC manual, as outlined in Section 1.1.2 of this manual.

At a minimum, dimensional checks shall include internal diameter, wall thickness, and length of two opposite sides (measured directly across from each other). Joints must be checked for dimensional conformance with either manufacturer's specifications, applicable standards and/or specifying authorities. If project specifications or the authority having jurisdiction requirements are more stringent then they shall apply.

6.2.1.5 Joint Design and Testing

Joints shall be designed according to the applicable requirements in ASTM C443, ASTM C990, or as required by project specifications. Critical dimensions and allowable tolerances shall be clearly indicated on the resulting joint design drawings. Joint designs drawings must be kept on file and readily available for routine and audit inspection personnel.

Proper joint designs are crucial to the performance of installed pipe when infiltration or exfiltration are a factor in the project. Joint proof-of-design testing is required only in cases where the plant uses gasketed joints.

The plant shall perform and document joint proof-of-design leakage testing on each size of gasketed pipe produced at the plant. Testing shall be repeated whenever joint or gasket designs are modified. Joint proof-of-design testing, unless otherwise required by the authority or authorities having jurisdiction, shall consist of either vacuum or hydrostatic testing conducted in two configurations:

- 1) Assembled in-line (rectilinearly) and
- 2) Assembled with one side of the joint open 1/2-in. more than the opposite side.

6.2.1.6 Watertightness Hydrostatic Testing

Testing shall be performed according to the hydrostatic test method set forth in ASTM C497. Any water leaking from the joint being tested must be collected for measurement at the end of the test. Pipe shall be tested up to 3.0 psi for 10 minutes and the leakage shall not exceed:

Pipe temperature should be as close to ambient as possible at the time of testing in order to ensure

STANDARD

COMMENTARY

0.041 oz / (inch internal pipe dia.)(ft. of pipe length)

accuracy and consistency of test results.

Pipe that does not pass this test may be repaired and retested.

This test shall be performed initially or whenever equipment or processes change.

6.2.1.7 Watertightness Vacuum Testing

Testing shall be performed with a negative test pressure (vacuum) equivalent to 7 inches of mercury. The pipe being tested shall maintain a minimum of 6.9 inches of mercury throughout the test time period (T_{test}), which is calculated as follows:

$$T_{\text{test}} \text{ (seconds)} = 1.5 \times \text{internal diam. of the pipe (inches)}$$

If the pipe being tested does not hold the required vacuum, it may be repaired and retested.

This test shall be performed initially or whenever equipment or processes change.

6.2.1.8 Gasket Quality Control

The plant shall ensure that the rubber joint gaskets supplied with precast and pipe products are suitable for the application. This suitability shall be determined through the following:

1. Annual certification of physical properties of the rubber compound as required by the specification under which the gaskets are supplied; and
2. Measurement or certification of critical gaskets physical characteristics including (at a minimum):
 - Cross-section height and width (profile and prelubricated gaskets only)
 - Volume (ASTM C497) and diameter (o-ring gaskets only)
 - Durometer (ASTM D2240)
 - Cut length (ASTM C497)
 - Splice strength

Measurement or certification shall be accomplished by any of the following methods:

- a. The gasket supplier shall furnish documentation of the required characteristics by sampling at least 1 gasket each quarter of each

Gasket quality control documentation is required only in cases where the plant actually uses gasketed joints.

These requirements do not apply to joint sealants or pipe-to-structure connectors, which are covered in section 2.3.6.

Certificates of Conformance should clearly state that the gaskets meet the applicable ASTM specification. Concrete pipe joint gaskets typically must conform to ASTM C443.

STANDARD

- size and type supplied and provide the aforementioned measurements for those gaskets; or
- b. The gasket supplier shall furnish evidence of current registration of its quality system to a recognized third-party audited standard (e.g. – ISO 9001-2000) and certify that the aforementioned measurements are recorded and maintained within this system once per year; or
 - c. Using specifications and tolerances as supplied by the gasket manufacturer and the precast manufacturer, the precast manufacturer or a competent third party technical service shall perform the aforementioned measurements above by sampling at least 1 of each 300 gaskets of each size and type received and maintain records of the measurements made. (If project specifications or the authority having jurisdiction require a frequency of testing greater than 1/300 then they shall apply.)

If any of the measurements required above indicate that the gasket is not within acceptable tolerances, additional testing shall be performed to determine if the remainder of the lot should be used. Gaskets which are not within acceptable tolerances shall be segregated from usable stock and clearly marked so as to preclude their use or transfer.

Current certification reports shall be dated not more than one year at the end of the month from the date of the last test or certification.

6.2.1.9 Plant Requirements:

1. As required in Section 4.1.5, 4.2.1 and 6.2.1, maintain documentation of reinforcing cage inspections with information on the required cage design versus the actual cage used.
2. Three-edge bearing testing techniques of concrete pipe, per ASTM C497 when required by the applicable ASTM standard, shall be witnessed by the agency inspector during an NPCA Plant Certification inspection. The plant inspector shall witness all three-edge bearing tests.
3. Test records and dimensional check documentation shall be maintained at the plant for a minimum of three (3) years.
4. Detailed reinforcing cage design drawings shall be readily available in the steel fabrication/production area.
5. Gasket certification records and/or quality control records shall be maintained at the plant for a minimum of three (3) years.

COMMENTARY

For height, width and diameter measurements, several measurements should be made along the length of the gasket, away from the splice, and the average value should be recorded.

For splice strength testing, the gasket should be stretched approximately 100% and the splice visually inspected for defects and/or separation.

STANDARD

COMMENTARY

- 6. Joint design and proof-of-design testing documentation shall be maintained on file at the plant indefinitely.
- 7. As required in Section 4.1.3, maintain documentation of pallet, header and truing rings as long as each respective piece of forming equipment is in use at the plant.

6.2.2 SANITARY CONCRETE PIPE REQUIREMENTS

6.2.2.1 Reinforcing Steel Inspection *

As required in Section 4.1.5 and 4.2.1, maintain documentation of reinforcing cage inspections with information on the required cage design versus the actual cage used, including WWR style, steel area, wire diameter, cage diameter, cage length, and welded/tied wire laps.

Concrete pipe reinforcing steel checks shall be performed on a minimum of one (1) reinforcing steel cages or 3% of each fabrication run daily, whichever is greater, chosen on a random basis by QC personnel, regardless of fabrication method. These checks shall be documented and maintained in the plant records for a minimum of three (3) years.

6.2.2.2 Three-Edge Bearing Testing (TEB) *

For reinforced concrete pipe, verification of conformance to applicable standards (ASTM C76 and C655) shall be documented by performance of three-edge bearing testing in accordance with ASTM C497. The plant shall load the pipe up to the specified design strength D-load to produce a 0.01-inch crack. Test frequency shall be a minimum of one test per year for each size (and class) of pipe, or as described below, whichever is greater. TEB tests are not required for sizes that have less than 100 pieces manufactured during the current program year if the plant has compressive and proof of design test data on file. Current test reports shall be dated not more than one year at the end of the month from the date of the last test or certification.

** Critical Requirement – plants participating in the NPCA Plant Certification Program must receive a minimum passing grade, as shown on the grading schedule, for section 6.2.2.1 and others designated as Critical Requirements, when applicable.*

** Critical Requirement – plants participating in the NPCA Plant Certification Program must receive a minimum passing grade, as shown on the grading schedule, for section 6.2.2.2 and others designated as Critical Requirements, when applicable.*

Three-edge bearing testing is critical since it is an industry-accepted method of verifying the strength and design of the pipe.

<u>Pipe Size</u>	<u>Class</u>	<u>Test Frequency*</u>
12" – 15"	Class V and below	1 / 1000 pieces
18" – 36"	Class IV and below	1 / 800 pieces
18" – 36"	Class V	1 / 400 pieces
42" – 60"	Class III and below	1 / 400 pieces
42" – 60"	Class IV and V	1 / 200 pieces
66" and larger	All Classes	As require by project specifications

STANDARD

COMMENTARY

For unreinforced concrete pipe, verification of conformance to applicable standards (ASTM C14 and C985) shall be demonstrated by performance of three-edge bearing testing in accordance with ASTM C497. The plant shall test up to the specified design strength ultimate load at the frequency required by the project specifications.

For pipe designed by direct methods with standard installations, three-edge bearing shall not be required.

If allowed by project specifications or authority having jurisdiction, compressive strength cylinder testing and companion rational design calculations may replace TEB testing.

Unless otherwise required by project specifications, three-edge bearing testing of elliptical and arch pipe shall not be required.

6.2.2.3 Absorption Testing *

Verification of conformance to the concrete absorption requirements of applicable standards shall be documented by performance of absorption testing in accordance with ASTM C497 (Test Method A or B). Absorption testing can be performed by ASTM C642 using cores only and the absorption limits of ASTM C76 shall apply. Testing shall be performed a minimum of once per year, on the mix design (both wet-cast and dry-cast) with the lowest amount of cementitious material used at each operation or manufacturing station. Both in-plant and laboratory testing shall be permitted. Current test reports shall be dated not more than one year at the end of the month from the date of the last test or certification.

6.2.2.4 Dimensional Checks

Verification of conformance to applicable dimensional requirements shall be performed and documented on a minimum of three concrete pipes or 3% of each day's production, whichever is greater, chosen randomly by plant quality control personnel.

Normal Post-pour inspection requirements apply to both wet-cast and dry-cast / machine-cast pipe, as required in Sections 4.6.4 and 4.6.5.

At a minimum, dimensional checks shall include internal diameter, wall thickness, and length of two opposite sides (measured directly across from each other). Joints must be checked for dimensional conformance with either manufacturer's specifications, applicable standards and/or specifying authorities. If project specifications or the authority having jurisdiction requirements are more stringent then they shall apply.

** Critical Requirement – plants participating in the NPCA Plant Certification Program must receive a minimum passing grade, as shown on the grading schedule, for section 6.2.2.3 and others designated as Critical Requirements, when applicable.*

Procedures for checking pipe dimensions and the associated acceptable tolerances should be documented in the plant-specific QC manual, as outlined in Section 1.1.2 of this manual.

6.2.2.5 Joint Design and Testing

Joints shall be designed according to the applicable requirements in ASTM C361, C1628, or as required by the project specifications. Critical dimensions and allowable tolerances shall be clearly indicated on the resulting joint design drawings. Joint design drawings must be kept on file and readily available for routine and audit inspection personnel.

If required by the project specifications or authority having jurisdiction, joint design and testing shall be performed in accordance with ASTM C361.

If required by the project specifications or authority having jurisdiction, joint design and testing shall be performed in accordance with ASTM C 1628.

The plant shall perform and document joint proof-of-design leakage testing on each size of gasketed pipe produced at the plant. Testing shall be repeated whenever joint or gasket designs are modified. Joint proof-of-design testing, unless otherwise required by the authority or authorities having jurisdiction, shall consist of either vacuum or hydrostatic testing conducted in two configurations:

- 1) Assembled in-line (rectilinearly) and
- 2) Assembled with one side of the joint open 1/2-in. more than the opposite side.

6.2.2.6 Watertightness Hydrostatic Testing

If required by the project specifications or authority having jurisdiction, testing shall be performed according to the hydrostatic test method set forth in ASTM C361. Pipe shall be tested up to 13.0 psi for 2 – ½ minutes with no leakage.

If required by the project specifications or authority having jurisdiction, testing shall be performed according to the hydrostatic test method set forth in ASTM C1628. Pipe shall be tested up to 13.0 psi for 2 – ½ minutes with no leakage.

6.2.2.7 Watertightness Requirements

If required by project specifications or the authority having jurisdiction, plants shall perform watertightness testing per the following:

Size	Frequency	Method	Test Criteria
12-36"	100%	Vacuum	ASTM C1618
12-36"	100%	Hydrostatic	ASTM C497
42" >	1 per 100	Vacuum	ASTM C1618
42" >	1 per 100	Hydrostatic	ASTM C497

6.2.2.8 Off-Center Joint Proof of Design Testing

If required by project specifications or the authority having jurisdiction, plants shall perform and maintain records of Off-Center Joint Proof of Design testing per ASTM C497 on each applicable size of gasketed pipe. Testing shall be repeated whenever joint or gasket designs are modified.

6.2.2.9 Joint Shear Proof of Design Testing

If required by project specifications or the authority having jurisdiction, plants shall perform and maintain records of Joint Shear Proof of Design testing per ASTM C497 on each applicable pipe size of gasketed pipe. Testing shall be repeated whenever joint or gasket designs are modified.

6.2.2.10 Confined Gasket Proof of Design Testing

If required by project specifications or the authority having jurisdiction, plants shall perform and maintain records of Confined Gasket Proof of Design Testing per ASTM C361. Testing shall be repeated whenever joint or gasket designs are modified.

If required by project specifications or the authority having jurisdiction, plants shall perform and maintain records of Confined Gasket Proof of Design Testing per ASTM C1628. Testing shall be repeated whenever joint or gasket designs are modified.

STANDARD

COMMENTARY

6.2.2.11 Gasket Quality Control

The plant shall ensure that the rubber joint gaskets supplied with precast and pipe products are suitable for the application. This suitability shall be determined through the following:

1. Annual certification of physical properties of the rubber compound as required by the specification under which the gaskets are supplied; and
2. Measurement or certification of critical gaskets physical characteristics including (at a minimum):
 - Cross-section height and width (profile and prelubricated gaskets only)
 - Volume (ASTM C497) and diameter (o-ring gaskets only)
 - Durometer (ASTM D2240)
 - Cut length (ASTM C497)
 - Splice strength

Measurement or certification shall be accomplished by any of the following methods:

- a. The gasket supplier shall furnish documentation of the required characteristics by sampling at least 1 gasket each quarter of each size and type supplied and provide the aforementioned measurements for those gaskets; or
- b. The gasket supplier shall furnish evidence of current registration of its quality system to a recognized third-party audited standard (e.g. – ISO 9001-2000) and certify that the aforementioned measurements are recorded and maintained within this system once per year; or
- c. Using specifications and tolerances as supplied by the gasket manufacturer and the precast manufacturer, the precast manufacturer or a competent third party technical service shall perform the aforementioned measurements above by sampling at least 1 of each 300 gaskets of each size and type received and maintain records of the measurements made. (If project specifications or the authority having jurisdiction require a frequency of testing greater than 1/300 then they shall apply.)

If any of the measurements required above indicate that the gasket is not within acceptable tolerances, additional testing shall be performed to determine if the remainder of the lot should be used. Gaskets which are not within acceptable tolerances shall be segregated from usable stock and clearly marked so as to preclude their use or transfer.

Current certification reports shall be dated not more than one year at the end of the month from the date of the last test or certification.

Gasket quality control documentation is required only in cases where the plant actually uses gasketed joints.

These requirements do not apply to joint sealants or pipe-to-structure connectors, which are covered in section 2.3.6.

Certificates of Conformance should clearly state that the gaskets meet the applicable ASTM specification. Concrete pipe joint gaskets typically must conform to ASTM C443.

For height, width and diameter measurements, several measurements should be made along the length of the gasket, away from the splice, and the average value should be recorded.

For splice strength testing, the gasket should be stretched approximately 100% and the splice visually inspected for defects and/or separation.

STANDARD

COMMENTARY

6.2.2.12 Plant Requirements:

1. As required in Section 4.1.5, 4.2.1 and 6.2.1, maintain documentation of reinforcing cage inspections with information on the required cage design versus the actual cage used.
2. Three-edge bearing testing techniques of concrete pipe, per ASTM C497 when required by the applicable ASTM standard, shall be witnessed by the agency inspector during an NPCA Plant Certification inspection. The plant inspector shall witness all three-edge bearing tests.
3. Test records and dimensional check documentation shall be maintained at the plant for a minimum of three (3) years.
4. Detailed reinforcing cage design drawings shall be readily available in the steel fabrication/production area.
5. Gasket certification records and/or quality control records shall be maintained at the plant for a minimum of three (3) years.
6. Joint design and proof-of-design testing documentation shall be maintained on file at the plant indefinitely.
7. As required in Section 4.1.3, maintain documentation of pallet, header and truing rings as long as each respective piece of forming equipment is in use at the plant.

6.3 ROUND MANHOLE REQUIREMENTS

Plants producing round manholes and associated components according to ASTM C478 "Standard Specification for Precast Reinforced Concrete Manhole Sections" shall specifically conform to the requirements in section 6.3 of this manual.

Section 6.3 pertains to manhole structures that are intended for utility, storm water drainage or sanitary wastewater drainage structures.

6.3.1 Reinforcing Steel Inspection *

As required in Section 4.1.5 and 4.2.1, maintain documentation of reinforcing cage inspections with information on the required cage design versus the actual cage used, including WWR style, steel area, wire diameter, cage diameter, cage length, and welded/tied wire laps.

** Critical Requirement – plants participating in the NPCA Plant Certification Program must receive a minimum passing grade, as shown on the grading schedule, for section 6.3.1*

STANDARD

COMMENTARY

Reinforcing steel inspection is not required if reinforcing steel is not used in certain manhole products or when fiber reinforcement is used in lieu of conventional reinforcing steel.

and others designated as Critical Requirements, when applicable.

Manhole reinforcing steel checks shall be performed on a minimum of one (1) reinforcing steel cage or 3% of each fabrication run daily, whichever is greater, chosen on a random basis by QC personnel, regardless of fabrication method. These checks shall be documented and maintained in the plant records for a minimum of three (3) years.

6.3.2 Flat Slab Tops

Verify the design for each size flat slab top produced or stocked by the plant, either by maintaining rational design calculations or by proof testing, as outlined in the applicable section(s) of ASTM C497. The design shall meet the minimum requirements of ASTM C478.

Note: The minimum reinforcing steel requirements for flat slab tops outlined in ASTM C478 represent the absolute minimum steel that should be used in flat tops. Additional reinforcement and/or slab thickness may be required to adequately support the design loads.

Design calculations shall be performed and stamped by a qualified, licensed engineer. Proof testing (when performed) shall also be reviewed and signed-off by a qualified, licensed engineer.

6.3.3 Base, Riser and Cone Sections

6.3.3.1 Absorption Testing *

Verification of conformance to the concrete absorption requirements of ASTM C478 shall be documented by performance of absorption testing in accordance with ASTM C497 (Test Method A or B). Absorption testing can be performed by ASTM C642 using cores only and the absorption limits of ASTM C478 shall apply. Testing shall be performed a minimum of once per year, on the mix design (both wet-cast and dry-cast) with the lowest amount of cementitious material used at each operation or manufacturing station. Both in-plant and laboratory testing shall be permitted. Current test reports shall be dated not more than one year at the end of the month from the date of the last test or certification.

** Critical Requirement – plants participating in the NPCA Plant Certification Program must receive a minimum passing grade, as shown on the grading schedule, for section 6.3.3.1 and others designated as Critical Requirements, when applicable.*

In order to obtain a true representative test for dry-cast products, it is suggested that a test from

STANDARD

COMMENTARY

each manufacturing operation or station be conducted.

6.3.3.2 Step Testing

Step vertical and horizontal load testing must be performed according to the applicable section(s) of ASTM C497 once per year, per step design used and whenever a new step supplier is used. The step testing must be performed in the precast plant in the product for its intended use. The testing must be performed or witnessed and results documented by a member of the precasters Quality Control Department. The loads achieved must meet the requirements of ASTM C478. Current test reports shall be dated not more than one year at the end of the month from the date of the last test or certification.

Spot checks of proper installation of steps should be included in post-pour inspections.

6.3.3.3 Dimensional Checks

Verification of conformance to ASTM C478 dimensional requirements shall be performed and documented (regardless of production method) on a minimum of three manhole sections or 3% of each day's production, whichever is greater, chosen randomly by plant quality control personnel.

Normal post-pour inspection requirements apply to both wet-cast and dry-cast / machine-cast manholes, as required in Sections 4.6.4 and 4.6.5.

At a minimum, dimensional checks shall include: manhole internal diameter; wall thickness; height of two opposite sides; verification of hole locations and size (when applicable); and verification of the invert dimensions and elevations (when applicable).

Procedures for checking manhole dimensions and the associated acceptable tolerances should be documented in the plant-specific QC manual, as outlined in section 1.1.2 of this manual.

STANDARD

COMMENTARY

6.3.3.4 Sanitary Manhole Vacuum Testing

If in-plant vacuum testing of sanitary manhole sections is required by the authority having jurisdiction, the plant shall maintain documentation of such testing on file at the plant for a minimum of three (3) years.

Vacuum testing after installation and prior to backfilling operations is the preferred method of watertightness testing of sanitary manholes. Testing should be performed according to ASTM C1244.

6.3.4 Joint Design

Joints shall be designed to perform as required in ASTM C443, ASTM C990, or as required by project requirements. Critical dimensions and allowable tolerances shall be clearly indicated on the joint design drawings.

Proper joint designs are crucial to the performance of installed manhole structures when infiltration or exfiltration are a factor in the project.

6.3.5 Gasket Quality Control

The plant shall ensure that the rubber joint gaskets supplied with precast and pipe products are suitable for the application. This suitability shall be determined through the following:

Gasket quality control documentation is required only in cases where the plant actually uses gasketed joints.

1. Annual certification of physical properties of the rubber compound as required by the specification under which the gaskets are supplied; and
2. Measurement or certification of critical gaskets physical characteristics including (at a minimum):
 - Cross-section height and width (profile and prelubricated gaskets only)
 - Volume (ASTM C497) and diameter (o-ring gaskets only)
 - Durometer (ASTM D2240)
 - Cut length (ASTM C497)
 - Splice strength

These requirements do not apply to joint sealants or pipe-to-structure connectors, which are covered in section 2.3.6.

Measurement or certification shall be accomplished by any of the following methods:

Certificates of Conformance should clearly state that the gaskets meet the applicable ASTM specification. Manhole joint gaskets typically must conform to ASTM C443.

- a. The gasket supplier shall furnish documentation of the required characteristics by sampling at least 1 gasket each quarter of each size and type supplied and provide the aforementioned measurements for those gaskets; or
- b. The gasket supplier shall furnish evidence of current registration of its quality system to a recognized third-party audited standard (e.g. – ISO 9001-2000)

For height, width and diameter measurements, several measurements should be made along the length of the gasket, away from the splice, and the

STANDARD

- and certify that the aforementioned measurements are recorded and maintained within this system once per year; or
- c. Using specifications and tolerances as supplied by the gasket manufacturer and the precast manufacturer, the precast manufacturer or a competent third party technical service shall perform the aforementioned measurements by sampling at least 1 of each 300 gaskets of each size and type received and maintain records of the measurements made.

If any of the measurements required above indicate that the gasket is not within acceptable tolerances, additional testing shall be performed to determine if the remainder of the lot should be used. Gaskets which are not within acceptable tolerances shall be segregated from usable stock and clearly marked so as to preclude their use or transfer.

Current certification reports shall be dated not more than one year at the end of the month from the date of the last test or certification.

6.3.6 Plant Requirements:

1. As required in Section 4.1.5, 4.2.1 and 6.3.1, maintain documentation of reinforcing cage inspections with information on the required cage design versus the actual cage used. Reinforcing steel inspection documentation shall be maintained on file at the plant for a minimum of three (3) years.
2. Documentation of rational design calculations and/or proof-of-design testing of flat slab tops shall be maintained at the plant indefinitely.
3. Documentation of riser and cone section dimensional checks and/or performance testing shall be maintained at the plant for a minimum of three (3) years.
4. Joint design documentation shall be maintained at the plant indefinitely.
5. Gasket certification records and/or quality control records shall be maintained at the plat for a minimum of three (3) years.
6. Detailed reinforcing cage design drawings shall be readily available in the steel fabrication/production area.
7. As required in Section 4.1.3, maintain documentation of pallet, header and truing rings as long as each respective piece of forming equipment is in use at the plant.

COMMENTARY

average value should be recorded.

For splice strength testing, the gasket should be stretched approximately 100% and the splice visually inspected for defects and/or separation.

6.4 BOX CULVERT REQUIREMENTS

Plants producing box culverts shall document proof of conformance with ASTM C1433 'Specification for Precast Reinforced Concrete Monolithic Box Sections for Culverts, Storm Drains, and Sewers', ASTM C1577 'Specification for Precast Reinforced Concrete Monolithic Box Sections for Culverts, Storm Drains, and Sewers Designed According to AASHTO LRFD', or ASTM C1786 'Specification for Segmental Precast Reinforced Concrete Box Sections for Culverts, Storm Drains, and Sewers Designed According to AASHTO LRFD' and / or other manufacturing requirements mandated by the authority having jurisdiction. Plants producing box culverts shall specifically conform to the requirements of Section 6.4 of this manual.

6.4.1 Absorption Testing

Absorption testing shall be performed and documented in accordance with ASTM C497 (Test Method A or B). Absorption testing can be performed by ASTM C642 using cores only and the absorption limits of ASTM C76 or C478 shall apply. Testing shall be performed a minimum of once per year, on the mix design with the lowest amount of cementitious material at each operation or manufacturing station. Both in-plant and laboratory testing shall be permitted. Current test reports shall be dated not more than one year at the end of the month from the date of the last test or certification.

6.4.2 Joint Design

Joints design drawings shall be maintained on file at the plant for each joint design used. Critical dimensions and allowable tolerances shall be clearly indicated on the joint design drawings. As a proof of design, the plant shall maintain documentation on file indefinitely showing that when assembled; the joint gap between any two box culvert sections is not greater than 3/4 inch (19 mm) in any one location.

Proper joint designs are crucial to the performance of installed box culvert structures when infiltration or exfiltration are a factor in the project. In addition, the joint must be capable of transferring loads across the joint from one section to another.

STANDARD

COMMENTARY

6.4.3 Pre-Pour Inspections *

In addition to standard pre-pour inspections required in Section 4.3 of this manual, the plant shall also specifically check critical form dimensions including top, bottom and wall thicknesses. The plant shall verify and document compliance with the design drawings by performing a detailed reinforcement check. As required in Section 4.1.5 and 4.2.1, maintain documentation of reinforcing cage inspections for each box culvert reinforcing steel cage with information on the required cage design versus the actual cage used, steel areas, WWR style, cage length, and welded/tied wire laps.

** Critical Requirement – plants participating in the NPCA Plant Certification Program must receive a minimum passing grade, as shown on the grading schedule, for section 6.4.3 and others designated as Critical Requirements, when applicable.*

A sample box culvert inspection form can be found in Appendix B of this manual.

6.4.4 Dimensional Checks *

In addition to standard post-pour inspections required in Section 4.6.4 of this manual, the plant shall also specifically check critical product dimensions including top slab, bottom slab and wall thicknesses, and inside length, width and height. These dimensional checks shall be performed on at least one box culvert produced in each form per day.

** Critical Requirement – plants participating in the NPCA Plant Certification Program must receive a minimum passing grade, as shown on the grading schedule, for section 6.4.4 and others designated as Critical Requirements, when applicable.*

Procedures for checking box culvert dimensions and the associated acceptable tolerances should be documented in the plant-specific QC manual, as outlined in section 1.1.2 of this manual.

6.4.5 Plant Requirements:

1. Pre-pour inspection and dimensional check documentation shall be maintained at the plant for a minimum of three years.

STANDARD

COMMENTARY

2. Joint design documentation shall be maintained on file at the plant indefinitely. During an NPCA Plant Certification inspection, the inspector may require the plant to demonstrate that when assembled, the joint gap between any two box culvert sections is not greater than 3/4 inch (19 mm) in any one location. The inspector may choose box culverts sections at his/her discretion from reasonably-sized stock in the plant.
3. Detailed reinforcing cage design drawings shall be readily available in the steel fabrication/production area.

6.5 SEPTIC TANK REQUIREMENTS

Plants producing septic tanks shall document proof of conformance with ASTM C1227 "Standard Specification for Precast Concrete Septic Tanks", IAPMO/ANSI Z1000 'Prefabricated Septic Tanks' or other manufacturing requirements mandated by the authority having jurisdiction. The plant shall specifically conform to the requirements in section 6.5 of this manual.

It is suggested that plants producing septic tanks follow the practices outlined in the "NPCA Precast Concrete On-site Wastewater Tanks Best Practices Manual."

6.5.1 Structural Proof-of-Design

Structural proof-of-design shall be demonstrated either by calculation or by proof testing.

Proof-of-design should be demonstrated for the maximum design burial depth, accounting for the local surface, soil and hydrostatic loading conditions.

Design calculations shall be performed and stamped by a qualified, licensed engineer. Proof testing in lieu of design calculations shall be reviewed and signed-off by a qualified, licensed engineer.

6.5.2 Watertightness Testing *

Tank watertightness shall be demonstrated according to the applicable section(s) of ASTM C1227, ASTM C1719, IAPMO/ANSI Z1000, or the requirements set forth by the authority having jurisdiction, whichever is more stringent. A minimum of one test per year on a septic tank produced in each septic tank form used at the plant shall be performed and documented. If the authority having jurisdiction require a greater frequency of testing, the plant shall maintain records of all additional tests at the plant.

** Critical Requirement – plants participating in the NPCA Plant Certification Program must receive a minimum passing grade, as shown on the grading schedule, for section 6.5.2 and others designated as Critical Requirements, when applicable.*

Watertightness testing may be performed and documented at the plant and shall be witnessed and signed off by the plant QC Manager.

STANDARD

COMMENTARY

Watertightness testing may be conducted in the field prior to backfill and shall be witnessed and signed off by the authority having jurisdiction.

Watertightness testing of a tank produced in each form is necessary to ensure that all forming equipment remains within appropriate tolerances.

In cases when multiple tank sizes are manufactured using the same form, watertightness testing shall be performed on the largest (tallest) structure, as long as the same concrete mix design is used.

Forms, whose castings have been tested and meet the requirements, may be used to produce septic tanks or grease interceptors without additional testing.

For individual tanks models manufactured using panel type forms, a single tank of each model shall be tested per year.

As an example: plants manufacturing 1,000, 1,500, and 2,000 gallon tank models with panel forms, only a single tank model per year would require watertightness testing.

In cases where tanks are physically too large to assemble, water test and disassemble at the plant without damage, or in areas where the Authority Having Jurisdiction has no requirements for watertightness testing; watertightness testing requirement is waived.

Current test reports shall be dated not more than one year at the end of the month from the date of the last test or certification.

6.5.3 Plant Requirements:

1. Documentation of rational design calculations and/or proof-of-design testing of septic tanks shall be maintained at the plant indefinitely.
2. Watertightness test records shall be maintained on file at the plant for a minimum of three years.
3. For plants participating in the NPCA Product Listing Program, a watertightness test shall be witnessed by the agency inspector during an NPCA Plant Certification inspection. The tank to be tested shall be chosen at random from plant inventory by the agency inspector.

It is suggested that plants producing septic tanks follow the practices outlined in the "NPCA Precast Concrete On-site Wastewater Tanks Best Practices Manual."

6.6 GREASE INTERCEPTOR REQUIREMENTS

Plants producing grease interceptor tanks shall document proof of conformance with ASTM C1613 “Standard Specification for Precast Concrete Grease Interceptor Tanks”, IAPMO/ANSI Z1001 ‘Prefabricated Gravity Grease Interceptors’, or other manufacturing requirements mandated by the authority having jurisdiction. The plant shall specifically conform to the requirements in section 6.6 of this manual.

Proof-of-design should be demonstrated for the maximum design burial depth, accounting for the local surface, soil and hydrostatic loading conditions.

6.6.1 Structural Proof-of-Design

Structural proof-of-design shall be demonstrated either by calculation or by proof testing.

Design calculations shall be performed and stamped by a qualified, licensed engineer. Proof testing in lieu of design calculations shall be reviewed and signed-off by a qualified, licensed engineer.

6.6.2 Watertightness Testing *

Tank watertightness shall be demonstrated according to the applicable section(s) of ASTM C1613, ASTM C1719, IAPMO/ANSI Z1001 or the requirements set forth by the authority having jurisdiction, whichever is more stringent. A minimum of one test per year on a grease interceptor tank produced in each grease interceptor tank form used at the plant shall be performed and documented. If the authority having jurisdiction require a greater frequency of testing, the plant shall maintain records of all additional tests at the plant.

** Critical Requirement – plants participating in the NPCA Plant Certification Program must receive a minimum passing grade, as shown on the grading schedule, for section 6.6.2 and others designated as Critical Requirements, when applicable.*

Watertightness testing may be performed and documented at the plant and shall be witnessed and signed off by the plant QC Manager.

Watertightness testing of any tank produced in each form is necessary to ensure that all forming equipment remains within appropriate tolerances.

Watertightness testing may be conducted in the field prior to backfill and shall be witnessed and signed off by the authority having jurisdiction.

In cases when multiple tank sizes are manufactured using the same form, watertightness testing shall be performed on the largest (tallest) structure, as long as the same concrete mix design is used. Otherwise, testing shall be performed on each individual tank design.

Forms, whose castings have been tested and meet the requirements, may be used to produce grease interceptors or

STANDARD

For individual tanks models manufactured using panel type forms, a single tank of each model shall be tested per year.

In cases where tanks are physically too large to assemble, water test and disassemble at the plant without damage, or in areas where the Authority Having Jurisdiction has no requirements for watertightness testing; watertightness testing requirement is waived.

Current test reports shall be dated not more than one year at the end of the month from the date of the last test or certification.

6.6.3 Plant Requirements:

1. Documentation of rational design calculations and/or proof-of-design testing of septic tanks shall be maintained at the plant indefinitely.
2. Watertightness test records shall be maintained on file at the plant for a minimum of three years.
3. For plants participating in the NPCA Product Listing Program, a watertightness test shall be witnessed by the agency inspector during an NPCA Plant Certification inspection. The tank to be tested shall be chosen at random from plant inventory by the agency inspector.

COMMENTARY

septic tanks without additional testing. As an example: plants manufacturing 1,000, 1,500, and 2,000 gallon tank models with panel forms, only a single tank model per year would require watertightness testing.

APPENDIX A

STANDARDS CITED IN THE MANUAL AND REFERENCES

AASHTO STANDARDS

American Association of State Highway and Transportation Officials can be obtained from:

American Association of State
Highway and Transportation Officials
444 North Capitol Street, NW
Suite 249
Washington, DC 20001
Web: www.transportation.org

Plants required by federal, state and/or local requirements may substitute the most recent version of the equivalent AASHTO standard to replace ASTM requirements in this manual.

ACI STANDARDS

American Concrete Institute standards and other publications can be obtained from:

American Concrete Institute
PO Box 9094
Farmington Hills MI 48333-9094
Phone: 248-848-3700
Web: www.concrete.org

ACI Standards cited in this manual:

ACI 211.1 "Practice for Selecting Proportions for Normal, Heavyweight, and Mass Concrete"

ACI 211.2 "Practice for Selecting Proportions for Structural Lightweight Concrete"

ACI 211.3 "Practice for Selecting Proportions for No-Slump Concrete"

ACI 237 "Self-Consolidating Concrete"

ACI 302 "Guide for Concrete Floor and Slab Construction"

ACI 304 "Guide for Measuring, Mixing, Transporting, and Placing Concrete"

ACI 305R "Hot Weather Concreting"

ACI 306R "Cold Weather Concreting"

- ACI 318 "Building Code Requirements for Structural Concrete"
- ACI 350 "Code Requirements for Environmental Engineering Concrete Structures"

ASTM INTERNATIONAL STANDARDS

ASTM International standards and other publications can be obtained from:

ASTM International
100 Barr Harbor Drive
West Conshohocken PA 19428-2959
Phone: 610-832-9500
Web: www.astm.org

ASTM Standards cited in this manual (SI equivalents may also be applicable):

- ASTM A36 "Standard Specification for Carbon Structural Steel"
- ASTM A108 "Standard Specification for Steel Bars, Carbon, Cold-Finished, Standard Quality"
- ASTM A184 "Standard Specification for Welded Deformed Steel Bar Mats for Concrete Reinforcement"
- ASTM A615 "Standard Specification for Deformed and Plain Billet-Steel Bars for Concrete Reinforcement"
- ASTM A706 "Standard Specification for Low-Alloy Steel Deformed and Plain Bars for Concrete Reinforcement"
- ASTM A767 "Standard Specification for Zinc-Coated (Galvanized) Steel Bars for Concrete Reinforcement"
- ASTM A775 "Standard Specification for Epoxy-Coated Steel Reinforcing Bars"
- ASTM A820 "Standard Specification for Steel Fibers for Fiber-Reinforced Concrete"
- ASTM A884 "Standard Specification for Epoxy-Coated Steel Wire and Welded Wire Fabric for Reinforcement"
- ASTM A934 "Standard Specification for Epoxy-Coated Prefabricated Steel Reinforcing Bars"
- ASTM A1064 "Standard Specification for Steel Wire and Welded Wire Reinforcement, Plain and Deformed for Concrete"

ASTM C14	“Standard Specification for Nonreinforced Concrete Sewer, Storm Drain, and Culvert Pipe”
ASTM C31	“Standard Practice for Making and Curing Concrete Test Specimens in the Field”
ASTM C33	“Standard Specification for Concrete Aggregates”
ASTM C39	“Standard Test Method for Compressive Strength of Cylindrical Concrete Specimens”
ASTM C40	“Standard Test Method for Organic Impurities in Fine Aggregates for Concrete”
ASTM C42	“Standard Test Method for Obtaining and Testing Drilled Cores and Sawed Beams of Concrete”
ASTM C70	“Standard Test Method for Surface Moisture in Fine Aggregate”
ASTM C76	“Standard Specification for Reinforced Concrete Culvert, Storm Drain, and Sewer Pipe”
ASTM C94	“Standard Specification for Ready-Mixed Concrete”
ASTM C136	“Standard Test Method for Sieve Analysis of Fine and Coarse Aggregates”
ASTM C138	“Standard Test Method for Density (Unit Weight), Yield, and Air Content (Gravimetric) of Concrete”
ASTM C143	“Standard Test Method for Slump of Hydraulic Cement Concrete”
ASTM C150	“Standard Specification for Portland Cement”
ASTM C173	“Standard Test Method for Air Content of Freshly Mixed Concrete by the Volumetric Method”
ASTM C216	“Standard Specification for Facing Brick (Solid Masonry Units Made of Clay or Shale)”
ASTM C231	“Standard Test Method for Air Content of Freshly Mixed Concrete by the Pressure Method”
ASTM C260	“Standard Specification for Air-Entraining Admixtures for Concrete”
ASTM C330	“Standard Specification for Lightweight Aggregates for Structural Concrete”
ASTM C403	“Standard Test Method for Time of Setting of Concrete Mixtures by Penetration Resistance”

ASTM C443	“Standard Specification for Joints for Concrete Pipe and Manholes, Using Rubber Gaskets”
ASTM C478	“Standard Specification for Precast Reinforced Concrete Manhole Sections”
ASTM C494	“Standard Specification for Chemical Admixtures for Concrete”
ASTM C497	“Standard Test Methods for Concrete Pipe, Manhole Sections, or Tile”
ASTM C566	“Standard Test Method for Total Evaporable Moisture Content of Aggregate by Drying”
ASTM C595	“Standard Specification for Blended Hydraulic Cement”
ASTM C618	“Standard Specification for Fly Ash and Raw or Calcined Natural Pozzolan for Use in Concrete”
ASTM C642	“Standard Test Method for Density, Absorption, and Voids in Hardened Concrete”
ASTM C655	“Standard Specification for Reinforced Concrete D-Load Culvert, Storm Drain, and Sewer Pipe”
ASTM C685	“Standard Specification for Concrete Made by Volumetric Batching and Continuous Mixing”
ASTM C805	“Standard Test Method for Rebound Number of Hardened Concrete”
ASTM C890	“Standard Practice for Minimum Structural Design Loading for Monolithic or Sectional Precast Concrete Water and Wastewater Structures”
ASTM C913	“Standard Specification for Precast Concrete Water and Wastewater Structures”
ASTM C923	“Specification for Resilient Connectors Between Reinforced Concrete Manhole Structures, Pipes, and Laterals”
ASTM C979	“Standard Specification for Pigments for Integrally Colored Concrete”
ASTM C985	“Standard Specification for Nonreinforced Concrete Specified Strength Culvert, Storm Drain, and Sewer Pipe”
ASTM C989	“Standard Specification for Ground Granulated Blast-Furnace Slag for Use in Concrete and Mortars”

- ASTM C990 “Standard Specification for Joints for Concrete Pipe, Manholes, and Precast Box Sections Using Preformed Flexible Joint Sealants”
- ASTM C1017 “Standard Specification for Chemical Admixtures for Use in Producing Flowing Concrete”
- ASTM C1064 “Standard Test Method for Temperature of Freshly Mixed Portland Cement Concrete”
- ASTM C1088 “Standard Specification for Thin Veneer Brick Units Mad From Clay or Shale”
- ASTM C1116 “Standard Specification for Fiber-Reinforced Concrete and Shotcrete”
- ASTM C1157 “Standard Performance Specification for Hydraulic Cement”
- ASTM C1202 “Standard Test Method for Electrical Indication of Concrete’s Ability to Resist Chloride Ion Penetration”
- ASTM C1214 “Standard Test Method for Concrete Pipe Sewerlines by Negative Air Pressure (Vacuum) Test Method”
- ASTM C1227 “Standard Specification for Precast Concrete Septic Tanks”
- ASTM C1240 “Standard Specification for Silica Fume Used in Cementitious Mixtures”
- ASTM C1244 “Test Method for Concrete Sewer Manholes by the Negative Air Pressure (Vacuum) Test Prior to Backfill”
- ASTM C1433 “Specification for Precast Reinforced Concrete Monolithic Box Sections for Culverts, Storm Drains, and Sewers”
- ASTM C1478 “Standard Specification for Storm Drain Resilient Connectors Between Reinforced Concrete Storm Sewer Structures, Pipes and Laterals”
- ASTM C1577 “Specification for Precast Reinforced Concrete Monolithic Box Sections for Culverts, Storm Drains, and Sewers Design According to AASHTO LRFD”
- ASTM C1602 “Standard Specification for Mixing Water Used in the Production of Hydraulic Cement Concrete”
- ASTM C1610 “Standard Test Method for Static Segregation of Self-Consolidating Concrete Using Column Technique”
- ASTM C1611 “Standard Test Method for Slump Flow of Self-Consolidating Concrete”
- ASTM C1613 “Standard Specification for Precast Concrete Grease Interceptor Tanks”

- ASTM C1618 “Standard Test Method for Concrete Sanitary Sewer Pipe by Negative (Vacuum) or Positive Air Pressure”
- ASTM C1621 “Standard Test Method for Passing Ability of Self-Consolidating Concrete by J-Ring”
- ASTM C1628 “Standard Specification for Joints for Concrete Gravity Flow Sewer Pipe, Using Rubber Gaskets”
- ASTM C1712 “Standard Test Method of Static Segregation Resistance of Self-Consolidating Concrete Using Penetration Test”
- ASTM C1719 “Standard Test Method for Installed Precast Concrete Tanks and Accessories by the Negative Air Pressure (Vacuum) Test Prior to Backfill”
- ASTM C1758 “Standard Test Method for Fabricating Test Specimens with Self-Consolidating Concrete”
- ASTM C1778 “Standard Guide for Reducing Risk of Deleterious Alkali-aggregate reaction on Concrete”
- ASTM D2240 “Standard Test Method for Rubber Property—Durometer Hardness”
- ASTM E4 “Standard Practice for Force Verification of Testing Machines”
- ASTM G109 “Standard Test Method for Determining the Effects of Chemical Admixtures on the Corrosion of Embedded Steel Reinforcement in Concrete Exposed to Chloride Environments”

Additional Relevant Precast Concrete Product-Specific ASTM International standards (SI equivalents may also be applicable):

- ASTM C118 “Standard Specification for Concrete Pipe for Irrigation or Drainage”
- ASTM C172 “Standard Practice for Sampling Fresh Mixed Concrete”
- ASTM C192 “Standard Practice for Making and Curing Concrete Test Specimens in the Laboratory”
- ASTM C361 “Standard Specification for Reinforced Concrete Low-Head Pressure Pipe”
- ASTM C506 “Standard Specification for Reinforced Concrete Arch Culvert, Storm Drain, and Sewer Pipe”
- ASTM C507 “Standard Specification for Reinforced Concrete Elliptical Culvert, Storm Drain, and Sewer Pipe”

- ASTM C822 “Standard Terminology Relating to Concrete Pipe and Related Products”
- ASTM C825 “Standard Specification for Precast Concrete Barriers”
- ASTM C857 “Standard Practice for Minimum Structural Design Loading for Underground Precast Concrete Utility Structures”
- ASTM C858 “Standard Specification for Underground Precast Concrete Utility Structures”
- ASTM C877 “Standard Specification for External Sealing Bands for Concrete Pipe, Manholes, and Precast Box Sections”
- ASTM C915 “Standard Specification for Precast Reinforced Concrete Crib Wall Members”
- ASTM C923 “Standard Specification for Resilient Connectors Between Reinforced Concrete Manhole Structures, Pipes and Laterals”
- ASTM C1417 “Standard Specification for Manufacture of Reinforced Concrete Sewer, Storm Drain, and Culvert Pipe for Direct Design”
- ASTM C1479 “Standard Practice for Installation of Precast Concrete Sewer, Storm Drain, and Culvert Pipe Using Standard Installations”
- ASTM C1504 “Standard Specification for Manufacture of Precast Reinforced Concrete Three-Sided Structures for Culverts, and Storm Drains”
- ASTM C1603 “Standard Test Method for Measurement of Solids in Water”
- ASTM C1776 “Standard Specification for Wet-Cast Precast Modular Retaining Wall Units”
- ASTM C1786 “Standard Specification for Segmental Precast Reinforced Concrete Box Sections for Culverts, Storm Drains and Sewers Designed According to AASHTO LRFD”
- ASTM C1818 “Standard Specification for Rigid Synthetic Fiber Reinforced Concrete Culvert, Storm Drain, and Sewer Pipe”
- ASTM C1837 “Standard Specification for Production of Dry Cast Concrete Used for Manufacturing Pipe, Box, and Precast Structures”

ANSI STANDARDS

American National Standards Institute standards and other publications can be obtained from:

American National Standards Institute
 1819 L Street, NW
 6th floor
 Washington, DC 20036

Phone: .202-293-8020
Web: www.ansi.org

ANSI Standards cited in this manual:

ANSI A10.9 “Concrete and Masonry Work Safety Requirements”

ANSI A137.1 “American National Standards Specifications for Ceramic Tile”

AWS STANDARDS

American Welding Society standards and other publications can be obtained from:

American Welding Society
550 NW LeJeune Rd
Miami FL 33126
Phone: 800-443-9353
Web: www.aws.org

AWS Standards cited in this manual:

AWS D1.1 “Structural Welding Code -- Structural Steel”

AWS D1.4 “Structural Welding Code -- Reinforcing Steel”

AWS D1.5 “Bridge Welding Code”

CSA STANDARDS

CSA Group Head Office
178 Rexdale Blvd.
Toronto, Ontario
Canada M9W 1R3
Tel: 416-747-4000
Toll-Free: (800) 463-6727
www.csa-international.org

Plants required by provincial and/or local requirements may substitute the most recent version of the equivalent CSA standard to replace ASTM requirements in this manual.

CFR STANDARDS

Copies of the Code of Federal Regulations can be obtained from:

U.S. Government
Printing Office
732 North Capitol St. NW
Washington, DC 20401
Phone: 202-512-0000
Web: www.gpo.org

CFR Standards cited in this manual:

CFR Title 29 Part 1926 “Safety and Health Regulations for Construction”
(www.gpoaccess.gov/cfr/index.html)

CRSI STANDARDS

Concrete Reinforcing Steel Institute standards and other publications can be obtained from:

Concrete Reinforcing Steel Institute
933 N. Plum Grove Road
Schaumburg, IL 60173
Phone: 847-517-1200
Web: www.crsi.org

CRSI Standard cited in this manual:
“Placing Reinforcing Bars”

RSIC / IAAC STANDARDS

Reinforcing Steel Institute of Canada / Institut D’acier D’armature du Canada standards and other publications can be obtained from:

Reinforcing Steel Institute of Canada / Institut D’acier D’armature
du Canada
P O Box 40620
RPO Six Points Plaza
Toronto, Ontario M9B 6K8
(416) 239-RSIO (7746)

RSIC / IAAC Standard cited in this manual:
“REINFORCING STEEL – Manual of Standard Practice”

REFERENCES

National Precast Concrete Association

“Techfiles: A Collection of NPCA Technotes and Techbriefs”

“NPCA Guide to Implementing SCC”

National Precast Concrete Association
10333 North Meridian Street, Suite 272
Indianapolis, IN 46290
Phone: 800-366-7731
Web: www.precast.org

- ACI 116 "Cement and Concrete Terminology"
- ACI 212.2 "Guide for the Use of Admixtures in Concrete"
- ACI 301 "Specifications for Structural Concrete for Buildings"
- ACI 308 "Practice for Curing Concrete"
- ACI 309 "Guide for Consolidation of Concreting"
- ACI 311.1 "ACI Manual of Concrete Inspection"
- NPCA "NPCA Guide to Implementing SCC"

AMERICAN CONCRETE PIPE ASSOCIATION

ACPA
8445 Freeport Parkway
Suite 350
Irving, TX 75063-2595
Phone: 972-506-7216
Web: www.concrete-pipe.org

QCast Plant Certification Manual

PORTLAND CEMENT ASSOCIATION

Portland Cement Association
5420 Old Orchard Road
Skokie IL 60077
Phone: 847-966-6200
Web: www.cement.org

PCA EB001.16 "Design and Control of Concrete Mixtures"

PCA PA 015 "Tips on Control Tests for Quality Concrete"

"Quality is Free -- The Art of Making Quality Certain" by Phillip B. Crosby
Mentor Book, New American Library
PO Box 999
Bergenfield, NJ 07621

"Concrete Manual" Part 2, 9th ed
NTIS (National Technical Information Services)
US Dept Commerce
Springfield VA 22161
800-553-6847

PCI

Prestressed Concrete Institute
175 W. Jackson Blvd.
Chicago, IL 60604
Phone: 312-786-0300
Web: www.pci.org

PCI MNL-116 “Manual for Quality Control for Plants and Production of Structural
Precast Concrete Products”

PCI MNL-117 “Manual for Quality Control for Architectural Precast Concrete”

APPENDIX B

SAMPLE FORMS

Standardized forms are useful for recording and keeping information. Industry-wide forms are too often cumbersome for most plants, so it is recommended that each plant develop forms applicable to its operations and products. The basic principle in developing forms is to make each form complete but as simple as possible. The forms included in this appendix are examples of those being used in the precast concrete products industry.

RAW MATERIAL REPORT

QUALITY CONTROL DEPARTMENT

Job No _____

Job Name _____

FINE AGGREGATE

Sieve Size	Weight Retained	% Retained	% Passing	ASTM C 33 % Passing
3/8"				100
No. 4				95-100
No. 8				80-100
No. 16				50-85
No. 30				25-60
No. 50				5-30
No. 100				0-10
Pan				0-3
Fineness Modulus				

COARSE AGGREGATE

Sieve Size	Weight Retained	% Retained	% Passing	ASTM C 33 size 67 % Pass	ASTM C33 size 8 % Pass
1"				100	0
3/4"				90-100	0
1/2"				0	100
3/8"				20-55	85-100
No. 4				0-10	10-30
No. 8				0-5	0-10
No. 16				0	0-5

Date _____

Technician _____

Inspector _____

PRE-POUR INSPECTION REPORT

QUALITY CONTROL DEPARTMENT

PRODUCT:	Job #						
Casting Date							
Casting Number							
Form Number							
Form Condition							
Form Cleanliness							
Form Joints							
Release Agent/Retarder							
Design Length (ft/in)							
Set-Up Length (ft/in)							
Design Width (ft/in)							
Set-Up Width (ft/in)							
Design Depth (ft/in)							
Set-Up Depth (ft/in)							
Blockouts							
Squareness							
End and Edge Details							
Reinforcing Steel -Design v Actual							
Size of Reinforcing Design v Actual							
Spacing of Reinforcing Design v Actual							
Corrosion							
Reinf. Cleanliness							
Plates and Inserts							
Location of Lifting Devices							
Top Finish (wet)							

* All applicable boxes shall have actual measurements or actual condition noted, otherwise shall be marked n/a

REMARKS:

QC Supervisor _____

Date _____

Inspector _____

CONCRETE TESTING REPORT

QUALITY CONTROL DEPARTMENT

JOB NUMBER _____

JOB NAME _____

PRODUCT:				DATE:			
Slump or Slump Flow & VSI							
Air %							
Ambient Temperature							
Concrete Temperature							
Mix Design No.							
Cylinder No.							
Strength Test Date							
Time Made							
Time of Strength Test							
Curing Age							
Load (lbs)							
Strength (psi)							
Required Strength (psi)							

REMARKS: _____

Report

Inspector _____

Date _____

QC Supervisor _____

Signature _____

Signature _____

POST-POUR INSPECTION REPORT

QUALITY CONTROL DEPARTMENT

PRODUCT:		Job #:					
Casting Date							
Casting Number							
Inspection Date							
Mark Number							
Stripping Strength							
Top Finish							
Bottom Finish							
Surface Texture							
As Cast Length (ft/in)							
As Cast Width (ft/in)							
As Cast Depth (ft/in)							
Cracks							
Spalls							
Squareness							
Chamfers							
Honeycomb / Grout Leak							
Bowing							
Exposed Reinforcement							
Exposed Chairs							
Plates and Inserts							
Radius Quality							
Openings / Blockouts							
Lifting Devices							
Form Condition							

* All applicable boxes shall have actual measurements or actual condition noted, otherwise shall be marked n/a.

REMARKS:

Inspector _____

Date _____

QC Supervisor _____

Batch Report Form

Batch Report Form

Mix Designation: _____ Date: _____
 Quantity: _____ Time: _____
 Batch Operator: _____
 Project/Job: _____

Material	Quantity	
Cement:	_____ lbs.	Type: _____
SCM	_____ lbs.	
Water:	_____ gal./lbs.	
Fine Aggregate:	_____ lbs.	Type: _____
Coarse Aggregate:	_____ lbs.	Type: _____
Air Entrainment:	_____ ozs.	Type: _____
Water Reducer:	_____ ozs.	Type: _____
Other:	_____	Type: _____
Fine Agg. Moisture:	Free or Total	_____ %
Coarse Agg. Moisture:	Free or Total	_____ %
w/cm Ratio:	_____	

Mix Designation: _____ Date: _____
 Quantity: _____ Time: _____
 Batch Operator: _____
 Project/Job: _____

Material	Quantity	
Cement:	_____ lbs.	Type: _____
SCM	_____ lbs.	
Water:	_____ gal./lbs.	
Fine Aggregate:	_____ lbs.	Type: _____
Coarse Aggregate:	_____ lbs.	Type: _____
Air Entrainment:	_____ ozs.	Type: _____
Water Reducer:	_____ ozs.	Type: _____
Other:	_____	Type: _____
Fine Agg. Moisture:	Free or Total	_____ %
Coarse Agg. Moisture:	Free or Total	_____ %
w/cm Ratio:	_____	

Optional QC Information

Slump: _____ in. Temp. _____
 Slump Flow: _____ in.
 VSI _____
 Air Content: _____ %
 Comp. Strength: _____ psi
 Density (Unit Weight) _____ lb/ft³

Optional QC Information

Slump: _____ in. Temp. _____
 Slump Flow: _____ in.
 VSI _____
 Air Content: _____ %
 Comp. Strength: _____ psi
 Density (Unit Weight) _____ lb/ft³

GASKET QUALITY CONTROL REPORT

Test Number _____

Product Gaskets will be used on _____

Vendor _____

Qty. Ordered _____

Vendor Order # _____

Plant P.O.# _____

Date Received _____

Critical Gasket Dimension Table						
Gasket #	Durometer	Length	Dia./Width	Height	Volume	Splice Strength
Measured						
1						
2						
3						
4						
5						
6						
7						
8						
9						
10						
Required						

Printed Marking on Gasket _____

Gasket Compliance Status Meets Spec. Does not meet Spec.

Signed _____

Date _____

Remarks: _____

CONCRETE PIPE DIMENSIONAL INSPECTION FORM

Date _____

Pipe Size _____

Job # _____

Pipe Class _____

Lot # _____

Pipe Wall _____

Pipe # _____

Mfg. Process _____

Produced _____

Internal Diameter

Position	Spigot End	Bell End	Required
0°	_____	_____	_____
180°	_____	_____	_____

Wall Thickness

Position	Spigot End	Bell End	Required
0°	_____	_____	_____
90°	_____	_____	_____
180°	_____	_____	_____
270°	_____	_____	_____

Length Measurements

Position	Length Measurement	Measurements	Required
0°	_____	Maximum Length _____	_____
90°	_____	Minimum Length _____	_____
180°	_____	Range _____	_____
270°	_____		

Signed _____

Date _____

REINFORCED CONCRETE PIPE THREE-EDGE-BEARING TEST REPORT (ASTM C497)

Test # _____

x

PRODUCT INFORMATION

Type	Size	Class	Wall	Joint

Test Date _____

Manufacture Date _____

Product Age (days) _____

Manufacturing Process _____

Length		
	Measured	Allowable
Min.		
Max.		

Wall Thickness		
	Measured	Allowable
Min.		
Max.		N/A

Inside Diameter		
	Measured	Allowable
Min.		
Max.		

REINFORCING INFORMATION

Cage	Description	Area of Steel	Required Area of Steel
Inside:			
Outside:			
Elliptical:			

Comments: _____

THREE-EDGE-BEARING TEST RESULTS

	Actual Load	Required Load	Actual D-Load	Required D-Load
1st Crack				
.01" Crack				
Ultimate				

If Product was not tested to Ultimate Load:

Load when test was stopped: _____ lbs.

D-Load when test was stopped: _____ lbs/ft

Pipe condition when test was stopped:

I hereby certify that the pipe was tested in accordance with ASTM C497.

Signature: _____

Date: _____

SINGLE CELL BOX CULVERT REINFORCEMENT INSPECTION

Date: _____

Inspector: _____

Comments: _____

Identification
Fabrication Date
Span
Rise
Design Table #
Earth Cover, Min.
Earth Cover, Max.

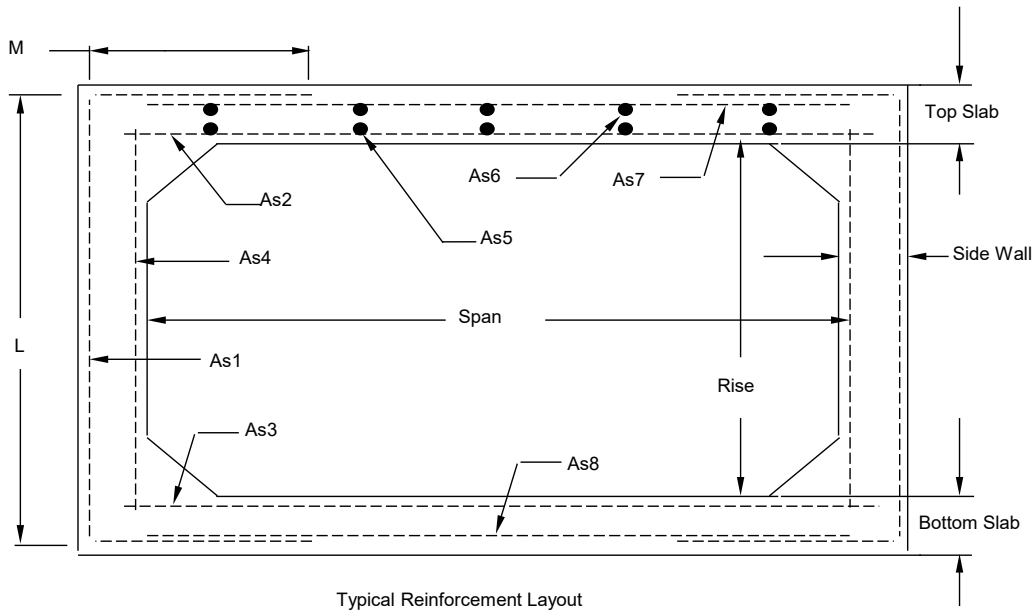

	Area of Steel Used	Area of Steel Required	Mesh Type	Length	M
As1					
As2					
As3					
As4					
As5					
As6					
As7					
As8					
Inserts					
Spacers					
*Lap					

DOUBLE CELL BOX CULVERT REINFORCEMENT INSPECTION

Date: _____

Inspector: _____

Comments: _____

Identification	
Fabrication Date	_____
Span	_____
Rise	_____
Design Table #	_____
Earth Cover, Min.	_____
Earth Cover, Max.	_____

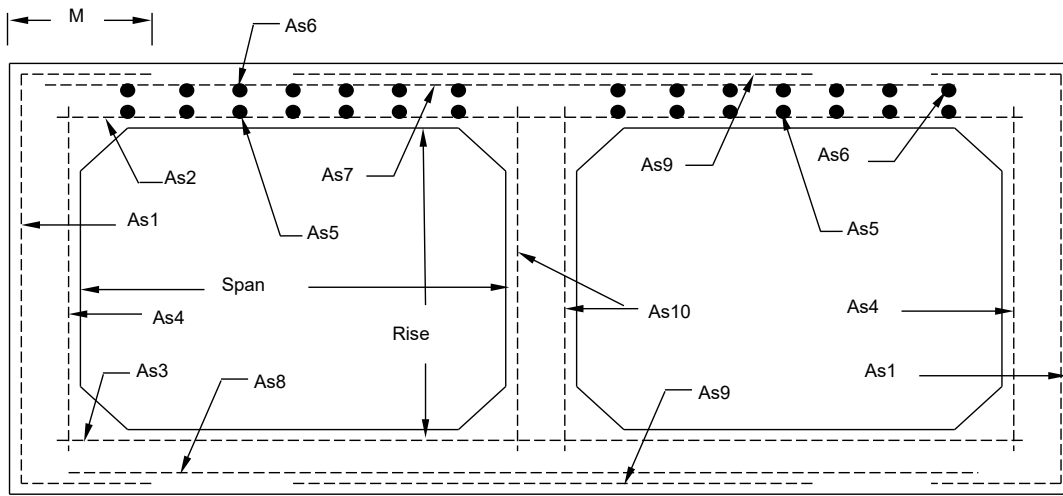

Typical Reinforcement Layout

	Area of Steel Used	Area of Steel Required	Mesh Type	Length	M
A _s 1					
A _s 2					
A _s 3					
A _s 4					
A _s 5					
A _s 6					
A _s 7					
A _s 8					
A _s 9					
A _s 10					
Inserts					
Spacers					
*Lap					

REINFORCING STEEL INSPECTION TEMPLATE

Company Name and Info

QUALITY CONTROL DEPARTMENT
QUALITY ASSURANCE

ASTM C-478 SPECS (OR SPEC FOLLOWED)

DATE OF INSPECTION _____

ITEM NO.	DESCRIPTION	REBAR SIZE AND SPACING		ALLOWABLE SPACING		REBAR GRADE		OVERLAP LENGTH		REINFORCEMENT COVER		WELD INSPECTION (IF APPLICABLE) OR
		DESIGN	ACTUAL	DESIGN	ACTUAL	DESIGN	ACTUAL	DESIGN	ACTUAL	DESIGN	ACTUAL	
1	(VAULT LID 6-6" X 6-6" SQ X 8 ")	# 5 - 8" O.C./E.W.	# 5 - 8" O.C./E.W.	(+/-1 ")	1" < X	GD 60/420	GD 60/420	12"	12"	2" MIN	2.5 "	INSPECTED
2												
3												
4												
5												
6												
7												
8												
9												
10												
11												
12												
13												
14												
15												
16												
17												
18												
19												
20												
21												

30" ϕ MH GRADE RING

JOB#: _____

STACK 6 PER SKID

JOB: _____

GRADE SIZE: 6"

DRAWN BY: _____

SMOOTH BAR HOOP STEEL		
SIZE	ϕ	QTY
#2	3'-2"	1
1" CHAIRS		

SCC #8 STONE

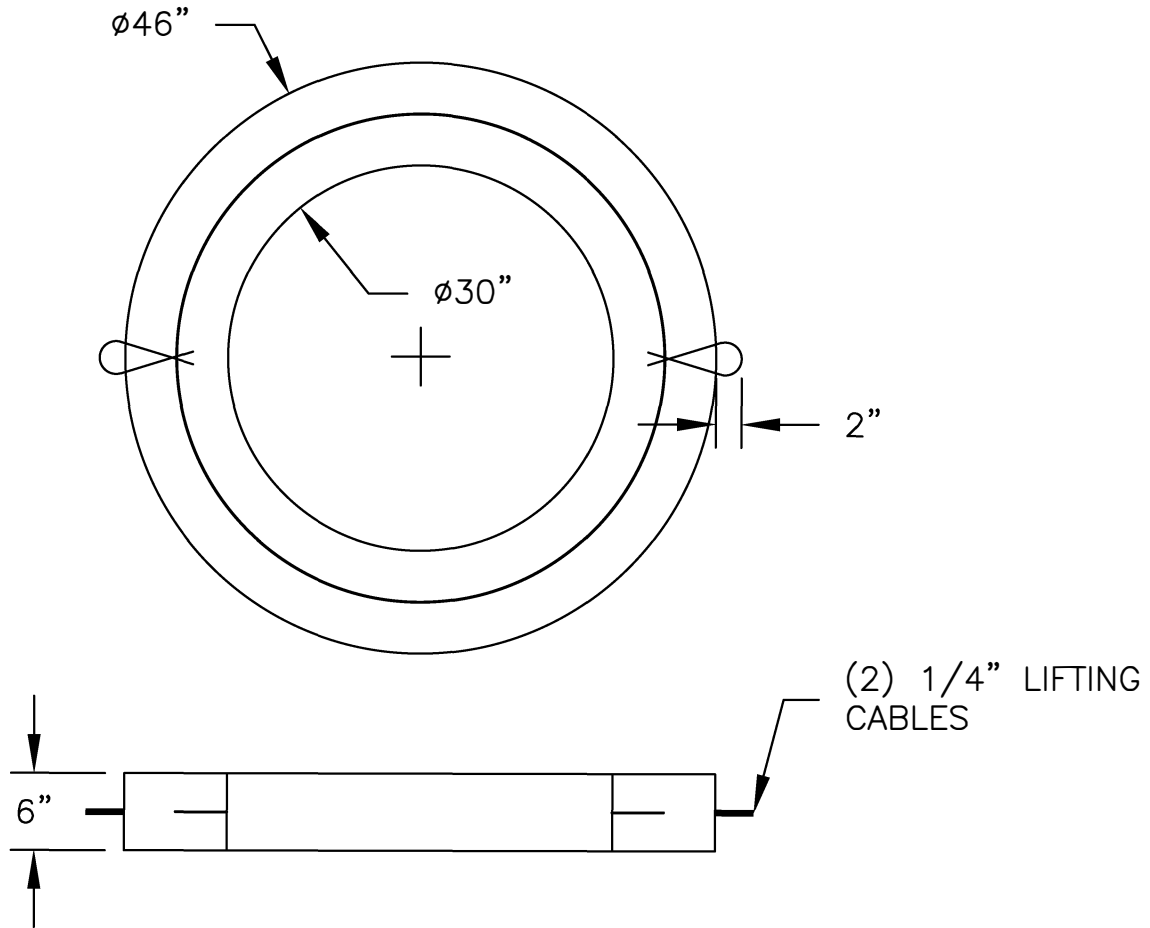

QC REBAR CHECKLIST

SIZE: _____
 LENGTH: _____
 TYPE: _____
 COVER: _____
 CHECKED: _____

WEIGHT: 314#

RED HAT FINISH
& LIFTERS: _____

DIMENSIONAL TOLERANCES

LENGTH, WIDTH, HEIGHT, WALL THICKNESS: $\pm 1/2"$
 REBAR SPACING: $\pm 1"$
 CONCRETE COVER OVER REINFORCING: $-0", +1/2"$
 HOLE LOCATION: $\pm 1"$
 HOLE SIZE: $\pm 1/2"$

SET BY: _____

MOLD DIMS &
PRE POUR: _____

POST POUR: _____

POUR DATE: _____

48" ϕ x 48" CONCENTRIC CONE

JOB: _____ JOB#: _____

MANHOLE NUMBER: _____ STEEL CENTERED IN PRODUCT

HOOP STEEL:

- (1) 30" x $\frac{1}{4}$ " WIRE
- (1) 50" x $\frac{1}{4}$ " WIRE
- (1) 52" x $\frac{1}{4}$ " WIRE

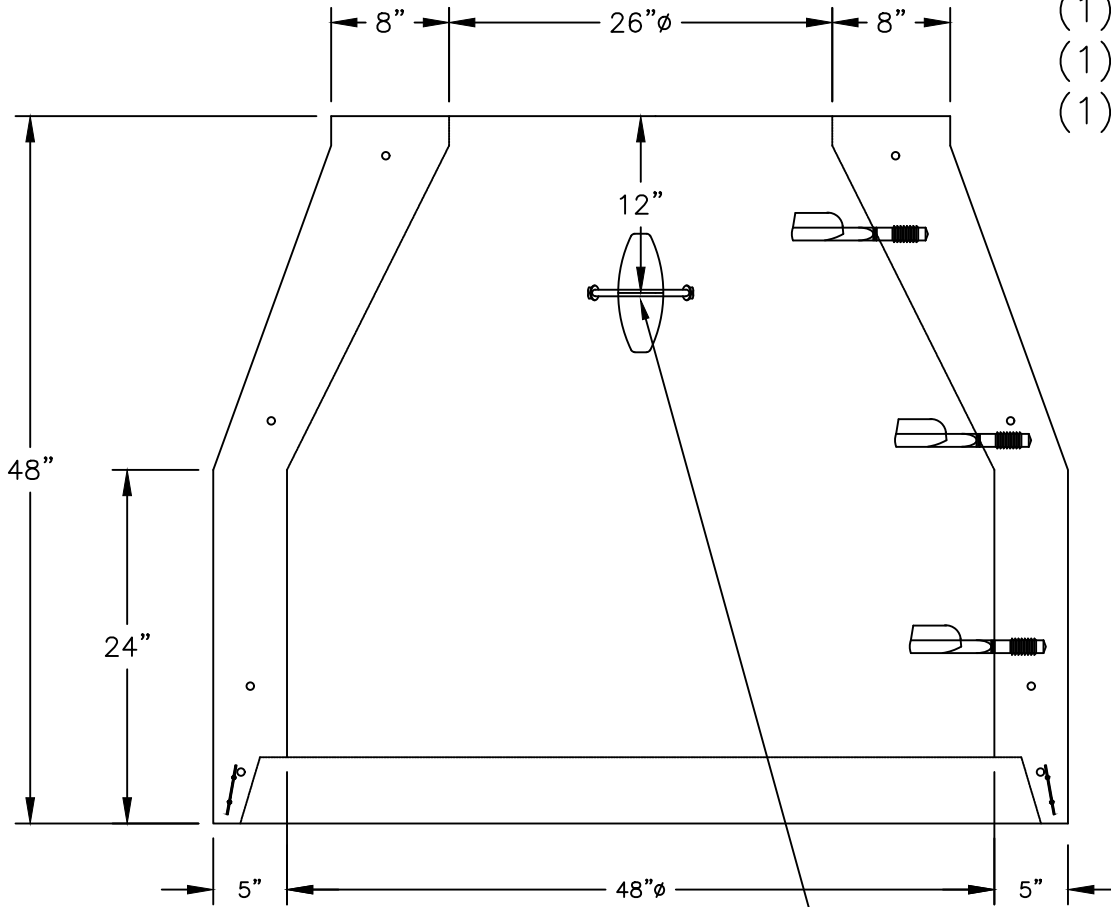

(2) 4 TON UTIL. ANCHORS
180° APART 90° OFF STEP LOCATION

- 4' MANHOLE 3X8 WIRE
IN PALLET W/HOOP

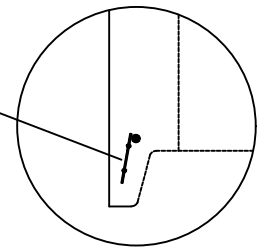

QC REBAR CHECKLIST

SIZE: _____

LENGTH: _____

TYPE: _____

COVER: _____

CHECKED: _____

* NOTE: FABRICATE TO ASTM C478

SHOP USE

FORM #: _____ SET UP: _____ DATE POURED: _____

DRAWN BY: DWM mold dims
& pre-pour: _____ POST POUR: _____

OFFICE USE ONLY

TOTAL: _____ FLAT TOP: _____ 64" RISER: _____ 24" RISER: _____

CASTING: _____ TRANSITION: _____ 48" RISER: _____ 12"/16" RISER: _____

CONE: _____ BASE: _____ 32" RISER: _____ OTHER: _____

OFFICE CHECK: _____ ADJUST: _____

6' x 8' VAULT TOP

JOB: _____ FINISH: N/A JOB#: _____

PIECE NUMBER: _____ LIFTING DEVICE: (4) 6/6 U.L.

VAULT SIZE: 72"x96"x78" STEEL: SEE ATTACHED

WALL THICKNESS: 6" CHAIR SIZE: _____

MOLD DIMS & RED HAT FINISH
PRE POUR: _____ & LIFTERS: _____ POST POUR: _____ POUR DATE: _____

DRAWN BY: _____

CH'D BY: _____

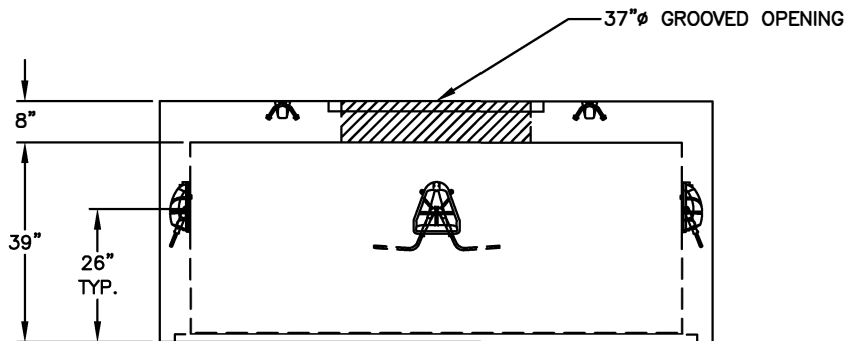
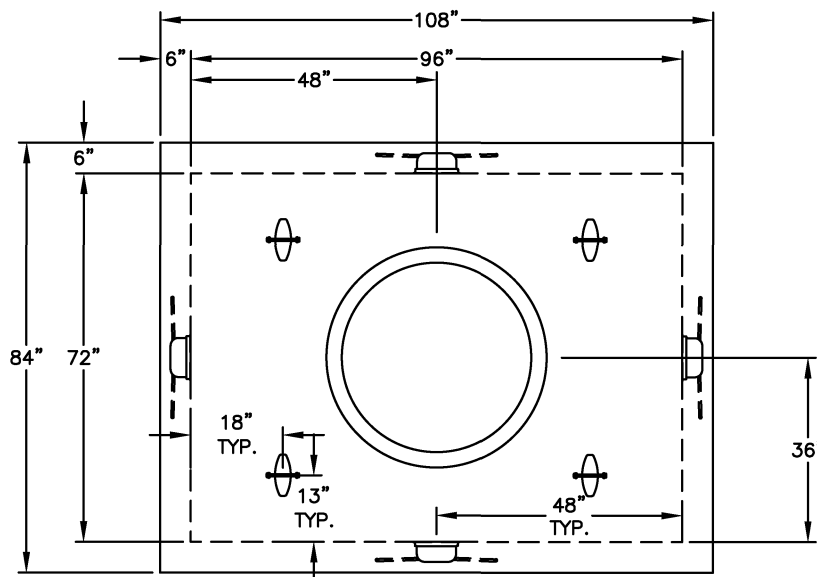

QC REBAR CHECKLIST

SIZE: _____
 LENGTH: _____
 TYPE: _____
 COVER: _____
 CHECKED: _____

DIMENSIONAL TOLERANCES

LENGTH, WIDTH, HEIGHT, WALL THICKNESS: $\pm 1/2"$
 REBAR SPACING: $\pm 1"$
 CONCRETE COVER OVER REINFORCING: $-0", +1/2"$
 HOLE SIZE: $\pm 1/2"$

OFFICE CHECK: _____

WEIGHT: 13,620 #

6' x 8' VAULT TOP REBAR

JOB: _____ FINISH: N/A JOB#: _____

PIECE NUMBER: _____ LIFTING DEVICE: (4) 6/6 U.L.

VAULT SIZE: 72"x96"x78" STEEL: SEE ATTACHED

WALL THICKNESS: 6" CHAIR SIZE: _____

MOLD DIMS & RED HAT FINISH
PRE POUR: _____ & LIFTERS: _____ POST POUR: _____ POUR DATE: _____

DRAWN BY: _____
CH'D BY: _____

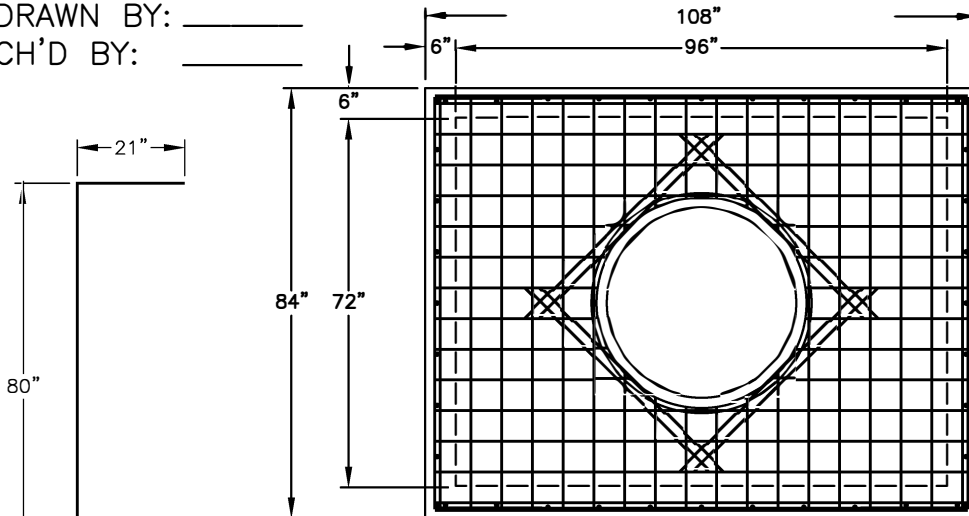

REBAR		
QTY.	BAR SIZE	LENGTH
12	#5 BAR	6'-8"
4	#5 BAR	2'-2"
4	#5 BAR	1'-10"
4	#5 BAR	1'-8"
8	#4 BAR	8'-8"
4	#4 BAR	3'-2"
4	#4 BAR	2'-10"
4	#4 BAR	2'-8"
DIAG		
4	#4 BAR	4'-3"
WALLS		
10	#4 BAR	10'-2" BENT
10	#4 BAR	8'-8"
40	#4 BAR	5'-2" BENT

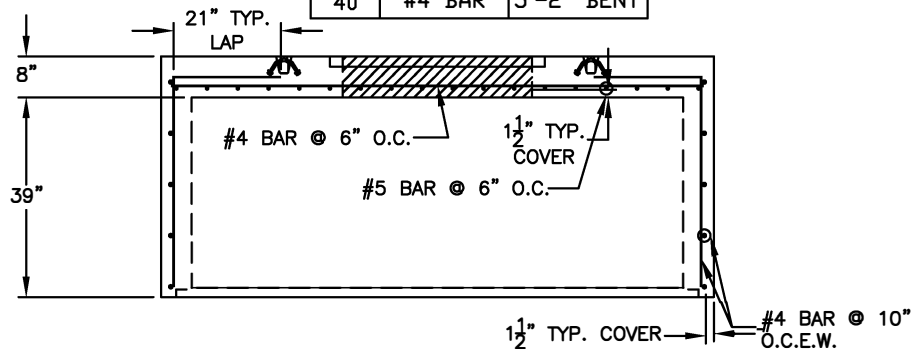
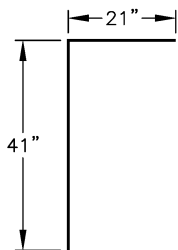

QC REBAR CHECKLIST

SIZE: _____
 LENGTH: _____
 TYPE: _____
 COVER: _____
 CHECKED: _____

*METHOD(S) OF RIGID REINFORCEMENT
 SUPPORT/CONNECTION: _____

DIMENSIONAL TOLERANCES

LENGTH, WIDTH, HEIGHT, WALL THICKNESS: $\pm 1/2"$
 REBAR SPACING: $\pm 1"$
 CONCRETE COVER OVER REINFORCING: $-0", +1/2"$
 HOLE SIZE: $\pm 1/2"$

OFFICE CHECK: _____

WEIGHT: 13,620 #

6' x 8' VAULT BASE

JOB: _____ FINISH: N/A JOB#: _____

PIECE NUMBER: _____ LIFTING DEVICE: (6) 8T S.L./ (4) 6/6 U.L.

VAULT SIZE: 72"x96"x78" STEEL: SEE ATTACHED

WALL THICKNESS: 6" CHAIR SIZE: 1 1/2"

MOLD DIMS & RED HAT FINISH
PRE POUR: _____ & LIFTERS: _____ POST POUR: _____ POUR DATE: _____

DRAWN BY: _____

CH'D BY: _____

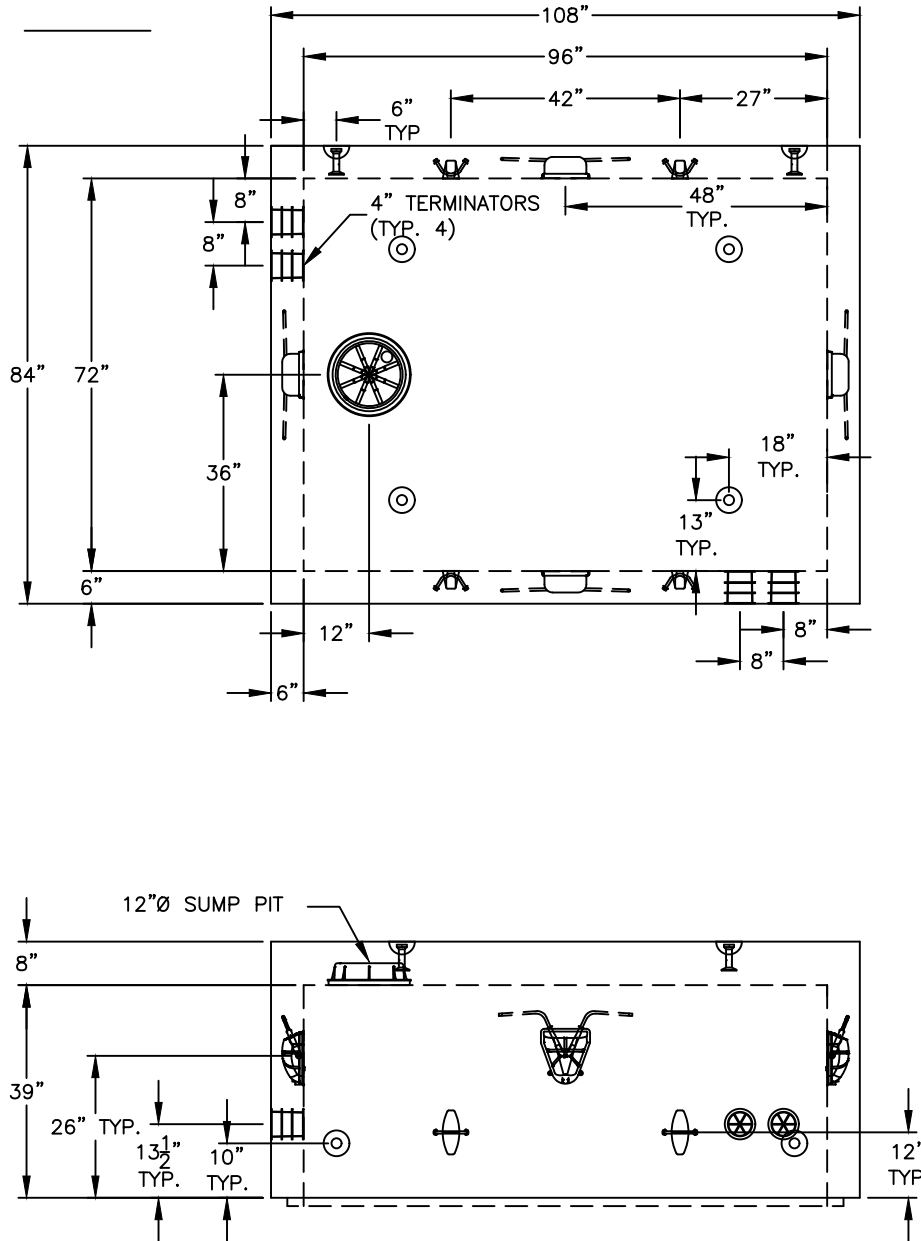

QC REBAR CHECKLIST

SIZE: _____
 LENGTH: _____
 TYPE: _____
 COVER: _____
 CHECKED: _____

DIMENSIONAL TOLERANCES

LENGTH, WIDTH, HEIGHT, WALL THICKNESS: $\pm 1/2"$
 REBAR SPACING: $\pm 1"$
 CONCRETE COVER OVER REINFORCING: $-0", +1/2"$
 HOLE SIZE: $\pm 1/2"$

OFFICE CHECK: _____

WEIGHT: 13,620 #

6' x 8' VAULT BASE REBAR

JOB: _____ FINISH: N/A JOB#: _____

PIECE NUMBER: _____ LIFTING DEVICE: (6) 8T S.L./ (4) 6/6 U.L.

VAULT SIZE: 72"x96"x78" STEEL: SEE ATTACHED

WALL THICKNESS: 6" CHAIR SIZE: 1 1/2"

MOLD DIMS & RED HAT FINISH
PRE POUR: _____ & LIFTERS: _____ POST POUR: _____ POUR DATE: _____

DRAWN BY: _____

CH'D BY: _____

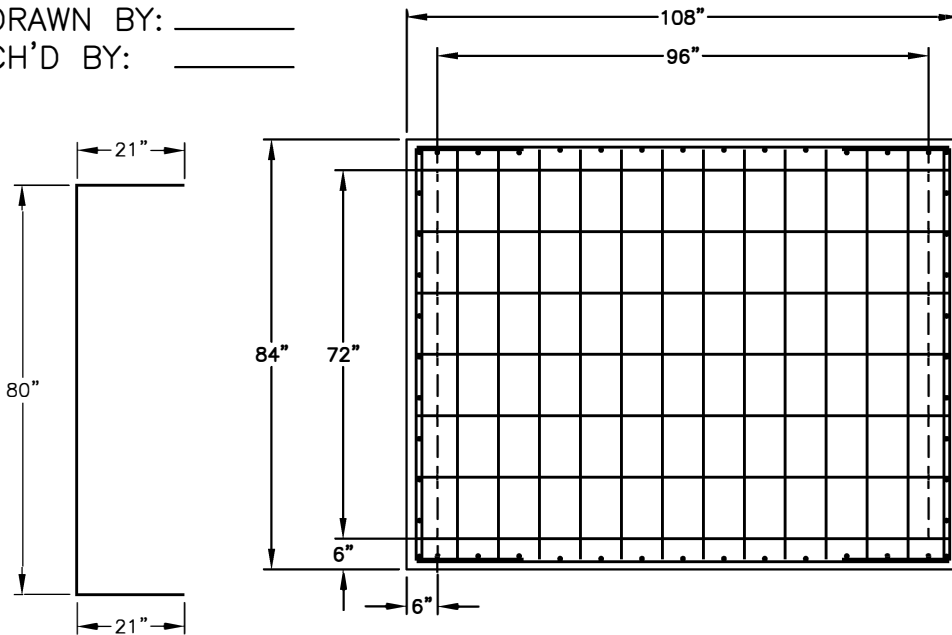

REBAR		
TOP MAT		
7	#4 BAR	8'-8"
14	#4 BAR	6'-8"
WALLS		
12	#4 BAR	10'-2" (BENT)
12	#4 BAR	8'-8"
48	#4 BAR	5'-2" (BENT)

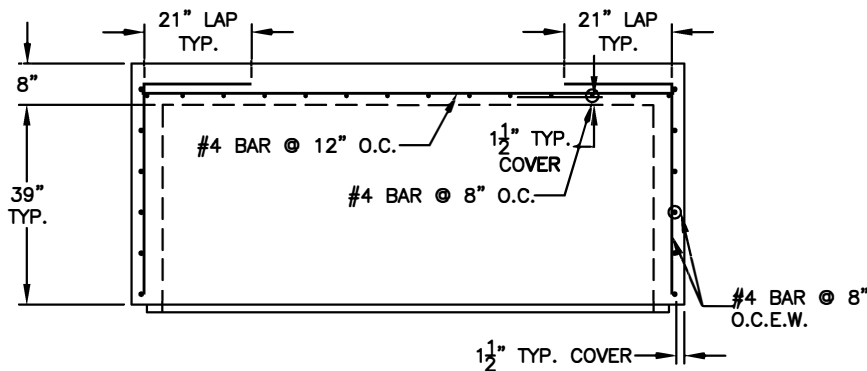
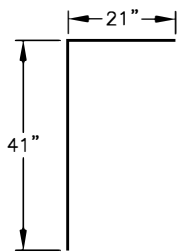

QC REBAR CHECKLIST

SIZE: _____
 LENGTH: _____
 TYPE: _____
 COVER: _____
 CHECKED: _____

*METHOD(S) OF RIGID REINFORCEMENT
 SUPPORT/CONNECTION: _____

DIMENSIONAL TOLERANCES

LENGTH, WIDTH, HEIGHT, WALL THICKNESS: $\pm 1/2"$
 REBAR SPACING: $\pm 1"$
 CONCRETE COVER OVER REINFORCING: $-0", +1/2"$
 HOLE SIZE: $\pm 1/2"$

OFFICE CHECK: _____

WEIGHT: 13,620 #

MIX QUALIFICATION FORM

Formula Number: _____ Plant: _____

Formula Name: _____

Design Compressive Strength: _____ PSI @ 28 days

Water-to-Cementitious Ratio: _____ Design Air Content: _____ %

Design Unit Weight, Batched: _____ PCF Coarse Aggregate Ratio: _____

Cement (type ____): _____ LBS. Supplier: _____

Fly Ash: _____ LBS. (Fly Ash % = ____) Supplier: _____

Water: _____ LBS. _____ GAL.

Coarse Aggregate: _____ LBS. (SSD) (Type: _____)

Sand: _____ LBS. (SSD) (Type: _____)

Air Entrainment Admixture: _____ OZ. (Name: _____)

Water Reducing Admixture: _____ OZ (Name: _____)

Set Accelerating Admixture: _____ OZ (Name: _____)

***Attach the sieve analysis and mill reports for the raw materials used.*

Plastic Test Documentation:

Time: _____ Ambient / Air Temperature: _____ °F Dew Point: _____ °F

Slump: _____ inches

Unit Weight: _____ PCF Air Content: _____ % Concrete Temperature: _____ °F

Compressive Test Documentation:

@ 1 Days: Cylinder 1: _____ PSI Cylinder 2: _____ PSI Average: _____ PSI

@ 3 Days: Cylinder 1: _____ PSI Cylinder 2: _____ PSI Average: _____ PSI

@ 7 Days: Cylinder 1: _____ PSI Cylinder 2: _____ PSI Average: _____ PSI

@28 Days: Cylinder 1: _____ PSI Cylinder 2: _____ PSI Average: _____ PSI

Acceptance Criteria:

Slump: Minimum: _____ inches – Maximum: _____ inches

Unit Weight: _____ ±2 pounds per cubic foot

Air Content: _____ ±1.5%

Minimum Stripping Strength: _____ PSI

Minimum Shipping Strength: _____ PSI

Minimum 28 Day Required Strength: _____ f'_{cr}

Mix Design Approval:

Engineering Date

Production Date

Quality Date

SCC MIX QUALIFICATION FORM

Formula Number: _____ Plant: _____

Formula Name: _____

Design Compressive Strength: _____ PSI @ 28 days

Water-to-Cementitious Ratio: _____ Design Air Content: _____ %

Design Unit Weight, Batched: _____ PCF Coarse Aggregate Ratio: _____

Cement (type ____): _____ LBS. Supplier: _____

Fly Ash: _____ LBS. (Fly Ash % = ____) Supplier: _____

Water: _____ LBS. _____ GAL.

Coarse Aggregate: _____ LBS. (SSD) (Type: _____)

Sand: _____ LBS. (SSD) (Type: _____)

Air Entrainment Admixture: _____ OZ. (Name: _____)

Water Reducing Admixture: _____ OZ (Name: _____)

Set Accelerating Admixture: _____ OZ (Name: _____)

***Attach the sieve analysis and mill reports for the raw materials used.*

Plastic Test Documentation:

Time: _____ Ambient / Air Temperature: _____ °F Dew Point: _____ °F

Slump Flow: _____ inches T₅₀: _____ seconds Visual Stability Index (VSI): _____

Unit Weight: _____ PCF Air Content: _____ % Concrete Temperature: _____ °F

Compressive Test Documentation:

@ 1 Days: Cylinder 1: _____ PSI Cylinder 2: _____ PSI Average: _____ PSI

@ 3 Days: Cylinder 1: _____ PSI Cylinder 2: _____ PSI Average: _____ PSI

@ 7 Days: Cylinder 1: _____ PSI Cylinder 2: _____ PSI Average: _____ PSI

@28 Days: Cylinder 1: _____ PSI Cylinder 2: _____ PSI Average: _____ PSI

Acceptance Criteria:

Slump Flow: Minimum: _____ inches – Maximum: _____ inches

Visual Stability Index (VSI): ≤1

Unit Weight: _____ ±2 pounds per cubic foot

Air Content: _____ ±1.5%

Minimum Stripping Strength: _____ PSI

Minimum Shipping Strength: _____ PSI

Minimum 28 Day Required Strength: _____ f'_{cr}

Mix Design Approval:

Engineering Date

Production Date

Quality Date

Manufacturers Name & Logo

Date of Document: _____

CERTIFICATE of COMPLIANCE

Product Name or Description: _____

This is to certify that the above lifting and handling product has been manufactured and tested in accordance with the quality control plan established by _____ and meets or exceeds OSHA 29 CFR 1926.704 when compared to the listed catalog rating for the lifting device.

This document certifies each manufactured product can be related to a quality control plan. The manufacturing quality control tests can be made available upon written request and when appropriate.

The rated capacities are for mechanical capacity of the listed anchor or insert only. Placement, edge distances, embedment depth, concrete strength, attachment device, sling angles, and rigging consideration are not part of this certificate of compliance.

Name, Signature, Title and Date of Company Authorized Agent

Title: _____ Date: _____

Tank Watertighness Testing Data Sheet

Date Tested: _____

Location of Test: _____

Type of Product Tested: _____

Test Specifications: _____

Septic Tank ASTM C1227

Vacuum Testing per Subsection 9.2.1

Start Reading: _____ End Reading: _____ Hold Time: _____

Pass: _____ Fail: _____

Water Pressure Testing per Subsection 9.2.2

Start Time: _____ End Time: _____ Refill: Yes / No Hold Time: _____

Pass: _____ Fail: _____

Grease Interceptor ASTM C1613

Vacuum Testing per Subsection 9.1.1

Start Reading: _____ End Reading: _____ Hold Time: _____

Pass: _____ Fail: _____

Hydrostatic Testing per Subsection 9.2.2

Start Time: _____ End Time: _____ Refill: Yes / No Hold Time: _____

Pass: _____ Fail: _____

Comments: _____

Test Performed by: _____

Test Witnessed by: _____

PLANT TERMS AND CONDITIONS

NPCA PLANT CERTIFICATION and OPTIONAL PRODUCT LISTING FOR WATER and WASTEWATER TANKS

PART 1

PURPOSE, SCOPE, SUBMITTALS AND AUDITS

1.1 Purpose

- 1.1.1 To assure a uniformly high degree of excellence in plant facilities, production, procedures, and quality control operations.
- 1.1.2 To assist management in achieving excellence in plants and operations.
- 1.1.3 To provide recognition for plants which achieve a high degree of excellence.
- 1.1.4 To assist users and specifiers of precast identify and select high quality precast concrete manufacturers.

1.2 Scope

- 1.2.1 The Plant Certification Programs outlined herein are directed at certifying that plant processes are in place to produce precast concrete products with a high degree of excellence.
- 1.2.2 The NPCA Certification programs certify the precast plants processes.
- 1.2.3 The NPCA Product Listing program certifies that water and wastewater tanks meet the requirements of applicable industry standards.
- 1.2.4 Plants making application for product listing must be an NPCA plant is good standing and hold a current NPCA Plant Certification.

1.3 Submittal

- 1.3.1 The submittal consists of a complete document package that includes detailed and stamped structural engineering design calculations for the precast concrete water or wastewater tank and a complete set of details illustrating compliance with all sections of the applicable industry standard (ASTM C913, IAPMO/ANSI Z1002, or ASTM C1227, IAPMO/ANSI Z1000 or ASTM C1613, IAPMO/ANSI Z1001).

1.4 Plant Inspections

- 1.4.1 A plant qualifies as an NPCA Certified Plant if it meets or exceeds the required level of excellence during the initial announced inspection and subsequent annual unannounced inspections. Plants shall remain certified if all necessary fees are paid and the plant attains the minimum score on each annual audit.

PART 2

ADMINISTRATION OF NPCA PLANT CERTIFICATION and OPTIONAL PRODUCT LISTING FOR WATER and WASTEWATER TANKS

2.1 Administrators

The administrators of the programs will be members of the NPCA staff. The duties of the administrators include but are not limited to:

- 2.1.1 Members of the NPCA Technical Staff, Certification & Technical Services Administrator, Technical Services Engineer, Director of Quality Assurance Programs are responsible for implement the policies and directives issued by the NPCA Quality Assurance Committee, which oversees the NPCA Plant Certification.
- 2.1.2 Members of the NPCA Technical Staff, Technical Services Engineers & Director of Quality Assurance Programs are responsible for the review and approval of plant submittal packages to the program.
- 2.1.3 Maintain the files generated by the programs.
- 2.1.4 Maintain and distribute current lists of NPCA Certified Plants
- 2.1.5 Coordinate scheduling of audits with plants and audit agency.
- 2.1.6 Serve as treasurer for the programs by initiating invoices to plants, approving bills for expenses attributable to the programs, maintaining a system for collection of receivables, and reporting periodically on the financial status of the programs to the NPCA Quality Assurance Committee.
- 2.1.7 Issue certificates or plaques to each plant that qualifies as an NPCA Certified Plant.
- 2.1.8 Issue certificates to each plant for products (s) that meet the requirements of the NPCA Product Listing.

2.2 NPCA Quality Assurance Committee

Duties of NPCA Quality Assurance Committee include but are not limited to:

- 2.2.1 Establish policies relating to the requirements of the programs.
- 2.2.2 Give direction to the administrators of the programs.
- 2.2.3 Give direction in the selection of plant inspection agency or agencies.

- 2.2.4 Oversee the programs content, including direction on plant inspections and administration of the programs.
- 2.2.5 Promote the programs to the NPCA members.
- 2.2.6 Publicize the programs to buyers of precast concrete products.
- 2.2.7 Oversee revisions of the NPCA Quality Control Manual for Precast Concrete Plants and other related publications.
- 2.2.8 Oversee revisions of the programs, including the grading schedule.
- 2.2.9 Serve as an Appeals Board (see Part 6).

2.3 Inspection Agency

The NPCA Quality Assurance Committee will select an inspection agency or agencies that have personnel who are trained, qualified and knowledgeable about the operations of precast concrete manufacturing plants and production of quality precast concrete products. They also must have experience in quality control operations and be able to audit plants with minimal advance notice.

Auditors shall have an engineering degree (preferably civil or structural engineering), unless otherwise approved by NPCA, and shall have attended NPCA auditor training and shall have been appropriately trained by NPCA and the agency and shall have gained experience necessary through shadowing other auditors in field activities to critically assess the manufacturing process and production of precast concrete. The auditor shall display knowledge, experience, integrity, ability and good professional judgment. The auditor shall be thoroughly familiar with the NPCA QC Manual and all other pertinent technical publications of NPCA, ACI, ASTM International, and other industry standards. The auditor shall have sufficient skill in dealing with other persons to earn their respect, and to deal with them courteously while maintaining the requisite professional distance. The third party agency shall promptly accede to any request by NPCA that an auditor be replaced in view of a lack of any of these qualities. All audits shall be performed under the supervision and reviewed by a Professional Engineer. NPCA Auditors will provide their official credentials upon meeting with the plant liaison on the day of the plant audit. All third party agency auditors shall abide by the NPCA confidentiality and conflict of interest agreement and shall conduct themselves in a professional and impartial manner.

Before performing any NPCA plant audits, the agency and its personnel must become familiar with both the NPCA Quality Control Manual for Precast Concrete Plants and the programs. The agency must also develop a quality assurance

program, which will ensure that all audits are made in a uniform manner and that a uniform grading system is used.

The agency will perform the audits as detailed in the applicable agency specific contract documents and Part 3 and Part 7.

The NPCA Quality Assurance Committee may select more than one audit agency, in which case all of the above items are applicable to each agency, including uniformity of inspections and grading, confidentiality, conflict of interest and impartiality.

Third party agency auditors shall not be eligible to perform plant audits during the program year without attending NPCA auditor training and / or as authorized by NPCA.

Third party agencies shall hold a current accreditation to ISO/IEC 17020.

2.4 Recording Keeping

The Administrators will maintain all pertinent records of the programs. These records include but are not limited to:

2.4.1 Pertinent correspondence

2.4.2 Meeting minutes of the NPCA Quality Assurance Committee

2.4.3 Program Contracts

2.4.4 Plant certificates

2.4.5 Completed audit reports, and grading schedules, and plant corrective action responses.

2.4.6 Standardized grading schedules

2.4.7 Correspondence dealing with appeals

2.4.8 Current list of certified plants and products.

2.5 Continuous Improvement

Satisfaction of continuous improvement requirements will be based solely on the plant providing objective evidence to the auditor that activities are in place and/or have taken place at the plant. NPCA plant auditors will be required to visit the NPCA Producer Portal and view plant documentation online prior to their inspection of the plant. This initial evaluation of plant records shall include those activities pointed at continuous improvement activities engaged by the plant.

In order for plants to be considered for continuous improvement points they must participate in two of the following:

- (1) The plant shall upload documents to the Certified Producer Portal and earn 1% to be added to the plant final score for completing the following items;
 - a. The plant shall update their plant profile sheet annually;
 - b. The plant shall download their renewal certificate annually;
 - c. The plant shall download their final inspection report and certificate annually (hard copies can be made available upon request);
 - d. At a minimum, the plant shall upload annual certification records for raw materials, annual calibration of equipment, current ACI certifications and current PQS certifications for quality personnel;
 - e. Plants producing stormwater and/or sanitary concrete pipe shall upload current annual absorption test data;
 - f. Plants producing round manhole products shall upload current annual absorption test data;
 - g. Plants producing septic tanks shall upload current annual watertightness test data for all models produced;
 - h. Plants producing grease interceptors shall upload current annual watertightness test data for all models produced.
- (2) The plant shall perform and generate final reports for semi-annual self-audits using the Self-Audit tool within the Producer Portal. The plant shall earn 1% to be added to the plant final score for completion of semi-annual self-audits;
- (3) The plant shall complete education requirements and uploads equivalent to 1 hour of education for each plant employee annually. The plant shall earn 1% to be added to the plant final score for completion of the following;
 - a. Plant Quality Personnel – certificate upload for NPCA PQS training beyond current minimum specified in section 1.1.3 of the NPCA QC Manual, PQS Level II QA/QC-Technical, PQS Level II-Production (including a current Master Precaster certification in year one followed by 4 hours of continuing industry-related education in year two). Industry related education uploaded information shall include learning objectives, course description and certificate of completion.
 - b. Non-Quality Plant Personnel – Any NPCA course offering applies. Industry-related education uploaded information shall include learning objectives, course description and certificate of completion.

The plant is eligible to earn up to an additional 6% added to the plant final score for continuous improvement efforts in the four categories of Section 1.1.4 of this manual. Satisfactory activity in these four categories shall be evaluated by active participation and objective evidence provided by the plant to the designated third-party auditor during the plants annual unannounced plant inspection.

Plants earning probationary status or failing it's annual inspection are not eligible for continuous improvement added values.

PART 3

Plant Audits

3.1 Scheduling

The Administrators will help coordinate initial audit between the plant and the agency, so that the audit is made at a mutually convenient time. Subsequent unannounced audits shall be released by NPCA to the agency each year and scheduled by the agency and be performed at least once per calendar year, or as directed by NPCA. Annual program fees shall be due on or before January 1st of each calendar year.

3.1.1 Plants must receive their annual audit within 16 calendar months of their previous audit or may be subject to decertification.

3.2 Plant Liaison Representative

Plant management will assign one person to serve as a liaison representative during the audit. The plant liaison representative will be available to assist in the audit by making quality control records, calibration records, drawings, etc., available for review by the auditor. The Plant Liaison will also be available to accompany the auditor throughout most of the operations in order to utilize the auditor's time most efficiently.

3.3 Duties of the Auditor and Agency Personnel

3.3.1 The auditor will arrive at the plant prepared to begin the inspection.

3.3.2 The auditor will not depend upon the plant for transportation to or from the plant nor for meals or lodging during the audit.

3.3.3 The auditor will abide by all safety regulations of the plant.

3.3.4 The auditor will neither impede nor delay any of the plant's operations.

3.3.5 The auditor may videotape parts of the audit or take photographs, but only if permitted to do so by plant management.

3.3.6 The auditor will observe and grade those items for which points are assigned on the grading schedule. Using the plants internet connection or a connection in the vicinity of the facility, the auditor will generate a preliminary report using the NPCAAuditor proprietary software program. Items that are not applicable will be so marked.

3.3.7 The auditor shall conduct a close-out interview. Plants shall receive a copy of their preliminary report and grading schedule and all observed deficiencies during the close-out interview. See section 7.2.7 for responsibilities of the plant.

- 3.3.8 At the conclusion of the close-out interview, the auditor and a plant representative present will sign and date the close-out interview documents, such as, but not limited to, the preliminary report and grading schedule and / or the close-out interview form provided by the auditor and these documents will become part of the permanent record of the inspection.
- 3.3.9 If for some reason the plant does not agree with the audit scoring or there are specific circumstances that cannot be agreed upon at the conclusion of the close-out interview; the plant representative should not sign the close-out form. This action will start the appeals process (see Section 6).
- 3.4.0 Auditors shall maintain the highest level of integrity and professionalism. Inspection agency employees and inspection personnel shall abide by the NPCA confidentiality and conflict of interest policies currently in force. Agency personnel shall exhibit impartiality during inspections proceedings and when representing the NPCA Plant Certification programs. Activities of inspection shall not be marketed in such a manner as to compromise the impartiality of the NPCA certification program.

PART 4

GRADING SCHEDULES

- 4.1 The grading schedules are shown in the section titled “Grading Schedule” in the NPCA Quality Control Manual for Precast Concrete Plants. It can be seen that the items listed specifically refer to sections of the NPCA Quality Control Manual for Precast Concrete Plants.
- 4.2 Sections to be graded have been assigned “points” (A) shown in the first column on the right. The auditor grades each section based on the percentage of compliance with the Quality Control Manual shown in the second column (B). Certain items may not be applicable (NA) to all plants during an inspection. Those items are not graded. For each graded item the number of points (A) is multiplied by the grade percentage (B). The sum of those values is obtained for each chapter. Because some items are not applicable, an adjustment is made.
- 4.3 The grade adjustment consists of multiplying the sum of $A \times (B/100)$ for each chapter by 100 and dividing by the total possible points that are applicable and/or observable. The final plant score represents the percentage of total points earned by the plant versus the total applicable and/or observable points.
- 4.4 Completed grade sheets are sent to the plant representative, and a copy is kept on file by the Administrator. No other copies are distributed unless the applicable plant provides consent or instruction to do so in writing to the program Administrators.
- 4.5 Critical sections of the manual are graded with the actual scoring percentage earned by the plant for each specific element and totaled. Plants scoring less than 75% in any critical section will be awarded zero ‘0’ points for that element. New plants scoring less than 75% in any critical section during their initial announced plant inspection will not be considered for certification. Existing plants scoring less than 75% in any critical section or an overall plant score of less than 80% but greater than or equal to 75% during their annual unannounced plant inspection will be subject to probationary status (See part 5.2.1 Probationary Status).

PART 5

GRADING, CERTIFICATION STATUS, and CORRECTIVE ACTIONS

5.1 Certified Status

- 5.1.1 A plant qualifies as a certified plant if it achieves a plant score of 75% or greater in each applicable Critical Requirement section of the pertinent grading schedule and achieves an overall score of 80% or greater.
- 5.1.2 A plant fails its audit if it achieves an overall score less than 75%.
- 5.1.3 A plant qualifies for NPCA product listing if it provides a complete and NPCA approved document submittal and passes it's initial or annual unannounced audit.
- 5.1.4 A plant is not eligible for product listing if it earns probationary status or fails it's annual unannounced audit.
- 5.1.5 Plants earning probationary status or failing it's annual unannounced audit will loose listing status and must reapply to the program.

5.2 Probationary Status

- 5.2.1 A plant that does not comply with the conditions set forth in section 5.4.1; Corrective Action response, achieves a score of less than 75% for any critical requirement or achieves an overall plant score greater than or equal to 75% and less than 80% is eligible to receive probationary certification status.
- 5.2.2 Probationary Certification status shall remain in effect until such time when the plant is re-audited and for a period not to exceed 90 calendar days from the previous audit and the conditions calling for probationary status no longer exist, as determined by the audit agency and/or NPCA or its agent. Plants failing to pay the applicable fee within 30 days of the invoice date and receive a re-audit of the plant within 90 days from the previous audit will not be considered for certification.
- 5.2.3 In no way will the plant listing on the NPCA Web site or anywhere else indicate that a plant has received probationary certification.
- 5.2.4 The plant must pass their unannounced re-audit and receive an overall score of 80% or greater and must score at least 75% on all Critical Requirements in order to be removed from probationary status.
- 5.2.5 Plants that fail their unannounced re-audit will be required to reapply to the program.

5.3 Provisional Status

5.3.1 The Provisional Certification period is effective when a plant that is currently certified in the program, fails an unannounced audit, and appeals the results of the audit. This period is intended to allow sufficient time for a plant to appeal the results of the failed audit, while maintaining certified status. The Provisional Certification period is as follows:

5.3.1.1 A plant that appeals the results of the audit and the appeal is approved, the Provisional Certification period ends on the date of the approved appeal. Thereafter, the plant resumes normal certified status.

5.3.1.2 For plants that appeal the results of the audit and the appeal is denied, the Provisional Certification period ends on the date of the denied appeal and the plant is no longer certified. To re-enter the certification program, the plant must reapply, pay certification fees and successfully pass its unannounced audit.

5.3.1.3 Plants that do not appeal the results of a failed audit are not eligible for Provisional Certification. See section 6.2 for appeal deadline.

5.4 Corrective Actions

5.4.1 All plants passing their audit (regardless of score) must respond in writing indicating corrective action taken to all deficiencies noted in their report. All plants failing to submit a written response with documented evidence within 45 days of the plant audit will receive probationary status and be subject to the conditions set forth in section 5.2.1; Probationary Status.

Documented evidence shall be supplied (photographs, completed inspection forms, test results, copies of material certifications) to illustrate compliance to requirements and of the corrective action taken to both NPCA and the agency.

PART 6

APPEAL PROCEDURE

6.1 If plant management disagrees with the grade resulting from a plant audit, the approval of a product submittal or decision on product listing, management may file an appeal for review by the NPCA Quality Assurance Review Subcommittee, or their designees. See section 5.3 for information regarding Provisional Plant Certification during the appeals process. Provisional Plant Certification does not pertain to NPCA Product Listing.

6.2 The complete appeal shall be in the form of a letter or email addressed and sent to the program Administrator. A plant must appeal an audit within 45 calendar days of the plant audit. A copy of the Preliminary or Final Report grading schedule shall accompany the letter or email. Individual grades on specific sections with which management disagrees shall be circled and all supporting documentation (photographs, completed inspection forms, test results, copies of material and certification to illustrate compliance to requirements) shall be provided along with reasons why management believes each circled grade should be changed. If the plant fails to provide a written appeal and all relevant documentation the appeal will be denied.

Plants wishing to file a formal appeal of their audit must do so within 45 calendar days of the plant audit. The complete appeal shall be received in the form of a letter or an email along with all supporting documentation addressed and sent to the program Administrator. Supporting documentation shall include items such as, but not limited to, a copy of the preliminary or final report grading schedule, photographs, completed inspection form, test results, and copies of material to illustrate compliance to requirements along with corrective action responses to all deficiencies noted in the inspection report. The plant representative shall also supply reasons they believe a scoring appeal is warranted.

6.3 If necessary the Review Subcommittee shall request a response from the inspection agency. The agency will respond briefly in writing to the Administrator within 21 calendar days of receipt of notice of appeal by the Administrator.

6.3.1 If the agency agrees with the appeal and agrees that the grade should be changed as requested in the appeal, the agency will prepare a revised report and grading schedule.

- 6.3.2 If the inspection agency disagrees with the appeal and believes that the grades originally assigned are appropriate and the plant wishes to have the appeal heard by the Quality Assurance Review Subcommittee (which acts as the appeals board), the chairperson (or designated program administrator) of the NPCA Quality Assurance Committee will poll the Review Subcommittee members to determine if they (a) agree with the appeal and disagree with the agency's response, or (b) disagree with the appeal and agree with the agency's response. The chairperson (or designated program administrator) shall poll the members to determine if a hearing of the appeal is needed and if so, to establish a date for the hearing. Subcommittee members who have a conflict of interest with regard to the plant in question must remove themselves from the polling.
- 6.4 The Director of Quality Assurance Programs will review all product listing related situations and notify the NPCA Quality Assurance Review Subcommittee of any action needed.
- 6.5 Hearings for appeals will usually be scheduled to coincide with the regularly scheduled monthly meetings of the NPCA Quality Assurance Review Subcommittee, but hearings may be held at other times which are mutually convenient for the Review Subcommittee, management of the plant which filed the appeal, and the inspection agency and may consist of a conference call.
- 6.6 Hearings for appeals will be closed meetings with only the Quality Assurance Review Subcommittee, the Administrators, management of the appealing plant, and if required the agency representative. The management of the plant which filed the appeal will first present its case orally and the committee may ask questions of the speaker. The agency representative will then orally present its case followed by answering questions raised by the committee. Management of the appealing plant then will make its closing statement and that will be followed by the closing statement of the agency representative. Representatives of the appealing plant and the agency will then be excused so that the Subcommittee can deliberate in executive session.
- 6.7 If a member of the Quality Assurance Review Subcommittee is a representative of the appealing plant, or it is determined that they have a conflict of interest, that Subcommittee member shall excuse themselves from the deliberations in executive session.
- 6.8 Decisions of the Quality Assurance Review Subcommittee will be sent to both the plant management and the agency within ten calendar days of the hearing. The Quality Assurance Review Subcommittee's decision(s) will be final and no further appeals will be considered.

PART 7

7.1 Applicable Plant

The NPCA Plant Certification Program Contracts and Product Listing Application apply only to the plant described in the Plant Profile Information supplied by the plant. However, in cases where a plant operates two production facilities at separate physical locations and they are within a 20-mile driving distance of each other, the plant may elect to include both of these production operations under one contract and be inspected during the same audit visit. A single report will be issued by the agency for both production locations. This means that the success of either plant is dependent on the other plant – if one fails, they both fail. In addition, in such instances, it may be necessary for the program fee to be increased, because the production operations are too large and/or too complex to adequately audit during a normal-length (one-day) period and an additional audit day shall be required. Such instances will be judged on a case-by-case basis jointly by the agency and NPCA. In all other cases, each production operation must use separate NPCA contracts for each production operation, if so desired. Multiple physical plant location option does not apply to NPCA Product Listing.

7.2 Audits and Certification

- 7.2.1 Audits will be conducted by an approved, accredited, and independent audit agency or agencies appointed by NPCA. NPCA retains sole authority in the appointment of one or more audit agencies. Certification of the plant shall be established on the basis of the plant's satisfactory performance during these audits, as described in the Program and the QC Manual, which are incorporated herein by reference.
- 7.2.2 Scheduling of first time, announced (initial) and subsequent unannounced annual audit shall be at the sole discretion of the audit agency once released by NPCA. However, the audit agency shall contact the plant in an effort to determine a date for the first time, announced audit that is mutually agreeable.
- 7.2.3 The plant must agree to schedule the first-time, announced audit within three-months (90 days) of signing the program Contract; otherwise the plant agrees to forfeit the entire certification fee.
- 7.2.4 Plants that apply to the program, pay applicable fees, receive their initial inspection after September 30 will be granted certification through December 31st of the following calendar year (15 months). Certification fees beyond year one are due on or before December 31st of each year.

- 7.2.5 First time (initial) plant audits will be announced to the plant in advance. Advance notice will typically be approximately two (2) to four (4) weeks. For the plant's initial audit, the plant shall have records required by the program for a minimum of thirty (30) calendar days of production immediately prior to the audit date.
- 7.2.6 Subsequent annual audits will be unannounced.
- 7.2.7 Inspections, grading and certification shall be conducted as described in the program.
- 7.2.8 The plant agrees to cooperate fully with the audit agency and its employees. The plant shall allow the auditor access to the facilities internet connection and printer for generating the close-out interview documents.
- 7.2.8.1 The plant agrees to cooperate fully in the situation that the audit agency is being audited by NPCA while performing a plant audit.
- 7.2.8.2 The plant agrees to cooperate fully in the situation that the audit agency auditor is being audited by NPCA who is being audited by the ANSI auditor when performing a plant audit.
- 7.2.8.3 The plant agrees to comply fully with the program contract document.
- 7.2.9 In Non-English speaking locations, the plant agrees to provide an English-speaking liaison to the auditor to interpret communications between the auditor and plant representatives.
- 7.2.10 Immediately following the audit, the auditor will hold a closeout interview and be available for discussion and questions about the inspection with plant representative and/or management.
- 7.2.11 The audit agency will audit the plant for the sole purpose of assessing the plant's compliance with the standards outlined in the most current edition of the NPCA QC Manual, unless otherwise directed by NPCA. NPCA reserves the right, at its sole discretion, to periodically update and modify the QC Manual.
- 7.2.12 No audit or observation will be made of safety, environmental or other conditions, and NPCA and the audit agency disclaims responsibility to the plant and any third party for such conditions.
- 7.2.13 The programs do not certify products, or the company as a whole. The programs instead confirm the capability of the audited plant, in which products are produced to meet the minimum requirements of the Program. This confirmation includes, but is not limited to; the plant's manufacturing processes, production procedures and quality control operations.

- 7.2.14 Active production operations must be observed by a representative of the audit agency during all inspections. When awaiting an unannounced audit, the plant shall provide accurate production schedule information to NPCA. This information is then used by the inspection agency to schedule unannounced inspections appropriately.
- 7.2.14.1 The plant shall notify NPCA in writing of dates when production will not take place as far in advance as possible, but not later than 14 calendar days prior to any date in which production operations will not take place during normal production days. For the purposes of the program Contract, normal production days are defined as Monday through Friday.
- 7.2.14.2 Plants will be charged for the audit agency's time and expenses if they fail to notify NPCA in writing of a date in which production operations did not occur AND the audit agency attempts to perform an unannounced audit at the plant on that date, but is unable to do so because of a lack of observable production operations. This fee is payable and subject to the provisions set forth in the applicable Program Fee Schedule.
- 7.2.14.3 Instances of unforeseen production stoppage caused by conditions beyond the plant's control (such as inclement weather, unexpected equipment breakdown, third-party raw material delivery delays, etc.) shall NOT be cause for this extra charge. However, the plant shall practice due diligence and notify NPCA in writing when such unforeseen production stoppages occur. If it is deemed that the plant did not put forth a good faith effort to notify NPCA, the plant will be charged for the audit agency's time and expenses associated with the attempted audit.
- 7.2.14.4 Plants refusing an unannounced audit for reasons other than those stated in Subsection 7.2.1314.3 above constitute grounds for the plant to be decertified.
- 7.2.14.5 The NPCA Quality Assurance Review Subcommittee will resolve any disputes that may arise regarding interpretation of this section of the contract. The decision of the NPCA Quality Assurance Review Subcommittee will be final.

- 7.2.15 In the process of promoting the NPCA Plant Certification and/or Product Listing Programs to various specifying agencies, from time to time, representatives from these agencies may request to observe an actual inspection. The plant agrees to cooperate fully in good faith with this process and, in case of such a request from a specifying agency representative, the plant agrees to allow the representative to observe an audit at their facility, whether or not the audit is announced or unannounced.
- 7.2.16 The plant must notify NPCA, in writing, of any materially changed condition, as defined in the following, within 30 calendar days of the change. Failure to do so may result in decertification.

7.2.16.1 Change in plant ownership.

7.2.16.2 Change in the type or capability of operations, equipment or facilities, or the physical location of the facility in relation to the requirements of the program. If the reported change is judged jointly by the NPCA Quality Assurance Committee, NPCA and the Audit Agency to substantially affect or influence the plant's capabilities of adhering to the requirements of the program, the plant shall receive an additional, unannounced audit. The cost of such an audit shall be borne by the plant in the amount of the standard program fee.

PART 8

8.0 Additional Random Unannounced Audits

- 8.0.1 The frequency of unannounced additional random unannounced audits shall be determined by the NPCA Quality Assurance Committee, and/or NPCA, at its sole discretion.
- 8.0.2 If NPCA receives written evidence from a credible authority that asserts that a certified plant is not in substantial compliance with the requirements of the applicable program, the NPCA Quality Assurance Committee, NPCA and the Inspection Agency, jointly and at their sole discretion, shall determine if there is sufficient cause to conduct an unannounced re-audit at the plant. The cost of such an audit shall be borne by the plant.
- 8.0.3 Should a plant fail an audit, the plant must follow the procedures set forth in Section 5.3.

8.1 Confidentiality

- 8.1.1 Except as required by legal order or otherwise required by law, neither NPCA nor the audit agency nor any of their employees shall reveal any specific data or grading with respect to the plant audited, other than to the plant's authorized representative, except with the plant's written consent.
- 8.1.2 Specifying agencies may, on occasion, request copies of certification reports and/or grading information for review. NPCA will not provide this information, unless specifically directed to do so in writing from the plant. An individual plant may elect, at its own discretion, to provide this information directly to a specifying agency to satisfy such a request.

8.2 Plant Certification

The NPCA Plant Certification is envisioned to be the foremost management tool for precast concrete manufacturing. The certification process furnishes a framework for management decisions in making changes in equipment and procedures to create a quality manufacturing environment. Upon Certification:

- 8.2.1 The plant shall receive a Certification Plaque, supplied by NPCA. For plants that choose to certify two production locations under the provisions of the program Contract, each location shall receive a separate plaque, noting the location or each.
- 8.2.2 NPCA will grant the plant the right to use, in conformance with the program guidelines and contract, the appropriate Certification seal, emblem, logo, etc. (Symbol) for use on stationery and for advertising purposes for as long as the plant's Certification is in effect and provided such use is only in reference to the plant covered by the program contract, and not the company as a whole nor any other non-certified branch locations. Additionally, the plant may only place NPCA Plant Certification Symbol or any other reference to the program on products produced at the plant location(s) covered under the NPCA Plant Certification Program Contract.
- 8.2.3 Certified plants are registered with NPCA and are added to the NPCA published list of certified precast concrete plants. This listing is included in the NPCA Annual Membership Directory and on the NPCA Web site. In cases where two production locations are covered by this contract, both shall be listed separately.
- 8.2.4 It is understood that in issuing a certification plaque and Symbol, and authorizing its use, NPCA does not approve, endorse or guarantee any inspection, product, system or construction, or in any way make any expressed or implied warranties in connection with any inspection, product, system or construction.
- 8.2.5 The certification plaque and Symbol remain the property of NPCA and must be surrendered by the plant immediately in the event of expiration, decertification, termination of this contract, or withdrawal from the program, and any use of NPCA Plant Certification Program literature, advertising, or stationery or any other materials referencing the program must immediately cease.
- 8.2.6 In the event that NPCA becomes aware of evidence that the Certification seal, emblem, logo, or other symbol of or reference to certification is being used by an unauthorized person or organization, NPCA shall ask its General Counsel to assess whether the evidence is sufficient to issue a letter instructing the misappropriating person to cease and desist from the misappropriation. If the evidence is deemed sufficient, the General Counsel shall issue a letter to the misappropriating person or organization based upon whether the misappropriating person is an applicant or member of the Certification Program, or not involved in the program.

If the evidence is not deemed sufficient for a "cease and desist" letter, the President may issue a letter to the misappropriating person expressing

NPCA's concern and asking for an assurance that symbols and references to certification are not being misused.

If the misappropriating person continues in the misconduct, the President shall take such action as is deemed necessary to protect the integrity of the Certification Program, including without limitation further oral and written contacts with the misappropriating person, suspension of membership in NPCA, and appropriate remedies through legal action, including litigation to obtain a cease and desist order and/or monetary damages. Further, NPCA shall seek the court's order that the Plant shall reimburse NPCA for all expenses incurred in obtaining judicial relief.

8.3 Product Listing

- 8.3.1 Plants participating in the NPCA Product Listing Program are required to pass a watertightness test on a tank model chosen at random by the inspector on the day of the plant's inspection each program year to maintain listing.
- 8.3.2 Upon successful completion of their inspection and approval of submittal, the plant shall receive a Product Listing Certificate, supplied by NPCA.
- 8.3.3 NPCA will grant the plant the right to use, in conformance with the program guidelines and contract, the appropriate Product Listing seal, emblem, logo, or stencil (Symbol) for product marking purposes for as long as the plant's Certification is in effect and provided such use is only in reference to the plant covered by the program contract, and not the company as a whole nor any other non-certified branch location. Additionally, the plant may only place the NPCA Product Listing Symbol or any other reference to the program on listed products produced at the plant location (s) covered under the NPCA Product Listing Program Application.
- 8.3.4 Listed products are registered with NPCA and are added to the NPCA published list of certified precast concrete plants. This listing is included in the NPCA Annual Membership Directory and on the NPCA website.
- 8.3.5 It is understood that in issuing a product listing certificate and Symbol, and authorizing its use, NPCA does not approve, endorse, or guarantee any inspections, product, system, or construction, or in any way make any expressed or implied warranties in connection with any inspection, product, system, or construction.
- 8.3.6 The product listing certificate and Symbol remain the property of NPCA and must be surrendered by the plant immediately in the event of expiration, probationary status, failure, decertification, termination of this contract, or withdraw from the program and any use of NPCA Product Listing Program literature, advertising, or stationery or any other materials referencing the program must immediately cease.
- 8.3.7 In the event that NPCA becomes aware of evidence that the Product Listing seal, emblem, logo, stencil or other Symbol or reference to certification is

being used by an unauthorized person or organization, NPCA shall ask its General Counsel to assess whether the evidence is sufficient to issue a letter instructing the misappropriating person or organization to cease and desist from the misappropriation. If the evidence is deemed sufficient, the General Counsel shall issue a letter to the misappropriating person or organization.

If evidence is deemed not sufficient for a “cease and desist” letter, the President may issue a letter to the misappropriating person or organization expressing NPCA’s concern and asking for an assurance that Symbols and references to certification are not being misused.

If the misappropriating person or organization continues the misconduct, the President shall take such action as is deemed necessary to protect the integrity of the Product Listing Program, including without limitation further oral and written contacts with the misappropriating person or organization, suspension of membership in NPCA, and appropriate remedies through legal action, including litigation to obtain a cease and desist order and/or monetary damages. Further NPCA shall seek the court’s order that the person or organization shall reimburse NPCA for all expenses incurred in obtaining judicial relief.

8.4 Renewal and Expiration

8.4.1 The plant’s certification status shall be effective starting on the date of the initial audit, pending successful performance during the initial audit and subsequent re-audit, as detailed in the final audit report prepared by the audit agency. For NPCA Product Listing status shall be effective starting on the date of the passed plant audit and approval of the submittal package.

8.4.2 Upon renewal of NPCA certification each year, the plant gives NPCA permission to send electronic copies of plant inspection documents (reports, corrective actions to all deficiencies, and addendums) to a Department of Transportation (DOT) if so required by the DOT. NPCA will notify the plant of any request.

8.4.3 If the plant has not submitted payment of the program fees and any other paperwork required by the applicable program by January 1st each year, the plant’s certification shall automatically expire.

8.4.4 If the plant that has been decertified for any reason in the past, the plant shall agree to the following:

8.4.4.1 If the plant is decertified the plant is responsible for all applicable fees required to reenter the program as a new plant to the program. Additionally, plants that have been decertified will have their anniversary dates reset to the date of when they reentered the program.

8.4.4.2 Payment of all prior financial obligations must be made prior to renewal of this agreement or any other agreement regarding NPCA Plant Certification.

8.4.4.3 If a plant is decertified, all product listings are terminated.

8.5 Violation of Contract

The plant agrees to abide by the terms of this contract. The plant understands that NPCA reserves the right to change the terms and conditions governing certification, including the NPCA Plant Certification Program Contract, the NPCA Product Listing Program Contract, the requirements set forth in the QC Manual, and use of Symbols, from time to time, and the plant shall abide by such changed provisions upon receipt of notice thereof, or otherwise withdraw from the program by surrendering its plaque and foregoing use of the certification Symbol. Violation of this contract, or any part thereof, including, without limitation, any misrepresentation in the NPCA Plant Certification Program Contract, the NPCA Product Listing Program Contract or elsewhere by the plant or misuse of the Symbol, constitutes grounds for the plant to be decertified. In the event that the plant is notified in writing by NPCA of such decertification, the plant shall immediately surrender its plaque and cease using the certification Symbol or facsimile thereof in any way. NPCA may obtain, if necessary, specific enforcement of plant's obligations described in the applicable program contract by seeking the injunction of any court having jurisdiction.

8.6 Hazardous Materials

If NPCA or its audit agency encounters, or reasonably suspects that it has encountered, hazardous materials in a plant under audit, NPCA or its agency shall cease activity at the plant and promptly notify the plant's management. The plant shall initiate action, where appropriate, to identify and investigate the nature and extent of hazardous materials in the plant and to abate and/or remove the same as may be required by federal, state or local statute, ordinance, code, rule, or regulation now existing or hereinafter enacted or amended. The services to be provided by NPCA and its audit agency do not include identification of hazardous materials, and NPCA and its audit agency have no duty to identify or attempt to identify the same within the area of the plant. NPCA and /or the audit agency representative need not re-enter the plant until they, in their sole discretion, are satisfied that hazardous materials pose no problem to them.

NEW PLANT – Certification Process Logic

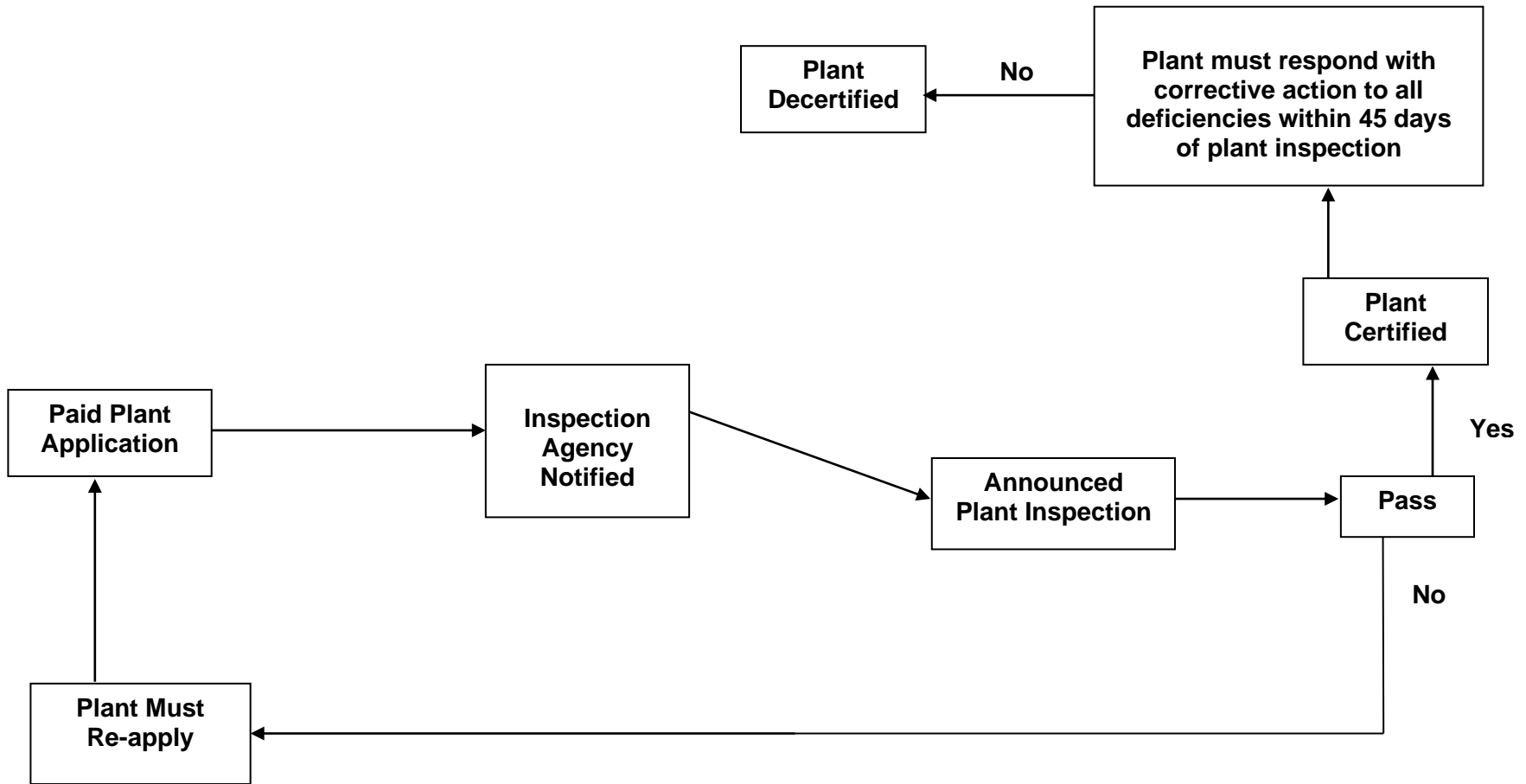

EXISTING CERTIFIED PLANT – Process Logic

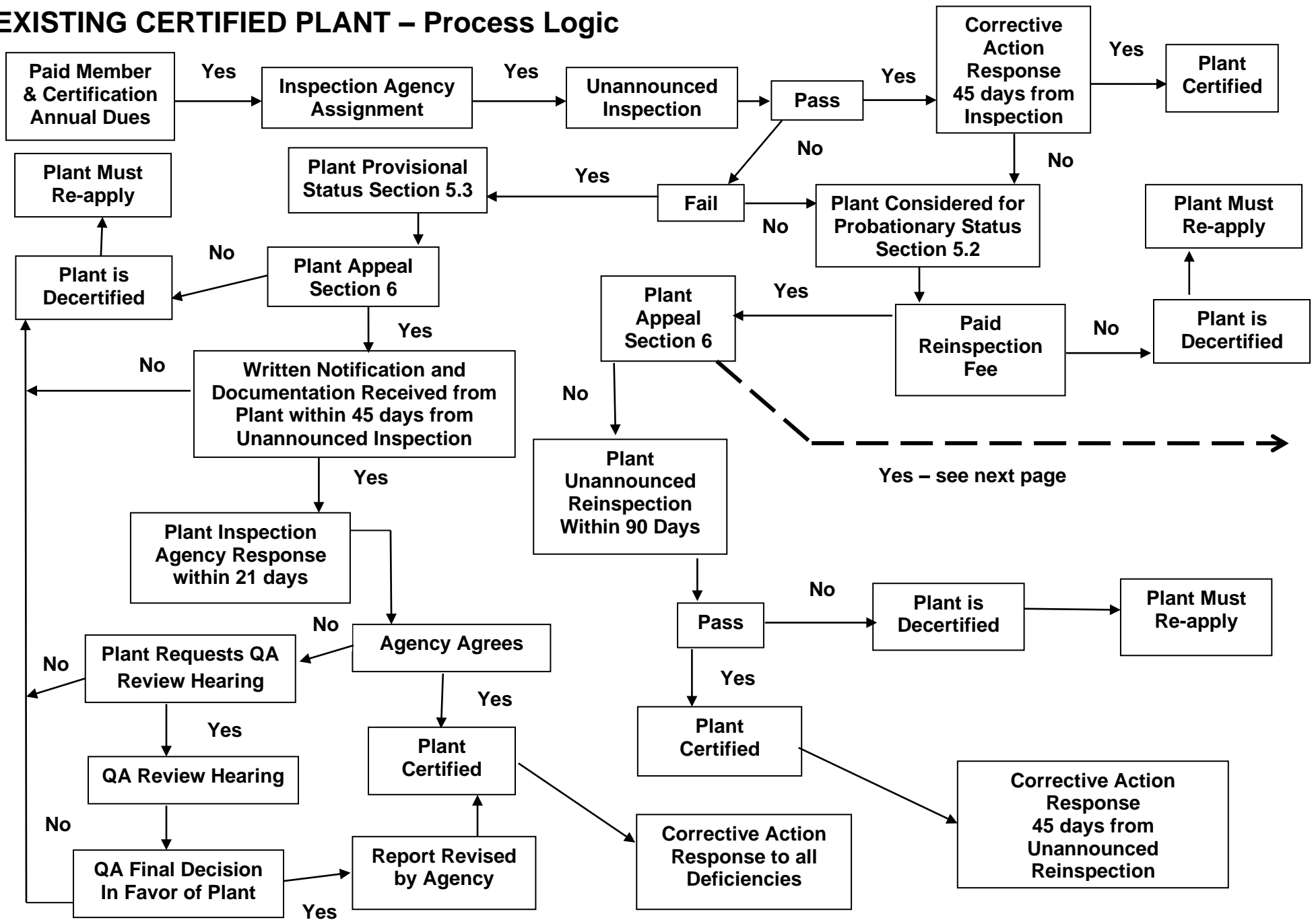

EXISTING CERTIFIED PLANT – Process Logic

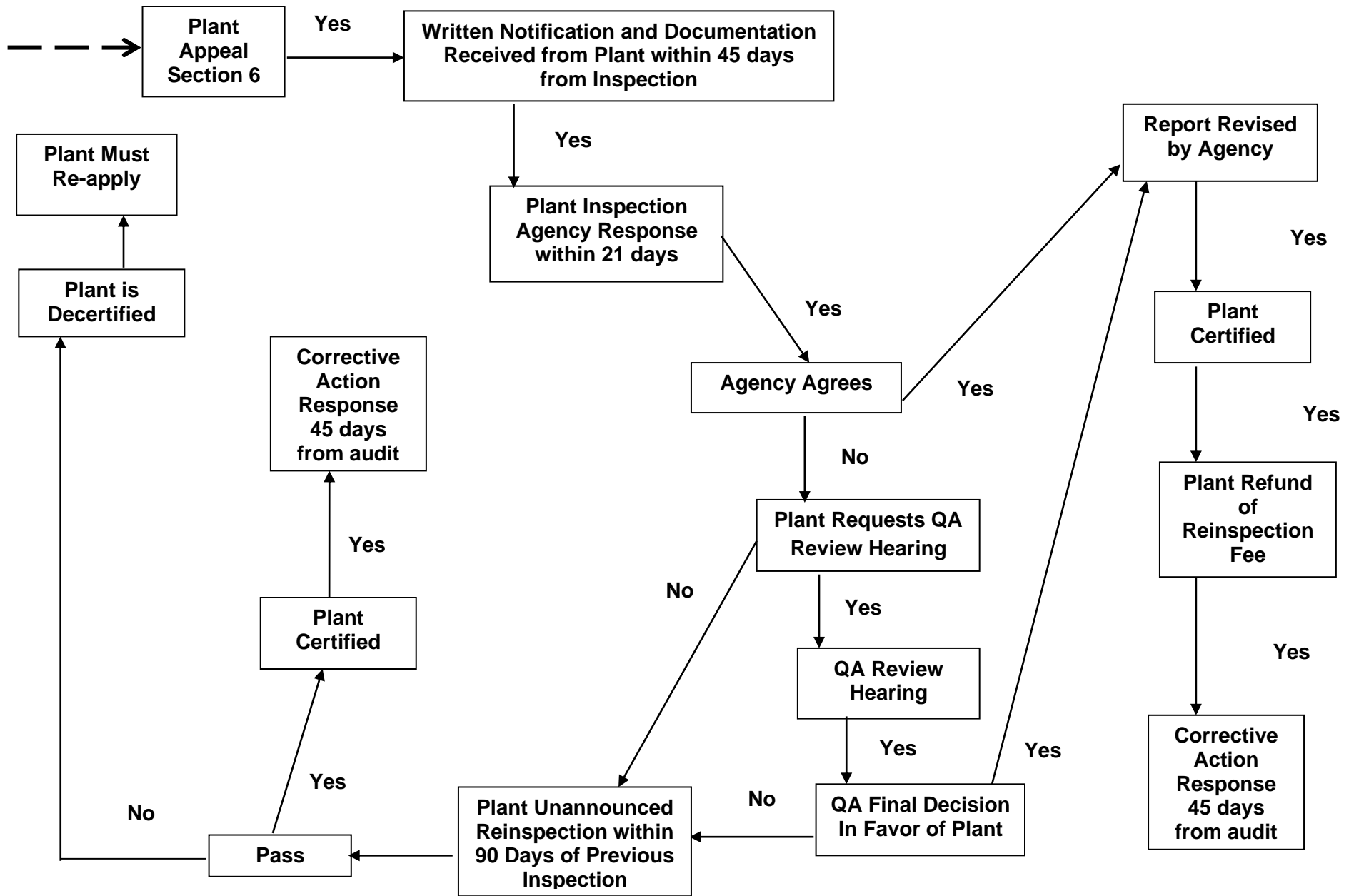

NPCA PRECAST PLANT CERTIFICATION PROGRAM GRADING SCHEDULE

Plant: _____ Location: _____

Date: _____ Inspector: _____

CHAPTER 1 GENERAL		Points (A)	Grade % (B)	(A x B) / 100	(A x B) Adjusted
1.1	Plant Quality Control Procedures and Management Policies				
	1.1.3 PQS & ACI Training Elements	6			
	1.1.1 Plant Mgmt. & Personnel	3			
	1.1.2 Plant-Specific QC Manual				
	1.1.5 Plant Requirements				
1.2	Plant Safety				
	1.2.1 Safety Program	1			
1.3	Drawings & Mock-Ups				
	1.3.1 Drawings	3			
	1.3.2 Mock-Ups				
Total Chapter 1		13			
CHAPTER 2 MATERIALS					
2.1	Concrete				
	2.1.1 Cement	3			
	2.1.2 Aggregates				
	2.1.3 Lightweight Aggregate				
	2.1.4 Mixing Water				
	2.1.5 Chemical Admixtures				
	2.1.6 Supplementary Cementitious Materials				
2.2	Reinforcement				
	2.2.1 Reinforcing Bars	3			
	2.2.2 Reinforcing Wire				
	2.2.3 Bar Mats and Welded-Wire Reinforcement				
	2.2.4 Zinc or Epoxy-Coated Reinforcement				
2.3	Miscellaneous Materials				
	2.3.1 Lifting Devices and Lifting Apparatus	2			
	2.3.2 Embedded Steel Shapes and Plates				
	2.3.3 Headed Studs and Deformed Anchor Studs				
	2.3.4 Manufacturing Accessories				
	2.3.5 Fiber Reinforcement				
	2.3.6 Joint Sealants and Connectors				
Total Chapter 2		8			

NPCA PRECAST PLANT CERTIFICATION PROGRAM GRADING SCHEDULE

CHAPTER 3 CONCRETE		Points (A)	Grade % (B)	(A x B) / 100	(A x B) Adjusted
3.1	Concrete Mixes				
	3.1.1 Mix Proportions	5			
	3.1.2 Water-Cementitious Materials Ratio				
	3.1.3 Air Content				
	3.1.4 Compressive Strength				
	3.1.5 Admixtures				
3.2	Batching and Mixing				
	3.2.1 Requirements for Batching and Mixing Plants	10			
	3.2.2 Storage of Cement and Supplementary Cementitious Materials				
	3.2.3 Handling and Storage of Aggregates				
	3.2.4 Batching Equipment				
	3.2.5 Discharge of Materials into Mixers				
	3.2.6 Mixers				
	3.2.7 Mixing				
	3.2.8 Ready-Mixed Concrete				
Total Chapter 3		15			
CHAPTER 4 PRODUCTION PRACTICES					
4.1	General				
	4.1.1 Plant Layout	10			
	4.1.2 Housekeeping				
	4.1.3 Forms and Forming Equipment				
	4.1.4 Handling Equipment				
	4.1.5 Machine-Made and/or Dry-Cast Products				
	4.1.6 Architectural Precast Concrete	10			
	4.1.6.1 Surface Finishes				
4.2	Fabrication of Reinforcement and Blockouts				
	4.2.1 Fabrication of Reinforcement CRITICAL SECTION	4	(a)		
	4.2.2 Welding of Reinforcing Steel	8			
	4.2.3 Welding of Steel Assemblies				
	4.2.4 Fabrication and Positioning of Blockouts				

NPCA PRECAST PLANT CERTIFICATION PROGRAM GRADING SCHEDULE

		Points (A)	Grade % (B)	(A x B) / 100	(A x B) Adjusted
4.3	Pre-Pour Operations				
	4.3.3 Positioning of Reinforcement CRITICAL SECTION	10	(a)		
	4.3.1 Cleaning of Forms	8			
	4.3.2 Application of Form Release Agent				
	4.3.4 Positioning of Misc. Embedded Items				
4.4	Casting Concrete				
	4.4.1 Transporting Concrete	8			
	4.4.2 Depositing Concrete into Forms				
	4.4.3 Consolidating Concrete				
	4.4.4 Finishing Unformed Surfaces				
	4.4.5 Secondary Pours				
	4.4.6 Hot Weather Precautions				
	4.4.7 Cold Weather Precautions				
4.5	Curing Concrete				
	4.5.1 General	4			
	4.5.2 Curing by Moisture Retention				
	4.5.3 Curing with Heat and Moisture				
4.6	Stripping Products from Forms				
	4.6.1 Minimum Strength Requirement	5			
	4.6.2 Product Damage During Stripping				
	4.6.3 Formed Surfaces				
	4.6.4 Post-Pour Inspection				
4.7	Repairing Concrete				
	4.7.1 Repairing Minor Defects	4			
	4.7.2 Repairing Major Defects				
	4.7.3 Inspection of Repairs				

NPCA PRECAST PLANT CERTIFICATION PROGRAM GRADING SCHEDULE

		Points (A)	Grade % (B)	(A x B) / 100	(A x B) Adjusted
4.8	Marking, Storage, and Shipment of Products				
	4.8.1 Product Marking	5			
	4.8.2 Storage Areas				
	4.8.3 Storage of Products				
	4.8.4 Shipment of Products				
	4.8.5 Final Inspection				
Total Chapter 4		76			

CHAPTER 5 QUALITY CONTROL OPERATIONS					
5.1	Summary of Required Records				
	5.1.1 Raw Material Test Records	9			
	5.1.2 Work Orders and Product Drawings				
	5.1.3 Equipment Calibration Records				
	5.1.4 Aggregate and Concrete Test Records				
	5.1.5 Concrete Batching Reports				
	5.1.6 General Plant and Product Inspection Records				
5.2	Aggregate Testing				
	5.2.1 Aggregate Gradation	3			
	5.2.2 Moisture Content				
5.3	Concrete Testing CRITICAL SECTION				
	5.3.1 Slump, Slump Flow, and VSI	9	(a)		
	5.3.2 Temperature				
	5.3.3 Density (Unit Weight)				
	5.3.4 Air Content				
	5.3.5 Compressive Strength				
	5.3.6 Plant Requirements				
Total Chapter 5		21			

NPCA PRECAST PLANT CERTIFICATION PROGRAM GRADING SCHEDULE

CHAPTER 6 SPECIAL REQUIREMENTS FOR SPECIFIC PRODUCTS		Points (A)	Grade % (B)	(A x B) / 100	(A x B) Adjusted
6.1	Products Manufactured According to ASTM International and Other Industry Standards				
	6.1.1 Product Manufacture	3			
	6.1.2 Proof of Conformance				
6.2	Concrete Pipe Requirements				
	6.2.1 Stormwater Concrete Pipe				
	6.2.1.1 Reinforcing Steel Inspection CRITICAL SECTION	10	(a)		
	6.2.1.2 Three-Edge Bearing Testing CRITICAL SECTION	10	(a)		
	6.2.1.3 Absorption Testing CRITICAL SECTION	1	(a)		
	6.2.1.4 Dimensional Checks	6			
	6.2.1.5 Joint Design and Testing				
	6.2.1.6 Watertightness Hydrostatic				
	6.2.1.7 Watertightness Vacuum				
	6.2.1.8 Gasket Quality Control				
	6.2.2 Sanitary Concrete Pipe				
	6.2.2.1 Reinforcing Steel Inspection CRITICAL SECTION	10	(a)		
	6.2.2.2 Three-Edge Bearing Testing CRITICAL SECTION	10	(a)		
	6.2.2.3 Absorption Testing CRITICAL SECTION	1	(a)		
	6.2.2.4 Dimensional Checks	6			
	6.2.2.5 Joint Design and Testing				
	6.2.2.6 Watertightness Hydrostatic				
	6.2.2.7 Watertightness Requirements				
	6.2.2.8 Off-Center Joint Proof of Design Testing				
	6.2.2.9 Joint Shear Proof of Design Testing				
	6.2.2.10 Confined Gasket Proof of				
	6.2.2.11 Gasket Quality Control				

NPCA PRECAST PLANT CERTIFICATION PROGRAM GRADING SCHEDULE

		Points (A)	Grade % (B)	(A x B) / 100	(A x B) Adjusted
6.3	Round Manhole Requirements				
	6.3.1 Reinforcing Steel Inspection CRITICAL SECTION	10	(a)		
	6.3.3.1 Absorption Testing CRITICAL SECTION	1	(a)		
	6.3.2 Flat Slab Tops	5			
	6.3.3 Base, Riser and Cone Sections				
	6.3.4 Joint Design				
	6.3.5 Gasket Quality Control				
6.4	Box Culvert Requirements				
	6.4.1 Absorption Testing	1			
	6.4.2 Joint Design	5			
	6.4.3 Pre-Pour Inspections CRITICAL SECTION	10	(a)		
	6.4.4 Dimensional Checks CRITICAL SECTION	10	(a)		
6.5	Septic Tank Requirements				
	6.5.1 Structural Proof-of-Design	3			
	6.5.2 Watertightness Testing CRITICAL SECTION	10	(a)		
6.6	Grease Interceptor Requirements				
	6.6.1 Structural Proof-of-Design	3			
	6.6.2 Watertightness Testing CRITICAL SECTION	10	(a)		
	Total Chapter 6	124125			
Score from All Chapters					
1.1.4 Continuous Improvement Points					
Deductions for repeat deficiencies from previous inspection					
PLANT SCORE ^(b)					

^(a) Critical Requirement Section – This and all other applicable Critical Requirement Sections require a minimum passing grade of 75% in order to achieve normal certification status. Plants scoring less than 75% in one or more Critical Requirement Section shall receive probationary certification, must document and take corrective action within 30 days to improve plant operations, and may be required to complete an additional inspection within 90 days (at the plant’s expense) and must receive a score equal to or greater than 75%.

^(b) The Plant Score is equal to the percentage of total points earned by the plant divided by the total applicable and/or observable points. Plants must score 80% or higher in order to achieve normal certification status. Plants receiving a score above 75% and less than 80% shall receive probationary certification, must document and take corrective action within 30 days to improve plant operations, and may be required to complete an additional inspection within 90 days (at the plant’s expense) and must receive a score equal to or greater than 80%.



General Grading Philosophy

- If the plant is meeting all the requirements at the proper frequencies, the records are well organized and easily retrieved, and no problems with that item are noted, they should be given a score of 100 percent for that item.
- Double deductions for major infractions / deficiencies
- The lowest possible score for each section is zero

- The following standard deductions should be subtracted from a grade of 100% for the particular section, assuming that no other deficiencies are noted.

Section	Subsection	General Comments & Grading	Common Deficiencies	Deduction(s)
4.2 Fabrication of Reinforcement and Blockouts	4.2.1 Fabrication of Reinforcement	All reinforcing steel shall be fabricated to a detailed reinforcing steel plan document in conformance with the precast concrete product tolerances and / or tolerances provided in the project specifications or plans. If no dimensional tolerances have been established, or reference given, the plant shall specifically state on the plan documents or in the plant specific quality control manual, the dimensional tolerance scheme that will govern for the product; such as but not limited to the Concrete Reinforcing Steel Institute (CRSI) publication, "Placing Reinforcing Bars," and / or the Reinforcing Steel Institute of Canada / Institut D'acier du Canada (RSIC / IAAC) publication, "Reinforcing Steel, Manual of Standard Practice". Reinforcing steel cages shall be inspected for conformance to approved design requirements and documented with the pre-pour inspection. The inspection requirements are detailed in Section 4.3.3 Positioning of Reinforcement.	Detailed reinforcing steel plan documents are not available for precast products produced Some detailed reinforcing steel plan documents do exist but not for all precast products produced {if less than 75% of products 100% deduction} Detailed reinforcing steel plan documents do not specify applicable tolerance information Required information is missing from the plan documents; deduct 20% per element missing	100% Estimate % 10% Estimate %
4.3 Pre-Pour Operations	4.3.3 Positioning of Reinforcement	Plants shall maintain a documented process of reinforcing steel / cage inspections including information on the required cage design vs the actual cage used; including the following: Bar size and/or WWR bar diameter; Bar spacing and/or WWR style; The quantity of bars; (Inspections may include one or more of the above per detailed reinforcing steel plan documents); The effective depth (d), (the distance from the compressive face to the centroid of the tensile reinforcement member); The concrete cover, never less than ½" clear; The development length; Cage dimensions: length, width, height, and/or diameter, as applicable; Reinforcing steel condition: Clean or light red rust, not flaking or pitted; Free from oils, dirt, or other contaminants; If welded, meets the requirements of section 4.2.2; If welded, does not contain any damage, such as gouges and undercut; Reinforcement hooks and bends (90° and 180°). If design, project specifications, and/or detailed reinforcing steel plans require a bend in reinforcing steel around a corner, substitution of straight sections tied together shall not be acceptable practice. A detailed inspection is required on one piece or 3% produced unless the product is machine-cast or dry-cast. (See section 4.1.5 for reinforcement in machine-cast or dry-cast products). Documentation of the inspection can be on a piece or production shift basis and must be documented daily.	Reinforcing steel checks are not performed at all [or one or more of the following] Reinforcing steel checks are performed, but not consistently [deduction based on estimated % of checks not performed] {if less than 75% of products 100% deduction} Reinforcing steel checks performed incorrectly / measurements not accurate Required data is missing from documentation, or is not measured {if less than 75% of products 100% deduction} Reinforcing steel inspection documentation is missing from the file {if less than 75% of products 100% deduction} Welded reinforcing steel does not follow 4.2.2 Reinforcing steel is dirty, oily, or has pitted or flaking rust Reinforcing steel hooks and / or bends are not correct Insufficient quantity of reinforcing steel inspections {if less than 75% of products 100% deduction}	100% Estimate % 100% Estimate % Estimate % 100% 25% 100% Estimate %



General Grading Philosophy

- If the plant is meeting all the requirements at the proper frequencies, the records are well organized and easily retrieved, and no problems with that item are noted, they should be given a score of 100 percent for that item.
- Double deductions for major infractions / deficiencies
- The lowest possible score for each section is zero

- The following standard deductions should be subtracted from a grade of 100% for that particular section, assuming that no other deficiencies are noted.

Section	Subsection	General Comments & Grading	Common Deficiencies	Deduction(s)
5.3 Concrete Testing	5.3.1 Slump, Slump Flow, and VSI	Fresh concrete tests should be performed at the required frequencies for each mix design used at the plant. Upon discovering a test result that is out of tolerance, the plant must take action to correct the non-conformance.	Testing not performed at all [choose this option or one or more of the following] Testing not performed at proper frequency Testing not performed correctly Measured test results out of tolerance - no corrective action taken { no action taken 25% deductions} Slump or slump flow test documentation is missing from files	100% % of sample 100% 25.0% % of sample
	5.3.2 Temperature	Upon discovering a test result that is out of tolerance, the plant must take action to correct the non-conformance.	Temperature testing not performed at all [or one or more of the following] Temperature testing not performed at proper frequency Temperature testing not performed correctly Measured temperature out of tolerance - no corrective action taken {no action taken 25% deductions} Temperature testing documentation missing from file	100% % of sample 100% 25.0% % of sample
	5.3.3 Density (Unit Weight)	Upon discovering a test result that is out of tolerance, the plant must take action to correct the non-conformance.	Density testing not performed at all [or one or more of the following] Density testing not performed at proper frequency Density testing not performed correctly Measured test results out of tolerance - no corrective action taken { no action taken 25% deductions} Density testing documentation missing from file	100% % of sample 100% 25.0% % of sample
	5.3.4 Air Content	Upon discovering a test result that is out of tolerance, the plant must take action to correct the non-conformance.	Air content testing not performed at all on air entrained concrete [or one or more of the following] Air content testing not performed at proper frequency Air content testing not performed correctly Measured air content out of tolerance - no corrective action taken {no action taken 25% deductions} Air content testing documentation missing from file	100% % of sample 100% 25.0% % of sample
	5.3.5 Compressive Strength	Compressive strength testing may be stopped upon reaching the design strength plus 10 percent. Testing to cylinder failure (crushing) must be performed at least once per month.	Compressive strength testing not performed at all [or one or more of the following] Compressive strength testing not performed at proper frequency Compressive strength specimen not cast or cured correctly Compressive strength specimen not tested correctly Measured compressive strength out of tolerance - no corrective action taken { no action taken 25% deductions} Number of specimen cast insufficient Compressive strength testing documentation missing from file {if less than 75% of products 100% deduction}	100% % of sample 100% 100% 25.0% 100% Estimate %

NPCA Quality Control Manual for Precast Concrete Plants
Standardized Grading System for Critical Requirements, 14th Edition

General Grading Philosophy

- If the plant is meeting all the requirements at the proper frequencies, the records are well organized and easily retrieved, and no problems with that item are noted, they should be given a score of 100 percent for that item.
- Double deductions for major infractions / deficiencies
- The lowest possible score for each section is zero



- The following standard deductions should be subtracted from a grade of 100% for that particular section, assuming that no other deficiencies are noted.

6.2.1 Stormwater Concrete Pipe Requirements	This section does not apply to sanitary pipe			
	6.2.1.1 Reinforcing Steel Inspection	All reinforcing steel cages should be checked by plant personnel for conformance to the design. For the sake of simplicity, 1 reinforcing steel cages or 3% of each production run should be checked on a random basis, regardless of whether or not they are fabricated with mechanized equipment.	Reinforcing steel checks are not performed at all [or one or more of the following] Reinforcing steel checks are performed, but not consistently [deduction based on estimated % of checks not performed] {if less than 75% of products 100% deduction} Reinforcing steel checks performed incorrectly / measurements not accurate Required data is missing from documentation, or is not measured Reinforcing steel inspection documentation is missing from the file {if less than 75% of products 100% deduction}	100% Estimate % 100% 20% / element Estimate %
	6.2.1.2 Three-Edge Bearing Testing	Testing should be performed on each size and class of pipe produced at the plant, up to 60 inches in diameter. Unless testing to ultimate strength, it is not necessary to load the pipe beyond the ASTM-specified D-Load to produce a 0.01-in. crack.	TEB testing not performed at all [or one or more of the following] TEB testing not performed at proper frequency [deduction based on estimate % of TEB testing not performed] {if less than 75% of products 100% deduction} TEB testing not performed correctly TEB test documentation incomplete The plant is unable to test large diameter pipe due to the physical limitations of the test equipment	100% Estimate % 100% 100% 100%
6.2.1.3 Absorption Testing	Absorption testing should be performed on both wet- and dry-cast mixes, with the lowest amount of cementitious material.	Absorption testing is not performed at all [or one or more of the following] Absorption testing is performed, but not at the required frequency {if less than 75% of products 100% deduction} Absorption testing is not performed correctly Absorption testing documentation is incomplete or missing from the plant files	100% Estimate % 100% 100%	
6.2.2 Sanitary Concrete Pipe Requirements	This section does not apply to stormwater pipe			
	6.2.2.1 Reinforcing Steel Inspection	All reinforcing steel cages should be checked by plant personnel for conformance to the design. For the sake of simplicity, 1 reinforcing steel cages or 3% of each production run should be checked on a random basis, regardless of whether or not they are fabricated with mechanized equipment.	Reinforcing steel checks are not performed at all [or one or more of the following] Reinforcing steel checks are performed, but not consistently [deduction based on estimated % of checks not performed] {if less than 75% of products 100% deduction} Reinforcing steel checks performed incorrectly / measurements not accurate Required data is missing from documentation, or is not measured Reinforcing steel inspection documentation is missing from the file {if less than 75% of products 100% deduction}	100% Estimate % 100% 20% / element Estimate %
	6.2.2.2 Three-Edge Bearing Testing	Testing should be performed on each size and class of pipe produced at the plant, up to 60 inches in diameter. Unless testing to ultimate strength, it is not necessary to load the pipe beyond the ASTM-specified D-Load to produce a 0.01-in. crack.	TEB testing not performed at all [or one or more of the following] TEB testing not performed at proper frequency [deduction based on estimate % of TEB testing not performed] {if less than 75% of products 100% deduction} TEB testing not performed correctly TEB test documentation incomplete The plant is unable to test large diameter pipe due to the physical limitations of the test equipment	100% Estimate % 100% 100% 100%
6.2.2.3 Absorption Testing	Absorption testing should be performed on both wet- and dry-cast mixes, with the lowest amount of cementitious material.	Absorption testing is not performed at all [or one or more of the following] Absorption testing is performed, but not at the required frequency {if less than 75% of products 100% deduction} Absorption testing is not performed correctly Absorption testing documentation is incomplete or missing from the plant files	100% Estimate % 100% 100%	



General Grading Philosophy

- If the plant is meeting all the requirements at the proper frequencies, the records are well organized and easily retrieved, and no problems with that item are noted, they should be given a score of 100 percent for
- Double deductions for major infractions / deficiencies
- The lowest possible score for each section is zero

- The following standard deductions should be subtracted from a grade of 100% for that particular section, assuming that no other deficiencies are noted.

Section	Subsection	General Comments & Grading	Common Deficiencies	Deduction(s)
6.3 Round Manhole Component Requirements	6.3.1 Reinforcing Steel Inspection	All reinforcing steel cages should be checked by plant personnel for conformance to the design. For the sake of simplicity, 1 reinforcing steel cages or 3% of each production run should be checked on a random basis, regardless of whether or not they are fabricated with mechanized equipment.	Reinforcing steel checks are not performed at all [or one or more of the following] Reinforcing steel checks are performed, but not consistently [deduction based on estimated % of checks not performed] {less than 75% of product then 100% deduction} Reinforcing steel checks performed incorrectly / measurements not accurate Required data is missing from documentation, or is not measured Reinforcing steel inspection documentation is missing from the file {less than 75% of product then 100% deduction}	100% Estimate % 100% 20% / element Estimate %
	6.3.3.1 Absorption Testing	Absorption testing should be performed on both wet- and dry-cast mixes, with the lowest amount of cementitious material.	Absorption testing is not performed at all [or one or more of the following] Absorption testing is performed, but not at the required frequency {if less than 75% of products 100% deduction} Absorption testing is not performed correctly Absorption testing documentation is incomplete or missing from the plant files	100% Estimate % 100% 100%
6.4 Box Culvert Requirements	6.4.3 Pre-Pour Inspections	Critical form dimensions, including top, bottom and wall thicknesses, should be measured and documented for both wet- and dry-cast box culverts. In addition, reinforcing steel inspections should be performed and documented.	Form dimensions are not measured / checked at all on box culverts [or one or more of the following] Form dimensions are measured, but not at required frequency [deduction based on estimated % of checks not performed] {less than 75% of product then 100% deduction} Required form dimension data is missing from documentation, or is not measured Form dimension documentation is missing from the file Reinforcing steel checks are not performed at all [or one or more of the following] Reinforcing steel checks are performed, but not consistently [deduction based on estimated % of checks not performed] {less than 75% of product then 100% deduction} Reinforcing steel checks performed incorrectly / measurements not accurate Required data is missing from documentation, or is not measured Reinforcing steel inspection documentation is missing from the file {less than 75% of product then 100% deduction}	100% Estimate % 20% / element 20% / element 100% Estimate % 100% 20% / element Estimate %
	6.4.4 Dimensional Checks	These dimensional checks should be performed at the same time as the post-pour inspection	Product dimensions are not measured / checked at all on box culverts [or one or more of the following] Product dimensions are measured, but not at required frequency [deduction based on estimated % of checks not performed] {less than 75% of product then 100%} Required product dimension data is missing from documentation, or is not measured Product dimension documentation is missing from the file {less than 75% of product then 100% deduction}	100% Estimate % 20% / element Estimate %

NPCA Quality Control Manual for Precast Concrete Plants
Standardized Grading System for Critical Requirements, 14th Edition



General Grading Philosophy

- If the plant is meeting all the requirements at the proper frequencies, the records are well organized and easily retrieved, and no problems with that item are noted, they should be given a score of 100 percent for
- Double deductions for major infractions / deficiencies
- The lowest possible score for each section is zero

- The following standard deductions should be subtracted from a grade of 100% for that particular section, assuming that no other deficiencies are noted.

Section	Subsection	General Comments & Grading	Common Deficiencies	Deduction(s)
6.5 Septic Tank Requirements		The plant should have a listing of all forms that are used for casting onsite wastewater tanks. The listing should include information on the various design options the plant is capable of producing with each form. This listing will be used by the inspector to ensure that tanks from each of the forms have been tested and have the required documentation associated with them. In cases when multiple tank sizes are manufactured using the same form, structural testing should be performed on the largest (tallest) structure, as long as the same reinforcement design and concrete strength are used. Otherwise, testing should be performed on each tank design.		
	6.5.2 Watertightness Testing	Watertightness testing should be performed according to ASTM C1227, as a minimum. More stringent test protocol is acceptable, when required by the authority or authorities having jurisdiction	No watertightness testing is performed at the plant or no documentation exists on file [or one or more of the following] Watertightness testing documentation is available, but it is not available for all designs [deductions is based the % of documentation missing, as compared to the listing of forms and designs] {less than 75% of product then 100%} Watertightness testing documentation is missing information, such as dates, test values, etc.	100% Estimate % 20% / element
6.6 Grease Interceptor Requirements		The plant should have a listing of all forms that are used for casting grease interceptors. The listing should include information on the various design options the plant is capable of producing with each form. This listing will be used by the inspector to ensure that grease interceptors from each of the forms have been tested and have the required documentation associated with them. In cases when multiple interceptor sizes are manufactured using the same form, structural testing should be performed on the largest (tallest) structure, as long as the same reinforcement design and concrete strength are used. Otherwise, testing should be performed on each interceptor design.		
	6.6.2 Watertightness Testing	Watertightness testing should be performed according to ASTM C1613, as a minimum. More stringent test protocol is acceptable, when required by the authority or authorities having jurisdiction	No watertightness testing is performed at the plant or no documentation exists on file [or one or more of the following] Watertightness testing documentation is available, but it is not available for all designs [deductions is based the % of documentation missing, as compared to the listing of forms and designs] {less than 75% of product then 100%} Watertightness testing documentation is missing information, such as dates, test values, etc.	100% Estimate % 20% / element