



# Campaign Service

## BULLETIN

### IMPORTANT SERVICE INFORMATION FOR:

- ✓ SERVICE MANAGER
- ✓ SERVICE ADVISOR
- ✓ TECHNICIAN
- ✓ PARTS DEPARTMENT
- ✓ WARRANTY PERSONNEL

**BULLETIN NUMBER:**  
CB21-F-001B

**ISSUE DATE:**  
APRIL 2021

**GROUP:**  
SUSPENSION

## IMPORTANT SAFETY RECALL

**REAR AXLE U-BOLT NUTS INSPECTION – 21V-194**  
(Transport Canada 2021-168)

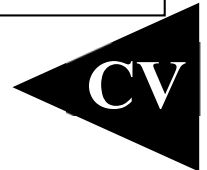

### AFFECTED VEHICLES

MY	Model	No. of Affected Vehicles
2015-2017	NPR Diesel Vehicles	3
2015-2017	NPR Stripped Chassis (Reach Van)	7
2016-2020	NPRHD Diesel Vehicles	27
2016-2020	NPRXD Diesel Vehicles	15
2016-2020	NQR Diesel Vehicles	29
2016-2021	NRR Diesel Vehicles	93

*This bulletin supersedes campaign bulletin CB21-F-001A. This bulletin has been updated to include US and Canada owner letters. Please discard previous campaign bulletin CB21-F-001A.*

### INFORMATION

#### CONDITION

Isuzu Motors Limited has decided that a defect, which relates to motor vehicle safety, exists in certain 2015-2021MY Isuzu N-Series Diesel vehicles. In the affected vehicles, the U-bolt nuts for the rear axle may not have been properly tightened at the manufacturing plant. The U-bolts and U-bolt nuts secure the rear axle to the leaf spring. If the U-bolt nuts loosen, the axle will initially be held in place by the leaf spring centering pin. With continued use, the axle can misalign with the centering pin, allowing the rear axle to move rearward and the propeller shaft to separate at its slip joint. If the propeller shaft separates, the rear wheels will not receive power from the engine and the vehicle will stall, increasing the risk of a crash.

#### CORRECTION

Isuzu dealers will inspect the rear U-bolt nuts. If any of the rear U-bolt nuts do not pass the inspection, the rear U-bolts, U-bolt nuts and washers (if applicable) are to be replaced. This service will be performed **free of charge**.

#### VEHICLES INVOLVED

Involved are certain 2015-2021MY Isuzu N-Series Diesel Vehicles

**Important:** Dealers are to confirm vehicle eligibility prior to beginning repairs by using IVIS (Isuzu Vehicle Information System).

For dealers with involved vehicles, a report of involved vehicles containing the complete vehicle identification numbers has been or will be provided. Dealers will not have a report available if they have no involved vehicles currently assigned.

## PARTS INFORMATION

If the Service Procedure below directs the technician to replace the U-bolts per **Step 6.a.**, parts should be ordered on a VOR (Vehicle Off Road) Order. Make sure you order the part numbers and quantities applicable to the specific vehicle model(s) according to the information below.

Model	Part Number	Description	Quantity
NPR	8-94127-924-3	U-Bolt	4
NPRHD	8-97360-118-0	Washer	8
NPRXD	8-97360-121-0	Nut	8
NQR	8-98128-783-0	U-Bolt	4
NRR	1-09440-039-1	Nut	8
NPR (Reach VAN)	8-94412-505-0	U-Bolt	4
	8-97360-118-0	Washer	8
	8-97360-121-0	Nut	8

## SERVICE PROCEDURE

1. Shift vehicle to park, turn off engine, set parking brake, and block rear wheels.
2. Locate the rear axles U-bolt mounting nuts. (See Figure 1.)

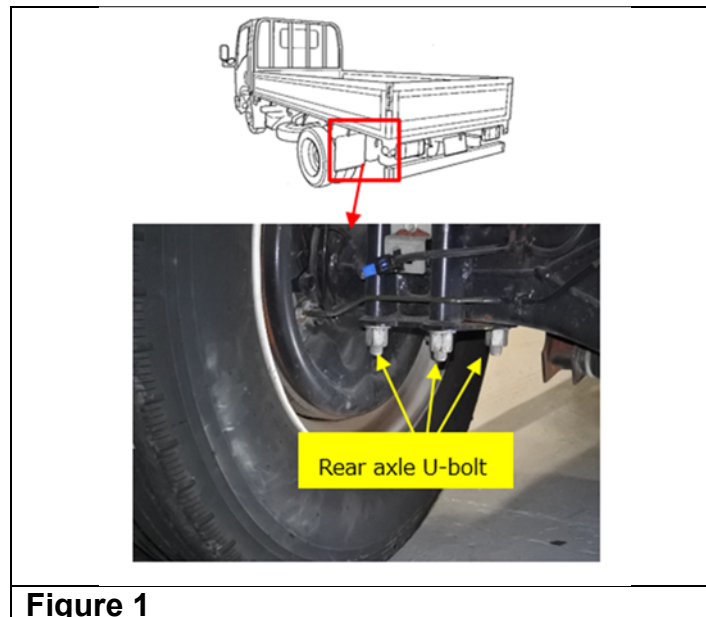

3. Using a rag or wire brush clean the U-bolt nuts and retainer plate surface.
4. Use a paint pen or small brush and paint to make an alignment mark on each nut, washer (if equipped), and the retainer plate in a straight vertical line as shown in Figures 2 & 3.

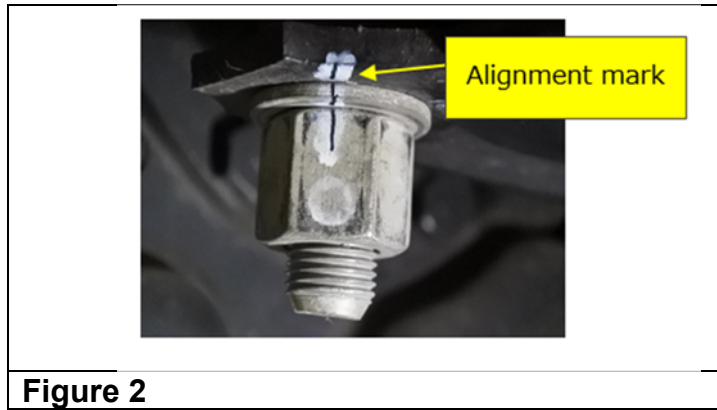

**Figure 2**

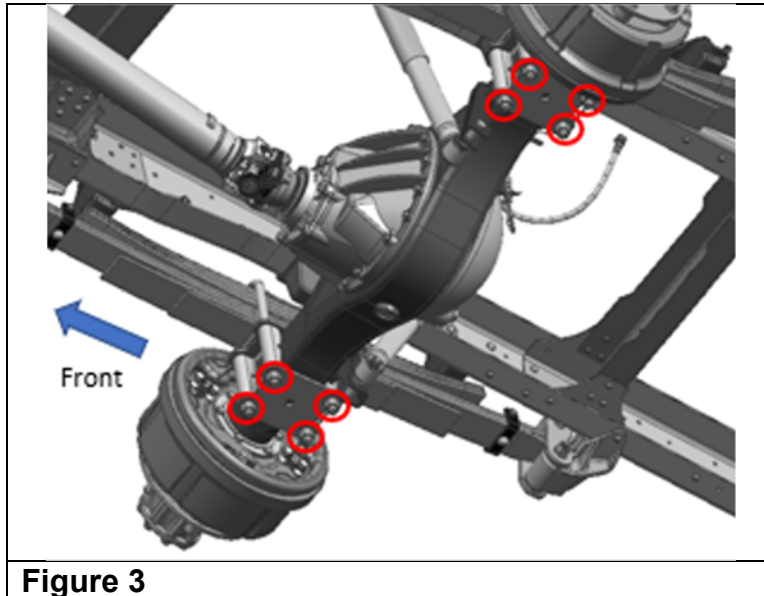

**Figure 3**

5. Use a torque wrench to tighten all eight (8) rear axle U-bolt nuts to 90 Nm (66 lb ft).
6. Inspect the painted alignment marks on all eight (8) rear axle U-bolt nuts.
  - a. If **ANY** of the painted marks are no longer aligned (See Figure 4), proceed to **Step 7** to replace the U-bolts and U-bolt nuts.
  - b. If **ALL** eight (8) of the rear axle U-bolt nut paint marks are still aligned (See Figure 2), proceed to **Applying the Campaign Label**.



**Figure 4**

## U-BOLTS AND U-BOLT NUTS REPLACEMENT

7. Loosen and remove the two (2) right hand side/forward rear axle nuts and washers (if applicable). (See Figure 5.) Lift the old U-bolt upwards to remove it.

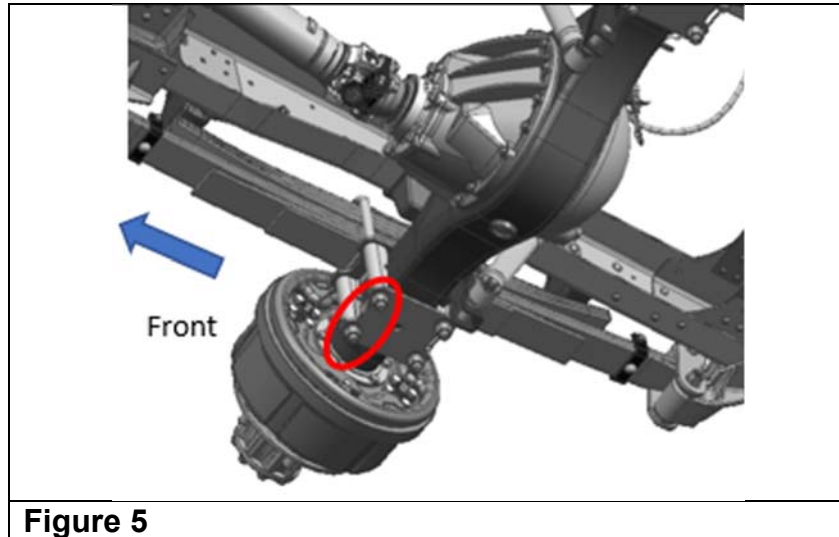

8. Install a *new* U-bolt in the same location from which the old U-bolt was removed in Step 7. Make sure the U-bolt is properly seated as shown in Figure 6.

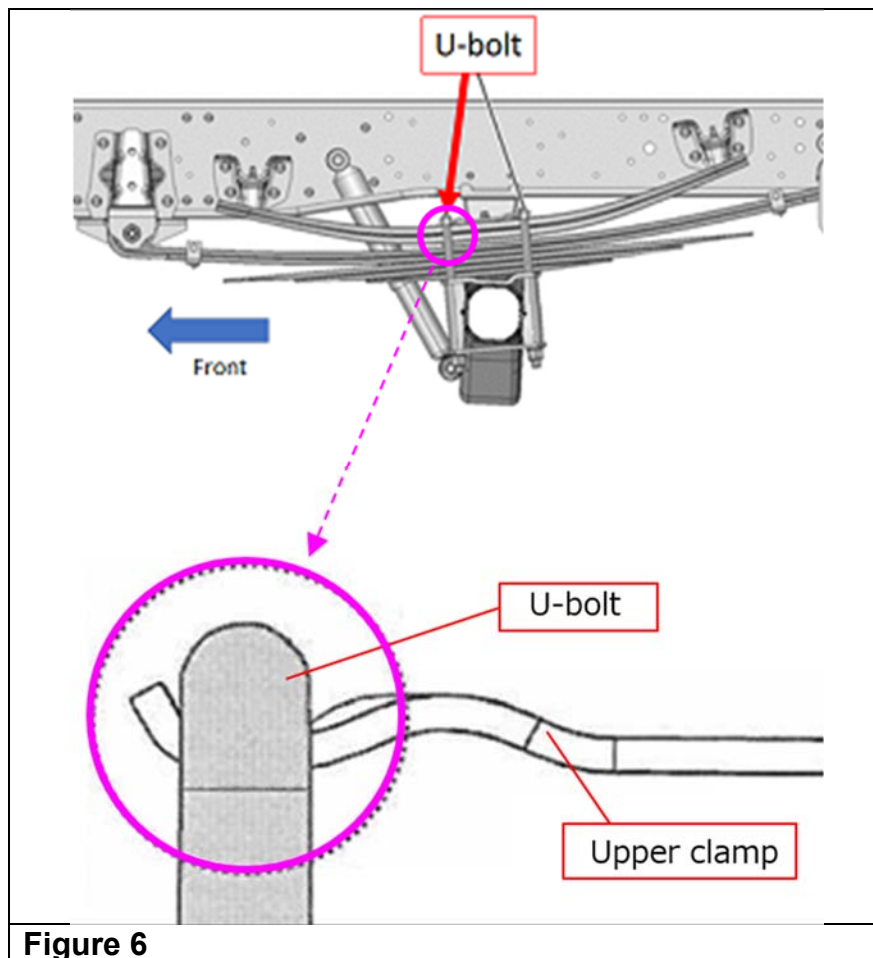

9. Place the two (2) *new* washers (if applicable) and two (2) *new* nuts onto the new U-bolt. **Use hand tools to lightly tighten each nut evenly.**
10. Use a torque wrench to alternately tighten the nuts to the specification shown in Table 1 below.

Vehicle Model	Tightening Torque
NPR/NPRHD/NPRXD/Reach Van	177 Nm (131 lb ft)
NQR/NRR	284 Nm (210 lb ft)

**Table 1**

**IMPORTANT: Ensure the U-bolt and U-bolt nuts are properly seated and tightened evenly so the U-bolt does not tilt.**

11. Measure the amount of U-bolt thread protruding from the U-bolt nut (A) and record your measurement. (See Figure 7.)
12. Measure the amount of U-bolt thread protruding from the U-bolt nut (B) and record your measurement. (See Figure 7.)
13. Determine the difference between measurements (A) and (B). The result should be 5mm or less.
  - a. If the difference between measurement (A) and (B) is 5mm or less, proceed to Step 14.
  - b. If the difference between measurement (A) and (B) is greater than 5mm, loosen both nuts and repeat Steps 10 – 13.

**IMPORTANT: The difference between measurements A and B must be 5mm or less.**

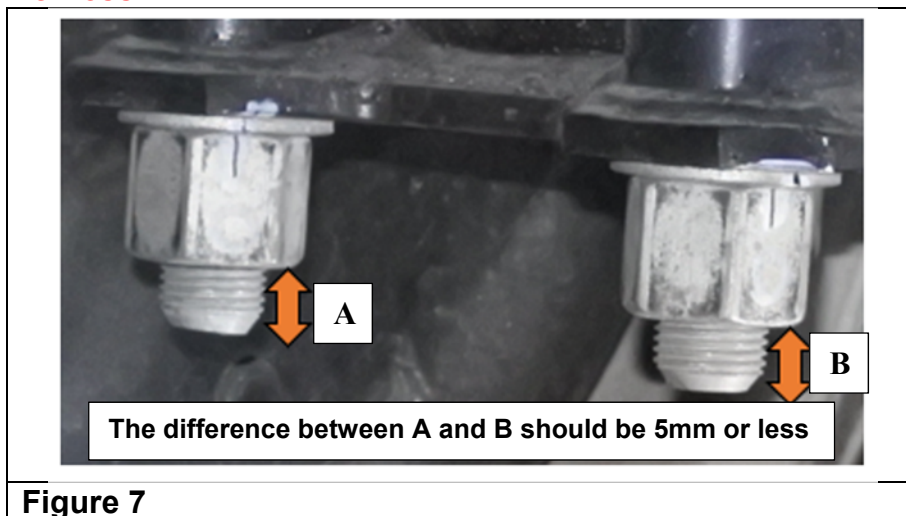

14. After replacing all four (4) U-bolts, proceed to **Applying the Campaign Label.**

## APPLYING THE CAMPAIGN LABEL

- Using a ball-point pen, fill in a campaign label (Part No. 2-90028-700-0) with Campaign Number 21V-194 (US) or 2021-168 (Canada), Isuzu dealer code, and repair date.
- Affix the campaign label onto the driver's side B-pillar.



The image shows a rectangular campaign label form. At the top, the word "ISUZU" is written in large, bold, red letters. Below it, "CAMPAIGN NUMBER" is written in smaller black letters. There are two horizontal lines for text entry. The first line is labeled "DEALER CODE:" and the second line is labeled "REPAIR DATE:". At the bottom of the form, the part number "PN 2-90028-700-0" is printed in small black letters.

## CLAIM INFORMATION

Refer to the Isuzu ICS Claims Processing Manual for details on Campaign Claim Submission. Submit only **one claim as indicated below.**

Labor Operation Code	Description	Labor Time
V2103	U-Bolt Torque Inspection Only	0.4*
V2103R	U-Bolt Torque Inspection & Replacement	1.3*

*\*Includes 0.1 hours for administrative allowance.*

## DEALER RESPONSIBILITY

Dealers are to service all vehicles subject to this campaign at no charge to customers, regardless of mileage, age of the vehicle, or ownership. Customers who have recently purchased vehicles sold from your vehicle inventory, and for which there is no customer information indicated on the dealer listing, are to be contacted by the dealer. Arrangements are to be made to perform the required correction according to the instructions contained in this bulletin. Program follow-up cards should not be used for this purpose, since the customers may not as yet have received the notification letter.

In summary, whenever a vehicle subject to this campaign enters your vehicle inventory, or is in your dealership for service, you must take the steps necessary to ensure the recall remedy has been implemented before selling or releasing the vehicle.

### Important:

As required by Federal law, dealers are not to deliver any new vehicle in their inventory, which is covered by a Safety Recall, until the necessary remedy has been performed.

Dealers are to confirm vehicle eligibility prior to beginning repairs by using IVIS (Isuzu Vehicle Information System). Not all vehicles may be involved.

For dealers with involved vehicles, a listing of involved vehicles containing the complete vehicle identification numbers has been or will be provided. Dealers will not have a report available if they have no involved vehicles currently assigned.

## OWNER NOTIFICATION

Samples of the recall letter that will be sent to owners of affected vehicles already retailed in the United States and Canada are attached below.



**IMPORTANT SAFETY RECALL**  
**NHTSA Recall 21V-194**

This notice applies to your vehicle, <VIN>

APRIL 2021

Dear Customer,

This notice is sent to you in accordance with the National Traffic and Motor Vehicle Safety Act. Your vehicle <VIN> <MY> model year Isuzu N-Series diesel vehicle is involved in safety recall NHTSA 21V-194.

**WHAT IS THE CONDITION?**

Isuzu Motors Limited has decided that a defect, which relates to motor vehicle safety, exists in certain 2015-2021MY Isuzu N-Series Diesel vehicles. In the affected vehicles, the U-bolt nuts for the rear axle may not have been properly tightened and may loosen, causing the axle to misalign. The misalignment may cause the propeller shaft to separate, causing a loss of power to the rear wheels and a stall, increasing the risk of a crash.

**WHAT WE WILL DO**

Isuzu dealers will inspect and, if needed, replace and tighten the rear axle U-bolt nuts. This service will be performed **free of charge**.

**WHAT YOU SHOULD DO**

We recommend that you contact your Isuzu dealer to schedule an appointment. Although not necessary, please present this Owner Notification Letter at the time of your appointment or refer to Campaign Service Bulletin CB21-F-001B. We estimate that the inspection may take 24 minutes to perform. However additional time may be required if the rear axle U-bolt nuts need to be replaced. To locate the nearest Isuzu dealer you can visit our website at [www.isuzucv.com](http://www.isuzucv.com) or contact our Customer Relations Department at the number listed below.

**Isuzu Commercial Truck of America**  
**Customer Relations**  
**1-866-441-9638**

**REIMBURSEMENT**

If you have already paid for repairs to address the condition covered by this safety recall, you may be eligible to have those costs reimbursed. The enclosed form explains the terms under which reimbursement may be available and how to request reimbursement.

If you have any difficulty having this recall performed, we recommend that you call Isuzu customer relations at 1-866-441-9638. If you are still not satisfied that we have remedied this situation without charge, and within a reasonable amount of time, you may wish to write to the Administrator of the National Highway Traffic Safety Administration, 1200 New Jersey Avenue, SE, Washington DC 20590, or call the agency's toll-free Vehicle Safety Hotline at 1-888-327-4236 (TTY: 1-800-424-9153), or go to <http://www.nhtsa.gov>.

We regret any inconvenience which this action may cause you.

Sincerely,

Isuzu Commercial Truck of America, Inc.

*Important: If you have sold or traded your Isuzu vehicle, please enter the owner's name and address, if known, on the attached "Change of Information" postcard, tear off at both perforations, and drop it in the mail. Postage has already been paid. We will contact the new owner.*

*Federal law requires that any vehicle lessor receiving this recall notice must forward a copy of this notice to the lessee within ten days. Lessor means a person or entity that is the owner, as reflected on the vehicle title, of any five or more leased vehicles.*

## IMPORTANT SAFETY RECALL

This notice applies to your vehicle, <VIN>  
<MY> model year ISUZU N-SERIES

APRIL 2021

Dear Customer,

This notice is sent to you in accordance with the requirements of the *Motor Vehicle Safety Act*. This is to inform you that your vehicle may contain a defect that could affect the safety of a person. Safety Recall Transport Canada 2021-168.

### WHAT IS THE CONDITION?

Isuzu Motors Limited has decided that a defect, which relates to motor vehicle safety, exists in certain 2016-2020MY Isuzu N-Series Diesel vehicles. In the affected vehicles, the U-bolt nuts for the rear axle may not have been properly tightened and may loosen, causing the axle to misalign. The misalignment may cause the propeller shaft to separate, causing a loss of power to the rear wheels and a stall, increasing the risk of a crash.

### WHAT WE WILL DO

Isuzu dealers will inspect and, if needed, replace and tighten the rear axle U-bolt nuts. This service will be performed **free of charge**.

### WHAT YOU SHOULD DO

We recommend that you contact your Isuzu dealer to schedule an appointment. Although not necessary, please present this Owner Notification Letter at the time of your appointment or refer to Campaign Service Bulletin CB21-F-001B. We estimate that the inspection may take 24 minutes to perform. However additional time may be required if the rear axle U-bolt nuts need to be replaced. To locate the nearest Isuzu dealer you can visit our website at [www.isuzutruck.ca](http://www.isuzutruck.ca) or contact our Customer Relations Department at the number listed below.

**Isuzu Commercial Truck of Canada  
Customer Relations  
1-866-441-9638**

### REIMBURSEMENT

If you have already paid for repairs to address the condition covered by this safety recall, you may be eligible to have those costs reimbursed. The enclosed form explains the terms under which reimbursement may be available and how to request reimbursement.

If you have questions or concerns that your Isuzu dealer is unable to answer, please contact our Customer Relations Department at 1-866-441-9638.

We regret any inconvenience which this action may cause you.

Sincerely,

Isuzu Commercial Truck of Canada, Inc.

*Important: If you have sold or traded your Isuzu vehicle, please enter the owner's name and address, if known, on the attached "Change of Information" postcard, tear off at both perforations, and drop it in the mail. Postage has already been paid. We will contact the new owner.*

*Federal law requires that any vehicle lessor receiving this recall notice must forward a copy of this notice to the lessee within ten days. Lessor means a person or entity that is the owner, as reflected on the vehicle title, of any five or more leased vehicles.*



## Customer Reimbursement Claim Form

If you have paid to have this condition corrected prior to this notification, you may be eligible to receive reimbursement. Requests for reimbursement may include parts, labor, fees and taxes. Reimbursement may be limited to the amount the repair would have cost if completed by an authorized service facility.

Your claim will be acted upon within 60 days of receipt.

This section to be completed by Claimant

Date Claim Submitted: \_\_\_\_\_

17-Digit Vehicle Identification Number (VIN): \_\_\_\_\_

Mileage at Time of Repair: \_\_\_\_\_ Date of Repair: \_\_\_\_\_

Claimant Name (please print): \_\_\_\_\_

Street Address or PO Box Number: \_\_\_\_\_

City: \_\_\_\_\_ State: \_\_\_\_\_ ZIP Code: \_\_\_\_\_

Claimant Email: \_\_\_\_\_

Daytime Telephone Number (include Area Code): \_\_\_\_\_

Evening Telephone Number (include Area Code): \_\_\_\_\_

Amount of Reimbursement Requested: \$ \_\_\_\_\_

The following documentation must accompany this claim form.

Original or clear copy of all receipts, invoices, and/or repair orders that show:

- The name and address of the person who paid for the repair.
- The Vehicle Identification Number (VIN) of the vehicle that was repaired.
- What problem occurred, what repair was done, when it was done, and who did it.
- The total cost of the repair expense that is being claimed.
- Payment for the repair in question and the date of payment.  
(copy of front and back of cancelled check, or copy of credit card receipt)

My signature to this document attests that all attached documents are genuine and I request reimbursement for the expense I incurred for the repair covered by this letter.

Claimant's Signature: \_\_\_\_\_

If your claim is:

- Approved, you will receive a check,
- Denied, you will receive a letter with the reason(s) for the denial, or
- Incomplete, you will receive a letter identifying the documentation that is needed to complete the claim and offered the opportunity to resubmit the claim when the missing documentation is available.

Please mail this claim form and the required documents to:

**Isuzu Commercial Truck Customer Relations**  
**1400 S. Douglass Road, Suite 100**  
**Anaheim, CA 92806**

Reimbursement questions should be directed to the following number:

1-866-441-9638

Or Email: [cvcs@icta-us.com](mailto:cvcs@icta-us.com)