

Research Article

Numerical Investigation on Ballistic Limit Velocity of Armour Materials

Suresh Periyasamy[#], Ramabalan Sundaresan[^] and Natarajan Uthirapathy[!]

[#]Department of Mechanical Engineering, Aurora's Technological and Research Institute, Parvathapur, Hyderabad - 500 098, Telangana, India

[^]Department of Mechanical Engineering, E.G.S. Pillay Engineering College, Nagapattinam - 611 002, Tamil Nadu, India

[!]Department of Mechanical Engineering, Alagappa Chettiyar College of Engineering & Technology, Karaikudi - 630 004, Tamil Nadu, India

Received 15 March 2018, Accepted 19 May 2018, Available online 23 May 2018, Vol.8, No.3 (May/June 2018)

Abstract

The Threats to public security and premises security are on the rise because of increasing terrorism and violence. Safety of individual is a matter of concern, hence there is need to develop bullet resistant solutions for soldiers, tanks, and other military vehicles. This case study is concerned with designing the plates which are made up of different materials and structures and finding the ballistic limit velocity (BLV) by analyzing and comparing them. In this work, the ballistic limit velocity of Al 7075-T6, Al 5083H116, Titanium, Kevlar 149 materials were investigated numerically. Initially single layer plates made of Al 5083H116, Al 7075-T6 and Titanium were analyzed individually and it was found that Titanium plate yielded better ballistic limit velocity value than the other two materials. The numerical work was further extended with sandwich structures with / without honeycomb core. Al 7075-T6 material was considered for the front and rear face of the sandwich armour. And for the core portion Kevlar 149 (without honeycomb) & Al 7075-T6 (with honeycomb) were considered. Commercial software Ansys-workbench was used through the analysis. The result of the case study indicated that Al 7075-T6 with honeycomb structure yields greater ballistic limit velocity and it has 22.58% more BLV value than the solid single layer Al 7075-T6.

Keywords: Ballistic limit velocity, honeycomb, armour, sandwich structure, bullet, Analysis

1. Introduction

Generally, impact problems were of primary concern to the military, either for defensive or offensive purposes to develop armour or ammunition. Nowadays, civilian applications demand extreme safety of the products, therefore, it is essential to understand the material behaviour under intense short duration or impact loadings. Obviously, using metallic armour for personal protection is extremely heavy and would not be popular. Hence, reinforced fibre composites have been used for these purposes, but have been shown to be very susceptible to impact damage, thus limiting their usefulness for such an application.

Ballistics is the science of mechanics that mainly deals with the acceleration of the projectile in the gun barrel, behaviour of projectile at the muzzle and during flight, its effects on the target. It is generally separated into three branches which are interior, exterior and terminal ballistics.

The velocity necessary for a bullet to reliably penetrate a particular piece of material is known as ballistic limit velocity (BLV). In other words, a given projectile will generally not pierce a given target when

the projectile velocity is lower than the ballistic limit. The term ballistic limit is used specifically in the context of armour. The minimum velocity at which an armour piercing projectile is expected to consistently and completely penetrate an armour plate of given thickness is called the ballistic limit velocity of that armour plate. The ballistic limit velocity of different plates have been fixed in such a way that the bullet does not penetrate through the plate and it does not create a hole on the plate. If the velocity of bullet is greater than the ballistic limit velocity of the material, then it will reliably penetrate onto the plate and create a hole. On the other hand, if the velocity of the bullet is lower than the ballistic limit velocity, then the bullet will pierce through a very small thickness onto the plate. In this context, this article reports the numerical methods to identify the ballistic limit velocity of armour materials using different materials and structure.

2. Literature review

The literature has been reviewed from the perspective of improving the ballistic limit velocity of armour materials by adopting the different materials and structure.

*Corresponding Author's ORCID ID: 0000-0002-9612-4467
DOI: <https://doi.org/10.14741/ijcet/v.8.3.18>

(Sujith *et al*, 2015) has explained the Finite element analysis carried out on three materials that is Boron fiber, Kevlar 149 and Spectra 900 to determine the deformations and stresses when it is struck with a high bullet velocity of 950m/sec. From the results and tabulations it is evident that Spectra 900 fibers are the best when compared to Boron and Kevlar 149 with minimum deformation and stresses when subjected to bullet impact. Spectra 900 based composites are having the desired mechanical properties like higher strength, resistance to chemical reactions, negligible moisture sensitivity.

(Amelie Kolopp *et al*, 2013) has insisted that in order to identify potential solutions of sandwich structures subjected to impacts, several points have to be underlined:

- 1) The front skin choice is very important for the target perforation resistance. Aluminium and dry fabric are potential candidates and have been tested in this study as front skin.
- 2) The target dimension influences the impact performance. 300mm side targets are representative of real structures but this is not the case with 200mm side samples and deformations of the target edges and momentum of the target near the support.

(Artero-Guerrero *et al*, 2013) has explained that a higher velocity impact produces higher pressure peaks in shock phase and also a larger cavity. Therefore, more damaging Hydrodynamic Ram (HRAM) effects, as it is shown in experimental and numerical tests. The relation between magnitude of pressure pulse and impact velocity is quadratic, while maximum cavity size is linear.

(Bernetic *et al*, 2016) has investigated and analyzed the ballistic properties of armour steel plate PROTAC500 against armoured piercing bullets calibre 7.62mm. The most palpable and noteworthy phenomena in penetrating of the piercing bullets Nammo AP8 in steel target PROTAC 500 are strain hardening of steels, adiabatic shear bands with related phase transformations, the form of cracks and local failure, and melting as well as alloying at the border of the bullet and the steel plate.

(Mamivand and Liaghat, 2010) have insisted that Ballistic impact behaviour of multi-layer woven fabric must be studied. By considering dynamic material properties for fabric, the present model can predict ballistic limit for multi-layer fibrous targets with high accuracy. Investigation of layer spacing effect on target performance shows a threshold for gap decoupling. Increasing the gap more than this value will have no effect on target ballistic performance.

(Satish ramavat *et al*, 2012) has conducted the bullet impact analysis on steel plate by FEA in Radioss and by physical testing. The matching results of FEM simulation using Radioss and physical testing of steel plates are very much encouraging to use Radioss as a tool to check the performance of bullet resistance. Also, the study has exposed that the predictive capability for

penetration of steel core bullet is relatively good with Radioss explicit non-linear analysis. Moreover, it also helps to get the steel plate behavior under dynamic impact loading. It has been shown that the simulations could catch the main features of the experiments (especially the velocity, and kinetic energy of the projectile).

(Jung Seop Lim, 2013) has performed a study on two Heracron woven fabrics, HT840-1 and HT840-2, which were fabricated with different multifilament fibers, and their resistance to ballistic impact was investigated. For the same number of plies and weight, the HT840-2 fabric showed improved ballistic properties, compared with HT840-1; their result is contrary to the fiber and fabric properties. With the exception of the yarn's physical properties, this behavior can be explained in terms of the number of multifilament's, which strongly influences the ballistic mechanism, *i.e.*, a greater number of multifilament fibers facilitates energy dissipation from a high-speed ballistic projectile. In summary, establishing this optimal number of multifilaments is the key to optimizing the ballistic properties of any given fabric.

(Vaibhav Dangwal and Saurabh Gairola, 2014) have presented reports on ballistic simulation of impact problems for the assembly of Plexi glass and Float glass sheets arranged alternatively. The ballistic impact caused by bullet of AK47 rifle has been analyzed to obtain an estimate for the global damage. All approximations have been carried out using the finite difference numerical code Autodyn-3D. This assemblage made of floatglass and plexiglass sheets arranged in alternate order can take a bullet impact, without getting damaged significantly. It can thus be incorporated in car windows, windscreens, offices, etc, where bullet resistant characteristics are desired. It has a total thickness of 1.5 inches (each plate is 7.62 mm thick), which is optimum, keeping in mind that plexiglass is a cheaper substitute of polycarbonate, which is usually used with glass for bullet proofing solutions, when extreme strength is required but it is expensive.

To date, there are many evidences of design and development of such materials by using design and analysis software packages. But, this article attempts to explore the methods to be adopted for the improvement of armour material to safeguard the soldiers.

3. Research Methodology

The methodology followed in this project is shown in Figure 1. The project starts with the identification of problem on armour materials, literature review. Then the design and analysis of the bullet, plate and honeycomb structure has been carried out using Creo 2.0 and Ansys R15.0. Then the ballistic limit velocity of the different materials and structures has been measured and compared.

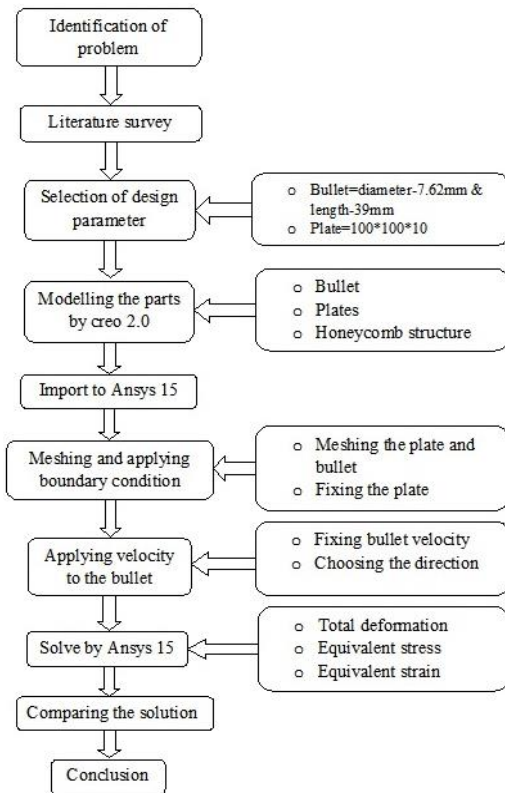

Fig.1 Research Methodology

4. Case study

In this case study, the ultimate aim is to find the better ballistic limit velocity of the materials with different structures. In similar studies, the material properties are changed to achieve better ballistic limit. We have tried different materials with different structures, like single layer plate, sandwiches, honeycomb etc.

In the first three cases, we have considered single layer plate with different materials like Al 7075-T6, Al 5083H116, and Titanium with the plate thickness of 10 mm. In the fourth case, we have taken sandwiches structure (without honeycomb) of 10 mm thickness with top and bottom layer of Al 7075-T6 with 2mm each and the core material as kevlar149 with 6mm. On further study, we considered the sandwiches structure with honeycomb of 10mm thickness with top and bottom layer of Al 7075-T6 with 2mm each (without honeycomb) and the core layer of Al 7075-T6 with 6mm (with honeycomb) to achieve the better ballistic limit velocity. The properties of various materials are shown in Table 1.

Table 1 Properties of various materials

Sl.No.	Material	Density (Kg/m ³)	Shear Modulus (Gpa)	Poisson's Ratio	Young's Modulus (Gpa)
1	Structural steel	7850	76.92	0.3	200
2	Al 5083H116	2700	26.92	0.33	71
3	Al 7075-T6	2804	26.7	0.33	71.7
4	Titanium	4510	5.34	0.342	113.8
5	Kevlar 149	1470	0.84559	0.36	186

4.1 Bullet design consideration

The spherical nose shaped bullet is made of lead material with the dimension of 7.62mm diameter and 39mm length is shown in Figure 2 and 3. The bullet is drawn in Creo software and then analyzed in Ansys software. Figure 2 represents the dimension of the bullet and Figure 3 shows the bullet design.

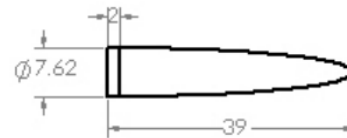

Fig.2 Bullet dimension

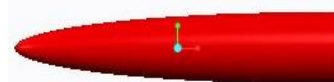

Fig.3 Bullet design

4.2 Plate design consideration

The single layer plate of dimension 100mm ×100mm is considered with thickness 10mm with above mentioned materials. On further study we just considered two additional structures like sandwiches (without honeycomb) and sandwiches (with honeycomb). The design details are shown in Table 2.

Table 2 Design details

S.No	Material	Structure	Layer	Thickness (mm)
1	AL 5083H116	Normal	1	10
2	AL 7075-T6	Normal	1	10
3	Titanium	Normal	1	10
4	AL 7075-T6 & Kevlar 149	Sandwiches	3	1 layer-2mm 2 layer-6mm 3 layer-2mm
5	AL 7075-T6	Sandwiches with Honeycomb	3	1 layer-2mm 2 layer-6mm 3 layer-2mm

Properties of materials like Al 7075-T6, Al 5083H116, Titanium, Kevlar 149 and structural steel are added to the engineering data and the IGS format of our design is imported. Materials are being assigned to the plates and the bullet and the four faces of the plates are fixed. The maximum element size of 1.5 mm is defined and coarse meshing is done. The end time of 0.00075 is declared, the four faces of the plate is fixed and the different velocities are applied and solved, to find the ballistic limit of each and every material. The results obtained are tabulated in Table 3.

4.3 Analysis solution

4.3.1. CASE 1: Al 5083 H116 – Normal structure

a. Velocity of bullet

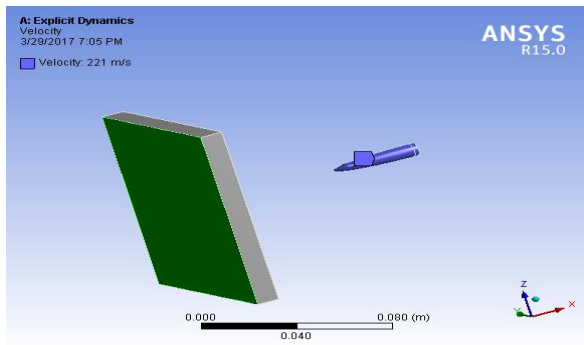

Fig.4 Bullet velocity:221m/s

Different velocities are applied to the bullet and at the velocity of 221m/s it has been found that the bullet does not penetrate through the plate and it does not create a hole in the plate. So it has been found that the ballistic limit velocity of Al5083H116 plate is 221m/s. It is shown in the Figure 4.

b. Total Deformation

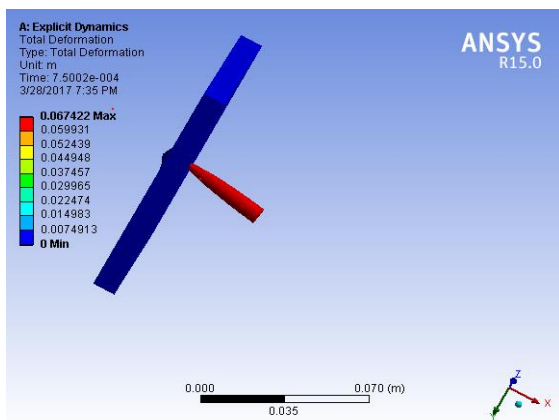

Fig.5 Total Deformation

Figure 5 shows the Total deformation of Al 5083 H116 - normal structure. It is found that the maximum deformation is 0.067422m and the minimum deformation is 0.0074913m.

c. Equivalent Strain

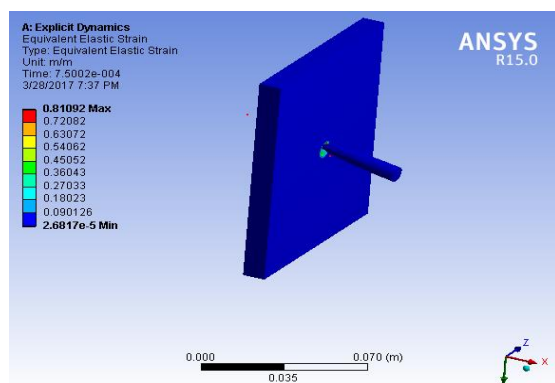

Fig.6 Equivalent Strain

Figure 6 shows the Equivalent Strain of Al 5083 H116 - normal structure. It is found that the maximum strain is 0.81092 and the minimum strain is 0.000026817.

d. Equivalent Stress

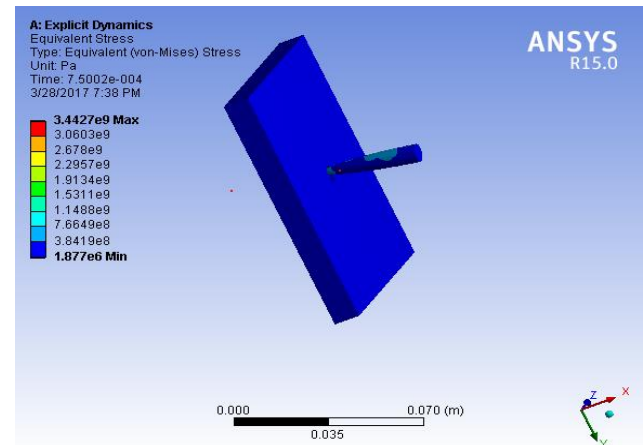

Fig.7 Equivalent Stress

Figure 7 shows the Equivalent Stress of Al 5083 H116 - normal structure. It is found that the maximum stress is 3.4427×10^9 pa and the minimum stress is 1.877×10^6 pa.

4.3.2. CASE 2: Al 7075-T6 – Normal structure

a. Velocity of bullet

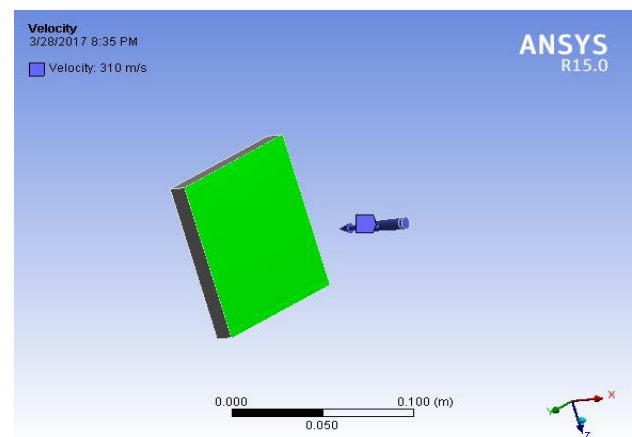

Fig.8 Bullet Velocity: 310m/s

Different velocities are applied to the bullet and at the velocity of 310m/s, it has been found that the bullet does not penetrate through the plate and it does not create a hole in the plate. So it has been found that the ballistic limit velocity of Al 7075-T6 plate is 310. It is shown in Figure 8.

b. Total Deformation

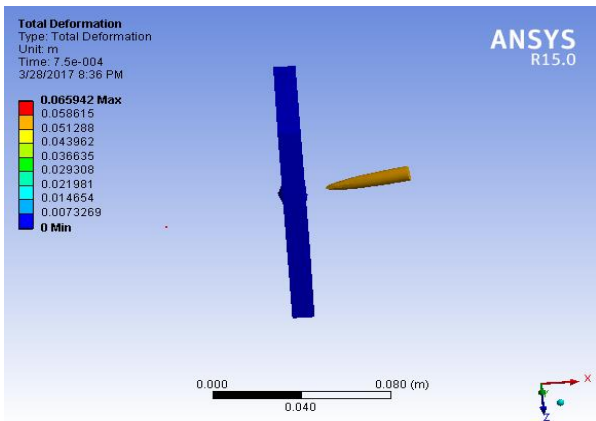

Fig.9 Total Deformation

Figure 9 shows the Total deformation of Al 7075-T6 - normal structure. It is found that the maximum deformation is 0.065942m and the minimum deformation is 0.0073269m.

c. Equivalent Strain

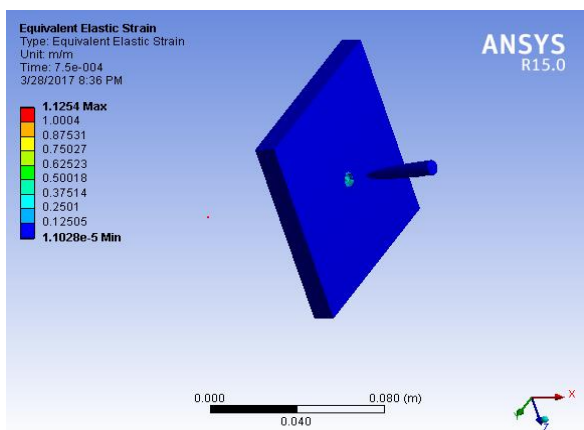

Fig.10 Equivalent Strain

Figure 10 shows the Equivalent strain of Al 7075-T6 - normal structure. It is found that the maximum strain is 1.1254 and the minimum strain is 1.1028×10^{-5} .

d. Equivalent Stress

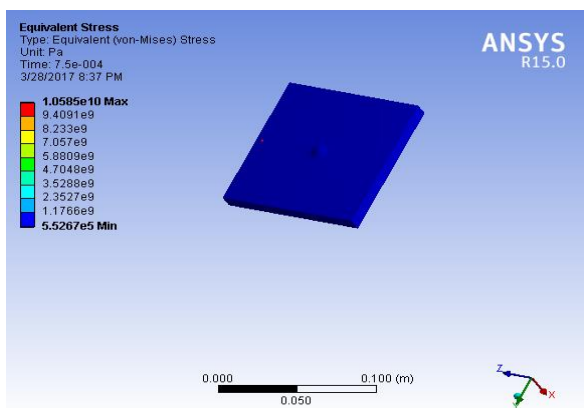

Fig.11 Equivalent Stress

Figure 11 shows the Equivalent stress of Al 7075-T6 - normal structure. It is found that the maximum stress is 1.0585×10^{10} pa and the minimum stress is 5.5267×10^5 pa.

4.3.3. CASE 3: Titanium - Normal Structure

a. Velocity of bullet

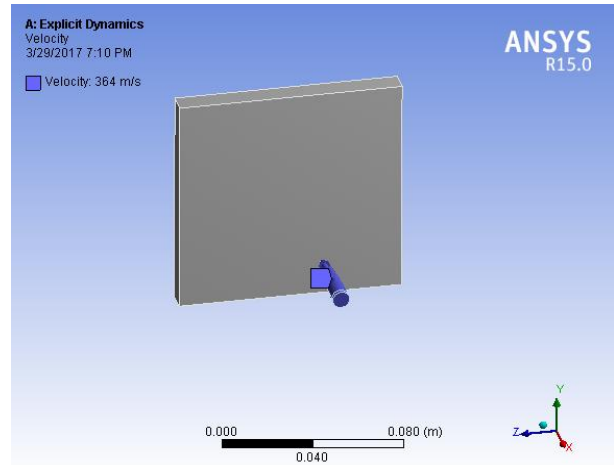

Fig.12 Bullet velocity: 364m/s

Different velocities are applied to the bullet and at the velocity of 364m/s, it has been found that the bullet does not penetrate through the plate and it does not created a hole in the plate. So it has been found that the ballistic limit velocity of titanium plate is 364m/s. It is shown in Figure 12.

b. Total Deformation

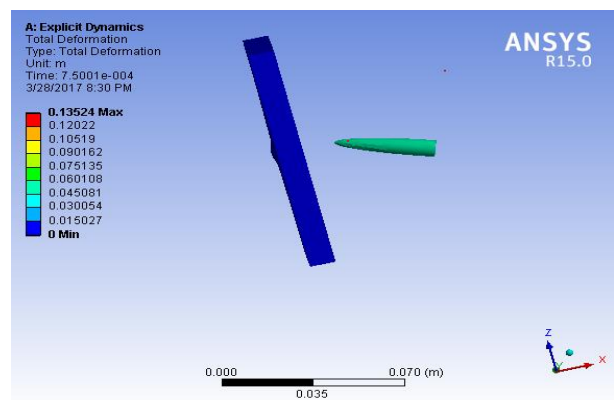

Fig.13 Total Deformation

Figure 13 shows the Total deformation of Titanium - normal structure. It is found that the maximum deformation is 0.13524m and the minimum deformation is 0.015027m.

c. Equivalent Strain

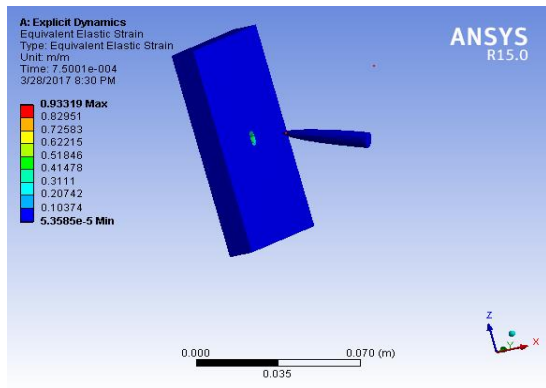

Fig.14 Equivalent Strain

Figure 14 shows the Equivalent strain of Titanium - normal structure. It is found that the maximum strain is 0.93319 and the minimum strain is 5.3585×10^{-5} .

d. Equivalent Stress

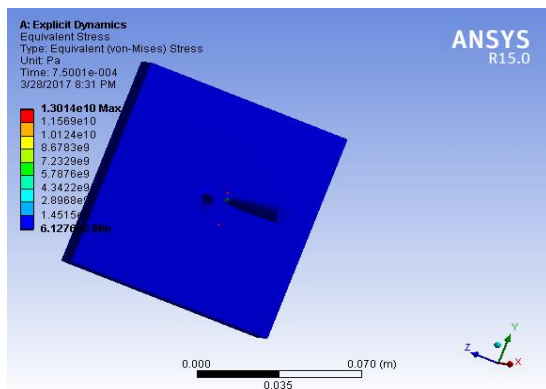

Fig.15 Equivalent Stress

Figure 15 shows the Equivalent stress of Titanium - normal structure. It is found that the maximum stress is 1.3014×10^{10} pa and the minimum stress is 6.1276×10^6 pa.

4.3.4. CASE 4: Sandwich (without honeycomb)

a. Velocity of bullet

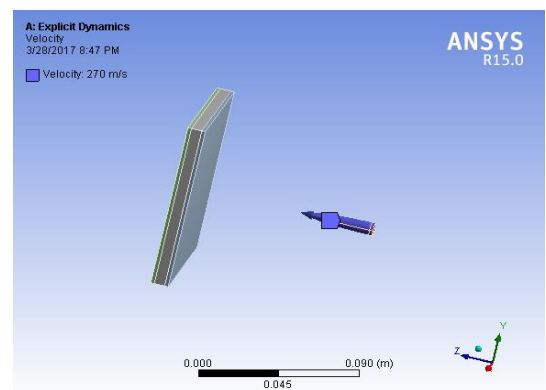

Fig.16 Bullet velocity: 270m/s

Different velocities are applied to the bullet and at the velocity of 270m/s, it has been found that the bullet does not penetrate through the plate and it does not create a hole in the plate. So it has been found that the ballistic limit velocity of sandwich structure (Al 7075-T6 & Kevlar 149) is 270m/s. It is shown in the Figure 16.

b. Total Deformation

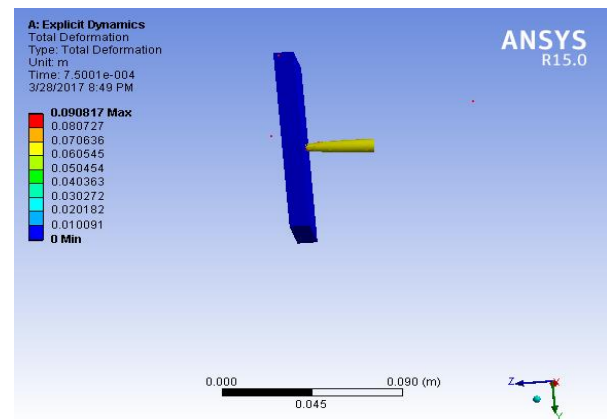

Fig.17 Total Deformation

Figure 17 shows the Total deformation of sandwiches (without honeycomb structure). It is found that the maximum deformation is 0.090817m and the minimum deformation is 0.010091m.

c. Equivalent Strain

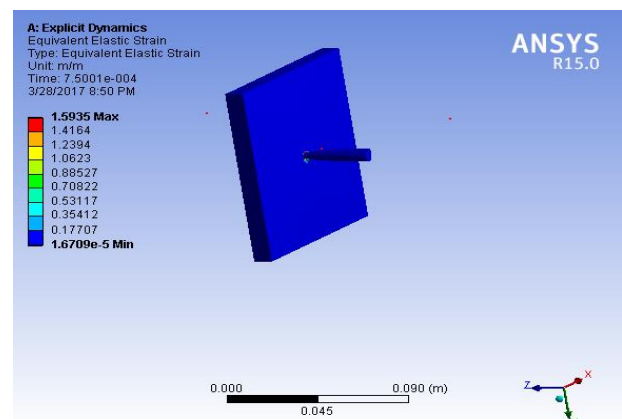

Fig.18 Equivalent Strain

Figure 18 shows the Equivalent strain of sandwiches (without honeycomb structure). It is found that the maximum strain is 1.5935 and the minimum strain is 1.6709×10^{-5} .

d. Equivalent Stress

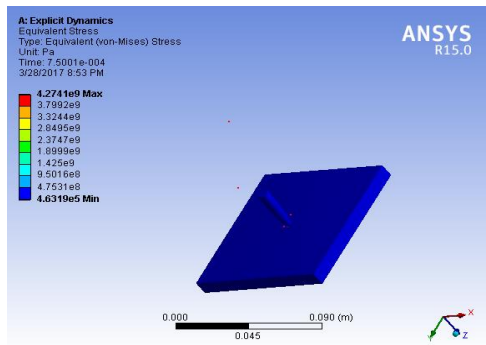

Fig.19 Equivalent Stress

Figure 19 shows the Equivalent stress of sandwiches (without honeycomb structure). It is found that the maximum stress is 4.2741×10^9 pa and the minimum stress is 4.6319×10^5 pa.

4.3.5. CASE 5: Sandwiches (with Honeycomb)

a. Velocity of bullet

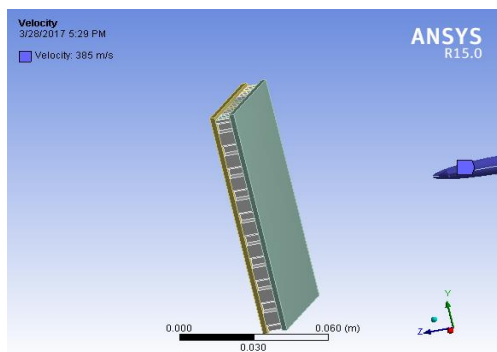

Fig.20 Bullet velocity:385m/s

Different velocities are applied to the bullet and at the velocity of 385m/s, it has been found that the bullet does not penetrate through the plate and it does not created a hole in the plate. So, it has been found that the ballistic limit velocity of sandwich structure with honeycomb core (Al 7075-T6) is 385. It is shown in Figure 20.

b. Total Deformation

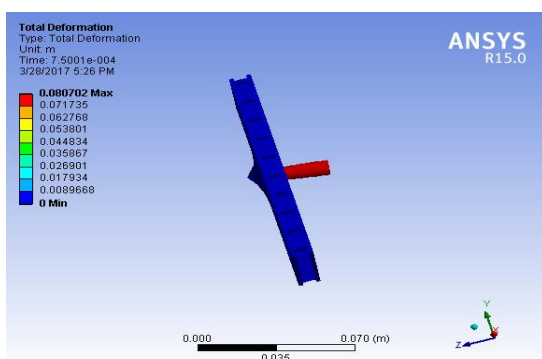

Fig.21 Total Deformation

Figure 21 shows the Total deformation of sandwiches (with honeycomb structure). It is found that the maximum deformation is 0.080702m and the minimum deformation is 0.0089668m.

c. Equivalent Strain

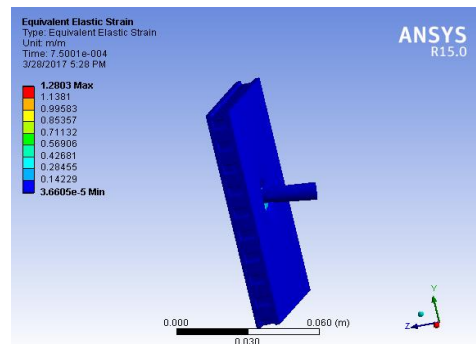

Fig.22 Equivalent Strain

Figure 22 shows the Equivalent strain of sandwiches (with honeycomb structure). It is found that the maximum strain is 1.2803 and the minimum strain is 3.6605×10^{-5} .

d. Equivalent Stress

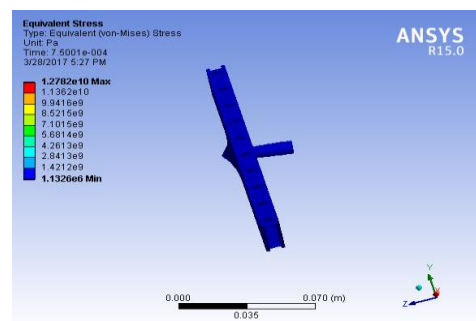

Fig.23 Equivalent Stress

Figure 23 shows the Equivalent stress of sandwiches (with honeycomb structure). It is found that the maximum stress is 1.2782×10^{10} pa and the minimum stress is 1.1326×10^6 pa.

5. Results and Discussions

The results obtained are shown in Table 3.

Table 3 Comparison of BLV for different materials

S No.	Type/ Material	BLV (m/s)	Total deformation (m)	Equivalent strain	Equivalent stress (Cpa)
1	Single Plate AL5083H116	221	0.06742	0.81092	3.4427
2	Single Plate AL7075-T6	310	0.06592	1.1254	10.585

3	Single Plate Titanium	364	0.13524	0.93319	13.014
4	Sandwiches Al 7075-T6 & Kevlar 149	270	0.0908	1.5935	4.2741
5	Sandwiches with Honeycomb Al 7075-T6	380	0.0807	1.2803	12.782

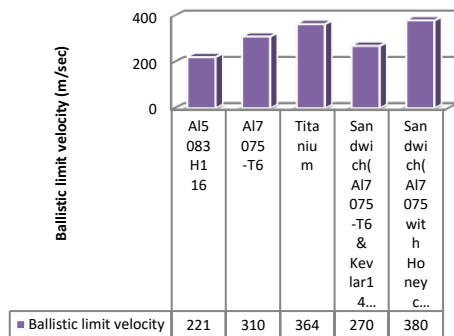

Fig.24 Comparison of BLV for different materials and structures

Figure 24 clearly shows that the ballistic limit velocity of Al 7075 - sandwich structure with honeycomb core yields a higher ballistic limit velocity of 380m/s, followed by Titanium, Al 7075-T6 and Al7075 - sandwich structure with Kevlar 149 core which has a ballistic limit velocity of 364, 310 and 270m/s respectively. It has been found that the Al5083-T6 has the least ballistic limit velocity of 221m/s.

5.1. Comparison of effect of bullet on plate at a bullet velocity greater and lower than ballistic limit velocity

In order to explain the effect of bullet on the plate at different velocities the following figures show the results obtained in the Ansys software. Figure 25 shows the impact of bullet on plate Al 5083-T6 at different velocities like 222,221,220 m/s.

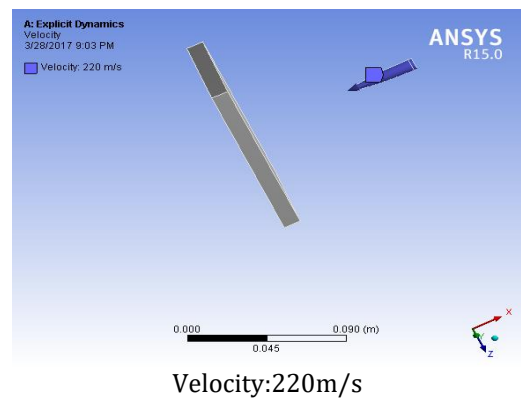
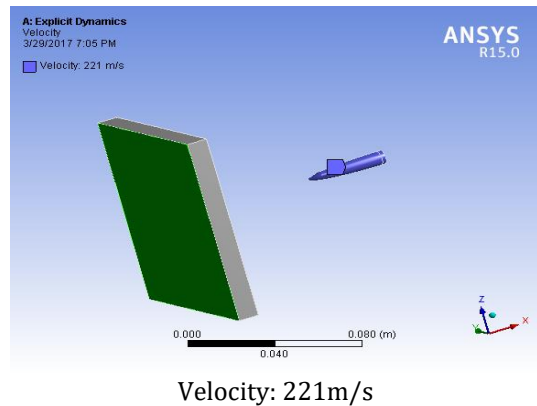
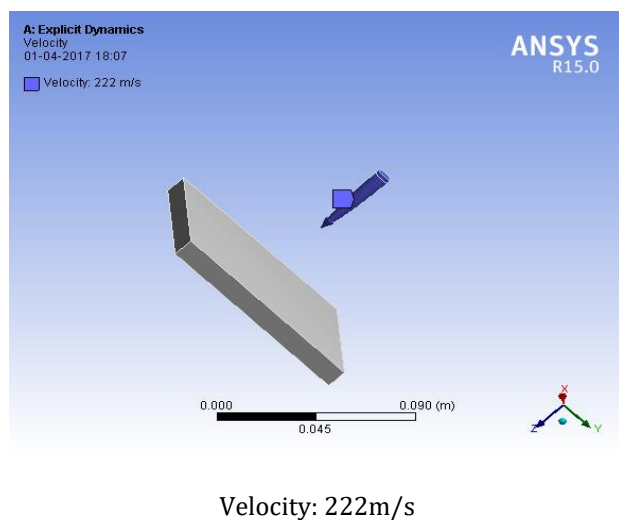
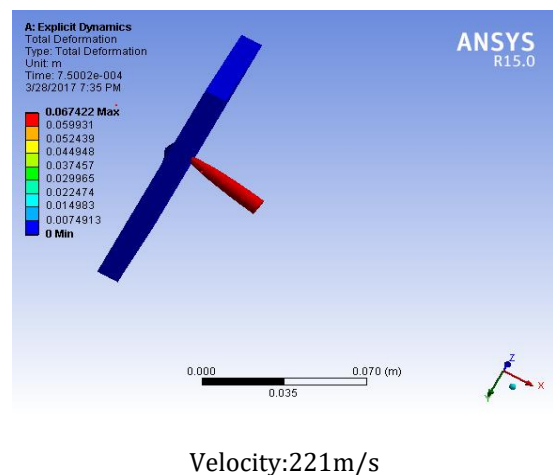
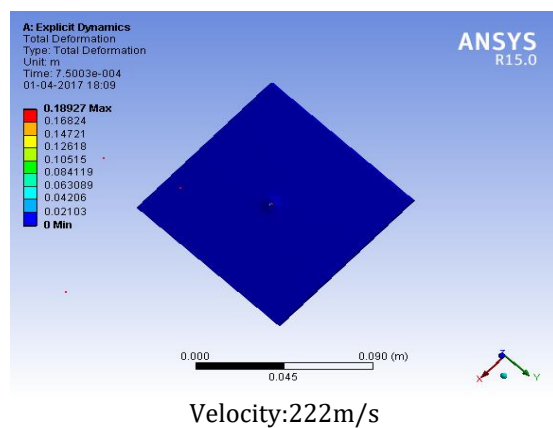
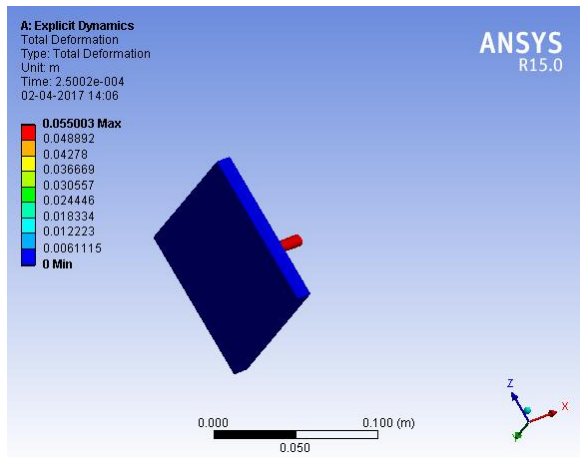

Fig.25 Different velocities

a. Total deformation





Velocity:220m/s

Fig.26 Total deformation at different velocities

The result of Figure 26 shows that maximum total deformation of plate at the bullet velocity of 222m/s is higher (0.18927m), followed by the velocity 221m/s and 220m/s which has a deformation of 0.067422m and 0.055003m respectively.

b. Equivalent Elastic Strain

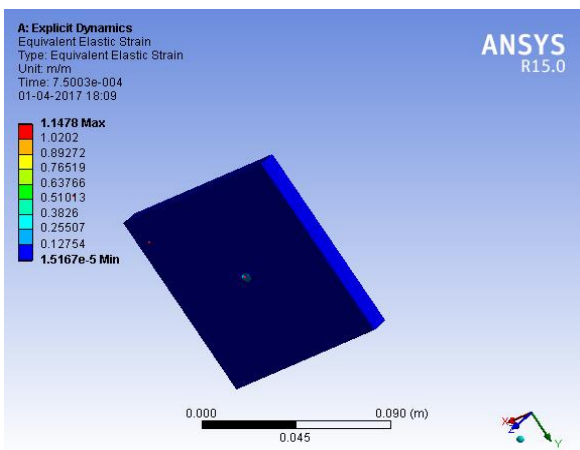

Velocity:222m/s

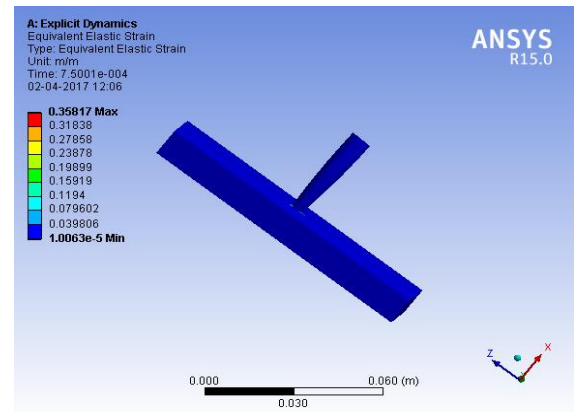

Velocity:220m/s

Fig.27 Equivalent strain at different velocity

The result of the Figure 27 shows that equivalent elastic strain of plate at the bullet velocity of 222m/s is higher (1.1478), followed by the velocity 221m/s and 220m/s which has a deformation of 0.81092 and 0.35817 respectively.

c. Equivalent Elastic stress

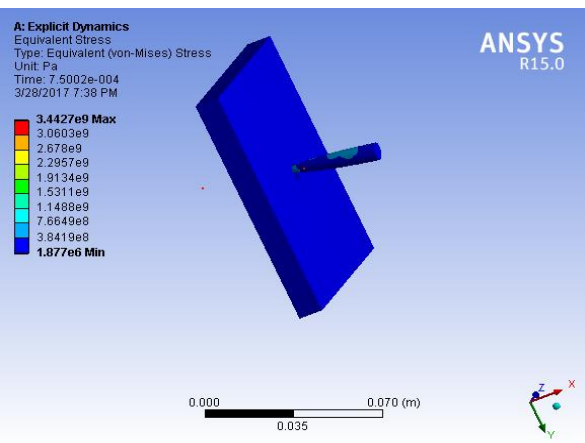

Velocity:222m/s

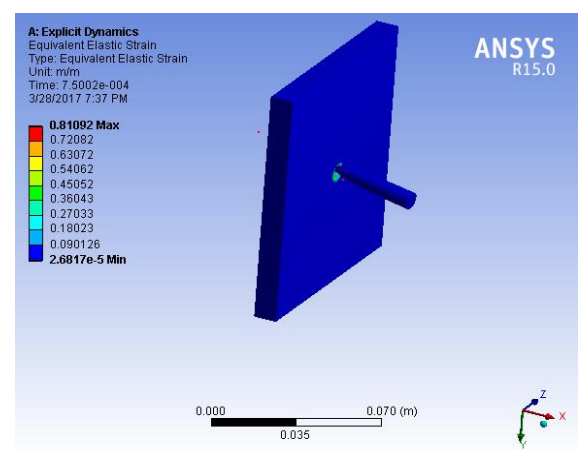

Velocity:221m/s

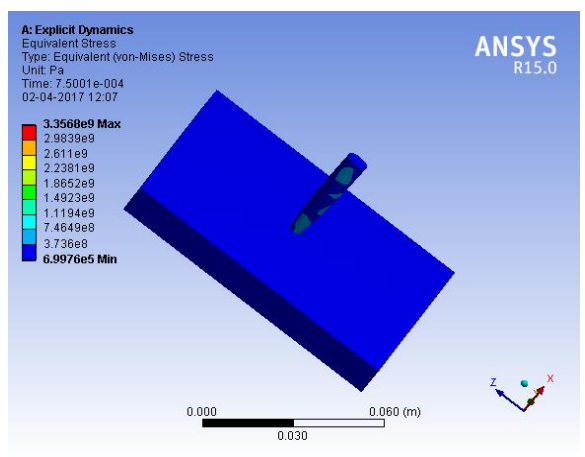

Velocity:221m/s

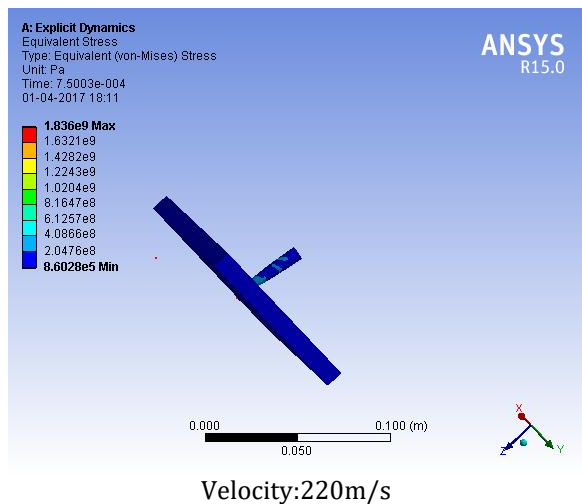

Fig.28 Equivalent Stress at different velocity

The result of the Figure 28 shows that equivalent elastic stress of plate at the bullet velocity of 222m/s is higher (3.4427×10^9 Pa), followed by the velocity 221m/s and 220m/s which has a deformation of 3.3568×10^9 Pa and 1.836×10^9 Pa respectively.

Conclusions

An analytical study has been conducted in order to identify the better ballistic limit velocity of different materials with different structures. In the first three cases the single layer plate with the materials like Al 7075-T6, Al 5083H116, Titanium were analyzed and the ballistic limit velocities of 310, 221, 364m/s resulted. Even though the titanium has higher ballistic limit velocity it is not preferred mostly, because of its higher cost and density. In the next two cases, the sandwiches structure with Kevlar 149 (without honeycomb) and Al 7075-T6 (with honeycomb) gives the ballistic limit velocity of 270, 380m/s respectively.

From this, it is observed that the sandwiches structure with honeycomb (Al 7075-T6) structure results in 22.58% more BLV value than the single layer structure made of Al 7075-T6.

References

- Sujith, N.S., Chethan, K.Y., Sandeep, M.D., Sanjay, M.S., Shaik Khader Basha, and Sowmyashree, D.S. (2015), Impact Analysis of Bullet on Different Bullet Proof Materials, *International Journal of Mechanical and Industrial Technology*, 3(1), 303-310.
- Amelie Kolopp, Samuel Rivallant, and Christophe Bouvet. (2013), Experimental study of sandwich structures as armour against medium-velocity impacts, *International Journal of Impact Engineering*, 61, 24-35.
- Artero-Guerrero, J. A., Pernas-Sanchez, J., Varas, D., and Lopez-Puente, J. (2013), Numerical analysis of CFRP fluid-filled tubes subjected to high-velocity impact, *Composite Structures*, 96, 286-297.
- J. Bernetic, B. Kosec, G. Kosec, Z. Burzic, B. Podlipec, A. Nagode, B. Karpe, S. Kanalec, F. Vodopivec, and L. Kosec. (2016), Phenomena in penetrating piercing bullets in armored steel plate, *Metalurgija*, 55 (1), 95-98.
- M. Mamivand, and G.H. Liaghat. (2010), A model for ballistic impact on multi-layer fabric targets, *International Journal of Impact Engineering*, 37, 806-812.
- Satish Ramavat, Devidas Thorat, and Prashant, C. (2012), Simulation of Bullet Impact on Bullet Resistant Steel Plate, Simulation driven innovation, *Godrej & Boyce Mfg. Co.Ltd*, 1-13.
- Jung Seop Lim. (2013), Ballistic Behavior of Heracron®-Based Composites: Effect of the Number Multifilaments on High-Speed Projectiles, *Modeling and Numerical Simulation of Material Science*, 3, 84-89.
- Vaibhav Dangwal, and Saurabh Gairola, (2014), Ballistic Simulation of Bullet Impact on a Windscreen Made of Floatglass and Plexiglass Sheets, *International Journal of Aerospace and Mechanical Engineering*, 1(1), 53-57.