



## O-Ring Design Guide

## Introduction

In 1990, Hi-Tech Seals was founded in Edmonton, Alberta. Since then, our company expanded to six locations across Canada and one location in the United States.

We are an industrial seal, gasket, rubber and plastic component distributor and manufacturer. We focus on providing superior value to our customers. We continually invest in new and innovative products, services, and equipment with the intention of helping our customers grow and prosper in an ever-changing world economy.

We offer a personal solution to the business world, tailoring our business relationship to reflect the needs of our clients. We work alongside a variety of industries, while maintaining a high-quality standard in all our products. Our diverse supply chain allows our customers to be confident we will provide a solution that exceeds their needs.

## Seal Kits

Hi-Tech Seals kit creation program provides customers with an easy to use reordering system for various types of seal kits. Whether its for maintenance or manufactured equipment our sales staff will identify the sealing components and create a kit in our system. The kit can include custom labels with company name and logos, part numbers, and application information. When placing an order, simply provide us with the kit number and receive the parts in one bag.

## ISO 9001 Registered QMS

We are committed to our Quality Management System (QMS). Hi-Tech Seals registered our first branch under an ISO QMS in 1996. Now, all our locations and divisions are registered under the ISO QMS. The four main goals of our policy include:

- Hi-Tech Seals shall distribute and/or manufacture a quality product that will meet our customers' requirements and expectations.
- Hi-Tech Seals shall strive to continually improve the effectiveness of the Quality Management System.
- Hi-Tech Seals' Quality Policy shall be communicated and understood at all levels of the organization.
- Hi-Tech Seals' Quality Policy and Quality Objectives will be reviewed for effectiveness and accuracy during the Annual Management Review.

## After Hours Service

We have a sales representative available 24 hours a day, 7 days a week. An after-hours sales representative can be reached by contacting your local branch.



Prefix	Material	Duro.	Temperature Range	Description
N70	Nitrile	70 ± 5	-40°C to 120°C -40°F to 248°F	A general service nitrile compound for a wide range of applications including petroleum based fluids. Nitrile compounds also have excellent resistance to compression set, tear and abrasion resistance.
N90	Nitrile	90 ± 5	-40°C to 120°C -40°F to 248°F	Generally used for higher pressures than the 70 durometer materials, while having comparable media resistance.
LTN	Nitrile	70 ± 5	-54°C to 120°C -65°F to 248°F	A low temperature nitrile compound for use in applications where sealability at lower temperatures is important. Due to the lower acrylonitrile content, this compound will show slightly less resistance to petroleum products.
HS7	Hydrogenated Nitrile	70 ± 5	-40°C to 160°C -40°F to 320°F	Hydrogenated nitrile provides an improved resistance to heat, ozone and aging. Similar applications to nitrile but with improved mechanical properties and media resistance. Excellent for many oilfield and automotive applications. H2S resistance up to 10%.
HS8	Hydrogenated Nitrile	80 ± 5	-40°C to 160°C -40°F to 320°F	Generally used for higher pressures than the 70 durometer materials while having comparable media resistance.
HS9	Hydrogenated Nitrile	90 ± 5	-40°C to 160°C -40°F to 320°F	Generally used for higher pressures than the 80 durometer materials while having comparable media resistance. Improved ED resistance.
V75	Viton™	75 ± 5	-26°C to 204°C -15°F to 400°F	Viton™ compounds have excellent resistance to ozone, weather, oxygen, mineral oil, fuels, hydraulic fluids, aromatics, petroleum fluids, many organic solvents and chemicals. Viton™ is also used in high temperature applications. Viton™ Extreme™ ETP compounds is also available. ETP- Provides the excellent thermal resistance of Viton™ along with significantly advanced chemical resistance.
V90	Viton™	90 ± 5	-26°C to 204°C -15°F to 400°F	Viton™ is generally used for higher pressure than the 75 durometer materials while having comparable media resistance.
LTV	Viton™ GLT	75 ± 5	-40°C to 204°C -40°F to 400°F	Viton™ GLT is used for lower temperature applications than the 75 durometer materials while having comparable media resistance.
PF7	Perfluoroelastomer	75 ± 5	-15°C to 310°C 5°F to 590°F	Perfluoroelastomer materials have the best heat and chemical resistance performance compared to other elastomer materials.
PF9	Perfluoroelastomer	90 ± 5	-15°C to 310°C 5°F to 590°F	Generally used for higher pressures than the 75 durometer materials while having comparable media resistance.
A80	Aflas® FEPM	80 ± 5	-9 °C to 232°C 16°F to 450°F	Tetrafluoroethylene-Propylene materials exhibit exceptional thermal and chemical resistance including hot water, steam, acids, alkaline solutions, ammonia, amines, brake fluids, petroleum fluids and sour gas. Low temperature may restrict sealing abilities.
NEO	Neoprene	70 ± 5	-40°C to 121°C -40°F to 250°F	Neoprene is a general purpose material for refrigerants, ozone and weather.
E70	Ethylene- Propylene	70 ± 5	-54°C to 150°C -65°F to 302°F	Ethylene-Propylene materials exhibit excellent resistance to water, steam, brake fluids and ozone.
E80	Ethylene- Propylene	80 ± 5	-54°C to 150°C -65°F to 302°F	Generally used for higher pressures than 70 durometer EPDM compounds while having comparable media resistance.
S70	Silicone	70 ± 5	-65°C to 232°C -85°F to 446°F	Silicone compounds offer the widest elastomer temperature range but typically cannot be used in dynamic applications or petroleum based fluids.
FS7	Fluorosilicone	70 ± 5	-56°C to 204°C -69°F to 400°F	Fluorosilicone has improved chemical resistance over silicone including oils, greases, & steam
TEV	PTFE Encapsulated Viton™		-60°C to 205°C -76°F to 401°F	
TES	PTFE Encapsulated Silicone		-60°C to 205°C -76°F to 401°F	

F.D.A., NSF and UL listed or approved materials available upon request. We also offer a complete range of coloured or internally lubed compounds as required. Some materials are available in durometers that range from 40 to 95 shore A. Most compounds available in metric sizing. Hi-Tech Seals Inc. also offers a complete range of back-up rings, anti-extrusion devices as well as X-rings and square cut rings. These products are available in a variety of sizes and materials, please contact your sales office for more information.

## O-Ring Cross-Section

The I.D. and O.D. of an O-ring gland is primarily influenced by diameter of the mating surface of the rod or piston and bore. Although the cross-section of the O-ring is seen as fairly arbitrary, there are some distinct advantages to either a larger or smaller cross-section O-ring. Listed below are the advantages of small cross-sections and the advantages of large cross-sections:

### Advantages of Smaller Cross-Section

- More compact
- Lighter weight
- Less expensive; especially for higher cost elastomers like FKM or fluorosilicone
- Less machining required for machined grooves since grooves are smaller
- Increased resistant to explosive decompression

### Advantages of Larger Cross-Section

- Less prone to compression set
- Less volume swell in liquid on a percentage basis
- Allows for larger tolerance while still maintaining acceptable compression squeeze and compression ratio over full stack-up range
- Less prone to leakage due to contamination; dirt, lint, scratches, etc.

## O-Ring Gland Types

O-rings are primarily used to prevent the loss of a fluid or gas. However, O-rings can be used as dust seals, drive belts or on rotating shafts. Most O-ring seals can be classified into one of the three arrangements shown below.

Piston Configuration

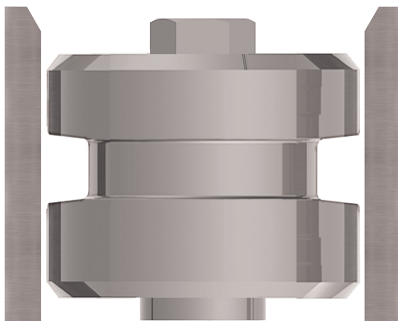

Rod Configuration

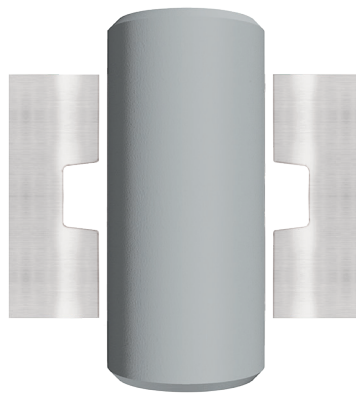

Face Type Configuration

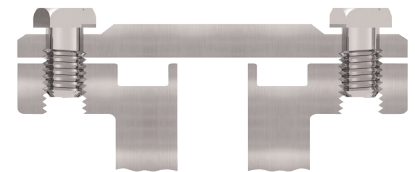

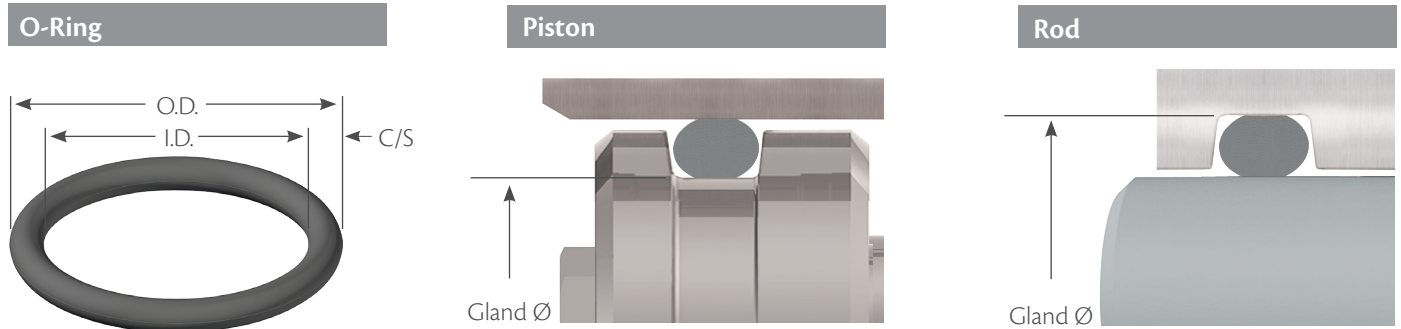

## I.D. Stretch/O.D. Interference

### *For hydraulic and pneumatic piston sealing applications*

The O-ring I.D. should be stretched between 2% and 5% for dynamic applications and 2% and 8% for static applications. For O-rings with an I.D. smaller than 20 mm, this is not always possible which can result in a wider range of stretch. To minimize this range and the maximum stretch, it is necessary to minimize the tolerance of the piston gland diameter, and have a less stringent requirement for the minimum O-ring stretch. In dynamic applications, it is important to keep the maximum stretch to 5% or less to avoid detrimental effects on sealing performance.

### *For hydraulic and pneumatic rod sealing applications*

The O-ring O.D. should be equal to or larger than the rod gland diameter to give interference on the O-ring O.D. The O-ring O.D. should not exceed 3% of the rod gland diameter for O-rings with an I.D. greater than 250 mm, or 5% for O-rings with an I.D. smaller than 250 mm. For O-rings with an I.D. smaller than 20 mm, this is not always possible due to tolerance issues, which can result in a greater O-ring O.D. interference.

## O-Ring Selection

### Reduction in Cross-Section

If the I.D. of the O-ring is stretched, the cross-section of the O-ring will decrease. The following table gives the O-ring cross-sections that result from various percentages of I.D. stretch.

O-Ring Series	Original O-Ring C/S		Reduced O-Ring C/S at % ID Stretch (Inch/mm)				
	Inch	mm	1%	2%	3%	4%	5%
000	0.070	1.78	0.069/1.76	0.069/1.74	0.068/1.73	0.068/1.71	0.068/1.69
100	0.103	2.62	0.102/2.59	0.101/2.57	0.100/2.54	0.100/2.52	0.100/2.49
200	0.139	3.53	0.138/3.49	0.137/3.46	0.136/3.42	0.135/3.39	0.134/3.35
300	0.210	5.33	0.208/5.28	0.206/5.22	0.205/5.17	0.204/5.12	0.203/5.06
400	0.275	6.99	0.272/6.92	0.270/6.85	0.268/6.78	0.267/6.71	0.266/6.64

### Compression

Compression squeeze is the difference between the original O-ring cross-section and the final O-ring cross-section once installed.



This can usually be expressed as a percentage: 
$$\text{O-ring C/S Squeeze (\%)} = \frac{\text{Compression Squeeze}}{\text{C/S}} \times 100$$

For recommended O-ring C/S squeeze (%) values please refer to page 11-12.

## Gland Fill

The gland fill is the percentage of the gland that is occupied by the O-ring. It is calculated by dividing the cross-sectional area (CSA) of the O-ring by the cross-sectional area of the gland.

$$\text{Area of a circle} = \pi r^2 \text{ and } r = \frac{d}{2}, \text{ where } d = \text{diameter (C/S)}$$

$$\text{Therefore, O-ring CSA} = \pi \left( \frac{C/S}{2} \right)^2$$

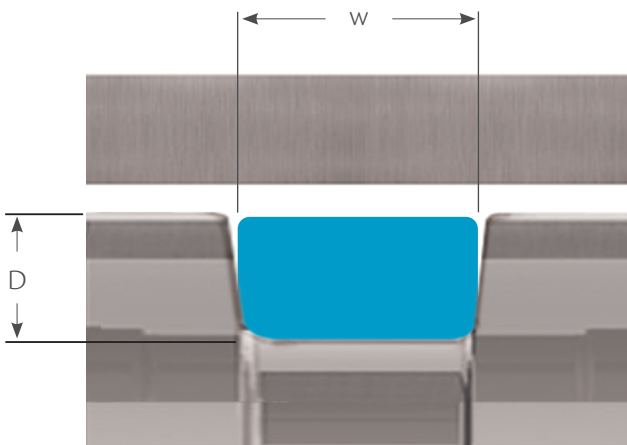

*w- groove width, D- groove depth*

$$\text{Gland CSA} = D \times w^*$$

$$\text{Gland Fill (\%)} = \frac{\text{O-ring CSA}}{\text{Gland CSA}} \times 100$$

*\* Effect of gland angle and extrusion gap not addressed.*

It is important to consider the groove fill or occupancy of the installed O-ring to avoid detrimental effects on radial sealing performance. Groove fill of the installed O-ring should not exceed 85 % to allow for possible O-ring thermal expansion, volume swell due to fluid exposure and effects of tolerances.

Volume change is the increase or decrease of the volume of an elastomer after it has been in contact with a fluid, measured in percent (%). For static O-ring applications volume swell up to 30 % can usually be tolerated. For dynamic applications, 10 or 15 % swell is a reasonable maximum unless special provisions are made in the gland design itself. This is a general rule and there may occasionally be exceptions.

It is also important to note there are significant differences in the coefficients of thermal expansion between the O-ring material and the groove materials. Elastomers can have coefficients of thermal expansion 7 to 20 times higher than that of metal, such as steel.

## Extrusion Gap

Extrusion is a concern for radial seals where there is gap between the piston and the bore for a piston type seal or between the rod and the bore for a rod type seal. It is not typically a concern for face type seals where the metal parts to be sealed are in contact line-to-line. The issue is that at higher pressures and especially for softer O-ring elastomers, the O-ring can be forced by the pressure into the small gap between the piston (or rod) and the bore. Unless the bore and the piston (or rod) are ensured to remain concentric by the hardware, we have to assume that entire possible gap can shift to one side (see diagram below).

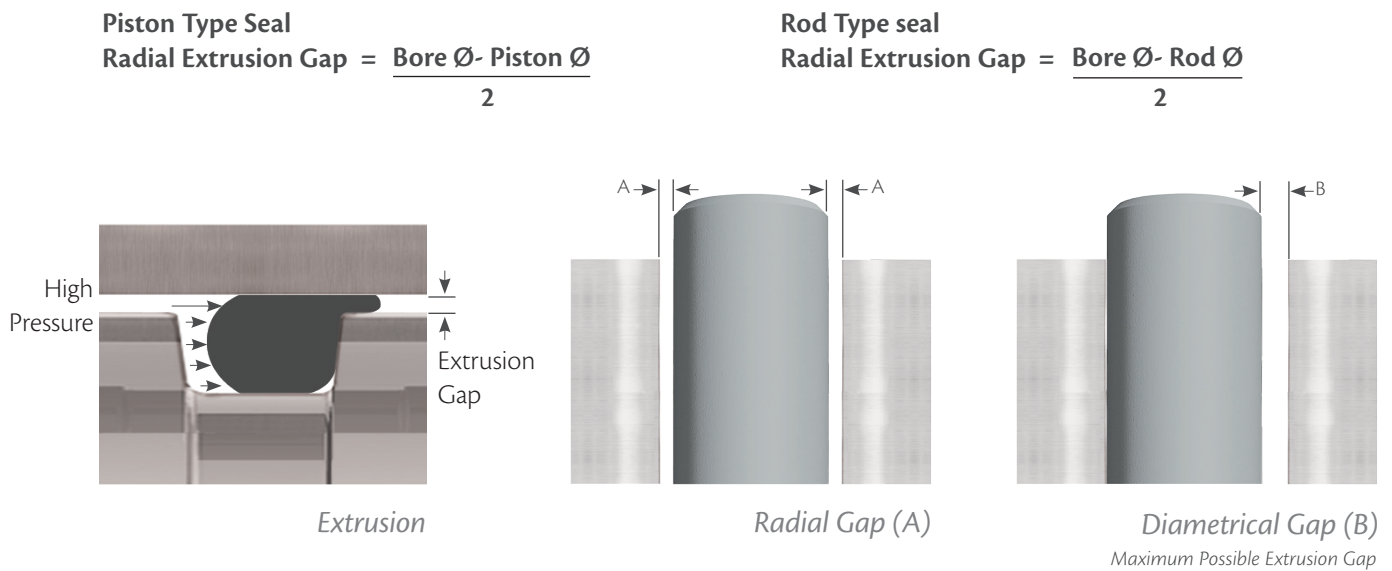

## Limits for Extrusion

There are different methods to counter O-ring extrusion. One of these methods is to increase the durometer rating of the O-ring. However, as the durometer is increased, the O-ring can become less malleable. Another option would be the use of anti-extrusion devices. These are thin rings made of hard plastic materials such as PTFE, nylon, and PEEK. Once in place these rings will provide essentially zero clearance.

*Reduce the clearance shown by 60% when using silicone or fluoro-silicone elastomers.*

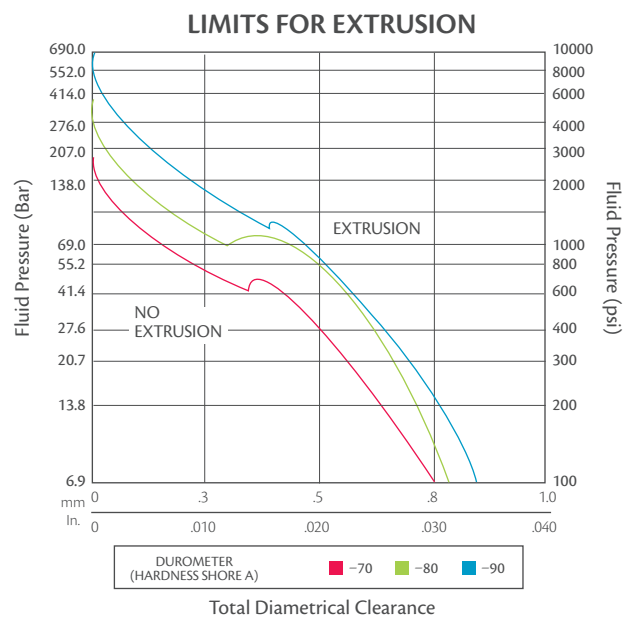



## Groove Dimensions - ISO 3601

### Static Radial Applications

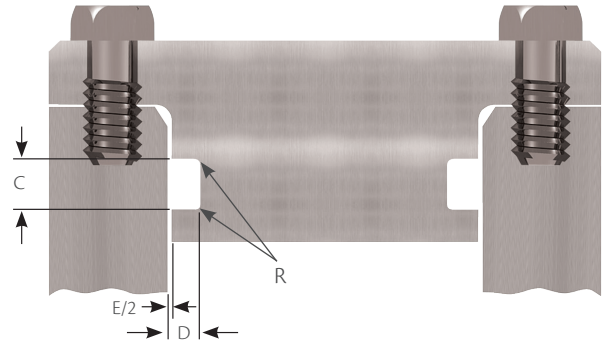

*Pneumatic applications typically do not use a back-up ring. Information is based on ISO 3601*

O-Ring C/S	D Groove Depth	Squeeze		E Diametrical Clearance Max.	C Groove Width +0.010/-0.000			R Groove Radius
		Inches	%		No Back- Up Ring	One Back- Up Ring	Two Back- Up Rings	
0.070	0.049 - 0.057	0.010 - 0.025	14 - 35	0.004	0.110	0.165	0.220	0.008 - 0.016
0.103	0.075 - 0.087	0.013 - 0.031	13 - 30	0.005	0.150	0.205	0.260	0.008 - 0.016
0.139	0.101 - 0.117	0.018 - 0.042	13 - 30	0.006	0.197	0.252	0.307	0.016 - 0.031
0.210	0.156 - 0.180	0.025 - 0.059	12 - 28	0.006	0.283	0.354	0.429	0.016 - 0.031
0.275	0.212 - 0.242	0.028 - 0.069	10 - 25	0.007	0.374	0.484	0.594	0.031 - 0.047

### Static Axial (Face) Applications

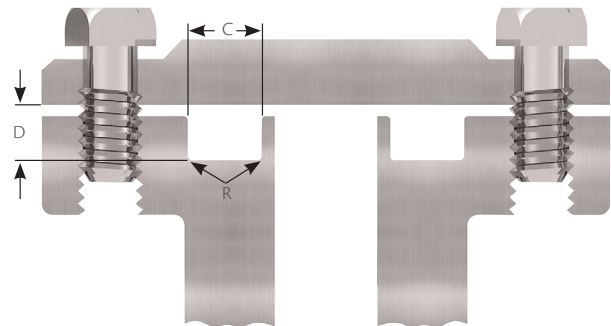

*Information is based on ISO 3601*

O-Ring C/S	D Groove Depth +0.004/-0.000	Squeeze %	C Groove Width +0.008/-0.000		R Groove Radius
			Hydraulic	Pneumatic/Vacuum	
0.070	0.051	21 - 36	0.126	0.114	0.008 - 0.016
0.103	0.079	19 - 30	0.157	0.142	0.008 - 0.016
0.139	0.106	17 - 26	0.209	0.189	0.016 - 0.031
0.210	0.165	15 - 23	0.299	0.276	0.016 - 0.031
0.275	0.224	13 - 20	0.354	0.335	0.031 - 0.047

Imperial

## Reciprocating Applications

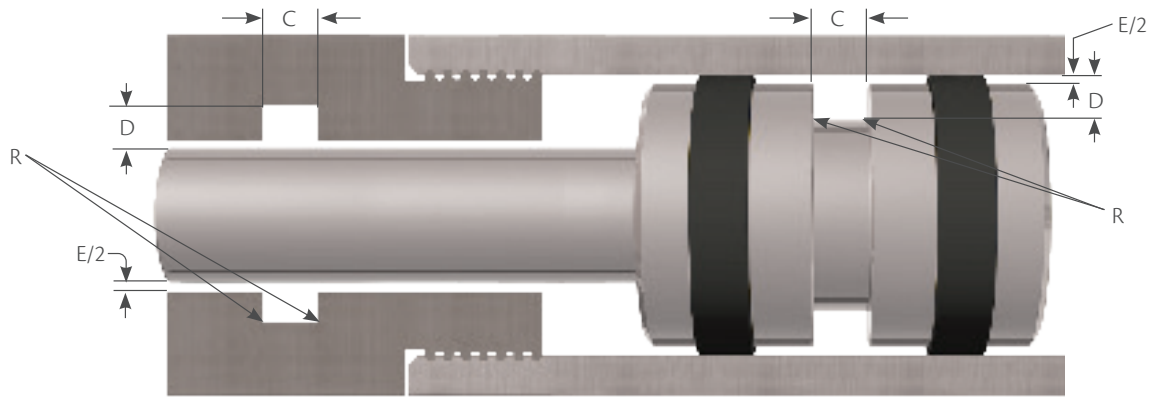

Information is based on ISO 3601

\* Pneumatic applications typically do not use a back-up ring.

O-Ring C/S	D		Squeeze				E	C			R
	Groove depth		Hydraulic		Pneumatic			Groove Width +0.010/-0.000			
	Hydraulic	Pneumatic	Inches	%	Inches	%		No Back- Up Ring	One Back- Up Ring	Two Back- Up Rings	
0.070	0.054 - 0.058	0.056 - 0.060	0.009 - 0.019	13 - 27	0.007 - 0.017	10 - 24	0.004	0.110	0.165	0.220	0.008 - 0.016
0.103	0.081 - 0.088	0.083 - 0.092	0.012 - 0.025	12 - 24	0.008 - 0.023	8 - 22	0.005	0.150	0.205	0.260	0.008 - 0.016
0.139	0.112 - 0.120	0.115 - 0.125	0.015 - 0.031	11 - 22	0.010 - 0.028	7 - 20	0.006	0.197	0.252	0.307	0.016 - 0.031
0.210	0.173 - 0.182	0.177 - 0.190	0.023 - 0.042	11 - 20	0.015 - 0.038	7 - 18	0.006	0.283	0.354	0.429	0.016 - 0.031
0.275	0.229 - 0.244	0.234 - 0.253	0.025 - 0.052	9 - 19	0.017 - 0.047	6 - 17	0.007	0.374	0.484	0.594	0.031 - 0.047

Note: For piston applications groove width (w) values do not apply for 001-003 and 400-424 series O-rings. For rod applications groove width (w) values do not apply for 001-003, 028-050, 135-178, 232-284, 350-395, 400-424 and 430-475.

Metric

## Groove Details

### Piston & Rod Applications

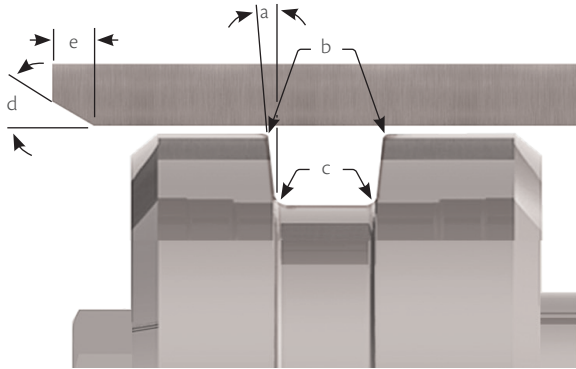

Piston Application

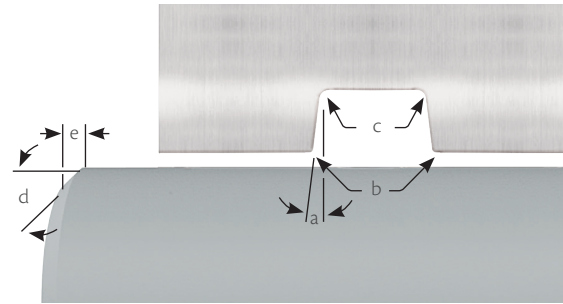

Rod Application

O-Ring Series	O-Ring C/S		Wall Angle a	Break Edge b	Radius c		Chamfer Length (e)			
	Inch	mm			Inch	mm	d at 15°		d at 20°	
							Inch	mm	Inch	mm
0	0.070	1.78	0-5°	0.004 - 0.012 Inch 0.10 - 0.30 mm	0.008 - 0.016	0.20 - 0.40	0.043	1.10	0.035	0.90
100	0.103	2.62			0.008 - 0.016	0.20 - 0.40	0.059	1.50	0.043	1.10
200	0.139	3.53			0.016 - 0.031	0.40 - 0.80	0.071	1.80	0.055	1.40
300	0.210	5.33			0.016 - 0.031	0.40 - 0.80	0.106	2.70	0.083	2.10
400	0.275	6.99			0.031 - 0.047	0.80 - 1.20	0.142	3.60	0.110	2.80

## Surface Finish

The surface roughness of the O-ring gland and any mating part has a significant impact on the life and sealing performance of the O-ring. The following are general fluid sealing surface roughness values in microinches (μinch):

**For a static mating surface: Ra 16-32 μinch**

**For a dynamic mating surface: Ra 8-16 μinch**

Metric

## Tolerances for Non-Standard O-Rings

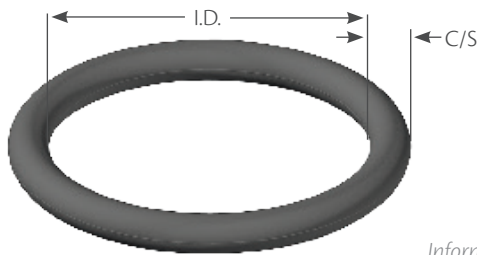

Information based on ISO 3601 Non-Standard Class A O-Rings.

Cross Section (C/S)	Tolerance mm
0.80 < C/S ≤ 3.15	± 0.08
3.15 < C/S ≤ 4.50	± 0.10
4.50 < C/S ≤ 6.30	± 0.13
6.30 < C/S ≤ 8.40	± 0.15
*9.00 ≤ C/S ≤ 20.00	± 0.20

\*Based on DIN 3771.

Machining information and tolerances for various standards are available through Hi-Tech Seals.

Information provided in this catalogue is meant to aid with seal selection process. Contact us for assistance in designing an application.

Inside Diameter (I.D) mm		Tolerance mm
0.68	to 1.53	± 0.10
1.54	to 11.69	± 0.13
11.70	to 13.46	± 0.15
13.47	to 17.53	± 0.18
17.54	to 20.57	± 0.20
20.58	to 23.88	± 0.23
23.89	to 28.70	± 0.25
28.71	to 35.56	± 0.30
35.57	to 43.18	± 0.36
43.19	to 50.80	± 0.41
50.81	to 58.42	± 0.46
58.43	to 66.55	± 0.51
66.56	to 74.93	± 0.56
74.94	to 83.57	± 0.61
83.58	to 92.20	± 0.66
92.21	to 101.60	± 0.71
101.61	to 117.35	± 0.76
117.36	to 141.22	± 0.89
141.23	to 166.37	± 1.02
166.38	to 192.02	± 1.14
192.03	to 218.69	± 1.27
218.70	to 253.37	± 1.40
253.38	to 289.56	± 1.52
289.57	to 347.98	± 1.78
347.99	to 408.94	± 2.03
408.95	to 472.44	± 2.29
472.45	to 571.50	± 2.54
571.51	to 711.20	± 3.05
711.21	to 855.98	± 3.56
855.99	to 1005.84	± 4.06
1005.85	to 1163.32	± 4.57
1163.33	to 1320.80	± 5.08

## Groove Dimensions - Din. 3771

### Static Radial Applications

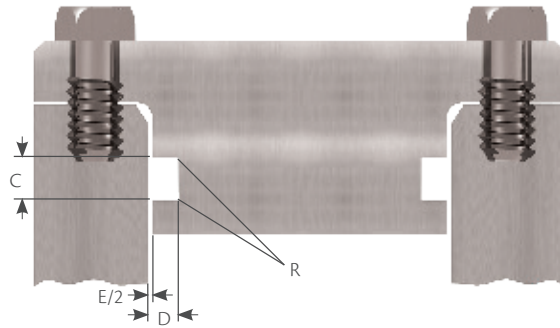

Information is based on DIN. 3771.

O-ring C/S	±	D Gland Depth	±	E Diametrical Clearance	C Groove Width +0.13/-0.00	R Groove Radius	Max. Eccentricity
1.00	0.08	0.72	0.02	0.10	1.35	0.2	0.05
1.20	0.08	0.87	0.02	0.10	1.60	0.2	0.05
1.50	0.08	1.09	0.02	0.10	2.00	0.2	0.05
1.60	0.08	1.16	0.03	0.10	2.10	0.2	0.05
1.78 - 1.80	0.08	1.29	0.03	0.10	2.35	0.2	0.05
1.90	0.08	1.38	0.03	0.10	2.50	0.2	0.05
2.00	0.08	1.45	0.04	0.10	2.65	0.2	0.05
2.40	0.08	1.90	0.04	0.10	3.25	0.2	0.05
2.50	0.08	1.98	0.04	0.10	3.40	0.2	0.05
2.62	0.08	2.07	0.04	0.10	3.55	0.2	0.05
3.00	0.08	2.40	0.04	0.15	4.05	0.5	0.07
3.50 - 3.53	0.10	2.82	0.05	0.15	4.75	0.5	0.07
3.60	0.10	2.88	0.05	0.15	4.85	0.5	0.07
4.00	0.10	3.20	0.06	0.15	5.40	0.5	0.07
4.50	0.10	3.64	0.06	0.15	6.00	0.5	0.07
5.00	0.13	4.04	0.06	0.15	6.70	0.7	0.10
5.33- 5.34	0.13	4.31	0.08	0.15	7.15	0.7	0.10
5.50	0.13	4.45	0.08	0.15	7.35	0.7	0.10
5.70	0.13	4.61	0.08	0.15	7.65	0.7	0.10
6.00	0.13	4.91	0.08	0.18	8.15	0.7	0.13
6.99	0.15	5.72	0.10	0.18	9.50	0.7	0.13
7.00	0.15	5.73	0.10	0.18	9.55	0.7	0.13
7.50	0.15	6.14	0.10	0.18	10.20	1.0	0.13
8.00	0.18	6.55	0.10	0.18	10.90	1.0	0.13
8.40	0.18	6.87	0.15	0.18	11.45	1.0	0.13
9.00	0.2	7.65	0.15	0.18	11.85	1.0	0.13
10.0	0.2	8.50	0.15	0.18	13.20	1.0	0.13
11.0	0.2	9.35	0.15	0.18	14.50	1.0	0.13
12.0	0.2	10.20	0.15	0.18	15.85	1.5	0.13
13.0	0.2	11.05	0.15	0.18	17.15	1.5	0.13
14.0	0.2	11.90	0.3	0.18	18.45	1.5	0.13
16.0	0.2	13.60	0.3	0.18	21.10	1.5	0.13
18.0	0.2	15.30	0.3	0.18	23.75	1.5	0.13
20.0	0.2	17.00	0.3	0.18	26.40	1.5	0.13

Groove Dimensions - Din. 3771  
Metric

## Static Axial (Face) Applications

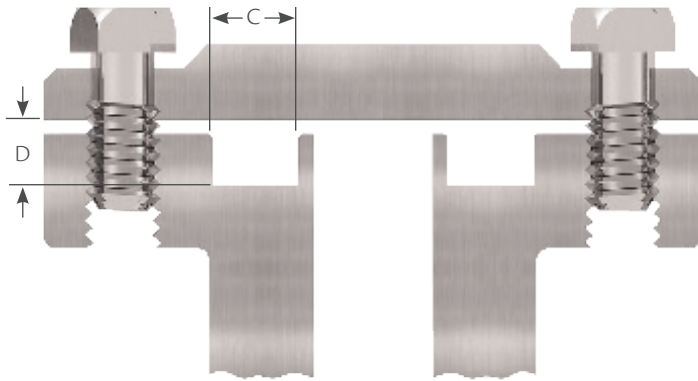

Information is based on DIN. 3771.

O-Ring C/S	±	D		C Groove Width	
		Gland Depth	±	Hydraulic +0.13/-0.00	Pneumatic ± 0.13
1.00	0.08	0.75	0.02	1.45	1.20
1.20	0.08	0.90	0.02	1.75	1.45
1.50	0.08	1.13	0.02	2.20	1.80
1.60	0.08	1.20	0.03	2.35	1.90
1.78 - 1.80	0.08	1.34	0.03	2.60	2.15
1.90	0.08	1.43	0.03	2.75	2.30
2.00	0.08	1.51	0.04	2.90	2.40
2.40	0.08	1.82	0.04	3.20	2.80
2.50	0.08	1.90	0.04	3.30	2.90
2.62	0.08	1.99	0.04	3.50	3.05
3.00	0.08	2.27	0.04	3.90	3.45
3.50 - 3.53	0.10	2.67	0.05	4.60	4.05
3.60	0.10	2.72	0.05	4.70	4.10
4.00	0.10	3.03	0.06	5.25	4.60
4.50	0.10	3.60	0.06	6.10	5.10
5.00	0.13	4.00	0.06	6.80	5.70
5.33	0.13	4.26	0.08	7.25	6.05
5.50	0.13	4.40	0.08	7.45	6.25
5.70	0.13	4.56	0.08	7.75	6.50
6.00	0.13	4.98	0.08	8.00	6.75
6.99	0.15	5.80	0.10	9.05	7.85
7.00	0.15	5.81	0.10	9.05	7.90
7.50	0.15	6.23	0.10	9.70	8.40
8.00	0.15	6.64	0.10	10.35	9.00
8.40	0.15	6.97	0.15	10.90	9.45

## Reciprocating Applications

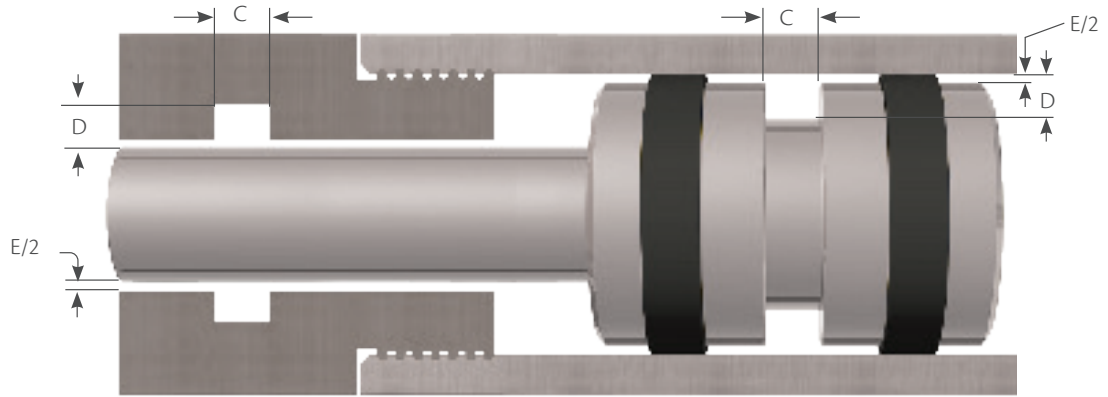

Information is based on DIN. 3771.

O-Ring C/S	±	D Gland Depth	±	E Diametrical Clearance	C Groove Width +0.13/-0.00	Max. Eccentricity
1.00	0.08	0.80	0.02	0.10	1.35	0.05
1.20	0.08	0.96	0.02	0.10	1.60	0.05
1.50	0.08	1.20	0.02	0.10	2.00	0.05
1.60	0.08	1.28	0.03	0.10	2.10	0.05
1.78 - 1.80	0.08	1.42	0.03	0.10	2.40	0.05
1.90	0.08	1.52	0.03	0.10	2.50	0.05
2.00	0.08	1.60	0.04	0.10	2.65	0.05
2.40	0.08	2.06	0.04	0.10	3.25	0.05
2.50	0.08	2.15	0.04	0.10	3.40	0.05
2.62	0.08	2.25	0.04	0.10	3.55	0.05
3.00	0.08	2.61	0.04	0.15	4.05	0.07
3.50 - 3.53	0.10	3.07	0.05	0.15	4.75	0.07
3.60	0.10	3.13	0.05	0.15	4.85	0.07
4.00	0.10	3.48	0.05	0.15	5.40	0.07
4.50	0.10	3.99	0.05	0.15	6.00	0.07
5.00	0.13	4.44	0.05	0.15	6.70	0.10
5.33- 5.34	0.13	4.73	0.05	0.15	7.15	0.10
5.50	0.13	4.88	0.05	0.15	7.40	0.10
5.70	0.13	5.06	0.05	0.15	7.60	0.10
6.00	0.13	5.19	0.05	0.18	8.15	0.13
6.99	0.15	6.05	0.05	0.18	9.50	0.13
7.00	0.15	6.06	0.05	0.18	9.55	0.13
7.50	0.15	6.49	0.05	0.18	10.20	0.13
8.00	0.18	6.92	0.05	0.18	10.90	0.13
8.40	0.18	7.27	0.05	0.18	11.45	0.13
9.00	0.20	7.92	0.05	0.18	12.10	0.13
10.00	0.20	8.80	0.05	0.18	13.40	0.13

# O-Ring Sizing Charts

## Imperial O-Ring Sizes

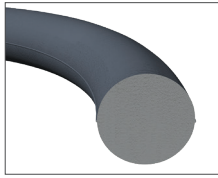

Square Cut Ring	Actual C/S
000 Series	0.066
100 Series	0.099
200 Series	0.134
300 Series	0.205
400 Series	0.266

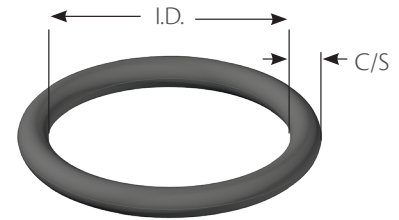

Dash #	Nominal			Actual Sizing				Metric Actual			
	I.D.	O.D.	C/S	I.D.		C/S		I.D.		C/S	
001	1/32	3/32	1/32	0.029	± 0.004	0.040	± 0.003	0.74	± 0.10	1.02	± 0.08
002	3/64	9/64	3/64	0.042	± 0.004	0.050	± 0.003	1.07	± 0.10	1.27	± 0.08
003	1/16	3/16	1/16	0.056	± 0.004	0.060	± 0.003	1.42	± 0.10	1.52	± 0.08
004	5/64	13/64	1/16	0.070	± 0.005	0.070	± 0.003	1.78	± 0.13	1.78	± 0.08
005	3/32	7/32	1/16	0.101	± 0.005	0.070	± 0.003	2.57	± 0.13	1.78	± 0.08
006	1/8	1/4	1/16	0.114	± 0.005	0.070	± 0.003	2.90	± 0.13	1.78	± 0.08
007	5/32	9/32	1/16	0.145	± 0.005	0.070	± 0.003	3.68	± 0.13	1.78	± 0.08
008	3/16	5/16	1/16	0.176	± 0.005	0.070	± 0.003	4.47	± 0.13	1.78	± 0.08
009	7/32	11/32	1/16	0.208	± 0.005	0.070	± 0.003	5.28	± 0.13	1.78	± 0.08
010	1/4	3/8	1/16	0.239	± 0.005	0.070	± 0.003	6.07	± 0.13	1.78	± 0.08
011	5/16	7/16	1/16	0.301	± 0.005	0.070	± 0.003	7.65	± 0.13	1.78	± 0.08
012	3/8	1/2	1/16	0.364	± 0.005	0.070	± 0.003	9.25	± 0.13	1.78	± 0.08
013	7/16	9/16	1/16	0.426	± 0.005	0.070	± 0.003	10.82	± 0.13	1.78	± 0.08
014	1/2	5/8	1/16	0.489	± 0.005	0.070	± 0.003	12.42	± 0.13	1.78	± 0.08
015	9/16	11/16	1/16	0.551	± 0.007	0.070	± 0.003	14.00	± 0.18	1.78	± 0.08
016	5/8	3/4	1/16	0.614	± 0.009	0.070	± 0.003	15.60	± 0.23	1.78	± 0.08
017	11/16	13/16	1/16	0.676	± 0.009	0.070	± 0.003	17.17	± 0.23	1.78	± 0.08
018	3/4	7/8	1/16	0.739	± 0.009	0.070	± 0.003	18.77	± 0.23	1.78	± 0.08
019	13/16	15/16	1/16	0.801	± 0.009	0.070	± 0.003	20.35	± 0.23	1.78	± 0.08
020	7/8	1	1/16	0.864	± 0.009	0.070	± 0.003	21.95	± 0.23	1.78	± 0.08
021	15/16	1 - 1/16	1/16	0.926	± 0.009	0.070	± 0.003	23.52	± 0.23	1.78	± 0.08
022	1	1 - 1/8	1/16	0.989	± 0.010	0.070	± 0.003	25.12	± 0.25	1.78	± 0.08
023	1 - 1/16	1 - 3/16	1/16	1.051	± 0.010	0.070	± 0.003	26.70	± 0.25	1.78	± 0.08
024	1 - 1/8	1 - 1/4	1/16	1.114	± 0.010	0.070	± 0.003	28.30	± 0.25	1.78	± 0.08
025	1 - 3/16	1 - 5/16	1/16	1.176	± 0.011	0.070	± 0.003	29.87	± 0.28	1.78	± 0.08
026	1 - 1/4	1 - 3/8	1/16	1.239	± 0.011	0.070	± 0.003	31.47	± 0.28	1.78	± 0.08
027	1 - 5/16	1 - 7/16	1/16	1.301	± 0.011	0.070	± 0.003	33.05	± 0.28	1.78	± 0.08
028	1 - 3/8	1 - 1/2	1/16	1.364	± 0.013	0.070	± 0.003	34.65	± 0.33	1.78	± 0.08
029	1 - 1/2	1 - 5/8	1/16	1.481	± 0.013	0.070	± 0.003	37.62	± 0.33	1.78	± 0.08
030	1 - 5/8	1 - 3/4	1/16	1.614	± 0.013	0.070	± 0.003	41.00	± 0.33	1.78	± 0.08
031	1 - 3/4	1 - 7/8	1/16	1.739	± 0.015	0.070	± 0.003	44.17	± 0.38	1.78	± 0.08
032	1 - 7/8	2	1/16	1.864	± 0.015	0.070	± 0.003	47.35	± 0.38	1.78	± 0.08
033	2	2 - 1/8	1/16	1.989	± 0.018	0.070	± 0.003	50.25	± 0.46	1.78	± 0.08
034	2 - 1/8	2 - 1/4	1/16	2.114	± 0.018	0.070	± 0.003	53.70	± 0.46	1.78	± 0.08
035	2 - 1/4	2 - 3/8	1/16	2.239	± 0.018	0.070	± 0.003	56.87	± 0.46	1.78	± 0.08
036	2 - 3/8	2 - 1/2	1/16	2.364	± 0.018	0.070	± 0.003	60.05	± 0.46	1.78	± 0.08
037	2 - 1/2	2 - 5/8	1/16	2.489	± 0.018	0.070	± 0.003	63.22	± 0.46	1.78	± 0.08
038	2 - 5/8	2 - 3/4	1/16	2.614	± 0.020	0.070	± 0.003	66.40	± 0.51	1.78	± 0.08
039	2 - 3/4	2 - 7/8	1/16	2.739	± 0.020	0.070	± 0.003	69.57	± 0.51	1.78	± 0.08
040	2 - 7/8	3	1/16	2.864	± 0.020	0.070	± 0.003	72.75	± 0.51	1.78	± 0.08
041	3	3 - 1/8	1/16	2.989	± 0.024	0.070	± 0.003	75.92	± 0.61	1.78	± 0.08
042	3 - 1/4	3 - 3/8	1/16	3.239	± 0.024	0.070	± 0.003	82.27	± 0.61	1.78	± 0.08
043	3 - 1/2	3 - 5/8	1/16	3.489	± 0.024	0.070	± 0.003	88.62	± 0.61	1.78	± 0.08



Dash #	Nominal			Imperial Actual				Metric Actual			
	I.D.	O.D.	C/S	I.D.		C/S		I.D.		C/S	
044	3 - 3/4	3 - 7/8	1/16	3.739	± 0.027	0.070	± 0.003	94.97	± 0.69	1.78	± 0.08
045	4	4 - 1/8	1/16	3.989	± 0.027	0.070	± 0.003	101.32	± 0.69	1.78	± 0.08
046	4 - 1/4	4 - 3/8	1/16	4.239	± 0.030	0.070	± 0.003	107.67	± 0.76	1.78	± 0.08
047	4 - 1/2	4 - 5/8	1/16	4.489	± 0.030	0.070	± 0.003	114.02	± 0.76	1.78	± 0.08
048	4 - 3/4	4 - 7/8	1/16	4.739	± 0.030	0.070	± 0.003	120.37	± 0.76	1.78	± 0.08
049	5	5 - 1/8	1/16	4.989	± 0.037	0.070	± 0.003	126.72	± 0.94	1.78	± 0.08
050	5 - 1/4	5 - 3/8	1/16	5.239	± 0.037	0.070	± 0.003	133.07	± 0.94	1.78	± 0.08
102	1/16	1/4	3/32	0.049	± 0.005	0.103	± 0.003	1.24	± 0.13	2.62	± 0.08
103	3/32	9/32	3/32	0.081	± 0.005	0.103	± 0.003	2.06	± 0.13	2.62	± 0.08
104	1/8	5/16	3/32	0.112	± 0.005	0.103	± 0.003	2.84	± 0.13	2.62	± 0.08
105	5/32	11/32	3/32	0.143	± 0.005	0.103	± 0.003	3.63	± 0.13	2.62	± 0.08
106	3/16	3/8	3/32	0.174	± 0.005	0.103	± 0.003	4.42	± 0.13	2.62	± 0.08
107	7/32	13/32	3/32	0.206	± 0.005	0.103	± 0.003	5.23	± 0.13	2.62	± 0.08
108	1/4	7/16	3/32	0.237	± 0.005	0.103	± 0.003	6.02	± 0.13	2.62	± 0.08
109	5/16	1/2	3/32	0.299	± 0.005	0.103	± 0.003	7.59	± 0.13	2.62	± 0.08
110	3/8	9/16	3/32	0.362	± 0.005	0.103	± 0.003	9.19	± 0.13	2.62	± 0.08
111	7/16	5/8	3/32	0.424	± 0.005	0.103	± 0.003	10.77	± 0.13	2.62	± 0.08
112	1/2	11/16	3/32	0.487	± 0.005	0.103	± 0.003	12.37	± 0.13	2.62	± 0.08
113	9/16	3/4	3/32	0.549	± 0.007	0.103	± 0.003	13.94	± 0.18	2.62	± 0.08
114	5/8	13/16	3/32	0.612	± 0.009	0.103	± 0.003	15.54	± 0.23	2.62	± 0.08
115	11/16	7/8	3/32	0.674	± 0.009	0.103	± 0.003	17.12	± 0.23	2.62	± 0.08
116	3/4	15/16	3/32	0.737	± 0.009	0.103	± 0.003	18.72	± 0.23	2.62	± 0.08
117	13/16	1	3/32	0.799	± 0.010	0.103	± 0.003	20.29	± 0.25	2.62	± 0.08
118	7/8	1 - 1/16	3/32	0.862	± 0.010	0.103	± 0.003	21.89	± 0.25	2.62	± 0.08
119	15/16	1 - 1/8	3/32	0.924	± 0.010	0.103	± 0.003	23.47	± 0.25	2.62	± 0.08
120	1	1 - 3/16	3/32	0.987	± 0.010	0.103	± 0.003	25.07	± 0.25	2.62	± 0.08
121	1 - 1/16	1 - 1/4	3/32	1.049	± 0.010	0.103	± 0.003	26.64	± 0.25	2.62	± 0.08
122	1 - 1/8	1 - 5/16	3/32	1.112	± 0.010	0.103	± 0.003	28.24	± 0.25	2.62	± 0.08
123	1 - 3/16	1 - 3/8	3/32	1.174	± 0.012	0.103	± 0.003	29.82	± 0.30	2.62	± 0.08
124	1 - 1/4	1 - 7/16	3/32	1.237	± 0.012	0.103	± 0.003	31.42	± 0.30	2.62	± 0.08
125	1 - 5/16	1 - 1/2	3/32	1.299	± 0.012	0.103	± 0.003	32.99	± 0.30	2.62	± 0.08
126	1 - 3/8	1 - 9/16	3/32	1.362	± 0.012	0.103	± 0.003	34.59	± 0.30	2.62	± 0.08
127	1 - 7/16	1 - 5/8	3/32	1.424	± 0.012	0.103	± 0.003	36.17	± 0.30	2.62	± 0.08
128	1 - 1/2	1 - 11/16	3/32	1.487	± 0.012	0.103	± 0.003	37.77	± 0.30	2.62	± 0.08
129	1 - 9/16	1 - 3/4	3/32	1.549	± 0.015	0.103	± 0.003	39.34	± 0.38	2.62	± 0.08
130	1 - 5/8	1 - 13/16	3/32	1.612	± 0.015	0.103	± 0.003	40.94	± 0.38	2.62	± 0.08
131	1 - 11/16	1 - 7/8	3/32	1.674	± 0.015	0.103	± 0.003	42.52	± 0.38	2.62	± 0.08
132	1 - 3/4	1 - 15/16	3/32	1.737	± 0.015	0.103	± 0.003	44.12	± 0.38	2.62	± 0.08
133	1 - 13/16	2	3/32	1.799	± 0.015	0.103	± 0.003	45.69	± 0.38	2.62	± 0.08
134	1 - 7/8	2 - 1/16	3/32	1.862	± 0.015	0.103	± 0.003	47.29	± 0.38	2.62	± 0.08
135	1 - 15/16	2 - 1/8	3/32	1.925	± 0.017	0.103	± 0.003	48.90	± 0.43	2.62	± 0.08
136	2	2 - 3/16	3/32	1.987	± 0.017	0.103	± 0.003	50.47	± 0.43	2.62	± 0.08

# O-Ring Sizing Charts

## Imperial O-Ring Sizes

Dash #	Nominal			Imperial Actual				Metric Actual			
	I.D.	O.D.	C/S	I.D.		C/S		I.D.		C/S	
137	2 - 1/16	2 - 1/4	3/32	2.050	± 0.017	0.103	± 0.003	52.07	± 0.43	2.62	± 0.08
138	2 - 1/8	2 - 5/16	3/32	2.112	± 0.017	0.103	± 0.003	53.64	± 0.43	2.62	± 0.08
139	2 - 3/16	2 - 3/8	3/32	2.175	± 0.017	0.103	± 0.003	55.25	± 0.43	2.62	± 0.08
140	2 - 1/4	2 - 7/16	3/32	2.237	± 0.017	0.103	± 0.003	56.82	± 0.43	2.62	± 0.08
141	2 - 5/16	2 - 1/2	3/32	2.300	± 0.020	0.103	± 0.003	58.42	± 0.51	2.62	± 0.08
142	2 - 3/8	2 - 9/16	3/32	2.362	± 0.020	0.103	± 0.003	59.99	± 0.51	2.62	± 0.08
143	2 - 7/16	2 - 5/8	3/32	2.425	± 0.020	0.103	± 0.003	61.60	± 0.51	2.62	± 0.08
144	2 - 1/2	2 - 11/16	3/32	2.487	± 0.020	0.103	± 0.003	63.17	± 0.51	2.62	± 0.08
145	2 - 9/16	2 - 3/4	3/32	2.550	± 0.020	0.103	± 0.003	64.77	± 0.51	2.62	± 0.08
146	2 - 5/8	2 - 13/16	3/32	2.612	± 0.020	0.103	± 0.003	66.34	± 0.51	2.62	± 0.08
147	2 - 11/16	2 - 7/8	3/32	2.675	± 0.022	0.103	± 0.003	67.95	± 0.56	2.62	± 0.08
148	2 - 3/4	2 - 15/16	3/32	2.737	± 0.022	0.103	± 0.003	69.52	± 0.56	2.62	± 0.08
149	2 - 13/16	3	3/32	2.800	± 0.022	0.103	± 0.003	71.12	± 0.56	2.62	± 0.08
150	2 - 7/8	3 - 1/16	3/32	2.862	± 0.022	0.103	± 0.003	72.69	± 0.56	2.62	± 0.08
151	3	3 - 3/16	3/32	2.987	± 0.024	0.103	± 0.003	75.87	± 0.61	2.62	± 0.08
152	3 - 1/4	3 - 7/16	3/32	3.237	± 0.024	0.103	± 0.003	82.22	± 0.61	2.62	± 0.08
153	3 - 1/2	3 - 11/16	3/32	3.487	± 0.024	0.103	± 0.003	88.57	± 0.61	2.62	± 0.08
154	3 - 3/4	2 - 15/16	3/32	3.737	± 0.028	0.103	± 0.003	94.92	± 0.71	2.62	± 0.08
155	4	4 - 3/16	3/32	3.987	± 0.028	0.103	± 0.003	101.27	± 0.71	2.62	± 0.08
156	4 - 1/4	4 - 7/16	3/32	4.237	± 0.030	0.103	± 0.003	107.62	± 0.76	2.62	± 0.08
157	4 - 1/2	4 - 11/16	3/32	4.487	± 0.030	0.103	± 0.003	113.97	± 0.76	2.62	± 0.08
158	4 - 3/4	4 - 15/16	3/32	4.737	± 0.030	0.103	± 0.003	120.32	± 0.76	2.62	± 0.08
159	5	5 - 3/16	3/32	4.987	± 0.035	0.103	± 0.003	126.67	± 0.89	2.62	± 0.08
160	5 - 1/4	5 - 7/16	3/32	5.237	± 0.035	0.103	± 0.003	133.02	± 0.89	2.62	± 0.08
161	5 - 1/2	5 - 11/16	3/32	5.487	± 0.035	0.103	± 0.003	139.37	± 0.89	2.62	± 0.08
162	5 - 3/4	5 - 15/16	3/32	5.737	± 0.035	0.103	± 0.003	145.72	± 0.89	2.62	± 0.08
163	6	6 - 3/16	3/32	5.987	± 0.035	0.103	± 0.003	152.07	± 0.89	2.62	± 0.08
164	6 - 1/4	6 - 7/16	3/32	6.237	± 0.040	0.103	± 0.003	158.42	± 1.02	2.62	± 0.08
165	6 - 1/2	6 - 11/16	3/32	6.487	± 0.040	0.103	± 0.003	164.77	± 1.02	2.62	± 0.08
166	6 - 3/4	6 - 15/16	3/32	6.737	± 0.040	0.103	± 0.003	171.12	± 1.02	2.62	± 0.08
167	7	7 - 3/16	3/32	6.987	± 0.040	0.103	± 0.003	177.47	± 1.02	2.62	± 0.08
168	7 - 1/4	7 - 7/16	3/32	7.237	± 0.045	0.103	± 0.003	183.82	± 1.14	2.62	± 0.08
169	7 - 1/2	7 - 11/16	3/32	7.487	± 0.045	0.103	± 0.003	190.17	± 1.14	2.62	± 0.08
170	7 - 3/4	7 - 15/16	3/32	7.737	± 0.045	0.103	± 0.003	196.52	± 1.14	2.62	± 0.08
171	8	8 - 3/16	3/32	7.987	± 0.045	0.103	± 0.003	202.87	± 1.14	2.62	± 0.08
172	8 - 1/4	8 - 7/16	3/32	8.237	± 0.050	0.103	± 0.003	209.22	± 1.27	2.62	± 0.08
173	8 - 1/2	8 - 11/16	3/32	8.487	± 0.050	0.103	± 0.003	215.57	± 1.27	2.62	± 0.08
174	8 - 3/4	8 - 15/16	3/32	8.737	± 0.050	0.103	± 0.003	221.92	± 1.27	2.62	± 0.08
175	9	9 - 3/16	3/32	8.987	± 0.050	0.103	± 0.003	228.27	± 1.27	2.62	± 0.08
176	9 - 1/4	9 - 7/16	3/32	9.237	± 0.055	0.103	± 0.003	234.62	± 1.40	2.62	± 0.08
177	9 - 1/2	9 - 11/16	3/32	9.487	± 0.055	0.103	± 0.003	240.97	± 1.40	2.62	± 0.08
178	9 - 3/4	9 - 15/16	3/32	9.737	± 0.055	0.103	± 0.003	247.32	± 1.40	2.62	± 0.08
201	3/16	7/16	1/8	0.171	± 0.005	0.139	± 0.004	4.34	± 0.13	3.53	± 0.10
202	1/4	1/2	1/8	0.234	± 0.005	0.139	± 0.004	5.94	± 0.13	3.53	± 0.10
203	5/16	9/16	1/8	0.296	± 0.005	0.139	± 0.004	7.52	± 0.13	3.53	± 0.10
204	3/8	5/8	1/8	0.359	± 0.005	0.139	± 0.004	9.12	± 0.13	3.53	± 0.10
205	7/16	11/16	1/8	0.421	± 0.005	0.139	± 0.004	10.69	± 0.13	3.53	± 0.10
206	1/2	3/4	1/8	0.484	± 0.005	0.139	± 0.004	12.29	± 0.13	3.53	± 0.10
207	9/16	13/16	1/8	0.546	± 0.007	0.139	± 0.004	13.87	± 0.18	3.53	± 0.10

Dash #	Nominal			Imperial Actual				Metric Actual			
	I.D.	O.D.	C/S	I.D.	C/S		I.D.	C/S			
208	5/8	7/8	1/8	0.609	± 0.009	0.139	± 0.004	15.47	± 0.23	3.53	± 0.10
209	11/16	15/16	1/8	0.671	± 0.009	0.139	± 0.004	17.04	± 0.23	3.53	± 0.10
210	3/4	1	1/8	0.734	± 0.010	0.139	± 0.004	18.64	± 0.25	3.53	± 0.10
211	13/16	1 - 1/16	1/8	0.796	± 0.010	0.139	± 0.004	20.22	± 0.25	3.53	± 0.10
212	7/8	1 - 1/8	1/8	0.859	± 0.010	0.139	± 0.004	21.82	± 0.25	3.53	± 0.10
213	15/16	1 - 3/16	1/8	0.921	± 0.010	0.139	± 0.004	23.39	± 0.25	3.53	± 0.10
214	1	1 - 1/4	1/8	0.984	± 0.010	0.139	± 0.004	24.99	± 0.25	3.53	± 0.10
215	1 - 1/16	1 - 5/16	1/8	1.046	± 0.010	0.139	± 0.004	26.57	± 0.25	3.53	± 0.10
216	1 - 1/8	1 - 3/8	1/8	1.109	± 0.012	0.139	± 0.004	28.17	± 0.30	3.53	± 0.10
217	1 - 3/16	1 - 7/16	1/8	1.171	± 0.012	0.139	± 0.004	29.74	± 0.30	3.53	± 0.10
218	1 - 1/4	1 - 1/2	1/8	1.234	± 0.012	0.139	± 0.004	31.34	± 0.30	3.53	± 0.10
219	1 - 5/16	1 - 9/16	1/8	1.296	± 0.012	0.139	± 0.004	32.92	± 0.30	3.53	± 0.10
220	1 - 3/8	1 - 5/8	1/8	1.359	± 0.012	0.139	± 0.004	34.52	± 0.30	3.53	± 0.10
221	1 - 7/16	1 - 11/16	1/8	1.421	± 0.012	0.139	± 0.004	36.09	± 0.30	3.53	± 0.10
222	1 - 1/2	1 - 3/4	1/8	1.484	± 0.015	0.139	± 0.004	37.69	± 0.38	3.53	± 0.10
223	1 - 5/8	1 - 7/8	1/8	1.609	± 0.015	0.139	± 0.004	40.87	± 0.38	3.53	± 0.10
224	1 - 3/4	2	1/8	1.734	± 0.015	0.139	± 0.004	44.04	± 0.38	3.53	± 0.10
225	1 - 7/8	2 - 1/8	1/8	1.859	± 0.018	0.139	± 0.004	47.22	± 0.46	3.53	± 0.10
226	2	2 - 1/4	1/8	1.984	± 0.018	0.139	± 0.004	50.39	± 0.46	3.53	± 0.10
227	2 - 1/8	2 - 3/8	1/8	2.109	± 0.018	0.139	± 0.004	53.57	± 0.46	3.53	± 0.10
228	2 - 1/4	2 - 1/2	1/8	2.234	± 0.020	0.139	± 0.004	56.74	± 0.51	3.53	± 0.10
229	2 - 3/8	2 - 5/8	1/8	2.359	± 0.020	0.139	± 0.004	59.92	± 0.51	3.53	± 0.10
230	2 - 1/2	2 - 3/4	1/8	2.484	± 0.020	0.139	± 0.004	63.09	± 0.51	3.53	± 0.10
231	2 - 5/8	2 - 7/8	1/8	2.609	± 0.020	0.139	± 0.004	66.27	± 0.51	3.53	± 0.10
232	2 - 3/4	3	1/8	2.734	± 0.024	0.139	± 0.004	69.44	± 0.61	3.53	± 0.10
233	2 - 7/8	3 - 1/8	1/8	2.859	± 0.024	0.139	± 0.004	72.62	± 0.61	3.53	± 0.10
234	3	3 - 1/4	1/8	2.984	± 0.024	0.139	± 0.004	75.79	± 0.61	3.53	± 0.10
235	3 - 1/8	3 - 3/8	1/8	3.109	± 0.024	0.139	± 0.004	78.97	± 0.61	3.53	± 0.10
236	3 - 1/4	3 - 1/2	1/8	3.234	± 0.024	0.139	± 0.004	82.14	± 0.61	3.53	± 0.10
237	3 - 3/8	3 - 5/8	1/8	3.359	± 0.024	0.139	± 0.004	85.32	± 0.61	3.53	± 0.10
238	3 - 1/2	3 - 3/4	1/8	3.484	± 0.024	0.139	± 0.004	88.49	± 0.61	3.53	± 0.10
239	3 - 5/8	3 - 7/8	1/8	3.609	± 0.028	0.139	± 0.004	91.67	± 0.71	3.53	± 0.10
240	3 - 3/4	4	1/8	3.734	± 0.028	0.139	± 0.004	94.84	± 0.71	3.53	± 0.10
241	3 - 7/8	4 - 1/8	1/8	3.859	± 0.028	0.139	± 0.004	98.02	± 0.71	3.53	± 0.10
242	4	4 - 1/4	1/8	3.984	± 0.028	0.139	± 0.004	101.19	± 0.71	3.53	± 0.10
243	4 - 1/8	4 - 3/8	1/8	4.109	± 0.028	0.139	± 0.004	104.37	± 0.71	3.53	± 0.10
244	4 - 1/4	4 - 1/2	1/8	4.234	± 0.030	0.139	± 0.004	107.54	± 0.76	3.53	± 0.10
245	4 - 3/8	4 - 5/8	1/8	4.359	± 0.030	0.139	± 0.004	110.72	± 0.76	3.53	± 0.10
246	4 - 1/2	4 - 3/4	1/8	4.484	± 0.030	0.139	± 0.004	113.89	± 0.76	3.53	± 0.10
247	4 - 5/8	4 - 7/8	1/8	4.609	± 0.030	0.139	± 0.004	117.07	± 0.76	3.53	± 0.10
248	4 - 3/4	5	1/8	4.734	± 0.030	0.139	± 0.004	120.24	± 0.76	3.53	± 0.10
249	4 - 7/8	5 - 1/8	1/8	4.859	± 0.035	0.139	± 0.004	123.42	± 0.89	3.53	± 0.10
250	5	5 - 1/4	1/8	4.984	± 0.035	0.139	± 0.004	126.59	± 0.89	3.53	± 0.10
251	5 - 1/8	5 - 3/8	1/8	5.109	± 0.035	0.139	± 0.004	129.77	± 0.89	3.53	± 0.10
252	5 - 1/4	5 - 1/2	1/8	5.234	± 0.035	0.139	± 0.004	132.94	± 0.89	3.53	± 0.10
253	5 - 3/8	5 - 5/8	1/8	5.359	± 0.035	0.139	± 0.004	136.12	± 0.89	3.53	± 0.10
254	5 - 1/2	5 - 3/4	1/8	5.484	± 0.035	0.139	± 0.004	139.29	± 0.89	3.53	± 0.10
255	5 - 5/8	5 - 7/8	1/8	5.609	± 0.035	0.139	± 0.004	142.47	± 0.89	3.53	± 0.10
256	5 - 3/4	6	1/8	5.734	± 0.035	0.139	± 0.004	145.64	± 0.89	3.53	± 0.10
257	5 - 7/8	6 - 1/8	1/8	5.859	± 0.035	0.139	± 0.004	148.82	± 0.89	3.53	± 0.10

# O-Ring Design Guide

## Imperial O-Ring Sizes

Dash #	Nominal			Imperial Actual				Metric Actual			
	I.D.	O.D.	C/S	I.D.		C/S		I.D.		C/S	
258	6	6 - 1/4	1/8	5.984	± 0.035	0.139	± 0.004	151.99	± 0.89	3.53	± 0.10
259	6 - 1/4	6 - 1/2	1/8	6.234	± 0.040	0.139	± 0.004	158.34	± 1.02	3.53	± 0.10
260	6 - 1/2	6 - 3/4	1/8	6.484	± 0.040	0.139	± 0.004	164.69	± 1.02	3.53	± 0.10
261	6 - 3/4	7	1/8	6.734	± 0.040	0.139	± 0.004	171.04	± 1.02	3.53	± 0.10
262	7	7 - 1/4	1/8	6.984	± 0.040	0.139	± 0.004	177.39	± 1.02	3.53	± 0.10
263	7 - 1/4	7 - 1/2	1/8	7.234	± 0.045	0.139	± 0.004	183.74	± 1.14	3.53	± 0.10
264	7 - 1/2	7 - 3/4	1/8	7.484	± 0.045	0.139	± 0.004	190.09	± 1.14	3.53	± 0.10
265	7 - 3/4	8	1/8	7.734	± 0.045	0.139	± 0.004	196.44	± 1.14	3.53	± 0.10
266	8	8 - 1/4	1/8	7.984	± 0.045	0.139	± 0.004	202.79	± 1.14	3.53	± 0.10
267	8 - 1/4	8 - 1/2	1/8	8.234	± 0.050	0.139	± 0.004	209.14	± 1.27	3.53	± 0.10
268	8 - 1/2	8 - 3/4	1/8	8.484	± 0.050	0.139	± 0.004	215.49	± 1.27	3.53	± 0.10
269	8 - 3/4	9	1/8	8.734	± 0.050	0.139	± 0.004	221.84	± 1.27	3.53	± 0.10
270	9	9 - 1/4	1/8	8.984	± 0.050	0.139	± 0.004	228.19	± 1.27	3.53	± 0.10
271	9 - 1/4	9 - 1/2	1/8	9.234	± 0.055	0.139	± 0.004	234.54	± 1.40	3.53	± 0.10
272	9 - 1/2	9 - 3/4	1/8	9.484	± 0.055	0.139	± 0.004	240.89	± 1.40	3.53	± 0.10
273	9 - 3/4	10	1/8	9.734	± 0.055	0.139	± 0.004	247.24	± 1.40	3.53	± 0.10
274	10	10 - 1/4	1/8	9.984	± 0.055	0.139	± 0.004	253.59	± 1.40	3.53	± 0.10
275	10 - 1/2	10 - 3/4	1/8	10.484	± 0.055	0.139	± 0.004	266.29	± 1.40	3.53	± 0.10
276	11	11 - 1/4	1/8	10.984	± 0.065	0.139	± 0.004	278.99	± 1.65	3.53	± 0.10
277	11 - 1/2	11 - 3/4	1/8	11.484	± 0.065	0.139	± 0.004	291.69	± 1.65	3.53	± 0.10
278	12	12 - 1/4	1/8	11.984	± 0.065	0.139	± 0.004	304.39	± 1.65	3.53	± 0.10
279	13	13 - 1/4	1/8	12.984	± 0.065	0.139	± 0.004	329.79	± 1.65	3.53	± 0.10
280	14	14 - 1/4	1/8	13.984	± 0.065	0.139	± 0.004	355.19	± 1.65	3.53	± 0.10
281	15	15 - 1/4	1/8	14.984	± 0.065	0.139	± 0.004	380.59	± 1.65	3.53	± 0.10
282	16	16 - 1/4	1/8	15.955	± 0.075	0.139	± 0.004	405.26	± 1.91	3.53	± 0.10
283	17	17 - 1/4	1/8	16.956	± 0.080	0.139	± 0.004	430.68	± 2.03	3.53	± 0.10
284	18	18 - 1/4	1/8	17.955	± 0.085	0.139	± 0.004	456.06	± 2.16	3.53	± 0.10
309	7/16	13/16	3/16	0.412	± 0.005	0.210	± 0.005	10.46	± 0.13	5.33	± 0.13
310	1/2	7/8	3/16	0.475	± 0.005	0.210	± 0.005	12.07	± 0.13	5.33	± 0.13
311	9/16	15/16	3/16	0.537	± 0.007	0.210	± 0.005	13.64	± 0.18	5.33	± 0.13
312	5/8	1	3/16	0.600	± 0.009	0.210	± 0.005	15.24	± 0.23	5.33	± 0.13
313	11/16	1 - 1/16	3/16	0.662	± 0.009	0.210	± 0.005	16.81	± 0.23	5.33	± 0.13
314	3/4	1 - 1/8	3/16	0.725	± 0.010	0.210	± 0.005	18.42	± 0.25	5.33	± 0.13
315	13/16	1 - 3/16	3/16	0.787	± 0.010	0.210	± 0.005	19.99	± 0.25	5.33	± 0.13
316	7/8	1 - 1/4	3/16	0.850	± 0.010	0.210	± 0.005	21.59	± 0.25	5.33	± 0.13
317	15/16	1 - 5/16	3/16	0.912	± 0.010	0.210	± 0.005	23.16	± 0.25	5.33	± 0.13
318	1	1 - 3/8	3/16	0.975	± 0.010	0.210	± 0.005	24.77	± 0.25	5.33	± 0.13
319	1 - 1/16	1 - 7/16	3/16	1.037	± 0.010	0.210	± 0.005	26.34	± 0.25	5.33	± 0.13
320	1 - 1/8	1 - 1/2	3/16	1.100	± 0.012	0.210	± 0.005	27.94	± 0.30	5.33	± 0.13
321	1 - 3/16	1 - 9/16	3/16	1.162	± 0.012	0.210	± 0.005	29.51	± 0.30	5.33	± 0.13
322	1 - 1/4	1 - 5/8	3/16	1.225	± 0.012	0.210	± 0.005	31.12	± 0.30	5.33	± 0.13
323	1 - 5/16	1 - 11/16	3/16	1.287	± 0.012	0.210	± 0.005	32.69	± 0.30	5.33	± 0.13
324	1 - 3/8	1 - 3/4	3/16	1.350	± 0.012	0.210	± 0.005	34.29	± 0.38	5.33	± 0.13
325	1 - 1/2	1 - 7/8	3/16	1.475	± 0.015	0.210	± 0.005	37.47	± 0.38	5.33	± 0.13
326	1 - 5/8	2	3/16	1.600	± 0.015	0.210	± 0.005	40.64	± 0.38	5.33	± 0.13
327	1 - 3/4	2 - 1/8	3/16	1.725	± 0.015	0.210	± 0.005	43.82	± 0.38	5.33	± 0.13
328	1 - 7/8	2 - 1/4	3/16	1.850	± 0.015	0.210	± 0.005	46.99	± 0.38	5.33	± 0.13
329	2	2 - 3/8	3/16	1.975	± 0.018	0.210	± 0.005	50.17	± 0.46	5.33	± 0.13
330	2 - 1/8	2 - 1/2	3/16	2.100	± 0.018	0.210	± 0.005	53.34	± 0.46	5.33	± 0.13

Dash #	Nominal			Imperial Actual				Metric Actual			
	I.D.	O.D.	C/S	I.D.		C/S		I.D.		C/S	
331	2 - 1/4	2 - 5/8	3/16	2.225	± 0.018	0.210	± 0.005	56.52	± 0.46	5.33	± 0.13
332	2 - 3/8	2 - 3/4	3/16	2.350	± 0.018	0.210	± 0.005	59.69	± 0.46	5.33	± 0.13
333	2 - 1/2	2 - 7/8	3/16	2.475	± 0.020	0.210	± 0.005	62.87	± 0.51	5.33	± 0.13
334	2 - 5/8	3	3/16	2.600	± 0.020	0.210	± 0.005	66.04	± 0.51	5.33	± 0.13
335	2 - 3/4	3 - 1/8	3/16	2.725	± 0.020	0.210	± 0.005	69.22	± 0.51	5.33	± 0.13
336	2 - 7/8	3 - 1/4	3/16	2.850	± 0.020	0.210	± 0.005	72.39	± 0.51	5.33	± 0.13
337	3	3 - 3/8	3/16	2.975	± 0.024	0.210	± 0.005	75.57	± 0.61	5.33	± 0.13
338	3 - 1/8	3 - 1/2	3/16	3.100	± 0.024	0.210	± 0.005	78.74	± 0.61	5.33	± 0.13
339	3 - 1/4	3 - 5/8	3/16	3.225	± 0.024	0.210	± 0.005	81.92	± 0.61	5.33	± 0.13
340	3 - 3/8	3 - 3/4	3/16	3.350	± 0.024	0.210	± 0.005	85.09	± 0.61	5.33	± 0.13
341	3 - 1/2	3 - 7/8	3/16	3.475	± 0.024	0.210	± 0.005	88.27	± 0.61	5.33	± 0.13
342	3 - 5/8	4	3/16	3.600	± 0.028	0.210	± 0.005	91.44	± 0.71	5.33	± 0.13
343	3 - 3/4	4 - 1/8	3/16	3.725	± 0.028	0.210	± 0.005	94.62	± 0.71	5.33	± 0.13
344	3 - 7/8	4 - 1/4	3/16	3.850	± 0.028	0.210	± 0.005	97.79	± 0.71	5.33	± 0.13
345	4	4 - 3/8	3/16	3.975	± 0.028	0.210	± 0.005	100.97	± 0.71	5.33	± 0.13
346	4 - 1/8	4 - 1/2	3/16	4.100	± 0.028	0.210	± 0.005	104.14	± 0.71	5.33	± 0.13
347	4 - 1/4	4 - 5/8	3/16	4.225	± 0.030	0.210	± 0.005	107.32	± 0.76	5.33	± 0.13
348	4 - 3/8	4 - 3/4	3/16	4.350	± 0.030	0.210	± 0.005	110.49	± 0.76	5.33	± 0.13
349	4 - 1/2	4 - 7/8	3/16	4.475	± 0.030	0.210	± 0.005	113.67	± 0.76	5.33	± 0.13
350	4 - 5/8	5	3/16	4.600	± 0.030	0.210	± 0.005	116.84	± 0.76	5.33	± 0.13
351	4 - 3/4	5 - 1/8	3/16	4.725	± 0.030	0.210	± 0.005	120.02	± 0.76	5.33	± 0.13
352	4 - 7/8	5 - 1/4	3/16	4.850	± 0.030	0.210	± 0.005	123.19	± 0.76	5.33	± 0.13
353	5	5 - 3/8	3/16	4.975	± 0.037	0.210	± 0.005	126.37	± 0.94	5.33	± 0.13
354	5 - 1/8	5 - 1/2	3/16	5.100	± 0.037	0.210	± 0.005	129.54	± 0.94	5.33	± 0.13
355	5 - 1/4	5 - 5/8	3/16	5.225	± 0.037	0.210	± 0.005	132.72	± 0.94	5.33	± 0.13
356	5 - 3/8	5 - 3/4	3/16	5.350	± 0.037	0.210	± 0.005	135.89	± 0.94	5.33	± 0.13
357	5 - 1/2	5 - 7/8	3/16	5.475	± 0.037	0.210	± 0.005	139.07	± 0.94	5.33	± 0.13
358	5 - 5/8	6	3/16	5.600	± 0.037	0.210	± 0.005	142.24	± 0.94	5.33	± 0.13
359	5 - 3/4	6 - 1/8	3/16	5.725	± 0.037	0.210	± 0.005	145.42	± 0.94	5.33	± 0.13
360	5 - 7/8	6 - 1/4	3/16	5.850	± 0.037	0.210	± 0.005	148.59	± 0.94	5.33	± 0.13
361	6	6 - 3/8	3/16	5.975	± 0.037	0.210	± 0.005	151.77	± 0.94	5.33	± 0.13
362	6 - 1/4	6 - 5/8	3/16	6.225	± 0.040	0.210	± 0.005	158.12	± 1.02	5.33	± 0.13
363	6 - 1/2	6 - 7/8	3/16	6.475	± 0.040	0.210	± 0.005	164.47	± 1.02	5.33	± 0.13
364	6 - 3/4	7 - 1/8	3/16	6.725	± 0.040	0.210	± 0.005	170.82	± 1.02	5.33	± 0.13
365	7	7 - 3/8	3/16	6.975	± 0.040	0.210	± 0.005	177.17	± 1.02	5.33	± 0.13
366	7 - 1/4	7 - 5/8	3/16	7.225	± 0.045	0.210	± 0.005	183.52	± 1.14	5.33	± 0.13
367	7 - 1/2	7 - 7/8	3/16	7.475	± 0.045	0.210	± 0.005	189.87	± 1.14	5.33	± 0.13
368	7 - 3/4	8 - 1/8	3/16	7.725	± 0.045	0.210	± 0.005	196.22	± 1.14	5.33	± 0.13
369	8	8 - 3/8	3/16	7.975	± 0.045	0.210	± 0.005	202.57	± 1.14	5.33	± 0.13
370	8 - 1/4	8 - 5/8	3/16	8.225	± 0.050	0.210	± 0.005	208.92	± 1.27	5.33	± 0.13
371	8 - 1/2	8 - 7/8	3/16	8.475	± 0.050	0.210	± 0.005	215.27	± 1.27	5.33	± 0.13
372	8 - 3/4	9 - 1/8	3/16	8.725	± 0.050	0.210	± 0.005	221.62	± 1.27	5.33	± 0.13
373	9	9 - 3/8	3/16	8.975	± 0.050	0.210	± 0.005	227.97	± 1.27	5.33	± 0.13
374	9 - 1/4	9 - 5/8	3/16	9.225	± 0.055	0.210	± 0.005	234.32	± 1.40	5.33	± 0.13
375	9 - 1/2	9 - 7/8	3/16	9.475	± 0.055	0.210	± 0.005	240.67	± 1.40	5.33	± 0.13
376	9 - 3/4	10 - 1/8	3/16	9.725	± 0.055	0.210	± 0.005	247.02	± 1.40	5.33	± 0.13
377	10	10 - 3/8	3/16	9.975	± 0.055	0.210	± 0.005	253.37	± 1.40	5.33	± 0.13
378	10 - 1/2	10 - 7/8	3/16	10.475	± 0.060	0.210	± 0.005	266.07	± 1.52	5.33	± 0.13
379	11	11 - 3/8	3/16	10.975	± 0.060	0.210	± 0.005	278.77	± 1.52	5.33	± 0.13
380	11 - 1/2	11 - 7/8	3/16	11.475	± 0.065	0.210	± 0.005	291.47	± 1.65	5.33	± 0.13

# O-Ring Sizing Charts

## Imperial O-Ring Sizes

Dash #	Nominal			Imperial Actual				Metric Actual			
	I.D.	O.D.	C/S	I.D.		C/S		I.D.		C/S	
381	12	12 - 3/8	3/16	11.975	± 0.065	0.210	± 0.005	304.17	± 1.65	5.33	± 0.13
382	13	13 - 3/8	3/16	12.975	± 0.065	0.210	± 0.005	329.57	± 1.65	5.33	± 0.13
383	14	14 - 3/8	3/16	13.975	± 0.070	0.210	± 0.005	354.97	± 1.78	5.33	± 0.13
384	15	15 - 3/8	3/16	14.975	± 0.070	0.210	± 0.005	380.37	± 1.78	5.33	± 0.13
385	16	16 - 3/8	3/16	15.955	± 0.075	0.210	± 0.005	405.26	± 1.91	5.33	± 0.13
386	17	17 - 3/8	3/16	16.955	± 0.080	0.210	± 0.005	430.66	± 2.03	5.33	± 0.13
387	18	18 - 3/8	3/16	17.955	± 0.085	0.210	± 0.005	456.06	± 2.16	5.33	± 0.13
388	19	19 - 3/8	3/16	18.952	± 0.090	0.210	± 0.005	481.38	± 2.29	5.33	± 0.13
389	20	20 - 3/8	3/16	19.952	± 0.095	0.210	± 0.005	506.78	± 2.41	5.33	± 0.13
390	21	21 - 3/8	3/16	20.952	± 0.095	0.210	± 0.005	532.18	± 2.41	5.33	± 0.13
391	22	22 - 3/8	3/16	21.952	± 0.100	0.210	± 0.005	557.58	± 2.54	5.33	± 0.13
392	23	23 - 3/8	3/16	22.940	± 0.105	0.210	± 0.005	582.68	± 2.67	5.33	± 0.13
393	24	24 - 3/8	3/16	23.940	± 0.110	0.210	± 0.005	608.08	± 2.79	5.33	± 0.13
394	25	25 - 3/8	3/16	24.940	± 0.115	0.210	± 0.005	633.48	± 2.92	5.33	± 0.13
395	26	26 - 3/8	3/16	25.940	± 0.120	0.210	± 0.005	658.88	± 3.05	5.33	± 0.13
425	4 - 1/2	5	1/4	4.475	± 0.033	0.275	± 0.006	113.67	± 0.84	6.99	± 0.15
426	4 - 5/8	5 - 1/8	1/4	4.600	± 0.033	0.275	± 0.006	116.84	± 0.84	6.99	± 0.15
427	4 - 3/4	5 - 1/4	1/4	4.725	± 0.033	0.275	± 0.006	120.02	± 0.84	6.99	± 0.15
428	4 - 7/8	5 - 3/8	1/4	4.850	± 0.033	0.275	± 0.006	123.19	± 0.84	6.99	± 0.15
429	5	5 - 1/2	1/4	4.975	± 0.037	0.275	± 0.006	126.37	± 0.94	6.99	± 0.15
430	5 - 1/8	5 - 5/8	1/4	5.100	± 0.037	0.275	± 0.006	129.54	± 0.94	6.99	± 0.15
431	5 - 1/4	5 - 3/4	1/4	5.225	± 0.037	0.275	± 0.006	132.72	± 0.94	6.99	± 0.15
432	5 - 3/8	5 - 7/8	1/4	5.350	± 0.037	0.275	± 0.006	135.89	± 0.94	6.99	± 0.15
433	5 - 1/2	6	1/4	5.475	± 0.037	0.275	± 0.006	139.07	± 0.94	6.99	± 0.15
434	5 - 5/8	6 - 1/8	1/4	5.600	± 0.037	0.275	± 0.006	142.24	± 0.94	6.99	± 0.15
435	5 - 3/4	6 - 1/4	1/4	5.725	± 0.037	0.275	± 0.006	145.42	± 0.94	6.99	± 0.15
436	5 - 7/8	6 - 3/8	1/4	5.850	± 0.037	0.275	± 0.006	148.59	± 0.94	6.99	± 0.15
437	6	6 - 1/2	1/4	5.975	± 0.037	0.275	± 0.006	151.77	± 0.94	6.99	± 0.15
438	6 - 1/4	6 - 3/4	1/4	6.225	± 0.040	0.275	± 0.006	158.12	± 1.02	6.99	± 0.15
439	6 - 1/2	7	1/4	6.475	± 0.040	0.275	± 0.006	164.47	± 1.02	6.99	± 0.15
440	6 - 3/4	7 - 1/4	1/4	6.725	± 0.040	0.275	± 0.006	170.82	± 1.02	6.99	± 0.15
441	7	7 - 1/2	1/4	6.975	± 0.040	0.275	± 0.006	177.17	± 1.02	6.99	± 0.15
442	7 - 1/4	7 - 3/4	1/4	7.225	± 0.045	0.275	± 0.006	183.52	± 1.14	6.99	± 0.15
443	7 - 1/2	8	1/4	7.475	± 0.045	0.275	± 0.006	189.87	± 1.14	6.99	± 0.15
444	7 - 3/4	8 - 1/4	1/4	7.725	± 0.045	0.275	± 0.006	196.22	± 1.14	6.99	± 0.15
445	8	8 - 1/2	1/4	7.975	± 0.045	0.275	± 0.006	202.57	± 1.14	6.99	± 0.15
446	8 - 1/2	9	1/4	8.475	± 0.055	0.275	± 0.006	215.27	± 1.40	6.99	± 0.15
447	9	9 - 1/2	1/4	8.975	± 0.055	0.275	± 0.006	227.97	± 1.40	6.99	± 0.15
448	9 - 1/2	10	1/4	9.475	± 0.055	0.275	± 0.006	240.67	± 1.40	6.99	± 0.15
449	10	10 - 1/2	1/4	9.975	± 0.055	0.275	± 0.006	253.37	± 1.40	6.99	± 0.15
450	10 - 1/2	11	1/4	10.475	± 0.060	0.275	± 0.006	266.07	± 1.52	6.99	± 0.15
451	11	11 - 1/2	1/4	10.975	± 0.060	0.275	± 0.006	278.77	± 1.52	6.99	± 0.15
452	11 - 1/2	12	1/4	11.475	± 0.060	0.275	± 0.006	291.47	± 1.52	6.99	± 0.15
453	12	12 - 1/2	1/4	11.975	± 0.060	0.275	± 0.006	304.17	± 1.52	6.99	± 0.15
454	12 - 1/2	13	1/4	12.475	± 0.060	0.275	± 0.006	316.87	± 1.52	6.99	± 0.15
455	13	13 - 1/2	1/4	12.975	± 0.060	0.275	± 0.006	329.57	± 1.52	6.99	± 0.15
456	13 - 1/2	14	1/4	13.475	± 0.070	0.275	± 0.006	342.27	± 1.78	6.99	± 0.15
457	14	14 - 1/2	1/4	13.975	± 0.070	0.275	± 0.006	345.97	± 1.78	6.99	± 0.15
458	14 - 1/2	15	1/4	14.475	± 0.070	0.275	± 0.006	367.67	± 1.78	6.99	± 0.15

Dash #	Nominal			Actual Sizing				Metric Actual			
	I.D.	O.D.	C/S	I.D.		C/S		I.D.		C/S	
459	15	15 - 1/2	1/4	14.975	± 0.070	0.275	± 0.006	380.37	± 1.78	6.99	± 0.15
460	15 - 1/2	16	1/4	15.475	± 0.070	0.275	± 0.006	393.07	± 1.78	6.99	± 0.15
461	16	16 - 1/2	1/4	15.955	± 0.075	0.275	± 0.006	405.26	± 1.91	6.99	± 0.15
462	16 - 1/2	17	1/4	16.455	± 0.075	0.275	± 0.006	417.96	± 1.91	6.99	± 0.15
463	17	17 - 1/2	1/4	16.955	± 0.080	0.275	± 0.006	430.66	± 2.03	6.99	± 0.15
464	17 - 1/2	18	1/4	17.455	± 0.085	0.275	± 0.006	443.36	± 2.16	6.99	± 0.15
465	18	18 - 1/2	1/4	17.955	± 0.085	0.275	± 0.006	456.06	± 2.16	6.99	± 0.15
466	18 - 1/2	19	1/4	18.455	± 0.085	0.275	± 0.006	468.76	± 2.16	6.99	± 0.15
467	19	19 - 1/2	1/4	18.955	± 0.090	0.275	± 0.006	481.46	± 2.29	6.99	± 0.15
468	19 - 1/2	20	1/4	19.455	± 0.090	0.275	± 0.006	494.16	± 2.29	6.99	± 0.15
469	20	20 - 1/2	1/4	19.955	± 0.095	0.275	± 0.006	506.86	± 2.41	6.99	± 0.15
470	21	21 - 1/2	1/4	20.955	± 0.095	0.275	± 0.006	532.26	± 2.41	6.99	± 0.15
471	22	22 - 1/2	1/4	21.955	± 0.100	0.275	± 0.006	557.66	± 2.54	6.99	± 0.15
472	23	23 - 1/2	1/4	22.940	± 0.105	0.275	± 0.006	582.68	± 2.67	6.99	± 0.15
473	24	24 - 1/2	1/4	23.940	± 0.110	0.275	± 0.006	608.08	± 2.79	6.99	± 0.15
474	25	25 - 1/2	1/4	24.940	± 0.115	0.275	± 0.006	633.48	± 2.92	6.99	± 0.15
475	26	26 - 1/2	1/4	25.940	± 0.120	0.275	± 0.006	658.88	± 3.05	6.99	± 0.15

We offer O-rings in sizes ranging from 400-424. These O-ring size dimensions and tolerances are unassigned under ISO 3601. In addition, Hi-Tech Seals stocks specific non-standard cross-section O-rings such as 3/8", 1/2" and 3/4".

### O-Ring for Tube Fitting Bosses

Dash #	Tube Size OD Inch	Hydraulic MIL-P-5570 MS28778	Actual Sizing				Metric Actual			
			I.D.		C/S		I.D.		C/S	
901	3/32		0.185	± 0.005	0.056	± 0.003	4.70	± 0.13	1.42	± 0.08
902	1/8	2	0.239	± 0.005	0.064	± 0.003	6.07	± 0.13	1.63	± 0.08
903	3/16	3	0.301	± 0.005	0.064	± 0.003	7.65	± 0.13	1.63	± 0.08
904	1/4	4	0.351	± 0.005	0.072	± 0.003	8.92	± 0.13	1.83	± 0.08
905	5/16	5	0.414	± 0.005	0.072	± 0.003	10.52	± 0.13	1.83	± 0.08
906	3/8	6	0.468	± 0.005	0.078	± 0.003	11.89	± 0.13	1.98	± 0.08
907	7/16		0.530	± 0.005	0.082	± 0.003	13.46	± 0.13	2.08	± 0.08
908	1/2	8	0.644	± 0.009	0.087	± 0.003	16.36	± 0.23	2.21	± 0.08
909	9/16		0.706	± 0.009	0.097	± 0.003	17.93	± 0.23	2.46	± 0.08
910	5/8	10	0.755	± 0.009	0.097	± 0.003	19.18	± 0.23	2.46	± 0.08
911	11/16		0.863	± 0.009	0.116	± 0.004	21.92	± 0.23	2.95	± 0.10
912	3/4	12	0.924	± 0.009	0.116	± 0.004	23.47	± 0.23	2.95	± 0.10
913	13/16		0.986	± 0.010	0.116	± 0.004	25.04	± 0.25	2.95	± 0.10
914	7/8	14	1.048	± 0.010	0.116	± 0.004	26.62	± 0.25	2.95	± 0.10
916	1	16	1.171	± 0.010	0.116	± 0.004	29.74	± 0.25	2.95	± 0.10
918	1-1/8		1.355	± 0.012	0.116	± 0.004	34.42	± 0.30	2.95	± 0.10
920	1-1/4	20	1.475	± 0.014	0.118	± 0.004	37.47	± 0.36	3.00	± 0.10
924	1-1/2	24	1.720	± 0.014	0.118	± 0.004	43.69	± 0.36	3.00	± 0.10
928	1-3/4	28	2.090	± 0.018	0.118	± 0.004	53.09	± 0.36	3.00	± 0.10
932	2	32	2.337	± 0.018	0.118	± 0.004	59.36	± 0.36	3.00	± 0.10

# O-Ring Sizing Charts

## Metric O-Ring Sizes

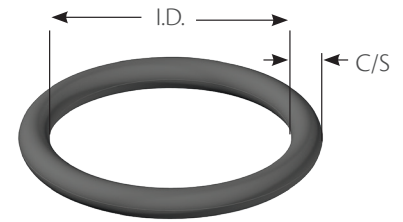
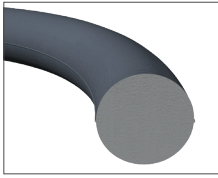

Part Number	C/S	I.D.	Cross Ref. #
1000115	1.00	1.15	
1000125	1.00	1.25	
100015	1.00	1.50	
100018	1.00	1.80	
10002	1.00	2.00	
100025	1.00	2.50	
100027	1.00	2.70	
10003	1.00	3.00	
100033	1.00	3.30	
100035	1.00	3.50	
10004	1.00	4.00	
100045	1.00	4.50	
10005	1.00	5.00	
100055	1.00	5.50	
10006	1.00	6.00	
100065	1.00	6.50	
10007	1.00	7.00	
100072	1.00	7.20	
100075	1.00	7.50	
10008	1.00	8.00	
100085	1.00	8.50	
10009	1.00	9.00	
100095	1.00	9.50	
10010	1.00	10.00	
100105	1.00	10.50	
10011	1.00	11.00	
100115	1.00	11.50	
10012	1.00	12.00	
100125	1.00	12.50	
10013	1.00	13.00	
100135	1.00	13.50	
10014	1.00	14.00	
100145	1.00	14.50	
10015	1.00	15.00	
100155	1.00	15.50	
10016	1.00	16.00	
100165	1.00	16.50	
10017	1.00	17.00	
10018	1.00	18.00	
100185	1.00	18.50	
10019	1.00	19.00	
100195	1.00	19.50	
10020	1.00	20.00	

Part Number	C/S	I.D.	Cross Ref. #
100205	1.00	20.50	
10021	1.00	21.00	
100215	1.00	21.50	
10022	1.00	22.00	
100225	1.00	22.50	
10023	1.00	23.00	
100235	1.00	23.50	
10024	1.00	24.00	
100245	1.00	24.50	
10025	1.00	25.00	
10028	1.00	28.00	
100294	1.00	29.40	
100299	1.00	29.90	
100305	1.00	30.50	
100318	1.00	31.80	
10032	1.00	32.00	
10039	1.00	39.00	
10042	1.00	42.00	
10060	1.00	60.00	
-001	1.02	0.74	-001
120025	1.20	2.50	
120026	1.20	2.60	
120035	1.20	3.50	
12005	1.20	5.00	
12024	1.20	24.00	
12026	1.20	26.00	
12028	1.20	28.00	
12035	1.20	35.00	
12040	1.20	40.00	
120535	1.20	53.50	
12098	1.20	98.00	
-002	1.27	1.07	-002
150018	1.50	1.80	
1500185	1.50	1.85	
15002	1.50	2.00	
150025	1.50	2.50	S 3
150028	1.50	2.80	
15003	1.50	3.00	
150035	1.50	3.50	S 4
15004	1.50	4.00	
150045	1.50	4.50	S 5
15005	1.50	5.00	
150055	1.50	5.50	S 6

Part Number	C/S	I.D.	Cross Ref. #
15006	1.50	6.00	
150065	1.50	6.50	S 7
15007	1.50	7.00	
150075	1.50	7.50	S 8
15008	1.50	8.00	
150085	1.50	8.50	S 9
15009	1.50	9.00	
150095	1.50	9.50	S 10
15010	1.50	10.00	
150105	1.50	10.50	
150107	1.50	10.70	S 11.2
15011	1.50	11.00	
150115	1.50	11.50	S 12
15012	1.50	12.00	S 12.5
150125	1.50	12.50	
15013	1.50	13.00	
1501325	1.50	13.25	
150135	1.50	13.50	S 14
15014	1.50	14.00	
15015	1.50	15.00	
150155	1.50	15.50	S 16
15016	1.50	16.00	
150165	1.50	16.50	
15017	1.50	17.00	
150175	1.50	17.50	S 18
15018	1.50	18.00	
150185	1.50	18.50	
15019	1.50	19.00	
150195	1.50	19.50	S 20
15020	1.50	20.00	
150205	1.50	20.50	
15021	1.50	21.00	
150215	1.50	21.5	S 22
15022	1.50	22.00	
150225	1.50	22.50	
15023	1.50	23.00	
150235	1.50	23.50	
15024	1.50	24.00	
150245	1.50	24.50	
15025	1.50	25.00	
150255	1.50	25.50	
15026	1.50	26.00	
150265	1.50	26.50	



Part Number	C/S	I.D.	Cross Ref. #
15027	1.50	27.00	
150275	1.50	27.50	
15028	1.50	28.00	
150285	1.50	28.50	
15029	1.50	29.00	
150295	1.50	29.50	
15030	1.50	30.00	
150305	1.50	30.50	
15031	1.50	31.00	
150315	1.50	31.50	
15032	1.50	32.00	
150325	1.50	32.50	
15033	1.50	33.00	
150335	1.50	33.50	
15034	1.50	34.00	
150345	1.50	34.50	
15035	1.50	35.00	
150355	1.50	35.50	
15036	1.50	36.00	
150365	1.50	36.50	
15037	1.50	37.00	
150375	1.50	37.50	
15038	1.50	38.00	
150385	1.50	38.50	
15039	1.50	39.00	
150395	1.50	39.50	
15040	1.50	40.00	
15041	1.50	41.00	
15042	1.50	42.00	
15043	1.50	43.00	
15044	1.50	44.00	
15045	1.50	45.00	
15046	1.50	46.00	
15047	1.50	47.00	
15048	1.50	48.00	
15049	1.50	49.00	
15050	1.50	50.00	
15051	1.50	51.00	
15052	1.50	52.00	
15053	1.50	53.00	
15054	1.50	54.00	
15055	1.50	55.00	
15056	1.50	56.00	
15057	1.50	57.00	
15058	1.50	58.00	
15059	1.50	59.00	
15060	1.50	60.00	
15061	1.50	61.00	
15062	1.50	62.00	
15063	1.50	63.00	
15064	1.50	64.00	

Part Number	C/S	I.D.	Cross Ref. #
15065	1.50	65.00	
15066	1.50	66.00	
15067	1.50	67.00	
15068	1.50	68.00	
15069	1.50	69.00	
15070	1.50	70.00	
15071	1.50	71.00	
15072	1.50	72.00	
15073	1.50	73.00	
15074	1.50	74.00	
15075	1.50	75.00	
15076	1.50	76.00	
15077	1.50	77.00	
15078	1.50	78.00	
15079	1.50	79.00	
15080	1.50	80.00	
15081	1.50	81.00	
15082	1.50	82.00	
15083	1.50	83.00	
15084	1.50	84.00	
15085	1.50	85.00	
15086	1.50	86.00	
15087	1.50	87.00	
15088	1.50	88.00	
15089	1.50	89.00	
15090	1.50	90.00	
15091	1.50	91.00	
15092	1.50	92.00	
15093	1.50	93.00	
15094	1.50	94.00	
15095	1.50	95.00	
15096	1.50	96.00	
15097	1.50	97.00	
15098	1.50	98.00	
15099	1.50	99.00	
15100	1.50	100.00	
15105	1.50	105.00	
15145	1.50	145.00	
-003	1.52	1.42	-003
160022	1.60	2.20	
1600275	1.60	2.75	
160028	1.60	2.80	
160031	1.60	3.10	
160032	1.60	3.20	
160037	1.60	3.70	
160041	1.60	4.10	
160047	1.60	4.70	
160050	1.60	5.00	
160051	1.60	5.10	
160061	1.60	6.10	
160068	1.60	6.80	

Part Number	C/S	I.D.	Cross Ref. #
160071	1.60	7.10	
160081	1.60	8.10	
160091	1.60	9.10	
160101	1.60	10.10	
160111	1.60	11.10	
160121	1.60	12.10	
160131	1.60	13.10	
160141	1.60	14.10	
160151	1.60	15.10	
160161	1.60	16.10	
160171	1.60	17.10	
160181	1.60	18.10	
160191	1.60	19.10	
160203	1.60	20.30	
160211	1.60	21.10	
160221	1.60	22.10	
160251	1.60	25.10	
160271	1.60	27.10	
160291	1.60	29.10	
160321	1.60	32.10	
160351	1.60	35.10	
160371	1.60	37.10	
160511	1.60	51.10	
160860	1.60	86.00	
160966	1.60	96.60	
16115	1.60	115.00	
-004	1.78	1.78	-004
-005	1.78	2.57	-005
-006	1.78	2.90	-006
-007	1.78	3.68	-007
-008	1.78	4.47	-008
-009	1.78	5.28	-009
-010	1.78	6.07	-010
-011	1.78	7.65	-011
-012	1.78	9.25	-012
-013	1.78	10.82	-013
-014	1.78	12.42	-014
-015	1.78	14.00	-015
-016	1.78	15.60	-016
-017	1.78	17.17	-017
-018	1.78	18.77	-018
-019	1.78	20.35	-019
-020	1.78	21.95	-020
-021	1.78	23.52	-021
-022	1.78	25.12	-022
-023	1.78	26.70	-023
-024	1.78	28.30	-024
-025	1.78	29.87	-025
-026	1.78	31.47	-026
-027	1.78	33.05	-027
-028	1.78	34.65	-028

# O-Ring Sizing Charts

## Metric O-Ring Sizes

Part Number	C/S	I.D.	Cross Ref. #
-029	1.78	37.82	-029
-030	1.78	41.00	-030
-031	1.78	44.17	-031
-032	1.78	47.35	-032
-033	1.78	50.52	-033
-034	1.78	53.70	-034
-035	1.78	56.87	-035
-036	1.78	60.05	-036
-037	1.78	63.22	-037
-038	1.78	66.40	-038
-039	1.78	69.57	-039
-040	1.78	72.75	-040
-041	1.78	75.92	-041
-042	1.78	82.27	-042
-043	1.78	88.62	-043
-044	1.78	94.97	-044
-045	1.78	101.32	-045
-046	1.78	107.67	-046
-047	1.78	114.02	-047
-048	1.78	120.37	-048
-049	1.78	126.72	-049
-050	1.78	133.07	-050
180018	1.80	1.80	
18002	1.80	2.00	
1800224	1.80	2.24	
180025	1.80	2.50	
180028	1.80	2.80	
1800315	1.80	3.15	
1800355	1.80	3.55	
1800375	1.80	3.75	
18004	1.80	4.00	
180045	1.80	4.50	
1800487	1.80	4.87	
18005	1.80	5.00	
1800515	1.80	5.15	
180053	1.80	5.30	
180056	1.80	5.60	
18006	1.80	6.00	
180063	1.80	6.30	
180067	1.80	6.70	
180069	1.80	6.90	
180071	1.80	7.10	
180075	1.80	7.50	
18008	1.80	8.00	
180085	1.80	8.50	
1800876	1.80	8.76	
18009	1.80	9.00	
180095	1.80	9.50	
18010	1.80	10.00	
180106	1.80	10.60	
180112	1.80	11.20	

Part Number	C/S	I.D.	Cross Ref. #
180118	1.80	11.80	
180125	1.80	12.50	
180132	1.80	13.20	
18014	1.80	14.00	
18015	1.80	15.00	
18016	1.80	16.00	
18017	1.80	17.00	
190024	1.90	2.40	
190026	1.90	2.60	
190028	1.90	2.80	P 3
190034	1.90	3.40	
190037	1.90	3.70	
190038	1.90	3.80	P 4
190042	1.90	4.20	
190048	1.90	4.80	P 5
190049	1.90	4.90	
190057	1.90	5.70	
190058	1.90	5.80	P 6
190064	1.90	6.40	
190068	1.90	6.80	P 7
190072	1.90	7.20	
190078	1.90	7.80	P 8
19008	1.90	8.00	
190088	1.90	8.80	P 9
190089	1.90	8.90	
190098	1.90	9.80	P 10
20002	2.00	2.00	
200025	2.00	2.50	
200026	2.00	2.60	
20003	2.00	3.00	
200035	2.00	3.50	
20004	2.00	4.00	
200045	2.00	4.50	
200046	2.00	4.60	
20005	2.00	5.00	
200055	2.00	5.50	
20006	2.00	6.00	
200065	2.00	6.50	
20007	2.00	7.00	
200075	2.00	7.50	
20008	2.00	8.00	
200085	2.00	8.50	
20009	2.00	9.00	
200094	2.00	9.40	
20010	2.00	10.00	
200105	2.00	10.50	
20011	2.00	11.00	
200115	2.00	11.50	
20012	2.00	12.00	
200125	2.00	12.50	
20013	2.00	13.00	

Part Number	C/S	I.D.	Cross Ref. #
200135	2.00	13.50	
20014	2.00	14.00	
200145	2.00	14.50	
20015	2.00	15.00	
200155	2.00	15.50	
20016	2.00	16.00	
200165	2.00	16.50	
20017	2.00	17.00	
200175	2.00	17.50	
20018	2.00	18.00	
200185	2.00	18.50	
20019	2.00	19.00	
200195	2.00	19.50	
20020	2.00	20.00	
200205	2.00	20.50	
20021	2.00	21.00	
200215	2.00	21.50	
200219	2.00	21.90	S 22.4
20022	2.00	22.00	
200225	2.00	22.50	
20023	2.00	23.00	
200235	2.00	23.50	S 24
20024	2.00	24.00	
200245	2.00	24.50	S 25
20025	2.00	25.00	
200255	2.00	25.50	S 26
20026	2.00	26.00	
200265	2.00	26.50	
20027	2.00	27.00	
200275	2.00	27.50	S 28
20028	2.00	28.00	
200285	2.00	28.50	S 29
20029	2.00	29.00	
200295	2.00	29.50	S 30
20030	2.00	30.00	
200305	2.00	30.50	
20031	2.00	31.00	S 31.5
200315	2.00	31.50	S 32
20032	2.00	32.00	
200325	2.00	32.50	
20033	2.00	33.00	
200335	2.00	33.50	S 34
20034	2.00	34.00	
200345	2.00	34.50	S 35
20035	2.00	35.00	S 35.5
200355	2.00	35.50	S 36
20036	2.00	36.00	
200365	2.00	36.50	
20037	2.00	37.00	
200375	2.00	37.50	S 38
20038	2.00	38.00	

Part Number	C/S	I.D.	Cross Ref. #
20039	2.00	39.00	
200395	2.00	39.50	S 40
20040	2.00	40.00	
20041	2.00	41.00	
200415	2.00	41.50	S 42
20042	2.00	42.00	
20043	2.00	43.00	
200435	2.00	43.50	S 44
20044	2.00	44.00	
200445	2.00	44.50	S 45
20045	2.00	45.00	
200455	2.00	45.50	S 46
20046	2.00	46.00	
20047	2.00	47.00	
200475	2.00	47.50	S 48
20048	2.00	48.00	
20049	2.00	49.00	
200495	2.00	49.50	S 50
20050	2.00	50.00	
20051	2.00	51.00	
20052	2.00	52.00	
200525	2.00	52.50	S 53
20053	2.00	53.00	
20054	2.00	54.00	
200545	2.00	54.50	S 55
20055	2.00	55.00	
200555	2.00	55.50	S 56
20056	2.00	56.00	
20057	2.00	57.00	
20058	2.00	58.00	
20059	2.00	59.00	
200595	2.00	59.50	S 60
20060	2.00	60.00	
20061	2.00	61.00	
20062	2.00	62.00	
200625	2.00	62.50	S 63
20063	2.00	63.00	
20064	2.00	64.00	
200645	2.00	64.50	S 65
20065	2.00	65.00	
20066	2.00	66.00	
200665	2.00	66.50	S 67
20067	2.00	67.00	
20068	2.00	68.00	
20069	2.00	69.00	
200695	2.00	69.50	S 70
20070	2.00	70.00	
200705	2.00	70.50	S 71
20071	2.00	71.00	
20072	2.00	72.00	
20073	2.00	73.00	

Part Number	C/S	I.D.	Cross Ref. #
20074	2.00	74.00	
200745	2.00	74.50	S 75
20075	2.00	75.00	
20076	2.00	76.00	
20077	2.00	77.00	
20078	2.00	78.00	
20079	2.00	79.00	
200795	2.00	79.50	S 80
20080	2.00	80.00	
20081	2.00	81.00	
20082	2.00	82.00	
20083	2.00	83.00	
20084	2.00	84.00	
200845	2.00	84.50	S 85
20085	2.00	85.00	
20086	2.00	86.00	
20087	2.00	87.00	
20088	2.00	88.00	
20089	2.00	89.00	
200895	2.00	89.50	S 90
20090	2.00	90.00	
20091	2.00	91.00	
20092	2.00	92.00	
20093	2.00	93.00	
20094	2.00	94.00	
200945	2.00	94.50	S 95
20095	2.00	95.00	
20096	2.00	96.00	
20097	2.00	97.00	
20098	2.00	98.00	
20099	2.00	99.00	
200995	2.00	99.50	S 100
20100	2.00	100.00	
20102	2.00	102.00	
201045	2.00	104.50	S 105
20105	2.00	105.00	
20109	2.00	109.00	
201095	2.00	109.50	S 110
20110	2.00	110.00	
201115	2.00	111.50	S 112
201145	2.00	114.50	S 115
20115	2.00	115.00	
201195	2.00	119.50	S 120
20120	2.00	120.00	
201245	2.00	124.50	S 125
201256	2.00	125.60	
201295	2.00	129.50	S 130
20130	2.00	130.00	
201315	2.00	131.50	S 132
201345	2.00	134.50	S 135
201395	2.00	139.50	S 140

Part Number	C/S	I.D.	Cross Ref. #
20140	2.00	140.00	
201445	2.00	144.50	S 145
201495	2.00	149.50	S 150
20165	2.00	165.00	
20180	2.00	180.00	
20194	2.00	194.00	
240033	2.40	3.30	
240036	2.40	3.60	
240043	2.40	4.30	
240046	2.40	4.60	
240053	2.40	5.30	
240055	2.40	5.50	
240056	2.40	5.60	
240063	2.40	6.30	
240066	2.40	6.60	
240073	2.40	7.30	
240075	2.40	7.50	
240076	2.40	7.60	
24008	2.40	8.00	
240083	2.40	8.30	
240086	2.40	8.60	
240093	2.40	9.30	
240096	2.40	9.60	
240098	2.40	9.80	P 10A
240103	2.40	10.30	
240105	2.40	10.50	
240106	2.40	10.60	
240108	2.40	10.80	P 11
24011	2.40	11.00	P 11.2
240113	2.40	11.30	
240115	2.40	11.50	
240116	2.40	11.60	
240118	2.40	11.80	P 12
240123	2.40	12.30	P 12.5
240126	2.40	12.60	
240133	2.40	13.30	
240135	2.40	13.50	
240136	2.40	13.60	
240138	2.40	13.80	P 14
240143	2.40	14.30	
240145	2.40	14.50	
240146	2.40	14.60	
240148	2.40	14.80	P 15
240153	2.40	15.30	
240155	2.40	15.50	
240156	2.40	15.60	
240158	2.40	15.80	P 16
240159	2.40	15.90	
240163	2.40	16.30	
240166	2.40	16.60	
240173	2.40	17.30	

# O-Ring Sizing Charts

## Metric O-Ring Sizes

Part Number	C/S	I.D.	Cross Ref. #
240175	2.40	17.50	
240176	2.40	17.60	
240178	2.40	17.80	P 18
240183	2.40	18.30	
240186	2.40	18.60	
240193	2.40	19.30	
240196	2.40	19.60	
240198	2.40	19.80	P 20
240203	2.40	20.30	
240205	2.40	20.50	
240208	2.40	20.80	P 21
240213	2.40	21.30	
240215	2.40	21.50	
240216	2.40	21.60	
240218	2.40	21.80	P 22
240223	2.40	22.30	
240226	2.40	22.60	
240233	2.40	23.30	
240235	2.40	23.50	
240236	2.40	23.60	
240243	2.40	24.30	
240245	2.40	24.50	
240246	2.40	24.60	
24025	2.40	25.00	
240253	2.40	25.30	
240256	2.40	25.60	
240273	2.40	27.30	
240275	2.40	27.50	
240276	2.40	27.60	
240296	2.40	29.60	
240303	2.40	30.30	
240316	2.40	31.60	
240333	2.40	33.30	
240346	2.40	34.60	
240365	2.40	36.50	
240376	2.40	37.60	
240396	2.40	39.60	
240416	2.40	41.60	
240446	2.40	44.60	
240476	2.40	47.60	
240496	2.40	49.60	
240516	2.40	51.60	
240546	2.40	54.60	
240576	2.40	57.60	
240596	2.40	59.60	
240616	2.40	61.60	
240646	2.40	64.60	
240676	2.40	67.60	
240696	2.40	69.60	
25004	2.50	4.00	
250046	2.50	4.60	

Part Number	C/S	I.D.	Cross Ref. #
25005	2.50	5.00	
250055	2.50	5.50	
25006	2.50	6.00	
250065	2.50	6.50	
25007	2.50	7.00	
250075	2.50	7.50	
25008	2.50	8.00	
250085	2.50	8.50	
25009	2.50	9.00	
250095	2.50	9.50	
25010	2.50	10.00	
250105	2.50	10.50	
25011	2.50	11.00	
250115	2.50	11.50	
25012	2.50	12.00	
250125	2.50	12.50	
25013	2.50	13.00	
250135	2.50	13.50	
25014	2.50	14.00	
250145	2.50	14.50	
25015	2.50	15.00	
250155	2.50	15.50	
25016	2.50	16.00	
250165	2.50	16.50	
25017	2.50	17.00	
250175	2.50	17.50	
25018	2.50	18.00	
250185	2.50	18.50	
25019	2.50	19.00	
250195	2.50	19.50	
25020	2.50	20.00	
250205	2.50	20.50	
25021	2.50	21.00	
250215	2.50	21.50	
25022	2.50	22.00	
250225	2.50	22.50	
25023	2.50	23.00	
250235	2.50	23.50	
25024	2.50	24.00	
250245	2.50	24.50	
25025	2.50	25.00	
250255	2.50	25.50	
25026	2.50	26.00	
250265	2.50	26.50	
25027	2.50	27.00	
250275	2.50	27.50	
25028	2.50	28.00	
250285	2.50	28.50	
25029	2.50	29.00	
250295	2.50	29.50	
25030	2.50	30.00	

Part Number	C/S	I.D.	Cross Ref. #
250305	2.50	30.50	
25031	2.50	31.00	
250315	2.50	31.50	
25032	2.50	32.00	
250325	2.50	32.50	
25033	2.50	33.00	
250335	2.50	33.50	
25034	2.50	34.00	
250345	2.50	34.50	
25035	2.50	35.00	
250355	2.50	35.50	
25036	2.50	36.00	
250365	2.50	36.50	
25037	2.50	37.00	
250375	2.50	37.50	
25038	2.50	38.00	
250385	2.50	38.50	
25039	2.50	39.00	
250395	2.50	39.50	
25040	2.50	40.00	
25041	2.50	41.00	
25042	2.50	42.00	
25043	2.50	43.00	
25044	2.50	44.00	
25045	2.50	45.00	
25046	2.50	46.00	
25047	2.50	47.00	
25048	2.50	48.00	
25049	2.50	49.00	
25050	2.50	50.00	
25051	2.50	51.00	
25052	2.50	52.00	
25053	2.50	53.00	
25054	2.50	54.00	
25055	2.50	55.00	
25056	2.50	56.00	
25057	2.50	57.00	
25058	2.50	58.00	
25059	2.50	59.00	
25060	2.50	60.00	
25061	2.50	61.00	
25062	2.50	62.00	
25063	2.50	63.00	
25064	2.50	64.00	
25065	2.50	65.00	
25066	2.50	66.00	
25067	2.50	67.00	
25068	2.50	68.00	
25069	2.50	69.00	
25070	2.50	70.00	
25071	2.50	71.00	

Part Number	C/S	I.D.	Cross Ref. #
25072	2.50	72.00	
25073	2.50	73.00	
25074	2.50	74.00	
25075	2.50	75.00	
25076	2.50	76.00	
25077	2.50	77.00	
25078	2.50	78.00	
25079	2.50	79.00	
25080	2.50	80.00	
25081	2.50	81.00	
25082	2.50	82.00	
25083	2.50	83.00	
25084	2.50	84.00	
25085	2.50	85.00	
25086	2.50	86.00	
25087	2.50	87.00	
25088	2.50	88.00	
25089	2.50	89.00	
25090	2.50	90.00	
25091	2.50	91.00	
25092	2.50	92.00	
25093	2.50	93.00	
25094	2.50	94.00	
25095	2.50	95.00	
25096	2.50	96.00	
25097	2.50	97.00	
25098	2.50	98.00	
25099	2.50	99.00	
25100	2.50	100.00	
25101	2.50	101.00	
25102	2.50	102.00	
25103	2.50	103.00	
25104	2.50	104.00	
25105	2.50	105.00	
25106	2.50	106.00	
25107	2.50	107.00	
25108	2.50	108.00	
25109	2.50	109.00	
25110	2.50	110.00	
25111	2.50	111.00	
25112	2.50	112.00	
25113	2.50	113.00	
25114	2.50	114.00	
25115	2.50	115.00	
25116	2.50	116.00	
25117	2.50	117.00	
25118	2.50	118.00	
25119	2.50	119.00	
25120	2.50	120.00	
25121	2.50	121.00	
25122	2.50	122.00	

Part Number	C/S	I.D.	Cross Ref. #
25123	2.50	123.00	
25124	2.50	124.00	
25125	2.50	125.00	
25126	2.50	126.00	
25127	2.50	127.00	
25128	2.50	128.00	
25129	2.50	129.00	
25130	2.50	130.00	
25131	2.50	131.00	
25132	2.50	132.00	
25133	2.50	133.00	
25134	2.50	134.00	
25135	2.50	135.00	
25136	2.50	136.00	
25137	2.50	137.00	
25138	2.50	138.00	
25139	2.50	139.00	
25140	2.50	140.00	
25141	2.50	141.00	
25142	2.50	142.00	
25143	2.50	143.00	
25144	2.50	144.00	
25145	2.50	145.00	
25146	2.50	146.00	
25147	2.50	147.00	
25148	2.50	148.00	
25149	2.50	149.00	
25150	2.50	150.00	
-102	2.62	1.24	-102
-103	2.62	2.06	-103
-104	2.62	2.84	-104
-105	2.62	3.63	-105
-106	2.62	4.42	-106
-107	2.62	5.23	-107
-108	2.62	6.02	-108
-109	2.62	7.59	-109
-110	2.62	9.19	-110
-111	2.62	10.77	-111
-112	2.62	12.37	-112
-113	2.62	13.94	-113
-114	2.62	15.54	-114
-115	2.62	17.12	-115
-116	2.62	18.72	-116
-117	2.62	20.30	-117
-118	2.62	21.89	-118
-119	2.62	23.47	-119
-120	2.62	25.07	-120
-121	2.62	26.64	-121
-122	2.62	28.24	-122
-123	2.62	29.82	-123
-124	2.62	31.42	-124

Part Number	C/S	I.D.	Cross Ref. #
-125	2.62	32.99	-125
-126	2.62	34.59	-126
-127	2.62	36.17	-127
-128	2.62	37.77	-128
-129	2.62	39.34	-129
-130	2.62	40.94	-130
-131	2.62	42.52	-131
-132	2.62	44.12	-132
-133	2.62	45.69	-133
-134	2.62	47.29	-134
-135	2.62	48.90	-135
-136	2.62	50.47	-136
-137	2.62	52.07	-137
-138	2.62	53.64	-138
-139	2.62	55.25	-139
-140	2.62	56.82	-140
-141	2.62	58.42	-141
-142	2.62	59.99	-142
-143	2.62	61.60	-143
-144	2.62	63.17	-144
-145	2.62	64.77	-145
-146	2.62	66.34	-146
-147	2.62	67.95	-147
-148	2.62	69.52	-148
-149	2.62	71.12	-149
-150	2.62	72.69	-150
-151	2.62	75.87	-151
-152	2.62	82.22	-152
-153	2.62	88.57	-153
-154	2.62	94.92	-154
-155	2.62	101.27	-155
-156	2.62	107.62	-156
-157	2.62	113.97	-157
-158	2.62	120.32	-158
-159	2.62	126.67	-159
-160	2.62	133.02	-160
-161	2.62	139.37	-161
-162	2.62	145.72	-162
-163	2.62	152.07	-163
-164	2.62	158.42	-164
-165	2.62	164.77	-165
-166	2.62	171.12	-166
-167	2.62	177.47	-167
-168	2.62	183.82	-168
-169	2.62	190.17	-169
-170	2.62	196.52	-170
-171	2.62	202.87	-171
-172	2.62	209.22	-172
-173	2.62	215.57	-173
-174	2.62	221.92	-174
-175	2.62	228.27	-175

# O-Ring Sizing Charts

## Metric O-Ring Sizes

Part Number	C/S	I.D.	Cross Ref. #
-176	2.62	234.62	-176
-177	2.62	240.97	-177
-178	2.62	247.32	-178
265014	2.65	14.00	
265015	2.65	15.00	
265016	2.65	16.00	
265017	2.65	17.00	
265018	2.65	18.00	
265019	2.65	19.00	
265020	2.65	20.00	
2650212	2.65	21.20	
2650224	2.65	22.40	
2650236	2.65	23.60	
265025	2.65	25.00	
2650258	2.65	25.80	
2650265	2.65	26.50	
265028	2.65	28.00	
265030	2.65	30.00	
2650315	2.65	31.50	
265032	2.65	32.00	
2650325	2.65	32.50	
2650335	2.65	33.50	
2650345	2.65	34.50	
2650355	2.65	35.50	
2650365	2.65	36.50	
2650375	2.65	37.50	
2650387	2.65	38.70	
300035	3.00	3.50	
30004	3.00	4.00	
300045	3.00	4.50	
30005	3.00	5.00	
300055	3.00	5.50	
30006	3.00	6.00	
300065	3.00	6.50	
30007	3.00	7.00	
300075	3.00	7.50	
30008	3.00	8.00	
300085	3.00	8.50	
30009	3.00	9.00	
300095	3.00	9.50	
30010	3.00	10.00	
300105	3.00	10.50	
30011	3.00	11.00	
300115	3.00	11.50	
30012	3.00	12.00	
300125	3.00	12.50	
30013	3.00	13.00	
300135	3.00	13.50	
30014	3.00	14.00	
300145	3.00	14.50	
30015	3.00	15.00	

Part Number	C/S	I.D.	Cross Ref. #
300155	3.00	15.50	
30016	3.00	16.00	
300165	3.00	16.50	
30017	3.00	17.00	
300175	3.00	17.50	
30018	3.00	18.00	
300182	3.00	18.20	
300185	3.00	18.50	
30019	3.00	19.00	
300192	3.00	19.20	
300195	3.00	19.50	
30020	3.00	20.00	
300205	3.00	20.50	
30021	3.00	21.00	
300215	3.00	21.50	
30022	3.00	22.00	
300222	3.00	22.20	
300225	3.00	22.50	
30023	3.00	23.00	
300235	3.00	23.50	
30024	3.00	24.00	
300242	3.00	24.20	
300245	3.00	24.50	
300246	3.00	24.60	
30025	3.00	25.00	
300252	3.00	25.20	
300255	3.00	25.50	
30026	3.00	26.00	
300262	3.00	26.20	
300265	3.00	26.50	
30027	3.00	27.00	
300275	3.00	27.50	
30028	3.00	28.00	
300285	3.00	28.50	
30029	3.00	29.00	
300292	3.00	29.20	
300295	3.00	29.50	
30030	3.00	30.00	
300302	3.00	30.20	
300305	3.00	30.50	
30031	3.00	31.00	
300315	3.00	31.50	
30032	3.00	32.00	
300322	3.00	32.20	
300325	3.00	32.50	
30033	3.00	33.00	
300335	3.00	33.50	
30034	3.00	34.00	
300342	3.00	34.20	
300345	3.00	34.50	
30035	3.00	35.00	

Part Number	C/S	I.D.	Cross Ref. #
300355	3.00	35.50	
30036	3.00	36.00	
300362	3.00	36.20	
300365	3.00	36.50	
30037	3.00	37.00	
300372	3.00	37.20	
300375	3.00	37.50	
30038	3.00	38.00	
300385	3.00	38.50	
30039	3.00	39.00	
300392	3.00	39.20	
300395	3.00	39.50	
30040	3.00	40.00	
300402	3.00	40.20	
30041	3.00	41.00	
300415	3.00	41.50	
30042	3.00	42.00	
300422	3.00	42.20	
300425	3.00	42.50	
30043	3.00	43.00	
30044	3.00	44.00	
300442	3.00	44.20	
300445	3.00	44.50	
30045	3.00	45.00	
30046	3.00	46.00	
30047	3.00	47.00	
30048	3.00	48.00	
30049	3.00	49.00	
300495	3.00	49.50	
30050	3.00	50.00	
300505	3.00	50.50	
30051	3.00	51.00	
30052	3.00	52.00	
30053	3.00	53.00	
30054	3.00	54.00	
300542	3.00	54.20	
300545	3.00	54.50	
30055	3.00	55.00	
30056	3.00	56.00	
300562	3.00	56.20	
30057	3.00	57.00	
30058	3.00	58.00	
30059	3.00	59.00	
300595	3.00	59.50	
30060	3.00	60.00	
30061	3.00	61.00	
30062	3.00	62.00	
300622	3.00	62.20	
30063	3.00	63.00	
30064	3.00	64.00	
300645	3.00	64.50	

Part Number	C/S	I.D.	Cross Ref. #
30065	3.00	65.00	
30066	3.00	66.00	
30067	3.00	67.00	
30068	3.00	68.00	
30069	3.00	69.00	
30070	3.00	70.00	
30071	3.00	71.00	
30072	3.00	72.00	
30073	3.00	73.00	
30074	3.00	74.00	
30075	3.00	75.00	
30076	3.00	76.00	
30077	3.00	77.00	
30078	3.00	78.00	
30079	3.00	79.00	
30080	3.00	80.00	
30081	3.00	81.00	
30082	3.00	82.00	
30083	3.00	83.00	
30084	3.00	84.00	
300845	3.00	84.50	
30085	3.00	85.00	
30086	3.00	86.00	
30087	3.00	87.00	
30088	3.00	88.00	
30089	3.00	89.00	
300895	3.00	89.50	
30090	3.00	90.00	
30091	3.00	91.00	
30092	3.00	92.00	
30093	3.00	93.00	
30094	3.00	94.00	
300945	3.00	94.50	
30095	3.00	95.00	
30096	3.00	96.00	
30097	3.00	97.00	
30098	3.00	98.00	
30099	3.00	99.00	
300995	3.00	99.50	
30100	3.00	100.00	
30101	3.00	101.00	
30102	3.00	102.00	
30103	3.00	103.00	
30104	3.00	104.00	
301045	3.00	104.50	
30105	3.00	105.00	
30106	3.00	106.00	
30107	3.00	107.00	
30108	3.00	108.00	
30109	3.00	109.00	
301095	3.00	109.50	

Part Number	C/S	I.D.	Cross Ref. #
30110	3.00	110.00	
30111	3.00	111.00	
30112	3.00	112.00	
30113	3.00	113.00	
30114	3.00	114.00	
301145	3.00	114.50	
30115	3.00	115.00	
30116	3.00	116.00	
30117	3.00	117.00	
30118	3.00	118.00	
30119	3.00	119.00	
301195	3.00	119.50	
30120	3.00	120.00	
30121	3.00	121.00	
30122	3.00	122.00	
30123	3.00	123.00	
30124	3.00	124.00	
301245	3.00	124.50	
30125	3.00	125.00	
30126	3.00	126.00	
301265	3.00	126.50	
30127	3.00	127.00	
30128	3.00	128.00	
30129	3.00	129.00	
301295	3.00	129.50	
30130	3.00	130.00	
30131	3.00	131.00	
30132	3.00	132.00	
30133	3.00	133.00	
30134	3.00	134.00	
301345	3.00	134.50	
30135	3.00	135.00	
30136	3.00	136.00	
30137	3.00	137.00	
30138	3.00	138.00	
30139	3.00	139.00	
301395	3.00	139.50	
30140	3.00	140.00	
30141	3.00	141.00	
30142	3.00	142.00	
30143	3.00	143.00	
30144	3.00	144.00	
301445	3.00	144.50	
30145	3.00	145.00	
30146	3.00	146.00	
30147	3.00	147.00	
30148	3.00	148.00	
30149	3.00	149.00	
301495	3.00	149.50	
30150	3.00	150.00	
30151	3.00	151.00	

Part Number	C/S	I.D.	Cross Ref. #
30152	3.00	152.00	
30153	3.00	153.00	
30154	3.00	154.00	
301545	3.00	154.50	
30155	3.00	155.00	
30156	3.00	156.00	
30157	3.00	157.00	
30158	3.00	158.00	
30159	3.00	159.00	
301595	3.00	159.50	
30160	3.00	160.00	
30161	3.00	161.00	
30162	3.00	162.00	
30163	3.00	163.00	
30164	3.00	164.00	
301645	3.00	164.50	
30165	3.00	165.00	
30166	3.00	166.00	
30167	3.00	167.00	
30168	3.00	168.00	
30169	3.00	169.00	
301695	3.00	169.50	
30170	3.00	170.00	
30171	3.00	171.00	
30172	3.00	172.00	
30173	3.00	173.00	
30174	3.00	174.00	
301745	3.00	174.50	
30175	3.00	175.00	
30176	3.00	176.00	
30177	3.00	177.00	
30178	3.00	178.00	
30179	3.00	179.00	
301795	3.00	179.50	
30180	3.00	180.00	
30181	3.00	181.00	
30182	3.00	182.00	
30183	3.00	183.00	
301835	3.00	183.50	
30184	3.00	184.00	
301845	3.00	184.50	
30185	3.00	185.00	
30186	3.00	186.00	
30187	3.00	187.00	
30188	3.00	188.00	
30189	3.00	189.00	
301895	3.00	189.50	
30190	3.00	190.00	
30191	3.00	191.00	
30192	3.00	192.00	
30193	3.00	193.00	

# O-Ring Sizing Charts

## Metric O-Ring Sizes

Part Number	C/S	I.D.	Cross Ref. #
30194	3.00	194.00	
301945	3.00	194.50	
30195	3.00	195.00	
30196	3.00	196.00	
30197	3.00	197.00	
30198	3.00	198.00	
30199	3.00	199.00	
301995	3.00	199.50	
30200	3.00	200.00	
310244	3.10	24.40	G 25
310294	3.10	29.40	G 30
310344	3.10	34.40	G 35
310394	3.10	39.40	G 40
310444	3.10	44.40	G 45
310494	3.10	49.40	G 50
310544	3.10	54.40	G 55
310594	3.10	59.40	G 60
310644	3.10	64.40	G 65
310694	3.10	69.40	G 70
310744	3.10	74.40	G 75
310794	3.10	79.40	G 80
310844	3.10	84.40	G 85
310894	3.10	89.40	G 90
310944	3.10	94.40	G 95
310994	3.10	99.40	G 100
311044	3.10	104.40	G 105
311094	3.10	109.40	G 110
311144	3.10	114.40	G 115
311194	3.10	119.40	G 120
311244	3.10	124.40	G 125
311294	3.10	129.40	G 130
311344	3.10	134.40	G 135
311394	3.10	139.40	G 140
311444	3.10	144.40	G 145
35005	3.50	5.00	
35008	3.50	8.00	
35009	3.50	9.00	
350092	3.50	9.20	
35010	3.50	10.00	
35011	3.50	11.00	
35012	3.50	12.00	
35013	3.50	13.00	
35014	3.50	14.00	
35015	3.50	15.00	
35016	3.50	16.00	
35017	3.50	17.00	
350175	3.50	17.50	
35018	3.50	18.00	
35019	3.50	19.00	
35020	3.50	20.00	
35021	3.50	21.00	

Part Number	C/S	I.D.	Cross Ref. #
350217	3.50	21.70	P 22A
35022	3.50	22.00	
350221	3.50	22.10	P 22.4
35023	3.50	23.00	
350237	3.50	23.70	P 24
35024	3.50	24.00	
350247	3.50	24.70	P 25
35025	3.50	25.00	
350252	3.50	25.20	P 25.5
350257	3.50	25.70	P 26
35026	3.50	26.00	
35027	3.50	27.00	
350277	3.50	27.70	P 28
35028	3.50	28.00	
350287	3.50	28.70	P 29
35029	3.50	29.00	
350292	3.50	29.20	P 29.5
350297	3.50	29.70	P 30
35030	3.50	30.00	
350305	3.50	30.50	
350307	3.50	30.70	P 31
35031	3.50	31.00	
350312	3.50	31.20	P 31.5
350317	3.50	31.70	P 32
35032	3.50	32.00	
35033	3.50	33.00	
350337	3.50	33.70	P 34
35034	3.50	34.00	
350347	3.50	34.70	P 35
35035	3.50	35.00	
350352	3.50	35.20	P 35.5
350357	3.50	35.70	P 36
35036	3.50	36.00	
35037	3.50	37.00	
350377	3.50	37.70	P 38
35038	3.50	38.00	
350387	3.50	38.70	P 39
35039	3.50	39.00	
350397	3.50	39.70	P 40
35040	3.50	40.00	
350407	3.50	40.70	P 41
35041	3.50	41.00	
350417	3.50	41.70	P 42
35042	3.50	42.00	
35043	3.50	43.00	
350437	3.50	43.70	P 44
35044	3.50	44.00	
350447	3.50	44.70	P 45
35045	3.50	45.00	
350457	3.50	45.70	P 46
35046	3.50	46.00	

Part Number	C/S	I.D.	Cross Ref. #
35047	3.50	47.00	
350477	3.50	47.70	P 48
35048	3.50	48.00	
350487	3.50	48.70	P 49
35049	3.50	49.00	
350497	3.50	49.70	P 50
35050	3.50	50.00	
35051	3.50	51.00	
35052	3.50	52.00	
35053	3.50	53.00	
35054	3.50	54.00	
35055	3.50	55.00	
35056	3.50	56.00	
35057	3.50	57.00	
35058	3.50	58.00	
35059	3.50	59.00	
35060	3.50	60.00	
35061	3.50	61.00	
35062	3.50	62.00	
35063	3.50	63.00	
35064	3.50	64.00	
35065	3.50	65.00	
35066	3.50	66.00	
35067	3.50	67.00	
35068	3.50	68.00	
35069	3.50	69.00	
35070	3.50	70.00	
35071	3.50	71.00	
35072	3.50	72.00	
35073	3.50	73.00	
35074	3.50	74.00	
35075	3.50	75.00	
35076	3.50	76.00	
35077	3.50	77.00	
35078	3.50	78.00	
35079	3.50	79.00	
35080	3.50	80.00	
35081	3.50	81.00	
35082	3.50	82.00	
35083	3.50	83.00	
35084	3.50	84.00	
35085	3.50	85.00	
35086	3.50	86.00	
35087	3.50	87.00	
35088	3.50	88.00	
35089	3.50	89.00	
35090	3.50	90.00	
35091	3.50	91.00	
35092	3.50	92.00	
35093	3.50	93.00	
35094	3.50	94.00	



Part Number	C/S	I.D.	Cross Ref. #
35095	3.50	95.00	
35096	3.50	96.00	
35097	3.50	97.00	
35098	3.50	98.00	
35099	3.50	99.00	
35100	3.50	100.00	
35101	3.50	101.00	
35102	3.50	102.00	
35103	3.50	103.00	
35104	3.50	104.00	
35105	3.50	105.00	
35106	3.50	106.00	
35107	3.50	107.00	
35108	3.50	108.00	
35109	3.50	109.00	
35110	3.50	110.00	
35111	3.50	111.00	
35112	3.50	112.00	
35113	3.50	113.00	
35114	3.50	114.00	
35115	3.50	115.00	
35116	3.50	116.00	
35117	3.50	117.00	
35118	3.50	118.00	
35119	3.50	119.00	
35120	3.50	120.00	
35121	3.50	121.00	
35122	3.50	122.00	
35123	3.50	123.00	
35124	3.50	124.00	
35125	3.50	125.00	
35126	3.50	126.00	
35127	3.50	127.00	
35128	3.50	128.00	
35129	3.50	129.00	
35130	3.50	130.00	
35131	3.50	131.00	
35132	3.50	132.00	
35133	3.50	133.00	
35134	3.50	134.00	
35135	3.50	135.00	
35136	3.50	136.00	
35137	3.50	137.00	
35138	3.50	138.00	
35139	3.50	139.00	
35140	3.50	140.00	
35141	3.50	141.00	
35142	3.50	142.00	
35143	3.50	143.00	
35144	3.50	144.00	
35145	3.50	145.00	

Part Number	C/S	I.D.	Cross Ref. #
35146	3.50	146.00	
35147	3.50	147.00	
35148	3.50	148.00	
35149	3.50	149.00	
35150	3.50	150.00	
35151	3.50	151.00	
35152	3.50	152.00	
35153	3.50	153.00	
35154	3.50	154.00	
35155	3.50	155.00	
35156	3.50	156.00	
35157	3.50	157.00	
35158	3.50	158.00	
35159	3.50	159.00	
35160	3.50	160.00	
35161	3.50	161.00	
35162	3.50	162.00	
35163	3.50	163.00	
35164	3.50	164.00	
35165	3.50	165.00	
35166	3.50	166.00	
35167	3.50	167.00	
35168	3.50	168.00	
35169	3.50	169.00	
35170	3.50	170.00	
35171	3.50	171.00	
35172	3.50	172.00	
35173	3.50	173.00	
35174	3.50	174.00	
35175	3.50	175.00	
35176	3.50	176.00	
35177	3.50	177.00	
35178	3.50	178.00	
35179	3.50	179.00	
35180	3.50	180.00	
35181	3.50	181.00	
35182	3.50	182.00	
35183	3.50	183.00	
35184	3.50	184.00	
35185	3.50	185.00	
35186	3.50	186.00	
35187	3.50	187.00	
35188	3.50	188.00	
35189	3.50	189.00	
35190	3.50	190.00	
35191	3.50	191.00	
35192	3.50	192.00	
35193	3.50	193.00	
35194	3.50	194.00	
35195	3.50	195.00	
35196	3.50	196.00	

Part Number	C/S	I.D.	Cross Ref. #
35197	3.50	197.00	
35198	3.50	198.00	
35199	3.50	199.00	
35200	3.50	200.00	
-201	3.53	4.34	-201
-202	3.53	5.94	-202
-203	3.53	7.52	-203
-204	3.53	9.12	-204
-205	3.53	10.69	-205
-206	3.53	12.29	-206
-207	3.53	13.87	-207
-208	3.53	15.47	-208
-209	3.53	17.04	-209
-210	3.53	18.64	-210
-211	3.53	20.22	-211
-212	3.53	21.82	-212
-213	3.53	23.39	-213
-214	3.53	24.99	-214
-215	3.53	26.57	-215
-216	3.53	28.17	-216
-217	3.53	29.74	-217
-218	3.53	31.34	-218
-219	3.53	32.92	-219
-220	3.53	34.52	-220
-221	3.53	36.09	-221
-222	3.53	37.69	-222
-223	3.53	40.87	-223
-224	3.53	44.04	-224
-225	3.53	47.22	-225
-226	3.53	50.39	-226
-227	3.53	53.57	-227
-228	3.53	56.74	-228
-229	3.53	59.92	-229
-230	3.53	63.09	-230
-231	3.53	66.27	-231
-232	3.53	69.44	-232
-233	3.53	72.62	-233
-234	3.53	75.79	-234
-235	3.53	78.97	-235
-236	3.53	82.14	-236
-237	3.53	85.32	-237
-238	3.53	88.49	-238
-239	3.53	91.67	-239
-240	3.53	94.84	-240
-241	3.53	98.02	-241
-242	3.53	101.19	-242
-243	3.53	104.37	-243
-244	3.53	107.54	-244
-245	3.53	110.72	-245
-246	3.53	113.89	-246
-247	3.53	117.07	-247

# O-Ring Sizing Charts

## Metric O-Ring Sizes

Part Number	C/S	I.D.	Cross Ref. #
-248	3.53	120.24	-248
-249	3.53	123.42	-249
-250	3.53	126.59	-250
-251	3.53	129.77	-251
-252	3.53	132.94	-252
-253	3.53	136.12	-253
-254	3.53	139.29	-254
-255	3.53	142.47	-255
-256	3.53	145.64	-256
-257	3.53	148.82	-257
-258	3.53	151.99	-258
-259	3.53	158.34	-259
-260	3.53	164.69	-260
-261	3.53	171.04	-261
-262	3.53	177.39	-262
-263	3.53	183.74	-263
-264	3.53	190.09	-264
-265	3.53	196.44	-265
-266	3.53	202.79	-266
-267	3.53	209.14	-267
-268	3.53	215.49	-268
-269	3.53	221.84	-269
-270	3.53	228.19	-270
-271	3.53	234.54	-271
-272	3.53	240.89	-272
-273	3.53	247.24	-273
-274	3.53	253.59	-274
-275	3.53	266.29	-275
-276	3.53	278.99	-276
-277	3.53	291.69	-277
-278	3.53	304.39	-278
-279	3.53	329.79	-279
-280	3.53	355.19	-280
-281	3.53	380.59	-281
-282	3.53	405.26	-282
-283	3.53	430.68	-283
-284	3.53	456.06	-284
360183	3.60	18.30	
360198	3.60	19.80	
360213	3.60	21.30	
36023	3.60	23.00	
360246	3.60	24.60	
360262	3.60	26.20	
360278	3.60	27.80	
360293	3.60	29.30	
360308	3.60	30.80	
360325	3.60	32.50	
360341	3.60	34.10	
360356	3.60	35.60	
360373	3.60	37.30	
360434	3.60	43.40	

Part Number	C/S	I.D.	Cross Ref. #
40004	4.00	4.00	
40005	4.00	5.00	
40006	4.00	6.00	
40007	4.00	7.00	
40008	4.00	8.00	
40009	4.00	9.00	
40010	4.00	10.00	
40011	4.00	11.00	
40012	4.00	12.00	
40013	4.00	13.00	
40014	4.00	14.00	
400145	4.00	14.50	V 15
40015	4.00	15.00	
40016	4.00	16.00	
40017	4.00	17.00	
40018	4.00	18.00	
40019	4.00	19.00	
40020	4.00	20.00	
40021	4.00	21.00	
40022	4.00	22.00	
40023	4.00	23.00	
400235	4.00	23.50	V 24
40024	4.00	24.00	
40025	4.00	25.00	
40026	4.00	26.00	
40027	4.00	27.00	
40028	4.00	28.00	
40029	4.00	29.00	
40030	4.00	30.00	
40031	4.00	31.00	
40032	4.00	32.00	
40033	4.00	33.00	
400335	4.00	33.50	V 34
40034	4.00	34.00	
40035	4.00	35.00	
400355	4.00	35.50	V 36
40036	4.00	36.00	
40037	4.00	37.00	
40038	4.00	38.00	
40039	4.00	39.00	
400395	4.00	39.50	V 40
40040	4.00	40.00	
40041	4.00	41.00	
40042	4.00	42.00	
40043	4.00	43.00	
40044	4.00	44.00	
40045	4.00	45.00	
40046	4.00	46.00	
40047	4.00	47.00	
40048	4.00	48.00	
40049	4.00	49.00	

Part Number	C/S	I.D.	Cross Ref. #
40050	4.00	50.00	
40051	4.00	51.00	
40052	4.00	52.00	
40053	4.00	53.00	
40054	4.00	54.00	
400545	4.00	54.50	V 55
40055	4.00	55.00	
40056	4.00	56.00	
40057	4.00	57.00	
40058	4.00	58.00	
40059	4.00	59.00	
40060	4.00	60.00	
40061	4.00	61.00	
40062	4.00	62.00	
40063	4.00	63.00	
40064	4.00	64.00	
40065	4.00	65.00	
40066	4.00	66.00	
40067	4.00	67.00	
40068	4.00	68.00	
40069	4.00	69.00	V 70
40070	4.00	70.00	
40071	4.00	71.00	
40072	4.00	72.00	
40073	4.00	73.00	
40074	4.00	74.00	
40075	4.00	75.00	
40076	4.00	76.00	
40077	4.00	77.00	
40078	4.00	78.00	
40079	4.00	79.00	
40080	4.00	80.00	
40081	4.00	81.00	
40082	4.00	82.00	
40083	4.00	83.00	
40084	4.00	84.00	V 85
40085	4.00	85.00	
40086	4.00	86.00	
40087	4.00	87.00	
40088	4.00	88.00	
40089	4.00	89.00	
40090	4.00	90.00	
40091	4.00	91.00	
40092	4.00	92.00	
40093	4.00	93.00	
40094	4.00	94.00	
40109	4.00	109.00	
40110	4.00	110.00	
40111	4.00	111.00	
40112	4.00	112.00	
40113	4.00	113.00	

Part Number	C/S	I.D.	Cross Ref. #
40114	4.00	114.00	
40115	4.00	115.00	
40116	4.00	116.00	
40117	4.00	117.00	
40118	4.00	118.00	
40119	4.00	119.00	V 120
40120	4.00	120.00	
40121	4.00	121.00	
40122	4.00	122.00	
40123	4.00	123.00	
40124	4.00	124.00	
40125	4.00	125.00	
40126	4.00	126.00	
40127	4.00	127.00	
40128	4.00	128.00	
40129	4.00	129.00	
40130	4.00	130.00	
40131	4.00	131.00	
40132	4.00	132.00	
40133	4.00	133.00	
40134	4.00	134.00	
40135	4.00	135.00	
40136	4.00	136.00	
40137	4.00	137.00	
40138	4.00	138.00	
40139	4.00	139.00	
40140	4.00	140.00	
40141	4.00	141.00	
40142	4.00	142.00	
40143	4.00	143.00	
40144	4.00	144.00	
40145	4.00	145.00	
40146	4.00	146.00	
40147	4.00	147.00	
40148	4.00	148.00	
401485	4.00	148.50	V 150
40149	4.00	149.00	
40150	4.00	150.00	
40151	4.00	151.00	
40152	4.00	152.00	
40153	4.00	153.00	
40154	4.00	154.00	
40155	4.00	155.00	
40156	4.00	156.00	
40157	4.00	157.00	
40158	4.00	158.00	
40159	4.00	159.00	
40160	4.00	160.00	
40161	4.00	161.00	
40162	4.00	162.00	
40163	4.00	163.00	

Part Number	C/S	I.D.	Cross Ref. #
40164	4.00	164.00	
40165	4.00	165.00	
40166	4.00	166.00	
40167	4.00	167.00	
40168	4.00	168.00	
40169	4.00	169.00	
40170	4.00	170.00	
40171	4.00	171.00	
40172	4.00	172.00	
40173	4.00	173.00	V175
40174	4.00	174.00	
40175	4.00	175.00	
40176	4.00	176.00	
40177	4.00	177.00	
40178	4.00	178.00	
40179	4.00	179.00	
40180	4.00	180.00	
40181	4.00	181.00	
40182	4.00	182.00	
40183	4.00	183.00	
40184	4.00	184.00	
40185	4.00	185.00	
40186	4.00	186.00	
40187	4.00	187.00	
40188	4.00	188.00	
40189	4.00	189.00	
40190	4.00	190.00	
40191	4.00	191.00	
40192	4.00	192.00	
40193	4.00	193.00	
40194	4.00	194.00	
40195	4.00	195.00	
40196	4.00	196.00	
40197	4.00	197.00	
40198	4.00	198.00	
40199	4.00	199.00	
40200	4.00	200.00	
40201	4.00	201.00	
40202	4.00	202.00	
40203	4.00	203.00	
40204	4.00	204.00	
40205	4.00	205.00	
40206	4.00	206.00	
40207	4.00	207.00	
40208	4.00	208.00	
40209	4.00	209.00	
40210	4.00	210.00	
45006	4.50	6.00	
45008	4.50	8.00	
45009	4.50	9.00	
45010	4.50	10.00	

Part Number	C/S	I.D.	Cross Ref. #
45011	4.50	11.00	
45012	4.50	12.00	
45013	4.50	13.00	
45015	4.50	15.00	
45016	4.50	16.00	
45017	4.50	17.00	
45018	4.50	18.00	
45019	4.50	19.00	
45020	4.50	20.00	
45021	4.50	21.00	
45022	4.50	22.00	
45023	4.50	23.00	
45024	4.50	24.00	
45025	4.50	25.00	
45026	4.50	26.00	
45028	4.50	28.00	
45029	4.50	29.00	
45030	4.50	30.00	
45031	4.50	31.00	
45032	4.50	32.00	
45033	4.50	33.00	
45034	4.50	34.00	
45035	4.50	35.00	
45036	4.50	36.00	
45037	4.50	37.00	
45038	4.50	38.00	
45039	4.50	39.00	
45040	4.50	40.00	
45041	4.50	41.00	
45042	4.50	42.00	
45043	4.50	43.00	
45044	4.50	44.00	
45045	4.50	45.00	
45046	4.50	46.00	
45047	4.50	47.00	
45048	4.50	48.00	
45049	4.50	49.00	
45050	4.50	50.00	
45051	4.50	51.00	
45053	4.50	53.00	
45056	4.50	56.00	
45057	4.50	57.00	
45060	4.50	60.00	
45061	4.50	61.00	
45062	4.50	62.00	
45063	4.50	63.00	
45064	4.50	64.00	
45065	4.50	65.00	
45066	4.50	66.00	
45068	4.50	68.00	
45069	4.50	69.00	

# O-Ring Sizing Charts

## Metric O-Ring Sizes

Part Number	C/S	I.D.	Cross Ref. #
45070	4.50	70.00	
45071	4.50	71.00	
45073	4.50	73.00	
45074	4.50	74.00	
45075	4.50	75.00	
45076	4.50	76.00	
45080	4.50	80.00	
45081	4.50	81.00	
45083	4.50	83.00	
45085	4.50	85.00	
45086	4.50	86.00	
45089	4.50	89.00	
45090	4.50	90.00	
45092	4.50	92.00	
45095	4.50	95.00	
45098	4.50	98.00	
45100	4.50	100.00	
45101	4.50	101.00	
45105	4.50	105.00	
45106	4.50	106.00	
45110	4.50	110.00	
45115	4.50	115.00	
45118	4.50	118.00	
45120	4.50	120.00	
45122	4.50	122.00	
45124	4.50	124.00	
45126	4.50	126.00	
45128	4.50	128.00	
45130	4.50	130.00	
45137	4.50	137.00	
45140	4.50	140.00	
45150	4.50	150.00	
45153	4.50	153.00	
45155	4.50	155.00	
45157	4.50	157.00	
45160	4.50	160.00	
45165	4.50	165.00	
50004	5.00	4.00	
50005	5.00	5.00	
50006	5.00	6.00	
50007	5.00	7.00	
50008	5.00	8.00	
50009	5.00	9.00	
50010	5.00	10.00	
50011	5.00	11.00	
50012	5.00	12.00	
50013	5.00	13.00	
50014	5.00	14.00	
50015	5.00	15.00	
50016	5.00	16.00	
50017	5.00	17.00	

Part Number	C/S	I.D.	Cross Ref. #
50018	5.00	18.00	
50019	5.00	19.00	
50020	5.00	20.00	
50021	5.00	21.00	
50022	5.00	22.00	
50023	5.00	23.00	
50024	5.00	24.00	
50025	5.00	25.00	
50026	5.00	26.00	
50027	5.00	27.00	
50028	5.00	28.00	
50029	5.00	29.00	
50030	5.00	30.00	
50031	5.00	31.00	
50032	5.00	32.00	
50033	5.00	33.00	
50034	5.00	34.00	
50035	5.00	35.00	
50036	5.00	36.00	
50037	5.00	37.00	
50038	5.00	38.00	
50039	5.00	39.00	
50040	5.00	40.00	
50041	5.00	41.00	
50042	5.00	42.00	
50043	5.00	43.00	
50044	5.00	44.00	
50045	5.00	45.00	
50046	5.00	46.00	
50047	5.00	47.00	
50048	5.00	48.00	
50049	5.00	49.00	
50050	5.00	50.00	
50051	5.00	51.00	
50052	5.00	52.00	
50053	5.00	53.00	
50054	5.00	54.00	
50055	5.00	55.00	
50056	5.00	56.00	
50057	5.00	57.00	
50058	5.00	58.00	
50059	5.00	59.00	
50060	5.00	60.00	
50061	5.00	61.00	
50062	5.00	62.00	
50063	5.00	63.00	
50064	5.00	64.00	
50065	5.00	65.00	
50066	5.00	66.00	
50067	5.00	67.00	
50068	5.00	68.00	

Part Number	C/S	I.D.	Cross Ref. #
50069	5.00	69.00	
50070	5.00	70.00	
50071	5.00	71.00	
50072	5.00	72.00	
50073	5.00	73.00	
50074	5.00	74.00	
50075	5.00	75.00	
50076	5.00	76.00	
50077	5.00	77.00	
50078	5.00	78.00	
50079	5.00	79.00	
50080	5.00	80.00	
50081	5.00	81.00	
50082	5.00	82.00	
50083	5.00	83.00	
50084	5.00	84.00	
50085	5.00	85.00	
50086	5.00	86.00	
50087	5.00	87.00	
50088	5.00	88.00	
50089	5.00	89.00	
50090	5.00	90.00	
50091	5.00	91.00	
50092	5.00	92.00	
50093	5.00	93.00	
50094	5.00	94.00	
50095	5.00	95.00	
50096	5.00	96.00	
50097	5.00	97.00	
50098	5.00	98.00	
50099	5.00	99.00	
50100	5.00	100.00	
50101	5.00	101.00	
50102	5.00	102.00	
50103	5.00	103.00	
50104	5.00	104.00	
50105	5.00	105.00	
50106	5.00	106.00	
50107	5.00	107.00	
50108	5.00	108.00	
50109	5.00	109.00	
50110	5.00	110.00	
50111	5.00	111.00	
50112	5.00	112.00	
50113	5.00	113.00	
50114	5.00	114.00	
50115	5.00	115.00	
50116	5.00	116.00	
50117	5.00	117.00	
50118	5.00	118.00	
50119	5.00	119.00	

Part Number	C/S	I.D.	Cross Ref. #
50120	5.00	120.00	
50121	5.00	121.00	
50122	5.00	122.00	
50123	5.00	123.00	
50124	5.00	124.00	
50125	5.00	125.00	
50126	5.00	126.00	
50127	5.00	127.00	
50128	5.00	128.00	
50129	5.00	129.00	
50130	5.00	130.00	
50131	5.00	131.00	
50132	5.00	132.00	
50133	5.00	133.00	
50134	5.00	134.00	
50135	5.00	135.00	
50136	5.00	136.00	
50137	5.00	137.00	
50138	5.00	138.00	
50139	5.00	139.00	
50140	5.00	140.00	
50141	5.00	141.00	
50142	5.00	142.00	
50143	5.00	143.00	
50144	5.00	144.00	
50145	5.00	145.00	
50146	5.00	146.00	
50147	5.00	147.00	
50148	5.00	148.00	
50149	5.00	149.00	
50150	5.00	150.00	
50151	5.00	151.00	
50152	5.00	152.00	
50153	5.00	153.00	
50154	5.00	154.00	
50155	5.00	155.00	
50156	5.00	156.00	
50157	5.00	157.00	
50158	5.00	158.00	
50159	5.00	159.00	
50160	5.00	160.00	
50161	5.00	161.00	
50162	5.00	162.00	
50163	5.00	163.00	
50164	5.00	164.00	
50165	5.00	165.00	
50166	5.00	166.00	
50167	5.00	167.00	
50168	5.00	168.00	
50169	5.00	169.00	
50170	5.00	170.00	

Part Number	C/S	I.D.	Cross Ref. #
50171	5.00	171.00	
50172	5.00	172.00	
50173	5.00	173.00	
50174	5.00	174.00	
50175	5.00	175.00	
50176	5.00	176.00	
50177	5.00	177.00	
50178	5.00	178.00	
50179	5.00	179.00	
50180	5.00	180.00	
50181	5.00	181.00	
50182	5.00	182.00	
50183	5.00	183.00	
50184	5.00	184.00	
50185	5.00	185.00	
50186	5.00	186.00	
50187	5.00	187.00	
50188	5.00	188.00	
50189	5.00	189.00	
50190	5.00	190.00	
50191	5.00	191.00	
50192	5.00	192.00	
50193	5.00	193.00	
50194	5.00	194.00	
50195	5.00	195.00	
50196	5.00	196.00	
50197	5.00	197.00	
50198	5.00	198.00	
50199	5.00	199.00	
50200	5.00	200.00	
50201	5.00	201.00	
50202	5.00	202.00	
50203	5.00	203.00	
50204	5.00	204.00	
50205	5.00	205.00	
50206	5.00	206.00	
50207	5.00	207.00	
50208	5.00	208.00	
50209	5.00	209.00	
50210	5.00	210.00	
50211	5.00	211.00	
50212	5.00	212.00	
50213	5.00	213.00	
50214	5.00	214.00	
50215	5.00	215.00	
50216	5.00	216.00	
50217	5.00	217.00	
50218	5.00	218.00	
50219	5.00	219.00	
50220	5.00	220.00	
50221	5.00	221.00	

Part Number	C/S	I.D.	Cross Ref. #
50222	5.00	222.00	
50223	5.00	223.00	
50224	5.00	224.00	
50225	5.00	225.00	
50226	5.00	226.00	
50227	5.00	227.00	
50228	5.00	228.00	
50229	5.00	229.00	
50230	5.00	230.00	
50231	5.00	231.00	
50232	5.00	232.00	
50233	5.00	233.00	
50234	5.00	234.00	
50235	5.00	235.00	
50236	5.00	236.00	
50237	5.00	237.00	
50238	5.00	238.00	
50239	5.00	239.00	
50240	5.00	240.00	
50241	5.00	241.00	
50242	5.00	242.00	
50243	5.00	243.00	
50244	5.00	244.00	
50245	5.00	245.00	
50246	5.00	246.00	
50247	5.00	247.00	
50248	5.00	248.00	
50249	5.00	249.00	
50250	5.00	250.00	
53040	5.30	40.00	
530412	5.30	41.20	
530414	5.30	41.40	
530425	5.30	42.50	
530437	5.30	43.70	
53045	5.30	45.00	
530462	5.30	46.20	
530475	5.30	47.50	
530487	5.30	48.70	
53050	5.30	50.00	
530515	5.30	51.50	
53053	5.30	53.00	
530544	5.30	54.40	
530545	5.30	54.50	
53056	5.30	56.00	
53058	5.30	58.00	
53060	5.30	60.00	
530615	5.30	61.50	
53063	5.30	63.00	
53065	5.30	65.00	
53067	5.30	67.00	
53069	5.30	69.00	

# O-Ring Sizing Charts

## Metric O-Ring Sizes

Part Number	C/S	I.D.	Cross Ref. #
53071	5.30	71.00	
53073	5.30	73.00	
53075	5.30	75.00	
530775	5.30	77.50	
53080	5.30	80.00	
530825	5.30	82.50	
53085	5.30	85.00	
530875	5.30	87.50	
53090	5.30	90.00	
530925	5.30	92.50	
53095	5.30	95.00	
530975	5.30	97.50	
53100	5.30	100.00	
53103	5.30	103.00	
53106	5.30	106.00	
53109	5.30	109.00	
53112	5.30	112.00	
53115	5.30	115.00	
53118	5.30	118.00	
53122	5.30	122.00	
53125	5.30	125.00	
53128	5.30	128.00	
53132	5.30	132.00	
53136	5.30	136.00	
53140	5.30	140.00	
53145	5.30	145.00	
53150	5.30	150.00	
53155	5.30	155.00	
53160	5.30	160.00	
53165	5.30	165.00	
53170	5.30	170.00	
53175	5.30	175.00	
53180	5.30	180.00	
53185	5.30	185.00	
53190	5.30	190.00	
53195	5.30	195.00	
53200	5.30	200.00	
-309	5.33	10.46	-309
-310	5.33	12.07	-310
-311	5.33	13.64	-311
-312	5.33	15.24	-312
-313	5.33	16.81	-313
-314	5.33	18.42	-314
-315	5.33	19.99	-315
-316	5.33	21.59	-316
-317	5.33	23.16	-317
-318	5.33	24.77	-318
-319	5.33	26.34	-319
-320	5.33	27.94	-320
-321	5.33	29.51	-321
-322	5.33	31.12	-322

Part Number	C/S	I.D.	Cross Ref. #
-323	5.33	32.69	-323
-324	5.33	34.29	-324
-325	5.33	37.47	-325
-326	5.33	40.64	-326
-327	5.33	43.82	-327
-328	5.33	46.99	-328
-329	5.33	50.17	-329
-330	5.33	53.34	-330
-331	5.33	56.52	-331
-332	5.33	59.69	-332
-333	5.33	62.87	-333
-334	5.33	66.04	-334
-335	5.33	69.22	-335
-336	5.33	72.39	-336
-337	5.33	75.57	-337
-338	5.33	78.74	-338
-339	5.33	81.92	-339
-340	5.33	85.09	-340
-341	5.33	88.27	-341
-342	5.33	91.44	-342
-343	5.33	94.62	-343
-344	5.33	97.79	-344
-345	5.33	100.97	-345
-346	5.33	104.14	-346
-347	5.33	107.32	-347
-348	5.33	110.49	-348
-349	5.33	113.67	-349
-350	5.33	116.84	-350
-351	5.33	120.02	-351
-352	5.33	123.19	-352
-353	5.33	126.37	-353
-354	5.33	129.54	-354
-355	5.33	132.72	-355
-356	5.33	135.89	-356
-357	5.33	139.07	-357
-358	5.33	142.24	-358
-359	5.33	145.42	-359
-360	5.33	148.59	-360
-361	5.33	151.77	-361
-362	5.33	158.12	-362
-363	5.33	164.47	-363
-364	5.33	170.82	-364
-365	5.33	177.17	-365
-366	5.33	183.52	-366
-367	5.33	189.87	-367
-368	5.33	196.22	-368
-369	5.33	202.57	-369
-370	5.33	208.92	-370
-371	5.33	215.27	-371
-372	5.33	221.62	-372
-373	5.33	227.97	-373

Part Number	C/S	I.D.	Cross Ref. #
-374	5.33	234.32	-374
-375	5.33	240.67	-375
-376	5.33	247.02	-376
-377	5.33	253.37	-377
-378	5.33	266.07	-378
-379	5.33	278.77	-379
-380	5.33	291.47	-380
-381	5.33	304.17	-381
-382	5.33	329.57	-382
-383	5.33	354.97	-383
-384	5.33	380.37	-384
-385	5.33	405.26	-385
-386	5.33	430.66	-386
-387	5.33	456.06	-387
-388	5.33	481.38	-388
-389	5.33	506.78	-389
-390	5.33	532.18	-390
-391	5.33	557.58	-391
-392	5.33	582.68	-392
-393	5.33	608.08	-393
-394	5.33	633.48	-394
-395	5.33	658.88	-395
570242	5.70	24.20	
570352	5.70	35.20	
570362	5.70	36.20	
570372	5.70	37.20	
570392	5.70	39.20	
570412	5.70	41.20	
570442	5.70	44.20	
570443	5.70	44.30	
570452	5.70	45.20	
570453	5.70	45.30	
570472	5.70	47.20	
570476	5.70	47.60	P 48A
570492	5.70	49.20	
570493	5.70	49.30	
570496	5.70	49.60	P 50A
570512	5.70	51.20	
570516	5.70	51.60	P 52
570522	5.70	52.20	
570523	5.70	52.30	
570525	5.70	52.50	
570526	5.70	52.60	P 53
570530	5.70	53.00	
570542	5.70	54.20	
570543	5.70	54.30	
570546	5.70	54.60	P 55
570552	5.70	55.20	
570553	5.70	55.30	
570556	5.70	55.60	P 56
570572	5.70	57.20	

Part Number	C/S	I.D.	Cross Ref. #
570576	5.70	57.60	P 58
570592	5.70	59.20	
570593	5.70	59.30	
570596	5.70	59.60	P 60
570597	5.70	59.70	
570612	5.70	61.20	
570616	5.70	61.60	P 62
57062	5.70	62.00	
570622	5.70	62.20	
570623	5.70	62.30	
570626	5.70	62.60	P 63
57064	5.70	64.00	
570642	5.70	64.20	
570643	5.70	64.30	
570646	5.70	64.60	P 65
570666	5.70	66.60	P 67
570672	5.70	67.20	
57069	5.70	69.00	
570692	5.70	69.20	
570693	5.70	69.30	
570696	5.70	69.60	P 70
570702	5.70	70.20	
570706	5.70	70.60	P 71
570712	5.70	71.20	
570722	5.70	72.20	
570723	5.70	72.30	
57074	5.70	74.00	
570742	5.70	74.20	
570743	5.70	74.30	
570746	5.70	74.60	P 75
570772	5.70	77.20	
57079	5.70	79.00	
570792	5.70	79.20	
570793	5.70	79.30	
570796	5.70	79.60	P 80
570812	5.70	81.20	
570822	5.70	82.20	
570842	5.70	84.20	
570846	5.70	84.60	P 85
570872	5.70	87.20	
570891	5.70	89.10	
570892	5.70	89.20	
570893	5.70	89.30	
570896	5.70	89.60	P 90
570922	5.70	92.20	
570942	5.70	94.20	
570946	5.70	94.60	P 95
570966	5.70	96.60	
570992	5.70	99.20	
570996	5.70	99.60	P 100
571016	5.70	101.60	P 102

Part Number	C/S	I.D.	Cross Ref. #
571046	5.70	104.60	P 105
571092	5.70	109.20	
571093	5.70	109.30	
571096	5.70	109.60	P 110
571116	5.70	111.60	P 112
571142	5.70	114.20	
571143	5.70	114.30	
571146	5.70	114.60	P 115
571192	5.70	119.20	
571196	5.70	119.60	P 120
571246	5.70	124.60	P 125
571292	5.70	129.20	
571296	5.70	129.60	P 130
571316	5.70	131.60	P 132
571342	5.70	134.20	
571346	5.70	134.60	P 135
571392	5.70	139.20	
571393	5.70	139.30	
571396	5.70	139.60	P 140
571442	5.70	144.20	
571446	5.70	144.60	P 145
571492	5.70	149.20	
571493	5.70	149.30	G 150
571496	5.70	149.60	P 150
571543	5.70	154.30	G 155
571593	5.70	159.30	G 160
571642	5.70	164.20	
571643	5.70	164.30	G 165
571693	5.70	169.30	G 170
571742	5.70	174.20	
571743	5.70	174.30	G 175
571793	5.70	179.30	G 180
571843	5.70	184.30	G 185
571892	5.70	189.20	
571893	5.70	189.30	G 190
571942	5.70	194.20	
571943	5.70	194.30	G 195
571992	5.70	199.20	
571993	5.70	199.30	G 200
572042	5.70	204.20	
572092	5.70	209.20	
572093	5.70	209.30	G 210
572193	5.70	219.30	G 220
572293	5.70	229.30	G 230
572343	5.70	234.30	
572393	5.70	239.30	G 240
572493	5.70	249.30	G 250
572593	5.70	259.30	G 260
572693	5.70	269.30	G 270
572793	5.70	279.30	G 280
572893	5.70	289.30	G 290

Part Number	C/S	I.D.	Cross Ref. #
572993	5.70	299.30	G 300
573193	5.70	319.30	
573393	5.70	339.30	
573493	5.70	349.30	
573593	5.70	359.30	
573793	5.70	379.30	
573993	5.70	399.30	
60012	6.00	12.00	
60018	6.00	18.00	
60020	6.00	20.00	
60023	6.00	23.00	
60024	6.00	24.00	
60025	6.00	25.00	
60026	6.00	26.00	
60032	6.00	32.00	
60034	6.00	34.00	
60035	6.00	35.00	
60036	6.00	36.00	
60037	6.00	37.00	
60038	6.00	38.00	
60040	6.00	40.00	
60041	6.00	41.00	
60042	6.00	42.00	
60044	6.00	44.00	
60045	6.00	45.00	
60046	6.00	46.00	
60048	6.00	48.00	
60050	6.00	50.00	
60052	6.00	52.00	
60056	6.00	56.00	
60058	6.00	58.00	
60059	6.00	59.00	
60060	6.00	60.00	
60062	6.00	62.00	
60064	6.00	64.00	
60065	6.00	65.00	
60067	6.00	67.00	
60069	6.00	69.00	
60070	6.00	70.00	
60072	6.00	72.00	
60073	6.00	73.00	
60074	6.00	74.00	
60075	6.00	75.00	
60076	6.00	76.00	
60079	6.00	79.00	
60080	6.00	80.00	
60085	6.00	85.00	
60086	6.00	86.00	
60088	6.00	88.00	
60090	6.00	90.00	
60092	6.00	92.00	

# O-Ring Sizing Charts

## Metric O-Ring Sizes

Part Number	C/S	I.D.	Cross Ref. #
60095	6.00	95.00	
60098	6.00	98.00	
60100	6.00	100.00	
60103	6.00	103.00	
60105	6.00	105.00	
60110	6.00	110.00	
60112	6.00	112.00	
60114	6.00	114.00	
60115	6.00	115.00	
60118	6.00	118.00	
60120	6.00	120.00	
60122	6.00	122.00	
60124	6.00	124.00	
60125	6.00	125.00	
60128	6.00	128.00	
60130	6.00	130.00	
60134	6.00	134.00	
60135	6.00	135.00	
60138	6.00	138.00	
60140	6.00	140.00	
60142	6.00	142.00	
60145	6.00	145.00	
60146	6.00	146.00	
60148	6.00	148.00	
60150	6.00	150.00	
60160	6.00	160.00	
60165	6.00	165.00	
60166	6.00	166.00	
60169	6.00	169.00	
60170	6.00	170.00	
60172	6.00	172.00	
60175	6.00	175.00	
60180	6.00	180.00	
60185	6.00	185.00	
60190	6.00	190.00	
60195	6.00	195.00	
60200	6.00	200.00	
60208	6.00	208.00	
60210	6.00	210.00	
60215	6.00	215.00	
60220	6.00	220.00	
602225	6.00	222.50	V 225
60230	6.00	230.00	
60242	6.00	242.00	
60250	6.00	250.00	
60262	6.00	262.00	
60266	6.00	266.00	
60270	6.00	270.00	
60272	6.00	272.00	V 275
60290	6.00	290.00	
60295	6.00	295.00	

Part Number	C/S	I.D.	Cross Ref. #
60300	6.00	300.00	
60320	6.00	320.00	
603215	6.00	321.50	V 325
60330	6.00	330.00	
60355	6.00	355.00	
60365	6.00	365.00	
60370	6.00	370.00	
60376	6.00	376.00	
603765	6.00	376.50	V 380
60380	6.00	380.00	
60385	6.00	385.00	
60392	6.00	392.00	
60394	6.00	394.00	
604255	6.00	425.50	V 430
60429	6.00	429.00	
60445	6.00	445.00	
60478	6.00	478.00	
60480	6.00	480.00	
60500	6.00	500.00	
60504	6.00	504.00	
60525	6.00	525.00	
60575	6.00	575.00	
-425	6.99	113.67	-425
-426	6.99	116.84	-426
-427	6.99	120.02	-427
-428	6.99	123.19	-428
-429	6.99	126.37	-429
-430	6.99	129.54	-430
-431	6.99	132.72	-431
-432	6.99	135.89	-432
-433	6.99	139.07	-433
-434	6.99	142.24	-434
-435	6.99	145.42	-435
-436	6.99	148.59	-436
-437	6.99	151.77	-437
-438	6.99	158.12	-438
-439	6.99	164.47	-439
-440	6.99	170.82	-440
-441	6.99	177.17	-441
-442	6.99	183.52	-442
-443	6.99	189.87	-443
-444	6.99	196.22	-444
-445	6.99	202.57	-445
-446	6.99	215.27	-446
-447	6.99	227.97	-447
-448	6.99	240.67	-448
-449	6.99	253.37	-449
-450	6.99	266.07	-450
-451	6.99	278.77	-451
-452	6.99	291.47	-452
-453	6.99	304.17	-453

Part Number	C/S	I.D.	Cross Ref. #
-454	6.99	316.87	-454
-455	6.99	329.57	-455
-456	6.99	342.27	-456
-457	6.99	354.97	-457
-458	6.99	367.67	-458
-459	6.99	380.37	-459
-460	6.99	393.07	-460
-461	6.99	405.26	-461
-462	6.99	417.96	-462
-463	6.99	430.66	-463
-464	6.99	443.36	-464
-465	6.99	456.06	-465
-466	6.99	468.76	-466
-467	6.99	481.46	-467
-468	6.99	494.16	-468
-469	6.99	506.86	-469
-470	6.99	532.26	-470
-471	6.99	557.66	-471
-472	6.99	582.68	-472
-473	6.99	608.08	-473
-474	6.99	633.48	-474
-475	6.99	658.88	-475
70011	7.00	11.00	
70015	7.00	15.00	
70023	7.00	23.00	
70034	7.00	34.00	
70035	7.00	35.00	
70040	7.00	40.00	
70058	7.00	58.00	
70059	7.00	59.00	
70060	7.00	60.00	
70068	7.00	68.00	
70079	7.00	79.00	
70083	7.00	83.00	
70094	7.00	94.00	
70096	7.00	96.00	
70106	7.00	106.00	
70107	7.00	107.00	
70110	7.00	110.00	
70111	7.00	111.00	
701147	7.00	114.70	
70115	7.00	115.00	
70120	7.00	120.00	
70128	7.00	128.00	
70150	7.00	150.00	
701595	7.00	159.50	
70160	7.00	160.00	
701667	7.00	166.70	
701746	7.00	174.60	
70181	7.00	181.00	
701873	7.00	187.30	



Part Number	C/S	I.D.	Cross Ref. #
70200	7.00	200.00	
702089	7.00	208.90	
70212	7.00	212.00	
70215	7.00	215.00	
70217	7.00	217.00	
70220	7.00	220.00	
70230	7.00	230.00	
70234	7.00	234.00	
702343	7.00	234.30	
70235	7.00	235.00	
70236	7.00	236.00	
70240	7.00	240.00	
70247	7.00	247.00	
70250	7.00	250.00	
702597	7.00	259.70	
70266	7.00	266.00	
702851	7.00	285.10	
702978	7.00	297.80	
70300	7.00	300.00	
70310	7.00	310.00	
70325	7.00	325.00	
70329	7.00	329.00	
70338	7.00	338.00	
70348	7.00	348.00	
70388	7.00	388.00	
70400	7.00	400.00	
70416	7.00	416.00	
70430	7.00	430.00	
70431	7.00	431.00	
70437	7.00	437.00	
70448	7.00	448.00	
70515	7.00	515.00	
70540	7.00	540.00	
70558	7.00	558.00	
70625	7.00	625.00	
80016	8.00	16.00	
80025	8.00	25.00	
80033	8.00	33.00	
80050	8.00	50.00	
80054	8.00	54.00	
80055	8.00	55.00	
80060	8.00	60.00	
80065	8.00	65.00	
80067	8.00	67.00	
80070	8.00	70.00	
80075	8.00	75.00	
80090	8.00	90.00	
80092	8.00	92.00	
80110	8.00	110.00	
80112	8.00	112.00	
80125	8.00	125.00	

Part Number	C/S	I.D.	Cross Ref. #
80140	8.00	140.00	
80144	8.00	144.00	
80145	8.00	145.00	
80160	8.00	160.00	
80175	8.00	175.00	
80184	8.00	184.00	
80185	8.00	185.00	
80188	8.00	188.00	
80200	8.00	200.00	
80205	8.00	205.00	
80210	8.00	210.00	
80230	8.00	230.00	
80235	8.00	235.00	
80245	8.00	245.00	
80278	8.00	278.00	
80290	8.00	290.00	
80300	8.00	300.00	
80308	8.00	308.00	
80320	8.00	320.00	
80326	8.00	326.00	
80330	8.00	330.00	
80425	8.00	425.00	
80440	8.00	440.00	
80470	8.00	470.00	
80475	8.00	475.00	
80480	8.00	480.00	
80490	8.00	490.00	
80500	8.00	500.00	
80565	8.00	565.00	
841441	8.40	144.10	
841495	8.40	149.50	P 150A
841541	8.40	154.10	
841545	8.40	154.50	P 155
841591	8.40	159.10	
841595	8.40	159.50	P 160
841641	8.40	164.10	
841645	8.40	164.50	P 165
841695	8.40	169.50	P 170
841741	8.40	174.10	
841745	8.40	174.50	P 175
841795	8.40	179.50	P 180
841845	8.40	184.50	P 185
841895	8.40	189.50	P 190
841941	8.40	194.10	
841945	8.40	194.50	P 195
841991	8.40	199.10	
841995	8.40	199.50	P 200
842041	8.40	204.10	
842045	8.40	204.50	P 205
842085	8.40	208.50	P 209
842091	8.40	209.10	

Part Number	C/S	I.D.	Cross Ref. #
842095	8.40	209.50	P 210
842145	8.40	214.50	P 215
842191	8.40	219.10	
842195	8.40	219.50	P 220
842245	8.40	224.50	P 225
842295	8.40	229.50	P 230
842345	8.40	234.50	P 235
842391	8.40	239.10	
842395	8.40	239.50	P 240
842445	8.40	244.50	P 245
842495	8.40	249.50	P 250
842545	8.40	254.50	P 255
842595	8.40	259.50	P 260
842645	8.40	264.50	P 265
842695	8.40	269.50	P 270
842745	8.40	274.50	P 275
84319	8.40	319.00	
843345	8.40	334.50	
844191	8.40	419.10	
10X475	10.00	475.00	V 480
10X5245	10.00	524.50	V 530
10X579	10.00	579.00	V 585
10X6335	10.00	633.50	V 640
10X683	10.00	683.00	V 690
10X7325	10.00	732.50	V 740
10X782	10.00	782.00	V 790
10X8365	10.00	836.50	V 845
10X1044	10.00	1044.00	V 1055

## Extrusion (Nibbling)



**Description:** The seal develops ragged edges, generally on the low-pressure side, which appear tattered.

**Contributing Factors:** Excessive clearances, excessive pressure, low modulus/hardness elastomer, excessive gland fill, irregular clearance gaps, sharp gland edges, improper sizing.

**Suggested Solutions:** Decrease clearances, higher-modulus/hardness elastomer, proper gland design, use of polymer backup rings.

## Over-Compression



**Description:** The seal exhibits parallel flat surfaces (corresponding to the contact areas) and may develop circumferential splits within the flattened surfaces.

**Contributing Factors:** Improper design-failure to account for thermal or chemical volume changes, or excessive compression.

**Suggested solutions:** Gland design should take into account material responses to chemical and thermal environments.

## Spiral Failure



**Description:** The seal exhibits cuts or marks which spiral around its circumference.

**Contributing Factors:** Difficult or tight installation (static), slow reciprocating speed, low-modulus/hardness elastomer, irregular O-ring surface finish, (including excessive parting line), excessive gland width, irregular or rough gland surface finish, inadequate lubrication.

**Suggested Solutions:** Correct installation procedures, higher-modulus elastomers, internally lubed elastomers, proper gland design, gland surface finish of 8-16 microinch RMS, possible use of polymer backup rings.

### Compression Set



**Description:** The seal exhibits a flat-sided cross-section, the flat side corresponds to the mating seal surfaces.

**Contributing Factors:** Excessive compression, excessive temperature, incompletely cured elastomer, elastomer with high compression set, excessive volume swell in chemical.

**Suggested Solutions:** Low compression set elastomer, proper gland design for the specific elastomer, confirm material compatibility.

### Outgassing/Extraction

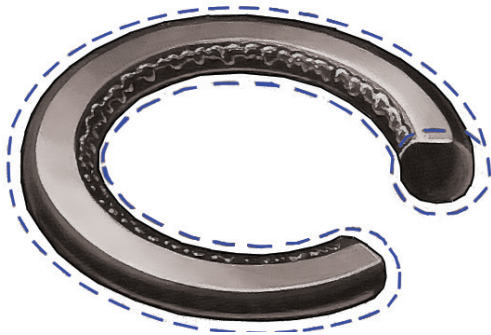

**Description:** The seal may exhibit a decrease in cross-sectional size. The failure is often very difficult to detect from examination of the seal.

**Contributing Factors:** Improper or improperly cured elastomer, high vacuum levels, low hardness/plasticized elastomer.

**Suggested Solutions:** Avoid plasticized elastomers, ensure all seals are properly post-cured to minimize outgassing.

### Installation Damage



**Description:** The seal or parts of the seal may exhibit small cuts, nicks, or gashes.

**Contributing Factors:** Sharp edges on the glands or components, improper sizing of elastomer, low-modulus/hardness elastomer, elastomer surface contamination.

**Suggested Solutions:** Remove all sharp edges. Proper gland design, proper elastomer sizing, higher-modulus/hardness elastomer.

## Chemical Degradation



**Description:** The seal may exhibit many signs of degradation including blisters, cracking, voids or discoloration. In some cases, the degradation is observable only by measurement of physical properties.

**Contributing Factors:** Incompatibility with the chemical and/or thermal environment.

**Suggested Solutions:** Selection of a more chemically resistant elastomer.

## Thermal Degradation



**Description:** The seal may exhibit radial cracks located on the highest temperature surfaces. In addition, certain elastomers may exhibit signs of softening—a shiny surface as a result of excessive temperatures.

**Contributing Factors:** Elastomer thermal properties, excessive temperature excursions or cycling.

**Suggested Solutions:** Selection of an elastomer with improved thermal stability, evaluation of the possibility of cooling sealing surfaces.

## Explosive Decompression



**Description:** The seal exhibits blisters, pits or pocks on its surface. Absorption of gas at high pressure and the subsequent rapid decrease in pressure. The absorbed gas blisters and ruptures the elastomer surface as the pressure is rapidly removed.

**Contributing Factors:** Rapid pressure changes, low-modulus hardness elastomer.

**Suggested Solutions:** Higher-modulus/hardness elastomer, slower decompression (release of pressure).

## Plasma Degradation



**Description:** The seal often exhibits discoloration, as well as powdered residue on the surface and possible erosion of the elastomer in the exposed area.

**Contributing Factors:** Chemical reactivity of the plasma, ion bombardment (sputtering), electron bombardment (heating), improper gland design, incompatible seal material.

**Suggested Solutions:** Plasma-compatible elastomer and compound, minimize exposed area, examine gland design.

## Contamination



**Description:** The seal exhibits foreign materials on the surface and/or within the O-ring.

**Contributing Factors:** Process environment deposition, reactions or degradation of the elastomer, non-semiconductor-grade elastomer.

**Suggested Solutions:** Specify contamination level including manufacturing and packaging of the seals.

## Abrasion



**Description:** The seal or parts of the seal exhibit a flat surface parallel to the direction or motion. Loose particles and scrapes may be found on the seal surface.

**Contributing Factors:** Rough sealing surfaces, excessive temperature, process environment containing abrasive particles, dynamic motion, poor elastomer surface finish.

**Suggested Solutions:** Use recommended gland surface finishes, consider internally lubed elastomers, eliminate abrasive components.

## Chloroprene (CR) (Neoprene - DowDuPont™)

-40°C to 121°C

-40°F to 250°F

- Has exceptional ozone, weather, and good chemical resistance
- Good mechanical properties are retained over a wide temperature range
- Exhibits good resistance to refrigerants (R12)
- Commonly used with ammonia
- Poor resistance to aromatic hydrocarbons, polar solvents, and toluene

## Ethylene Propylene (EPDM, EPR)

-54°C to 150°C

-65°F to 302°F

- Excellent resistance to ozone, hot water, steam, and aging
- Commonly used with brake fluids and refrigerants
- Poor resistance to petroleum fluids and mineral oils

## Fluorocarbon (FKM, FPM) (Viton™ - Chemours)

-26°C to 204°C

-15°F to 400°F

- Excellent resistance to higher temperatures, petroleum oils, and gasoline
- Wide range of chemical resistance
- Very good ozone, weather, and aging resistance
- Poor compatibility with H<sub>2</sub>S over 2%, amines, acetone, hot water, and steam
- Poor low temperature characteristics
- Low temperature fluorocarbons are available with a minimum temperature of -40°C/-40°F

## Viton™ Extreme™ (FEPM,FKM) (Viton™ - Chemours)

-20°C to 204°C

-4°F to 400°F

- Viton™ Extreme™ is a fluorocarbon compound that exhibits significantly improved performance over regular Viton™
- Provides the excellent thermal resistance along with significantly advanced chemical resistance

## Fluorosilicone (FVMQ, FMQ)

-56°C to 204°C

-69°F to 400°F

- Wide temperature range
- Excellent resistance to hydrocarbon fuels, petroleum oils, and silicone oils
- Relatively low tear strength, abrasion resistance, and tensile strength
- Generally not suited for dynamic applications

## Hydrogenated Nitrile (HNBR)

-40°C to 160°C

-40°F to 320°F

- A nitrile based compound with improved chemical resistance
- Wider temperature range than standard nitrile
- High strength material that resists extrusion, abrasion, and wear
- Water and steam resistance to +149°C/+300°F
- H<sub>2</sub>S resistance up to 10%
- Commonly used with petroleum oils and CO<sub>2</sub>
- Not to be used with chlorinated hydrocarbons, polar solvents, or strong acids

## Nitrile (NBR)

-40°C to 120°C

-40°F to 248°F

- Presently the most widely used elastomer in the seal industry
- Provides an exceptional balance of good mechanical properties, wear properties and chemical resistance
- Resistant to most mineral oils and greases
- Do not use with glycol-based brake fluids and strong acids
- Low temperature nitrile compound available with a minimum temperature of -54°C/65°F

## Polyetheretherketone (PEEK) (Ketrion® - Mitsubishi Chemical Advanced Materials)

-70°C to 260°C /

-94°F to 500°F

- High strength
- Able to retain its mechanical properties at high temperatures
- Commonly used for anti-extrusion purposes
- Do not use with hydrochloric, nitric, or sulphuric acids

**Perfluoroelastomer (FFKM) (Kalrez® - DuPont)**

-15°C to 310°C

+5°F to 590°F

- Broadest chemical resistance of any elastomeric material
- Combines the sealing integrity of elastomers with chemical resistance approaching that of PTFE
- Not suitable with liquid sodium and potassium, fluorinated solvents, and refrigerants
- High temperature compounds available up to 325°C/617°F
- Kalrez® 4079 - A low compression set 75 durometer compound with excellent chemical resistance, good mechanical properties and outstanding hot air aging properties.
- Kalrez® Spectrum™ 6380 - An 80 durometer compound specifically developed for chemical processes involving hot, aggressive amines; in addition it has excellent overall chemical resistance.
- Kalrez® Spectrum™ 7090 - A 90 durometer compound that is specifically targeted for use in applications requiring high hardness/higher modulus properties. This compound has excellent mechanical properties including compression set resistance and explosive decompression resistance.

**Polyurethane (AU, EU)**

-54°C to 105°C

-65°F to 220°F

- Thermoplastic elastomer with higher tensile strength, toughness, and wear resistance
- Good combination of hardness and elasticity
- Good low temperature flexibility
- Used in high pressure hydraulic systems where parts are subject to wear

**Polytetrafluoroethylene (PTFE) (Teflon™ - Chemours)**

-268°C to 232°C /

-450°F to 450°F

- Virtually universal chemical resistance
- Very low coefficient of friction
- Fillers such as bronze, moly, glass, and carbon are commonly added to alter mechanical properties

**Silicone (VMQ)**

-65°C to 232°C

-85°F to 450°F

- Excellent resistance to oxidation and ozone degradation
- Wide temperature range
- Most commonly used in static applications due to its poor tensile strength and wear resistance
- Popular for food and medical applications

**FEPM (TFE/P) (Aflas® FEPM - Asahi Glass Co.)**

-9°C to 232°C

16°F to 450°F

- Good high temperature capability
- Resistant to strong acids and bases, amines, solvents and hot water
- Found in numerous applications in the oilfield industry
- Poor low temperature performance and low resilience

**Hytrel® (TPC- ET)(DuPont™)**

-54°C to 149°C

-65°F to 300°F

- A thermoplastic elastomer able to handle high temperatures and hostile fluids
- Has excellent strength and toughness properties
- Demonstrates high resilience and flexibility which permits easier installation than PTFE materials
- Not suitable with water and phosphate fluids above +80°C/+176°F

\* Material information provided is based on multiple reference sources that are accepted by industry and is intended to serve as a general guideline. Testing material in the application environment is highly recommended.

**Hi-Tech Seals Branches:**

**Head Office** | 9211 - 41 Ave NW | Edmonton, AB | T6E 6R5 | Ph: 780.438.6055 | Fax: 780.434.5866

**Manufacturing Centre** | 9504 - 41 Ave NW | Edmonton, AB | T6E 6G9 | Ph: 780.439.4894 | Fax: 780.436.9502

**Calgary** | Bay #3, 5940 - 30 St. SE | Calgary, AB | T2C 1X8 | Ph: 403.720.2856 | Fax: 403.279.2662

**Winnipeg** | 445 Egesz St. | Winnipeg, MB | R2R 2V5 | Ph: 204.775.7881 | Fax: 204.775.7954

**Toronto** | 1180 Kerrisdale Blvd; Unit #8 | Newmarket, ON | L3Y 8Z9 | Ph: 905.953.9666 | Fax: 905.953.8739

**Montreal** | 2101 Rue Léonard-De Vinci | Ste-Julie, QC | J3E 1Z2 | Ph: 450.655.7325 | Fax: 450.655.7359

**Conroe** | 12064 FM 3083 | Conroe, TX | United States | 77301 | Ph: 936.206.3124 | Fax: 936.756.0538

**Broussard** | 226 Jared Drive | Broussard, LA | United States | 70518 | Ph: 337.347.8870 | Fax: 337.347.887

**Can-Tech Elastomers Inc. :**

Carrakeel Drive | Maydown Industrial State | Londonderry | Northern Ireland | BT47 6UQ | UK | Ph: +44.2871.861685