



Occupational Safety

Qualification Standard *Reference Guide*

JULY 2011

This page is intentionally blank.

Table of Contents

FIGURES	iii
TABLES	iv
ACRONYMS	v
PURPOSE	1
SCOPE	1
TECHNICAL COMPETENCIES	2
1. Occupational safety personnel must demonstrate a working level knowledge of philosophy, scope, application, and content of the following DOE and DOE-acknowledged programs directly influencing occupational safety:.....	2
2. Safety personnel must demonstrate a working level knowledge of DOE risk philosophy and how DOE manages risk.	10
3. Occupational safety personnel must demonstrate a working level knowledge of quality assurance program structure and content and of how quality programs and oversight support safety and health.	20
4. Occupational safety personnel must demonstrate a familiarity level knowledge of the organizational structure, mission, and primary documents of Federal, state, local and consensus organizations contributing to occupational safety.	24
5. Occupational safety personnel must demonstrate a working level knowledge of the occupational safety purpose, scope, program structure and requirements of 10 CFR 851, DOE O 440.1B, DOE technical standards, and Occupational Safety and Health Administration regulations.....	37
6. Occupational safety personnel must demonstrate a working level knowledge of hazard recognition theory and concepts of worker protection and control selection.	40
7. Occupational safety personnel must demonstrate a working level knowledge of hazard analysis techniques and of application of hazard control methods and mitigation activities.	45
8. Occupational safety personnel must demonstrate the ability to perform occupational safety trend analyses.....	52
9. Occupational safety personnel must demonstrate a working level knowledge of safety considerations associated with industrial operations.	55
10. Occupational safety personnel must demonstrate a working level knowledge of electricity and electrical hazards and controls to understand an electrical safety program and to coordinate it with an occupational safety program.	81
11. Occupational safety personnel must demonstrate a working level knowledge of safety in construction operations, including regulatory requirements.....	106
12. Occupational safety personnel must demonstrate a working level knowledge of accident/incident investigation, analysis, and reporting as it is practiced within DOE.....	127
13. Personnel must demonstrate a familiarity level knowledge of the occurrence reporting and processing system necessary to ensure that occurrences are properly reported and processed in accordance with DOE M 231.1-2, <i>Occurrence Reporting and Processing of Operations Information</i>	143
14. Occupational safety personnel must demonstrate a working level knowledge of the purpose, general content, development, and performance of worker occupational safety training.	145
15. Occupational safety personnel must demonstrate a working level knowledge of Motor Vehicle Safety.....	155

Table of Contents

16. Occupational safety personnel must demonstrate a working level knowledge of the requirements and methods to maintain communication with DOE-Headquarters, field elements (including contractors), other Federal agencies, and regulatory agencies.	162
17. Occupational safety personnel must demonstrate a working level knowledge of the development and management of both the technical and programmatic elements of an occupational safety program.	166
18. Occupational safety personnel must demonstrate a working level knowledge of assessment techniques applicable to evaluating occupational safety, reporting results, hazard mitigation and abatement, and following up on actions taken as the result of assessments.	184
19. Occupational safety personnel must demonstrate a working level knowledge of fire hazards and the principles and methods of fire prevention and protection.	191
20. Occupational safety personnel must demonstrate a working level knowledge of fall protection, including programs, training requirements, hazards and elimination or control.	202
21. Occupational safety personnel must demonstrate a working level knowledge of hoisting and rigging protection, including programs, training requirements, hazards and elimination or control of them.	230
22. Occupational safety personnel must demonstrate a familiarity level knowledge of ergonomic and human factors engineer hazards and their elimination or control.	248
23. Occupational safety personnel must demonstrate a working level knowledge of safety precautions and hazards associated with workplace chemicals and physical agents.	261
24. Personnel must demonstrate a familiarity level knowledge of basic material science.	297
25. Occupational safety personnel must demonstrate a familiarity level knowledge of the nuclear safety and radiological safety interfaces with occupational safety.	305
26. Occupational safety personnel must demonstrate working level knowledge of the application of basic and applied sciences to ISM.	309
27. Occupational safety personnel must demonstrate a familiarity level knowledge of safety in the research and development, manufacture, use, transportation, testing, demilitarization, storage and disposal of explosives in DOE M 440.1-1A, DOE Explosive Safety Manual. .	317
28. Occupational safety personnel must demonstrate a familiarity level knowledge of firearms safety and safeguards and security.	330
29. Occupational safety personnel must demonstrate a familiarity level knowledge of DOE contract management and administration sufficient to interface with contract officer and those contracted in areas of occupational safety.	338
30. Occupational safety personnel must demonstrate working level knowledge of industrial hygiene hazards and controls.	343
31. Occupational safety personnel must demonstrate a familiarity level knowledge of the use and function of worker protection safety testing and measurement equipment.	362
32. Occupational safety personnel must demonstrate a familiarity level knowledge of occupational medicine program and how it supports safety programs.	369
33. Occupational safety personnel must demonstrate a working level knowledge of conduct of operations and familiarity with configuration management.	390
34. Occupational safety personnel must demonstrate a familiarity level knowledge of mechanical systems operations and methods of failure that create hazards.	395
Bibliography and Suggested Reading	416

Table of Contents

FIGURES

Figure 1. HAZOP Process.....	51
Figure 2. A-weighted sound levels	68
Figure 3. Electrical junction box without a cover	94
Figure 4. Electrical wiring exposed in high traffic area.....	95
Figure 5. Electrical outlet without a cover.....	95
Figure 6. Electrical outlet with a broken cover.....	95
Figure 7. Performance measurement in the strategic management system	166
Figure 8. Boom angle indicator.....	240
Figure 9. Life-cycle model.....	260
Figure 10. Human factors engineering model.....	260
Figure 11. Typical static-producing situations, including charge separation in pipe	273
Figure 12. Bonding and grounding	274
Figure 13. Grounding above-ground storage tanks.....	275
Figure 14. Bonding during container filling	276
Figure 15. Storage container with spring loaded cover	278
Figure 16. A flammable liquid mixing and storage room.....	279
Figure 17. Gilian gilibrator	366
Figure 18. Bios DryCal™ DC-Lite.....	366
Figure 19. The PSM system.....	393
Figure 20. Gate valve	397
Figure 21. Globe valve.....	398
Figure 22. Ball valve.....	399
Figure 23. Swing check valve.....	400
Figure 24. Butterfly check valve.....	401
Figure 25. Variable reducing valve.....	401
Figure 26. Electric valve actuator	403
Figure 27. Pneumatic actuator	403
Figure 28. Valve conditions.....	406

Table of Contents

TABLES

Table 1. ISM and HPI integration	7
Table 2. Permissible noise exposures.....	69
Table 3. Minimum illumination intensities in foot candles	72
Table 4. A-C proof-test requirements	82
Table 5. D-C proof-test requirements	82
Table 6. Glove tests—water level	82
Table 7. Rubber insulating equipment voltage requirements.....	84
Table 8. Rubber insulating equipment test intervals.....	84
Table 9. Electrical severity factors.....	89
Table 10. Thresholds for defining shock hazards	90
Table 11. Electrical severity significance	90
Table 12. Effects of electric current in the human body	92
Table 13. Job/Safety Equipment Matrix—Use those applicable to the actual job being performed—50-V to 150-V line to ground to 250-V line to line AC or DC	99
Table 14. Job/Safety Equipment Matrix—Use those applicable to the actual job being performed—151-V line to ground to 600-V line to line AC or DC	100
Table 15. Job/Safety Equipment Matrix—Use those applicable to the actual job being performed—601-V to 15,000-V line to line AC.....	101
Table 16. Job/Safety Equipment Matrix – Use those applicable to the actual job being performed—electrolytic type battery work.....	102
Table 17. Job/Safety Equipment Matrix—Use those applicable to the actual job being performed—overhead line/switchyard work	103
Table 18. Accident investigation analytical techniques.....	130
Table 19. MORT coloring coding system.....	133
Table 20. Training methods	151
Table 21. Terms related to ergonomics.....	248
Table 22. Chemical incompatibilities.....	290
Table 23. Primary methods of entry.....	292
Table 24. Levels at which the provisions of the CBDPP apply	361
Table 25. PSM elements in actual practice	394
Table 26. Examples of incompatible materials	411

ACRONYMS	
ABIH	American Board of Industrial Hygiene
AC	alternating current
ACM	asbestos containing material
AEC	Atomic Energy Commission
AHJ	authority having jurisdiction
AHMP	Alliance of Hazardous Materials Professionals
AIB	accident investigation board
AJHA	automated job hazard analysis
ALARA	as low as reasonably achievable
ANSI	American National Standards Institute
APIH	Association of Professional Industrial Hygienists
ASC	Accredited Standards Committee
ASME	American Society of Mechanical Engineers
ASQ	American Society for Quality
ASSE	American Society of Safety Engineers
ASTM	American Society for Testing and Materials
ATSDR	Agency for Toxic Substances and Disease Registry
BCSP	Board of Certified Safety Professionals
BIO	basis for interim operations
CAIRS	computerized accident/incident reporting system
CBD	chronic beryllium disease
CBDPP	Chronic Beryllium Disease Prevention Program
CD	critical decision
CDC	Centers for Disease Control
CERCLA	Comprehensive Environmental Response, Compensation, and Liability Act
CFR	Code of Federal Regulations
cm	centimeter
CTA	central technical authority
CSTC	chemical safety topical committee
DART	days away, restricted time
D&D	deactivation and decommissioning
DC	direct current
DEAR	Department of Energy Acquisition Regulations
DMB	directives management board
DNA	deoxyribonucleic acid
DNFSB	Defense Nuclear Facilities Safety Board
DoD	U.S. Department of Defense
DOE	U.S. Department of Energy
DOE HQ OC	DOE Headquarters Operations Center
DOL	U.S. Department of Labor
DOT	U.S. Department of Transportation
DSA	documented safety analysis
DSC	department standards committee

ACRONYMS

EAP	DOE Employee Assistance Program
EED	electro-explosive device
EFCOG	Energy Facility Contractors Group
ELF	extremely low frequency
EO	Executive Order
EPA	U.S. Environmental Protection Agency
EPI	emergency public information
ES	electrical severity
ES&H	environment, safety, and health
ESI	electrical severity index
ESS	engagement simulation system
ETBA	energy trace and barrier analysis
FAQS	functional area qualification standard
FECA	Federal Employees' Compensation Act
FEOSH	Federal Employee Occupational Safety and Health
FH	Fluor Hanford
FHA	fire hazard analysis
FMEA	failure mode and effect analysis
FPF	Federal protective forces
FRAM	Functions, Responsibilities and Authorities Manual
FTA	fault tree analysis
FTCP	Federal Technical Capability Program
GFCI	ground fault circuit interrupter
GOCO	government-owned contractor-operated
GSA	Government Services Administration
HASP	health and safety plans
HAZ	heat-affected zone
HAZOP	hazard and operability analysis
HAZWOPER	hazardous waste operations and emergency response
HE	high explosive
HEPA	high efficiency particulate air
HFE	human factors engineering
HPI	human performance improvement
HQ	DOE headquarters
HRO	high-reliability organizations
HRP	human reliability program
HSS	Office of Health, Safety, and Security
HVAC	heating, ventilation, and air conditioning
IEEE	Institute for Electrical and Electronics Engineers
IH	industrial hygiene
IHCC	DOE Industrial Hygiene Coordinating Committee
ILO	International Labour Organization
INPO	Institute for Nuclear Power Operations

ACRONYMS

IR	infrared
ISM	integrated safety management
ISMS	integrated safety management system
ISO	International Organization for Standardization
JSA	job safety analysis
JHA	job hazard analysis
KSA	knowledge, skill, and ability
LANL	Los Alamos National Laboratory
LPS	lightning protection system
M&O	management and operating
MOA	memorandum of agreement
MORT	management oversight and risk tree
MOU	memorandum of understanding
MPFL	maximum possible fire loss
MRL	minimal risk level
MRO	medical review officer
MSD	musculoskeletal disorder
MSDS	material safety data sheet
MW	microwave radiation
NASA	National Aeronautics and Space Administration
NASP	National Association of Safety Professionals
NDT	nondestructive test
NEC	National Electrical Code
NES	nuclear explosive safety
NFPA	National Fire Protection Association
NIOSH	National Institute for Occupational Safety and Health
NIST	National Institute of Standards and Technology
NMMP	nuclear maintenance management program
NNSA	National Nuclear Security Administration
NPH	natural phenomenon hazard
NRC	Nuclear Regulatory Commission
NRTL	Nationally Recognized Test Laboratory
NTS	noncompliance tracking system
OC	operations center
OJT	on-the-job training
OMB	Office of Management and Budget
ORPS	occurrence reporting processing system
OS	occupational safety
OSH	occupational safety and health
OSHA	Occupational Safety and Health Administration
OWCP	Office of Workers' Compensation Programs
PEL	permissible exposure limit
PERT	procurement evaluation and reengineering team

ACRONYMS

PES	potential explosion site
PET	project evaluation tree
PF	protective force
PFAS	personal fall arrest system
PHA	preliminary hazard analysis
PIC	person in charge
P&ID	pipng and instrument diagram
PPE	personal protective equipment
ppm	parts per million
PrHA	process hazard analysis
PRP	potentially responsible party
PSM	process safety management
PT	performance test
QA	quality assurance
QAP	quality assurance program
Q-D	quantity-distance
RCRA	Resource Conservation and Recovery Act
RF	radio frequency
ROPS	rollover protective structures
RULA	rapid upper limb assessment
RWP	radiological work permit
RWT	radiological worker training
SDO	standard development organization
SDZ	surface danger zone
SIG	special interest group
SOMD	site occupational medical director
SSC	structures, systems, and components
STEL	short-term exposure limit
TIM	training implementation matrix
TLV	threshold limit value
TPP	training program plan
TQP	Technical Qualification Program
TRC	total recordable cases
TNT	trinitrotoluene
TSP	technical standards program
TSPP	technical standards program procedure
UL	Underwriter's Laboratory
USQ	unreviewed safety question
UV	ultraviolet
VAR	volt-amperes-reactive
VCS	voluntary consensus standard
VOC	volatile organic compound
VPP	voluntary protection program

ACRONYMS

VWF	vibration-induced white finger
WP	white phosphorus
WSO	World Safety Organization

PURPOSE

The purpose of this reference guide is to provide a document that contains the information required for a Department of Energy (DOE)/National Nuclear Security Administration (NNSA) technical employee to successfully complete the Occupational Safety Functional Area Qualification Standard (FAQS). In some cases, information essential to meeting the qualification requirements is provided. Some competency statements require extensive knowledge or skill development. Reproducing all the required information for those statements in this document is not practical. In those instances, references are included to guide the candidate to additional resources. In some cases, the references listed herein are located in the archive section of the Directives home page.

SCOPE

This reference guide has been developed to address the competency statements in the July 2011 version of DOE-STD-1160-2011, *Occupational Safety Functional Area Qualification Standard*. Competency statements and supporting knowledge and/or skill statements from the qualification standard are shown in contrasting bold type, while the corresponding information associated with each statement is provided below it. The qualification standard for occupational safety contains 34 competency statements.

The competencies and supporting knowledge, skill, and ability (KSAs) statements are taken directly from the FAQS. Most corrections to spelling, punctuation, and grammar have been made without remark. Only significant corrections to errors in the technical content of the discussion text source material are identified. Editorial changes that do not affect the technical content (e.g., grammatical or spelling corrections, and changes to style) appear without remark. When they are needed for clarification, explanations are enclosed in brackets.

Every effort has been made to provide the most current information and references available as of July 2011. However, the candidate is advised to verify the applicability of the information provided. It should be noted that some of the directives referred to have been archived.

A comprehensive list of acronyms and abbreviations is found at the beginning of this document. It is recommended that the candidate review the list prior to proceeding with the competencies, as the acronyms and abbreviations may not be further defined within the text unless special emphasis is required.

Please direct your questions or comments related to this document to the NNSA Talent and Leadership Development Division.

TECHNICAL COMPETENCIES

1. **Occupational safety personnel must demonstrate a working level knowledge of philosophy, scope, application, and content of the following DOE and DOE-acknowledged programs directly influencing occupational safety:**
 - **DOE Policy 450.4A, *Safety Management System Policy***
 - **Human Performance Improvement (HPI)**
 - **High Reliability Organizations (see DOE-HDBK-1028-2009, Volume 1, *Concepts and Principles.*)**
- a. **Discuss relationships of Integrated Safety Management (ISM) to Federal regulatory requirements for safety.**

The following is taken from DOE G 440.1-8.

An ISM system ensures that safety is integrated into work performed at the site and incorporates a complete worker safety and health program that is compliant with 10 CFR 851, “Worker Safety and Health.” An ISM system is a dynamic system incorporating the concept of continuous improvement that will support worker safety as the work changes to meet new or revised missions of DOE.

- b. **Explain how ISM is translated from a contract requirement to contractor programs and procedures using a functional safety program as a model for discussion.**

The following is taken from DOE G 450.4-1B.

48 CFR 970.5204-2, “Laws, Regulations, and DOE Directives,” requires that environmental, safety, and health requirements be established and identified in the contract as list B. These requirements are either established by the DOE contracting officer or by a DOE-approved process that is described in the ISM system and used to develop a tailored set of standards, practices, and controls that are then incorporated into the contract. In either case, this list B must be maintained valid and current as part of the contract. The DOE procurement executive expects the head of the contracting activity to ensure that the contracting officer reviews and updates list B at least annually concurrent with the annual work scope and performance measure negotiations. Changes to DOE directives or Federal, state, and local laws and regulations may require changes to the ISM system description and implementation.

- c. **Describe and demonstrate understanding of the ISM approach from policy through implementation guides. Discuss objectives, core functions, and guiding principles approach to systematically integrate safety into management and work practices at all levels.**

The following is taken from DOE P 450.4A.

It is the Department’s policy that work be conducted safely and efficiently and in a manner that ensures protection of workers, the public, and the environment. To achieve this policy, effective safety requirements and goals are established; applicable national and international consensus standards are adopted; and where necessary to address unique conditions, additional standards are developed and effectively implemented. Implementing ISM requirements for Federal organizations are established through directives, and for contractor organizations through contract clauses.

Objective of Integrated Safety Management

The Department's ultimate safety goal is zero accidents, work-related injuries and illnesses, regulatory violations, and reportable environmental releases. The Department expects that for all activities and phases in the lifecycle of missions (design, construction, research and development, operations, and decommissioning and decontamination), appropriate mechanisms are in place to ensure that exposures to workers, the public, and the environment to radiological and nonradiological hazards are maintained below regulatory limits. Furthermore, DOE expects that deliberate efforts are taken to keep exposures to radiation as low as reasonably achievable (ALARA).

The Department will implement integrated safety management systems to systematically integrate safety into management and work practices at all levels in the planning and execution of work. All organizations will develop, maintain, and implement ISM systems for their operations and work practices, based on the ISM guiding principles and core functions. To improve effectiveness and efficiency, organizations are expected to tailor their safety management system to the hazards and risks associated with the work activities supporting the mission; including using established mechanisms to tailor requirements. Further, decisions impacting safety are made by technically qualified managers with knowledge of the.

Guiding Principles for Integrated Safety Management

The guiding principles are the fundamental policies that guide Department and contractor actions, from development of safety directives to performance of work.

- **Line Management Responsibility for Safety.** Line management is directly responsible for the protection of the public, the workers, and the environment. As a complement to line management, the Department's Office of Environment, Safety and Health provides safety policy, enforcement, and independent oversight functions.
- **Clear Roles and Responsibilities.** Clear and unambiguous lines of authority and responsibility for ensuring safety shall be established and maintained at all organizational levels within the Department and its contractors.
- **Competence Commensurate with Responsibilities.** Personnel shall possess the experience, knowledge, skills, and abilities that are necessary to discharge their responsibilities.
- **Balanced Priorities.** Resources shall be effectively allocated to address safety, programmatic, and operational considerations. Protecting the public, the workers, and the environment shall be a priority whenever activities are planned and performed.
- **Identification of Safety Standards and Requirements.** Before work is performed, the associated hazards shall be evaluated and an agreed-upon set of safety standards and requirements shall be established which, if properly implemented, will provide adequate assurance that the public, the workers, and the environment are protected from adverse consequences.
- **Hazard Controls Tailored to Work Being Performed.** Administrative and engineering controls to prevent and mitigate hazards shall be tailored to the work being performed and associated hazards.
- **Operations Authorization.** The conditions and requirements to be satisfied for operations to be initiated and conducted shall be clearly established and agreed-upon.

Core Functions for Integrated Safety Management

These five core safety management functions provide the necessary structure for any work activity that could potentially affect the public, the workers, and the environment. The functions are applied as a continuous cycle with the degree of rigor appropriate to address the type of work activity and the hazards involved.

- Define the Scope of Work. Missions are translated into work, expectations are set, tasks are identified and prioritized, and resources are allocated.
- Analyze the Hazards. Hazards associated with the work are identified, analyzed, and categorized.
- Develop and Implement Hazard Controls. Applicable standards and requirements are identified and agreed-upon, controls to prevent/mitigate hazards are identified, the safety envelope is established, and controls are implemented.
- Perform Work within Controls. Readiness is confirmed and work is performed safely.
- Provide Feedback and Continuous Improvement. Feedback information on the adequacy of controls is gathered, opportunities for improving the definition and planning of work are identified and implemented, line and independent oversight is conducted, and, if necessary, regulatory enforcement actions occur.

Integrated Safety Management—Mechanisms

- Safety Mechanisms define how the core safety management functions are performed. The mechanisms may vary from facility to facility and from activity to activity based on the hazards and the work being performed and may include
 - departmental expectations expressed through directives and contract clauses;
 - directives on identifying and analyzing hazards and performing safety analyses;
 - directives which establish processes to be used in setting safety standards; and
 - contractor policies, procedures and documents established to implement safety management and fulfill commitments made to the Department.

Responsibilities for Integrated Safety Management

Responsibilities must be clearly defined in documents appropriate to the activity. DOE responsibilities are defined in Department directives. Contractor responsibilities are detailed in contracts, regulations and contractor-specific procedures. For each management mechanism employed to satisfy a safety management principle or function, the associated approval authority needs to be established. The review and approval levels may vary commensurate with the type of work and the hazards involved.

Implementation of Integrated Safety Management

Implementation involves specific instances of work definition and planning, hazards identifications and analysis, definition and implementation of hazard controls, performance of work, developing and implementing operating procedures, and monitoring and assessing performance for improvement.

- d. **Outline the actions specified in the ISM policy and program that are needed to fully implement ISM, including ISM system description, periodic self assessments, and leadership and management actions needed to implement a quality ISM program.**

The following is taken from DOE G 450.4-1B, volume 2.

ISM System Description

48 CFR 970.5223-1, “Integration of Environment, Safety, and Health into Work Planning and Execution,” requires the contractor to manage and perform work in accordance with a documented safety management system. In most instances DOE contractors have documented safety management systems in place. The issue that remains is whether these documented systems fulfill all the conditions in the Federal regulations. Some contractors have found it advantageous to create a new document and incorporate it into their ISM systems. The function of this new document, which in some cases has been called an ISM system description, is to provide information concerning how the documentation is used to fulfill all the requirements. There may be a need to revise or provide documentation in addition to an ISM system description document if gaps are identified, but a description document appears to be needed in most cases.

Based on experience to date, the ISM system description document provides a road map to all other system documentation and also describes roles and responsibilities of the organization in using the documents.

Self-Assessments

An overarching assessment program must be developed within the framework of DOE regulation 10 CFR 830.120, “Quality Assurance” and DOE O 414.1C, *Quality Assurance*. This policy’s key element is a rigorous and credible contractor self-assessment program that is linked to the DOE safety management system.

Assessments are linked to, and derive substantial benefit from the following:

- Performance measures and performance indicators
- Line and independent evaluations
- Compliance with applicable requirements
- Data collection, analysis, and corrective actions
- Continuous feedback and performance improvement

The results and conclusions of the contractor’s assessments are available to DOE. There are many different types of, and purposes for, individual assessments conducted within DOE and contractor organizations. For example, some assess compliance with the law and contract requirements, while others seek areas for improvement beyond simple compliance. Some assessments evaluate a product or service while others evaluate the organization’s management system and its ability to yield the desired products and services.

Leadership and Management

The Deputy Secretary will convene a leadership group to annually review the initial set of complex-wide performance indicators to guide safety policy decisions and consider the need for changes to the set of indicators. Senior management can use the initial set of indicators over time as one input to determine if DOE safety management policy is having a positive effect on safety.

Individual sites and contractors can use the indicators to compare their ISM performance to DOE’s composite performance. In turn, DOE and its contractors can use the indicators as a starting point for safety assessment. For example, a contractor may observe significant differences between its worker radiation dose and DOE-wide performance.

This information can be used to develop an assessment of the contributing factors of exposure to identify improvements.

e. Discuss how human performance improvement meshes with ISM and how it can be applied within contractor safety programs.

The following is taken from DOE-HDBK-1028-2009.

DOE developed and began implementation of ISM in 1996. Since that time, the Department has gained significant experience with its implementation. This experience has shown that the basic framework and substance of the Department's ISM program remains valid. The experience also shows that substantial variances exist across the complex regarding familiarity with ISM, commitment to implementation, and implementation effectiveness. The experience further shows that more clarity of DOE's role in effective ISM implementation is needed. Contractors and DOE alike have reported that clearer expectations and additional guidance on annual ISM maintenance and continuous improvement processes are needed.

Since 1996, external organizations that are also performing high-hazard work, such as commercial nuclear organizations, Navy nuclear organizations, National Aeronautics and Space Administration, and others, have also gained significant experience and insight relevant to safety management. The ISM core function of "feedback and improvement" calls for DOE to learn from available feedback and make changes to improve. This concept applies to the ISM program itself. Lessons learned from internal and external operating experience are reflected in the ISM manual to update the ISM program. The ISM manual should be viewed as a natural evolution of the ISM program, using feedback for improvement of the ISM program itself. Two significant sources of external lessons learned have contributed to that manual: 1) the research and conclusions related to high-reliability organizations (HRO) and 2) the research and conclusions related to the human performance improvement (HPI) initiatives in the commercial nuclear industry, the U.S. Navy, and other organizations. HRO and HPI tenets are very complementary with ISM and serve to extend and clarify the program's principles and methods.

f. Explain the major tenets of HPI and describe how controlling personnel, environment, and management conditions reduces worker and operational risks.

The following is taken from DOE-HDBK-1028-2009.

The strategic approach to improving human performance within the DOE community embraces two primary challenges: 1) anticipate, prevent, catch, and recover from active errors at the jobsite, and 2) identify and eliminate latent organizational weaknesses that provoke human error and degrade controls against error and the consequences of error.

If opportunities to err are not methodically identified, preventable errors will not be eliminated. Even if opportunities to err are systematically identified and prevented, people may still err in unanticipated and creative ways. Consequently, additional means are necessary to protect against errors that are not prevented or anticipated. Reducing the error rate minimizes the frequency, but not the severity of events. Only controls can be effective at reducing the severity of the outcome of error. Defense-in-depth—controls, or

safeguards arranged in a layered fashion—provides assurance such that if one fails, remaining controls will function as needed to reduce the impact on the physical facility.

To improve human performance and facility performance, efforts should be made to 1) reduce the occurrence of errors at all levels of the organization and 2) enhance the integrity of controls, or safeguards discovered to be weak or missing. Reducing errors (Re) and managing controls (Mc) will lead to zero significant events (ØE). The formula for achieving this goal is $Re + Mc \rightarrow \text{ØE}$. Eliminating significant facility events will result in performance improvement within the organization.

g. Discuss the concepts of Human Performance Improvement (HPI) and Human Factors Engineering and explain how these integrate with ISM and work control to manage risk

A few examples of the integration of HPI with ISM are illustrated in table 1. The ISM core functions are listed in the left column going down the table. The HPI objectives appear as headers in the second and third columns on the table.

Table 1. ISM and HPI integration

Integrated Safety Management	Human Performance Improvement Strategic Approach	
ISM Core Functions	Reduce Human Error	Manage Controls
<p>Define the Scope of Work</p> <p>The task preview HPI tool supports this core function. It can be used to help eliminate error when reviewing the scope of work. During the task preview individuals who will perform the work</p> <ul style="list-style-type: none"> ▪ identify the critical steps ▪ consider the possible errors associated with each critical step and the likely consequences ▪ ponder the worst that could happen ▪ consider the appropriate human performance tools to use ▪ discuss other controls, contingencies, and relevant operating experience <p>This approach is intended to expand the work definition considerations and thus preclude omissions that could be overlooked during analyzing the hazards associated with the work to be accomplished.</p>	<p>When management expectations are set, the tasks are identified and prioritized, and resources are properly allocated, human performance can flourish. These organizational factors create a unique array of job-site conditions—a good work environment that sets people up for success. Human error increases when expectations are not set, tasks are not clearly identified, and resources are not available to carry out the job.</p>	<p>When work scope is defined and all the preparation to complete the task is at hand, the error precursors-conditions that provoke error are reduced. This includes things such as</p> <ul style="list-style-type: none"> ▪ unexpected equipment conditions ▪ workarounds ▪ departures from the routine ▪ unclear standards ▪ need to interpret requirements <p>Properly managing controls is dependent on the elimination of error precursors that challenge the integrity of controls and allow human error to become consequential.</p>

Integrated Safety Management	Human Performance Improvement Strategic Approach	
ISM Core Functions	Reduce Human Error	Manage Controls
<p>Analyze and Categorize the Hazards</p> <p>All types of hazards to workers, the public, and the environment.</p> <p>HPI tools that support this core function, including job-site review, pre-job briefing, and questioning attitude. These tools can be used to identify hazards and unsafe conditions before starting a job.</p>	<p>When hazards are properly analyzed during the ISM cycle, the results can be used to analyze the work procedure for latent weaknesses and initiate procedure changes to eliminate those weaknesses. Similarly, robust hazards analysis should consider error precursors in the work place such as</p> <ul style="list-style-type: none"> ▪ adverse environmental conditions ▪ unclear roles/responsibilities ▪ time pressures ▪ high workload ▪ confusing displays or controls 	<p>Reducing latent weaknesses in the procedures strengthens the engineering and administrative controls that are an important cornerstone of the overall defense system.</p> <p>Strong administrative and cultural controls can withstand human error. Controls are weakened when conditions are present that provoke error.</p> <p>Eliminating error precursors at the jobsite reduces the incidence of active errors.</p>
<p>Develop and Implement Hazard Controls</p> <p>HPI principle 2, “Error-likely situations are predictable, manageable, and preventable,” complements this ISM core function. Hazards are the markings for error-likely situations—a work situation in which there is greater opportunity for error when performing a specific action or task due to error traps. The recognition in HPI that error-likely situations can be managed and prevented supports the ISM core function that hazards are identifiable and controllable.</p> <p>HPI tools that support this core function are self-checking, peer check, procedure use and adherence.</p>	<p>The ISM core function, Implement Hazard Controls, improves conditions at the jobsite. HPI describes the job site as the location where behavior occurs during task performance and is characterized by environmental and individual factors. Environmental factors include conditions external to the individual and often beyond his or her direct control, such as procedure quality, component labeling, human-machine interface, heat, and humidity. Individual factors include conditions that are a function of the person assigned that task, such as knowledge, skills, experience, family problems, and color blindness.</p>	<p>Hazard controls initiated in the ISM framework are supplemental reinforcements to the engineered and administrative controls and barriers. Hazard controls not only help ensure worker and environmental safety, hazards controls also relieve workers from worry, stress, and anxiety when performing work in the face of known hazards. Such conditions provoke human error and mistakes. When hazard controls are in place, worker stress and anxiety drop, human performance improves, and human error decreases.</p>

Integrated Safety Management	Human Performance Improvement Strategic Approach	
ISM Core Functions	Reduce Human Error	Manage Controls
<p>Perform Work</p> <p>The consistent and effective use of HPI error-reduction tools when performing work reduces the probability that an active error may cause an accident or serious event. Error-reduction tools include among others:</p> <ul style="list-style-type: none"> ▪ Self-checking ▪ Questioning attitude ▪ Stop when unsure ▪ Effective communication ▪ Procedure use and adherence ▪ Peer-checking ▪ Second-person verifications ▪ Turnovers 	<p>This ISM core function supports the third HPI principle, “Individual behavior is influenced by organizational processes and values.” When operations authorization is performed correctly, it can be used as an independent verification of the work planning and control process for specific task. Management can use this verification process to ensure the organizational processes and values are in place to adequately support performance at the jobsite</p>	<p>The core value expectation that work can be performed safely is balanced by the first principle of HPI that states, “People are fallible, and even the best people make mistakes.” Because people err and make mistakes, it is all the more important that controls are implemented and properly maintained.</p>

Source: DOE-HDBK-1028-2009

h. Discuss the relationships between high reliability organizations concepts and ISM principles to include discussion about organizational structure, leadership, corporate programs, and training and qualifications.

As part of the ISM revitalization effort, the Department wants to address known opportunities for improvement based on DOE experience and integrate the lessons learned from HRO organizations and HPI implementation into the Department’s existing ISM infrastructure. The Department wants to integrate the ISM core functions, ISM principles, HRO principles, HPI principles and methods, lessons learned, and internal and external best safety practices into a proactive safety culture where

- facility operations are recognized for their excellence and high-reliability
- everyone accepts responsibility for their own safety and the safety of others
- organization systems and processes provide mechanisms to identify systematic weaknesses and ensure adequate controls
- continuous learning and improvement are expected and consistently achieved

Work planning and control processes derived from ISM are key opportunities for enhancement by application of HPI concepts and tools. In fact, an almost natural integration can occur when the HPI objectives—reducing error and strengthening controls—are used as integral to implementing the ISM core functions. Likewise the analytical work that goes into reducing human error and strengthening controls supports the ISM core functions.

Mandatory Performance Activities

i. Participate in a DOE or contractor sponsored assessment of ISM or HPI or similar corporate level safety management program under the guidance or mentoring of a qualifying official or other competent safety person.

This is a performance-based KSA. The Qualifying Official will evaluate its completion.

2. Safety personnel must demonstrate a working level knowledge of DOE risk philosophy and how DOE manages risk.

a. Describe the purpose of DOE M 411.1-1C, *Safety Management Functions, Responsibilities and Authorities Manual (FRAM)* and how it relates to risk management and risk oversight.

The following is taken from DOE M 411.1-1C.

DOE M 411.1-1C defines safety management functions, responsibilities, and authorities for DOE senior management with responsibilities for line, support, oversight, and enforcement actions. It provides detailed requirements to supplement DOE P 411.1, *Safety Management Functions, Responsibilities, and Authorities Policy*.

Delegation Order 00-002.00A delegates the following authority to the Under Secretary for Energy, Science and Environment: direct the head of a field organization to curtail or suspend operations of nuclear reactors/nuclear facilities, or related activities when continuing operations might result in an undue risk to the environment and/or to the safety and health of workers or the public. This delegation order does not apply to the NNSA.

The Under Secretary for Energy, Science, and Environment directs the heads of field organizations to curtail or suspend operations of nuclear reactors, nuclear facilities, or related activities when, in the opinion of the Under Secretary, continuing operations might result in an undue risk to the environment and/or to the safety and health of departmental or contractor employees or to the public.

b. Explain fundamental concepts of risk, risk management, and risk analysis.

The following is taken from DOE G 413.3-7A.

Programs and projects are of varied types and of differing complexity. The risks may span multiple levels of organizational management, crosscut multiple organizations, and/or crosscut different sites within the complex. For risk management to be effective, it should be an integral part of the organization's corporate enterprises-governance.

To implement the risk management principles and processes successfully, an organizational process perspective should be considered within which the risk management processes could operate. The processes and procedures, along with applicable tools to be used for performing risk management functions should be carefully considered, established, and well defined when implemented. The risk management processes should be carefully tailored to involve and meet the needs of the organization's internal planning, assessment, project controls, risk monitoring, reporting, and decision-making processes at the different levels of risk management.

A clearly defined integrated risk management framework should consider the structure and interactions of the management organization(s) and management levels. These should be charted or mapped out and institutionalized to help: align the organization(s) to accomplish the mission, in concert with the established requirements, policies, strategic plans, roles and responsibilities aligned via clearly defined and well-understood processes and procedures. This alignment should be done in order to meet the goals and objectives of the Department at all levels of the organization(s) supported by risk management-

based decision-making knowledge. Increase the interaction and communication between upper management and functional contributors, and to better understand all types of project risks, such as: political, economic, social, and technological, policy, program, project, financial, resource-based, health and safety, safeguards and security, and operational. Without this interaction, identification of risks and the communication and handling of risks cannot be adequately accomplished, or be well understood. Apply a consistent integrated systematic risk management process approach at all levels of risk management to support decision-making and encourage better understanding and application of the risk management process. For example, the same risk can exist in different organizational levels such as the contractor, the site DOE offices, and program headquarters offices. This risk may be shared by all of the organizations and may be managed by all utilizing different perspectives. This risk can also be within the same site and crosscut and affect other capital, cleanup, information technology, or operating projects, etc. Build a culture that fosters risk management related learning, innovation, due diligence, responsible leadership, management participation and involvement, lessons learned, continuous improvement, and successive knowledge transfer.

The risk management framework should be completely integrated into the procedures and processes of the organization. The risk management processes and procedures should be supported by management through self-assessments, lessons learned, and a continuous improvement environment.

Risk analysis should begin as early in the project life cycle as possible. The simplest analysis is a cost and benefit review, a type of qualitative review. The qualitative approach involves listing the presumed overall range of costs over the presumed range of costs for projected benefits. The result would be a high level overall assessment of the risks on the project.

After critical decision (CD)-1 approval, two forms of risk analysis may be performed: qualitative and quantitative. These analyses serve as the foundation for continuing dialog about future risk realizations and the need for the application of the contingency and management reserve.

c. Discuss the relationships of risk management to ISM, OSHA, and nuclear safety, including the relationships with DOE contractors.

ISM

The following is taken from DOE G 450.4-1B, volume 1.

Integration allows for effective and efficient management of risk to workers, the environment, and the public. It is DOE line management's responsibility to ensure that contractors

- develop and effectively implement an ISM system tailored to the risk of the work and the associated hazards
- develop and effectively integrate their safety management systems with the business and operational systems throughout their organizations

The integration process must also address all hazards and the possible risks these hazards may present to workers, the public, and the environment. Individuals responsible for engineering the processes should work with multidisciplinary teams who have direct

responsibility for analyzing hazards, identifying control measures derived from that analysis, and ensuring those measures are effective. Similarly, individuals responsible for operations should have direct responsibility for the safety of those operations and should be given the resources to implement the necessary controls.

OSHA

The following is taken from 29 CFR 1910.119.

The employer shall perform an initial process hazard analysis (PrHA)/hazard evaluation on processes covered by 29 CFR 1910, "Occupational Safety and Health Standards." The PrHA shall be appropriate to the complexity of the process and shall identify, evaluate, and control the hazards involved in the process. Employers shall determine and document the priority order for conducting process hazard analyses based on a rationale that includes such considerations as extent of the process hazards, number of potentially affected employees, age of the process, and operating history of the process.

The employer shall use one or more of the following methodologies that are appropriate to determine and evaluate the hazards of the process being analyzed.

- What-if
- Checklist
- What-if/checklist
- Hazard and operability study
- Failure mode and effects analysis (FMEA)
- Fault tree analysis (FTA); or an appropriate equivalent methodology

The PrHA shall address

- the hazards of the process
- the identification of any previous incident that had a likely potential for catastrophic consequences in the workplace
- engineering and administrative controls applicable to the hazards and their interrelationships such as appropriate application of detection methodologies to provide early warning of releases
- consequences of failure of engineering and administrative controls
- facility siting
- human factors
- a qualitative evaluation of a range of the possible safety and health effects of failure of controls on employees in the workplace

The PrHA shall be performed by a team with expertise in engineering and process operations, and the team shall include at least one employee who has experience and knowledge specific to the process being evaluated. Also, one member of the team must be knowledgeable in the specific PrHA methodology being used.

The employer shall establish a system to promptly address the team's findings and recommendations; ensure that the recommendations are resolved in a timely manner and that the resolution is documented; document what actions are to be taken; complete actions as soon as possible; develop a written schedule of when these actions are to be completed; communicate the actions to operating, maintenance, and other employees whose work assignments are in the process and who may be affected by the recommendations or actions.

At least every five years after the completion of the initial PrHA, the PrHA shall be updated and revalidated by a team meeting to ensure that the PrHA is consistent with the current process.

Nuclear Safety

The following is taken from Idaho National Laboratory, The Sapphire Program.

Note: The Sapphire Program is a risk analysis tool used at the Idaho National laboratory to analyze the risk in nuclear operations.

The systems analysis programs part of SAPHIRE implies it can analyze systems. According to SAPHIRE, a system is anything that can be represented by a fault tree logic model. A fault tree is a combination of logical AND and OR gates with inputs that we call basic events. Since a fault tree deals with undesirable events, the fault tree model describes ways in which a system can fail.

The system fault tree models can be a single entity unto itself or can be linked together with other fault trees. These fault tree models can have an almost unlimited number of logic gates and basic events (for a total of 64,000 each). The only limit to the number of minimal cut sets is the available hard drive space. With today's powerful desktop computers, complex logic models that produce millions of minimal cut sets can easily be handled by SAPHIRE. With the fastest computers available, these millions of cut sets are available in seconds. Rounding out the package is the availability of event tree models. Event trees allow for a structured modeling technique wherein a particular sequence of events can be represented. Event tree and fault tree modeling capabilities are built into SAPHIRE.

One of the early driving factors for the development of the SAPHIRE software was the limited availability of risk and reliability assessment tools. During the start of the 1980s, most risk analysis tools were hosted on super- or mainframe-computers where long analysis times resulted in significant costs. As personal computers became more powerful, it was realized that risk assessment software for this platform could greatly broaden the implementation of modern risk analysis techniques. Consequently, the PC-based SAPHIRE software was made available, giving anyone the ability to perform hands-on risk and reliability assessments.

This concept of providing a tool that allows hands-on analysis has evolved from simply developing PC-based software to producing a user friendly, context-driven software package that meets the needs of analysts world-wide. Available on the desktop, SAPHIRE gives anyone the ability to solve complex fault trees. In addition, SAPHIRE can address a variety of risk analysis methodologies including: fault tree to event tree linking, cut set matching, and event trees with boundary conditions.

In addition to the context-driven analysis approach with SAPHIRE, every bit of information contained in a SAPHIRE database can be extracted as a text file. These information text files can be used for multiple purposes such as archiving parts of the database, sharing of data, translation of information, and reporting.

Related to the systems analysis part of SAPHIRE, the reliability evaluations category is an integral facet of the SAPHIRE analysis capabilities. Fault trees can be constructed and analyzed to obtain different measures of system unreliability. These system measures are

- overall system failure probability;
- minimal cut sets size, number, and probability;
- event importance measures, including: Fussell-Vesely; Birnbaum; risk increase ratio and interval; risk reduction ratio and interval; group; and uncertainty importance.

Since many probabilistic reliability evaluations include an assessment of uncertainty, SAPHIRE is equipped with two powerful uncertainty propagation techniques: Monte Carlo and Latin Hypercube sampling. To take advantage of these sampling techniques, twelve uncertainty distributions are built in for easy pick-and-choose for the best distribution. To help manage the reliability analysis capabilities, a unique and comprehensive reporting tool is accessible. Built-in and user-defined reports are immediately available.

d. Explain how the DOE directives system and publications, including technical standards supports risk management and informed decision making.

The following is taken from DOE G 413.3-7A.

DOE G 413.3-7A, *Risk Management Guide*, describes an effective risk management processes. The continuous and iterative process includes updating project risk documents and the risk management plan and emphasizes implementation communication of the risks and actions taken. The guidelines may be tailored according to program guidance and the needs of projects. DOE programs may adopt other acceptable risk management approaches/methods as determined appropriate for the type of project and program maturity by the line management for the specific program. A program that has a methodology to adequately govern risk management may continue to use its own specific methodology.

DOE G 413.3-7A provides a suggested framework for identifying and managing key technical, schedule, and cost risks and how it integrates with the development and consistent use of government contingency and contractor management reserve. The DOE O 413.3B, *Program and Project Management for the Acquisition of Capital Assets*, states that risk management is an essential element of every project.

Risk management for this purpose is the handling of risks through specific methods and techniques within the bounds of project management. The definition of risk is a factor, element, constraint, or course of action that introduces an uncertainty of outcome that could impact project objectives. The risks to be handled should be comprised of threats and opportunities. Threats are risks with negative consequences, and opportunities are risks with positive benefits.

The suggested risk management process demonstrates a continuous and iterative process. This framework meets the requirements of the Order to be forward-looking, structured, and informative. The issue of the establishment of technical design margins to address the uncertainties or unknowns associated with the design is addressed in greater detail in the DOE guides; however, the risk and its uncertainty arising from designs are addressed by

DOE G 413.3-7A, as are the necessities of increased technical oversight requirements. Further, this risk management process has been developed to meet the overall monitoring and reporting requirements, and to allow one to continue to monitor those technical uncertainties.

DOE-HDBK-1101-2004, *DOE Handbook: Process Safety Management for Highly Hazardous Chemicals*, includes a comparison of the U.S. Environmental Protection Agency (EPA) Risk Management Program with the Occupational Safety and Health Administration (OSHA)'s Process Safety Management Program.

Appendix F of DOE-STD-1189-2008, *DOE Standard: Integration of Safety into the Design Process*, discusses the safety-in-design relationship with the risk management plan.

e. Discuss risk, DOE risk acceptance, who has responsibility for risk acceptance, and how are contractors informed of duties to control risk.

The following is taken from DOE G 413.3-7A.

Acceptance as a risk-handling strategy should be a deliberate decision and documented in the risk register. Acceptance of the risk does not mean that the risk is ignored. The risk should be included in the cost and schedule contingency impact analysis.

Examples of risks that might be accepted include the following:

- There will be fewer bidders on a design-build request for proposal than desired, but there will still be some competition.
- Funding for the next fiscal year is delayed due to continuing resolution.

The following is taken from Project Management Knowledge—Risk Acceptance.

There will be a number of times over the course of a project's life cycle that the project management team/team leader will realize a particular component of that project comes with a set or series of inherent risk. When this determination of risk is made, the project management team/team leader must make an assessment what the next course of action is to deal with these risks. In many cases, the project management team/team leader may make the determination to deviate from the previously determined project management plan in a way that best ameliorates and/or minimizes the risk. However, in certain cases, the project management team/team leader may make the determination that the risk is worth it due to the need and importance of the component in question, or due to a lack of a realistic alternative. This is known as risk acceptance.

f. Discuss appropriate or required measures for obtaining interpretations of, or variances/exemptions from, occupational safety requirements in 10 CFR 851, 10 CFR 830 and DOE orders, and explaining how these affect risk posture.

The following is taken from DOE O 440.1B.

The heads of field elements will review and forward to the DOE Chief Health, Safety, and Security Officer all exemptions, exceptions, and variances to mandatory worker protection requirements contained in DOE O 440.1B, *Worker Protection Program for DOE (Including the National Nuclear Security Administration) Federal Employees*. They will also conduct an annual review of the status of all exemptions to the requirements

contained in DOE O 440.1B to ensure that circumstances requiring the need for relief have not changed and that instituted controls are still implemented and appropriate.

The following is taken from DOE O 251.1C.

Requests for equivalencies and exemptions to DOE O 251.1C, *Departmental Directives Program*, must be in memorandum form and sent to the Office of Information Resources.

The memorandum must briefly justify the reasons for the equivalencies/exemptions.

The memorandum must reference the offices, or localities, and requirements for which the equivalency/exemption is sought.

The following is taken from DOE O 251.1C.

An exemption under the directives program is a release from one or more requirements in a DOE Order, notice, or manual that has been granted to a DOE element or a contractor.

If the Order, notice, or manual includes specific provisions for exemptions, equivalencies, or other forms of relief from the requirements in the document, then those provisions must be applied.

If the document does not include specific provisions for relief, the process applies to granting permanent or temporary relief from the applicable requirements in those documents.

This exemption process does not apply to requirements in regulations.

An approved exemption must be submitted to the Office of Information Resources.

Requirements for Federal Employees

When a DOE Order, notice, or manual is issued, the requirements in that document automatically apply to Federal elements as stated in the document. To acquire exemption from a requirement in a directive, a Federal element must use the relief process specifically included in the directive, or if there is no relief process in the directive, the exemption process in DOE O 251.1C. Federal elements are required to meet all applicable directives requirements unless relief is granted through one of these processes. An exemption granted to a contractor does not relieve Federal elements from the responsibility to obtain an exemption to related requirements for Federal elements.

Requirements for Contractors

Requirements in DOE Orders, notices, and manuals apply to contractors to the extent that they are incorporated in the contract. Contracting officers incorporate requirements from directives by referencing or copying sections of the contractor requirements document into the contracts.

The program office must identify requirements in the directives system that are applicable to a contract, develop a list of applicable requirements, and provide the list to the contracting officer. The contracting officer must include that list in the contract. That list constitutes the list of applicable directives referred to as list B.

In some cases, requirements included in list B will be tailored to the specific hazards and needs of activity through a DOE-approved process. Such processes include the standards/requirements identification process, the work-smart standards process, and the safety management system. If a requirement from a directive is excluded from list B using one of these processes, then it is not a contract requirement and does not require requesting an exemption.

If a requirement of a directive is included in list B of the contract and temporary or permanent relief from the requirement is sought, use this exemption process.

Exemption Approval Process

NNSA Facilities and Activities

Review and Approval

The approval authority must provide copies of the exemption request, appropriate supporting documentation, and the draft exemption, and with respect to each exemption request views from the following parties before granting an exemption:

- The cognizant secretarial officer
- The Office of Primary Interest
- Assistant Secretary for environment, safety, and health (ES&H) requirements
- The NNSA central technical authority (CTA) for requirements listed on the NNSA index of baseline nuclear safety requirements
- The approval authority may not grant the exemption until
 - the parties have indicated that there is no objection or
 - thirty (30) calendar days have passed without objection after providing the parties the draft exemption and associated documentation
- If one of the parties objects, the approval authority must proceed as follows or deny the exemption:
 - Work with the objecting party to resolve any issues and withdraw the objection.
 - For unresolved objections from NNSA personnel, raise the issue to the NNSA Administrator or designee for resolution.
 - For unresolved objections from parties outside of NNSA, raise the matter through the NNSA Administrator or designee to the Deputy Secretary for resolution.

Approval Authority

Unless otherwise stated in the directive, approval is as follows:

- Heads of departmental NNSA elements approve exemptions to requirements in DOE Orders, notices, and manuals for activities and facilities under their direction.
- For ES&H requirements in Orders, notices, and manuals for hazard category 1 nuclear facilities, the Under Secretary for Nuclear Security approves exemptions. This authority may be delegated to other heads of departmental NNSA elements.

Exemption Requests

Requests for exemptions must include the following information:

- Site or facility for which an exemption is being requested
- Reference to the requirements for which exemption is sought

- Identification and justification of the acceptance of any additional risks that will be incurred if the exemption is granted
- Benefits to be realized by providing the exemption
- Whether the exemption being requested is temporary or permanent and for temporary exemptions, indication of when compliance will be achieved
- Identification of other pertinent data or information used as a basis for obtaining an exemption

Requests for exemptions to ES&H requirements must also address the following:

- A description of any special circumstances that warrant the granting of an exemption, including whether
 - application of the requirement in the particular circumstances would conflict with another requirement;
 - application of the requirement in the particular circumstances would not achieve, or is not necessary to achieve its underlying purpose;
 - application of the requirement in the particular circumstances would not be justified by any safety and health benefit;
 - the exemption would result in a health and safety benefit that compensates for any detriment that would result from granting the exemption; or
 - other material circumstances that exist were not considered when the requirement was adopted for which it is in the public interest to grant an exemption
- Steps to be taken to provide adequate protection of health, safety, and the environment, and a statement that adequate protection will be provided
- A description of any alternative or mitigating actions that have or will be taken to ensure adequate safety and health and protection of the public, the workers, and the environment for the period the exemption will be effective

Approval Criteria

For all exemption decisions, the basis for approving the exemption must be documented in the approval and the approving authority may grant an exemption only if the exemption

- is not prohibited by law;
- would not present an undue risk to public health and safety, the environment, facility workers, or security; and
- is warranted under the circumstance.

g. Understand Worker's Compensation.

The following is taken from Federal Employee's Worker Compensation Legal Library.

The Federal Employees' Compensation Act (FECA) provides for the payment of workers' compensation benefits to civilian officers and employees of all branches of the government of the United States. The regulations describe the rules for filing, processing, and paying claims for benefits under the FECA. Proceedings under the FECA are non-adversarial in nature.

The FECA provides for payment of several types of benefits, including compensation for wage loss, schedule awards, medical and related benefits, and vocational rehabilitation

services for conditions resulting from injuries sustained in performance of duty while in service to the United States.

The FECA also provides for payment of monetary compensation to specified survivors of an employee whose death resulted from a work-related injury and for payment of certain burial expenses.

h. Describe DOE requirements for and values of applying hazard analysis techniques during the design phase of a facility, operation, process, or piece of equipment.

The following is taken from DOE G 440.1-1A.

Incorporating worker protection features and requirements in the design and construction of facilities and equipment is the most cost-effective way to control hazards. Design reviews should be initiated at the earliest design phase and continue throughout the design process to ensure that potential hazards are identified, evaluated, and to the extent feasible, eliminated or controlled through design changes. Where hazards cannot be controlled through design changes, procedural or administrative controls or the use of personal protective equipment (PPE) should be considered. Preliminary hazard analyses (PHAs) provide a broad hazard screening tool that includes a review of the types of operations that will be performed in the proposed facility and identifies the hazards associated with these types of operations and facilities. The results of the PHAs are used to determine the need for additional, more detailed analysis, serve as a precursor where further analysis is deemed necessary, and serve as a baseline hazard analysis where further analysis is not indicated. The PHA is most applicable in the conceptual design stage, but it is also useful for existing facilities and equipment that have not had an adequate baseline hazard analysis. A facility hazard analysis is a detailed study to identify and analyze potential hazards associated with each aspect of the facility and related equipment and operations. The analysis should include a systematic review of each facility component and task and should consider

- facility design characteristics such as electrical installations, platform heights, egress concerns;
- proposed equipment, including types of equipment, location of equipment relative to the other operations and workers, required equipment interfaces, etc.;
- proposed operations, including related hazardous substances and potential exposures, potential energy sources, locations of operations and required interfaces, resulting material and personnel traffic patterns, etc.; and
- facility and equipment maintenance requirements, including confined space concerns, electrical hazards, inadvertent equipment startup or operation hazards, etc.

For hazards identified either in the facility design or during the development of procedures, controls are incorporated in the appropriate facility design or procedure. Hazards that are identified in the design phase of new facilities and facility modifications or during the development or modification of procedures should be eliminated or controlled through design or procedure changes. The controls implemented should be commensurate with the risk level identified in the risk assessment process.

Proposed design or procedure modifications intended to eliminate or control hazards should be reviewed by worker protection professionals to ensure that the change adequately addresses the hazard and does not introduce new workplace hazards. Alternative control measures should be evaluated to determine the reduction of risk provided by each measure and identify the most effective practical control for the hazard.

Hazards should also be addressed when selecting or purchasing equipment, products, and services. Provisions should be made for worker protection professionals and employee evaluation of pre-engineered or “off-the-shelf” equipment prior to selection and purchase.

This evaluation should focus on whether the equipment or procured material can perform its required task without endangering the health and safety of workers given existing facility and operational constraints. Evaluation methods can include

- review of equipment or material specifications
- observations of equipment or material demonstrations
- change analyses
- operational hazard analyses
- ergonomic/human factor analyses
- checks for suspect or counterfeit parts

Worker protection considerations to be taken into account when reviewing equipment specifications include

- health hazards
- operating noise
- temperature levels
- point-of-operation guards
- lockout provisions
- presence of hazardous material
- training requirements for safe operation
- ergonomic design, worker/machine interface
- maintenance requirements
- availability and practicality of “add-on” worker protection equipment
- existing facility and operational constraints

After installation of complex or potentially hazardous equipment, a pre-startup evaluation with affected workers, supervisors, and worker protection professionals should be conducted to verify safe conditions and identify any previously unforeseen hazards.

3. Occupational safety personnel must demonstrate a working level knowledge of quality assurance program structure and content and of how quality programs and oversight support safety and health.

a. Explain and gain evaluator experience in applying ISM and the concepts of DOE O 414.1D, *Quality Assurance*, during evaluation of work programs, practices and safety incidents.

This is a performance-based KSA. The Qualifying Official will evaluate its completion.

b. Identify key aspects of a quality program and explain why these are important to safety.

The following is taken from DOE O 414.1D.

Each DOE organization must develop and implement a quality assurance program (QAP) that does the following:

- Implements quality assurance (QA) criteria using a graded approach and describing how the criteria and graded approach are applied.
- Uses national or international consensus standards where practicable and consistent with contractual or regulatory requirements and identifies the standards used. Appropriate standards include the following:
 - American Society of Mechanical Engineers (ASME) NQA-1-2008, *Quality Assurance Requirements for Nuclear Facility Applications*
 - American National Standards Institute/International Organization for Standardization/American Society for Quality (ANSI/ISO/ASQ) Q 9001-2008, *Quality Management System: Requirements*
 - ANSI/ASQ Z 1.13, *Quality Guidelines for Research*,
- Applies additional standards, where practicable and consistent with contractual or regulatory requirements and as necessary to address unique/specific work activities.
- Integrates, where practicable and consistent with contract or regulatory requirements, quality management system requirements, including as applicable the following:
 - DOE P 450.4, *Safety Management System Policy*
 - NNSA Quality Management Policy, QC-1
 - DOE/RW-0333P DOE Office of Civilian Radioactive Waste Management, *Quality Assurance Requirements and Description*
 - DOE/CBFO-94-1012, DOE Carlsbad Field Office, *Quality Assurance Program Description*

c. Explain the major differences between the quality assurance requirements in 10 CFR 830 and DOE O 414.1D.

The following is taken from 10 CFR 830.

The major difference between the QA requirements in 10 CFR 830 and DOE O 414.1D is that 10 CFR 830 only applies to nuclear facilities.

d. Explain the need for the interface requirements between quality assurance and other management systems, such as integrated safety management, procurement, oversight, lessons learned, and construction management.

The following descriptions are taken from DOE G 414.1-1B unless stated otherwise.

Integrated Safety Management

The quality management system complements and is integrated with the safety management system, described in DOE P 450.4 and 48 CFR 970.5204-2. The quality management system provides processes and tools for ensuring that ISM system objectives are achieved. DOE P 450.4 expresses a fundamental expectation that all work will be performed safely. The DOE fundamental quality expectation is that all work meets established requirements. In this regard, the quality management system ensures compliance with the approved safety standards set, so that the expectation for safe work within controls is met. This also ensures that workers, the environment, and the public are reasonably protected from harm.

At the organizational or institutional level, the DOE quality and safety requirements share a management systems approach to achieving their objectives. As such, the required system documentation for each may be integrated into a single document to describe how the organization intends to implement the requirements. In some cases, the local DOE office and contractor may determine that it is expedient to maintain the ISM system description and the QAP. In these cases, as a minimum, the implementing mechanisms that are described in each should be integrated to the maximum extent practical, and the system description and QAP should cross-reference these procedures as applicable. For example, the processes and procedures for conducting management assessments should be referenced in both the QAP and the ISM system description.

Some shared attributes of quality and safety management systems may include

- expectations for implementation
- documentation of the management system
- clear roles and responsibilities
- balanced priorities
- feedback and improvement
- line management responsibility
- competence and qualifications
- standards and controls for work
- graded and tailored controls

Procurement Oversight

The procurement process should ensure that items and/or services provided by suppliers meet the requirements and expectations of the end user. The procurement process should be planned and controlled to ensure that

- the end user's requirements are accurately, completely, and clearly communicated to the supplier;
- supplier, designer, and end-user requirements are met during the production phase; and
- the proper product is delivered on time and maintained until use.

Procurement processes should prevent introduction of suspect/counterfeit items and provide a method to detect them before they are released for use.

The selection of procurement requirements should be commensurate with the importance of the end use of the purchased item or service. Management controls exist for DOE procurement and subcontracts through applicable DOE Orders.

The procurement process of DOE nuclear facility contractors must include a determination of the applicability of 10 CFR 830 to the supplier or subcontractor. If applicable, procurement documents and contracts for items and services provided to facilities covered by 10 CFR 830 should include a statement informing the supplier or subcontractor that it is subject to 10 CFR 830 and of the potential for enforcement actions under 10 CFR 820, "Procedural Rules of DOE Nuclear Activities."

Lessons Learned

The following is taken from DOE O 226.1B.

Formal programs must be established to communicate lessons learned during work activities, process reviews, and event analyses to potential users and applied to future work activities. Contractors must identify, apply, and exchange lessons learned with the rest of the DOE complex. Contractors must review and apply lessons learned identified by other DOE organizations and external sources to prevent similar occurrences.

Construction Management

The design process should translate design inputs into design output documents that are technically correct and compliant with the end user's requirements. Aspects critical to the performance, safety, or reliability of the designed items should be identified during the design phase. Design output documents should be prepared to support other processes such as dose and risk assessments, procurement, manufacturing, assembly, construction, testing, operation, inspection, maintenance, and decommissioning.

The completed design should be recorded in design output documents such as drawings, specifications, test/inspection plans, maintenance requirements, and reports. As-built drawings and shop drawings should be maintained after production or construction to show actual configuration. The administrative interface process should clearly indicate responsibilities for design output documents, including the requirements for document control, configuration management, and records management.

e. Define the terms: quality, quality assurance, quality assurance program, item, service, quality control, and process.

The following definitions are taken from 10 CFR 830.3 unless stated otherwise.

Quality

Quality is the condition achieved when an item, service, or process meets or exceeds the user's requirements and expectations.

Quality Assurance

Quality assurance consists of all those actions that provide confidence that quality is achieved.

Quality Assurance Program

A QAP consists of the overall program or management system established to assign responsibilities and authorities, define policies and requirements, and provide for the performance and assessment of work.

Item

Item is an all-inclusive term used in place of any of the following: appurtenance, assembly, component, equipment, material, module, part, product, structure, subassembly, subsystem, system, unit, or support systems.

Service

Service means the performance of work, such as design, manufacturing, construction, fabrication, assembly, decontamination, environmental restoration, waste management,

laboratory sample analyses, inspection, nondestructive examination/testing, environmental qualification, equipment qualification, repair, installation, or the like.

Quality Control

The following is taken from Builder: Quality Control vs. Quality Assurance.

Quality control refers to quality-related activities associated with the creation of project deliverables. Quality control is used to verify that deliverables are of acceptable quality and that they are complete and correct. Examples of quality control activities include deliverable peer reviews and the testing process.

Process

Process means a series of actions that achieves an end or result.

f. Demonstrate the ability to apply quality principles and criteria in DOE O 414.1D and 10 CFR 830, Subpart A.

This is a performance-based KSA. The Qualifying Official will evaluate its completion.

g. Explain how DOE Policy 226.1B, *Department of Energy Oversight Policy* and DOE O 226.1B, *Implementation of Department of Energy Oversight Policy* incorporate quality principles.

The following is taken from DOE O 226.1B.

Quality assurance oversight practices are to be integrated and enhanced as needed to meet the requirements of DOE O 226.1B for a comprehensive and rigorous assurance system.

DOE contractors must establish a comprehensive and integrated contractor assurance system in accordance with QA requirements. Contractors are required to ensure that work performance by subcontractors meets the applicable ES&H and QA requirements. The contractor must submit, for DOE review and approval, detailed contractor assurance system program descriptions to address quality.

Mandatory Performance Activities:

h. Demonstrate training on DOE O 414.1D or attend NQA-1 Lead Auditor or equivalent training.

This is a performance-based KSA. The Qualifying Official will evaluate its completion.

i. Explain and gain evaluator experience in applying ISM and the concepts of DOE O 414.1D, *Quality Assurance*, during evaluation of work programs, practices, and safety incidents.

This is a performance-based KSA. The Qualifying Official will evaluate its completion

4. Occupational safety personnel must demonstrate a familiarity level knowledge of the organizational structure, mission, and primary documents of Federal, state, local and consensus organizations contributing to occupational safety.

a. Discuss compatibility between, and describe the respective applicability of occupational safety requirements contained in DOE Orders and applicable local, state, or Federal regulations, and of related consensus standards.

The following is taken from 29 CFR 1960.1.

Federal regulations from 29 CFR 1960, “Basic Program Elements for Federal Employee Occupational Safety and Health Programs and Related Matters,” dictate the contents of DOE O 440.1B. State and local laws are to be met through the implementation of appropriate OSHA regulations for the given region. 29 CFR 1960 delineates the areas that must be covered and the requirements for Federal employees and contractors.

The following is taken from DOE G 440.1-1A.

DOE O 440.1B establishes the framework for an effective worker protection program that will reduce or prevent accidental losses, injuries, and illnesses by providing DOE Federal workers with a safe and healthful workplace. The worker protection program integrates occupational safety, and other functions addressed in standards required by the Order. The purpose of DOE O 440.1B is to establish a comprehensive worker protection program that reasonably ensures that DOE employees are afforded a level of safety and health on the job that is at least equal to that provided to its contractor employees and to private-sector employees under the Occupational Safety and Health Act of 1970. The Order establishes a baseline program that can be used as the foundation for the type of proactive worker protection program that the best employers in private industry have established for their workplaces.

The Federal Employee Occupational Safety and Health (FEOSH) Program is established in 29 CFR 1960. Requirements for FEOSH flow down into DOE O 440.1B and are reflected in DOE G 440.1-1A and in the DOE Federal Employee Occupational Safety and Health Handbook.

The following is taken from 29 CFR 1910.

The Williams-Steiger Occupational Safety and Health Act of 1970 provides that “without regard to chapter 5 of title 5, United States Code, or to the other subsections of this section, the Secretary shall, as soon as practicable during the period beginning with the effective date of this Act and ending 2 years after such date, by rule promulgate as an occupational safety or health standard any national consensus standard, and any established Federal standard, unless he determines that the promulgation of such a standard would not result in improved safety or health for specifically designated employees.” The legislative purpose of this provision is to establish, as rapidly as possible and without regard to the rule-making provisions of the Administrative Procedure Act, standards with which industries are generally familiar and on whose adoption interested and affected persons have already had an opportunity to express their views. Such standards are either 1) national consensus standards on whose adoption affected persons have reached substantial agreement, or 2) Federal standards already established by Federal statutes or regulations.

b. Explain the roles, purpose and applicability to DOE safety of the OSHA, NFPA, IEEE, NIOSH, CDC, INPO, ASTM, ASME, NRC and similar organizations.

Occupational Safety and Health Act

The following is taken from DOE O 440.1B.

The requirements section, part m, of DOE O 440.1B lists the applicable DOE and the OSHA worker protection requirements that are applicable to the hazards at the facilities. The Code of Federal Regulations (CFR) drives the DOE documents that are required, and the OSHA documents are applicable to all workers.

National Fire Protection Association (NFPA)

The following is taken from the NFPA web page.

The NFPA is an international nonprofit organization that was established in 1896. The company's mission is to reduce the worldwide burden of fire and other hazards on the quality of life by providing and advocating consensus codes and standards, research, training, and education.

With a membership that includes more than 75,000 individuals from nearly 100 nations NFPA is the world's leading advocate of fire prevention and an authoritative source on public safety.

Codes and Standards

The NFPA is responsible for 300 codes and standards that are designed to minimize the risk and effects of fire by establishing criteria for building, processing, design, service, and installation in the United States, as well as many other countries. Its more than 200 technical code- and standard- development committees are comprised of over 6,000 volunteer seats. Some of the codes used in DOE are

- NFPA 1, Fire Code
Provides requirements to establish a reasonable level of fire safety and property protection in new and existing buildings
- NFPA 70, National Electric Code
The world's most widely used and accepted code for electrical installations
- NFPA 101, Life Safety Code
Establishes minimum requirements for new and existing buildings to protect building occupants from fire, smoke, and toxic fumes

Institute of Electrical and Electronic Engineers (IEEE)

The following is taken from the IEEE-USA Operations Manual, Part A: Policies, Guidelines, and Procedures.

The purpose of the IEEE is to meet the following objectives:

- Promote the professional, social, economic, and ethical status of electrical, electronics, communications, and computer engineering, as well as computer science and allied branches of engineering and the related arts and sciences and technologies, and related technical professionals in the United States with a special emphasis on U.S. IEEE members.
- Provide technical advice and policy perspectives to U.S. policy-makers at all levels in the areas of electrotechnology and information technology to improve the quality of life and for the benefit of the public.
- Work with U.S. policy-makers and regulators to enhance the careers and improve the working conditions of U.S. engineers and other technical professionals.

- Develop products and services that support the lifelong professional development and career vitality needs of the IEEE's U.S. members and other technical professionals.
- Support communication with and among U.S. IEEE members, potential members, their employers and the public about IEEE-USA and the professional issues that affect our members and their professions.
- Enhance public awareness and understanding of electrical, electronics and computer engineering, and related technical fields.

National Institute of Occupational Safety and Health (NIOSH)

The following is taken from the NIOSH web page.

The mission of NIOSH is to generate new knowledge in the field of occupational safety and health and to transfer that knowledge into practice for the betterment of workers. To accomplish this mission, NIOSH conducts scientific research, develops guidance and authoritative recommendations, disseminates information, and responds to requests for workplace health hazard evaluations.

NIOSH provides national and world leadership to prevent work-related illness, injury, disability, and death by gathering information, conducting scientific research, and translating the knowledge gained into products and services, including scientific information products, training videos, and recommendations for improving safety and health in the workplace.

The following is taken from NIOSH Program Area: Radiation Dose Reconstruction.

The Energy Employees Occupational Illness Compensation Program Act established a compensation program for individuals who, over the past 50 years, have performed duties uniquely related to the nuclear weapons production and testing programs at DOE and its predecessor agencies. The Division of Compensation Analysis and Support will reconstruct radiation doses by evaluating all appropriate data relevant to which an individual worker or group of workers have been exposed, particularly when radiation monitoring data are unavailable, incomplete, or of poor quality. The data used for the dose reconstructions will be obtained through requests sent to DOE and data search and capture efforts.

Centers for Disease Control (CDC)

The following is taken from the CDC web page.

The CDC is one of the major operating components of the Department of Health and Human Services. CDC's mission is collaborating to create the expertise, information, and tools that people and communities need to protect their health through health promotion, prevention of disease, injury and disability, and preparedness for new health threats.

CDC seeks to accomplish its mission by working with partners throughout the nation and the world to

- monitor health
- detect and investigate health problems
- conduct research to enhance prevention
- develop and advocate sound public health policies

- implement prevention strategies
- promote healthy behaviors
- foster safe and healthful environments
- provide leadership and training

Those functions are the backbone of CDC's mission. Each of CDC's component organizations undertakes these activities in conducting its specific programs. The steps needed to accomplish this mission are also based on scientific excellence, requiring well-trained public health practitioners and leaders dedicated to high standards of quality and ethical practice.

Institute of Nuclear Power Operations (INPO)

The following is taken from the INPO web page.

The purpose of INPO is to

- promote the highest levels of safety and reliability
- to promote excellence in the operation of commercial nuclear power plants

We work to achieve our mission by

- establishing performance objectives, criteria and guidelines for the nuclear power industry;
- conducting regular detailed evaluations of nuclear power plants; and
- providing assistance to help nuclear power plants continually improve their performance.

INPO employees work to help the nuclear power industry achieve the highest levels of safety, reliability, and excellence through

- plant evaluations
- training and accreditation
- events analysis and information exchange
- assistance

These are the four cornerstones of INPO.

Plant Evaluations

INPO evaluation teams travel to nuclear electric generating facilities to observe operations, analyze processes, shadow personnel, and ask a lot of questions.

With an intense focus on safety and reliability, the evaluation teams assess the

- knowledge and performance of plant personnel
- condition of systems and equipment
- quality of programs and procedures
- effectiveness of plant management

Additionally, INPO conducts corporate evaluations that are also focused on safety and reliability.

Training and Accreditation

The National Academy for Nuclear Training provides training and support for nuclear power professionals.

Nuclear professionals from across the United States and throughout the world attend training at the INPO facility in Atlanta and take the various online courses offered by INPO.

In addition, INPOs evaluates individual plant and utility training programs to identify strengths and weaknesses and recommend improvements. Selected operator and technical training programs are accredited through the independent National Nuclear Accrediting Board.

Events Analysis and Information Exchange

INPO assists in reviewing any significant events at nuclear electric generating plants.

The INPO information exchange and publications communicate lessons learned and best practices throughout the nuclear power industry.

Assistance

At the request of individual nuclear electric generating facilities, INPO provides assistance with specific technical or management issues in areas related to plant operation and support.

American Society for Testing and Materials (ASTM)

The following is taken from the ASTM web page.

ASTM International is a globally recognized leader in the development and delivery of international voluntary consensus standards. Today, some 12,000 ASTM standards are used around the world to improve product quality, enhance safety, facilitate market access and trade, and build consumer confidence.

ASTM's leadership in international standards development is driven by the contributions of its members: more than 30,000 of the world's top technical experts and business professionals representing 135 countries. Working in an open and transparent process and using ASTM's advanced electronic infrastructure, ASTM members deliver the test methods, specifications, guides and practices that support industries and governments worldwide.

ASTM was formed in 1898 by chemists and engineers from the Pennsylvania Railroad. At the time of its establishment, the organization was known as the American Section of the International Association for Testing and Materials. Charles B. Dudley, Ph.D., a chemist with the Pennsylvania Railroad, was the driving force behind the formation of the society. In 2001, the society became known as ASTM International.

ASTM International standards are the tools of customer satisfaction and competitiveness for companies across a wide range of markets. Through 141 technical standards-writing committees, ASTM serves diverse industries ranging from metals to construction, petroleum to consumer products, and many more. When new industries look to advance the growth of cutting-edge technologies, such as nanotechnology and additive manufacturing, many of them come together under the ASTM International umbrella to achieve their standardization goals.

In the arena of global commerce, ASTM International standards are the passports to a successful trading strategy. High quality, market-relevant ASTM standards, developed in accordance with the guiding principles of the World Trade Organization, fuel trade by opening new markets and creating new trading partners for enterprises everywhere. From Fortune 500 leaders to emerging startups, ASTM standards help level the playing field so that businesses of all sizes can better compete in the global economy.

ASTM International standards are developed in accordance with the guiding principles of the World Trade Organization for the development of international standards: coherence, consensus, development dimension, effectiveness, impartiality, openness, relevance and transparency.

ASTM International welcomes and encourages participation from around the world in the development of its standards. ASTM's open consensus process, using advanced Internet-based standards development tools, ensures worldwide access for all interested individuals.

Beyond its leadership in the area of standards development, ASTM International offers technical training programs for industry and government, as well as proficiency testing, inter-laboratory crosscheck programs and newly initiated certification programs, which support manufacturers, users, researchers and laboratories worldwide.

American Society of Mechanical Engineers

The following is taken from the ASME web page.

ASME helps the global engineering community develop solutions to real world challenges. Founded in 1880 as the American Society of Mechanical Engineers, ASME is a not-for-profit professional organization that enables collaboration, knowledge sharing and skill development across all engineering disciplines, while promoting the vital role of the engineer in society. ASME codes and standards, publications, conferences, continuing education and professional development programs provide a foundation for advancing technical knowledge and a safer world.

Mission: To serve our diverse global communities by advancing, disseminating and applying engineering knowledge for improving the quality of life; and communicating the excitement of engineering.

Vision: ASME will be the essential resource for mechanical engineers and other technical professionals throughout the world for solutions that benefit humankind.

ASME's government relations programs, administered by its Washington center, offer members opportunities to provide Federal and state government officials with information and assistance on relevant public policy issues, such as energy and funding for science, technology, engineering, and mathematics education. Methods of outreach include briefings, seminars and conferences, and position statements.

ASME position statements communicate the viewpoints of groups within ASME that are engaged in a variety of issues presented before legislators and policymakers. ASME groups and committees lend a voice to the decision-making process on topics ranging from research and development funding and energy to education and national defense.

Nuclear Regulatory Commission (NRC)

The following information is taken from the NRC web page.

The NRC was created as an independent agency by Congress in 1974 to enable the nation to safely use radioactive materials for beneficial civilian purposes while ensuring that people and the environment are protected. The NRC regulates commercial nuclear power plants and other uses of nuclear materials, such as in nuclear medicine, through licensing, inspection and enforcement of its requirements.

c. Identify safety credentialing organizations and their scope, including those for safety professionals, industrial hygienists, professional engineers, health physicists, and those related to the TQP participant specific duty assignments.

All of the following descriptions are taken from the organization's web pages.

National Association of Safety Professionals (NASP)

The NASP offers professional and topical certifications for construction and general industry, including the vital general industry safety manager/trainer 40-hour course. All courses are available in the independent study format, delivered directly to the student by way of a computer download. Online testing is available at the end of every course.

Professional Certification Courses

There are 12 professional certifications, including the safety manager/trainer course, to choose from.

Topical Certification Courses

There are 29 topical certification courses to choose. All are independent studies, that allow participants to work at their own pace and many can be bundled together as a part of high-level professional certifications.

American Board of Industrial Hygiene (ABIH)

Since 1960, ABIH, a not-for-profit corporation, has been the world's largest, premier organization for certifying professionals in the practice of industrial hygiene. ABIH is responsible for ensuring high-quality certification application and examination processes, certification maintenance and ethics governance and enforcement.

Alliance of Hazardous Materials Professionals (AHMP)

The AHMP is a professional association with a membership of more than 4,000 of the nation's leading experts in environmental, health, safety, and security management. AHMP is the only national organization devoted to the professional advancement of the hazardous materials management field.

AHMP envisions a world where the natural environment is unburdened by pollution; workers are exposed only to healthy and safe conditions; and hazardous materials are used and transported safely and efficiently. As it has for more than two decades, AHMP works to advance the field of hazardous materials management to make its vision a reality. Its core purpose is to foster a community of professionals and to jointly advocate for the public recognition of the value of the certified hazardous material manager

credential and other environmental, health, safety, and security credentials the standards they represent and the professionals who uphold them.

Association of Professional Industrial Hygienists (APIH)

The APIH was established in 1994 to offer credentialing to industrial hygienists who meet the education and experience requirements found in Tennessee Code Annotated, Title 62, chapter 40. APIH adopted the Tennessee Code as its basis for credentialing because it was the first legal definition in the United States of an industrial hygienist in terms of education and experience. The APIH registration committee investigates and verifies, through electronic means or correspondence, both educational and experience accomplishments claimed by each applicant for registration. The committee determines the appropriate level of registration, registered industrial hygienist or registered professional industrial hygienist, and then authorizes the registration certificate to be issued.

Board of Certified Safety Professionals (BCSP)

The BCSP began in 1969 as a peer certification board. It is not a member organization and does not provide services usually offered by member organizations. Membership in any organization is not a requirement for certification.

Its sole purpose is to certify practitioners in the safety profession. Safety professionals identify hazards and evaluate them for the potential to cause injury or illness to people or harm of property and the environment. The safety professional recommends administrative and engineering controls that eliminate or minimize the risk and danger posed by hazards. They work with professionals in other disciplines in many different job settings. They work for companies, government agencies and private organizations or offer individual professional services. They may engage in design, planning, program management, training, audit and other aspects of practice. Additionally, they apply hazard recognition, evaluation and control knowledge and skills for equipment, systems, facilities and processes, or in operations, manufacturing, transportation, construction, insurance services and other enterprises.

World Safety Organization (WSO)

The purpose of the WSO is to internationalize all safety fields including occupational and ES&H, accident prevention movement, etc., and to disseminate throughout the world the practices, skills, arts, and technologies of the safety and accident prevention profession.

WSO provides facilities to pool technological and methodological knowledge in the health, safety, environmental, and accident prevention profession worldwide, in order to share this wealth of information. Membership in WSO is open to all individuals and entities involved in the multi-discipline field of safety and accident prevention, regardless of race, color, creed, ideology, religion, social status, sex, or political beliefs.

The WSO certification board, an independent WSO board, strives for a universal level of professionalism and competency among the WSO-certified members. The WSO-certified members are professionals in the multi-discipline of safety and accident prevention, recognized for their practical experience, education, and other learning programs, obtained through academic institutions and continuing education programs. WSO-certified members are involved in all areas of governments.

- d. Identify the DOE sponsored or DOE affiliated safety committees that provide technical expertise or professional opinions to DOE, including explosives, construction hoisting and rigging, beryllium, nanotechnology, and EFCOG working groups.**

DOE Fire Safety Committee

The purpose of the DOE Fire Safety Committee is to provide a forum to facilitate the interaction between the DOE, its program offices and contractor personnel with common interests regarding the identification and resolution of fire safety-related issues including the development of appropriate fire protection orders, guides, and technical standards.

DOE Behavioral Safety Committee

The purpose of the DOE Behavioral Safety Committee is to facilitate the interaction between DOE and DOE contractor personnel with common interests regarding behavioral safety programs. The DOE Behavioral Safety Committee also provides a forum to discuss use of behavioral techniques, to improve safety, to develop basic information or guidance for use of these techniques, and to explore other related issues for the DOE technical standards program office.

DOE Chemical Safety Topical Committee (CSTC)

The DOE CSTC is a volunteer organization co-sponsored by the DOE Office of Worker Safety and Health Policy and the ESH Workgroup of the Energy Facility Contractors Group (EFCOG) to provide a forum for DOE and DOE contractor personnel to identify chemical safety-related issues of concern to the DOE and pursue solutions to issues identified.

The CSTC promotes excellence in all aspects of chemical management through the exchange of lessons learned, best management practices, industry benchmarks, and technical advances and the sharing of ideas and tools that promote continuous improvement and excellence in chemical management.

DOE Metrology Accreditation Committee

The DOE Metrology Accreditation Committee website furnishes laboratories and interested visitors with the latest in DOE metrology accreditation developments throughout the DOE complex and provides a medium for exchange of information. Visitors are kept abreast of the latest developments in DOE laboratory accreditation and metrology standards.

Working in close partnership with the National Institute of Standards and Technology (NIST), the Committee's goals are to enrich DOE's accreditation capabilities through increased contact and reduced cost. The DOE Metrology Accreditation Committee internet site will be of value within and outside the DOE complex, nationally and internationally.

DOE Emergency Public Information (EPI) Subcommittee

The EPI subcommittee promotes and assists in developing emergency public information resources that serve the needs of all DOE/NNSA and contractor personnel. They share information, expertise, and resources for the continued improvement of emergency public information throughout the DOE/NNSA complex.

The purpose of the EPI subcommittee is to provide a forum for, and to facilitate the interaction between, DOE/NNSA and their contractor personnel with common interests in identifying and resolving emergency public information issues throughout the DOE/NNSA complex.

DOE Industrial Hygiene Coordinating Committee (IHCC)

The Secretary of Energy places a high priority on achieving excellence in DOE occupational health and safety programs. The Department is undertaking many critical initiatives in responding to this secretarial priority. In support of these critical initiatives, DOE established IHCC to efficiently and effectively communicate and coordinate intradepartmental IH program activities. The goal of this committee is to facilitate achieving the Department's priority of being an exemplary IH program in the IH community.

Industrial Hygiene/Occupational Safety (IH/OS) Special Interest Group

The IH/OS Special Interest Group (SIG) is a network of personnel from the DOE community involved in occupational safety and health issues. The IH/OS SIG provides the DOE community with tools for the development, enhancement, and/or implementation of programs and training designed to improve worker safety and health. The SIG's activities are directed by the IH/OS SIG Steering Committee, an elected body from the DOE safety and health community.

The IH/OS SIG Steering Committee also serves as the DOE Industrial Hygiene/Occupational Safety Topical Committee. The purpose of the Topical Committee is to provide a forum for, and facilitate interaction between, DOE and DOE contractor personnel to identify and resolve standards-related issues for the DOE technical standards program office.

e. Describe the difference between requests for information, advanced notice of proposed rulemaking, notice of proposed rulemaking, and a final rule as it relates to regulatory entries in the Federal Register.

Request for Information

The following is taken from 10 CFR 900.4.

An applicant, or prospective applicant, for a Federal authorization seeking information from a permitting entity must request information with a permitting entity, and notify the director of the request to the permitting entity. Any request for information filed under this section must specify in sufficient detail the information sought from the permitting entity and shall contain sufficient information for the permitting entity to provide the requested information.

Advanced Notice of Proposed Rulemaking

The following is taken from DOE/EH-413/9713.

An advanced notice of proposed rulemaking is an announcement appearing in the Federal Register that notifies the public of EPA's intent to publish a specific proposed rule.

Notice of Proposed Rulemaking

The following is taken from DOE/EH-413/9713.

A notice of proposed rulemaking is a document published in the Federal Register that sets forth proposed regulatory language, provides notice of issues to be commented on, and presents other supplementary and background information about the rulemaking.

Final Rule

The following is taken from the National Archives and Records Administration, Rules and Regulations.

Final rules and regulations: regulatory documents having general applicability and legal effect. A final rule document confirms that the interim rule is final, addresses comments received, and includes any further amendments. Additionally, this section includes documents that have no regulatory text and do not amend the CFRs, but either affect the agency's handling of its regulations or are of continuing interest to the public in dealing with an agency. In this category are general policy statements and interpretations of agency regulations. These documents have the CFR headings (title and part), but do not contain any codified language.

f. Discuss the purpose and applicability of DOE technical standards and where these can be located within the DOE directives program.

The following is taken from Department of Energy Technical Standards Program Procedures.

The DOE directives system includes a hierarchy of documents that describe how the Department performs work. There are four levels of documents in the hierarchy. The top level is policy. Policy documents describe the philosophy and fundamental values of the Department—the why we do it statements. The next level, requirements documents such as Orders and rules, identifies what must be done. These documents set expectations or specify criteria that must be met to ensure safe and reliable facility operations. They do not provide information on how to do work. Guides, the next level, provide general information and methodologies that DOE finds acceptable to meet the Department's requirements. In practice, the guides provide a link between the requirements and technical standards. The bottom level, technical standards, provides specific methods and techniques on how to implement the Department's requirements. Technical standards are the foundation upon which the DOE documents hierarchy is based. The activities of the technical standards program (TSP) are described in the technical standards program procedures (TSPPs) and the latest revisions of DOE O 252.1, *Technical Standards Program*, and DOE G-252.1-1, *Technical Standards Program Guide*.

Technical standards are available from a number of different sources. For DOE, the preferred source of technical standards is from the non-government standards community.

Note that throughout the TSPPs, two sets of terms are used interchangeably: 1) “non-government standards” and “voluntary consensus standards (VCSs)” are synonymous with “technical standards,” and 2) “non-government standards bodies” and “voluntary consensus standards bodies” are synonymous with standards development organizations (SDOs). Also note that a technical standard developed by and for DOE under the TSP is referred to as a DOE technical standard and includes DOE standards, DOE specifications, DOE handbooks, and DOE technical standards lists.

The non-government standards community includes international and national SDOs, such as the ISO, the International Electrotechnical Commission, the IEEE, the ASTM, the American Nuclear Society and the ASME. Other sources of technical standards include Federal standards, such as those issued by the General Service Administration and government standards, which are prepared and maintained by agencies of the Federal government.

Technical standards are used to transfer technology and standardize work processes to produce consistent acceptable results. They provide specific methods and techniques on how to implement DOE's requirements. The methods and techniques addressed in technical standards involve a range of activities, including the following: 1) common processes and production methods, and related management systems practices, and 2) the definition of terms; classification of components; delineation of procedures; specification of dimensions, materials, performance, designs, or operations; measurement of quality and quantity in describing materials, processes, products, systems, services, or practices; test methods and sampling procedures; or descriptions of fit and measurements of size or strength.

Through the proper selection and use of technical standards, DOE and its contractors can avoid costly duplication of effort and rework. Consequently, when searching for and selecting the right technical standards for a given application, DOE/contractor personnel are to first make use of existing VCSs or work with the appropriate SDO to have a VCS developed or revised to meet DOE's needs. If no existing VCS is adequate, an existing Federal or government standard that meets the need should be used. When neither an adequate VCS nor government standard exists nor can be developed on a schedule consistent with Department priorities, a DOE technical standard should be prepared. However, when a DOE technical standard is developed, DOE and its contractors should coordinate with an appropriate SDO on converting the new DOE technical standard to a VCS. This approach conforms with Federal requirements related to technical standards development and use established in public law and Federal policy described in Office of Management and Budget (OMB) Circular A-119.

Technical standards do not become requirements within DOE simply because the standards exist. Technical standards become mandatory documents when 1) they are cited as a requirement in a DOE policy or requirements document; 2) they are identified as mandatory in DOE-approved contractor documents, such as safety analysis reports, and sets of work-smart standards; or 3) they are identified as mandatory standards in contractual agreements between DOE and its contractors.

Because technical standards are recognized as the foundation of the documents hierarchy in DOE, two Department policy bodies were originally designated to overview the strategies and methods employed by the TSP. The Department Standards Committee (DSC) provided overall direction and vision on strategic standardization issues within DOE; the Directives Management Board (DMB) provided a similar function for the DOE directives system.

These functions were in transition in early 2000. The Field Management Council has since assumed the roles of both the DSC and DMB. The TSP serves as an integral element of DOE's management systems—part of the infrastructure supporting DOE's ISM system. The Department standards executive, designated in accordance with OMB

Circular A-119, directs implementation of the Department’s policy on the development and use of technical standards. In this role, the Department standards executive also represents DOE’s interests in Federal agency standardization activities coordinated by the Interagency Committee on Standards Policy.

5. **Occupational safety personnel must demonstrate a working level knowledge of the occupational safety purpose, scope, program structure and requirements of 10 CFR 851, DOE O 440.1B, DOE technical standards, and Occupational Safety and Health Administration regulations.**
 - a. **Discuss relationships between DOE orders and OSHA standards and have a working knowledge of the applicability of OSHA requirements to DOE and contractors, including subcontractors. Consider purpose, scope and applicability of:**
 - **29 CFR 1910, “Occupational Safety and Health Regulations”**
 - **29 CFR 1926, “Safety and Health Regulations for Construction”**
 - **10 CFR 851, “Worker Safety and Health Program”**

The following is taken from DOE G 440.1-8.

OSHA standards that address informing workers of hazards include, among others, 29 CFR 1910.1200, “Hazard Communication”; 29 CFR 1910.120, “Hazardous Waste Operations and Emergency Response”; 29 CFR 1910.146, “Permit-required Confined Spaces”; 29 CFR 1910.1030, “Blood-borne Pathogens”; and 29 CFR 1910, subpart Z, the specific toxic and hazardous substance regulations.

10 CFR 708, “DOE Contractor Employee Protection Program,” describes how contractor employee representatives are protected from acts of discharge, discipline, or other acts of retaliation that result from disclosure of information concerning danger to the public or worker health and safety; refusal to participate in dangerous activities, and other specified protected activities.

29 CFR 1910, Occupational Safety and Health Regulations

The following is taken from 29 CFR 1910.1.

Section 6(a) of the Williams-Steiger Occupational Safety and Health Act of 1970 provides that the Secretary shall promulgate as an occupational safety or health standard any national consensus standard, and any established Federal standard, unless he/she determines that the promulgation of such a standard would not result in improved safety or health for specifically designated employees. The legislative purpose of this provision is to establish standards with which industries are generally familiar, and on whose adoption interested and affected persons have already had an opportunity to express their views.

Such standards are either 1) national consensus standards on whose adoption affected persons have reached substantial agreement, or 2) Federal standards already established by Federal statutes or regulations.

29 CFR 1926, Safety and Health Regulations for Construction

The following is taken from 29 CFR 1926.1.

29 CFR 1926 sets forth the safety and health standards promulgated by the Secretary of Labor under section 107 of the Contract Work Hours and Safety Standards Act.

Subpart B of 9 CFR 1926 contains statements of general policy and interpretations of section 107 of the Contract Work Hours and Safety Standards Act having general applicability.

10 CFR 851

The worker safety and health requirements in this part govern the conduct of contractor activities at DOE sites.

10 CFR 851 establishes the

- requirements for a worker safety and health program that reduces or prevents occupational injuries, illnesses, and accidental losses by providing DOE contractors and their workers with safe and healthful workplaces at DOE sites; and
- procedures for investigating whether a violation of a requirement of this part has occurred, for determining the nature and extent of any such violation, and for imposing an appropriate remedy.

b. Discuss the OSHA General Duty Clause of Public Law 91-596, Section 5 (a)(1) and its applicability.

The following is taken from Public Law 91-596, Occupational Safety and Health Act of 1970.

Section 5(a)(1) of the OSH Act, often referred to as the general duty clause, requires employers to furnish to each employee employment and a place of employment that are free from recognized hazards that are causing or are likely to cause death or serious physical harm to his employees.

c. Discuss contract mechanisms and implementation processes that flow safety and health requirements from DOE to major contractors and their sub-tier contractors.

The following is taken from G 440.1-8.

10 CFR 851 applies to the conduct of contractor activities at DOE sites. These activities should include design, construction, operation, maintenance, decontamination and decommissioning, research and development, and environmental restoration activities performed by DOE contractors at covered workplaces. A covered workplace is a place at a DOE site where work is conducted by a contractor to further a DOE mission.

10 CFR 851 directs DOE contractors to perform work in a manner that protects the safety and health of workers, without regard to whether the workers are employed by a contractor engaged in a nuclear activity covered by agreements of indemnification under the Price-Anderson Act, or are engaged in a non-nuclear activity. DOE's authority to impose civil penalties, however, applies only to contractors, and their subcontractors and suppliers, covered by agreements of indemnification under the Price-Anderson Act, which, in turn, requires DOE to include an agreement of indemnification in every contract that has the potential to involve any activity with any risk of a nuclear incident.

Hence, DOE can impose civil penalties for violations of requirements of 10 CFR 851, but only against contractors covered by an agreement of indemnification and their subcontractors and suppliers. DOE will continue to use contractual penalties to foster compliance with 10 CFR 851 by contractors and their subcontractors that are not covered by an agreement of indemnification.

10 CFR 851.5, “Enforcement” establishes enforcement provisions that allow DOE to employ either civil penalties or contractual mechanisms such as reduction in fees when a contractor fails to comply with 10 CFR 851 provisions. DOE’s Office of Enforcement can start enforcement through civil penalties.

DOE’s Office of Enforcement will use DOE’s voluntary noncompliance tracking system (NTS) that allows contractors to elect to report noncompliance.

The Office of Enforcement currently uses the NTS for noncompliance with requirements for nuclear activities. 10 CFR 851 NTS reporting thresholds for reporting noncompliance of potentially greater worker safety and health significance into the NTS are available from a link on <http://www.eh.doe.gov/enforce/index.html>. The NTS is described in the guidance document, enforcement program plan, also available from a link at <http://www.eh.doe.gov/enforce/index.html>. Contractors are expected, however, to use their own self-tracking systems to track noncompliance below the reporting threshold.

d. Describe requirements and methods for achieving Federal employee safety under 29 CFR 1960, “Basic Program Elements for Federal Employee Occupational Safety and Health Programs and Related Matters,” and DOE O 440.1B, *Worker Protection Program for DOE (including the National Nuclear Security Administration) Federal Employees.*

29 CFR 1960

The following is taken from 29 CFR 1960.8.

The head of each agency shall furnish to each employee employment and a place of employment which are free from recognized hazards that are causing or are likely to cause death or serious physical harm.

The head of each agency shall comply with the OSHA standards applicable to the agency.

The head of each agency shall develop, implement, and evaluate an occupational safety and health program in accordance with the requirements of section 19 of the Act, Executive Order (EO) 12196, and the basic program elements prescribed in this part, or approved alternate program elements.

The head of each agency shall acquire, maintain, and require the use of approved PPE, approved safety equipment, and other devices necessary to protect employees.

To provide essential specialized expertise, agency heads shall authorize safety and health personnel to utilize such expertise from whatever source available, including but not limited to other agencies, professional groups, consultants, universities, labor organizations, and safety and health committees.

DOE O 440.1B

The following is taken from DOE G 440.1-8.

10 CFR 851 requires contractors to provide a place of employment that is free from recognized hazards that are causing or have the potential to cause death or serious physical harm to workers. This provision of 10 CFR 851 was carried over from DOE O 440.1A and closely parallels the OSHA general duty clause. Accordingly, in implementing this provision, contractors should consider criteria similar to those established by OSHA for the implementation of the general duty clause. Specifically, in determining whether a workplace condition presents a recognized hazard that is causing or has the potential to cause death or serious physical harm to workers, contractors should consider whether

- the condition presents a hazard to which workers are exposed
- the hazard is a recognized hazard
- the hazard is causing or is likely to cause death or serious physical harm
- feasible and useful methods exist to correct the hazard

The terms “feasible” and “serious physical harm” are subjective terms the meanings of which depend on the specific context in which the terms are used. The meanings of these terms in a situation should be determined by DOE line management starting with the head of the DOE field element and progressing to the Under Secretary depending on the impact of the meanings. DOE line managers should obtain input from safety and health professionals and other relevant subject matter experts in making their determinations.

Contractors must comply with the applicable requirements of 10 CFR 851 and their approved worker safety and health program for the contractor’s workplace. All work performed by contractors or subcontractors in a covered workplace must comply with 10 CFR 851.13, “Compliance.” Contractors must establish a written program that describes how the contractor will comply with the requirements that are applicable to the hazards associated with the contractor’s scope of work as well as the provisions of any compliance order issued by the Secretary. In addition, 10 CFR 851 states that nothing in the regulation must be construed as relieving a contractor from complying with any additional specific safety and health requirement that it determines to be necessary to protect the safety and health of workers.

6. Occupational safety personnel must demonstrate a working level knowledge of hazard recognition theory and concepts of worker protection and control selection.

a. Define hazard, consequences, risk, control, hazard analysis, incident likelihood, control.

The following definitions are taken from DOE-HDBK-1188-2006 unless stated otherwise.

Hazard

A source of danger with the potential to cause illness, injury, or death to a person or damage to a facility or to the environment.

Consequences

The following is taken from DOE G 413.3-7A.

Consequence is the outcome of an event. The outcome of an event may include cost and/or schedule impacts.

Risk

The quantitative or qualitative expression of possible loss that considers the probability that a hazard will cause harm and the consequences of that event.

Hazard Analysis

The determination of material, system, process, and plant characteristics that can produce undesirable consequences, followed by the assessment of hazardous situations associated with a process or activity. Largely qualitative techniques are used to pinpoint weaknesses in design or operation of the facility that could lead to accidents. The hazards analysis examines the complete spectrum of potential accidents that could expose members of the public, onsite workers, facility workers, and the environment to hazardous materials.

Control

When used with respect to nuclear reactors, apparatus and mechanisms that, when manipulated, directly affect the reactivity or power level of a reactor or the status of an engineered safety feature. When used with respect to any other nuclear facility, controls means apparatus and mechanisms, when manipulated could affect the chemical, physical, metallurgical, or nuclear process of the nuclear facility in such a manner as to affect the protection of health and safety.

Incident Likelihood

The following is taken from DOE G 413.3-7A.

Incident likelihood is the probability of an event occurring, expressed as a qualitative and/or quantitative metric.

b. Define the elements and application of a hazard abatement program.

The following is taken from DOE G 440.1-1A.

The relative level of risk should be assessed for each identified hazard to ensure that hazard abatement efforts and resources are focused first on addressing the most serious workplace hazards. Risk assessment is an essential element of effective risk management. The assignment of risk levels provides a relatively simple and consistent method of expressing the risk associated with worker exposures to identified hazards. Although important in prioritization and abatement planning, assigning a risk assessment code or level to a hazard should not be an impediment to quick abatement. If a hazard can be fixed immediately, assigning a risk category is not necessary, although organizations may prefer to assign one for trending purposes. The determination of the priority assigned to the abatement of a specific hazard should first be based on the risk of injury or illness the hazard presents to the worker; however, other factors may be considered, including

- regulatory compliance
- resources
- complexity of abatement
- organizational mission

In some cases, it may be appropriate to address lower-level hazards before higher-level hazards if quick abatement is possible.

Hazard abatement management requires a mechanism to track all planned abatement activities through to completion. Therefore, all hazards identified during worker protection evaluations should be recorded regardless of whether the evaluation was conducted by DOE, contractors, or external agencies such as OSHA. In addition, hazards identified by employees or line management should be recorded if they are not immediately abated. Hazard abatement information may be in any format as long as it

- meets its purpose of documenting identified hazards and associated corrective actions through final abatement
- allows for appropriate planning and budgeting decisions
- is retrievable

The following elements should be included in the documentation for each hazard:

- Location
- Date found
- Description of hazard
- Referenced DOE-prescribed worker protection standard
- Planned corrective action
- Estimated cost of abatement
- Interim protective measures
- Abatement period
- Scheduled abatement date
- Actual abatement date
- Risk level
- Record identification number

In addition, the information should also indicate if actual corrective action differs from planned corrective action.

c. Explain the concepts and application of integrated work planning and work control programs using the ISM model to include using integrated teams of knowledgeable individuals covering the range of safety functional areas (e.g., industrial hygiene, radcon, construction safety).

The following is taken from Activity Level Work Planning and Control Processes: Attributes, Best Practices, and Guidance for Effective Incorporation of Integrated Safety Management and Quality Assurance (The Document).

Department regulations and directives require that ISM and QA be integrated into work planning and control activities. The Department of Energy Acquisition Regulations (DEAR) require that work be performed safely in a manner that protects workers, the public, and the environment, and that the management of ES&H functions and activities be an integral and visible part of the work planning and execution process. The DEAR further requires that work be managed and performed in accordance with a documented safety management system that describes how the contractor will ensure that the ISM five core functions and seven guiding principles are implemented. The ISM core functions require that work be defined, the associated hazards identified and analyzed, and the

work performed within controls implemented to protect workers, the public, and the environment from the hazards.

The QA rule requires that contractors conducting activities, including providing items or services, that affect, or may affect, the nuclear safety of DOE nuclear facilities, conduct work in accordance with the QA criteria in 10 CFR 830.122, "Quality Assurance Criteria," and that the contractor responsible for a DOE nuclear facility conduct work in accordance with a QAP that integrates the QA criteria with the safety management system, or describe how the criteria apply to the safety management system. The QA criteria require that work be conducted consistent with hazard controls using approved instructions and procedures. DOE O 414.1C, requires application of the same QA criteria beyond nuclear facilities to cover all work performed at all DOE/NNSA facilities.

Additional quality management requirements for Nuclear Weapons Complex activities are provided in the DOE/NNSA Weapon Quality Policy, QC-1, Revision 10.

Taken collectively, the ISM DEAR clauses and QA criteria require a formal, deliberate process for identifying, scheduling, prioritizing, planning, analyzing, coordinating, performing, documenting, assessing, and improving work activities. The goal is safe, efficient, and reliable conduct of work in support of the NNSA mission. For a typical facility, work is multi-organizational and requires coordination, understanding, and support of those involved and/or impacted by work activities.

The document provides attributes and best practices/guidance for effectively incorporating ISM core functions and guiding principles, and QA criteria, into activity-level work planning and control processes. The attributes were drafted by DOE/NNSA headquarters, site office, and contractor personnel involved in work planning and control for the various types of NNSA non-office environment work activities. Thus the attributes are intended to be applicable to all types of work and the workers who perform the work. Information contained in this document also reflects input from the Defense Nuclear Facilities Safety Board (DNFSB) staff, INPO, EFCOG, and other sources related to activity level work planning and control.

The document focuses at the activity level because site-level ISM system descriptions, policies and procedures have been generally found to be adequate and to flow down to the facility level. Incorporation of the attributes into work planning and control processes will help to ensure that ISM and QA requirements are met. The attributes generally are derived from the QA criteria in 10 CFR 830.122 and the ISM core functions and guiding principles in the DEAR clauses that are included in management and operating (M&O) contracts. NNSA expects that processes used to plan and control activity-level work incorporate the attributes. Existing processes should be compared to the attributes, and corrective actions developed to eliminate identified gaps. The best practices and guidance listed under the attributes are not requirements and are not intended by NNSA for use as assessment criteria. Each site and contractor has unique work planning and control processes that have been developed to fit their specific situation to meet their specific needs. However, NNSA expects its contractors to review their work planning and control processes in light of the best practices and guidance and to make improvements to their processes where appropriate.

The attributes, supported by the best practices and guidance, provide the characteristics of an effective activity-level work planning and control process. Incorporating these characteristics into existing work processes should ensure appropriate incorporation of ISM and QA requirements from Department directives and regulations, contractor policies, and ISM systems into specific activity-level work tasks.

d. Discuss the need for hazard recognition and integrated control of hazards among collocated operational activities covering multiple competing safety functional areas.

The following is taken from DOE G 450.3-3.

Activity hazards analyses usually involve the analysis of multiple related tasks. These tasks may be related to work within a specific facility or location, or to work of a specific technical nature.

When multiple tasks are involved, activity hazards analyses can be used to analyze hazards arising at the interfaces of the tasks. They can also be used in planning to coordinate and schedule or sequence tasks to minimize hazards. For example, if an electrician must work in a facility in which other hazardous work is also being performed, then the electrician's work must be coordinated with ongoing facility work, and the electrician must be made aware of the hazardous activities going on in the facility.

Activity hazards analyses can help managers and supervisors coordinate tasks in time and space to get work done safely. They can also be used to confirm training needs and work authorization specifications for individual tasks.

Activity hazards analyses are most useful in deactivation and decommissioning (D&D) and environmental remediation operations, after hazards have been characterized, during work planning and work performance. They are performed as a routine part of the D&D and remediation processes. The description and uses of activity hazards analyses are well discussed in DOE/EH-0486, *Integrating Safety and Health During Deactivation with Lessons Learned from Purex*.

e. List typical DOE hazards and identify a work condition where each hazard is likely to be found.

This is a site-specific KSA. The local Qualifying Official will evaluate its completion.

f. Discuss application and effectiveness (pros and cons) of using computer based hazard identification and control tools or other automated logic processes.

The following is taken from DOE Office of Health, Safety, and Security, Automated Job Hazard Analysis.

Fluor Hanford (FH) uses job hazard analysis (JHA) as the primary vehicle to integrate the ISM core functions into work planning and execution. The automated job hazard analysis (AJHA) tool is used to achieve that objective. The FH ISM specifies requirements for the AJHA and delineates the approach for its integration with and implementation within the work management process. At the activity level, work management and ES&H

management processes are integrated to focus on the necessary elements of work planning and safety and environmental protection so that work can be conducted in a manner that ensures safety and environmental protection while optimizing productivity and efficiency. The AJHA is a fundamental element of work control for FH activities.

As a computer based job hazard analysis (JHA) tool, AJHA facilitates a team approach to job planning. This innovative approach has improved the quality and timeliness of work performance at Hanford. Employees are more involved and the exchange of information has allowed work planners to better describe the work to be completed. This has decreased down time because workers are better prepared when they arrive at the worksite.

The AJHA tool allows planners to perform upfront activities such as prescreening the work to determine level of risk and the degree of complexity. They can form a team to walk down the job and from a dropdown list put together the proper team of workers for the pre-job planning meeting.

The pre-job meeting is conducted with all the workers in attendance who are scheduled to perform the task. The meeting is generally facilitated by a work planner or a person in charge. If there is a large group in attendance, a dropdown screen and a projection unit such as an InFocus are utilized with the computer. The computer program leads the group through the task identification, an extensive list of potential hazards that are discussed and selected as appropriate and agreed upon. The next step is reviewing the controls selected by the program for the hazards identified. The program will define the controls that ensure compliance with regulations and identify them as mandatory. It also provides a listing of additional controls and space for special controls the team deems necessary. This ensures a level of safety for everyone working the task. The tool provides for a post job review and lessons learned.

Mandatory Performance Activities:

- g. Perform a walk down of an operation or facility D&D, waste management or construction project to identify that hazards are captured in the operations work planning and control documents.**

This is a performance-based KSA. The Qualifying Official will evaluate its completion.

- 7. Occupational safety personnel must demonstrate a working level knowledge of hazard analysis techniques and of application of hazard control methods and mitigation activities.**
 - a. Explain hazard analysis techniques, and derivation of controls to reduce worker and operational risk. Describe the hierarchy of hazard control methods.**

The following is taken from DOE G 440.1-1A.

Worker protection professionals should be assigned review and approval authority in all four phases of project design: conceptual design, preliminary design, final design, and inspection. Review during the conceptual design phase, the earliest phase of the project, is critical. Hazard analysis methodologies can be applied to facilities, processes, equipment, and operations throughout their life cycle. Methodologies include

- preliminary hazard analysis

- health hazard analyses
- facility hazard analysis
- process hazard analysis
- safety review

Preliminary hazard analyses (PHAs) provide a broad hazard screening tool that includes a review of the types of operations that will be performed in the proposed facility and identifies the hazards associated with these types of operations and facilities. The results of the PHA are used to determine the need for additional, more detailed analysis, serve as a precursor where further analysis is deemed necessary, and serve as a baseline hazard analysis where further analysis is not indicated. The PHA is most applicable in the conceptual design stage, but it is also useful for existing facilities and equipment that have not had an adequate baseline hazard analysis.

A facility hazard analysis is a detailed study to identify and analyze potential hazards associated with each aspect of the facility and related equipment and operations. The analysis should include a systematic review of each facility component and task and should consider

- facility design characteristics such as electrical installations, platform heights, egress concerns, etc.;
- proposed equipment including types of equipment, location of equipment relative to the other operations and workers, required equipment interfaces, etc.;
- proposed operations, including related hazardous substances and potential exposures, potential energy sources, locations of operations and required interfaces, resulting material and personnel traffic patterns, etc.; and
- facility and equipment maintenance requirements, including confined space concerns, electrical hazards, inadvertent equipment startup or operation hazards, etc.

The facility hazard analysis may identify the need for other more specialized hazard analyses by functional experts such as health hazard analyses and process hazard analyses.

The following techniques are available to assist in the performance of hazard analyses:

- **Safety Review.** A safety review is a technique to provide a detailed evaluation of facility operations or processes. It is used to identify hazards associated with conditions, practices, maintenance, and other pertinent aspects of the facility or process.
- **Change Analysis.** A change analysis is performed to ensure that design or proposed operational changes do not adversely affect the safety of the facility. The analysis identifies differences between the existing and the proposed design or operational change, identifies how the change will affect related features, and evaluates the effects of the differences and relationships on the overall safety of the facility. The change analysis is used during the design and construction phase of the facility to address proposed changes.
- **Energy Trace and Barrier Analysis (ETBA).** The ETBA identifies potential energy sources, traces those sources to a potential hazard, and determines if the proper barriers to the hazard are in place. The ETBA provides an effective tool to identify potential hazards for the PHA.

- Failure Modes and Effects Analysis. The FMEA is a critical review of the system (facility and operations), coupled with a systematic examination of all conceivable failures and an evaluation of the effects of these failures on the mission capability of the system. The FMEA can help avoid costly facility modifications and should be initiated early in the design phase. Once performed, the FMEA provides valuable information if updated throughout the design process.
- Fault Tree Analysis. The FTA is a logic tree used to evaluate a specific undesired event. The FTA is developed through deductive logic from an undesired event to all sub-events that should occur to cause the undesired event. The FTA can be applied at any point in the life of a facility. The FTA can be used to support the PHA during facility design.

DOE O 440.1B requires that hazard control methods be selected based on the following hierarchy:

- Substitution and/or elimination
- Engineering controls
- Work practices and administrative controls that limit worker exposures
- Personal protective equipment

b. Identify common types of engineering and administrative controls and discuss the applicability and relationships of each.

The following is taken from DOE G 440.1-1A.

Engineering Controls

Where substitution for a less hazardous operation or material is not an option and controls are necessary to reduce worker risk from exposure to workplace hazards, engineering controls should be implemented to the extent feasible. Principal engineering controls include

- enclosing the hazard
- locating hazardous operations or equipment in remote and/or unoccupied areas
- establishing physical barriers and guards
- using local and general exhaust ventilation

Administrative Controls

The effectiveness of work practice and administrative controls depends on the ability of line management to make employees aware of established work practices and procedures, to reinforce them, and to provide consistent and reasonable enforcement. Administrative controls include

- written operating procedures, safe work practices, and work permits;
- exposure time limitations;
- limits on the use of hazardous materials and monitoring of such operations;
- health and safety plans (HASPs);
- altered work schedules, such as working in the early morning or evening to reduce the potential for heat stress; and
- training employees in methods of reducing exposure.

c. Discuss importance of informing affected workers of hazards, mitigation and abatement activities, and application of controls.

The following is taken from DOE G 440.1-1A.

DOE O 440.1B requires DOE elements to inform workers of their rights and responsibilities by appropriate means, including posting the Occupational Safety and Health Protection for DOE Employees poster in the workplace where it is accessible to all workers.

DOE elements are expected to post the DOE worker protection poster in a significant number of places to permit workers the opportunity to observe the information en route to or from their workplace. This expectation applies to all DOE-owned or leased facilities where Federal employees work. In addition to the poster, DOE elements are expected to take other actions to provide relevant information to workers.

In areas where noncompliance with a DOE-prescribed worker protection standard is identified during an oversight inspection, information about the noncompliance should be conveyed to worksite employees. This can be achieved by posting noncompliance information in such areas for five working days or until the noncompliance is corrected, whichever is longer.

Other worker protection posting requirements may be applicable to special situations in specific workplaces. For example, OSHA's confined space standard requires employers to post danger signs or use other equally effective means to inform exposed employees of the existence and location of, and the danger posed by, the confined space. DOE elements should consult the appropriate OSHA regulations for specific posting requirements.

Along with their rights, workers also have several responsibilities. First, they should comply with all worker protection standards and all related rules, regulations, and Orders. In addition, they should

- read the worker protection poster
- wear or use prescribed protective clothing and equipment while working
- report hazardous conditions to the supervisor
- report any job-related injury or illness to the employer, and seek treatment promptly

d. Identify general personal protective equipment (PPE) requirements, functionality and effects of PPE on safety and worker performance for industrial operations.

The following is taken from DOE G 440.1-1A.

When engineering and/or administrative controls have been considered and implemented and are not sufficient to fully protect the worker from a recognized hazard, PPE can be used to supplement these other controls as appropriate. PPE is acceptable as a control method

- to supplement engineering, work practice, and administrative controls when such controls are not feasible or do not adequately reduce the hazard;
- as an interim measure while engineering controls are being developed and implemented;
- during emergencies when engineering controls may not be feasible; and
- during maintenance and other non-routine activities where other controls are not feasible.

The use of PPE can itself create significant worker hazards, such as heat stress, physical and psychological stress, and impaired vision, mobility, and communication. An example would be a worker wearing several layers of clothing, a respirator, gloves, and a helmet while welding or cutting. This arrangement of PPE could prevent the worker from being aware of the environment in the event of a fire or other emergency.

In these situations, engineering and/or administrative controls should be implemented to supplement PPE. Equipment and clothing should be selected that provide an adequate level of protection. The selection process should involve representatives of the affected safety disciplines working in concert. Two basic objectives of any PPE practice should be to protect the wearer from safety and health hazards, and to prevent injury to the wearer from incorrect use and/or malfunction of the PPE. To accomplish these objectives, a comprehensive PPE practice should include hazard identification, medical monitoring, environmental surveillance, selection, use, maintenance, and decontamination of PPE and its associated training.

e. Demonstrate appropriate selection and performance of qualitative and quantitative risk analysis techniques.

- **What If analysis**
- **Preliminary hazard analysis**
- **Fault tree analysis**
- **Failure modes and effects analysis**
- **Energy trace and barrier analysis**
- **Hazard and Operability Analysis (HAZOP)**
- **Process hazard analysis**
- **Root cause analysis**

What If Analysis

The following is taken from the Massachusetts Institute of Technology, Appendix VI, What If Hazard Analysis.

What-if analysis is a structured brainstorming method of determining what things can go wrong and judging the likelihood and consequences of those situations occurring. The answers to these questions form the basis for making judgments regarding the acceptability of those risks and determining a recommended course of action for those risks judged to be unacceptable. An experienced review team can effectively and productively discern major issues concerning a process or system. Led by an energetic and focused facilitator, each member of the review team participates in assessing what can go wrong based on their past experiences and knowledge of similar situations.

Using an operating procedure and/or piping and instrument diagram (P&ID), the team reviews the operation or process step. Team members usually include operating and maintenance personnel, design and/or operating engineers, specific skills as needed and a safety representative. At each step in the procedure or process, What-if questions are asked and answers generated. To minimize the chances that potential problems are not overlooked, moving to recommendations is held until all of the potential hazards are identified.

The review team then makes judgments regarding the likelihood and severity of the “what-if” answers. If the risk indicated by those judgments is unacceptable then a

recommendation is made by the team for further action. The completed analysis is then summarized and prioritized, and responsibilities are assigned.

Preliminary Hazard Analysis

The following is taken from DOE G 440.1-1A.

Preliminary hazard analyses provide a broad hazard screening tool that includes a review of the types of operations that will be performed in the proposed facility and identifies the hazards associated with these types of operations and facilities. The results of the PHA are used to determine the need for additional, more detailed analysis, serve as a precursor where further analysis is deemed necessary, and serve as a baseline hazard analysis where further analysis is not indicated. The PHA is most applicable in the conceptual design stage, but it is also useful for existing facilities and equipment that have not had an adequate baseline hazard analysis. A facility hazard analysis is a detailed study to identify and analyze potential hazards associated with each aspect of the facility and related equipment and operations. The analysis should include a systematic review of each facility component and task.

Fault Tree Analysis

The following is taken from DOE G 440.1-1A.

The FTA is a logic tree used to evaluate a specific undesired event. The FTA is developed through deductive logic from an undesired event to all sub-events that should occur to cause the undesired event. The FTA can be applied at any point in the life of a facility. The FTA can be used to support the PHA during facility design.

Failure Modes and Effects Analysis

The FMEA is a critical review of the system, coupled with a systematic examination of all conceivable failures and an evaluation of the effects of these failures on the mission capability of the system. The FMEA can help avoid costly facility modifications and should be initiated early in the design phase. Once performed, the FMEA provides valuable information if updated throughout the design process.

Energy Trace and Barrier Analysis

The following is taken from DOE G 440.1-1A.

The ETBA identifies potential energy sources, traces those sources to a potential hazard, and determines if the proper barriers to the hazard are in place. The ETBA provides an effective tool to identify potential hazards for the PHA.

Hazard and Operability Analysis

The following is taken from National Aeronautics and Space Administration, NASA 8719.7.

The HAZOP study is a qualitative method of analysis used in identifying risk related to highly hazardous substances. The method provides a means of identifying a multitude of process hazards. It is used to identify potential hazards and operability problems early in the acquisition cycle at the time of design development of a process. Since the method can be applied early, the potential cost needed to eliminate or correct the hazard is

minimized. The HAZOP is performed by an interdisciplinary team of experts who systematically examine each part of a process. This team identifies how deviations from the design intent can occur and whether the collective or individual deviations can create hazards.

The HAZOP is a structured group analysis technique for stimulating the imagination to identify and assess the significance of all the ways a process unit can malfunction or be improperly operated. Its purpose is to identify potential process hazards due to system interactions or exceptional operating conditions.

The analysis objectives are to identify deviations from the design intent of the system. Then the analyst determines the safety concerns associated with the identified deviations. Finally, recommendations are proposed for resolving safety concerns or accepting risk. The HAZOP process is shown in figure 1.

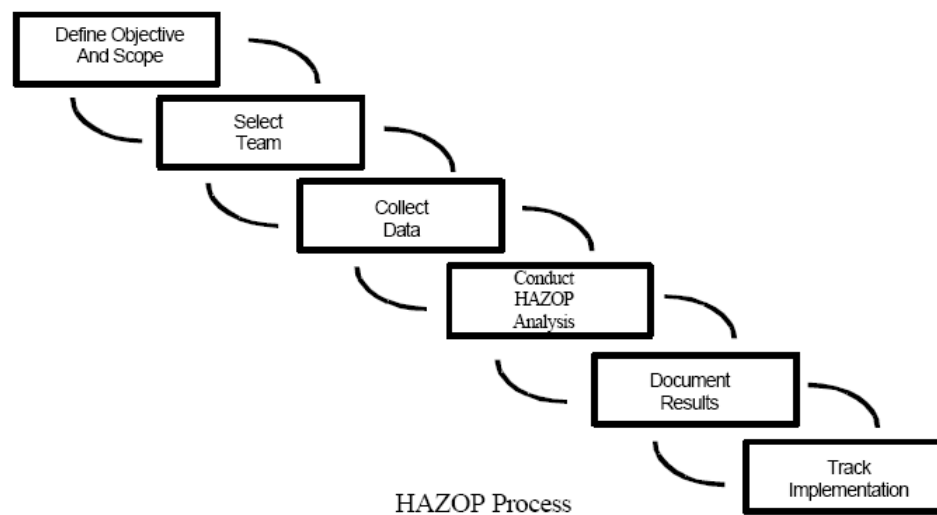

Source: NASA 8719.7

Figure 1. HAZOP Process

Process Hazard Analysis

The following is taken from DOE-HDBK-1100-2004

A PrHA is an organized and systematic method to identify and analyze the significance of potential hazards associated with processing or handling highly hazardous chemicals. A PrHA helps employers and workers to make decisions for improving safety and reducing the consequences of unwanted or unplanned releases of hazardous chemicals. It is used to analyze potential causes and consequences of fires, explosions, releases of toxic or flammable chemicals, and major spills of hazardous chemicals. It focuses on equipment, instrumentation, utilities, routine and non-routine human actions, and external factors that might impact a process.

Root Cause Analysis

The following is taken from DOE-NE-STD-1004-92.

Every root cause investigation and reporting process should include five phases. While there may be some overlap between phases, every effort should be made to keep them separate and distinct.

- **Phase I. Data Collection**

It is important to begin the data collection phase of root cause analysis immediately following the occurrence identification to ensure that data are not lost. The information that should be collected consists of conditions before, during, and after the occurrence; personnel involvement; environmental factors; and other information having relevance to the occurrence.

- **Phase II. Assessment**

Any root cause analysis method may be used that includes the following steps:

1. Identify the problem.
2. Determine the significance of the problem.
3. Identify the causes immediately preceding and surrounding the problem.
4. Identify the reasons why the causes in the preceding step existed, working back to the root cause. This root cause is the stopping point in the assessment phase.

- **Phase III. Corrective Actions**

Implementing effective corrective actions for each cause reduces the probability that a problem will recur and improves reliability and safety.

- **Phase IV. Inform**

Entering the report on the occurrence reporting and processing system (ORPS) is part of the inform process. Also included is discussing and explaining the results of the analysis, including corrective actions, with management and personnel involved in the occurrence. In addition, consideration should be given to providing information of interest to other facilities.

- **Phase V. Follow-up**

Follow-up includes determining if corrective action has been effective in resolving problems. An effectiveness review is essential to ensure that corrective actions have been implemented and are preventing recurrence.

8. Occupational safety personnel must demonstrate the ability to perform occupational safety trend analyses.

a. Discuss key processes used in operation trending, analysis, post-operation activity information, and their relationships to occupational safety activities.

The following is taken from DOE G 414.1-5.

Identified problem findings and their associated causes should also be analyzed to determine the existence of trends to identify the same or similar occurrences, generic problems, vulnerabilities, and cross-functional weaknesses at the lowest level before significant problems result. Trending typically identifies problem categories, responsible organizations, and specific activities or conditions. Benefits of trending include the following:

- Able to document historical data consistently in measurable, visible terms
- Identify changes in performance as they occur

- Develop leading indicators that identify degrading trends

A consistent trend coding system would assist in analyzing the problem findings. This trending data should be constantly analyzed, updated and summarized; and the results should be reported to management.

To assist in analyzing and trending identified problem findings and developing corrective actions, the assessing organization and/or site/organization manager should determine the applicable guiding principles and core safety management functions for ISM outlined in DOE P 450.4 for each finding. This will assist managers in identifying broader causal factors that can reduce the potential for similar problem findings. Input for determining the guiding principles and core functions may be provided by the assessing individual/organization and/or the individuals evaluating each finding and designing applicable corrective actions.

b. Explain the purpose and methods described in 29 CFR 1904, “Recording and Reporting Occupational Injuries and Illnesses” and demonstrate a working ability to compute Total Recordable Cases (TRC) and Days Away, Restricted Time (DART) rates.

The following is taken from 29 CFR 1904.

The purpose of 29 CFR 1904 is to require employers to record and report work-related fatalities, injuries and illnesses.

Compute the incidence rate for all recordable cases of injuries and illnesses using the following formula:

Total number of injuries and illnesses (N) ÷ number of hours worked by all employees (EH) x 200,000 hours = total recordable case rate. (The 200,000 figure in the formula represents the number of hours 100 employees working 40 hours per week, 50 weeks per year would work and provides the standard base for calculating incidence rates.)

The DART rate is calculated using the following formula:

$$N \div EH \times 200,000$$

where:

N = number of illness and/or injuries with days away, restricted work, or job transfer

EH = total hours worked by all employees during calendar year

200,000 = base for 100 full-time equivalent workers (40 hours per week, 50 weeks per year)

c. Determine what type and scope of analysis should be performed and how performance indicators describe the quality of the programs being assessed.

The following is taken from U.S. Department of Labor, Occupational Safety and Health Administration, Safety and Health Management eTool, Worksite Analysis.

Review of the OSHA injury and illness forms is the most common form of trend analysis, but other records of hazards can be analyzed for patterns. Examples are inspection records and employee hazard reporting records.

- Injury and Illness Records Analysis
 - Since there must be enough information for patterns to emerge, small sites may require a review of three–five years of records. Larger sites may find useful trends yearly, quarterly, or monthly.
 - When analyzing injury and illness records, look for similar injuries and illnesses. These generally indicate a lack of hazard controls. Look for where the injury or illness occurred, what type of work was being done, time of day, or type of equipment.
- Analysis of Other Records
 - Repeat hazards, just like repeat injuries or illnesses, mean that controls are not working. And, patterns in hazard identification records can show up over shorter periods of time than accidents or incidents. Upgrading a control may involve something as basic as improving communication or accountability.

Hazards found during worksite analysis should be reviewed to determine what failure in the safety and health system permitted the hazard to occur. The system failure should then be corrected to ensure that similar hazards do not recur.

d. Analyze incident/occurrence report data for a specified period for safety trends or compliance problems and communicate results to workers and management.

This is a performance-based KSA. The Qualifying Official will evaluate its completion.

e. Describe OSHA's injury and illness record keeping and the DOE Computerized Accident/Incident Reporting System (CAIRS) and subsequent uses in safety trending.

The following is taken from 29 CFR 1904.7.

An injury or illness meets the general recording criteria, and is therefore to be recordable, if it results in any of the following: death, days away from work, restricted work or transfer to another job, medical treatment beyond first aid, or loss of consciousness. You must also consider a case to meet the general recording criteria if it involves a significant injury or illness diagnosed by a physician or other licensed health care professional, even if it does not result in death, days away from work, restricted work or job transfer, medical treatment beyond first aid, or loss of consciousness.

The following is taken from the CAIRS Reference Manual.

CAIRS (computerized accident/incident reporting system) is a database used to collect and analyze DOE and DOE contractor reports of injuries, illnesses, and other accidents that occur during DOE operations. CAIRS reporting is managed by the Office of Corporate Safety Analysis (HS-30), with hardware and software support from the Office of Information Management (HS-1.22). The information contained in CAIRS provides a centralized collection of DOE accident data for data users to perform various analyses, including developing trends and identifying potential hazards to help reduce accidents.

CAIRS was originally developed in 1983 for the collection and analysis of accident information, and was hosted on a Hewlett Packard-3000 computer. CAIRS was redesigned as a result of findings from an independent evaluation performed in 1991.

CAIRS was subsequently migrated to a high-performance database, and its capabilities were modernized and enhanced to better serve the changing DOE reporting environment and meet the needs of the growing CAIRS user community. CAIRS now supports the creation and review of basic reports, standard reports, logs, and search and distribution reports.

Access to CAIRS is available to the staff of all DOE organizations and contractors.

The CAIRS database contains individual accident reports from 1983 to the present for injury/illness cases and for vehicle accidents. It also contains property damage cases from 1975 to the present. Statistical data are generated from summary records and are available from 1975 through the present. Please note that reporting thresholds have changed throughout the years, primarily in 1983 and 1996. A complete listing of reporting thresholds and their adjustment dates is included in the online helps.

The CAIRS database also contains exposure data for DOE and DOE contractor organizations, including work hours, property valuation, number of ground fleet vehicles and miles traveled, number of aircraft and hours operated, number of marine craft and hours operated, and number of railroad cars and engine miles traveled.

The type of data found within each module also varies. Standard reports include static reports published by the Office of Corporate Safety Assurance (HS-31). The logs module allows viewing of injury/illness, vehicle accident, and property damage logs from all reporting organizations. Accident forms, exposure information, property damage descriptions, and performance indices are available from the reports module. The search and distribution module allows you to query the individual accident report fields directly and create custom reports.

f. Discuss current DOE efforts to improve and implement leading and lagging indicators, including safety functional areas, organizations collecting performance incentive indicator data, DOE rollup of data and management actions to improve use of indicators.

This is site-specific, time-sensitive KSA. The local Qualifying Official will evaluate its completion.

Mandatory Performance Activities:

g. Evaluate a DOE contractor's safety performance metrics and explain how these represent the effectiveness of the respective safety programs or target specific safety risks.

This is a performance-based KSA. The Qualifying Official will evaluate its completion.

9. Occupational safety personnel must demonstrate a working level knowledge of safety considerations associated with industrial operations.

a. Describe common industrial operations (e.g., maintenance, production, testing, inspection, and setup [both facility and equipment]) and related activities (e.g., welding, material handling, machining, cleaning, and coating), including the hazards and safety interfaces necessary to protect workers and safely perform work.

Maintenance, Production, Testing, and Inspection

The following is taken from the Industrial Accident Prevention Association, Preventive Maintenance.

The hazards associated with maintenance activities can be classified as follows:

- Safety hazards
 - Mechanical
 - equipment
 - tools
 - Electrical
- Live equipment
 - Pneumatic
 - Hydraulic
 - Thermal
 - Combustion
 - Falls
 - slippery floors
 - working at heights
- Health Hazards
 - Chemical Agents
 - process chemicals
 - cleaning solvents
 - unexpected reaction products
 - dusts
 - other chemical agents
 - Physical Agents
 - noise
 - vibration
 - other

Production

- Poorly designed tools
- Hard to access work locations
- Ill fitting PPE
- Complex procedures

Many of these hazards are interrelated. Examine the process, the layout of the process area, and the process equipment used, to determine the exact nature of the hazards likely to be encountered during maintenance activities. For example, maintenance work carried out in confined spaces carries a greater risk of critical injuries and acute exposures to chemical and physical agents. These risks are associated with equipment and materials in the space itself and from nearby operations. Fatalities are quite common.

Ideally, the hazards likely to occur during maintenance activities should be addressed in the planning stage.

Setup

Depending on the nature of the process, special precautions may be needed to protect workers when disassembling and cleaning equipment. Consider the following factors that contribute to the level of risk of maintenance activities:

- How easy temporary structures are to erect
- How easy they are to access
- How much disassembly is required to access affected equipment
- Need for temporary hoisting equipment
- Need for PPE
- Housekeeping hazards created at floor level by the presence of dismantled components
- Ergonomic Hazards
 - Biomechanical
 - lifting, pushing, pulling (manual handling)
 - stretching, ending (to reach hard to access areas)

Welding

The following is taken from U.S. Department of Labor, Occupational Safety and Health Administration, Welding Health Hazards.

Chemical Agents

Zinc

Zinc is used in large quantities in the manufacture of brass, galvanized metals, and various other alloys. Inhalation of zinc oxide fumes can occur when welding or cutting on zinc-coated metals. Exposure to these fumes is known to cause metal fume fever. Symptoms of metal fume fever are very similar to those of common influenza. They include fever, chills, nausea, dryness of the throat, cough, fatigue, and general weakness and aching of the head and body. The victim may sweat profusely for a few hours, after which the body temperature begins to return to normal. The symptoms of metal fume fever have rarely, if ever, lasted beyond 24 hours. The subject can then appear to be more susceptible to the onset of this condition on Mondays or on weekdays following a holiday than they are on other days.

Cadium

Cadmium is used frequently as a rust-preventive coating on steel and also as an alloying element. Acute exposures to high concentrations or cadmium fumes can produce severe lung irritation, pulmonary edema, and in some cases, death. Long-term exposure to low levels of cadmium in air can result in emphysema and can damage the kidneys. Cadmium is classified by OSHA, NIOSH, and EPA as a potential human carcinogen.

Beryllium

Beryllium is sometimes used as an alloying element with copper and other base metals. Acute exposure to high concentrations of beryllium can result in chemical pneumonia. Long-term exposure can result in shortness of breath, chronic cough, and significant weight loss, accompanied by fatigue and general weakness.

Iron Oxide

Iron is the principal alloying element in steel manufacture. During the welding process, iron oxide fumes arise from both the base metal and the electrode. The primary acute effect of this exposure is irritation of nasal passages, throat, and lungs. Although long-term exposure to iron oxide fumes may result in iron pigmentation of the lungs, most authorities agree that these iron deposits in the lung are not dangerous.

Mercury

Mercury compounds are used to coat metals to prevent rust or inhibit foliage growth (marine paints). Under the intense heat of the arc or gas flame, mercury vapors will be produced. Exposure to these vapors may produce stomach pain, diarrhea, kidney damage, or respiratory failure. Long-term exposure may produce tremors, emotional instability, and hearing damage.

Lead

The welding and cutting of lead-bearing alloys or metals whose surfaces have been painted with lead-based paint can generate lead oxide fumes. Inhalation and ingestion of lead oxide fumes and other lead compounds will cause lead poisoning. Symptoms include metallic taste in the mouth, loss of appetite, nausea, abdominal cramps, and insomnia. In time, anemia and general weakness, chiefly in the muscles of the wrists, develop. Lead adversely affects the brain, central nervous system, circulatory system, reproductive system, kidneys, and muscles.

Fluorides

Fluoride compounds are found in the coatings of several types of fluxes used in welding. Exposure to these fluxes may irritate the eyes, nose, and throat. Repeated exposure to high concentrations of fluorides in air over a long period may cause pulmonary edema (fluid in the lungs) and bone damage. Exposure to fluoride dusts and fumes has also produced skin rashes.

Chlorinated Hydrocarbon Solvents

Various chlorinated hydrocarbons are used in degreasing or other cleaning operations. The vapors of these solvents are a concern in welding and cutting because the heat and ultraviolet (UV) radiation from the arc will decompose the vapors and form highly toxic and irritating phosgene gas.

Phosgene

Phosgene is formed by decomposition of chlorinated hydrocarbon solvents by UV radiation. It reacts with moisture in the lungs to produce hydrogen chloride, which in turn destroys lung tissue. For this reason, any use of chlorinated solvents should be well away from welding operations or any operation in which UV radiation or intense heat is generated.

Carbon Monoxide

Carbon monoxide is a gas usually formed by the incomplete combustion of various fuels. Welding and cutting may produce significant amounts of carbon monoxide. In addition, welding operations that use carbon dioxide as the inert gas shield may produce hazardous concentrations of carbon monoxide in poorly ventilated areas. This is caused by a breakdown of shielding gas. Carbon monoxide is odorless, colorless and tasteless and

cannot be readily detected by the senses. Common symptoms of overexposure include pounding of the heart, a dull headache, flashes before the eyes, dizziness, ringing in the ears, and nausea.

Ozone

Ozone (is produced by ultraviolet light from the welding arc. Ozone is produced in greater quantities by gas metal arc welding, gas tungsten arc welding, and plasma arc cutting. Ozone is a highly active form of oxygen and can cause great irritation to all mucous membranes. Symptoms of ozone exposure include headache, chest pain, and dryness of the upper respiratory tract. Excessive exposure can cause fluid in the lungs. Nitrogen dioxide and ozone are thought to have long-term effects on the lungs.

Nitrogen Oxides

The UV light of the arc can produce nitrogen oxides, from the nitrogen and oxygen in the air. Nitrogen oxides are produced by gas metal arc welding, gas tungsten arc welding, and plasma arc cutting. Even greater quantities are formed if the shielding gas contains nitrogen. Nitrogen dioxide, one of the oxides formed, has the greatest health effect. This gas is irritating to the eyes, nose and throat but dangerous concentrations can be inhaled without any immediate discomfort. High concentrations can cause shortness of breath, chest pain, and fluid in the lungs.

Physical Agents

Ultraviolet Radiation

UV radiation is generated by the electric arc in the welding process. Skin exposure to UV can result in severe burns, in many cases without prior warning. UV radiation can also damage the lens of the eye. Many arc welders are aware of the condition known as “arc-eye,” a sensation of sand in the eyes. This condition is caused by excessive eye exposure to UV. Exposure to UV rays may also increase the skin effects of some industrial chemicals (coal tar and cresol compounds, for example).

Infrared Radiation

Exposure to infrared (IR) radiation, produced by the electric arc and other flame cutting equipment may heat the skin surface and the tissues immediately below the surface. Except for this effect, which can progress to thermal burns in some situations, IR radiation is not dangerous to welders. Most welders protect themselves from IR (and UV) radiation with a welder’s helmet (or glasses) and protective clothing.

Intense Visible Light

Exposure of the human eye to intense visible light can produce adaptation, pupillary reflex, and shading of the eyes. Such actions are protective mechanisms to prevent excessive light from being focused on the retina. In the arc welding process, eye exposure to intense visible light is prevented for the most part by the welder’s helmet. However, some individuals have sustained retinal damage due to careless viewing of the arc. At no time should the arc be observed without eye protection.

Material Handling

The following is taken from U.S. Department of Labor, Occupational Safety and Health Administration, Materials Handling and Storage.

Handling and storing materials involves diverse operations such as hoisting tons of steel with a crane, driving a truck loaded with concrete blocks, manually carrying bags and material, and stacking drums, barrels, kegs, lumber, or loose bricks.

The efficient handling and storing of materials is vital to industry. These operations provide a continuous flow of raw materials, parts, and assemblies through the workplace, and ensure that materials are available when needed. Yet, the improper handling and storing of materials can cause costly injuries.

Workers frequently cite the weight and bulkiness of objects being lifted as major contributing factors to their injuries. In 1990, back injuries resulted in 400,000 workplace accidents. The second factor frequently cited by workers as contributing to their injuries was body movement. Bending, followed by twisting and turning, were the more commonly cited movements that caused back injuries. Back injuries accounted for more than 20 percent of all occupational illnesses, according to data from the National Safety Council.

In addition, workers can be injured by falling objects, improperly stacked materials, or by various types of equipment. When manually moving materials, however, workers should be aware of potential injuries, including the following:

- Strains and sprains from improperly lifting loads, or from carrying loads that are either too large or too heavy
- Fractures and bruises caused by being struck by materials, or by being caught in pinch points
- Cuts and bruises caused by falling materials that have been improperly stored, or by incorrectly cutting ties or other securing devices.

Since numerous injuries can result from improperly handling and storing materials, it is important to be aware of accidents that may occur from unsafe or improperly handled equipment and improper work practices, and to recognize the methods for eliminating, or at least minimizing, the occurrence of those accidents. Consequently, employers and employees can and should examine their workplaces to detect any unsafe or unhealthful conditions, practices, or equipment and take the necessary steps to correct them.

Methods of Prevention

General safety principles can help reduce workplace accidents. These include work practices, ergonomic principles, and training and education. Whether moving materials manually or mechanically, employees should be aware of the potential hazards associated with the task at hand and know how to exercise control over their workplaces to minimize the danger.

Moving, Handling, and Storing Materials

When manually moving materials, employees should seek help when a load is so bulky it cannot be properly grasped or lifted, when they cannot see around or over it, or when a load cannot be safely handled.

When an employee is placing blocks under raised loads, the employee should ensure that the load is not released until his or her hands are clearly removed from the load. Blocking materials and timbers should be large and strong enough to support the load safely.

Materials with evidence of cracks, rounded corners, splintered pieces, or dry rot should not be used for blocking.

Handles and holders should be attached to loads to reduce the chances of getting fingers pinched or smashed. Workers also should use appropriate protective equipment. For loads with sharp or rough edges, wear gloves or other hand and forearm protection. To avoid injuries to the hands and eyes, use gloves and eye protection. When the loads are heavy or bulky, the mover should also wear steel-toed safety shoes or boots to prevent foot injuries if the worker slips or accidentally drops a load.

When mechanically moving materials, avoid overloading the equipment by letting the weight, size, and shape of the material being moved dictate the type of equipment used for transporting it. All materials handling equipment has rated capacities that determine the maximum weight the equipment can safely handle and the conditions under which it can handle those weights. The equipment-rated capacities must be displayed on each piece of equipment and must not be exceeded except for load testing. When picking up items with a powered industrial truck, the load must be centered on the forks and as close to the mast as possible to minimize the potential for the truck tipping or the load falling. A lift truck must never be overloaded because it would be hard to control and could easily tip over. Extra weight must not be placed on the rear of a counterbalanced forklift to offset an overload. The load must be at the lowest position for traveling, and the truck manufacturer's operational requirements must be followed. All stacked loads must be correctly piled and cross-tiered, where possible. Precautions also should be taken when stacking and storing material.

Stored materials must not create a hazard. Storage areas must be kept free from accumulated materials that may cause tripping, fires, or explosions, or that may contribute to the harboring of rats and other pests. When stacking and piling materials, it is important to be aware of such factors as the materials' height and weight, how accessible the stored materials are to the user, and the condition of the containers where the materials are being stored.

All bound material should be stacked, placed on racks, blocked, interlocked, or otherwise secured to prevent it from sliding, falling, or collapsing. A load greater than that approved by a building official may not be placed on any floor of a building or other structure. Where applicable, load limits approved by the building inspector should be conspicuously posted in all storage areas.

When stacking materials, height limitations should be observed. For example, lumber must be stacked no more than 16 feet high if it is handled manually; 20 feet is the maximum stacking height if a forklift is used. For quick reference, walls or posts may be painted with stripes to indicate maximum stacking heights.

Used lumber must have all nails removed before stacking. Lumber must be stacked and leveled on solidly supported bracing. The stacks must be stable and self-supporting. Stacks of loose bricks should not be more than 7 feet in height. When these stacks reach a height of 4 feet, they should be tapered back 2 inches for every foot of height above the 4-foot level. When masonry blocks are stacked higher than 6 feet, the stacks should be tapered back one-half block for each tier above the 6-foot level.

Bags and bundles must be stacked in interlocking rows to remain secure. Bagged material must be stacked by stepping back the layers and cross-keying the bags at least every ten layers. To remove bags from the stack, start from the top row first. Baled paper and rags stored inside a building must not be closer than 18 inches to the walls, partitions, or sprinkler heads. Boxed materials must be banded or held in place using cross-ties or shrink plastic fiber.

Drums, barrels, and kegs must be stacked symmetrically. If stored on their sides, the bottom tiers must be blocked to keep them from rolling. When stacked on end, put planks, sheets of plywood dunnage, or pallets between each tier to make a firm, flat, stacking surface. When stacking materials two or more tiers high, the bottom tier must be chocked on each side to prevent shifting in either direction.

When stacking, consider the need for availability of the material. Material that cannot be stacked due to size, shape, or fragility can be safely stored on shelves or in bins. Structural steel, bar stock, poles, and other cylindrical materials, unless in racks, must be stacked and blocked to prevent spreading or tilting. Pipes and bars should not be stored in racks that face main aisles; this could create a hazard to passers-by when supplies are being removed.

Using Materials Handling Equipment

To reduce potential accidents associated with workplace equipment, employees need to be trained in the proper use and limitations of the equipment they operate.

Powered Industrial Trucks

Workers who must handle and store materials often use fork trucks, platform lift trucks, motorized hand trucks, and other specialized industrial trucks powered by electrical motors or internal combustion engines. Affected workers, therefore, should be aware of the safety requirements pertaining to fire protection, and the design, maintenance, and use of these trucks.

All new powered industrial trucks, except vehicles intended primarily for earth moving or over-the-road hauling, shall meet the design and construction requirements for powered industrial trucks established in ANSI B56.1-1969, *Safety Standard for Powered Industrial Trucks*. Approved trucks shall also bear a label or some other identifying mark indicating acceptance by a nationally recognized testing laboratory.

Modifications and additions that affect capacity and safe operation of the trucks shall not be performed by an owner or user without the manufacturer's prior written approval. In these cases, capacity, operation, and maintenance instruction plates and tags or decals must be changed to reflect the new information. If the truck is equipped with front-end attachments that are not factory installed, the user should request that the truck be marked to identify these attachments and show the truck's approximate weight, including the installed attachment, when it is at maximum elevation with its load laterally centered.

There are eleven different types of industrial trucks or tractors, some having greater safeguards than others. There are also designated conditions and locations under which the vast range of industrial-powered trucks can be used. In some instances, powered industrial trucks cannot be used, and in others, they can only be used if approved by a

nationally recognized testing laboratory for fire safety. For example, powered industrial trucks must not be used in atmospheres containing concentrations of hazardous substances.

These trucks are not to be used in atmospheres containing hazardous concentrations of metal dust, including aluminum, magnesium, and other metals of similarly hazardous characteristics or in atmospheres containing carbon black, coal, or coke dust. Where dust of magnesium, aluminum, or aluminum bronze dusts may be present, the fuses, switches, motor controllers, and circuit breakers of trucks must be enclosed with enclosures approved for these substances.

There also are powered industrial trucks or tractors that are designed, constructed, and assembled for use in atmospheres containing flammable vapors or dusts. These include industrial-powered trucks equipped with additional safeguards to their exhaust, fuel, and electrical systems; with no electrical equipment, including the ignition; with temperature limitation features; and with electric motors and all other electrical equipment completely enclosed.

These specially designed powered industrial trucks may be used in locations where volatile flammable liquids or flammable gases are handled, processed, or used. The liquids, vapors, or gases should, among other things, be confined within closed containers or closed systems from which they cannot escape.

Ergonomic Safety and Health Principles

Ergonomics includes restructuring or changing workplace conditions to make the job easier and reducing/stressors that cause cumulative trauma disorders and repetitive motion injuries. In the area of materials handling and storing, ergonomic principles may require controls such as reducing the size or weight of the objects lifted, installing a mechanical lifting aid, or changing the height of a pallet or shelf.

Although no approach has been found for totally eliminating back injuries resulting from lifting materials, a substantial number of lifting injuries can be prevented by implementing an effective ergonomics program and by training employees in appropriate lifting techniques.

In addition to using ergonomic controls, there are some basic safety principles that can be employed to reduce injuries resulting from handling and storing materials. These include taking general fire safety precautions and keeping aisles and passageways clear.

In adhering to fire safety precautions, employees should note that flammable and combustible materials must be stored according to their fire characteristics. Flammable liquids, for example, must be separated from other material by a fire wall. Also, other combustibles must be stored in an area where smoking and using an open flame or a spark-producing device is prohibited. Dissimilar materials that are dangerous when they come into contact with each other must be stored apart.

When using aisles and passageways to move materials mechanically, sufficient clearance must be allowed for aisles at loading docks, through doorways, wherever turns must be made, and in other parts of the workplace. Providing sufficient clearance for mechanically moved materials will prevent workers from being pinned between the

equipment and fixtures in the workplace, such as walls, racks, posts, or other machines. Sufficient clearance also will prevent the load from striking an obstruction and falling on an employee.

All passageways used by employees should be kept clear of obstructions and tripping hazards. Materials in excess of supplies needed for immediate operations should not be stored in aisles or passageways, and permanent aisles and passageways must be marked appropriately.

Cleaning

The following is taken from the International Labour Organization, *Cleaner*.

Cleaners often work dangerously close to moving machinery, conveyors and in-plant vehicles which may result in serious accidents. During cleaning, the floors are often wet and slippery, and cleaners may slip, trip, or fall. Cleaners extensively use cleaning, rinsing and other chemicals, which may cause irritation and other problems in their eyes, nose, throat, and skin. The cleaner's work is often done in uncomfortable postures, involves handling of heavy loads, and includes continuous repetitive movements. All these may lead to serious problems of the back, hands, and arms, etc.

Preventive measures include the following:

- Inspect ladder before climbing. Never climb on a shaky ladder or a ladder with slippery rungs.
- Wear safety shoes with non-skid soles.
- Do not handle or touch hot (or those that may be hot) articles or surfaces with bare hands; if needed, wear heat-protective gloves.
- Wear a respirator if working in a dusty area.
- Protect hands with chemical-resistant gloves; if impractical, use a barrier cream.
- Do not use hydrochloric acid, except with extreme caution. Do not allow skin contact; do not expose eyes to vapors and do not inhale or ingest. Receive instructions on how to handle safely, if necessary and what to do if spillage occurs.
- Control pests through periodic visits of pest exterminator, or special visits in case of heavy infestation.
- Select a shift work schedule that would have the least harmful effect on the employee's health, family and personal life—consult employees and a specialist in shift scheduling.
- Do not work alone on premises on which a danger of assault exists, in particular on an evening or night shift. Determine how to summon help, if needed.

Coating

The following is taken from Unified Facilities Guide Specifications, UFGS-33 52 80, *Liquid Fuels Pipeline Coating Systems*.

Ensure that employees are trained in all aspects of the safety plan. Specified coatings may have potential health hazards if ingested or improperly handled. The coating manufacturer's written safety precautions shall be followed throughout mixing, application, and curing of the coatings. During all cleaning, cleanup, surface preparation, and paint application phases, ensure that employees are protected from toxic and

hazardous chemical agents that exceed concentrations in 29 CFR 1910.1000, “Air Contaminants.” Comply with respiratory protection requirements in 29 CFR 1910.134, “Respiratory Protection.”

b. Describe safety considerations associated with placement of operations and equipment (i.e., location of personnel in the proximity of moving equipment or parts, traffic patterns, and structural support for equipment).

The following is taken from the Industrial Accident Prevention Association, Preventive Maintenance.

Equipment Selection

The process will determine the type of equipment to be used. However, consider the following:

- Reliability
 - Manufacturer’s data
 - In-plant operating experience
 - Trade association data
- Ease of access to serviceable parts
- Ease of disassembly
- Complexity of repair procedures
- Ease of frequency of required lubrication
- Manufacturer/supplier follow-up
 - Availability of parts
 - Availability of service time

When servicing equipment, hazards not related to the process operation are likely to be introduced. For this reason, it is important to prepare written servicing procedures that include the following:

- A clear, step-by-step procedure, in checklist form, for controlling hazardous energy
- Hazards identification
- Selection and specification of PPE
- Selection and specification of tools to be used
- Step-by-step procedure for disassembly
- Step-by-step checklist for inspection of components
- Identification of hazards associated with sub-procedures
- Erection and disassembly of scaffolding and other temporary platforms
- Disassembly of small-scale equipment
- Reassembly of small-scale equipment
- Support and disassembly of large scale equipment

The following is taken from 30 CFR 57.14107.

Moving machine parts shall be guarded to protect persons from contacting gears, sprockets, chains, drive, head, tail, and take-up pulleys, flywheels, coupling, shafts, fan blades; and similar moving parts that can cause injury.

Guards shall not be required where the exposed moving parts are at least seven feet away from walking or working surfaces.

Structural Supports for Equipment

The following is taken from DOE-HDBK-1132-99.

Equipment supports are designed to avoid resonance resulting from the harmony between the natural frequency of the structure and the operating frequency of reciprocating or rotating equipment supported on the structure. Resonance effects may be minimized by designing equipment isolation supports to reduce the dynamic transmission of the applied load to as low a level as can be economically achieved.

c. Outline point of operation hazards associated with workplace equipment and describe appropriate machine guarding principles.

The following is taken from U.S. Department of Labor, Occupational Safety and Health Administration, Hazards Associated with the Unintended (Double) Cycling of Mechanical Power Presses.

29 CFR 1910.217, “Mechanical Power Presses,” contains requirements to protect workers from point of operation hazards. Requirements that apply to power presses include the following:

- Hand Controls. Controls must be arranged so that both hands are used at the same time to trip the press.
- Anti-repeat. This feature must be part of the control system so that the press is limited to a single stroke.
- Electrical Clutch/Brake Control Circuits. Circuitry must incorporate features such as relays, limit switches, and static output circuits to minimize the possibility of an unintended stroke if a control component fails to function properly.
- Control Reliability. The control system must be designed to allow the brake to stop the press when a control component fails, while at the same time not allowing the next stroke to occur until the failure is fixed.
- Safeguarding the Point of Operation. Employers shall provide and ensure the use of point of operation guards or properly applied and adjusted point of operation devices on every operation performed on a mechanical power press.
- Point of Operation Guards. A barrier that prevents the operator’s hand or fingers from entering the point of operation of the press by reaching through, over, under or around the guard.
- Point of Operation Devices. A control or attachment that prevents the operator from inadvertently reaching into the point of operation.
- Hand Feeding Tools. Used for placing and removing material in and from the point of operation area. These can only be used with other point of operation guards or devices, not in place of them.

The following is taken from 29 CFR 1910.212.

Machine Guarding

Types of guarding. One or more methods of machine guarding shall be provided to protect the operator and other employees in the machine area from hazards such as those created by point of operation, ingoing nip points, rotating parts, flying chips and sparks. Examples of guarding methods are: barrier guards, two-hand tripping devices, electronic safety devices, etc.

General requirements for machine guards. Guards shall be affixed to the machine where possible and secured elsewhere if for any reason attachment to the machine is not possible. The guard shall be such that it does not offer an accident hazard in itself.

Point of operation guarding. Point of operation is the area on a machine where work is actually performed upon the material being processed.

The point of operation of machines whose operation exposes an employee to injury, shall be guarded. The guarding device shall be in conformity with any appropriate standards therefore, or, in the absence of applicable specific standards, shall be so designed and constructed as to prevent the operator from having any part of his body in the danger zone during the operating cycle.

Special hand tools for placing and removing material shall be such as to permit easy handling of material without the operator placing a hand in the danger zone. Such tools shall not be in lieu of other guarding required by this section, but can only be used to supplement protection provided.

Barrels, containers, and drums. Revolving drums, barrels, and containers shall be guarded by an enclosure which is interlocked with the drive mechanism, so that the barrel, drum, or container cannot revolve unless the guard enclosure is in place.

Exposure of blades. When the periphery of the blades of a fan is less than seven (7) feet above the floor or working level, the blades shall be guarded. The guard shall have openings no larger than one-half inch.

Anchoring fixed machinery. Machines designed for a fixed location shall be securely anchored to prevent walking or moving.

d. Describe common concerns and associated control measures that must be addressed in the workplace environment (e.g., noise, thermal burn hazards, heat stress, vibration, eye hazards, workplace illumination, and lasers).

Noise

The following is taken from 29 CFR 1910.95.

Exposure shall be provided when the sound levels exceed those shown in 29 CFR 1910.95, table G-16 when measured on the A scale of a standard sound level meter at slow response. When noise levels are determined by octave band analysis, the equivalent A-weighted sound level may be determined as illustrated in figure 2.

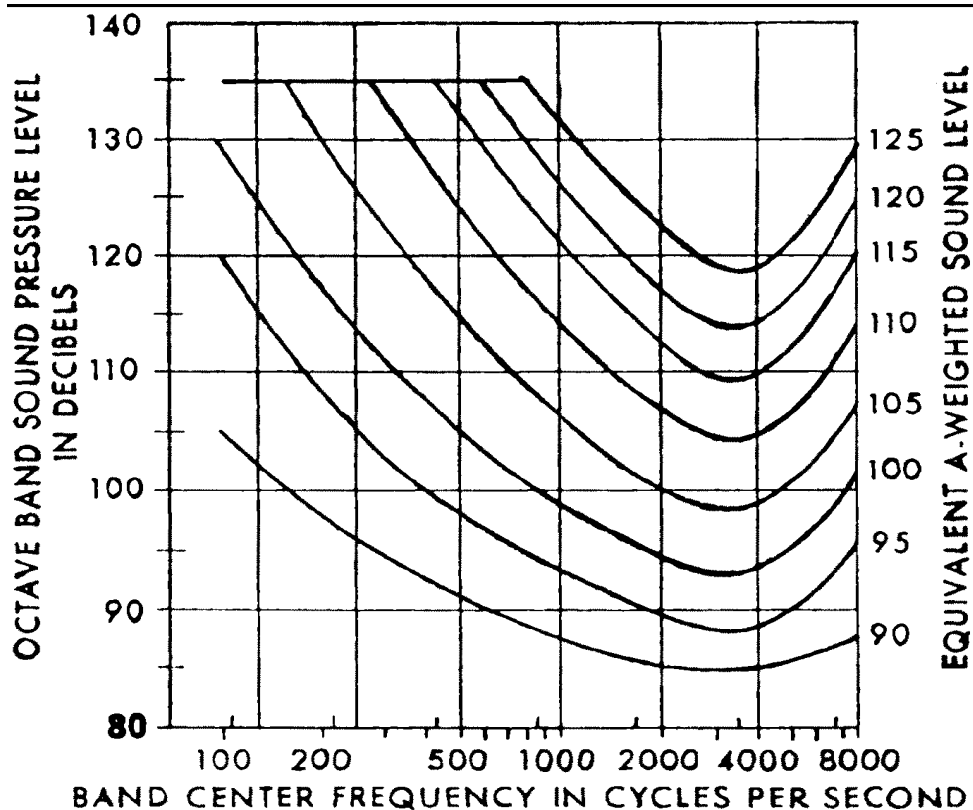

Source: 29 CFR 1910.95

Figure 2. A-weighted sound levels

Equivalent sound level contours. Octave band sound pressure levels may be converted to the equivalent A-weighted sound level by plotting them on figure 2 and noting the A-weighted sound level corresponding to the point of highest penetration into the sound level contours. This equivalent A-weighted sound level, which may differ from the actual A-weighted sound level of the noise, is used to determine exposure limits from table 2.

When employees are subjected to sound exceeding those listed in table 2, feasible administrative or engineering controls should be used. If such controls fail to reduce sound levels within the levels of table 2, PPE shall be provided and used to reduce sound levels within the levels of the table.

If the variations in noise level involve maxima at intervals of one second or less, it is to be considered continuous.

Table 2. Permissible noise exposures

Duration per day, hours	Sound level dBA slow response
8	90
6	92
4	95
3	97
2	100
1 1/2	102
1	105
1/2	110
1/4	115

Source: 29 CFR 1910.95

The employer shall administer a continuing, effective hearing conservation program whenever employee noise exposures equal or exceed an 8-hour time-weighted average sound level of 85 decibels measured on the A scale or, equivalently, a dose of fifty percent. For purposes of the hearing conservation program, employee noise exposures shall be computed in accordance with 29 CFR 1910.95, appendix A and table G-16a, and without regard to any attenuation provided by the use of PPE.

Thermal Burn Hazards

The following is taken from U.S. Department of Labor, Occupational Safety and Health Administration, Thermal Burns.

Potential thermal burn hazard is possible burns due to contact with hot equipment or exposure to high temperatures. To protect workers provide guarding and/or insulation to protect against accidental contact with hot surfaces.

Heat Stress

The following is taken from U.S. Department of Labor, Occupational Safety and Health Administration, OSHA Technical Manual, Heat Stress.

Operations involving high air temperatures, radiant heat sources, high humidity, direct physical contact with hot objects, or strenuous physical activities have a high potential for inducing heat stress in employees engaged in such operations. Such places include: iron and steel foundries, nonferrous foundries, brick-firing and ceramic plants, glass products facilities, rubber products factories, electrical utilities (particularly boiler rooms), bakeries, confectioneries, commercial kitchens, laundries, food canneries, chemical plants, mining sites, smelters, and steam tunnels.

Outdoor operations conducted in hot weather, such as construction, refining, asbestos removal, and hazardous waste site activities, especially those that require workers to wear semipermeable or impermeable protective clothing, are also likely to cause heat stress among exposed workers.

Training is the key to good work practices. Unless all employees understand the reasons for using new, or changing old, work practices, the chances of such a program succeeding are greatly reduced.

NIOSH (1986) states that a good heat stress training program should include at least the following components:

- Knowledge of the hazards of heat stress
- Recognition of predisposing factors, danger signs, and symptoms
- Awareness of first-aid procedures for, and the potential health effects of, heat stroke
- Employee responsibilities in avoiding heat stress
- Dangers of using drugs, including therapeutic ones, and alcohol in hot work environments
- Use of protective clothing and equipment
- Purpose and coverage of environmental and medical surveillance programs and the advantages of worker participation in such programs

Hot jobs should be scheduled for the cooler part of the day, and routine maintenance and repair work in hot areas should be scheduled for the cooler seasons of the year.

Worker Monitoring Programs

Every worker who works in extraordinary conditions that increase the risk of heat stress should be personally monitored. These conditions include wearing semipermeable or impermeable clothing when the temperature exceeds 21°C (69.8°F), working at extreme metabolic loads (greater than 500 kcal/hour), etc.

Personal monitoring can be done by checking the heart rate, recovery heart rate, oral temperature, or extent of body water loss.

To check the heart rate, count the radial pulse for 30 seconds at the beginning of the rest period. If the heart rate exceeds 110 beats per minute, shorten the next work period by one third and maintain the same rest period.

The recovery heart rate can be checked by comparing the pulse rate taken at 30 seconds (P1) with the pulse rate taken at 2.5 minutes (P3) after the rest break starts.

Oral temperature can be checked with a clinical thermometer after work but before the employee drinks water. If the oral temperature taken under the tongue exceeds 37.6°C, shorten the next work cycle by one third.

Body water loss can be measured by weighing the worker on a scale at the beginning and end of each work day. The worker's weight loss should not exceed 1.5 percent of total body weight in a work day. If a weight loss exceeding this amount is observed, fluid intake should increase.

Administrative Controls

The following administrative controls can be used to reduce heat stress:

- Reduce the physical demands of work.
- Provide recovery areas.
- Use shifts.

- Use intermittent rest periods with water breaks.
- Use relief workers.
- Use worker pacing.
- Assign extra workers and limit worker occupancy, or the number of workers present, especially in confined or enclosed spaces.

Vibration

The following is taken from the Canadian Centre for Occupational Health and Safety, *Vibration—Health Effects*.

Vibration-induced health conditions progress slowly. In the beginning it starts as a pain. As the vibration exposure continues, the pain may develop into an injury or disease. Pain is the first health condition that is noticed and should be addressed in order to stop the injury.

Vibration-induced white finger (VWF) is the most common condition among the operators of hand-held vibrating tools. Vibration can cause changes in tendons, muscles, bones and joints, and can affect the nervous system. Collectively, these effects are known as hand-arm vibration syndrome (HAVS). The symptoms of VWF are aggravated when the hands are exposed to cold.

Workers affected by HAVS commonly report

- attacks of whitening (blanching) of one or more fingers when exposed to cold
- tingling and loss of sensation in the fingers
- loss of light touch
- pain and cold sensations between periodic white finger attacks
- loss of grip strength
- bone cysts in fingers and wrists

The development of HAVS is gradual and increases in severity over time. It may take a few months to several years for the symptoms of HAVS to become clinically noticeable.

Eye Hazards

The following is taken from *All About Eye Safety, Eye Safety in the Workplace*.

Potential eye hazards can be found in nearly every industry, but the Bureau of Labor Standards reported that more than 40 percent of injuries studied occurred among craft workers, mechanics, repairers, carpenters, and plumbers. Over a third of the injured workers were operatives, such as assemblers, sanders, and grinding machine operators. Laborers suffered about one-fifth of the eye injuries. Almost half the injured workers were employed in manufacturing; slightly more than 20 percent were in construction.

OSHA standards require that employers provide workers with suitable eye protection. To be effective, the eyewear must be of the appropriate type for the hazard encountered and properly fitted. For example, the Bureau of Labor Standards survey showed that 94 percent of the injuries to workers wearing eye protection resulted from objects or chemicals going around or under the protector. Eye protective devices should allow for air to circulate between the eye and the lens. Only 13 workers injured while wearing eye protection reported breakage.

Nearly one-fifth of the injured workers with eye protection wore face shields or welding helmets. However, only six percent of the workers injured while wearing eye protection wore goggles, which generally offer better protection for the eyes. Best protection is afforded when goggles are worn with face shields.

Workplace Illumination

The following is taken from 29 CFR 1910.56.

Construction areas, ramps, runways, corridors, offices, shops, and storage areas shall be lighted to not less than the minimum illumination intensities listed in table 3 while any work is in progress:

Table 3. Minimum illumination intensities in foot candles

Foot Candles	Area or Operation
5	General construction area lighting
3	General construction areas, concrete placement, excavation and waste areas, accessways, active storage areas, loading platforms, refueling, and field maintenance areas
5	Indoors: warehouses, corridors, hallways, and exitways
5	Tunnels, shafts, and general underground work areas (Exception: minimum of 10 foot-candles is required at tunnel and shaft heading during drilling, mucking, and scaling. Bureau of Mines-approved cap lights shall be acceptable for use in the tunnel heading.)
10	General construction plant and shops (e.g., batch plants, screening plants, mechanical and electrical equipment rooms, carpenter shops, rigging lofts and active storerooms, barracks or living quarters, locker or dressing rooms, mess halls, and indoor toilets and workrooms)
30	First-aid stations, infirmaries, and offices

Source: 29 CFR 1910.56

Other areas. For areas or operations not covered above, refer to the American National Standard A11.1-1965, R1970, *Practice for Industrial Lighting*, for recommended values of illumination.

Lasers

The following is taken from U.S. Department of Labor, Occupational Safety and Health Administration, Guidelines for Laser Safety and Hazard Assessment.

Laser radiation of sufficient intensity and exposure time can cause irreversible damage to the skin and eye of humans. The most common cause of laser-induced tissue damage is thermal in nature. The process is one where the tissue proteins are denatured due to the temperature rise following absorption of laser energy. The thermal damage process is generally associated with lasers operating at exposure times greater than 10 microseconds and in the wavelength region from the near ultraviolet to the far infrared.

Other damage mechanisms have also been demonstrated for other specific wavelength ranges and/or exposure times. For example, photochemical reactions are the principal

cause of tissue damage following exposures to either actinic UV radiation for any exposure time or short-wave visible radiation when exposures are greater than 10 seconds. Tissue damage may also be caused by thermally induced acoustic-shock waves following exposures to very short-time laser exposures.

The principal tissue damage mechanism for repetitively pulsed or scanned laser exposures is still in question. Current evidence would indicate that the major mechanism is a thermal process wherein the effects of the individual pulses are additive. There appears to be a different damage process for repetitively pulsed laser exposures when the individual pulses are shorter than 10 microseconds than when the pulses are longer. Acute and chronic exposures to all forms of optical radiation can produce skin damage of varying degrees.

Numerous types of lasers have been explored rather extensively for the treatment of skin disorders. Certainly, skin injury is of lesser importance than eye damage; however, with the expanding use of higher-power laser systems, the unprotected skin of personnel using lasers may be exposed more frequently to hazardous levels.

Potential hazards associated with compressed gases, cryogenic materials, toxic and carcinogenic materials and noise should be considered. Adequate ventilation shall be installed to reduce noxious or potentially hazardous fumes and vapors, produced by laser welding, cutting, and other target interactions, to levels below the appropriate threshold limit values (TLVs).

e. Address the following confined space hazard considerations for industrial operations:

- **Describe the characteristics of a confined space hazard.**
- **Identify potential construction related confined space locations.**
- **Identify and discuss the application of confined space entry procedures.**

The following descriptions are taken from U.S. Department of Labor, Occupational Safety and Health Administration, OSHA 3138-01R.

Characteristics of a Confined Space Hazard

Many workplaces contain spaces that are considered confined because their configurations hinder the activities of employees who must enter, work in, and exit them. A confined space has limited or restricted means for entry or exit, and it is not designed for continuous employee occupancy. Confined spaces include, but are not limited to underground vaults, tanks, storage bins, manholes, pits, silos, process vessels, and pipelines. OSHA uses the term permit-required confined space to describe a confined space that has one or more of the following characteristics: contains or has the potential to contain a hazardous atmosphere; contains a material that has the potential to engulf an entrant; has walls that converge inward or floors that slope downward and taper into a smaller area which could trap or asphyxiate an entrant; or contains any other recognized safety or health hazard, such as unguarded machinery, exposed live wires, or heat stress.

Potential Construction-Related Confined Space Procedures

The employer's written program should establish the means, procedures and practices to eliminate or control hazards necessary for safe confined space entry operations. These may include the following:

- Specifying acceptable entry conditions
- Isolating the permit space
- Providing barriers
- Verifying acceptable entry conditions
- Purging, making inert, flushing, or ventilating the permit space

In addition to PPE, other equipment that employees may require for safe entry into a permit space includes the following:

- Testing, monitoring, ventilating, communications and lighting equipment
- Barriers and shields
- Ladders
- Retrieval devices

Confined Space Entry Procedures

If hazardous conditions are detected during entry, employees must immediately leave the space. The employer must evaluate the space to determine the cause of the hazardous atmosphere and modify the program as necessary.

When entry to permit spaces is prohibited, the employer must take effective measures to prevent unauthorized entry. Non-permit confined spaces must be evaluated when changes occur in their use or configuration and, where appropriate, must be reclassified as permit spaces.

A space with no potential to have atmospheric hazards may be classified as a non-permit confined space only when all hazards are eliminated in accordance with the standard. If entry is required to eliminate hazards and obtain data, the employer must follow specific procedures in the standard.

f. Describe the Hazardous Waste Operations and Emergency Response Regulations (HAZWOPER) activities at a waste site.

The following is taken from U.S. Department of Labor, Occupational Safety and Health Administration, *The Application of HAZWOPER to Worksite Response and Cleanup Activities*.

Depending on the activities being conducted and the hazards present, response activities at worksites may be considered emergency response activities under OSHA's Hazardous Waste Operations and Emergency Response (HAZWOPER) standard, 29 CFR 1910.120 and 1926.65, "Hazardous Waste Operations and Emergency Response." In addition, cleanup sites may be considered or may become hazardous waste sites, requiring specific training and control measures, if certain criteria apply. Furthermore, if HAZWOPER conflicts or overlaps with any other OSHA standard, the provision more protective of employee safety and health must be followed.

If OSHA considers a worksite response activity a HAZWOPER emergency response, then employers with employees at the site performing emergency response must comply with HAZWOPER and all other general industry or construction industry standards. The term emergency response has a very specific meaning and application under HAZWOPER. Employers often apply this term to any activity requiring immediate attention. However, under HAZWOPER this term applies specifically to response

activities where there is an uncontrolled release of a hazardous substance, or where an uncontrolled release is likely.

g. Discuss elements of hazard communications for industrial operations involving hazard specific programs (e.g., vehicle safety, violence in the workplace, asbestos, silica, lead, beryllium, blood borne pathogens, and infectious diseases).

Vehicle Safety

The following is taken from 29 CFR 1910.1201.

Any employer who receives a package of material that is required to be marked, labeled, or placarded according to U.S. Department of Transportation's hazardous materials regulations shall retain those markings, labels, and placards on the package until the packaging is sufficiently cleaned of residue and purged of vapors to remove any potential hazards.

Any employer who receives a freight container, rail freight car, motor vehicle, or transport vehicle that is required to be marked or placarded according to hazardous materials regulations shall retain those markings and placards on the freight container, rail freight car, motor vehicle or transport vehicle until the hazardous materials which require the marking or placarding are sufficiently removed to prevent any potential hazards.

Markings, placards and labels shall be maintained in a manner that ensures that they are readily visible.

For non-bulk packages that will not be reshipped, the provisions of this section are met if a label or other acceptable marking is affixed in accordance with the hazard communication standard.

Violence in the Workplace

The following is taken from the National Institute for Occupational Safety and Health, Violence in the Workplace, Developing and Implementing a Workplace Violence Prevention Program and Policy.

The first priority in developing a workplace violence prevention policy is to establish a system for documenting violent incidents in the workplace. Such data are essential for assessing the nature and magnitude of workplace violence in a given workplace and quantifying risk. These data can be used to assess the need for action to reduce or mitigate the risks for workplace violence and implement a reasonable intervention strategy. An existing intervention strategy may be identified within an industry or in similar industries, or new and unique strategies may be needed to address the risks in a given workplace or setting. Implementation of the reporting system, a workplace violence prevention policy, and specific prevention strategies should be publicized company-wide, and appropriate training sessions should be scheduled. The demonstrated commitment of management is crucial to the success of the program. The success and appropriateness of intervention strategies can be monitored and adjusted with continued data collection.

A written workplace violence policy should clearly indicate a zero tolerance of violence at work, whether the violence originates inside or outside the workplace. Just as workplaces have developed mechanisms for reporting and dealing with sexual harassment, they must also develop threat assessment teams to which threats and violent incidents can be reported. These teams should include representatives from human resources, security, employee assistance, unions, workers, management, and perhaps legal and public relations departments. The charge to this team is to assess threats of violence (e.g., to determine how specific a threat is, whether the person threatening the worker has the means for carrying out the threat, etc.) and to determine what steps are necessary to prevent the threat from being carried out. This team should also be charged with periodic reviews of violent incidents to identify ways in which similar incidents can be prevented in the future. Note that when violence or the threat of violence occurs among coworkers, firing the perpetrator may or may not be the most appropriate way to reduce the risk for additional or future violence. The employer may want to retain some control over the perpetrator and require or provide counseling or other care, if appropriate. The violence prevention policy should explicitly state the consequences of making threats or committing acts of violence in the workplace.

A comprehensive workplace violence prevention policy and program should also include procedures and responsibilities to be taken in the event of a violent incident in the workplace. This policy should explicitly state how the response team is to be assembled and who is responsible for immediate care of the victim(s), re-establishing work areas and processes, and organizing and carrying out stress debriefing sessions with victims, their coworkers, and perhaps the families of victims and coworkers. Employee assistance programs, human resource professionals, and local mental health and emergency service personnel can offer assistance in developing these strategies.

Asbestos

The following is taken from 29 CFR 1910.1001.

Communication of hazards to employees—Introduction. 29 CFR 1910.1001 applies to the communication of information concerning asbestos hazards in general industry to facilitate compliance with 29 CFR 1910.

Building and facility owners shall determine the presence, location, and quantity of asbestos containing materials (ACM) at the worksite. Employers and building and facility owners shall exercise due diligence in complying with these requirements to inform employers and employees about the presence and location of ACM.

Building and facility owners shall maintain records of all information required to be provided pursuant to 29 CFR 1910.1001 and/or otherwise known to the building owner concerning the presence, location and quantity of ACM in the building/facility. Such records shall be kept for the duration of ownership and shall be transferred to successive owners.

Building and facility owners shall inform employers of employees, and employers shall inform employees who will perform housekeeping activities in areas that contain ACM of the presence and location of ACM in such areas that may be contacted during such activities.

Warning signs shall be provided and displayed at each regulated area. In addition, warning signs shall be posted at all approaches to regulated areas so that an employee may read the signs and take necessary protective steps before entering the area.

The warning signs shall bear the following information:

DANGER
ASBESTOS
CANCER AND LUNG DISEASE HAZARD
AUTHORIZED PERSONNEL ONLY

In addition, where the use of respirators and protective clothing is required in the regulated area, the warning signs shall include the following:

RESPIRATORS AND PROTECTIVE CLOTHING
ARE REQUIRED IN THIS AREA

The employer shall ensure that employees working in and contiguous to regulated areas comprehend the warning signs. Means to ensure employee comprehension may include the use of foreign languages, pictographs and graphics.

Warning labels shall be affixed to all raw materials, mixtures, scrap, waste, debris, and other products containing asbestos fibers, or to their containers. When a building owner employer identifies previously installed ACM, labels or signs shall be affixed or posted so that employees will be notified of what materials contain ACM. The employer shall attach such labels in areas where they will clearly be noticed by employees who are likely to be exposed, such as at the entrance to mechanical room/areas. Signs may be posted in lieu of labels so long as they contain information required for labeling.

The labels shall comply with the requirements of 29 CFR 1910.1200 and shall include the following information:

DANGER
CONTAINS ASBESTOS FIBERS
AVOID CREATING DUST
CANCER AND LUNG DISEASE HAZARD

Silica

The following is taken from U.S. Department of Labor, Occupational Safety and Health Administration, Crystalline Silica Exposure.

OSHA has an established permissible exposure limit (PEL) that is the maximum amount of crystalline silica to which workers may be exposed during an 8-hour shift. OSHA also requires hazard communication training for workers exposed to crystalline silica, and requires a respirator program until engineering controls are implemented. Additionally, OSHA has a national emphasis program for crystalline silica exposure to identify, reduce, and eliminate health hazards associated with occupational exposures.

Lead

The following is taken from 29 CFR 1926.62.

The employer shall communicate information concerning lead hazards according to the requirements of OSHA's hazard communication standard for the construction industry, including but not limited to the requirements concerning warning signs and labels, material safety data sheets (MSDSs), and employee information and training. In addition, employers shall comply with the following requirements:

- The employer shall train each employee who is subject to exposure to lead at or above the action level on any day, or who is subject to exposure to lead compounds that may cause skin or eye irritation. The employer shall institute a training program and ensure employee participation in the program.
- The employer shall provide the training program as initial training prior to the time of job assignment or prior to the startup date for this requirement, whichever comes last.
- The employer shall also provide the training program at least annually for each employee who is subject to lead exposure at or above the action level on any day.

Beryllium

The following is taken from DOE G 440.1-7A.

10 CFR 850.38, "Warning Signs and Labels," requires employers to post warning signs at each access point to beryllium-regulated areas and to affix warning labels to containers of beryllium, beryllium compounds, or beryllium-contaminated items. Proper exposure control of beryllium requires that its presence be clearly identified to all who might possibly be exposed. The purpose of the warning signs and labels is to ensure that all affected individuals, not only those previously identified as potentially exposed to beryllium, are apprised of the potential hazards of beryllium exposures. The posting of signs serves as a warning to workers who may otherwise not know they are entering a regulated area where beryllium exposure may occur.

Regulated areas may often exist on a temporary basis, such as during maintenance, D&D operations, or in emergency situations. The use of warning signs under these circumstances is of particular importance because maintenance, D&D, or an emergency could present new or unexpected potential for exposure to workers who are regularly expected to conduct work unrelated to beryllium at these locations. All access points to regulated areas must be clearly identified with warning signs containing the following information:

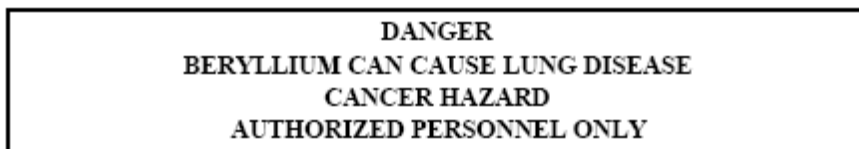

In addition to posted area signs, all containers of beryllium, beryllium compounds, beryllium parts, or beryllium-contaminated clothing, waste, scrap, or debris must have a prominent warning label. These provisions must conform to OSHA's hazard communication standard. The label must convey the following information:

DANGER
CONTAMINATED WITH BERYLLIUM
DO NOT REMOVE DUST BY BLOWING OR SHAKING
CANCER AND LUNG DISEASE HAZARD

Employers must also consider the potential for internal contamination of equipment.

In some cases, internal beryllium contamination would not pose a health hazard unless the equipment is disassembled. Additional labeling should be used to alert workers of the potential hazard. Examples of such labels include

CAUTION
BERYLLIUM CONTAMINATION
INHALATION OF DUST OR FUMES MAY CAUSE
SERIOUS CHRONIC LUNG DISEASE

This equipment was known to have been used for beryllium operations and may be internally contaminated. If the internal components of this equipment are breached, workers must be protected in accordance with applicable OSHA standards. Surveys were performed to determine the levels of external surface contamination. Survey results are packaged with the equipment.

CAUTION
POSSIBLE BERYLLIUM CONTAMINATION
INHALATION OF DUST OR FUMES MAY CAUSE
SERIOUS CHRONIC LUNG DISEASE

This equipment was in a building where beryllium manufacturing operations were performed. This equipment was not used in beryllium operations but may be internally contaminated. If the internal components of this equipment are breached, workers must be protected in accordance with applicable OSHA standards. Surveys were performed to determine the presence of external surface contamination. Survey results are packaged with the equipment.

Adequate communication and content with an emphasis on visibility and wording effectiveness is necessary to inform workers of beryllium's potential to cause serious disease. Detailed specifications for warning signs and labels, such as size, color, or other physical attributes, must conform to the requirements of 29 CFR 1910.145, "Specifications for Accident Prevention Signs and Tags." Employers are responsible for designing, producing, and using signs and labels of appropriate size, color, contrast, etc., so that they are easily visible to workers. OSHA's hazard communication standard states that employers having employees who speak other languages may add information in

their language to the material presented, as long as the information is presented in English as well.

Blood Borne Pathogens and Other Infectious Diseases

The following is taken from 29 CFR 1910.1030.

Each employer having an employee(s) with occupational exposure to blood borne pathogens shall establish a written exposure control plan designed to eliminate or minimize employee exposure.

The exposure control plan shall contain at least the following elements:

- The exposure determination
- The schedule and method of implementation for methods of compliance, communication of hazards to employees, and recordkeeping
- The procedure for the evaluation of circumstances surrounding exposure incidents

Warning labels shall be affixed to containers of regulated waste, refrigerators and freezers containing blood or other potentially infectious material; and other containers used to store, transport or ship blood or other potentially infectious materials. Similar signs should be posted outside of work areas where employees may be exposed to blood or other potentially infectious material

Labels and signs shall include the following legend:

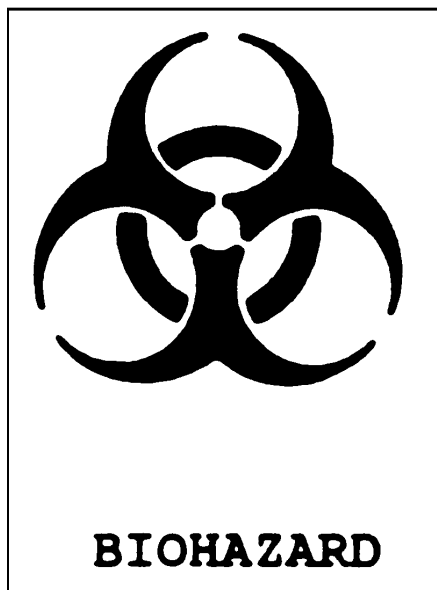

These labels shall be fluorescent orange or orange-red or predominantly so, with lettering and symbols in a contrasting color.

Labels shall be affixed as close as feasible to the container by string, wire, adhesive, or other method that prevents their loss or unintentional removal.

Mandatory Performance Activities:

h. Perform an occupational safety assessment of operations facility under the mentorship of a person qualified per the standard.

This is a performance-based KSA. The Qualifying Official will evaluate its completion.

10. Occupational safety personnel must demonstrate a working level knowledge of electricity and electrical hazards and controls to understand an electrical safety program and to coordinate it with an occupational safety program.

a. Demonstrate determination of appropriate protective equipment and operational controls.

The following is taken from 29 CFR 1910.137.

Design Requirements

Insulating blankets, matting, covers, line hose, gloves, and sleeves made of rubber shall meet the following requirements:

- Manufacture and marking
 - Blankets, gloves, and sleeves shall be produced by a seamless process.
 - Each item shall be clearly marked as follows:
 - Class 0 equipment shall be marked Class 0.
 - Class 1 equipment shall be marked Class 1.
 - Class 2 equipment shall be marked Class 2.
 - Class 3 equipment shall be marked Class 3.
 - Class 4 equipment shall be marked Class 4.
 - Non-ozone-resistant equipment other than matting shall be marked type I.
 - Ozone-resistant equipment other than matting shall be marked type II.
 - Other relevant markings, such as the manufacturer's identification and the size of the equipment, may also be provided.
 - Markings shall be non-conducting and shall be applied in such a manner as not to impair the insulating qualities of the equipment.
 - Markings on gloves shall be confined to the cuff portion of the glove.
- Electrical requirements
 - Equipment shall be capable of withstanding the a-c proof-test voltage specified in table 4 or the d-c proof-test voltage specified in table 5.
 - The proof test shall reliably indicate that the equipment can withstand the voltage involved.
 - The test voltage shall be applied continuously for 3 minutes for equipment other than matting and shall be applied continuously for 1 minute for matting.
 - Gloves shall also be capable of withstanding the a-c proof-test voltage specified in table 4 after a 16-hour water soak.
 - When the a-c proof test is used on gloves, the 60-hertz proof-test current may not exceed the values specified in table 4 at any time during the test period.
 - If the a-c proof test is made at a frequency other than 60 hertz, the permissible proof-test current shall be computed from the direct ratio of the frequencies.
 - For the test, gloves (right side out) shall be filled with tap water and immersed in water to a depth that is in accordance with table 6. Water shall be added to or removed from the glove, as necessary, so that the water level is the same inside and outside the glove.

- After the 16-hour water soak, the 60-hertz proof-test current may exceed the values given in table 4 by not more than 2 milliamperes.

Table 4. A-C proof-test requirements

Class of equipment	Maximum proof-test current MA (gloves only)				
	Proof-test voltage rms V	267-mm (10.5-in) glove	356-mm (14-in) glove	406-mm (16-in) glove	457-mm (18-in) glove
0	5,000	8	12	14	16
1	10,000	14	16	18
2	20,000	16	18	20
3	30,000	18	20	22
4	40,000	22	24

Source: 29 CFR 1910.137

Table 5. D-C proof-test requirements

Class of equipment	Proof-test voltage
0	20,000
1	40,000
2	50,000
3	60,000
4	70,000

Source: 29 CFR 1910.137

Table 6. Glove tests—water level

Class of glove	A-C proof test		D-C proof test	
	mm.	In.	mm.	In.
0	38	1.5	38	1.5
1	38	1.5	51	2.0
2	64	2.5	76	3.0
3	89	3.5	102	4.0
4	127	5.0	153	6.0

Source: 29 CFR 1910.137

Equipment that has been subjected to a minimum breakdown voltage test may not be used for electrical protection.

Material used for type II insulating equipment shall be capable of withstanding an ozone test, with no visible effects. The ozone test shall reliably indicate that the material will resist ozone exposure in actual use. Any visible sign of ozone deterioration of the

material, such as checking, cracking, breaks, or pitting, is evidence of failure to meet the requirements for ozone-resistant material.

- Workmanship and finish
 - Equipment shall be free of harmful physical irregularities that can be detected by the tests or inspections.
 - Surface irregularities that may be present on all rubber goods because of imperfections on forms or molds or because of inherent difficulties in the manufacturing process and that may appear as indentations, protuberances, or imbedded foreign material are acceptable under the following conditions:
 - The indentation or protuberance blends into a smooth slope when the material is stretched.
 - Foreign material remains in place when the insulating material is folded and stretches with the insulating material surrounding it.

In-Service Care and Use

Electrical protective equipment shall be maintained in a safe, reliable condition.

The following specific requirements apply to insulating blankets, covers, line hose, gloves, and sleeves made of rubber:

- Maximum use voltages shall conform to requirements.
- Insulating equipment shall be inspected for damage before each day's use and immediately following any incident that can reasonably be suspected of having caused damage. Insulating gloves shall be given an air test, along with the inspection.
- Insulating equipment with any of the following defects may not be used:
 - A hole, tear, puncture, or cut
 - Ozone cutting or ozone checking (the cutting action produced by ozone on rubber under mechanical stress into a series of interlacing cracks)
 - An embedded foreign object
 - Any of the following texture changes: swelling, softening, hardening, or becoming sticky or inelastic
 - Any other defect that damages the insulating properties
- Insulating equipment found to have other defects that might affect its insulating properties shall be removed from service and returned for testing.
- Insulating equipment shall be cleaned as needed to remove foreign substances.
- Insulating equipment shall be stored in such a location and in such a manner as to protect it from light, temperature extremes, excessive humidity, ozone, and other injurious substances and conditions.
- Protector gloves shall be worn over insulating gloves, except as follows:
 - Protector gloves need not be used with Class 0 gloves, under limited-use conditions, where small equipment and parts manipulation necessitate unusually high finger dexterity.
 - Any other class of glove may be used for similar work without protector gloves if the employer can demonstrate that the possibility of physical damage to the gloves is small and if the class of glove is one class higher than that required for the voltage involved. Insulating gloves that have been used without protector gloves may not be used at a higher voltage until they have been tested.

- Electrical protective equipment shall be subjected to periodic electrical tests. Test voltages and the maximum intervals between tests shall be in accordance with table 7 and table 8.

Table 7. Rubber insulating equipment voltage requirements

Class of equipment	Maximum use voltage a-c—rms	Retest voltage a- c—rms	Retest voltage d-c—avg
0	1,000	5,000	20,000
1	7,500	10,000	40,000
2	17,000	20,000	50,000
3	26,500	30,000	60,000
4	36,000	40,000	70,000

Source : 29 CFR 1910.137

Table 8. Rubber insulating equipment test intervals

Type of equipment	When to test
Rubber insulating line hose	Upon indication that insulating value is suspect
Rubber insulating covers	Upon indication that insulating value is suspect
Rubber insulating blankets	Before first issue and every 12 months thereafter
Rubber insulating gloves	Before first issue and every 6 months thereafter
Rubber insulating sleeves	Before first issue and every 12 months thereafter

Source : 29 CFR 1910.137

- The test method used shall reliably indicate whether the insulating equipment can withstand the voltages involved.
- Insulating equipment failing to pass inspections or electrical tests may not be used by employees, except as follows:
 - Rubber insulating line hose may be used in shorter lengths with the defective portion cut off.
 - Rubber insulating blankets may be repaired using a compatible patch that results in physical and electrical properties equal to those of the blanket.
 - Rubber insulating blankets may be salvaged by severing the defective area from the undamaged portion of the blanket. The resulting undamaged area may not be smaller than 22 inches by 22 inches for class 1, 2, 3, and 4 blankets.
 - Rubber insulating gloves and sleeves with minor physical defects, such as small cuts, tears, or punctures, may be repaired by the application of a compatible patch. Also, rubber insulating gloves and sleeves with minor surface blemishes may be repaired with a compatible liquid compound. The patched area shall have electrical and physical properties equal to those of the surrounding material. Repairs to gloves are permitted only in the area between the wrist and the reinforced edge of the opening.
- Repaired insulating equipment shall be retested before it may be used by employees.
- The employer shall certify that equipment has been tested. The certification shall identify the equipment that passed the test and the date it was tested.

- b. Perform a walkdown of a DOE facility with an Electrical Safety Officer to identify hazards and discuss controls and electrical installations. Explain how the DOE implements and oversees contractor electrical safety programs, including discussing the DOE directives and national standards.**

This is a performance-based KSA. The Qualifying Official will evaluate its completion.

- c. Define specific terminology applicable to the following:**

- **Measurement of electricity**
- **Power systems**
- **Electrical distribution systems**
- **Protective devices**
- **Control measures**
- **Electrical severity indices**

Measurement of Electricity

The following is taken from U.S. Energy Information Administration, Electric Conversions.

Frequently used electricity terms include the following:

- An ampere is the unit of measurement of electric current produced in a circuit by 1 volt acting through a resistance of 1 ohm.
- A Btu or British thermal unit is a standard unit for measuring the quantity of heat energy equal to the quantity of heat required to raise the temperature of 1 pound (16 ounces) of water by 1 degree Fahrenheit.
- The capacity factor of a generating unit is the ratio of the electrical energy produced by a generating unit for a given period of time to the electrical energy that could have been produced at continuous full-power operation during the same period.
- A circuit is a conductor or a system of conductors through which electric current flows.
- A current is a flow of electrons in an electrical conductor. The strength or rate of movement of the electricity is measured in amperes.
- Efficiency is derived by dividing the heat content of 1 kilowatt hour of electricity (3,412 Btu per kilowatt hour) by the number of Btu contained in the input used to produce 1 kilowatt hour.
- Energy is the capacity for doing work—as measured by the capability of doing work (potential energy) or the conversion of this capability to motion (kinetic energy). Energy has several forms, some of which can be converted into another form useful for work. Most of the world's convertible energy comes from fossil fuels that are burned to produce heat that is then used as a transfer medium to mechanical or other means in order to accomplish tasks. Electrical energy is usually measured in watt-hours, while heat energy is usually measured in Btu.
- Heat rate is a measure of generating station thermal efficiency—generally expressed in Btu per net kilowatt hour. It is computed by dividing the total Btu content of fuel burned for electricity generation by the resulting net kilowatt hour generation.
- An ohm is the unit of measurement of electrical resistance. It is the resistance of a circuit in which a potential difference of 1 volt produces a current of 1 ampere.
- A watt is the electrical unit of power, that is, the rate of energy transfer equivalent to 1 ampere flowing under a pressure of 1 volt at unit power factor.
- A watt-hour is an electric energy unit of measure equal to 1 watt of power supplied to (or taken from) an electric circuit steadily for 1 hour.

Power Systems

The following is taken from DOE-HDBK-1011/3-92.

Power Triangle

In alternating current (AC) circuits, current and voltage are normally out of phase and, as a result, not all the power produced by the generator can be used to accomplish work. By the same token, power cannot be calculated in AC circuits in the same manner as in direct current (DC) circuits. The power triangle equates AC power to DC power by showing the relationship between generator output in volt-amperes, usable power in watts, and wasted or stored power in volt-amperes-reactive (VAR).

Apparent Power

Apparent power is the power delivered to an electrical circuit. The measurement of apparent power is in voltage-amperes.

True Power

True power is the power consumed by the resistive loads in an electrical circuit. The measurement of true power is in watts.

Reactive Power

Reactive power is the power stored in an AC circuit because of the expansion and collapse of magnetic (inductive) and electrostatic (capacitive) fields. Reactive power is expressed in VAR. Unlike true power, reactive power is not useful power because it is stored in the circuit itself. This power is stored by inductors, because they expand and collapse their magnetic fields in an attempt to keep current constant, and by capacitors, because they charge and discharge in an attempt to keep voltage constant. Circuit inductance and capacitance consume and give back reactive power. Reactive power is a function of a system's amperage.

Total Power

The total power delivered by the source is the apparent power. Part of this apparent power, called true power, is dissipated by the circuit resistance in the form of heat. The rest of the apparent power is returned to the source by the circuit inductance and capacitance.

Power Factor

Power factor is the ratio between true power and apparent power. True power is the power consumed by an AC circuit, and reactive power is the power that is stored in an AC circuit.

Electrical Distribution Systems

The following is taken from DOE-HDBK-1011/4-92.

Ampacity

Ampacity is the current in amperes that a conductor can carry continuously under the conditions of use without exceeding its temperature rating.

Bond

Bond is the permanent joining of metallic parts or circuits ensuring electrical continuity and capability to safely conduct any current likely to be imposed.

Conductor

Conductor is any wire, cable, or substance capable of carrying an electrical current.

Ground

Ground is a conducting connection, whether intentional or accidental, between a circuit or piece of equipment and the earth, or some body serving as earth; a place of zero electrical potential.

Ground Voltage

Ground voltage is the voltage between any given conductor and any point at ground potential.

Leg

Leg is a current-carrying conductor intended to deliver power to or from a load normally at an electrical potential other than ground.

Neutral

Neutral is a current-carrying conductor normally tied to ground so that the electrical potential is zero.

Phase Voltage

Phase voltage is the greatest root mean square (effective) difference of potential between any two legs of the circuit.

Protective Devices

The following is taken from DOE-HDBK-1011/4-92.

Protective Relays

Protective relays are designed to cause the prompt removal of any part of a power system that might cause damage or interfere with the effective and continuous operation of the rest of the system. Protective relays are aided in this task by circuit breakers that are capable of disconnecting faulty components or subsystems. Protective relays can be used for types of protection other than short circuit or overcurrent. The relays can be designed to protect generating equipment and electrical circuits from any undesirable condition, such as undervoltage, underfrequency, or interlocking system lineups.

There are two operating principles for protective relays: 1) electromagnetic attraction and 2) electromagnetic induction. Electromagnetic attraction relays operate by a plunger being drawn up into a solenoid or an armature that is attracted to the poles of an electromagnet. This type of relay can be actuated by either DC or AC systems. Electromagnetic induction relays operate on the induction motor principle whereby torque is developed by induction in a rotor. This type of relay can be used only in AC circuits.

Overlapping Protective Zones

A separate zone of protection is provided around each system element. Any failure that may occur within a given zone will cause the tripping or opening of all circuit breakers within that zone. For failures that occur within a region where two protective zones overlap, more breakers will be tripped than are necessary to disconnect the faulty component; however, if there were no overlap of protective zones, a fault in a region between the two zones would result in no protective action at all. Therefore, it is desirable for protective zone overlap to ensure the maximum system protection.

Fuses

A fuse is a device that protects a circuit from an overcurrent condition only. It has a fusible link directly heated and destroyed by the current passing through it. A fuse contains a current-carrying element sized so that the heat generated by the flow of normal current through it does not cause it to melt the element; however, when an overcurrent or short-circuit current flows through the fuse, the fusible link will melt and open the circuit. There are several types of fuses in use.

The plug fuse is a fuse that consists of a zinc or alloy strip, a fusible element enclosed in porcelain or pyrex housing, and a screw base. This type of fuse is normally used on circuits rated at 125V or less to ground and has a maximum continuous current-carrying capacity of 30 amps. The cartridge fuse is constructed with a zinc or alloy fusible element enclosed in a cylindrical fiber tube with the element ends attached to a metallic contact piece at the ends of the tube. This type of fuse is normally used on circuits rated at either 250 or 600 Vs and has a maximum continuous current-carrying capacity of 600 amps.

Control Measures

The following are taken from Virginia Tech, Environmental, Health and Safety Services, *Confined Spaces and Definitions*.

Ground-Fault Circuit-Interrupter

A ground-fault circuit-interrupter is a device designed to disconnect an electric current when it seeks ground through a person or grounded object; thus, preventing electric shock and fires.

Isolation

Isolation is the process by which an energy source is removed from service and completely protected against the release of energy. Isolation transformers are normally low power transformers used to isolate noise from or to ground electronic circuits. Since a transformer cannot pass DC voltage from primary to secondary, any DC voltage cannot be passed, and the transformer acts to isolate this noise.

Lockout-Tagout

Lockout-tagout is the term to explain placing locks or tags on the energy isolating device (e.g., breaker boxes, control switches, valves, etc.) to prevent the unauthorized reenergization of the device or circuit while work is being performed by personnel. Tags shall indicate that the energy isolating device must not be operated until the tag is removed by the individual(s) that installed the tag.

Electrical Severity Indices

The following is taken from Energy Facility Contractors Group’s DOE Electrical Safety Improvement Project, Project Area 4–Performance Measurement, Electrical Severity Measurement Tool Revision 1.

Each electrical event is reviewed to determine its electrical severity (ES) using the following equation:

$$\text{Electrical Severity} = (\text{Electrical Hazard Factor}) (1 + \text{Environment Factor} + \text{Shock Proximity Factor} + \text{Arc Flash Proximity Factor} + \text{Thermal Proximity Factor}) (\text{Injury Factor})$$

Note that you cannot have an arc flash proximity factor and a thermal proximity factor. If the proper PPE is used while performing the work then these factors can be reduced to zero.

The ES is based on the following factors:

Table 9. Electrical severity factors

Electrical Hazard Factor	blue-no hazard	0
	green-low hazard	1
	yellow-moderate hazard	10
	orange-high hazard	50
	red-very high hazard	100

Source: Energy Facility Contractors Group’s DOE Electrical Safety Improvement Project, Project Area 4–Performance Measurement, Electrical Severity Measurement Tool Revision 1.

The electrical hazard factor is determined by classifying the source of electrical energy that the worker was exposed to during the event and then assigning a value to it, based on the electrical hazard classification charts found in the back of the referenced document as shown in table 9.

The hazard classification charts cover five broad areas, facility power, research and development, capacitors, batteries, and radio frequency. These charts, taken collectively, represent almost all of the electrical hazards found in electrical equipment. Consequently, all classes should be considered when identifying the hazards associated with any piece of electrical equipment. A single piece of equipment may have multiple electrical hazard classifications, and the worker may have been exposed to a combination of hazards. To aid hazard identification, each chart has cross-reference notes in the upper right hand corner.

The environment factor is determined by analyzing the environmental condition found in the area of the event. The environment factor is determined to assess the level of severity at the time of the event. Human skin resistance can vary considerably from a dry location to one that contains conductive fluids.

The shock proximity factor is determined by performing a shock hazard analysis using the approach boundaries in table 130.2(C) of NFPA 70E, *Standard for Electrical Safety Requirements for Employee Workplaces*. For further explanation of table 10, refer to the

NFPA 70E. The approximate distance of the worker(s) to the exposed energy source must be determined. All dimensions are distance from the exposed live part to the employee.

Table 10. Thresholds for defining shock hazards

Source	Includes	Thresholds	Hazard Classes
AC	60 Hz sub-rf 1 Hz to 3 kHz	> 50 V and >5 mA	1.2, 1.3, 1.4, 1.5 2.2b (ac), 2.2c (ac), 2.2d (ac), 2.3 (ac), 2.4 (ac)
DC	all	>100 V and > 40 mA	2.2c (dc), 2.2d (dc), 2.3 (dc), 2.4 (dc)
Capacitors	all	>100 V and > 1J	3.2b, 3.3b, 3.3c, 3.3d, 3.3e, 3.4b, 3.4c, 3.4d
Batteries	all	>100 V	Could be in any class, 4.0, 4.1, 4.2, 4.3
RF	3 kHz to 100 MHz	A function of frequency	5.2a, 5.2b

Source: Energy Facility Contractors Group’s DOE Electrical Safety Improvement Project, Project Area 4 –Performance Measurement, Electrical Severity Measurement Tool Revision 1.

The arc flash proximity factor is determined by performing a flash hazard analysis using one of the methods as described in NFPA 70E 130.3(A). The method used cannot differ from the method that the institution is using to determine PPE to protect against arc flash. The approximate distance of the worker to the energy source is used again to determine the arc flash hazard.

The thermal proximity factor is determined by performing a thermal hazard analysis by analyzing whether a conductive media came into contact with an energized source. The hazard to the worker in this case is a thermal one. The severity is determined by human contact with the conductive media and the power available to the contacting media.

The ES equation generates scores from 0 to 310,000. This range provides an exponentially rising severity that, when based on a logarithmic scale, breaks down into 4 categories of significance as shown in table 11; extreme, high, medium and low.

Table 11. Electrical severity significance

Significance	Electrical Severity	Recommended ORPS Group 2 Significance Category
Extreme	≥ 3301	1,2
High	331-3300	3*
Medium	31-330	4**
Low	1-30	***Non-Reportable

Source: Energy Facility Contractors Group’s DOE Electrical Safety Improvement Project, Project Area 4 –Performance Measurement, Electrical Severity Measurement Tool Revision 1.

- * If contact with hazardous energy is made, report under group 2 significance category 2.
- ** Currently not an option under ORPS group 2 criteria. If contact with hazardous energy is made, report under group 2 significance category 2. If no contact is made with hazardous energy, then report under group 10, significance category 4.
- ***Requires evaluation under ORPS group 10 criteria.

For example, the low (score 1-30) events are usually those items that truly did not pose a risk to the worker such as carpet shock and mishaps that were expected to happen in the work control document for which the worker was appropriately prepared for. Therefore, an event with a calculated ES value of 1-30 is not an electrical event.

The belief is that the low (score 1-30) events are low enough in severity that they should be addressed on site by the contractor having them but may not add any overall value when reported through the ORPS system.

The electrical severity index (ESI) performance metric was developed to normalize the events against organizational work hours. The ESI should be calculated monthly. The rolling twelve-month ESI average should also be calculated monthly to limit small period fluctuations. The monthly ESI and the rolling twelve-month ESI average should be tracked graphically.

The ESI is calculated when each event is weighted for severity and then averaged with other events to obtain a result representing performance.

The ES is used as the weighting factor for each event in the ESI metric that follows.

$$ESI = \frac{200,000[(ES_{event1}) + (ES_{event2}) + (ES_{eventN}) \dots]}{\text{(hours worked)}}$$

where

ESI=electrical severity index

200,000=constant (man hours for a 100 person workforce)

Event=electrical safety event

Hours worked=actual work hours for work population

d. Describe industrial electrical risk, hazards, and controls (e.g., arc flash, human response to electricity, temporary wiring, grounding, and exposed electrical wires, equipment, or parts).

Human Response to Electricity

The following is taken from the U.S. Department of Labor, Occupational Safety and Health Administration, Controlling Electrical Hazards.

Electricity flows more easily through some materials than others. Some substances such as metals generally offer very little resistance to the flow of electric current and are called conductors. A common but perhaps overlooked conductor is the surface or subsurface of the earth. Glass, plastic, porcelain, clay, pottery, dry wood, and similar substances generally slow or stop the flow of electricity. They are called insulators. Even air, normally an insulator, can become a conductor, as occurs during an arc or lightning stroke.

Electricity travels in closed circuits, normally through a conductor. But sometimes a person's body mistakenly becomes part of the electric circuit. This can cause an electrical shock. Shocks occur when a person's body completes the current path with

- both wires of an electric circuit;
- one wire of an energized circuit and the ground;

- a metal part that accidentally becomes energized due, for example, to a break in its insulation; and
- another conductor that is carrying a current.

When a person receives a shock, electricity flows between parts of the body or through the body to a ground or the earth.

An electric shock can result in anything from a slight tingling sensation to immediate cardiac arrest. The severity depends on the following:

- The amount of current flowing through the body
- The current's path through the body
- The length of time the body remains in the circuit
- The current's frequency

Table 12 shows the general relationship between the amount of current received and the reaction when current flows from the hand to the foot for just 1 second.

Table 12. Effects of electric current in the human body

Current	Reaction
Below 1 milliampere	Generally not perceptible
1 milliampere	Faint tingle
5 milliamperes	Slight shock felt; not painful but disturbing. Average individual can let go of circuit. Strong involuntary reactions can lead to other injuries.
6-25 milliamperes (women)	Painful shock, loss of muscular control.
9-39 milliamperes (men)	The freezing current or let-go range. Individual cannot let go, but can be thrown away from the circuit if extensor muscles are stimulated.
50-150 milliamperes	Extreme pain, respiratory arrest, severe muscular contractions. Death is possible
1,000-4,300 milliamperes	Rhythmic pumping action of the heart ceases. Muscular contraction and nerve damage occur; death likely.
10,000 milliamperes	Cardiac arrest, severe burns, death probable.

Source: U.S. Department of Labor, Occupational Safety and Health Administration, Controlling Electrical Hazards

Temporary Wiring

The following is taken from the Lawrence Livermore National Laboratory, ES&H Manual, volume II: Health & Safety, Controls and Hazards, document 16.1: Electrical Safety.

Construction Power and Lighting. Temporary wiring for electric power and lighting is permitted during periods of construction, remodeling, maintenance, repair, or demolition of equipment or structures and during emergencies. Temporary wiring does not mean a “reduced” level of safety or quality, as this wiring must still conform to certain criteria for electrical work.

Temporary wiring shall have a temporary wiring tag attached to it with the following information:

- Review/approval and signature of the facility manager, area supervisor, lead experimenter, construction inspector, or plant engineering electrician shop

supervisor and the signature of the appropriate ES&H team industrial safety representative

- The reason for the temporary wiring
- Installation date
- Name, phone number, and pager number (if applicable) of the person installing the temporary wiring tag

In addition, temporary wiring

- shall be approved or identified as suitable for installation and installed in accordance with the rules prescribed in the current edition of the National Electrical Code (NEC) and 29 CFR 1910 and 1926
- shall be protected from accidental damage
- shall be removed as soon as the prescribed activity is completed
- shall not be used as a substitute for permanent wiring
- shall be color coded in accordance with plant engineering or electronic engineering standards
- may be used during an off-shift working hour emergency

On the day of installation, a temporary wiring tag shall be completed and attached to the wiring so that it is readily visible. Approvals for the wiring tag must be obtained on the first regular workday after the emergency.

Switches or other means shall be installed to permit the disconnection of all ungrounded conductors of each temporary circuit. All lamps used for temporary illumination shall have a suitable fixture or lampholder with a guard to prevent damage or accidental contact with energized parts.

Experiments. Temporary wiring may be used for experimental and developmental equipment. There is no time limit on how long the wiring can remain in place, except that it must be removed upon completion of the experiment. Temporary wiring tags are not required for temporary wiring within experimental systems. However, they are required for the power feeder to the power distribution points of experimental systems. The wiring tag on these systems shall contain the same information as previously described.

Grounding

The following is taken from DOE-HDBK-1092-2004.

Circuit and system grounding consists of connecting the grounded conductor, the equipment grounding conductor, the grounding bus bars, and all noncurrent-carrying metal parts to ground. This is accomplished by connecting a properly sized unspliced grounding electrode conductor between the grounding bus bar and the grounding electrode system. There are three fundamental purposes for grounding an electrical system:

- To limit excessive voltage from lightning, line surges, and crossovers with higher voltage lines.
- To keep conductor enclosures and noncurrent-carrying metal enclosures and equipment at zero potential to ground.
- To facilitate the opening of overcurrent protection devices in case of insulation failures because of faults, short circuits, etc.

Equipment grounding systems, which consist of interconnected networks of equipment grounding conductors, are used to perform the following functions:

- Limit the hazard to personnel from the noncurrent-carrying metal parts of equipment raceways and other conductor enclosures in case of ground faults.
- Safely conduct ground-fault current at sufficient magnitude for fast operation of the circuit overcurrent protection devices.

To ensure the performance of the above functions, equipment grounding conductors are required to

- be permanent and continuous
- have ample capacity to safely conduct ground-fault current likely to be imposed on them
- have impedance sufficiently low to limit the voltage to ground to a safe magnitude and to facilitate the operation of the circuit overcurrent protection devices

Exposed Electrical Wires

The following is taken from the Office of Compliance, Safety and Health Fast Facts, Exposed Energized Wiring and Electrical Components.

Energized wire can be incredibly hazardous, as it may lead to electrocutions or fire if left unprotected. Exposed energized wiring and electrical components have become reoccurring hazards on every Office of Compliance, Capitol Hill inspection.

The OSHA and the NEC NFPA 70, *National Electric Code*, require that electrical wiring be kept free from all recognizable hazards, and that energized wiring be covered to prevent contact with other conducting materials. The NFPA also requires that live parts of electric equipment operating at 50 volts or more be guarded against accidental contact by approved enclosures, locations, and partitions. Warning signs that forbid unqualified persons from entering hazardous areas are also acceptable outside switch gear or transformer rooms.

The most common type of exposed wiring is open junction boxes, as seen in figures 3 and 4. When junction boxes are left uncovered—typically after maintenance or installation—employees can easily bump into or touch the energized wires and become vulnerable to electric shock. In addition, if combustibles such as paper are stored near energized wiring, a spark or electric current could easily start a fire.



Source: Office of Compliance, Safety and Health Fast Facts, Exposed Energized Wiring and Electrical Components

Figure 3. Electrical junction box without a cover



Source: Office of Compliance, Safety and Health Fast Facts, Exposed Energized Wiring and Electrical Components

Figure 4. Electrical wiring exposed in high traffic area

Other exposed wiring hazards include electrical outlets and switches that have either missing or broken covers, as seen in figures 5 and 6. This hazard creates a risk of electrocution for any employee plugging in an appliance or turning on a light switch. Figure 5 especially demonstrates this hazard, as a person could easily be electrocuted while reaching around this corner to turn on the switch.



Source: Office of Compliance, Safety and Health Fast Facts, Exposed Energized Wiring and Electrical Components

Figure 5. Electrical outlet without a cover



Source: Office of Compliance, Safety and Health Fast Facts, Exposed Energized Wiring and Electrical Components

Figure 6. Electrical outlet with a broken cover

Equipment or Parts

The following is taken from the Lawrence Livermore National Laboratory, ES&H Manual, volume II: Health & Safety, Controls and Hazards, document 16.1: Electrical Safety.

All electrical equipment, components, and conductors should be listed, labeled, and approved by a nationally recognized test laboratory (NRTL) for their intended purpose. Custom-made and installed equipment can be approved for use, by the electrical authority having jurisdiction (AHJ), if built according to specific standards. Appropriate documentation for such equipment shall be maintained on file.

When building, repairing, or modifying electrical systems, NRTL-approved equipment must be used if available. Non-NRTL-approved equipment shall be built in accordance with an approved design, as specified in document 16.3 of the ES&H Manual.

Document 17.1, Explosives, in the ES&H Manual provides specific guidance for explosives work and for work in explosives areas. Ensure an explosives safety engineer has reviewed the process prior to starting work in explosives facilities or areas.

Any live electrical parts shall be positively de-energized when working on or near electrical circuits, equipment, or systems. Circuits and equipment must be considered energized until isolated, locked out and tagged, and verified with an appropriate testing device as described in document 12.6, Lawrence Livermore National Laboratory, Lockout/Tagout Program, in the ES&H Manual. Where it is possible for the circuits to be energized by another source, or where capacitive and/or inductive devices may retain or build up a charge, circuits shall be grounded and shorted.

Additionally, the following precautions shall be observed to improve safety in the workplace:

- Identify and report to your supervisor potential electrical hazards or unexpected occurrences or incidents, including near misses.
 - Anticipate potential electrical problems and hazards.
 - Do not rush to finish a job; never bypass approved procedures.
 - Plan and analyze for safety during each step of any electrical work.
 - Keep accurate records for electrical or electronic systems.
 - Have significant safety-related work independently verified.
 - Use properly rated test equipment and verify its condition and operation before and after use.
 - Know applicable emergency procedures.
- e. Describe major safety concerns and appropriate control measures for working on or near live electrical equipment (e.g., proper use of lockout/tagout procedures, NFPA 70E, 29 CFR 1910.147, 10 CFR 851, DOE Electrical Safety Handbook).**

The following is taken from DOE-HDBK-1092-2004.

Working space around electrical enclosures or equipment shall be adequate for conducting all anticipated maintenance and operations safely, including sufficient space to ensure safety of personnel working during emergency conditions and workers rescuing injured personnel.

Spacing shall provide the dimensional clearance for personnel access to equipment likely to require examination, adjustment, servicing, or maintenance while energized. Such equipment includes panel boards, switches, circuit breakers, switchgear, controllers, and controls on heating and air conditioning equipment.

These clearances shall be in accordance with the National Electrical Safety Code and the NEC. These working clearances are not required if the equipment is not likely to require examination, adjustment, servicing, or maintenance while energized. However, sufficient access and working space is still required.

The NEC 110.26 states that a minimum working space 30 inches wide shall be provided in front of electrical equipment rated at 600 V or less. This provides room to avoid body contact with grounded parts while working with energized components of the equipment. The 30-in.-wide space may be centered in front of the equipment or can be offset. The depth of the working space shall be clear to the floor. Where rear access is required to work on deenergized parts, a minimum of 30 inches shall be provided. There shall be clearance in the work area to allow at least a 90-degree opening of equipment doors or hinged panels on the service equipment.

Working spaces may overlap. The depth of the working space shall be 3 ft, 3 1/2 ft, or 4 ft, depending on existing conditions. The conditions are as follows:

- Condition 1: These are exposed live components on one side of a space and ungrounded parts on the other side.
- Condition 2: The electrical equipment is mounted or set on one wall, and the wall on the opposite side is grounded. If the qualified worker should accidentally contact the conductive wall while touching live components, a circuit would be completed to ground and a fatal shock might occur.
- Condition 3: The electrical equipment is mounted or set on one wall, and additional electrical equipment is mounted or set on the opposite side of the room. There are live components on both sides of the room. The qualified worker might accidentally make contact with live components and be in series with a hot phase and the grounded metal of the electrical equipment, which could produce a fatal shock.

NEC 110.34 lists minimum clearances required for working spaces in front of high-voltage electrical equipment such as switchboards, control panels, switches, circuit breakers, switchgear, and motor controllers. There are three conditions that apply:

- Where there are exposed live components on one side of a space and no live or ungrounded parts on the other side
- Where there are exposed live components on one side and grounded parts on the other such as concrete, brick, and tile walls that are considered to be grounded parts
- Where there are exposed live components on both sides

The following is taken from 29 CFR 1910.147.

The employer shall establish a program consisting of energy control procedures, employee training and periodic inspections to ensure that before any employee performs any servicing or maintenance on a machine or equipment where the unexpected

energizing, start up or release of stored energy could occur and cause injury, the machine or equipment shall be isolated from the energy source, and rendered inoperative.

If an energy isolating device is not capable of being locked out, the employer's energy control program shall use a tagout system.

If an energy isolating device is capable of being locked out, the employer's energy control program shall use lockout, unless the employer can demonstrate that the use of a tagout system will provide full employee protection.

Whenever replacement or major repair, renovation or modification of a machine or equipment is performed, and whenever new machines or equipment are installed, energy isolating devices for such machine or equipment shall be designed to accept a lockout device.

When a tagout device is used on an energy isolating device that is capable of being locked out, the tagout device shall be attached at the same location that the lockout device would have been attached, and the employer shall demonstrate that the tagout program will provide a level of safety equivalent to that obtained by using a lockout program.

In demonstrating that a level of safety is achieved in the tagout program that is equivalent to the level of safety obtained by using a lockout program, the employer shall demonstrate full compliance with all tagout-related provisions of this standard together with such additional elements as are necessary to provide the equivalent safety available from the use of a lockout device. Additional means to be considered as part of the demonstration of full employee protection shall include the implementation of additional safety measures such as the removal of an isolating circuit element, blocking of a controlling switch, opening of an extra disconnecting device, or the removal of a valve handle to reduce the likelihood of inadvertent energization.

f. Describe the use, function, and appropriate application of PPE designed to protect workers from identified electrical hazards.

The following is taken from DOE-HDBK-1092-2004.

Employees shall wear appropriate PPE and protective clothing to protect them from hazards of high-voltage apparatus. Employees authorized or required to work on high-voltage systems shall be completely familiar with the PPE and protective clothing they need for adequate protection while working on such systems.

Refer to tables 13-17 for suggested types of PPE and protective clothing.

Table 13. Job/Safety Equipment Matrix—Use those applicable to the actual job being performed—50-V to 150-V line to ground to 250-V line to line AC or DC

Safety Equipment	Other insulated protective equipment such as gloves, blankets, sleeves, and mats.	X	X	X	X
	Safety Glasses	X	X	X	X
Tools	Insulated Hand Tools			X	X
	Insulated Fuse Puller		X		
Test Equipment	Other Approved Instrumentation	X			
	Clamp Ammeter	X			
	Approved Multimeter	X			
	Work Description				
	Voltage, Current Reading				
	Fuse Pulling under 20 amps				
	Lead Lifting under 20 amps				
	Probing				

Source: DOE-HDBK-1092-2004

Table 14. Job/Safety Equipment Matrix—Use those applicable to the actual job being performed—151-V line to ground to 600-V line to line AC or DC

Safety Requirements, Protective Equipment	Other insulated protective equipment such as fire resistant clothing, gloves, blankets, sleeves, and mats.	X	X	X	X	X	X
	Safety Belt and Life Line						X
	Face Shield						X
	Safety Glasses	X	X	X	X	X	X
Tools	Insulated Hand Tools	X			X		X
	Breaker Jacking Tools					X	
	Insulated Fuse Puller			X			
Test Equipment	Other Approved Instrumentation		X				X
	Clamp Ammeter		X				
	Approved Multimeter		X				X
	Work Description						
	Probing						
	Voltage, Current Reading						
	Pulling Control Fuses or Power Fuses at No Load						
	Pulling/Inserting Plug-in Devices on Energized MCCs						
	Jacking Breakers In/Out on Energized MCCs						
	Other Work-Energized Circuits						

Source: DOE-HDBK-1092-2004

Table 15. Job/Safety Equipment Matrix—Use those applicable to the actual job being performed—601-V to 15,000-V line to line AC

Safety Requirements, Protective Equipment	Fire Resistant Clothing	X	X		X
	Rubber Mat	X		X	X
	Sleeves	X	X	X	X
	High-Voltage Gloves	X	X	X	X
	Tagout and Lockout			X	
	Face Shield				X
	Safety Glasses	X	X	X	X
Tools	Hot Stick 5-ft Minimum				X
	High-Voltage Fuse Puller				X
	Breaker Jacking Tools		X		
Test Equipment	Other Approved Instrumentation	X			
	High Potential			X	
	High-Volt Detector	X			
	Glowtester	X			
	Work Description				
	Voltage Reading				
	Jacking Breakers In/Out on Energized Equipment				
	High Potting De-energized Equipment				
	Pulling Fuses—No Load				

Source: DOE-HDBK-1092-2004

Table 16. Job/Safety Equipment Matrix – Use those applicable to the actual job being performed—electrolytic type battery work

Safety Requirements, Protective Equipment	Fire Resistant Clothing				X
	Latex Gloves	X	X	X	X
	Apron	X	X	X	X
	Tagout and Lockout		X		X
	Goggles or Goggles and Face Shield	X	X	X	X
Tools	Insulated Hand Tools		X		X
Test Equipment	Other Approved Instrumentation	X	X	X	
	Work Description				
	Voltage Reading				
	Battery Rundowns				
	Equalize				
	Torque Bolts, Lifting Leads				

Source: DOE-HDBK-1092-2004

Qualified employees shall be trained and familiar with, but not be limited to, the following:

- Safety-related work practices, including proper selection and use of PPE, that pertain to their respective job assignments
- Skills and techniques necessary to distinguish exposed live parts from other parts of electrical equipment
- Skills and techniques necessary to determine the nominal voltage of exposed live parts, clearance distances, and the corresponding voltages to which the qualified person will be exposed
- Procedures on how to perform their jobs safely and properly
- How to lockout/tagout energized electrical circuits and equipment safely

Other types of training recommended for electrical workers include the following:

- NEC
- National Electrical Safety Code
- Use of personal protective grounds
- Use of testing and measuring equipment
- Work permit and work authorization procedures
- Use and care of PPE
- Proper clothing required for arc flash or arc blast protection
- First-aid and CPR refresher training (recommended at intervals not to exceed three years)

h. Identify and discuss application and function of major safety requirements and protective devices associated with electrical equipment and wiring in hazardous locations.

The following is taken from DOE-HDBK-1092-2004.

NEC definitions of and requirements for hazardous locations class I and class II are modified as follows for application to DOE explosives facilities:

- Areas containing explosive dusts or explosives which may, through handling or processing, produce dust capable of being dispersed in the atmosphere shall be regarded as class II, division 1 hazardous locations.
- Areas that contain exposed explosives but where no dust hazard exists shall be regarded as class II, division 2 hazardous locations.
- Suitable National Electrical Manufacturers Association-rated enclosures shall be provided in those locations where water/explosives mixtures may contact electrical equipment and wiring.
- Areas where explosives are processed and sublimation may occur or where flammable gases or vapor may be present in quantities sufficient to produce explosive or ignitable mixtures shall be regarded as class I, division 1 and class II, division 1 hazardous locations.
- To ensure a location is assigned to the proper hazardous location class and division, it is necessary to know the properties of the explosives involved there, including, at a minimum, sensitivity to heat and spark and thermal stability. If the properties of an explosive area are such that class II group G equipment provides inadequate surface temperature limits, special protection shall be provided or the equipment excluded from the hazardous location. This equipment shall not have a surface temperature exceeding the lowest onset of the exotherm of the explosive

as determined by the differential thermal analysis test or the differential scanning calorimetry test. When NEC class I or II equipment is not available, the substitute equipment shall be purged or sealed to prevent explosives contamination, shall be determined intrinsically safe by facility management, or shall be administratively controlled. If the equipment is purged, it shall be monitored for flow.

- Areas that contain explosives that are not defined as hazardous locations (areas containing no dust, vapor, gas hazards, or exposed explosives; for example, storage magazines), shall be evaluated and documented by facility management to ensure that electrical ignition sources are minimized or shall be regarded as NEC class II.
- Procedures shall be established by each DOE facility to control the use and modification of electrical equipment in explosives areas and ensure that uniform standards are adhered to throughout the facility.

i. Discuss selection, use, and performance of electrical tools and equipment noting their uses and limitations.

The following is taken from DOE-HDBK-1092-2004.

Portable electric tools and equipment such as cords, plugs, and ground fault circuit interrupters (GFCIs) should be inspected before use by both the issuer and the user for signs of chaffing, cracking, wear, or other forms of faulty insulation; evidence of a faulty grounding conductor, cracked plug, or receptacle housing; bent or missing plug or connector prongs; dead front plugs, receptacle, or connectors; a missing, bent, or otherwise abused switch; or an improperly functioning trigger lock (deadman's switch). While in use, tools and equipment should be observed for proper operation, including any signs of overheating or excessive sparking. Portable electric tools, equipment, and GFCIs should be inspected or trip-tested by the user each day before use. Signs of a defect shall require the return of the device for repair.

Portable electric tools, equipment, and GFCIs shall not be used in hazardous locations unless marked to indicate suitability for such use.

Portable electric tools and equipment shall not be handled or suspended by their cords. Tools and equipment shall be used only for their intended purpose, and when guards are required, such guards shall be in place and functional.

Tools and equipment shall be grounded via the case, double-insulated, specially approved low-voltage types, or self-contained, battery-operated.

Tools and equipment used in damp areas should be approved for such use. Generally, electrical tools are not approved for use in wet or damp areas without other means of protection.

The NEC references the use of double insulated tools in Underwriter's Laboratory (UL) Standard UL 1097, which provides the requirements for equipment marked double insulation or double insulated. Since the end-product standard takes precedence, the end-product UL standard should also be consulted when there are questions pertaining to products that require double insulation.

Double insulation is a system comprised of two insulation systems that are physically separated and are not subjected to temperature, contaminants and other deteriorating factors at the same time.

Supplementary insulation is independent of the basic insulation and provides protection against electrical shock in case of failure of the basic insulation. Also of importance is the reinforced insulation that consists of one or more layers of insulating material that, in itself, provides the same degree of protection as double insulation.

For example, two layers of insulation separating an armature lamination from an armature conductor is not double insulation. This is reinforced insulation. To achieve a double insulated system, one layer of insulation separates the armature lamination from the armature conductor (basic insulation) and an insulating sleeve provides a second layer between the armature lamination and the motor shaft (supplementary insulation).

Generally, double insulated equipment is constructed so that double insulation is provided between all live parts and the accessible surfaces of the equipment, and all inaccessible parts and surfaces that are conductively connected to the accessible surfaces of the equipment.

Under certain conditions, reinforced insulation systems are acceptable when applied to brushcaps, brushholders, commutator, and end turns of armature winding switches; power supply cords; and internal wiring.

Power supply cords for double-insulated tools shall be jacketed and shall not include a grounding conductor.

Double insulated or double insulation must be permanently marked on the tool. In addition the double insulated symbol (a square within a square) may be used.

Mandatory Performance Activities:

j. Attend professional training in NFPA 70E and then participate in an assessment of a DOE contractor's implementation of these requirements.

This is a performance-based KSA. The Qualifying Official will evaluate its completion.

11. Occupational safety personnel must demonstrate a working level knowledge of safety in construction operations, including regulatory requirements.

a. Discuss the role of safety and health during project planning and analysis.

The following is taken from 48 CFR 970.5223-1.

In performing work under this contract, the contractor shall perform work safely, in a manner that ensures adequate protection for employees, the public, and the environment, and shall be accountable for the safe performance of work. The contractor shall exercise a degree of care commensurate with the work and the associated hazards. The contractor shall ensure that management of ES&H functions and activities becomes an integral but visible part of the contractor's work planning and execution processes. The contractor shall, in the performance of work, ensure the following:

- Line management is responsible for the protection of employees, the public, and the environment. Line management includes those contractor and subcontractor employees managing or supervising employees performing work.
- Clear and unambiguous lines of authority and responsibility for ensuring ES&H are established and maintained at all organizational levels.
- Personnel possess the experience, knowledge, skills, and abilities that are necessary to discharge their responsibilities.
- Resources are effectively allocated to address ES&H, programmatic, and operational considerations. Protecting employees, the public, and the environment is a priority whenever activities are planned and performed.
- Before work is performed, the associated hazards are evaluated and an agreed-upon set of ES&H standards and requirements are established which, if properly implemented, provide adequate assurance that employees, the public, and the environment are protected from adverse consequences.
- Administrative and engineering controls to prevent and mitigate hazards are tailored to the work being performed and associated hazards. Emphasis should be on designing the work and/or controls to reduce or eliminate the hazards and to prevent accidents and unplanned releases and exposures.
- The conditions and requirements to be satisfied for operations to be initiated and conducted are established and agreed-upon by DOE and the contractor. These agreed upon conditions and requirements are requirements of the contract and binding upon the contractor. The extent of documentation and level of authority for agreement shall be tailored to the complexity and hazards associated with the work and shall be established in a safety management system.

b. Describe safety program considerations at multi-employer construction sites.

The following is taken from DOE G 440.1-2.

DOE O 440.1B requires DOE to review safety and health program elements developed by the host for site maintenance and operation activities to determine suitability and cost effectiveness on site construction projects. The intent of this requirement is twofold. First, in instances where the host and construction contractors mutually expose their employees to common hazards, it is probably desirable and cost effective to mandate construction contractor adherence to site-wide OSH policies and procedures. However, there are also instances where mandated compliance by the construction contractor with host OSH requirements that go beyond applicable DOE-adopted OSH standards or are poorly suited to construction will have little, if any, positive impact on safety and health but will adversely affect project cost and schedule.

c. Demonstrate the ability to perform the following:

- **Evaluate construction operations and identify construction hazards**
- **Identify, interpret, and apply appropriate construction safety requirements**
- **Identify and implement appropriate control measures.**

This is a performance-based KSA. The Qualifying Official will evaluate its completion.

- d. Identify excavation and trenching hazards and control considerations, including the following:**
- **Factors affecting soil stability in a trench**
 - **Application of different types of shoring, sloping, and shielding systems**
 - **Excavation and trenching inspection considerations**

The following is taken from 29 CFR 1926.651 and 652.

Factors Affecting Soil Stability in a Trench

There are a number of factors that affect soil stability in a trench. Some of the more common factors include the following:

- Surface encumbrances
- Underground utility installations
- Access and egress
- Exposure to vehicular traffic
- Exposure to falling loads
- Warning system for mobile equipment
- Hazardous atmospheres
- Protection from hazards associated with water accumulation
- Stability of adjacent structures
- Protection of employees from loose rock or soil

Application of Different Types of Shoring, Sloping, and Shielding Systems

Each employee in an excavation shall be protected from cave-ins by an adequate protective system designed according to 29 CFR 1926.652, "Requirements for Protective Systems," except when excavations are made entirely in stable rock or excavations are less than five feet in depth and examination of the ground by a competent person provides no indication of a potential cave-in.

Protective systems shall have the capacity to resist without failure all loads that are intended or could reasonably be expected to be applied or transmitted to the system. The slopes and configurations of sloping and benching systems shall be selected and constructed by the employer or his designee and shall be in accordance with 29 CFR 1926.652.

Excavations shall be sloped at an angle not steeper than one and one-half horizontal to one vertical, unless the employer uses one of the other options that follow:

- Slopes specified in 29 CFR 1926.652 to form configurations that are according to the slopes shown for type C soil.
- Maximum allowable slopes, and benching systems shall be determined according to the conditions and requirements set forth in 29 CFR 1926.652, appendices A and B.
- Designs of sloping or benching systems shall be selected from and be according to tabulated data, such as tables and charts.
- Sloping and benching systems not utilizing options 1, 2, or 3 in 29 CFR 1926.652(b) shall be approved by a registered professional engineer.

Design for timber shoring in trenches shall be determined according to the conditions and requirements set forth in 29 CFR 1926, appendices A, "Soil Classification," and C, "Timber Shoring for Trenches," subpart P. Designs for aluminum hydraulic shoring shall

be according to 29 CFR 1926.652(c)(2); but, if manufacturer's tabulated data cannot be utilized, designs shall be according to 29 CFR 1926, appendix D, "Aluminum Hydraulic Shoring for Trenches."

Shield systems shall not be subjected to loads exceeding those which the system was designed to withstand. Shields shall be installed in a manner to restrict lateral or other hazardous movement of the shield in the event of the application of sudden lateral loads. Employees shall be protected from the hazard of cave-ins when entering or exiting the areas protected by shields. Employees shall not be allowed in shields when shields are being installed, removed, or moved vertically.

Excavations of earth material to a level not greater than two feet below the bottom of a shield shall be permitted, but only if the shield is designed to resist the forces calculated for the full depth of the trench, and there are no indications while the trench is open of a possible loss of soil from behind or below the bottom of the shield.

Excavation and Trenching Inspection Considerations

Daily inspections of excavations, the adjacent areas, and protective systems shall be made by a competent person for evidence of a situation that could result in possible cave-ins, indications of failure of protective systems, hazardous atmospheres, or other hazardous conditions. An inspection shall be conducted by the competent person prior to the start of work and as needed throughout the shift. Inspections shall also be made after every rainstorm or other hazard increasing occurrence. These inspections are only required when employee exposure can be reasonably anticipated.

- e. Discuss the following hazard control considerations associated with demolition operations:**
- **Project planning and activity hazard analyses**
 - **Structural support considerations**
 - **Hazards associated with debris and appropriate removal techniques**
 - **Hazards associated with remaining energy sources, equipment, and materials (hazardous chemical /wastes)**
 - **Applicability of DOE-STD-1120-2005, Integration of Environment, Safety, and Health into Facility Disposition Activities**

Project Planning and Activity Hazard Analyses

The following is taken from OSHA, Demolition.

Before the start of every demolition job, the demolition contractor should take a number of steps to safeguard the health and safety of workers at the jobsite. Preparatory operations involve the overall planning of the demolition job, including the methods to be used to bring the structure down, the equipment necessary to do the job, and the measures to be taken to perform the work safely. Planning for a demolition job is as important as actually doing the work. Therefore, all planning work should be performed by a competent person experienced in all phases of the demolition work to be performed.

The following is taken from DOE-HDBK-1163-2003.

A third group of hazard analysis activities can be characterized as focusing on worker-related hazards associated with specific activity tasks. Each of the hazard analysis requirements reflected in this group is an integral part of work planning, which feeds into

the preparation of hazardous and radiation work permits, HASPs, IH plans and overall work packages and documentation. These activities have a different emphasis than facility-level hazard analysis, since they are primarily focused on worker protection. As such, activity-level hazard analysis addresses the hazards associated with individual job functions and tasks.

In spite of these differences, there is an important link between facility and activity level hazard analysis requirements in terms of the flow of hazards information and data. For example, facility level information and assumptions related to hazardous material inventory feed into activity hazards analysis in order to help identify the range of potential hazards a worker may encounter while carrying out his/her duties. Conversely, assessment of work-related hazards from activity-level analysis may yield insights into hazards that have not been adequately covered within facility-level analysis and as such may warrant further evaluation by a PrHA or documented safety analysis (DSA).

Structural Support Considerations

The following is taken from 29 CFR 1926.850.

Prior to permitting employees to start demolition operations, an engineering survey shall be made, by a competent person, of the structures to determine the condition of the framing, floors and walls, and possibility of unplanned collapse of any portion of the structure. Any adjacent structure where employees may be exposed shall also be similarly checked.

When employees are required to work within a structure to be demolished that has been damaged by fire, flood, explosion, or other cause, the walls or floor shall be shored or braced.

Hazards Associates with Debris and Appropriate Removal Techniques

The following is taken from 29 CFR 1926.850 through 857.

Various hazards are associated with the removal of debris. General precautions related to the removal of debris include the following:

- When debris is dropped through holes in the floor without the use of chutes, the area onto which the material is dropped shall be completely enclosed with barricades not less than 42 inches high and not less than 6 feet back from the projected edge of the opening above.
- Signs warning of the hazard of falling materials shall be posted at each level. Removal shall not be permitted in this lower area until debris handling ceases above.
- Any chute opening, into which workmen dump debris, shall be protected by a substantial guardrail.
- Walls, which are to serve as retaining walls against which debris will be piled, shall not be so used unless capable of safely supporting the imposed load.
- Before demolishing any floor arch, debris and other material shall be removed from such arch and other adjacent floor area.
- Demolition of floor arches shall not be started until they, and the surrounding floor area for a distance of 20 feet, have been cleared of debris and any other unnecessary materials.

- The storage of waste material and debris on any floor shall not exceed the allowable floor loads.

Hazards Associated With Remaining Energy Sources, Equipment, and Materials (Hazardous Chemicals/Wastes)

The following is taken from 29 CFR 1926.850.

All electric, gas, water, steam, sewer, and other service lines shall be shut off, capped, or otherwise controlled, outside the building line before demolition work is started. If it is necessary to maintain any power, water, or other utilities during demolition, such lines shall be temporarily relocated, as necessary, and protected.

It shall also be determined if any type of hazardous chemicals, gases, explosives, flammable materials, or similarly dangerous substances have been used in any pipes, tanks, or other equipment on the property. When the presence of any such substances is apparent or suspected, testing and purging shall be performed and the hazard eliminated before demolition is started. Where a hazard exists from fragmentation of glass, such hazards shall be removed.

Applicability of DOE-STD-1120-2005, Integration of Environment, Safety, and Health into Facility Disposition Activities

The following is taken from DOE-STD-1120-2005.

Volume one of DOE-STD-1120-2005 applies to hazard category 2 or 3 environmental restoration activities and decommissioning projects. Volume one does not apply to facility life cycles that are subject to the safe harbor provisions of DOE-STD-3009-94, *Preparation Guide for U.S. Department of Energy Nonreactor Nuclear Facility Documented Safety Analysis* or DOE-STD-3011-2002, *Guidance for Preparation of Basis for Interim Operation (BIO) Documents* (i.e., deactivation including material stabilization campaigns such as processing of reactive liquids and any long-term surveillance and maintenance). Since volume two has a broader focus than safety basis requirements it does apply to all phases of facility disposition (i.e., facility deactivation, surveillance and maintenance, and decommissioning).

f. Describe construction related heat and cold stress hazards and identify appropriate control measures.

The following is taken from the U.S. Department of Labor, Occupational Safety and Health Administration Technical Manual, section III, chapter 4, Heat Stress.

Heat Stroke

Heat stroke occurs when the body's system of temperature regulation fails and body temperature rises to critical levels. This condition is caused by a combination of highly variable factors, and its occurrence is difficult to predict. Heat stroke is a medical emergency. The primary signs and symptoms of heat stroke are confusion; irrational behavior; loss of consciousness; convulsions; a lack of sweating (usually); hot, dry skin; and an abnormally high body temperature (e.g., a rectal temperature of 105.8°F). If body temperature is too high, it causes death. The elevated metabolic temperatures caused by a combination of work load and environmental heat load, both of which contribute to heat stroke, are also highly variable and difficult to predict.

If a worker shows signs of possible heat stroke, professional medical treatment should be obtained immediately. The worker should be placed in a shady area and the outer clothing should be removed. The worker's skin should be wetted and air movement around the worker should be increased to improve evaporative cooling until professional methods of cooling are initiated and the seriousness of the condition can be assessed. Fluids should be replaced as soon as possible. The medical outcome of an episode of heat stroke depends on the victim's physical fitness and the timing and effectiveness of first-aid treatment.

Regardless of the worker's protests, no employee suspected of being ill from heat stroke should be sent home or left unattended unless a physician has specifically approved such an order.

Heat Exhaustion

The signs and symptoms of heat exhaustion are headache, nausea, vertigo, weakness, thirst, and giddiness. Fortunately, this condition responds readily to prompt treatment. Heat exhaustion should not be dismissed lightly, however, for several reasons. One is that the fainting associated with heat exhaustion can be dangerous because the victim may be operating machinery or controlling an operation that should not be left unattended; moreover, the victim may be injured when he or she faints. Also, the signs and symptoms seen in heat exhaustion are similar to those of heat stroke, a medical emergency.

Workers suffering from heat exhaustion should be removed from the hot environment and given fluid replacement. They should also be encouraged to get adequate rest.

Heat Cramps

Heat cramps are usually caused by performing hard physical labor in a hot environment. These cramps have been attributed to an electrolyte imbalance caused by sweating. It is important to understand that cramps can be caused by both too much and too little salt. Cramps appear to be caused by the lack of water replenishment. Because sweat is a hypotonic solution, excess salt can build up in the body if the water lost through sweating is not replaced. Thirst cannot be relied on as a guide to the need for water; instead, water must be taken every 15 to 20 minutes in hot environments.

Under extreme conditions, such as working for 6 to 8 hours in heavy protective gear, a loss of sodium may occur. Recent studies have shown that drinking commercially available carbohydrate-electrolyte replacement liquids is effective in minimizing physiological disturbances during recovery.

Heat Collapse

In heat collapse, the brain does not receive enough oxygen because blood pools in the extremities. As a result, the exposed individual may lose consciousness. This reaction is similar to that of heat exhaustion and does not affect the body's heat balance. However, the onset of heat collapse is rapid and unpredictable. To prevent heat collapse, the worker should gradually become acclimatized to the hot environment.

Heat Rashes

Heat rashes are the most common problem in hot work environments. Prickly heat is manifested as red papules and usually appears in areas where the clothing is restrictive.

As sweating increases, these papules give rise to a prickling sensation. Prickly heat occurs in skin that is persistently wetted by unevaporated sweat, and heat rash papules may become infected if they are not treated. In most cases, heat rashes will disappear when the affected individual returns to a cool environment.

Heat Fatigue

A factor that predisposes an individual to heat fatigue is lack of acclimatization. The use of a program of acclimatization and training for work in hot environments is advisable. The signs and symptoms of heat fatigue include impaired performance of skilled sensorimotor, mental, or vigilance jobs. There is no treatment for heat fatigue except to remove the heat stress before a more serious heat-related condition develops.

Controls

Ventilation, air cooling, fans, shielding, and insulation are the five major types of engineering controls used to reduce heat stress in hot work environments. Heat reduction can also be achieved by using power assists and tools that reduce the physical demands placed on a worker.

However, for this approach to be successful, the metabolic effort required for the worker to use or operate these devices must be less than the effort required without them. Another method is to reduce the effort necessary to operate power assists. The worker should be allowed to take frequent rest breaks in a cooler environment.

Acclimatization

The human body can adapt to heat exposure to some extent. This physiological adaptation is called acclimatization. After a period of acclimatization, the same activity will produce fewer cardiovascular demands. The worker will sweat more efficiently, and thus will more easily be able to maintain normal body temperatures.

A properly designed and applied acclimatization program decreases the risk of heat-related illnesses. Such a program basically involves exposing employees to work in a hot environment for progressively longer periods. NIOSH states that, for workers who have had previous experience in jobs where heat levels are high enough to produce heat stress, the regimen should be 50 percent exposure on day one, 60 percent on day two, 80 percent on day three, and 100 percent on day four. For new workers who will be similarly exposed, the regimen should be 20 percent on day one, with a 20 percent increase in exposure each additional day.

Fluid Replacement

Cool water or any cool liquid should be made available to workers to encourage them to drink small amounts frequently (e.g., one cup every 20 minutes). Ample supplies of liquids should be placed close to the work area. Although some commercial replacement drinks contain salt, this is not necessary for acclimatized individuals because most people add enough salt to their summer diets.

Engineering Controls

General ventilation is used to dilute hot air with cooler air. This technique clearly works better in cooler climates than in hot ones. A permanently installed ventilation system

usually handles large areas or entire buildings. Portable or local exhaust systems may be more effective or practical in smaller areas.

Air treatment/air cooling differs from ventilation because it reduces the temperature of the air by removing heat (and sometimes humidity) from the air.

Air conditioning is a method of air cooling, but it is expensive to install and operate. An alternative to air conditioning is the use of chillers to circulate cool water through heat exchangers over which air from the ventilation system is then passed; chillers are more efficient in cooler climates or in dry climates where evaporative cooling can be used.

Local air cooling can be effective in reducing air temperature in specific areas. Two methods have been used successfully in industrial settings. One type, cool rooms, can be used to enclose a specific workplace or to offer a recovery area near hot jobs. The second type is a portable blower with built-in air chiller. The main advantage of a blower, aside from portability, is minimal set-up time.

Another way to reduce heat stress is to increase the air flow or convection using fans, etc. in the work area. Changes in air speed can help workers stay cooler by increasing both the convective heat exchange and the rate of evaporation. Because this method does not actually cool the air, any increases in air speed must impact the worker directly to be effective.

If the dry bulb temperature is higher than 95°F, the hot air passing over the skin can actually make the worker hotter. When the temperature is more than 95°F and the air is dry, evaporative cooling may be improved by air movement, although this improvement will be offset by the convective heat. When the temperature exceeds 95°F and the relative humidity is 100 percent, air movement will make the worker hotter. Increases in air speed have no effect on the body temperature of workers wearing vapor-barrier clothing.

Heat conduction methods include insulating the hot surface that generates the heat and changing the surface itself.

Simple engineering controls, such as shields, can be used to reduce radiant heat, (i.e., heat coming from hot surfaces within the worker's line of sight). Surfaces that exceed 95°F are sources of IR radiation that can add to the worker's heat load. Flat black surfaces absorb heat more than smooth, polished ones. Having cooler surfaces surrounding the worker assists in cooling because the worker's body radiates heat toward it.

With some sources of radiation, such as heating pipes, it is possible to use both insulation and surface modifications to achieve a substantial reduction in radiant heat. Instead of reducing radiation from the source, shielding can be used to interrupt the path between the source and the worker. Polished surfaces make the best barriers, although special glass or metal mesh surfaces can be used if visibility is a problem.

Shields should be located so that they do not interfere with air flow, unless they are also being used to reduce convective heating. The reflective surface of the shield should be kept clean to maintain its effectiveness.

Administrative Controls and Work Practices

Training is the key to good work practices. Unless all employees understand the reasons for using new, or changing old, work practices, the chances of such a program succeeding are greatly reduced.

NIOSH states that a good heat stress training program should include at least the following components:

- Knowledge of the hazards of heat stress
- Recognition of predisposing factors, danger signs, and symptoms
- Awareness of first-aid procedures for, and the potential health effects of, heat stroke
- Employee responsibilities in avoiding heat stress
- Dangers of using drugs, including therapeutic ones, and alcohol in hot work environments
- Use of protective clothing and equipment
- Purpose and coverage of environmental and medical surveillance programs and the advantages of worker participation in such programs

Hot jobs should be scheduled for the cooler part of the day, and routine maintenance and repair work in hot areas should be scheduled for the cooler seasons of the year.

The following is taken from U.S. Department of Labor, Occupational Safety and Health Administration, Cold Stress Equation.

When the body is unable to warm itself, serious cold-related illnesses and injuries may occur, and permanent tissue damage and death may result.

Hypothermia can occur when land temperatures are above freezing or water temperatures are below 98.6°F.

Cold-related illnesses can slowly overcome a person who has been chilled by low temperatures, brisk winds, or wet clothing.

Workers are at increased risk when

- they have predisposing health conditions such as cardiovascular disease, diabetes, and hypertension
- they take certain medication
- they are in poor physical condition, have a poor diet, or are older

Controls

Methods to protect the workers against the cold include the following:

- Recognize the environmental and workplace conditions that lead to potential cold-induced illnesses and injuries.
- Learn the signs and symptoms of cold-induced illnesses/injuries and what to do to help the worker.
- Train the workforce about cold-induced illnesses and injuries.
- Select proper clothing for cold, wet, and windy conditions. Layer clothing to adjust to changing environmental temperatures. Wear a hat and gloves, in addition to underwear that will keep water away from the skin (polypropylene).
- Take frequent short breaks in warm dry shelters to allow the body to warm up.

- Perform work during the warmest part of the day.
 - Avoid exhaustion or fatigue because energy is needed to keep muscles warm.
 - Use the buddy system (work in pairs).
 - Drink warm, sweet beverages (sugar water, sports-type drinks). Avoid drinks with caffeine (coffee, tea, or hot chocolate) or alcohol.
 - Eat warm, high-calorie foods like hot pasta dishes.
- g. Discuss hazards and identify appropriate controls associated with construction equipment and operations, including but not limited to, the following:**
- **Scaffolding and other elevated work structures or platforms**
 - **Tools, hand and power**
 - **Heavy equipment (e.g., earth moving equipment) and traffic**
 - **Placement and temporary support of walls, floors, and other structures.**

Scaffolding

The following is taken from Mason Contractor’s Association of America, Scaffolding Hazards—Avoiding Common Mistakes.

Electricity is a major hazard when using scaffolds. Electrical lines are generally elevated to keep individuals a safe distance away. The purpose of the scaffold is obviously to allow one to work at these heights that bring workers close to this hazard.

Overloading scaffolds is another major hazard. The mason industry by nature requires heavy loads on scaffolds. Too often contractors place excessive strain on scaffolds.

The most common hazard on scaffolding is the potential for falling.

To prevent this type of fall OSHA requires employees to use an appropriate access for any scaffold higher than two feet. Climbing on any part of the frame is prohibited. Appropriate access can include a ladder built into the scaffold that meets OSHA ladder specifications, or an attached ladder.

Controls

The following is taken from Scaffolding Matters, Common Regulations When Using Various Forms of Scaffolding.

A lot of the regulations covering scaffolding should be common sense. In general, regulations when using scaffolding include the following:

- Before using scaffolding, ensure that all the wheels are locked and rigid. This is to ensure that the scaffolding is kept safe and stable for climbing.
- Any person working on mobile scaffolding must get off and stay safely on the ground before the scaffolding is ever moved.
- No one should ever remain in the “fall-zone” of the scaffolding. This is the area below the scaffolding subject to falling objects from the scaffolding.
- Always wear safety or hard hats when working on or around scaffolding. Workers should maintain a center of gravity above the part of the scaffolding that they are working on.

With regard to the actual scaffolding itself, the following rules should be adhered to:

- All of the braces, bolts and pins must be present, accounted for, and in good working order.
- Keep all planks and walk boards 36 inches or 950mm below the highest point on the scaffolding. This is the minimum scaffolding regulations allow.
- Keep any steps on the side of the scaffolding in line.

Small hand tools and other work items are often part of the job being done on scaffolding. To this end there are other scaffolding regulations and safety precautions that must be followed. The following are some of these regulations:

- All employees, irrespective of seniority or duration of time spent on the scaffolding, must wear protective headgear at all times. This must be a form of approved hat (e.g. a hard hat).
- Other protective items must also be installed on the scaffolding in the event that work tools or debris should happen to fall. These include debris nets, canopies, screens and catch platforms, and toe or kick boards.
- All personnel in the construction and use of scaffolding must be properly trained. Anyone who is planning to use or erect scaffolding of any type must be properly trained by someone qualified in its use first. Erecting or using scaffolding without proper instruction from someone who has used and is familiar with its components could be putting themselves and any other workers in danger of injury or death.

Tools, Hand and Power

The following is taken from the U.S. Department of Labor, Occupational Safety and Health Administration, Hand and Power Tools, Construction Safety and Health Outreach Program.

Tools are such a common part of our lives that it is difficult to remember that they may pose hazards. All tools are manufactured with safety in mind but, tragically, a serious accident often occurs before steps are taken to search out and avoid or eliminate tool-related hazards.

In the process of removing or avoiding the hazards, workers must learn to recognize the hazards associated with the different types of tools and the safety precautions necessary to prevent those hazards.

Hand Tools

Hand tools are non-powered. They include anything from axes to wrenches. The greatest hazards posed by hand tools result from misuse and improper maintenance.

Some examples include the following:

- Using a screwdriver as a chisel may cause the tip of the screwdriver to break and fly, hitting the user or other employees.
- If a wooden handle on a tool such as a hammer or an axe is loose, splintered, or cracked, the head of the tool may fly off and strike the user or another worker.
- A wrench must not be used if its jaws are sprung, because it might slip.

- Impact tools such as chisels, wedges, or drift pins are unsafe if they have mushroomed heads. The heads might shatter on impact, sending sharp fragments flying.

The employer is responsible for the safe condition of tools and equipment used by employees but the employees have the responsibility for properly using and maintaining tools.

Employers should caution employees that saw blades, knives, or other tools be directed away from aisle areas and other employees working in proximity. Knives and scissors must be sharp. Dull tools can be more hazardous than sharp ones.

Appropriate PPE should be worn due to hazards that may be encountered while using portable power tools and hand tools.

Safety requires that floors be kept as clean and dry as possible to prevent accidental slips with or around dangerous hand tools.

Around flammable substances, sparks produced by iron and steel hand tools can be a dangerous ignition source. Where this hazard exists, spark-resistant tools made from brass, plastic, aluminum, or wood will provide for safety.

Power Tool Precautions

Power tools can be hazardous when improperly used. There are several types of power tools, based on the power source they use: electric, pneumatic, liquid fuel, hydraulic, and powder-actuated.

Employees should be trained in the use of all tools—not just power tools. They should understand the potential hazards as well as the safety precautions to prevent those hazards from occurring.

The following general precautions should be observed by power tool users:

- Never carry a tool by the cord or hose.
- Never yank the cord or the hose to disconnect it from the receptacle.
- Keep cords and hoses away from heat, oil, and sharp edges.
- Disconnect tools when not in use, before servicing, and when changing accessories such as blades, bits and cutters.
- All observers should be kept at a safe distance away from the work area.
- Secure work with clamps or a vise, freeing both hands to operate the tool.
- Avoid accidental starting. The worker should not hold a finger on the switch button while carrying a plugged-in tool.
- Tools should be maintained with care. They should be kept sharp and clean for the best performance. Follow instructions in the user's manual for lubricating and changing accessories.
- Be sure to keep good footing and maintain good balance.
- The proper apparel should be worn. Loose clothing, ties, or jewelry can become caught in moving parts.
- All portable electric tools that are damaged shall be removed from use and tagged "Do Not Use."

Guards

Hazardous moving parts of a power tool need to be safeguarded. For example, belts, gears, shafts, pulleys, sprockets, spindles, drums, fly wheels, chains, or other reciprocating, rotating, or moving parts of equipment must be guarded if such parts are exposed to contact by employees.

Guards, as necessary, should be provided to protect the operator and others from the following:

- Point of operation
- In-running nip points
- Rotating parts
- Flying chips and sparks

Safety guards must never be removed when a tool is being used. For example, portable circular saws must be equipped with guards. An upper guard must cover the entire blade of the saw. A retractable lower guard must cover the teeth of the saw, except when it makes contact with the work material. The lower guard must automatically return to the covering position when the tool is withdrawn from the work.

Safety Switches

The following hand-held powered tools must be equipped with a momentary contact on-off control switch: drills, tappers, fastener drivers, horizontal, vertical and angle grinders with wheels larger than two inches in diameter, disc and belt sanders, reciprocating saws, saber saws, and other similar tools. These tools also may be equipped with a lock-on control provided that turnoff can be accomplished by a single motion of the same finger or fingers that turn it on.

The following hand-held powered tools may be equipped with only a positive on-off control switch: platen sanders, disc sanders with discs two inches or less in diameter; grinders with wheels two inches or less in diameter; routers, planers, laminate trimmers, nibblers, shears, scroll saws and jigsaws with blade shanks one-fourth of an inch wide or less.

Other hand-held powered tools such as circular saws having a blade diameter greater than two inches, chain saws, and percussion tools without positive accessory holding means must be equipped with a constant pressure switch that will shut off the power when the pressure is released.

Electric Tools

Employees using electric tools must be aware of several dangers; the most serious is the possibility of electrocution.

Among the chief hazards of electric-powered tools are burns and slight shocks which can lead to injuries or even heart failure. Under certain conditions, even a small amount of current can result in fibrillation of the heart and eventual death. A shock also can cause the user to fall off a ladder or other elevated work surface.

To protect the user from shock, tools must either have a three-wire cord with ground and be grounded, be double insulated, or be powered by a low-voltage isolation transformer.

Three-wire cords contain two current-carrying conductors and a grounding conductor. One end of the grounding conductor connects to the tool's metal housing. The other end is grounded through a prong on the plug. Any time an adapter is used to accommodate a two-hole receptacle, the adapter wire must be attached to a known ground. The third prong should never be removed from the plug.

Double insulation is more convenient. The user and the tools are protected in two ways: by normal insulation on the wires inside, and by a housing that cannot conduct electricity to the operator in the event of a malfunction.

These general practices should be followed when using electric tools:

- Electric tools should be operated within their design limitations.
- Gloves and safety footwear are recommended during use of electric tools.
- When not in use, tools should be stored in a dry place.
- Electric tools should not be used in damp or wet locations.
- Work areas should be well lighted.

Powered Abrasive Wheel Tools

Powered abrasive grinding, cutting, polishing, and wire buffing wheels create special safety problems because they may throw off flying fragments.

Before an abrasive wheel is mounted, it should be inspected closely and sound- or ring-tested to be sure that it is free from cracks or defects. To test, wheels should be tapped gently with a light non-metallic instrument. If they sound cracked or dead, they could fly apart in operation and so must not be used. A sound and undamaged wheel will give a clear metallic tone or ring.

To prevent the wheel from cracking, the user should be sure it fits freely on the spindle. The spindle nut must be tightened enough to hold the wheel in place, without distorting the flange. Follow the manufacturer's recommendations. Care must be taken to ensure that the spindle wheel will not exceed the abrasive wheel specifications.

Due to the possibility of a wheel disintegrating during start-up, the employee should never stand directly in front of the wheel as it accelerates to full operating speed.

Portable grinding tools need to be equipped with safety guards to protect workers not only from the moving wheel surface, but also from flying fragments in case of breakage.

In addition, when using a powered grinder

- always use eye protection
- turn off the power when not in use
- never clamp a hand-held grinder in a vise

Pneumatic Tools

Pneumatic tools are powered by compressed air and include chippers, drills, hammers, and sanders.

There are several dangers encountered in the use of pneumatic tools. The main one is the danger of getting hit by one of the tool's attachments or by some kind of fastener the worker is using with the tool.

Eye protection is required and face protection is recommended for employees working with pneumatic tools.

Noise is another hazard. Working with noisy tools such as jackhammers requires proper, effective use of hearing protection.

When using pneumatic tools, employees must check to see that they are fastened securely to the hose to prevent them from becoming disconnected. A short wire or positive locking device attaching the air hose to the tool will serve as an added safeguard.

A safety clip or retainer must be installed to prevent attachments, such as chisels on a chipping hammer, from being unintentionally shot from the barrel.

Screens must be set up to protect nearby workers from being struck by flying fragments around chippers, riveting guns, staplers, or air drills.

Compressed air guns should never be pointed toward anyone. Users should never dead-end it against themselves or anyone else.

Powder-Actuated Tools

Powder-actuated tools operate like a loaded gun and should be treated with the same respect and precautions. In fact, they are so dangerous that they must be operated only by specially trained employees.

Safety precautions to remember include the following:

- These tools should not be used in an explosive or flammable atmosphere.
- Before using the tool, the worker should inspect it to determine that it is clean, that all moving parts operate freely, and that the barrel is free from obstructions.
- The tool should never be pointed at anybody.
- The tool should not be loaded unless it is to be used immediately. A loaded tool should not be left unattended, especially where it would be available to unauthorized persons.
- Hands should be kept clear of the barrel end. To prevent the tool from firing accidentally, two separate motions are required for firing: one to bring the tool into position, and another to pull the trigger. The tools must not be able to operate until they are pressed against the work surface with a force of at least five pounds greater than the total weight of the tool.

If a powder-actuated tool misfires, the employee should wait at least 30 seconds, and then try firing it again. If it still will not fire, the user should wait another 30 seconds so that the faulty cartridge is less likely to explode, then carefully remove the load. The bad cartridge should be put in water.

Suitable eye and face protection are essential when using a powder-actuated tool.

The muzzle end of the tool must have a protective shield or guard centered perpendicularly on the barrel to confine any flying fragments or particles that might otherwise create a hazard when the tool is fired. The tool must be designed so that it will not fire unless it has this kind of safety device.

All powder-actuated tools must be designed for varying powder charges so that the user can select a powder level necessary to do the work without excessive force.

If the tool develops a defect during use it should be tagged and taken out of service immediately until it is properly repaired.

Fasteners

When using powder-actuated tools to apply fasteners, there are some precautions to consider. Fasteners must not be fired into material that would let them pass through to the other side. The fastener must not be driven into materials like brick or concrete any closer than three inches to an edge or corner. In steel, the fastener must not come any closer than one-half inch from a corner or edge. Fasteners must not be driven into very hard or brittle materials which might chip or splatter, or make the fastener ricochet.

An alignment guide must be used when shooting a fastener into an existing hole. A fastener must not be driven into a spalled area caused by an unsatisfactory fastening.

Hydraulic Power Tools

The fluid used in hydraulic power tools must be an approved fire-resistant fluid and must retain its operating characteristics at the most extreme temperatures to which it will be exposed.

The manufacturer's recommended safe operating pressure for hoses, valves, pipes, filters, and other fittings must not be exceeded.

Jacks

All jacks—lever and ratchet jacks, screw jacks, and hydraulic jacks—must have a device that stops them from jacking up too high. Also, the manufacturer's load limit must be permanently marked in a prominent place on the jack and should not be exceeded.

A jack should never be used to support a lifted load. Once the load has been lifted, it must immediately be blocked up.

Use wooden blocking under the base if necessary to make the jack level and secure. If the lift surface is metal, place a one-inch-thick hardwood block or equivalent between it and the metal jack head to reduce the danger of slippage.

To set up a jack, make certain of the following:

- The base rests on a firm level surface.
- The jack is correctly centered.
- The jack head bears against a level surface.
- The lift force is applied evenly.

Proper maintenance of jacks is essential for safety. All jacks must be inspected before each use and lubricated regularly. If a jack is subjected to an abnormal load or shock, it should be thoroughly examined to make sure it has not been damaged.

Hydraulic jacks exposed to freezing temperatures must be filled with an adequate antifreeze liquid.

General Safety Precautions

Employees who use hand and power tools and who are exposed to the hazards of falling, flying, abrasive and splashing objects, or exposed to harmful dusts, fumes, mists, vapors, or gases must be provided with the particular personal equipment necessary to protect them from the hazard.

All hazards involved in the use of power tools can be prevented by following basic safety rules:

- Keep all tools in good condition with regular maintenance.
- Use the right tool for the job.
- Examine each tool for damage before use.
- Operate according to the manufacturer's instructions.
- Provide and use the proper protective equipment.

Employees and employers have a responsibility to work together to establish safe working procedures. If a hazardous situation is encountered, it should be brought to the attention of the proper individual immediately.

Heavy Equipment

The following is taken from The Center to Protect Worker's Rights, Operating Heavy Equipment.

More than 100 people each year are killed by mobile heavy equipment, including backhoes/excavators, mobile cranes, road grading and surfacing machinery, loaders, bulldozers, and tractors on construction sites. These are the main causes of death:

- Workers on foot are struck by equipment, usually when it's backing up or changing direction.
- Equipment rolls over and kills the operator while on a slope or when equipment is loaded or unloaded from a flatbed/lowboy truck.
- Operators or mechanics are run over or caught in equipment when the brakes aren't set, equipment is left in gear, wheel chocks are not used, or the equipment and controls aren't locked out.
- Workers on foot or in a trench are crushed by falling equipment loads, backhoe buckets, or other moving parts.

The employer should ensure the following:

- Allow only trained and experienced operators to operate heavy equipment.
- Be sure operators and mechanics are trained by qualified persons experienced with the model of heavy equipment being used.
- Rent or buy only heavy equipment that has rollover protective structures (ROPS) and seat belts.
- Use only flatbed/lowboy trucks and ramps that are suitable for transporting heavy equipment.
- Ensure that a copy of the operating manual is on all machinery or available to the operator.
- Identify the hazards of overhead and underground power lines and utilities and establish procedures for working around them. Before excavation begins, use the one-call system for utility cutoffs.
- Make sure the manufacturer's safety features work.

- Set a limited access zone and/or a swing radius for each piece of equipment.
- Provide training on equipment hand signals.
- Provide trained spotters or signal persons to alert operators to workers or pedestrians in the blind spots of the equipment, including workers in trenches or manholes.

Heavy-equipment operators should perform the following:

- Review operating, safety, and shutdown procedures in the operator's manual before working with a new piece of equipment.
- Check/inspect the equipment and controls every day before starting work.
- To prevent slips and falls, keep grease and fluids off the walking/working surfaces and use three points of contact when entering and exiting equipment.
- To prevent rollovers, do not travel or work parallel to steep grades or embankments or on unstable soil.
- If possible, operate heavy equipment that has a ROPS and fasten the seatbelt.
- If equipment is rolling over or out of control, do not jump if it has a ROPS and seatbelt.
- Always put the transmission in park, shut off the motor, set the brakes, and perform any other needed shutdown procedures/lockout of controls and/or attachments before working on or around the equipment.

To protect other workers or pedestrians observe the following precautions:

- Do not back up unless you are sure no one is behind you. Use mirrors, where appropriate.
- Do not depend only on backup alarms. They are not always heard on noisy construction sites.
- Use barriers to separate workers on foot, pedestrians, and vehicles from moving equipment, where possible.
- When loading or unloading materials, make sure that only essential workers are in the area and have a spotter/signal person to let you know where they are. No one should be under a suspended load.
- Never allow other workers to ride on equipment.
- Don't speed; be extra careful around other traffic, hills, obstacles, and curves.

Placement and Temporary Support of Walls, Floors, and Other Structures

The following is taken from *Construction and Equipment, Beware of Vulnerabilities During Construction*.

Construction is a rewarding occupation, but it is also inherently dangerous. Accidents arise from a variety of causes, including electrocutions, falls, equipment failure, and collapses of unbraced excavations. Unfortunately, temporary work, such as excavation, seldom receives the attention given to more permanent construction. Despite advances in soil mechanics and the existence of well-known procedures for safe temporary support, excavations frequently lack the bracing mandated by government regulations.

Loads applied to structural members during construction quite often exceed the design service loads that will act on the completed building. Negligent stockpiling of heavy materials, for example, is a common source of catastrophic structural failures. Frequently roofs fail due to the careless stockpiling of roofing materials. The sequence of operations is fundamentally critical to structural safety in many projects.

Construction sequencing is also important for preserving the stability of incomplete structures. When the building is an assembly of prefabricated structural elements, the erection procedure is an integral part of the engineering design concept. Unless procedures are clearly specified and diligently followed, there is no guarantee that the structures will be stable during all stages of its assembly. Errors in sequencing contributed to the totality of the tragic 1987 collapse of the L'Amiance Plaza housing project in Bridgeport, Connecticut.

Construction workers were killed when failure occurred in the slab-lifting assembly. At the time of collapse, the building relied on shear walls for stability, but construction of the shear walls was lagging behind the lifting operation.

During construction, some materials, particularly cast-in-place concrete, have not yet achieved their design strength. Assemblies of timber, steel, and precast concrete rely on temporary field connections that may not be as strong or secure as the final, designed connections. These factors are responsible for many construction accidents. Most failures of cast-in-place concrete projects occur during construction, before the concrete has sufficient strength to support its own weight. Premature removal of shoring or formwork and collapse of the structure providing temporary support are the most common explanations.

There are countless examples of construction stability failures, under gravity and horizontal loads, in buildings that would have been safe if the final connections, shear walls, and floor and roof diaphragms had been completed. Such failures can be dramatic, bringing down large sections of the unfinished building or even the entire assembly. Stability of an incomplete framework, whether of timber, steel, or precast concrete, relies on temporary bracing. Determining the stability requirements for an incomplete assembly with an irregular, complicated, evolving geometry is a challenging assignment for the most skillful engineer or construction superintendent. Despite the many hazards and risks inherent to the construction process, a vast majority of projects are completed without accident or injury. Awareness of the hazards and diligent management of the risks can enhance the safety and the profitability of these achievements.

h. Discuss DOE oversight activities common to construction projects and resolution of deficiencies (i.e., DOE G 440.1-2, *Construction Safety Management Guide for Use with DOE O 440.1*).

The following is taken from DOE G 440.1-2.

Coordination of Construction and Management and Operating Safety and Health Requirements

DOE O 440.1B requires DOE to review safety and health program elements developed by the host for site maintenance and operation activities to determine suitability and cost effectiveness on site construction projects. The intent of this requirement is twofold. First, in instances where the host and construction contractors mutually expose their employees to common hazards, it is probably desirable and cost effective to mandate construction contractor adherence to site-wide occupational safety and health (OSH) policies and procedures. However, there are also instances where mandated compliance by the construction contractor with host OSH program requirements that go beyond applicable DOE-adopted OSH standards or are poorly suited to construction will have

little, if any, positive impact on safety and health but will adversely affect project cost and schedule.

Construction Contractor Evaluations

The intent of DOE O 440.1B is to ensure the development and implementation at each site of a system by which the effectiveness of construction contractors' safety and health programs are systematically and objectively evaluated and to ensure that these evaluations are subsequently used in the determination of bidder responsibility on future projects. It should be noted that the system envisioned by DOE O 440.1B does not specifically call for, nor encourage, a prequalification of prospective bidders based on empirically derived indicators of past safety and health performance such as workers' compensation experience modifier rates or incidence rates derived from a contractor's OSHA 200 log.

Inspections

DOE O 440.1B clarifies the requirement of 29 CFR 1926.20, "General Safety and Health Provisions," which calls for frequent and regular inspections of the jobsites by each employer. Consistent with requirements of the Federal Acquisition Regulation, which call for the onsite presence of a superintendent during the performance of any project work activities, DOE O 440.1B calls for daily inspections of the jobsite by the construction contractor during periods of active work.

Hazard Analysis

The intent of the required hazard analyses is to compel a proactive and systematic evaluation of project hazards, timely planning of abatement strategies, and effective, relevant employee training. This may be achieved in a variety of ways. Contract provisions may call for a complete hazard evaluation process to be performed by the construction contractor, or the project specifications may provide checklists or outlines that fulfill any portion (or all) of the hazard analysis requirements for later completion and implementation by the construction contractor.

Regardless of the procedural means chosen, a means to identify project operations requiring hazard analyses must be provided prior to project commencement. This ensures a means to "tie" those operations to the project schedule, allowing for their timely completion and providing a means for the project manager to assess whether adequate preparations have been made (i.e., abatement methods chosen/designed, professional staff in place, employee training accomplished) prior to commencement of each project phase.

Hazard Abatement

Generally, it is desirable and practical to demand immediate abatement of identified hazards on a construction project because they are mostly of the construction contractor's making. However, there are instances where it may be either impossible or impractical to demand immediate abatement of a hazard or where abatement of a particular hazard may fall outside of project scope. DOE O 440.1B provides specific steps that should be taken in such instances. It is not, however, the intent of DOE O 440.1B to provide a vehicle or a requirement for priority treatment of abatement actions outside of project scope above other pending, and possibly more crucial, site abatement actions.

Mandatory Performance Activities:

- i. **Identify hazards related to new construction (e.g., steel erection, masonry work, fall protection, wood framing, and shoring) at a construction site.**

This is a performance-based KSA. The Qualifying Official will evaluate its completion.

12. Occupational safety personnel must demonstrate a working level knowledge of accident/incident investigation, analysis, and reporting as it is practiced within DOE.

- a. **Describe purpose of and DOE directives for accident/incident investigations (e.g., DOE O 225.1B, *Accident Investigations*).**

The following is taken from DOE O 225.1B

DOE O 225.1B prescribes organizational responsibilities, authorities, and requirements for conducting investigations of certain accidents occurring at DOE facilities, operations, programs, and sites.

The purpose of the accident investigation is to understand and identify the causes that contributed to the accident so those deficiencies can be addressed and corrected to prevent recurrence and promote improved environmental protection and safety and health of DOE employees, contractors, and the public. Moreover, accident investigations are used to promote the values and concepts of a learning organization. DOE O 225.1B does not supersede the authority of DOE to perform enforcement investigations relating to contractor compliance with Federal regulations enforced by DOE.

Requirements include the following:

- **Determination.** The heads of program elements must use the criteria identified in appendix A to determine whether a Federal accident investigation board (AIB) must be appointed. This determination must be made expeditiously, taking into account that timeliness is crucial to conducting an accurate investigation, preserving the accident scene and evidence, and identifying causal factors.
- **Notification of Other Agencies.** Public laws or regulations assign other agencies responsibility for investigating certain types of accidents that could occur at DOE facilities or as a result of DOE activities. In some cases, DOE may have a memorandum of understanding (MOU) with another Federal or state agency to this effect. The appointing official must determine whether applicable MOUs have been executed, ascertain investigative jurisdiction prior to the appointment of a Federal AIB, and, as appropriate, ensure that notifications are made in accordance with these agreements (or other requirements).
- **Conducting the Investigation.** A Federal accident investigation must be conducted for the more serious accidents, and a Federal AIB must be appointed by the cognizant head of the program element. Alternatively, if the head of the program element and the Office of Health, Safety, and Security (HSS) agree that it is in the best interest of the Department, HSS will serve as the appointing official and conduct the accident investigation. The head of the program element may also process a waiver from the requirement to perform an investigation.

b. Discuss and demonstrate ability to apply criteria for determining the need for a particular type of accident/incident investigation.

The following is taken from DOE O 225.1B

The following criteria must be applied to determine whether any accident resulting from DOE, contractor, or subcontractor operations requires the appointment of a Federal AIB. Accidents must be analyzed expeditiously to determine whether a Federal AIB must be appointed based on the criteria indicated below.

Human Effects

Any injury or chemical or biological exposure that results in, or is likely to result in, the fatality of an employee or member of the public. Fatal injury is defined as any injury that results in death within 30 calendar days of the accident.

Any single accident that results in the hospitalization for more than five calendar days, commencing within seven calendar days of the accident, of one or more DOE, contractor, or subcontractor employees or members of the public due to serious personal injury. Serious personal injury means any injury that 1) results in a fracture of any bone (except simple fracture of fingers, toes, or nose); 2) causes severe hemorrhages or nerve, muscle, or tendon damage; 3) involves any internal organ; or 4) involves second or third degree burns or any burns affecting more than five percent of the body surface.

Any single accident resulting in three or more DOE, contractor, or subcontractor employees having lost-workday cases.

Accidents involving Federal or contractor employees driving vehicles while on official government business, on or off government property, must be investigated by a Federal AIB if the consequences result in meeting any of the criteria.

Radiation Exposure.

A determination must be made within 72 hours of any radiation exposure to ascertain whether the accident involves a dose to

- a general employee, exceeding any of the limits in 10 CFR 835.202, “Occupational Dose Limits for General Employees,” or 10 CFR 835.206, “Limits for the Embryo/Fetus,” by a factor of two or more;
- a minor, exceeding any of the limits in 10 CFR 835.207, “Occupational Dose Limits for Minors,” by a factor of two or more;
- a member of the public, exceeding the limit in 10 CFR 835.208, “Limits for Members of the Public Entering a Controlled Area,” by a factor of two or more.

Environmental Release of Hazardous Material

An accident that resulted in the release of a hazardous material from a DOE facility, in an amount greater than five times the reportable quantities specified in 40 CFR 302, “Designation, Reportable Quantities, and Notification.”

An accident that resulted in the release of a hazardous material from a DOE facility that meets the criterion for classification as a site area or general emergency in DOE O 151.1C, *Comprehensive Emergency Management System*.

Any offsite transportation incident involving hazardous materials that would require immediate notice pursuant to 40 CFR 302.

For facilities covered by 29 CFR 1910.119, “Process Safety Management of Highly Hazardous Chemicals” an incident that resulted in, or could reasonably have resulted in, a catastrophic release of a highly hazardous chemical in the workplace.

Property Effects

Estimated loss of or damage to DOE or other property, including aircraft, equal to or greater than \$2.5 million or requiring estimated costs equal to or greater than \$2.5 million for cleaning, decontaminating, renovating, replacing, or rehabilitating property. DOE facility damage is estimated within 72 hours of the accident based on comparison with the facility replacement value in the facility information management system database maintained by the headquarters office of Administration, Office of Engineering and Construction Management.

Any accidental loss or explosion involving radioactive or hazardous material under the control of DOE, contractors, or subcontractors in such quantities and under such circumstances to constitute hazards to human health and safety or to private property.

Any unplanned nuclear criticality.

Projected production loss or unavailability of DOE property for normal intended use or any facility occupancy for a period of 30 calendar days or more.

Other Effects

Any accident or series of accidents for which a Federal investigation is deemed appropriate by the Secretary, Deputy Secretary or Under Secretary. In such circumstances, the Secretary, Deputy Secretary, or Under Secretary may direct the Chief Health, Safety and Security Officer, Office of Health, Safety and Security to conduct an accident investigation independent of the DOE/NNSA line organization.

c. Describe accident causation models, emphasizing the importance of human reliability and effective management systems.

The following is taken from DOE G 225.1-1A.

A suite of analytical techniques available to support the accident investigation process is listed in table 3 of DOE G 225.1-1A, *Implementation Guide for Use with DOE Order 225.1A, Accident Investigations*. Change analysis, barrier analysis, root cause analysis, and events and causal factors charting and analysis are all considered core analytical techniques for accident investigations. They are easy to learn and use, are efficient, and meet the needs of DOE’s accident investigation program. While many techniques could be used on most accidents, those used must be suitable for the type and complexity of the accident. For example, causation for a complex accident could not be determined through the use of only one technique, such as barrier analysis.

In general, the core analytical techniques should be used for accident investigations to ensure that all of the contributing and root causes are identified. These techniques have

been used successfully in the past for accident investigations, although other techniques can be used if they yield similar results.

For complex accidents, more rigorous techniques, such as those that employ complicated analytical trees, may be necessary to ensure that accident causation is identified. Two examples are management oversight and risk tree (MORT) and project evaluation tree (PET).

Other analytical techniques could be used, if needed, for specific situations such as scientific modeling (e.g., for incidents involving criticality and atmospheric dispersion), material and structural analysis, human factors analysis, software hazards analysis, common cause failure analysis, or sneak circuit analysis. In certain situations, an integrated accident event matrix may be developed to determine the actions and interactions of personnel around the time of the accident. The application of analytical techniques for a given accident is determined by the board chairperson, in consultation with board members and advisors/consultants who have expertise in available techniques.

Table 18. Accident investigation analytical techniques

Core Analytical Techniques
<p>For the basic accident with few system failures, these analytical techniques may be used:</p> <ul style="list-style-type: none"> Barrier Analysis Change Analysis Root Cause Analysis (manual or automated) Events and Causal Factors Charting and Analysis
Complex Analytical Techniques
<p>For complex accidents with multiple system failures, the analytical techniques may include fault or analytic tree analysis, and the core analytical techniques listed above.</p>
Specific Analytical Techniques
<p>This pool of analytical techniques should be used to select techniques for specific investigations (depending on the nature and complexity of the accident) as determined by subject matter experts and the board chairperson.</p> <ul style="list-style-type: none"> Human Factors Analysis Integrated Accident Event Matrix Failure Modes and Effects Analysis Software Hazards Analysis Common Cause Failure Analysis Sneak Circuit Analysis 72-Hour Profile Materials and Structural Analysis Scientific Modeling (e.g., for incidents involving criticality and atmospheric dispersion)

Source: DOE G 225.1-1A

d. Discuss and apply necessary techniques for gathering facts applicable to an investigation and interviewing witnesses.

The following is taken from DOE G 225.1-1A.

Human evidence can be extremely delicate. Eyewitnesses can forget, overlook, or fail to recall evidence of critical value to the investigation. Individuals naturally begin to rationalize the circumstances of traumatic accidents after the event. Therefore, to preserve accuracy, the preferred approach is to obtain and record initial eyewitness statements before the participants and witnesses leave the accident site. This step should be taken as part of the initial response efforts.

After the board arrives, a witness interviewing schedule should be established, and interviewing should begin as soon as practical. A neutral location free from distractions should be reserved for these interviews. Each board member is responsible for ensuring that the interviews are effective and productive. Court reporters should be used to document key interviews to ensure accuracy and expeditious availability of transcripts to the board. Recording should commence at the opening statement. In some cases, those being interviewed may request the presence of an attorney or union representative during the interview. Unless directed to do otherwise by DOE legal counsel, this request should be honored. The transcript should then be reviewed for accuracy by the board and the witness, and discrepancies should be resolved. The transcript should be read by all board members and placed in the investigation files.

Interviewing Techniques

Care needs to be exercised in interviewing witnesses to minimize hearsay and collaboration. It also may be necessary to conduct follow-up interviews of witnesses for clarifying and corroborating information. A board member should be present at key interviews and control the interviews. Good interviewing techniques that will aid in this effort include the following:

- Plan the interview. Determine ahead of time what information is needed and what questions need to be asked.
- Establish rapport before the interview starts. Create an environment in which the witness will be more comfortable. Do not treat the interview like an interrogation.
- Provide a standard opening statement to ensure consistency for all interviews.
- Before asking specific questions, ask the interviewee to provide a description of the events in his/her own words. Do not interrupt during this description.
- Ask open-ended questions (i.e., questions that cannot be answered by “yes” or “no” responses).
- Be unbiased and nonjudgmental. Do not ask leading questions or questions that suggest a certain point of view; the witness may believe that a decision has already been made and any contrary information will not be taken seriously.
- Schedule effectively. Schedule time between interviews to reflect on the information obtained and to decide whether any new information has affected the questions planned for the next witness.

- e. **Discuss and apply necessary analysis techniques used in accident investigations, such as management oversight and risk tree; change analysis; events and causal factor analysis; energy trace and barrier analysis; and basic logic tree analysis methods.**

Management Oversight and Risk Tree

The following is taken from the DOE Conducting Accident Investigations.

MORT is a comprehensive analytical tree technique that was originally developed for DOE to help conduct nuclear criticality and hardware analysis. It was later adapted for use in accident investigations and risk assessments. Basically, MORT is a graphical checklist, but unlike the events and causal factors chart, which must be filled in by investigators, the MORT chart contains generic questions that investigators attempt to answer using available factual data. This enables the investigator to focus on potential key causal factors. The MORT chart's size can make it difficult to learn and use effectively. For complex accidents involving multiple systems, such as nuclear systems failures, MORT can be a valuable tool but may be inappropriate for relatively simple accidents. MORT requires extensive training to effectively perform an in-depth causal analysis of complex accidents. If needed, the MORT analysis is usually performed by board members with substantial previous experience in using the MORT techniques.

In evaluating accidents, MORT provides a systematic method (analytic tree) for planning, organizing, and conducting a comprehensive accident investigation. Through MORT analysis, investigators identify deficiencies in specific control factors and in management system factors. These factors are evaluated and analyzed to identify the causal factors of the accident. Detailed knowledge and understanding of M&O systems is a prerequisite to a comprehensive MORT analysis. Therefore, it is most effective if investigators have collected substantial evidence before initiating the MORT process. The management system data required include procedures, policies, implementation plans, risk assessment program, and personnel. Information about the facility, operating systems, and equipment is also needed. This information can be obtained through reviews of physical evidence, interview transcripts, management systems, and policies and procedures.

The first step of the process is to obtain the MORT charts and select the MORT chart for the safety program area of interest evaluating each event. Next, the investigators work their way down through the tree, level by level, proceeding from known to unknown. Events should be coded in a specific color relative to the significance of the event (accident). The color-coding system used in MORT analysis is shown in table 19.

Table 19. MORT coloring coding system

Color Code	Significance
Red	The event is less than adequate. Corrective actions are needed. All events colored red must be documented and supported with facts and analyzed as potential causal factors of the accident.
Green	The event is satisfactory and adequate. Credible evidence must support this event to ensure that no corrective actions need to be identified for this event.
Blue	The event has insufficient evidence or information to evaluate. Additional facts or evidence must be collected to analyze this event.
Black	The event is not applicable or relevant to the accident. The event does not need any further investigation.

Source: DOE Conducting Accident Investigations

Change Analysis

The following is taken from DOE G 225.1-1A.

Change analysis is a systematic approach to problem-solving that can help identify accident causes. Change analysis is a simple, straightforward process that is relatively quick and easy to learn and apply.

Change is a necessary ingredient for progress; however, changes to systems and their impact also contribute to errors, loss of control, and accidents. The purpose of change analysis is to identify and examine all changes systematically and to determine the significance or impact of the changes. The use of this technique in accident investigation is particularly well-suited for finding quick answers and identifying causal factors that are not otherwise obvious.

It has been demonstrated that, when problems arise for any functional system that has been operating satisfactorily (i.e., up to some standard), changes and differences associated with personnel, plant and hardware, or procedures and managerial controls are actual causal factors in creating these problems. Change can be thought of as stress on a system that was previously in a state of dynamic equilibrium. Change can also be viewed as anything that disturbs the planned or normal functioning of a system.

Accident investigators need to carefully evaluate all the changes identified during the investigation. Did the change really cause the result, or did the change merely bring an existing system deficiency to light? The investigation must focus on the systemic deficiencies that allowed the accident to happen and not just accept the changes identified as being the sole cause of the accident. Often, change analysis will lead to further insight into areas that must be explored by other analytical techniques.

Events and Causal Factors Charting and Analysis

The following is taken from DOE G 225.1-1A.

Identifying systemic causal factors requires understanding the sequence of events over time and the interaction of those events and their causal factors. This sequence proceeds from an initiating event through the final loss-producing occurrence. A meticulous

tracing of unwanted energy transfers and their relationships to each other and to the people, plant, procedures, and controls involved in an accident will usually reveal a definable sequence for an accident.

Two basic principles are helpful in defining and understanding these sequences of events, causal factors, and energy transfers:

1. Accidents result from a set of successive events that produce unintentional harm. The accident sequence occurs during the conduct of some work activity.
2. Events and causal factors charting is an integral and important part of the DOE accident investigation process. It is used in conjunction with other key tools to achieve optimal analytical results in accident investigation.

An events and causal factors chart is a graphic representation that produces a picture of the accident: both the sequence of events that led to the accident and the conditions that were causal factors.

Events and causal factors analysis is an effective means of integrating other analytical techniques into a concise and complete investigative summary. Events and causal factors analysis depicts, in logical sequence, the necessary and sufficient events and conditions for accident occurrence. It provides a systematic accident analysis tool to aid in collecting, organizing, and depicting accident information; validating information from other analytical techniques; writing and illustrating the accident investigation report; and briefing management on the results of the investigation.

Energy Trace

The following is taken from the Federal Aviation Association, System Safety Handbook, Chapter 9: Analysis Techniques.

This hazard analysis approach addresses all sources of uncontrolled and controlled energy that have the potential to cause an accident. Sources of energy causing accidents can be associated with the product or process, the resource if different than the product/process, and the items/conditions surrounding the system or resource of concern. A large number of hazardous situations are related to uncontrolled energy associated with the product or the resource being protected (e.g., human error). Some hazards are passive in nature.

The purpose of energy trace analysis is to ensure that all hazards and their immediate causes are identified. Once the hazards and their causes are identified, they can be used as top events in a fault tree or used to verify the completeness of a fault hazard analysis. Consequently, the energy trace analysis method complements but does not replace other analyses, such as fault trees, event trees, and FMEAs.

Identification of energy sources and energy transfer processes is the key element in the energy source analysis procedure. Once sources of energy have been identified, the analyst eliminates or controls the hazard using the system safety precedence process.

These analyses point out potential unwanted conditions that could conceivably happen. Each condition is evaluated further to assess its hazard potential. The analysis and control procedures are applied to the identified hazards.

Fourteen energy trace analysis procedural steps are:

- Identify the resource being protected to guide the direction of the analysis toward the identification of only those conditions that would be critical or catastrophic from a mission viewpoint.
- Identify system and subsystems, and safety critical components.
- Identify the operational phase(s), such as preflight, taxi, takeoff, cruise, landing, that each system/subsystem/component will experience. It is often desirable to report results of hazard analyses for each separate operational phase.
- Identify the operating states for the subsystems/components during each operational phase.
- Identify the energy sources or transfer modes that are associated with each subsystem and each operating state.
- Identify the energy release mechanism for each energy source. It is possible that a normal energy release could interact adversely with other components in a manner not previously or adequately considered.
- Review a generic threat checklist for each component and energy source or transfer mode. Experience has shown that certain threats are associated with specific energy sources and components.
- Identify causal factors associated with each energy release mechanism. A hazard causal factor may have subordinate or underlying causal factors associated with it. For instance, excessive stress may be a top level factor. The excessive stress may, in turn, be caused by secondary factors such as inadequate design, material flaws, poor quality welds, excessive loads due to pressure or structural bending. By systematically evaluating such causal factors, an analyst may identify potential design or operating deficiencies that could lead to hazardous conditions. Causal factors are identified independent of the probability of occurrence of the factor; the main question to be answered is: Can the causal factor occur or exist?
- Identify the potential accident that could result from energy released by a particular release mechanism.
- Define the hazardous consequences that could result given the accident specified in the previous step.
- Evaluate the hazard category associated with the potential accident.
- Identify the specific hazard associated with the component and the energy source or transfer mode relative to the resource being protected.
- Recommend actions to control the hazardous conditions.
- Specify verification procedures to ensure that the controls have been implemented adequately.

Barrier Analysis

The following is taken from DOE G 225.1-1A.

The basic premise of barrier analysis is that there is energy flow associated with all accidents. This energy may be kinetic, potential, electromagnetic, thermal, steam, other pressurized gases or liquids, or a myriad of other types of energy. It is the isolation, shielding, and control (barriers) of this energy (hazard) from people, property, or the environment (targets) that prevents accidents. Barriers generally fall in the following categories: equipment, design, administrative (procedures and work processes), supervisory/management, warning devices, knowledge and skills, and physical. Therefore, identifying the energy sources and the failed or deficient barriers and controls

in an accident investigation provides the means for identifying the causal factors of the accident.

If barriers were installed and one failed partially or totally, an investigator would examine the secondary safety systems, if any, that were in place to mitigate the failure. The investigator would also determine what events led up to and through the failure sequence, paying particular attention to changes made in the system. To accomplish this, the entire sequence of events can be broken down into a logical flow from the beginning to the end of an accident. Questions are asked about the practicality of the barriers and controls selected, why they failed, or why none were selected for use.

The principal benefits of barrier analysis are that it identifies safety system elements that failed, and the results can be succinctly presented. Another benefit of barrier analysis is that the results can easily be presented graphically. A graphical flowchart (diagram) can clearly and concisely portray the energy flows and failed or unused barriers that led to the accident. Thus, barrier analysis is valuable in understanding the accident and the sequence of events that led to it.

Analytical Trees

The following is taken from DOE G 225.1-1A.

An analytical tree is a graphical representation of an accident using a deductive approach (general to specific). The tree starts with the event (accident) and branches out as specific details are developed. The bottom branches of the tree can be used to identify the causal factors. There are many acceptable equivalent methods of using analytical trees, such as fault trees (computerized and manual versions), of which MORT and PET are two examples.

f. Describe the purpose and content of an accident investigation report.

The following is taken from DOE G 225.1-1A.

The purpose of accident investigation reports is to clearly and concisely convey the results of the investigation in a manner that will help the reader understand what happened, why it happened, and what can be done to prevent a recurrence. Investigation results shall be reported without attributing individual fault or proposing punitive measures. The investigation report constitutes an accurate and objective record of the accident and provides complete and accurate details and explicit statements of the board's investigation process, facts pertaining to the accident, analytical results, causes of the accident, conclusions reached, and judgments of need to correct deficiencies that should have, or could have, prevented the accident.

The investigation report should consist of the following elements:

- **Appointing Official's Report Acceptance**
The appointing official should sign a statement that the investigation has been completed in accordance with procedures specified in DOE O 225.1B and that the final report has been accepted from the AIB.
- **Acronyms and Initialisms**
This is self-explanatory. If necessary, a glossary of technical terms should follow this section.

- **Prologue—Interpretation of Significance**
This is a one-page discussion of the key management concerns and the primary lessons learned from the accident.
- **Executive Summary**
The executive summary should include a brief account of the essential facts surrounding the occurrence and major consequences (what happened); the conclusions and root causes based on factors such as the organizational, management system, and line management oversight deficiencies that allowed the accident to happen (why it happened); and judgments of need for preventing recurrence of the accident (what must be done to correct the problem and prevent it from recurring). It should be written for the executive or for the general reader who may be relatively unfamiliar with the subject matter. It should not contain information not discussed elsewhere in the report.
- **Introduction**
This section normally contains three major subsections: 1) a brief description of the accident and its results, and a statement regarding the authority to conduct the investigation; 2) brief descriptive data concerning the facility, area, or site and the major organizations involved, to help the reader understand the context of the accident and the information that follows; and 3) descriptions of the scope of the investigation, its purpose, and the methodology employed in conducting the investigation.
- **Facts and Analysis**
This section states the facts related to the accident and the analysis of those facts. It focuses on events connected to the accident and the causal factors that allowed those events to occur. This section should logically lead the reader to the conclusions and judgments of need. It includes subsections dealing with: 1) accident responses to the accident; 2) facts and analysis regarding pertinent physical hazards, controls, and other related factors (a separate subsection on management systems is included); 3) brief descriptions and results of various analyses that were conducted (e.g., events and causal factors analysis, barrier analysis, change analysis, root cause analysis); and 4) causal factors, including the direct (as applicable), contributing, and root causes. Care should be taken in writing the report to clearly distinguish facts from analysis, which may contain opinions. Photos and diagrams, which may provide perspectives that written narrative cannot capture, may be included, as determined by the board.
- **Conclusions and Judgments of Need**
This section includes conclusions in the form of 1) statements of what was found (through interviews, analysis, deduction, etc.) by the AIB and 2) judgments of need, which are identified needs (actions) required to prevent future accidents.
- **Minority Report**
If required, this section contains any board member opinions that differ from the consensus of the board. It should address only those sections of the report in which there is a minority opinion, should follow the same format as the overall report (addressing only the points of variance), and should not be a complete rewrite of the report. Those sections of the report in which there is a minority opinion, should follow the same format as the overall report (addressing only the points of variance), and should not be a complete rewrite of the report.
- **Board Signatures**

The AIB chairperson and members shall sign and date the report, even if one or more have written a minority opinion. The signature page indicates the name and position of each board member and the AIB chairperson, and it indicates whether the signatory is a DOE accident investigator.

- **Board Members, Advisors, Consultants, and Staff**

This section contains the names of the board members, advisors, and staff, indicating their employers, job titles, and positions.

g. Discuss the importance of providing feedback on accident investigations, and describe the management systems necessary to ensure this feedback is communicated to DOE.

The following is taken from DOE G 225.1-1A.

Feedback information on the adequacy of controls is gathered, opportunities for improving the definition and planning of work are identified and implemented, line and independent oversight is conducted, and, if necessary, regulatory enforcement actions occur.

Lessons learned from accident investigations are developed in accordance with DOE-STD-7501-95, *Development of DOE Lessons Learned Programs*.

Lessons learned from the accident investigation are developed and disseminated within 90 calendar days of acceptance of the investigation report by the appointing official. Methods for disseminating lessons learned include hard copy, electronic, and other methods for use both intra-site and across the DOE complex, such as reports, workshops, and newsletters. The DOE lessons-learned information system provides for electronic dissemination of lessons-learned information throughout the DOE complex.

h. Describe and understand the importance of securing the accident scene, preserving evidence, and rules of conduct, including contractor cooperation.

The following is taken from DOE G 225.1-1A.

Preserving an accident scene and evidence is important to the ensuing investigation. Important evidence must be collected quickly, or it may be lost or lose its value to the investigation. Site procedures should specify the DOE or contractor official who will control the scene and access to it. Generally, an accident scene should be isolated as soon as possible until it is turned over to the AIB. This action prevents the scene from being disturbed or altered, prevents evidence from being removed from or relocated at the scene, and protects people from hazards that may remain after an accident. An accident scene can be protected in a number of ways, including: cordoning off the area with rope, tape, or barricades; locking doors and gates; posting warning signs; using a log to document who enters the area and their justification for entry; and posting guards to control and limit access. Special controls and coordination with local security operations are necessary if the accident scene or evidence contains classified or unclassified controlled nuclear information material. The AIB may require that the same or different preservation and control procedures be kept in place until it has concluded the examination and documentation of the scene.

There may be circumstances where an accident scene must be preserved for investigation by an agency other than DOE. This could include the National Transportation Safety Board, OSHA, law enforcement agencies, or other agencies that may exercise jurisdiction to conduct investigations. In the event that an accident scene must be preserved to satisfy the investigative needs of these agencies, the scene should be cordoned off, access to it controlled, and otherwise secured, as indicated above, until the agency having jurisdiction arrives and takes control of the scene.

i. Discuss event and causal factor charting for an incident.

This is a site-specific, performance-based KSA. The Qualifying Official will evaluate its completion. The following information taken from the OSHA Academy, Event and Causal Factor Charting may be helpful.

Event and Causal Factor Charting

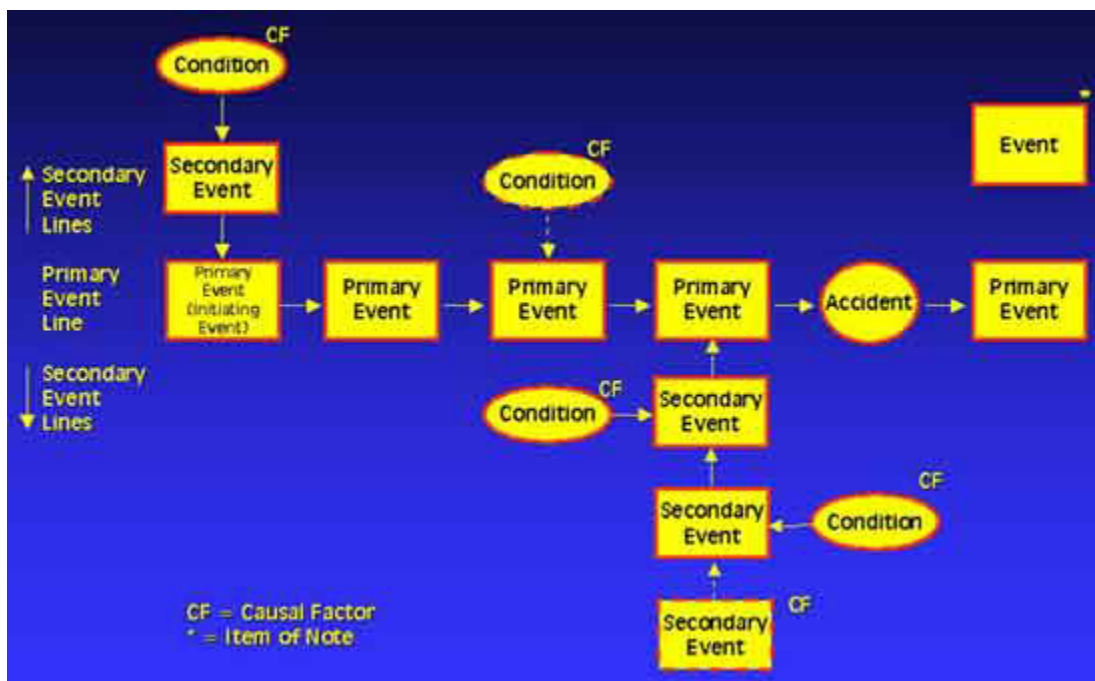

Event and causal factor charting is a written or graphical description for the time sequence of contributing events associated with an accident. The charts produced in event charting consist of the following elements:

- Condition. A distinct state that facilitates the occurrence of an event. A condition may be equipment status, weather, employee health, or anything that affects an event.
- Event. A point in time defined by a specific action occurring
- Accident. Any action, state, or condition in which a system is not meeting one or more of its design intents. Includes actual accidents and near misses. This event is the focus of the analysis.
- Primary event line. The key sequence of occurrences that led to the accident. The primary event line provides the basic nature of the event in a logical progression, but it does not provide all of the contributing causes. This line always contains the accident, but it does not necessarily end with an accident event. The primary event line can contain both events and conditions.

- Primary events and conditions. The events and conditions that make up the primary event line
- Secondary event lines. The sequences of occurrences that lead to primary events or primary conditions. The secondary event lines expand the development of the primary event line to show all of the contributing causes for an accident. Causal factors are almost always found in secondary event lines, and most event and causal factor charts have more than one secondary event line. Note that the secondary event lines can contain both events and conditions.
- Secondary events and conditions. The events and conditions that make up a secondary event line
- Causal factors. Key events or conditions that, if eliminated, would have prevented an accident or reduced its effects. Causal factors are such things as human error or equipment failure, and they commonly include the following:
 - The initiating event for an accident
 - Each failed safeguard
 - Each reasonable safeguard that was not provided
- Items of note. Undesirable events or conditions identified during an analysis that must be addressed or corrected but did not contribute to the accident of interest. These are shown as separate boxes outside the event chain.

Limitations of Event and Causal Factor Charting

Although event charting is an effective tool for understanding the sequence of contributing events that lead to an accident, it does have two primary limitations:

- Will not necessarily yield root causes. Event charting is effective for identifying causal factors. However, it does not necessarily ensure that the root causes have been identified, unless the causal factor is the root cause.
- Overkill for simple problems. Using event charting can overwork simple problems. A two-event accident probably does not require an extensive investigation of secondary events and conditions.

Procedure for Event and Causal Factor Charting

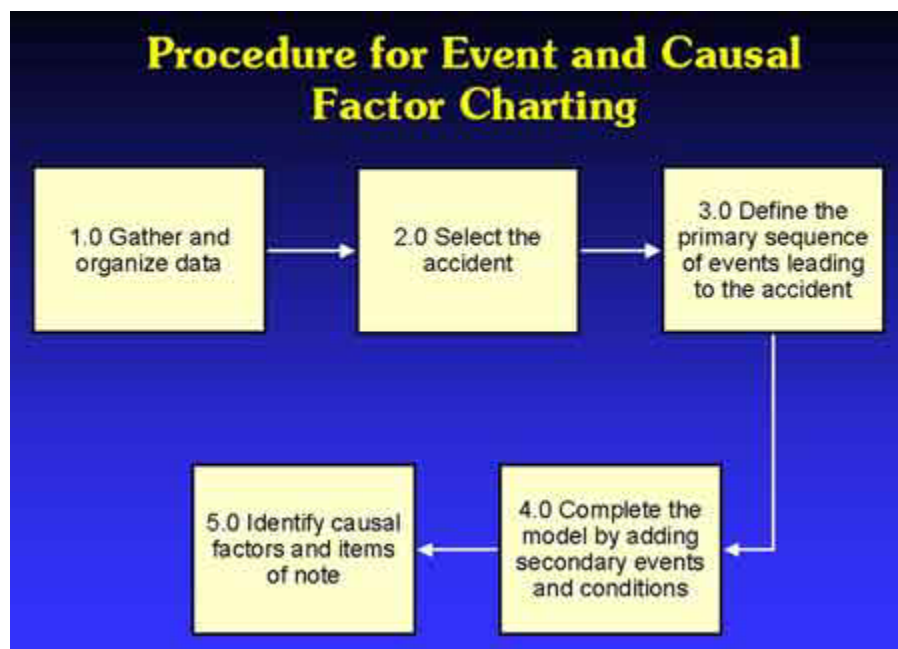

1.0 Gather and organize data. Collect known data for actors associated with the accident. An actor is a person, parameter, or object that has an action in the event chain. Organize the data into a timeline. Review data for consistency and gaps. This step is not always necessary for simple events.

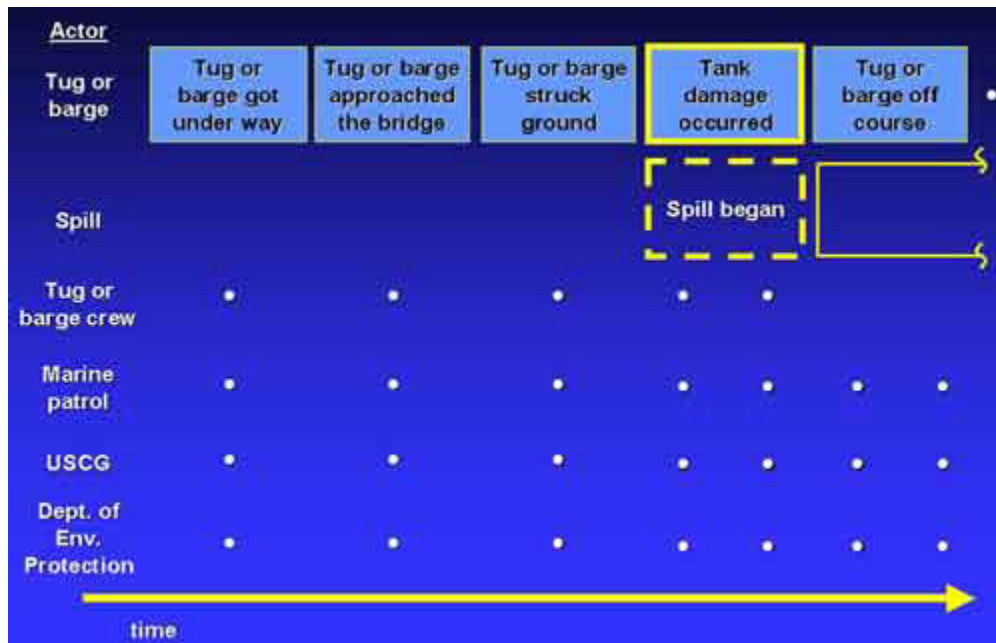

2.0 Select the accident. Define the accident of interest. If there is more than one accident, choose the last one to occur.



3.0 Define the primary sequence of events leading to the accident. Outline the *thumbnail sketch* of the sequence of events leading to the accident. Work backward from the accident, making certain that each subsequent event is the one that most directly leads to the previous event.



Draw events using the guidance in the table and bullets that follow.

- Draw events as rectangles.
 - Describe events specifically with one noun and one action verb.
 - Use quantitative descriptions when possible to characterize events.
 - Include the timing of the event when known.

- Use solid lines for known events and dashed lines for assumed events.
- Draw conditions as ovals.
 - Describe conditions specifically using a form of the verb *to be*.
 - Use quantitative descriptions to characterize conditions.
 - Include the timing and duration of the condition when known.
 - Use solid lines for known conditions and dashed lines for assumed conditions.

	Action	Condition
Fact		
Supposition		
Verb (Past Tense)	Active: walked, called, turned on, etc.	Passive: was, were

4.0 Complete the model by adding secondary events and conditions. Add secondary events and conditions as appropriate to ensure that all events and conditions leading to an accident are sufficient and necessary to cause the accident. Add events as appropriate to display the contributors to the secondary events and conditions.

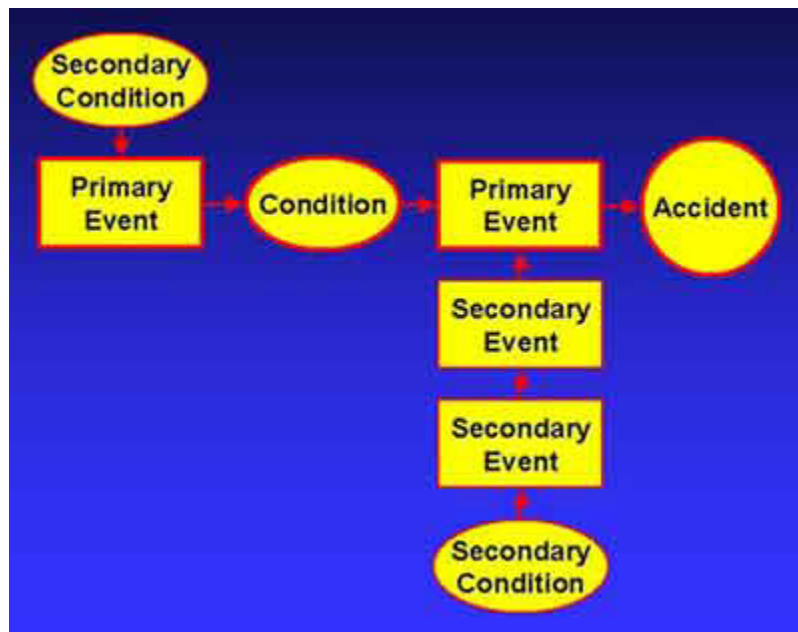

5.0 Identify causal factors and items of note. Designate the underlying contributors to the accident as causal factors. Document any items of note.

13. Personnel must demonstrate a familiarity level knowledge of the occurrence reporting and processing system necessary to ensure that occurrences are properly reported and processed in accordance with DOE M 231.1-2, *Occurrence Reporting and Processing of Operations Information*.

a. Define the term reportable occurrence, and using an actual facility-specific occurrence report, discuss the factors contributing to the occurrence.

The following definition of the term “reportable occurrence” is taken from Incident Investigation: DOE ORPS Reportable Investigation Procedure. The remainder of the KSA is performance-based. The Qualifying Official will evaluate its completion.

Strict investigation requirements and procedures apply to incidents that are determined to be recordable into the DOE occurrence reporting processing system (ORPS).

An ORPS incident is classified by the facility manager, facility manager designee, and/or the ORPS program manager. The classification is based on guidelines provided by the DOE and OSHA.

An ORPS reportable occurrence generally has these characteristics:

- Seriously affects the health and safety of personnel or the public
- Seriously impacts the intended work schedule of DOE facilities
- Has a noticeably adverse effect on the environment

b. List the conditions or events that require prompt and follow-up notification to DOE/NNSA.

The following is taken from DOE M 231.1-2.

The facility manager must notify the DOE facility representative and the DOE headquarters operations center (DOE HQ OC), as required, of the following reportable occurrences as soon as practical but no later than two hours after categorization:

- All significance category 1 occurrences require a prompt notification to the facility representative and DOE HQ OC.
- All significance category 2 occurrences require a prompt notification to the facility representative and, if directed by the facility representative, to the DOE HQ OC.
- All significance category 3 occurrences require a prompt notification to the facility representative.
- Additionally, specific significance category 2, 3, and 4 occurrences require prompt notification to the facility representative and DOE HQ OC.

The DOE HQ OC will relay notifications to the appropriate HQ-level program manager and make any further notifications, as required.

The facility manager may use the local field/site emergency OC to expedite establishing the communication link required and to record and archive conversations. The prompt notification process is as follows:

- The facility manager must e-mail the prompt notification of the reportable occurrence to the DOE HQ OC, and follow up with a phone call to the DOE HQ OC to ensure receipt of the e-mail.

- The prompt notification must clearly state/select the significance category (1, R, 2, 3, or 4) and identify the specific reporting criteria associated with the occurrence.
- Prompt notification to the DOE HQ OC must include information on the following items:
 - Occurrence significance category
 - Location and description of the event
 - Date and time of discovery
 - Damage and casualties
 - Impact of event on other activities and operations

c. Describe the importance of reporting between contractors and Federal workers and have a working knowledge of various reporting systems, requirements, and investigations.

The following is taken from DOE M 231.1-1

Heads of field elements will prepare an integrated annual site environmental report for each calendar year. This report must present summary environmental data to accomplish the following:

- Characterize site environmental management performance. Include data on effluent releases, environmental monitoring, and estimated radiological doses to the public from releases of radioactive material at DOE sites.
- Summarize environmental occurrences and responses reported during the calendar year.
- Confirm compliance with environmental standards and requirements.
- Highlight significant programs and efforts. Include environmental performance indicators and/or performance measures programs. The breadth and detail of this reporting should reflect the size and extent of programs at a particular site.

Heads of headquarters and field elements with responsibility for NEPA matters will perform the following:

- Submit an annual report to the Office of NEPA Policy and Compliance on progress in implementing, and the effectiveness of, any commitment for environmental impact mitigation that is essential to render the impacts of a proposed action not significant or that is made in a record of decision.
- The report may be submitted on the mitigation action plan anniversary or as part of a combined report for multiple plans until mitigation has been completed.
- Submit an annual NEPA planning summary to the general counsel by January 31 of each year and make it available to the public.

Heads of headquarters elements and heads of field elements will require DOE contractors to report work-related fatalities, injuries, and illnesses occurring among DOE contractor/subcontractor employees and arising out of work primarily performed at DOE-owned or DOE-leased facilities under their direction.

Report Submission—DOE F 5484.3

DOE F 5484.3 will be submitted electronically only, using either the CAIRS bulk upload processing or by entering information into the electronic form using CAIRS direct data entry. New reports will be submitted at least twice per month for receipt on or before the

15th of the month and the last working day of the month. Initial reports will include the actual work time lost as of the date the report is submitted. Revisions to lost work time will be submitted quarterly until the case is closed. Quarterly revisions for lost work time and any other information that requires revising information initially reported will be submitted for receipt by the 10th of the month following the end of the calendar quarter (i.e., April 10th, July 10th, October 10th, and January 10th). Prior to the transition to required electronic reporting only, legible copies of new and or revised report forms may be mailed. Mailed report forms should be addressed to the CAIRS data coordinator, U.S. Department of Energy, HS-30/Bldg. 270 CC, 1000 Independence Ave., S.W., Washington, DC 20585-0270.

Submission of Work Hours, DOE F 5484.4

DOE F 5484.4 will be submitted electronically only by entering information into the electronic form using CAIRS direct data entry. Quarterly work-hours will be submitted by the 10th of the month following the end of the quarter. Prior to the transition to electronic reporting only, legible copies of completed report forms may be mailed. Mailed report forms should be addressed to the CAIRS data coordinator, U.S. Department of Energy, HS-30/Bldg. 270 CC, 1000 Independence Ave., S.W., Washington, DC 20585-0270.

Posting OSHA Form 300A

OSHA form No. 300A, will be completed, certified, and posted annually.

d. Explain the relationship of ORPS to accident investigations identifying overlaps, contractor and Federal roles, and value for improving safety and health.

The following is taken from DOE M 231.1-2.

In general, the investigative process is used to gain an understanding of the occurrence, its causes, and the corrective actions necessary to prevent recurrence or only remedy the problem, based on the significance of the occurrence. If DOE is doing an investigation, the facility manager is not required to perform an identical investigation. However, the facility manager is still required to do the preliminary assembly of information to turn over to the DOE AIB, in accordance with DOE O 225.1B.

14. Occupational safety personnel must demonstrate a working level knowledge of the purpose, general content, development, and performance of worker occupational safety training.

a. Describe the requirements of DOE O 426.2, *Personnel Section, Training, Qualification, and Certification Requirements for DOE Nuclear Facilities*.

The following is taken from DOE O 426.2.

A selection, training, qualification and certification program (training program), as described in this Order must be implemented at new and existing hazard category 1, 2, and 3 DOE nuclear facilities, including activities and programs at government-owned and government-operated facilities.

Heads of field organizations/field element manager for NNSA operations or designee must evaluate and approve 1) the contractor training implementation matrix (TIM) or succeeding training program description or plan (TPP) and 2) contractor procedures that are established to release an individual from portions of a training program through prior education, experience, training, and/or qualification/certification.

Heads of field organizations/field element manager for NNSA operations or designee must evaluate contractor training and qualification programs using the methodology described in DOE-STD-1070-94, *Guidelines for Evaluation of Nuclear Facility Training Programs*.

During these evaluations heads of field organizations must verify that the TIM or TPP used to administer the contractor's training program meets the requirements of DOE O 426.2.

Heads of field organizations must provide the results of training program evaluations to the program secretarial officer and the HSS for information.

Heads of field organizations must ensure that the entire scope of DOE-STD-1070-94 that is applicable to their site is addressed at least once in each three-year interval. The evaluation program should apply a graded approach to the depth and level of effort of the evaluation, consistent with the hazards and complexity of the activities conducted at site facilities.

b. Describe the purpose of DOE O 426.1, *Federal Technical Capability in fielding a competent occupational safety workforce. Include a description of the Technical Qualification Program.*

The following is taken from DOE O 426.1.

The purpose of DOE O 426.1 is to define requirements and responsibilities for meeting the DOE commitment to recruiting, deploying, developing, and retaining a technically competent workforce that will accomplish DOE missions in a safe and efficient manner through the Federal Technical Capability Program (FTCP). The Department will strive to recruit and hire technically capable people; continuously develop the technical expertise of its existing workforce; and, within the limitations of executive policy and Federal law, retain critical technical capabilities within the Department at all times.

The following is taken from DOE M 426.1-1A.

Training, education, and experience combine to provide a workforce that ensures safe operation of defense nuclear facilities. The Technical Qualification Program (TQP) establishes a process to objectively determine that individuals performing activities related to the technical support, management, oversight, or operation of defense nuclear facilities possess the necessary knowledge, skills, and abilities to perform their assigned duties and responsibilities.

The TQP specifically applies to DOE technical employees whose duties and responsibilities require them to provide assistance, guidance, direction, oversight, or evaluation of contractor activities that could impact the safe operation of a defense nuclear facility. This includes employees designated as safety system oversight

personnel, facility representatives, and senior technical safety managers and employees on detail or temporary assignment.

c. Identify safety-training requirements addressed in applicable regulations or DOE Orders.

The following is taken from DOE G 440.1-1C.

Radiation safety training shall be provided to all individuals before being

- permitted unescorted access to controlled areas;
- occupationally exposed to ionizing radiation during access to controlled areas, whether escorted or not.

10 CFR 835 requires that radiation safety training shall include certain topics to the extent appropriate to the individual's prior training, work assignments, and degree of exposure to potential radiological hazards. Radiation safety training program requirements should be established in specific procedures that address, at a minimum, the issues discussed in DOE G 440.1-1C, *Radiation Protection Programs Guide for Use with Title 10, Code of Federal Regulations, Part 835, Occupational Radiation Protection*.

In addition to the radiation safety training requirements discussed in DOE G 440.1-1C, 10 CFR 835.103, "Education, Training, and Skills," establishes requirements for the education, training, and skills of individuals who are responsible for developing and implementing measures required to ensure compliance with 10 CFR 835. DOE G 440.1-1C, provides guidance for achieving compliance with these requirements.

To ensure that appropriate radiation safety training is provided to all individuals entering controlled areas, DOE has sponsored development of radiation safety training core course material for general employee radiological training and radiological worker training (RWT). RWT has been developed in a modular format to support two distinct core courses, RWT-I and RWT-II. RWT-II includes the material provided in RWT-I, augmented by additional modules on more complex radiation protection issues, such as high radiation area and contaminated area entry and exit controls.

The following is taken from the U.S. Department of Labor, Occupational Safety and Health Administration, OSHA 2254.

The Occupational Safety and Health Act of 1970 does not address specifically the responsibility of employers to provide health and safety information and instruction to employees, although section 5(a)(2) does require that each employer ". . . shall comply with occupational safety and health standards promulgated under this Act." However, more than 100 of the Act's current standards do contain training requirements.

Therefore, the OSHA has developed voluntary training guidelines to assist employers in providing the safety and health information and instruction needed for their employees to work at minimal risk to themselves, to fellow employees, and to the public.

The guidelines are designed to help employers 1) determine whether a worksite problem can be solved by training; 2) determine what training, if any, is needed; 3) identify goals and objectives for the training; 4) design learning activities; 5) conduct training; 6)

determine the effectiveness of the training; and 7) revise the training program based on feedback from employees, supervisors, and others.

The development of the guidelines is part of an agency-wide objective to encourage cooperative, voluntary safety and health activities among OSHA, the business community, and workers. These voluntary programs include training and education, consultation, voluntary protection programs (VPPs), and abatement assistance. The guidelines provide employers with a model for designing, conducting, evaluating, and revising training programs. The training model can be used to develop training programs for a variety of occupational safety and health hazards identified at the workplace. Additionally, it can assist employers in their efforts to meet the training requirements in current or future occupational safety and health standards.

A training program designed in accordance with these guidelines can be used to supplement and enhance the employer's other education and training activities. The guidelines afford employers significant flexibility in the selection of content and training and program design. OSHA encourages a personalized approach to the informational and instructional programs at individual worksites, thereby enabling employers to provide the training that is most needed and applicable to local working conditions.

Assistance with training programs or the identification of resources for training is available through such organizations as OSHA full-service area offices, state agencies which have their own OSHA-approved occupational safety and health programs, OSHA-funded state onsite consultation programs for employers, local safety councils, the OSHA Office of Training and Education, and OSHA-funded new directions grantees.

OSHA's training guidelines follow a model that consists of

- determining if training is needed
- identifying training needs
- identifying goals and objectives
- developing learning activities
- conducting the training
- evaluating program effectiveness
- improving the program

The model is designed to be one that even the owner of a business with very few employees can use without having to hire a professional trainer or purchase expensive training materials. Using this model, employers or supervisors can develop and administer safety and health training programs that address problems specific to their own business, fulfill the learning needs of their own employees, and strengthen the overall safety and health program of the workplace.

d. Discuss basics of training development techniques, emphasizing the importance of using behavioral objectives.

The following is taken from Benjamin Bloom's Taxonomy of Behavioral Objectives.

In 1956, Benjamin Bloom headed a group of educational psychologists who developed a classification of levels of intellectual behavior important in learning. This became a taxonomy, including three overlapping domains: the cognitive, affective and psychomotor.

Cognitive learning is demonstrated by knowledge recall and the intellectual skills: comprehending information, organizing ideas, analyzing and synthesizing data, applying knowledge, choosing among alternatives in problem-solving, and evaluating ideas or actions. This domain on the acquisition and use of knowledge is predominant in the majority of courses. Bloom identified six levels within the cognitive domain, from the simple recall or recognition of facts, as the lowest level, through increasingly more complex and abstract mental levels, to the highest order which is classified as evaluation. Verb examples that represent intellectual activity on each level are listed here, and each level is linked to questions appropriate to the level.

- Knowledge: arrange, define, duplicate, label, list, memorize, name, order, recognize, relate, recall, repeat, reproduce, state
- Comprehension: classify, describe, discuss, explain, express, identify, indicate, locate, recognize, report, restate, review, select, translate
- Application: apply, choose, demonstrate, dramatize, employ, illustrate, interpret, operate, practice, schedule, sketch, solve, use, write
- Analysis: analyze, appraise, calculate, categorize, compare, contrast, criticize, differentiate, discriminate, distinguish, examine, experiment, question, test
- Synthesis: arrange, assemble, collect, compose, construct, create, design, develop, formulate, manage, organize, plan, prepare, propose, set up, write
- Evaluation: appraise, argue, assess, attach, choose, compare, defend, estimate, judge, predict, rate, core, select, support, value, evaluate

Affective learning is demonstrated by behaviors indicating attitudes of awareness, interest, attention, concern, and responsibility, ability to listen and respond in interactions with others, and ability to demonstrate those attitudinal characteristics or values which are appropriate to the test situation and the field of study. This domain relates to emotions, attitudes, appreciations, and values, such as enjoying, conserving, respecting, and supporting. Verbs applicable to the affective domain include accepts, attempts, challenges, defends, disputes, joins, judges, praises, questions, shares, supports, and volunteers.

Psychomotor learning is demonstrated by physical skills: coordination, dexterity, manipulation, grace, strength, speed; actions which demonstrate the fine motor skills such as use of precision instruments or tools, or actions which evidence gross motor skills such as the use of the body in dance or athletic performance. Verbs applicable to the psychomotor domain include bend, grasp, handle, operate, reach, relax, shorten, stretch, write, differentiate (by touch), express (facially), perform (skillfully).

e. Discuss concepts of behavior modification and performance improvement.

The following is taken from the Encyclopedia of Mental Disorders, Behavior Modification.

Behavior modification is based on the principles of operant conditioning, which were developed by American behaviorist B.F. Skinner. Skinner formulated the concept of operant conditioning, through which behavior could be shaped by reinforcement or lack of it. Skinner considered his concept applicable to a wide range of both human and animal behaviors and introduced operant conditioning to the general public in his 1938 book, *The Behavior of Organisms*.

One behavior modification technique that is widely used is positive reinforcement, which encourages certain behaviors through a system of rewards. In behavior therapy, it is common for the therapist to draw up a contract with the client establishing the terms of the reward system.

Another behavior modification technique is negative reinforcement. Negative reinforcement is a method of training that uses a negative reinforcer. A negative reinforcer is an event or behavior whose reinforcing properties are associated with its removal. For example, terminating an existing electric shock after a rat presses a bar is a negative reinforcer.

In addition to rewarding desirable behavior, behavior modification can also discourage unwanted behavior, through punishment. Punishment is the application of an aversive or unpleasant stimulus in reaction to a particular behavior. The removal of reinforcement altogether is called extinction. Extinction eliminates the incentive for unwanted behavior by withholding the expected response.

f. Discuss considerations for the development of a training course. Describe the various types (and uses) of training material and techniques.

The following is taken from DOE-HDBK-1078-94.

Training methods selected should be based on the objectives and settings for the course. Training methods are techniques of communicating instructional material to trainees. They include lecture, demonstration/practice, discussion/facilitation, oral questioning, role playing, walkthrough, and self-pacing. Characteristics of each of these methods are found in table 20.

Although discussion and oral questioning have general application in all training settings, other methods are more effective in certain training settings. Examples of other methods include the following techniques:

- Lecture generally is considered more appropriate for the classroom.
- Demonstration and practice applies primarily to on-the-job training (OJT) and laboratory and simulator training, although it can also be used in the classroom.
- Role playing is particularly effective during simulator drills and exercises that involve team training.
- Walkthroughs serve to enhance training that is conducted in training settings where the job environment is simulated.
- Self-pacing is a method generally reserved for self-study.

Table 20. Training methods

Method	Characteristics
Lecture	<p>A public-speaking-type presentation</p> <p>Effective and efficient with large groups of trainees</p> <p>Typically used in classroom settings</p> <p>Body of information that is well-organized, condensed, and presented in logical steps</p> <p>Presentation provides periodic pauses for asking and answering questions to determine trainee comprehension</p> <p>Conclusion provides a summary of key points.</p>
Demonstration/Practice	<p>A presentation in which the exact procedures (skills) are shown in step-by-step sequence by the instructor</p> <p>More effective with small groups of trainees</p> <p>Limited to laboratory/workshop, OJT, and simulator training, when use of equipment is involved</p> <p>Performance of each step and its relationship to the overall procedure is emphasized by the instructor</p> <p>Trainee performs the step-by-step procedure under instructor supervision until proficiency is achieved.</p>
Discussion/Facilitation	<p>Conversation is guided between trainees, with direction from the instructor or group leader</p> <p>More effective with small groups of trainees</p> <p>Typically used in classroom settings</p> <p>A discussion leader is appointed for each group</p> <p>Provides for use of case studies</p> <p>Provides opportunity for trainees to observe, listen, and actively participate in the learning activity</p>
Oral Questioning	<p>Instructor asks specific questions of different trainees (not always those who volunteer the answer) to increase interaction and control the pace of the training</p> <p>Permits direct interaction between the instructor and trainees</p> <p>Appropriate to all settings</p> <p>Samples trainee comprehension of the material</p>

Method	Characteristics
Role Playing	<p>Trainees assume roles (responsibilities) in a real or simulated job environment</p> <p>Develops an understanding of roles and the importance they play in the job environment</p> <p>Permits instructor observation of trainee attitudes, philosophies, and personality traits</p> <p>Appropriate to all settings except self-pacing</p> <p>Effective in learning team member functions and team response coordination</p> <p>Particularly effective during exercises and drills</p>
Walkthrough	<p>Trainees experience actual job environment</p> <p>Used to facilitate trainees' transition from learning in a simulated environment to application in the job environment</p> <p>Limited to a discussion of action steps within the actual job environment</p> <p>Emphasizes physical facility layouts, spatial relationships, equipment location, and observation of trained employees performing their jobs</p> <p>Places the course learning objectives in a job context that increases trainee motivation and allows active participation</p> <p>Permits a sampling of trainee comprehension of the learning activity</p>
Self-pacing	<p>The pace of training is controlled by the trainee (i.e., a lesson stops when a trainee fails to respond and remains stopped until the trainee responds)</p> <p>Frequently used during remedial training</p>

Source: DOE-HDBK-1078-94

g. Discuss basics of evaluating a training course or program and the importance of, and methods for, evaluating occupational safety training effectiveness.

The following is taken from DOE-HDBK-1078-94.

The evaluation phase of performance-based training takes place in order to determine the effectiveness of the training program. Evaluation is the QA component of the performance-based training model. There are three major activities involved in evaluation: monitoring of indicators, analyzing information, and initiating corrective actions.

Monitoring of Indicators

Data should be collected for each indicator that provides the best indication of training effectiveness. While this data collection should be continuous in many cases, it is a batch process. In these cases, the frequency for which these items are reviewed should be

determined based on the frequency management feels is necessary to ensure the currency of the training program.

Analyze Information

Program evaluation information must be analyzed before it can be used to make changes in training. The simplest method of analysis that will yield the information required should be used. Analysis methods include exception analysis and content analysis. Some types of data should be organized and tabulated using frequency distributions prior to analysis. Apparent performance discrepancies must also be verified through discussions with appropriate personnel.

Initiate Corrective Actions

If a performance discrepancy or potential problem is discovered and analysis confirms that training can contribute to a solution, action should be initiated to correct the existing or potential problem. Training modifications initiated because of existing deficiencies in personnel performance and those resulting from changing needs should be processed in a similar manner. Improvements and changes to training should be initiated and tracked systematically. Analysis results should be retained to document evaluation activities and indicators should continue to be monitored. Because of the amount of work and cost involved, any decision to modify training should be carefully considered. Each facility should establish a procedure for deciding whether or not training should be changed, how it should be changed, and to whom the new or modified training should be provided. Improvements or revisions involving any phase of the training process should be completed in a timely manner. Since some performance deficiencies can be eliminated by better implementation of an existing program, with no changes in the program itself, this should be considered.

h. Describe the role and limitations of worker training in a comprehensive safety program.

The following is taken from DOE-STD-1032-92.

Management must strive to develop and maintain a proper safety attitude in all facility personnel. A comprehensive safety program must include planning for safety. If safety planning accompanies work planning, safety issues will be confronted before actual work is started. Planning will minimize work holdups and operating schedule delays that result from correcting safety issues. Personnel must also be trained in safe operating practices and the need to identify potential personnel hazards at their work stations. Management monitoring of performance, stressing safety and planning for safety will reinforce this attitude.

i. Describe the role and value of a job safety analysis as a training tool.

The following is taken from the DOE FEOSH Program Review, Workplace Inspections, Hazards Analysis and Abatement.

Job safety analyses (JSAs) are step-by-step analyses of each job component and existing or potential hazards. They should be performed by supervisors and workers and supplemented by the safety and health staff. JSAs should be performed initially for all operations and then updated as operations change.

JSA's are the most basic and widely used tool to identify job and task hazards and prevent accidents before they occur. JSA's can satisfy a large portion of the hazard identification tasks at a facility. These analyses are appropriate for dynamic activities and tasks, such as construction projects; however, static work environments are also appropriate for using JSA's.

Quick completion time and limited resource allocation make JSA's a very adaptable and widely used hazard identification technique. A JSA is performed by breaking down a job into its component steps and then examining each job component to determine hazard and accident causes or those that may potentially occur. Reviewing the job steps and hazards while the employee performs the job will ensure that a comprehensive and accurate list of hazards is identified and documented.

Consideration must be given to job mobility, area of performance, ongoing operations in surrounding areas, specific hazards in the area, relative age of the workforce and job experience, applicable safety and health rules, and recognition of abnormal or unforeseen problems.

JSA's benefit new employees by providing a basis for them to perform their jobs. Likewise, experienced employees also benefit by undergoing a safety awareness "reality check" on their job.

j. Identify the key elements of HAZWOPER training as defined in 29 CFR 1910.120, Appendix E.

The following is taken from 29 CFR 1910.120, appendix E.

Suggested core criteria:

Training Facility

The training facility should have available sufficient resources, equipment, and site locations to perform didactic and hands-on training when appropriate. Training facilities should have sufficient organization, support staff, and services to conduct training in each of the courses offered.

Training Director

Each training program should be under the direction of a training director who is responsible for the program. The training director should have a minimum of two years of employee education experience.

Instructors

Instructors should be deemed competent on the basis of previous documented experience in their area of instruction, successful completion of a "train-the-trainer" program specific to the topics they will teach, and an evaluation of instructional competence by the training director.

Instructors should be required to maintain professional competency by participating in continuing education or professional development programs or by completing successfully an annual refresher course and having an annual review by the training director. The annual review by the training director should include observation of an

instructor's delivery, a review of those observations with the trainer, and an analysis of any instructor or class evaluations completed by the students during the previous year.

Course Materials

The training director should approve all course materials to be used by the training provider. Course materials should be reviewed and updated at least annually. Materials and equipment should be in good working order and maintained properly. All written and audio-visual materials in training curricula should be peer-reviewed by technically competent outside reviewers or by a standing advisory committee. Reviewers should possess expertise in the following disciplines where applicable: occupational health, IH and safety, chemical/environmental engineering, employee education, or emergency response. One or more of the peer reviewers should be an employee experienced in the work activities to which the training is directed.

Students

The program for accepting students should include

- assurance that the student is or will be involved in work where chemical exposures are likely and that the student possesses the skills necessary to perform the work
- a policy on the necessary medical clearance

Ratios

Student-instructor ratios should not exceed 30 students per instructor. Hands-on activity requiring the use of PPE should have the following student-instructor ratios. For level C or level D PPE the ratio should be 10 students per instructor. For level A or level B PPE the ratio should be 5 students per instructor.

Proficiency Assessment

Proficiency should be evaluated and documented by the use of a written assessment and a skill demonstration selected and developed by the training director and training staff. The assessment and demonstration should evaluate the knowledge and individual skills developed in the course of training. The level of minimum achievement necessary for proficiency shall be specified in writing by the training director. If a written test is used, there should be a minimum of 50 questions. If a written test is used in combination with a skills demonstration, a minimum of 25 questions should be used. If a skills demonstration is used, the tasks chosen and the means to rate successful completion should be fully documented by the training director. The content of the written test or of the skill demonstration shall be relevant to the objectives of the course. The written test and skill demonstration should be updated as necessary to reflect changes in the curriculum and any update should be approved by the training director. The proficiency assessment methods, regardless of the approach or combination of approaches used, should be justified, documented, and approved by the training director.

15. Occupational safety personnel must demonstrate a working level knowledge of Motor Vehicle Safety.

a. Identify safe driving and defensive driving techniques.

The following is taken from the DOE Motor Vehicle Management Handbook.

DOE organizations and contractors should ensure that employees operating government motor vehicles are informed concerning the following:

- The statutory requirement that government motor vehicles are to be used only for official purposes
- The penalties for unauthorized use of government motor vehicles
- Personal responsibility for safe driving and operation of government motor vehicles as to prevent injury to self, others and for safeguarding property from damage
- Compliance with Federal, state, and local laws and regulations
- Fueling requirements for the vehicle
- Accident reporting requirements
- The need to possess a valid state, District of Columbia, or commonwealth operator's license or permit for the type of vehicle to be operated and some form of agency identification
- The prohibition against providing transportation to strangers or hitchhikers
- The proper care, control and use of government credit cards
- The mandatory use of seat belts by each employee operating or riding in a government motor vehicle
- The prohibition against the use of tobacco products in Government Services Administration (GSA) fleet and DOE-owned motor vehicles
- The discouraged use of hand-held wireless telephones while operating a moving government motor vehicle

Defensive Driving Tips

The following is taken from the *Missouri Driver Guide*, chapter 8.

To avoid making mistakes or being in an accident because of someone else's mistake, a driver must drive defensively. A defensive driver should follow these tips:

- Keep your eyes moving. Notice what is happening ahead of you and on the sides of the road, and check behind you through your mirrors every few seconds. Pay special attention to oncoming vehicles. Many head-on collisions occur by distracted drivers crossing the centerline.
- Expect other drivers to make mistakes, and think what you would do if a mistake does happen. For example: do not assume that a vehicle coming to a stop sign is going to stop. Be ready to react if it does not stop. Never cause an accident on purpose, even if a pedestrian or another vehicle fails to give you the right-of-way.
- Do not rely on traffic signals or signs to keep others from crossing in front of you. Some drivers may not obey traffic signals or signs. At an intersection, look to the left and right, even if other traffic has a red light or a stop sign.

b. Discuss pre- and post-driving vehicle inspections.

The following is taken from 49 CFR 396.13.

Before driving a motor vehicle, the driver shall

- be satisfied that the motor vehicle is in safe operating condition;
- review the last driver vehicle inspection report;
- sign the report, only if defects or deficiencies were noted by the driver who prepared the report, to acknowledge that the driver has reviewed it and that there is a certification that the required repairs have been performed. The signature

requirement does not apply to listed defects on a towed unit which is no longer part of the vehicle combination.

The following is taken from 49 CFR 396.15.

Pre-trip inspection. Before the beginning of any driveaway-towaway operation of motor vehicles in combination, the motor carrier shall make a careful inspection and test to ascertain that

- the tow bar or saddle-mount connections are properly secured to the towed and towing vehicle
- they function adequately without cramping or binding of any of the parts
- the towed motor vehicle follows substantially in the path of the towing vehicle without whipping or swerving

Post-trip inspection. Motor carriers shall maintain practices to ensure that following completion of any trip in driveaway-towaway operation of motor vehicles in combination, and before they are used again, the tow bars and saddle-mounts are disassembled and inspected for worn, bent, cracked, broken, or missing parts. Before reuse, suitable repair or replacement shall be made to any defective parts and the devices shall be properly reassembled.

c. Discuss how the application and use of control measures, equipment, road conditions, and barriers are effected by environmental conditions.

The following is taken from RTW Colorado, Inc., Loss Prevention Info Sheet, Rules of the Road—Safe Driving Tips.

Weather Conditions

Weather can create a driving hazard. Special care must be taken in fog, rain, high winds, and winter driving conditions. It is best not to drive in fog; however, if you must drive, take the following precautions:

- Slow down. If you see headlights or taillights, slow down even more. A driver may be driving in the center of the roadway or may be stopped or barely moving.
- Drive with your headlights set on dim, or use fog lights.
- Do not overdrive your headlights. Stay within the limits of your vision. You may have to stop suddenly. If the fog is too dense, pull off the roadway and stop. Do not drive at 5 or 10 miles per hour.
- Use your turn signal long before you turn and brake early when you approach a stop to warn other drivers.

When rain begins to fall lightly, water, dust, oil, and leaves can cause the roadway to become slippery. When this happens, increase your following distance. Take special care on curves and turns and while braking. Your headlights must be on when operating your wipers. Parking lights are not acceptable.

When rain begins to fall heavily, your tires may “hydroplane.” This means the tires are riding on a layer of water and not on the roadway. Avoid hydroplaning by slowing down. If you skid while hydroplaning, try to regain control of the vehicle. Otherwise, release the accelerator and ride out the skid.

Wind can be a difficult problem for all drivers. Wind is especially difficult for drivers of trucks, recreational vehicles, campers, and trailers-in-tow. In high winds, you should reduce your speed and make steering corrections when you go from a protected area to an open area and when meeting large vehicles such as trucks and buses. Heavy rain or sleet often accompanies high winds. You should be alert to wet or slippery areas and plan for those conditions.

Winter driving is the most difficult driving season due to many reasons, including ice, snow, lower temperatures and fewer daylight hours. When driving in winter conditions observe the following precautions:

- Drive more slowly and increase your following distance. Roadway conditions may vary depending on the sun, shade, or roadway surface.
- Remove all snow and ice from your vehicle. Clear all windows, and do not start driving until your windshield is defrosted and clear. Be sure you have non-freezing windshield washer liquid and that your headlights and taillights are visible.
- Be sure your vehicle is maintained properly. Lights, brakes, windshield wipers, defrosters, radiator, and other parts should be in good working order.
- Use snow tires and/or chains (where allowed). Snow tires give you extra traction, and chains increase safety on snow or ice packed roads. Neither tires nor chains allow you to drive on bad roads at normal speeds.
- Start slowly. Gentle braking, in slow, steady strokes, helps you find out how much traction you have. Begin braking early when you come to an intersection or a stop.
- Approach bridges, shaded spots, overpasses, and turns slowly. They may remain icy after the rest of the roadway is clear and dry.
- Plan your winter driving. Carry a blanket, food, and other survival equipment such as a shovel, in your vehicle in case you become stranded. If you become stranded, remain in your vehicle. Run your engine only for brief times, and open your window to prevent carbon monoxide poisoning. Make sure your vehicle tailpipe is free of snow and debris.

Equipment Failure

Crashes often happen when equipment fails. The most important aid is remaining calm. Equipment failures may include

- blowouts
- loss of the wheel
- steering failure
- brake failure
- headlight failure
- stuck gas pedal
- blocked vision

d. Discuss actions and procedures for reporting vehicle accident or property damage.

The following is taken from the DOE Motor Vehicle Management Handbook.

Accident Reporting Procedures

Employees will take the following action when involved in a motor vehicle accident:

- Notify or have the supervisor notify the following persons or offices in person or by telephone:
 - The state, county, or municipal authorities, as required by law
 - The accident management center for GSA fleet vehicles
 - His/her supervisor
 - The contractor, when operating a commercially leased or rented vehicle
 - The safety officer for your site location

- Take the following action at the scene of the accident or follow your site's established guidelines:
 - Obtain the name, address, telephone number, operator's permit number, vehicle license number, insurance company name, policy number, and claims address from the other driver, as well as any other information necessary to complete the accident report forms.
 - Obtain the names, addresses, and telephone numbers of any witnesses, and whenever possible have witness complete the SF 94, *Statement of Witness*.
 - Give his or her name, address, telephone number, permit number, vehicle license number, and agency identification to the other driver(s) and the police when requested to do so.
 - Ask the police officer to collect the required information if personal injury prevents collecting it, and contact the supervisor, who will complete and process the forms.
 - Obtain a police investigation report, photographs, doctor's certification of bodily injuries, and any other pertinent documentation concerning the accident if possible; this information should be processed with all required accident report forms not later than five working days after the accident
 - Complete the following applicable forms:
 - SF 91, Operator's Report of Motor Vehicle Accident
 - SF 94, Statement of Witness

Property Damage

The cost of damage caused to a vehicle that adversely affects the resale of a vehicle should be recovered from the vehicle user when it has been determined that the damage was caused by negligence or willful misconduct by the user.

Contractors should charge the user organization for all costs resulting from damage to a DOE vehicle that occurs while the vehicle is assigned to an employee of that organization. The recovered charges will be used to repair the vehicle. Organizations should be charged for

- vandalism, theft, and parking lot damage;
- damage caused by misuse or abuse inconsistent with normal operation and local conditions;
- repair costs which are incurred as a result of the user's failure to obtain required preventive maintenance; and
- unauthorized purchases or repairs, including credit card misuse, provided there is a clear, flagrant, and documented pattern of such occurrences.

Costs excluded from recovery. The user organization should not be charged for damage that results from

- the negligent or willful act of a party other than the organization or its employee and the responsible party has been determined;
- mechanical failure and the employee was not otherwise negligent; proof of the failure must be provided;
- normal wear comparable to similar vehicles; and
- acts of nature or natural disasters.

e. Discuss OSHA requirements for safer use of powered industrial trucks (see 29 CFR 1910.178, “Powered Industrial Trucks.”)

The following is taken from 29 CFR 1910.178.

29 CFR 1910.178 contains safety requirements relating to fire protection, design, maintenance, and use of fork trucks, tractors, platform lift trucks, motorized hand trucks, and other specialized industrial trucks powered by electric motors or internal combustion engines.

All new powered industrial trucks acquired and used by an employer shall meet the design and construction requirements for powered industrial trucks established in ANSI B56.1-1969.

Approved trucks shall bear a label or some other identifying mark indicating approval by the testing laboratory.

Modifications and additions which affect capacity and safe operation shall not be performed by the customer or user without manufacturer’s prior written approval. Capacity, operation, and maintenance instruction plates, tags, or decals shall be changed accordingly.

If the truck is equipped with front-end attachments other than factory installed attachments, the user shall request that the truck be marked to identify the attachments and show the approximate weight of the truck and attachment combination at maximum elevation with load laterally centered.

The user shall see that all nameplates and markings are in place and are maintained in a legible condition.

The term, “approved truck” or “approved industrial truck” means a truck that is listed or approved for fire safety purposes for the intended use by a nationally recognized testing laboratory, using nationally recognized testing standards.

Power-operated industrial trucks shall not be used in atmospheres containing hazardous concentration of acetylene, butadiene, ethylene oxide, hydrogen (or gases or vapors equivalent in hazard to hydrogen, such as manufactured gas), propylene oxide, acetaldehyde, cyclopropane, diethyl ether, ethylene, isoprene, or unsymmetrical dimethyl hydrazine.

Power-operated industrial trucks shall not be used in atmospheres containing hazardous concentrations of metal dust, including aluminum, magnesium, and their commercial alloys, other metals of similarly hazardous characteristics, or in atmospheres containing

carbon black, coal or coke dust except approved power-operated industrial trucks designated as EX may be used in such atmospheres.

In atmospheres where dust of magnesium, aluminum, or aluminum bronze may be present, fuses, switches, motor controllers, and circuit breakers of trucks shall have enclosures specifically approved for such locations.

Fuel Handling and Storage

The storage and handling of liquid fuels such as gasoline and diesel fuel shall be in accordance with NFPA No. 30, *Flammable and Combustible Liquids Code*.

The storage and handling of liquefied petroleum gas fuel shall be in accordance with NFPA No. 58, *Storage and Handling of Liquefied Petroleum Gases*.

Changing and Charging Storage Batteries

Battery charging installations shall be located in areas designated for that purpose.

Facilities shall be provided for flushing and neutralizing spilled electrolyte, for fire protection, for protecting charging apparatus from damage by trucks, and for adequate ventilation.

f. Describe bicycle and pedestrian hazards and controls.

The following is taken from Louisville, Kentucky Government, Bicycle and Pedestrian Safety.

Safe driving precautions around pedestrians include the following:

- Increase your defensive driving scan and search to include pedestrians along the road and on the sidewalks.
- Keeping the windshield clean, so that pedestrians are more visible, is one of the biggest things to reduce pedestrian accidents.
- Slow down and pay attention to signs indicating the presence of pedestrians.
- Be alert to pedestrians during left-hand turns. Just as with cyclists, a pedestrian is four times more likely to be hit by a motor vehicle that is turning left than by one that is turning right. The left turning maneuver is more demanding, particularly for older drivers.
- Be aware that children under eight years old are not capable of safely navigating around traffic. The American Academy of Pediatrics reports that a young child's awareness of sounds and the direction from which they emanate and their peripheral vision are not sufficiently developed until after eight years of age.
- Expect students around schools and colleges to be darting out, not paying attention to signals or traffic, or trying to catch the tail end of a walk signal, ending up still in the road when the light turns green.
- Be alert to unusual pedestrian behavior around construction areas.

16. Occupational safety personnel must demonstrate a working level knowledge of the requirements and methods to maintain communication with DOE-Headquarters, field elements (including contractors), other Federal agencies, and regulatory agencies.

a. Describe the DOE's safety organization and discuss DOE's procedures for communicating between DOE-Headquarters and Field Elements.

The following is taken from DOE M 411.1-1C.

The Secretary of Energy has the primary responsibility for ensuring that work at DOE facilities and sites is performed in a manner that adequately protects the worker, the public, and the environment. This responsibility flows from the Secretary of Energy through line management to the individuals performing the work. Specific responsibilities and authorities for all individuals contained in DOE's organizational chart are listed in DOE M 411.1-1C.

The following is taken from the Office of Health, Safety, and Security, Who We Are.

Background: On October 1, 2006, the Secretary of Energy created the HSS to integrate DOE headquarters-level functions for health, safety, environment, and security into one unified office. To accomplish this important responsibility, HSS is focused on providing the Department with effective and consistent policy development, technical assistance, education and training, complex-wide independent oversight, and enforcement. Additionally, HSS addresses Department-wide cross-cutting issues and enhances collaboration and sharing of technical expertise.

Organization: HSS is organized to promote the sharing and integration of information and to ensure clear responsibilities and accountability for these important functions within the organization. Details and information about the various elements of HSS can be found using the interactive organizational chart.

HSS is DOE's central organization responsible for health, safety, environment, physical security and information security. The office provides corporate-level leadership and strategic vision to coordinate and integrate these vital programs. HSS has five major roles across these areas of safety and security:

1. Facilitate development of departmental policy and requirements.
2. Provide mission support to the under secretaries and their line organizations.
3. Work to improve competencies of the Federal and contractor workforce in safety and security through the National Training Center in Albuquerque, NM.
4. Implement enforcement programs for the Department's self-regulation of nuclear safety, worker health and safety, and information security.
5. Provide feedback to senior management through independent oversight inspections and reviews of contractor and DOE performance in safety and security.

HSS strives to maintain a close working relationship with the NNSA administrator and the under secretaries of Energy and Science. To promote this relationship and to obtain feedback on issues related to health, safety, environment, and security, HSS senior management conducts visits throughout the DOE complex and meets with program and

site offices, contractor management, and union representatives, as well as, other Federal agencies, industry, academia, and other DOE stakeholders.

In March 2006 HSS formed the health, safety and security manager's focus group to solicit, discuss, and address topics and issues of interest to DOE managers and stakeholders to further the improvement of health, safety, environmental, and security performance within the Department. The HSS focus group has met with, and continues dialogue and exchange, with program secretarial offices, DOE stakeholders, and labor unions in this effort. In addition, the HSS hosts a visiting speaker program, which draws leaders from academia, business, public and private enterprise, and other organizations with interests similar to DOE to present on topics such as organizational theory, the business model of sustainability, resilience in challenging circumstances, and issues of global importance.

b. Describe DOE's procedures and policies (including formal Memorandums of Understanding) for communicating with other Federal or regulatory agencies.

The following is taken from DOE G 440.1-8.

All contractors and subcontractors must coordinate to ensure clear roles, responsibilities, and procedures to achieve an integrated approach to ensuring the safety and health of the worker consistent with 10 CFR 851.11, "Development and Approval of Worker Safety and Health Program." When multiple contractors, subcontractors, and Federal organizations are working on the same DOE site, resolving safety and health issues between the organizations can be confusing. For this reason, clear statements of roles and responsibilities with respect to compliance with worker safety and health program requirements and mechanisms for resolution of these issues should be clearly defined. Good lines of communication between the affected parties are essential and should be included in agreements between parties. The nature and extent of the organizational relationships vary from situation to situation. The need for a firmly established agreement between affected parties regarding worker safety and health program requirements is essential. Cognizant secretarial officers and heads of DOE field elements should evaluate the need for and, where necessary, support the development of formal written agreements between organizations on their sites. Such agreements would outline the respective roles, responsibilities, and authorities of each contractor or organization as they relate to compliance with all components of the worker safety and health program and the resolution of cross-cutting worker protection issues. Coordination agreements need not be highly detailed as long as roles, responsibilities, and procedures are sufficiently addressed to ensure that the rule is consistently implemented.

Some common written instruments used at DOE facilities to document and communicate agreements between multiple organizations are the contract, the lease agreement (for tenant organizations), the MOU, the MOA, and the intraservice support agreement. Authorization agreements used at high hazard nuclear facilities may also provide a vehicle for clarifying worker safety and health roles and responsibilities. These and other documents are usually prepared to identify roles and responsibilities of respective parties in these shared situations. The roles, responsibilities, and procedures contained in these agreements should be clearly addressed in the written safety and health program to ensure that they are adequately communicated throughout the site.

c. Define the respective jurisdictions of DOE and OSHA concerning occupational safety and health matters on DOE work sites.

The following is taken from the Memorandum of Understanding between the U.S. Department of Labor and the U.S. Department of Energy, 6/19/1995.

The Occupational Safety and Health Act (OSH Act) grants OSHA the authority to prescribe and enforce standards or regulations affecting the occupational safety and health of private-sector employees. However, section 4(b)(1) of the act waives OSHA's jurisdiction in cases where another Federal agency has exercised its statutory authority to prescribe or enforce occupational safety and health standards. Relying on this section of the act, the U.S. Department of Labor (DOL), in 1974, explicitly recognized the Atomic Energy Commission's (AEC's) authority to establish and enforce occupational safety and health standards at AEC-sponsored contractor facilities. Subsequently, DOL and DOE, the successor agency to the AEC, acknowledged this agreement in the August 10, 1992, MOU between the two departments. As specified in the original agreement and in the 1992 MOU, this DOE exemption from OSHA enforcement has applied only to those government-owned contractor-operated (GOCO) facilities for which DOE exercises its statutory authority pursuant to the Atomic Energy Act of 1954; OSHA has exercised enforcement authority over all other DOE facilities.

In the twenty years that have intervened since the signing of the original 1974 agreement, DOE has exercised its authority over working conditions at its GOCO facilities by developing and promulgating DOE Orders and conducting an extensive program of internal oversight at these facilities. In May 1993, Secretary O'Leary announced that DOE would immediately begin the process of shifting from internal oversight of occupational safety and health to external enforcement by OSHA.

The following is taken from 29 CFR 1960.16.

Each agency head shall comply with all OSHA standards issued under section 6 of the act, or with alternate standards issued pursuant to 29 CFR 1960, subpart C, "Standards." In addition to complying with emergency temporary standards issued under section 6 of the act, an agency head shall adopt such emergency temporary and permanent supplementary standards as necessary and appropriate for application to working conditions of agency employees for which there exists no appropriate OSHA standards.

There are situations in which the head of an agency is required to comply with standards affecting occupational safety and health issued by a Federal agency other than OSHA. For example, standards issued by the Federal Aviation Administration, DOE, or the General Services Administration may be applicable to certain Federal workplaces. In addition, agency heads should comply with other standards issued by Federal agencies that deal with hazardous working conditions, but for which OSHA has no standard.

Executive Order (EO) 12196, "Occupational Safety and Health Programs for Federal Employees," requires that each agency utilize as inspectors "personnel with equipment and competence to recognize hazards." Inspections shall be conducted by inspectors qualified to recognize and evaluate hazards of the working environment and to suggest general abatement procedures. Safety and health specialists as defined in 29 CFR 1960.2, "Definitions," section(s), with experience and/or up-to-date training in occupational

safety and health hazard recognition and evaluation are considered as meeting the qualifications of safety and health inspectors.

d. Describe methods DOE uses to inform contractors of the need for improvements, including notices of violation, contract actions, formal and informal communications. Identify who or which organizations have authority to conduct these communications.

The following is taken from 10 CFR 820.24.

If the DOE director has reason to believe a person has violated or is continuing to violate a provision of the Atomic Energy Act or a DOE nuclear safety requirement, he may file a preliminary notice of violation. The notice and any transmittal documents shall contain sufficient information to fairly apprise the respondent of the facts and circumstances of the alleged violations and the basis of any proposed remedy, and to properly indicate what further actions are necessary by or available to respondent. Within 30 days after the filing of a preliminary notice of violation, the respondent shall file a reply.

The following is taken from DOE G 120.1-5.

The strategic management system defines how the Department expects to manage for results, and comply with the requirements of Government Management Reform Act, other laws, and an Executive Order. The strategic management system was approved for implementation by the Secretary on March 4, 1996. The vision is that all organizations within the Department implement performance measurement systems to support their own planning and evaluation and that these measurement systems are part of the Department's strategic management system. When approved, the strategic management system was primarily a road map—a unifying theme for applying performance-based management within the Department.

Contractor performance measurement system is automatically part of DOE's strategic management system that is designed to maintain appropriate management and performance information at each level of the organization.

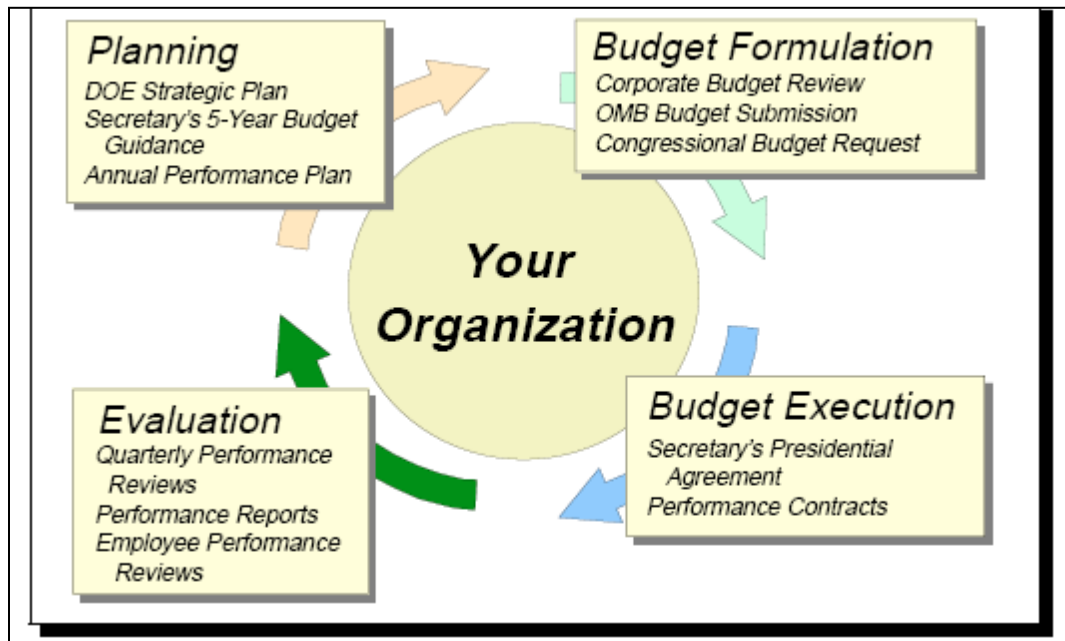

Source: DOE G 120.1-5

Figure 7. Performance measurement in the strategic management system

Figure 7 shows how the contractor's performance measures fit into the strategic management system. The Department's strategic plan establishes a mission, vision, goals, strategies, and levels of success. The plan shows the objectives, identifies strategic goals, and indicates how to achieve those goals. It is also the foundation for program, field element and contractor strategic, operational, and institutional plans. Strategic planning and performance measurement provide a solid basis for results-oriented resource allocations.

17. Occupational safety personnel must demonstrate a working level knowledge of the development and management of both the technical and programmatic elements of an occupational safety program.

- a. Discuss the function and typical content of a safety program that meets 10 CFR 851 and OSHA and applies Integrated Safety Management and compare these to DOE-OSHA VPP.**

10 CFR 851

The following is taken from 10 CFR 851.11.

Each contractor must

- establish and maintain a worker safety and health program for the workplaces for which the contractor is responsible;
- coordinate with the other contractors responsible for work at the covered workplaces to ensure that there are clear roles, responsibilities, and procedures to ensure the safety and health of workers at multi-contractor workplaces.

The worker safety and health program must describe how the contractor will

- comply with the requirements that are applicable to the covered workplace, including the methods for implementing those requirements;
- integrate the requirements that are applicable to a covered workplace with other related site-specific worker protection activities and with the ISMS.

The following is taken from the U.S. Department of Labor, Occupational Safety and Health Administration, Sample Safety and Health Program for Small Business.

This sample program follows the OSHA Safety and Health Program Management Guidelines, published on January 26, 1989 in the Federal Register. These guidelines were drawn from the experience obtained enforcing the OSHA Act, from the VPPs, OSHA programs to recognize excellence in worksite safety and health, from OSHA's consultation program, and from public commentary. This sample program is especially written for the small, independent business owner, but the outline can be applied to any size business.

This management system contains four basic program elements:

1. Management leadership and employee involvement
2. Worksite analysis
3. Hazard prevention and control
4. Training

Under each element are numerous sub-elements. This program contains descriptions of how the program elements and sub-elements are designed and implemented.

Management Leadership and Employee Involvement

Management commits the necessary resources of staff, money, and time to ensure that all persons on the worksite are protected from injury and illness hazards. In addition, management visibly leads in the design, implementation, and continuous improvement of the site's safety and health activities. Specifically, the highest level management establishes and reviews annually the site's safety and health policy and ensures that all employees know, understand, and support that policy. All management levels, with input from hourly employees, develop an annual safety and health goal with objectives and action plans to reach that goal. At the end of each year all management levels, with input from hourly employees, evaluate progress in accomplishing the action plans, achieving all objectives, and meeting the annual goal. This evaluation, which also includes an evaluation of the overall safety and health program, results in a written report that includes the next year's goal, objectives, and action plans, including any remaining action needed to accomplish the current year's goal.

Management ensures that all employees, including themselves, have clearly written safety and health responsibilities included within their job description, with appropriate authority to carry out those responsibilities. Also, management ensures that all employees, including all levels of management, receive performance evaluations that include a written evaluation of the accomplishment of assigned safety and health responsibilities.

Management ensures that all visitors to the site, including contract and temporary labor, co-op students, interns, vendors, and sales people, have knowledge of site hazards applicable to them and how to protect themselves against those hazards, including

emergency alarms and procedures. Management also ensures that these visitors do not introduce to the site hazards that can be prevented or that are not properly controlled.

Management ensures that at least several avenues exist for employee involvement in safety and health decision-making and problem solving. These avenues may include serving on committees and ad hoc problem-solving groups, acting as safety observers, assisting in training other employees, analyzing hazards inherent in site jobs and how to protect against those hazards, and planning activities to heighten safety and health awareness. Management encourages employees' involvement and devises appropriate recognition for outstanding employee participation.

Worksite Analysis

Management hires outside consultants as necessary to conduct baseline surveys that identify all safety and health hazards at the site at the time of the survey. All hazards found during these surveys are eliminated whenever possible or controlled. All employees who may encounter the controlled hazards are trained in appropriate job procedures to follow to protect themselves from these hazards.

Management establishes change procedures to follow whenever the site experiences changes in equipment, material, or processes. To ensure employee protection, these change procedures include consideration of safety and health in the selection of the change, equipment, and process shut-down procedures, start-up procedures, and phase hazard analysis. Appropriate employees are trained to follow these procedures.

Management and employees work together to analyze safety and health hazards inherent in each jobsite and to find means to eliminate those hazards whenever possible, and otherwise to protect persons against those hazards. The JHAs are revised as appropriate, for example, following a change in the job, the reappearance of a hazard, or an accident at the job.

All employees at this sample site are trained to recognize hazards and to report any hazard they find to the appropriate person so that the hazard can be corrected as soon as possible. In addition to taking immediate action to report a hazard orally and to provide interim protection, if necessary, including stopping the work causing the hazard, employees may submit a safety work order to the maintenance department, or they may submit a safety suggestion form. Safety work orders take priority over any other work order. Safety suggestions will be considered each week during the site inspection by the site inspection team. All employee reports of hazards must be eventually written, with the correction date recorded. These reports are posted in the lunch room until the hazard is corrected and then are kept on file in the owner's office for three years. During that time they are available for employee review.

Site management, with input from an hourly employee chosen by lot, organizes the monthly site inspection team. Membership on these teams rotates each month with the goal that all site employees serve one month each year. Teams consist of four people, two managers or supervisors and two hourly employees. Each week, at the beginning of work on Wednesday morning, the team inspects the entire worksite, in writing describing all hazards found, including their location. The team assigns appropriate persons responsible for seeing that the hazard is corrected and documenting the date of the correction. These

inspection reports are posted in the lunch room, in the maintenance shop, and in the owner's office. A hazard remains on the monthly report until it is corrected.

Any near miss, first aid incident, or accident is investigated by the trained team selected each year by the owner and an hourly employee. The team consists of two managers or supervisors and two hourly employees, each of whom has received training in accident investigation. All investigations have as a goal the identification of the root cause of the accident, rather than assigning blame. All accident reports are posted in the lunch room and are open to comment by any employee. The accident investigation team assigns responsibility to appropriate employees for correcting any hazards found and for assigning a date by which the correction must be completed.

As part of the annual safety and health program evaluation, the site owner, a manager, and an hourly employee review all near misses, first aid incidents, and entries on the OSHA 300 log, as well as employee reports of hazards, to determine if any pattern exists that can be addressed. The results of this analysis are considered in setting the goal, objectives, and action plans for the next year.

Hazard Prevention and Control

Management ensures this priority is followed to protect persons at this site: 1) hazards will be eliminated when economically feasible, such as replacing a more hazardous chemical with a less hazardous one; 2) barriers will protect persons from the hazard, such as machine guards and PPE; 3) exposure to hazards will be controlled through administrative procedures, such as more frequent breaks and job rotation.

Management ensures that the worksite and all machinery is cared for properly so that the environment remains safe and healthy. If maintenance needs exceed the capability of the worksite employees, contract employees are hired to do the work and are screened and supervised to ensure they work according to the site's safety and health procedures.

All employees, including all levels of management, are held accountable for obeying site safety and health rules. The following four-step disciplinary policy will be applied to everyone by the appropriate level of supervisor:

1. Oral warning
2. Written reprimand
3. Three day's away from work
4. Dismissal

Visitors, including contractors who violate safety and health rules and procedures, will be escorted from the site. Should the disciplined person request a review of the disciplinary action, an ad hoc committee of six people, three managers and three hourly workers, chosen by their respective colleagues, will review the situation and make a recommendation to the owner, who reserves the right for final decision. If his decision differs from the committee, he may, within confidentially strictures, make public his reasons.

The site works with appropriate outside agencies, such as the fire department, the police department, and the hospital to write emergency plans for all potential emergencies, including fire, explosion, accident, severe weather, loss of power and/or water, and violence from an outside source. Desk-top drills are conducted monthly so that all

employees experience a drill on each type of emergency once a year. A total site evacuation drill focusing on one emergency type, with all work shut down, and coordinated with the appropriate agency, is conducted once a year. Each drill, whether table-top or actual evacuation, is evaluated by the drill planning committee, constituted each year with two managers or supervisors and two hourly employees who volunteer. This committee's written report is posted in the lunch room, and supervisors ensure that all employees know the results. When necessary, the emergency procedures are revised as a result of the evaluation report.

Persons needing emergency care are transported by company van or community ambulance to the hospital, located five miles from the site. Usually that trip can be made in less than ten minutes. Onsite during all shifts designated persons fully trained in CPR first aid, and the requirements of OSHA's bloodborne pathogen standard, are the first responders to any emergency. These persons are trained by qualified Red Cross instructors. One of these designated persons' safety and health responsibilities is to ensure that first-aid kits are stocked and readily accessible in the marked locations throughout the plant. Appropriate PPE is provided for the different types of accidents possible at the site. All emergency responders have been offered the hepatitis B vaccine.

Management maintains a proactive occupational health program that provides for occupational health professionals from the local hospital to participate in worksite analyses to find and protect employees against all health hazards. This plan provides initial health screening for each employee, appropriate to the hazards with which each employee will be working, and for tracking of any health changes in each employee through periodic physical examinations, post-exposure exams, and exit exam. Certified industrial hygienists conduct periodic air and noise monitoring.

The doctor and occupational health nurse, working on contract for the site, examine health surveillance data to discern changes in overall employee health screening results to discern any trends that need to be addressed. Health professionals, appropriately trained and knowledgeable about site hazards, immediately treat employees for occupational health problems and follow each case until the individual can return full-time to all aspects of the assigned job. These professionals ensure that employee medical records are kept confidentially so that diagnosis and treatment are not divulged, but management does have information about the employee under treatment as to

- ability to perform job tasks
- job limitations or accommodations needed
- length of time the limitations must be implemented

Management ensures that supervisors honor these restrictions. This health care is provided free of charge for all employees. The total plan is reviewed annually to assess its effectiveness.

Through consultants, management has assessed all work at this site and determined that the following OSHA standards apply to the site's work. Individual safety and health programs for each of these standards have been written and implemented. Employees affected by these standards have been trained to understand them and to follow the programs' directions.

Training

Management believes that employee involvement in the site's safety and health program can only be successful when everyone on the site receives sufficient training to understand what their safety and health responsibilities and opportunities are and how to fulfill them. Therefore, training is a high priority to ensure a safe and healthy workplace. Finding time and knowledgeable personnel to do effective training is vital. Each year management pays special attention to the evaluation of the year's training efforts to look for methods of improvement.

Currently, all new employees receive two hours of safety and health orientation before they begin work. When they have learned this material, they begin their assigned job with a trained buddy. For the first day the employee only observes the buddy doing the job and reads the appropriate JHAs. The second day the new employee does the job, while the buddy observes him/her. For the first six months on the job a new employee is considered a probationer and may not work beyond the line of vision of another employee. Supervisors are strictly charged to ensure that this training process is followed for all new employees and for any employee beginning a new job at the worksite.

All employees are paid for one full day's work (eight hours) beyond their production schedule each pay period. This time is usually split into several sections to attend training classes. A list of training topics, by week, is published each year. Each topic is offered at least twice. Each employee is responsible for ensuring that he/she masters the year's training topics. Completing the year's training is a significant portion of each employee's performance evaluation, including all levels of management. Training records are kept by the personnel manager and are available for employee review, upon request.

All employees are encouraged to suggest qualified trainers, including themselves. Management is responsible for ensuring that all training offered at the site is conducted by qualified persons.

b. Discuss general principles of management applicable to the organization of the safety function, safety program planning, safety program evaluation, and communications with labor, management, and the public.

Safety Function

The following is taken from Federal Assurance Capability Plan Inspection, Criteria and Approach, DNFSB 2004- 1, Commitment 16.

Section 5.1.1 of the DOE Implementation Plan to Improve Nuclear Operations, Revision 2 states that the CTAs are line management executives who will be responsible for the following core nuclear safety functions for their organizations and facilities:

- Concurs with the determination of the applicability of DOE directives involving nuclear safety included in contracts pursuant to DEAR 970.5204-2.
- Concurs with nuclear safety requirements included in contracts pursuant to DEAR 970.5204.
- Concurs with all exemptions to nuclear safety requirements in contracts that were added to the contract pursuant to DEAR 970.5204-2.
- Recommends to the Chief Health, Safety and Security Officer issues and proposed resolutions concerning DOE safety requirements, concurs in the adoption or revision of nuclear safety requirements, and provides expectations

and guidance for implementing nuclear safety requirements as necessary for use by DOE employees and contractors.

- Maintains operational awareness of the implementation of nuclear safety.
- Periodically reviews and assesses whether DOE is maintaining adequate numbers of technically competent personnel necessary to fulfill nuclear safety responsibilities.
- Provides inputs to, reviews, and concurs with DOE-wide nuclear safety-related research and development activities.

The following is taken from DOE O 440.1B.

General principles of management applicable to safety-related elements are listed below:

- Ensure through the contracting officer that contractors implement the requirements of 10 CFR 851.
- Review contractor worker protection program budgets and provide recommendations to the funding official on the appropriateness of the budget request.
- Provide contractors with technical direction on and criteria for the development of contractor goals, objectives, and performance measures.
- Hold DOE line personnel accountable for providing technical direction to contractors that is consistent with the requirements contained in 10 CFR 851.
- Evaluate the need for and direct the development of formal written agreements outlining the respective roles, responsibilities, and authorities of each departmental element as they relate to compliance with DOE worker protection requirements and the resolution of cross-cutting worker protection-related issues.
- Review and forward to the DOE Chief Health, Safety and Security Officer all exemptions, exceptions, and variances to mandatory work protection requirements contained in DOE O 440.1B. Conduct an annual review of the status of all exemptions to the requirements contained in DOE O 440.1B to ensure that circumstances requiring the need for relief have not changed and that instituted controls are still implemented and appropriate.
- Provide annually to the HSS input for the DOL's FEOSH report, including status of progress in meeting established goals, new initiatives, and other requested information.
- Establish annually FEOSH program goals and objectives for both promoting the program and for reducing accidents, injuries, and lost-time cases.

c. Describe the role and significance of the following major elements in a successful safety program:

- **Positive management leadership**
- **Assignment of safety management roles, authorities, accountabilities, and responsibilities**
- **Formal statement of policy**
- **Maintenance of safe working conditions**
- **Establishment of control and prevention programs**
- **Worksite analysis**
- **Training**
- **Employee involvement**
- **Program and work area assessments.**

Positive Management Leadership

The following is taken from OSHA, Safety & Health Management Systems e-Tool, *Fact Sheets—Management Leadership*.

Management demonstrates leadership by providing the resources, motivation, priorities, and accountability for ensuring the safety and health of its workforce. This leadership involves setting up systems to ensure continuous improvement and maintaining a health and safety focus while attending to production concerns. Enlightened managers understand the value in creating and fostering a strong safety culture within their organization. Safety should become elevated so that it is a value of the organization as opposed to something that must be done or accomplished. Integrating safety and health concerns into the everyday management of the organization, just like production, quality control, and marketing, allows for a proactive approach to accident prevention and demonstrates the importance of working safely into the entire organization.

Assignment of Safety Management Roles, Authorities, Accountabilities, and Responsibilities

The following is taken from OSHA, Safety & Health Management Systems e-Tool, *Fact Sheets—Management Leadership*.

Everyone in the workplace should have some responsibility for safety and health. Clear assignment helps avoid overlaps or gaps in accomplishing activities. Safety and health is not the sole responsibility of the safety and health professional. Any realistic assignment of responsibility must be accompanied by the needed authority and by having adequate resources. This includes appropriately trained and equipped personnel as well as sufficient operational and capital funding.

Accountability is crucial to helping managers, supervisors, and employees understand that they are responsible for their own performance. Reward progress and enforce negative consequences when appropriate. Supervisors are motivated to do their best when management measures their performance—“what gets measured is what gets done.” Take care to ensure that measures accurately depict accomplishments and do not encourage negative behaviors such as not reporting accidents or near misses. Accountability can be established in safety through a variety of methods:

- Charge accident costs back to the department or job, or prorate insurance premiums.
- Set safety goals for management and supervision.
- Conduct safety activities to achieve goals.

The following is taken from OSHA, Safety & Health Management Systems e-Tool, *Responsibility, Authority and Accountability*.

When you have authority or responsibility, your performance is not necessarily measured. But when you are held accountable, your performance is measured in relation to standards or goals that result in certain positive or negative consequences.

An owner or top manager of a business delegates certain responsibilities to other worksite managers or supervisors. The owner must avoid undercutting the authority of the managers, since that will interfere with their ability to carry out those responsibilities. At

the same time, the owner wants to demonstrate their own commitment to reducing safety and health hazards and protecting employees. How can this be done?

Elements of an Effective Accountability System

Any accountability system should have the following elements to be effective:

- Established standards in the form of company policies, procedures or rules that clearly convey standards of performance in safety and health to employees
- Resources needed to meet the standards, such as a safe and healthful workplace, effective training, and adequate oversight of work operations
- A measurement system that specifies acceptable performance
- Consequences, both positive and negative
- Application at all levels

When managers and employees are held accountable for their safety and health responsibilities, they are more likely to press for solutions to safety and health problems than to present barriers. By implementing an accountability system, positive involvement in the safety and health program is created.

Formal Statement of Policy

Developing a clear statement of management policy, helps everyone involved with the worksite understand the importance of safety and health protection in relation to other organizational values (e.g., production vs. safety and health). A safety and health policy provides an overall direction or vision while setting a framework from which specific goals and objectives can be developed. Make the general safety and health policy specific by establishing clear goals and objectives. Make objectives realistic and attainable, aiming at specific areas of performance that can be measured or verified.

Maintenance of Safe Working Conditions

The following is taken from DOE—The Federal Employee Occupational Safety and Health (FEOSH) Program Overview.

Each supervisor is responsible for maintaining safe working conditions within his or her area of responsibility and directly implementing the FEOSH program. The following are among the supervisor's primary responsibilities:

- Participate in and encourage workers to participate in the FEOSH program, including making use of all safety and health resources and personnel.
- Consult with safety, IH, engineering, and medical personnel for aid in fulfilling FEOSH duties.
- Maintain a safe work environment for employees, including stopping work (if necessary) or providing interim protection for workers while hazards are being abated.
- Instruct employees periodically on precautions, procedures, and practices to be followed to minimize exposure to hazardous conditions or harmful agents.
- Ensure that appropriate work practices are developed and followed, including good housekeeping practices and rules for work with hazardous materials.
- Furnish employees with proper PPE, instructing them in its proper use, and enforcing its use.

- Promptly inform the medical provider in case of accidental exposure to harmful agents, and send the employee(s) involved to the medical provider for examination.
- Observe all work restrictions imposed by the medical provider.
- Administer appropriate disciplinary action when health and safety rules are violated.

Establishment of Control and Prevention Programs

The following is taken from the Oklahoma Department of Labor, Essential Elements of an Effective Safety & Health Program.

In designing the prevention and control program, the ideal situation would be to eliminate hazards or exposures that employees would encounter. Since this is not always possible, employers should use the best available methods for protecting employees. Engineering controls combined with good work practices can, for the most part, provide maximum protection for employees. The employer is responsible for providing whatever training is necessary to ensure that their employees know how to use the systems in place for protection. So that all current and potential hazards, however detected, are eliminated or controlled in a timely manner, establish procedures for that purpose using the following measures:

- Engineering techniques where feasible and appropriate
- Procedures for safe work which are understood and followed by all affected parties, as a result of training, positive reinforcement, correction of unsafe performance, and, if necessary, enforcement through a clearly communicated disciplinary system
- Provision of PPE
- Administrative controls, such as reducing the duration of exposure

Methods of preventive maintenance include the following:

- Provide for facility and equipment maintenance, so that hazardous breakdown is prevented.
- Plan and prepare for emergencies, and conduct training drills as needed, so that the response of all parties to emergencies will be “second nature.”
- Establish a medical program which uses occupational health professionals in the analysis of hazards, early recognition and treatment of illness and injury, and limitation of the severity of harm; and which provides first aid and CPR onsite and physician and emergency medical care nearby, so that harm will be minimized if an injury or illness does occur.

Worksite Analysis

The following is taken from OSHA, Safety & Health Management Systems e-Tool, Worksite Analysis.

Worksite analysis involves a variety of worksite examinations to identify not only existing hazards, but also conditions and operations in which changes might create hazards. Effective management actively analyzes the work and the worksite, to anticipate and prevent harmful occurrences.

Here's a suggested plan to identify all worksite hazards:



- Conduct a comprehensive, baseline survey for safety and health and periodic, comprehensive update surveys.
- Change analysis of planned and new facilities, processes, materials, and equipment.
- Perform routine job hazard analyses.
- Conduct periodic and daily safety and health inspections of the workplace.

Training

The following is taken from OSHA, Safety & Health Management Systems e-Tool, Fact Sheets—Safety and Health Training.

New employees need to be trained not only to do the job, but also to recognize, understand, and avoid potential hazards to themselves and others in their immediate work area and elsewhere in the workplace. Contract workers also need training to recognize workplace's hazards or potential hazards. Experienced workers will need training if new equipment is installed or process changes. Employees needing to wear PPE and persons working in high risk situations will need special training. Some worksites need complex work practices to control hazards. Some worksites experience fairly frequent occupational injuries and illnesses. At such sites, it is especially important that employees receive periodic safety and health training to refresh their memories and to teach new methods of control. New training also may be necessary when OSHA or industry standards require it or new standards are issued.

One-on-one training is possibly the most effective training method. The supervisor periodically spends some time watching an individual employee work. Then the supervisor meets with the employee to discuss safe work practices, bestow credit for safe work, and provide additional instruction to counteract any observed unsafe practices. One-on-one training is most effective when applied to all employees under supervision and not just those with whom there appears to be a problem. Positive feedback given for safe work practices is a very powerful tool. It helps workers establish new safe behavior patterns and recognizes and thereby reinforces the desired behavior.

Employee Involvement

The following is taken from OSHA, Safety & Health Management Systems e-Tool, Fact Sheets—Employee Involvement.

The best worker safety and health protection occurs when everyone at the worksite shares responsibility for protection. Basic principles of excellence have shown that wise employers use employees' unique knowledge to help find problems and resolve them. In addition, no one else has as much at stake to avoid accidents as the employees who are likely to be injured. The more employees are involved in a variety of safety-related activities, they will appreciate the potential hazards that exist at the worksite, and be more likely to avoid unsafe behaviors; and the overall safety culture of the organization will strengthen. Without employees' involvement and cooperation, accidents are difficult to prevent. What are the advantages of getting employees involved?

- Employees are the ones in contact with potential hazards and will have a vested interest.
- Group decisions have the advantage of the group's wider field of experience.
- Research shows that employees are more likely to support and use programs in which they have had input; employee buy-in for the needed changes is more likely.
- Employees who are encouraged to offer their ideas and whose contributions are taken seriously are more satisfied and productive.
- The more that employees are involved in the various facets of the program, the more they will learn about safety, what is causing injuries at their site, and how they can avoid being injured. The more they know and understand, the greater their awareness will be and the stronger the safety culture of the organization will become.

How can employees get involved?

- Participate on joint labor-management committees and other advisory groups.
- Conduct site inspections.
- Analyze routine hazards in each step of a job or process, and prepare safe work practices.
- Participate in developing and revising safety rules.
- Participate as trainers for current and new hires.
- Participate in accident/near miss incident investigations.
- Participate in decision-making throughout the company's operations.
- Participate in pre-use and change analysis.
- Participate as safety observers and safety coaches.
- Report hazards and be involved in finding solutions to correct the problems.

Program and Work Area Assessments

The following is taken from DOE G 450.4-1B.

The feedback and improvement safety function is directly dependent on the effectiveness of assessments. To effectively accomplish the objectives of an assessment program, the assessment process needs to do more than develop a list of deficiencies. The process must produce a robust, rigorous, and credible assessment that is acceptable to DOE and the contractor. The results can be used with confidence to accomplish the following:

- Identify areas that do not meet the requirements. These departures from requirements are generally called "deficiencies" or "findings." Coincident with identifying problems, specific strengths, and successes may be discovered that may be worthy of identification.

- Prioritize those problems identified using a prioritization system based upon each problem's importance in the execution of ISMS policies. Such priority classification can be assigned by the assessor or the manager responsible for the expenditure of resources and program execution in the work area assessed or by both.
- Correct problems and follow up to help ensure that the problems assessed and prioritized for correction have in fact been corrected, and that the correction has been effective enough to result in sustained, long-term improvement for generic problems. Deficiencies or potential problem areas (e.g., from "lessons learned") would generally result in a "watch list" of items for follow-up assessments.

d. Describe the importance of and methods for establishing, updating, and measuring program performance against safety program goals and objectives.

The following is taken from DOE M 450.4-1.

The purpose of safety performance objectives, measures, and commitments is to drive improvement in safety performance and ISMS effectiveness.

Performance objectives can be long-term management system goals or specific management objectives or deficiencies that need to be addressed. They may be driven by strategic planning processes or safety goals processes. Performance objectives are expected to remain relatively unchanged over multiple years, with a bias toward continuously rising standards of performance. Improving performance is expected over the long term.

Performance commitments are specific actions that will be taken during a specific year to further achievement of long-term performance objectives. Commitments are steps that will be funded to move toward accomplishment of the performance objectives.

Performance commitments would be expected to address significant identified weaknesses or areas of improvement. These may include either major corrective actions or major improvement actions.

Performance measures are used to track progress and monitor achievement of performance objectives and commitments. The most useful performance measures provide information that directly reflects how safely the operational work is being performed. A combination of leading and lagging indicators is desirable. The measures are changed as necessary to address the performance objectives, and significant identified weaknesses and areas for improvement. Annual performance expectations should be established for most of these measures.

Performance objectives, measures, and commitments are developed based on numerous considerations including the budget process. This approach to continuous improvement recognizes the need for investment in improvement. The ISM guiding principle, "balanced priorities," must be considered in developing appropriate performance objectives, measures, and commitments.

Secretarial office ISMS descriptions should describe how ISM performance is measured and may provide a standard set of ISM performance indicators. This should be included

in the section on ISMS performance objectives, measures, and commitments, and should be updated annually.

The following are sample topic areas for consideration as DOE performance objectives, measures, and commitments if problems exist or if emphasis needs to be placed; this list should not be considered all-inclusive or mandatory:

- Integrated safety management system effectiveness
- Management systems
- Regulatory performance
- Quality assurance
- Safety culture
- Authorization bases
- Stakeholder relations
- Operational performance
- Environmental protection
- Waste management
- Emergency preparedness
- Safeguards and security
- Fire protection
- Transportation management
- Near-misses
- Work planning and control
- Feedback and improvement
- Effectiveness reviews of completed corrective actions
- Safety issue reporting
- Management walkthrough program
- Assessment and oversight program
- Self-assessment
- Vital safety system assessments
- Clear roles and responsibilities
- Human resource management
- Employee training and development
- Minority/differing professional opinion
- Subcontractor safety performance
- Electrical safety
- Criticality safety
- Nuclear safety basis document updates
- Project controls and baseline management
- Project management
- Workforce management
- Occupational safety and health (industrial safety and health)
- Radiological safety
- Infrastructure and facility management
- Systems and equipment essential to safety
- Construction management
- Decontamination and decommissioning
- Maintenance
- Configuration management
- Environmental restoration

- Risk reduction
- Pollution prevention/sustainable environmental stewardship
- National ambient air quality standards attainment
- Watershed approach for surface water protection
- Site-wide approach for groundwater protection
- Protection of natural resources
- Protection of cultural resources

The following are sample performance objectives:

- Achieve zero organizational accidents.
- Perform work so that personnel hazards are anticipated, identified, evaluated, and controlled.
- Perform work in a manner that does not present a threat of harm to the public or the environment and will identify, control, and respond to environmental hazards.
- Be recognized for operational excellence.
- Be recognized for excellent personnel.
- Be recognized for excellent safety culture.
- Be recognized for sound environmental management practices.
- Senior leadership commitment to safety is clear and visible.
- Establish and sustain a robust safety culture, consistent with ISM principles.
- Fully integrate HPI initiatives into ISM systems.
- Demonstrate sound stewardship of the site through safe and effective hazardous and radioactive waste minimization and management through restoration of the site where degradation has occurred.

e. Identify common safety program performance indicators.

The following is taken from DOE M 450.4-1.

The following are sample performance measures:

- Exposures of personnel to chemical, physical, and biological hazards are adequately controlled.
- Accident and injury rates, lost workday case rates, and the DOE injury cost index are adequately controlled.
- Exposures of personnel to ionizing radiation are adequately controlled.
- ORPS-reportable occurrences, intakes of radioactivity, and skin contaminations are managed and minimized.
- Radioactive material is adequately controlled.
- The fire department response time and the rate of completion of required fire protection is adequately controlled and accomplished.
- Environmental violations and releases are adequately controlled.
- Reduce the amount of waste generated and the amount of pollutants emitted.
- Manage hazardous and radioactive wastes in a manner that meets regulatory requirements and is cost effective.
- Identify and control the number of error-likely situations.
- Behavioral and process measures—such as the number of near-misses, the number of error reports, the number of behavioral observations, the number of safe acts, etc.
- Events—first aid cases, occurrences, near misses.
- Safety inspections—number and score.

- Employee input—safety concerns and survey responses.
- Management assessment results.
- Housekeeping inspection results.
- Safety related work package cycle time.
- Procedure compliance rates.
- Corrective actions are timely.
- Corrective actions are effective at resolving originally-identified causes.
- The number of repeat occurrences is minimized through effective corrective actions.
- Employee concerns are tracked and resolved in a timely manner.
- Employee concerns are effectively addressed to resolve the identified concerns.
- Self-assessments effectively identify issues raised by independent organizations when systemic issues are identified.
- The quality of safety basis documents, as measured by defects identified by assessments or occurrences, is excellent.
- Issue assessment and oversight schedule by September 30th of each year.
- Complete 95 percent or greater of annually planned assessments.
- Complete 90 percent or greater of identified employee qualifications on time.
- Implement line manager walk-around program such that line managers spend at least 100 hours individually in the field each year.
- Define work scope priorities and communicate them to contractors by July 31st of each year to guide annual work planning.
- Review corrective actions monthly with the contractor for any cost or schedule variance that is greater than a negative ten percent.
- Conduct monthly all-employees meeting with an emphasis on safety.
- Implement differing professional opinion procedure and train employees.
- Environmental compliance performance improvement and pollution prevention performance improvement.

The following are sample performance commitments:

- Develop performance evaluation standards to ensure greater line management responsibility and accountability for safety.
- Develop and implement processes for work planning and control that fulfill the attributes of best practice processes.
- Develop a robust and comprehensive line organization self-assessment program to assess overall safety performance and ISM effectiveness.
- Achieve pollution prevention and sustainable environmental stewardship goals set forth in DOE O 450.1A, *Environmental Protection Program*.
- Implement DOE ISM supplemental safety culture elements.
- Initiate two HPI projects.
- Achieve pollution prevention and sustainable environmental stewardship goals set forth in DOE O 450.1A.
- Train employees on ISMS revisions.
- Conduct two safety system assessments.
- Maintain VPP STAR status.
- Improve total recordable case rate by implementing the DuPont safety training and observation program (STOP).
- Achieve pollution prevention and sustainable environmental stewardship goals set forth in DOE O 450.1A.

f. Discuss safety program funding and human resource issues that must be considered in both short and long term plans and budgets.

Safety Program Funding

The following is taken from 29 CFR 1960.6 and 29 CFR 1960.7.

The head of each agency shall designate an official with sufficient authority and responsibility to represent effectively the interest and support of the agency head in the management and administration of OSH. The head of each agency shall ensure that the agency budget submission includes appropriate financial and other resources to effectively implement and administer the agency's OSH program.

The following is taken from DOE Order 3790.1B (archived).

Heads of field elements with delegated personnel authority must establish and maintain FEOSH programs that meet the requirements of section 19 of the Occupational Safety and Health Act of 1970, EO 12196, 29 CFR 1960, and amplifying DOE directives. In discharging these responsibilities, they shall

- designate an official with sufficient authority and responsibility to plan for and assure funds for necessary safety and health staff, equipment, materials, and training required to manage and administer the FEOSH Program; and
- ensure that funds sufficient to conduct the program are identified in the budget planning process.

Human Resource Issues

The following is taken from the DOE Guide to Workforce Planning.

The vast majority of an organization's improvement comes when the right people with the right knowledge, skills, and behaviors are deployed appropriately throughout an organization. Workforce planning is about how to achieve that match of skills, knowledge, and behaviors. It is about

- developing an understanding of everything possible about the internal and external environment and how those factors will affect the current and future workforce;
- understanding the makeup of the current workforce and the necessary skills, capabilities, and aptitudes that will be required to achieve business outcomes in the current and changing environment; and
- ensuring human resources strategies are linked with business outcomes and ensuring that workforce plans reflect those initiatives/strategies and provide managers with a framework for making informed decisions in line with the mission, strategic plan, and financial resources.

Also, it provides the opportunity for longer-term thinking about future service pressures and needs, and what is necessary now to get workable strategies in place—not only for employee development, but for strategic financial and human capital management.

The DOE Guide to Workforce Planning provides supporting information that will help align human resources processes to create short- and long-term solutions for current and future human capital issues and provide a means of integrating and giving meaning to many areas of human resources initiatives that are at times overlooked.

There is no one set model of workforce planning, but the underlying concepts are similar. All models are concerned about analyzing the current workforce and then extending that analysis to identify the future skills and competencies needed to deliver new and improved services that are aligned with achieving the Department's mission. The comparison between the present workforce and the desired future workforce will highlight the shortages, surpluses, and competency gaps, whether due to external pressure or internal factors. These gaps become the focus of each detailed workforce plan in identifying and implementing strategies that will build the relevant skills and capability needed for organizational success.

g. Discuss the importance of employee participation in the implementation of the safety programs and identify potential methods to ensure or encourage involvement.

The following is taken from OSHA, Course 700: Introduction to Safety Management, Module Three: Employee Involvement.

It is difficult to have an effective safety and health program without developing a corporate safety culture that encourages genuine employee involvement. Safety rewards come in many colors, flavors, and varieties. We are all motivated by primarily two types of rewards: extrinsic and intrinsic. Extrinsic rewards are tangible and external. You can touch, eat, see, smell, or otherwise use them. On the other hand, intrinsic rewards are intangible, internal, and housed within us.

More and more companies are discovering that the most effective safety recognition programs are primarily proactive. Proactive recognition programs reward employee behaviors that are 1) mandated by the employer and/or OSHA regulations, and 2) encouraged but not required. All these behaviors proactively actually prevent or minimize the negative impact of injuries and illnesses in the workplace.

Proactive recognition programs that work:

- Safety Buck: Supervisors carry safety bucks, and when they see someone doing something right, they reward them. The employee can take the safety buck to the company cafeteria for lunch, or they can use it at a local participating store to purchase items.
- Bonus Program: When an employee identifies a hazard in the workplace that could cause serious physical harm or a fatality, they are rewarded with a bonus check. In some cases the bonus check is a fixed amount. In other programs the bonus check is a small percentage of the potential direct cost for the accident that might have occurred. The average direct cost for a disabling claim is around \$10,000. Doesn't it make sense to reward an individual with \$100 for identifying a hazard that could potentially cost the company thousands?
- Safety Hero: After an extended period of time, employees are rewarded with a certificate or bonus check for complying with company safety rules.
- Reporting Injuries: If employees report injuries immediately, they not only minimize the physical/psychological impact of the injury on themselves, they reduce the direct/indirect accident costs to the company. The individual and the company win if the employee reports injuries immediately.

Mandatory Performance Activities:

- h. Participate in a management or employee activity implementing or improving workplace safety such as VPP assessment, local safety committee project, or safety implementation for new work startup.**

This is a performance-based KSA. The Qualifying Official will evaluate its completion.

- 18. Occupational safety personnel must demonstrate a working level knowledge of assessment techniques applicable to evaluating occupational safety, reporting results, hazard mitigation and abatement, and following up on actions taken as the result of assessments.**

- a. Describe oversight roles and responsibilities of Federal and contractor occupational safety personnel for nuclear facilities.**

The following is taken from Memorandum of Understanding Between the U.S. Department of Labor and the U.S. Department of Energy.

The purpose of this MOU between the DOL and the DOE is to evaluate the possible transition from internal DOE oversight of occupational safety and health matters involving private-sector employees at DOE GOCO facilities to external enforcement by OSHA. This MOU identifies a specific project to be carried out in accordance with the terms of the August 10, 1992, DOL/DOE MOU.

The OSH Act of 1970 (P.L. 91-596) grants OSHA the authority to prescribe and enforce standards or regulations affecting the occupational safety and health of private-sector employees. However, section 4(b)(1) of the Act waives OSHA's jurisdiction in cases where another Federal agency has exercised its statutory authority to prescribe or enforce occupational safety and health standards. Relying on this section of the Act, DOL, in 1974, explicitly recognized the AEC's authority to establish and enforce occupational safety and health standards at AEC-sponsored contractor facilities. Subsequently, DOL and DOE, the successor agency to the AEC, acknowledged this agreement in the August 10, 1992, MOU between the two departments. As specified in the original agreement and in the 1992 MOU, this DOE exemption from OSHA enforcement has applied only to those GOCO facilities for which DOE exercises its statutory authority pursuant to the Atomic Energy Act of 1954; OSHA has exercised enforcement authority over all other DOE facilities.

In the twenty years that have intervened since the signing of the original 1974 agreement, DOE has exercised its authority over working conditions at its GOCO facilities by developing and promulgating DOE Orders and conducting an extensive program of internal oversight at these facilities. In May 1993, however, Secretary O'Leary announced that DOE would immediately begin the process of shifting from internal oversight of occupational safety and health to external enforcement by OSHA.

DOE and OSHA will work together to explore, identify, and develop strategies to facilitate a seamless transition from internal DOE oversight to external OSHA enforcement of occupational safety and health on DOE GOCO facilities. This cooperative effort will continue to protect the safety and health of DOE contractor workers and will build upon the lessons learned from the recent transfer of the Gaseous Diffusion Plants in

Kentucky and Ohio from DOE oversight to OSHA enforcement. To accomplish these mutual goals, the parties agree with the following:

- The DOE Assistant Secretary for Environment, Safety and Health and the DOL Assistant Secretary for Occupational Safety and Health, or their designee, will conduct quarterly interface meetings to facilitate and coordinate efforts performed under this MOU. The frequency of these meetings may be altered by either party as necessary.
- DOE will provide and appropriately fund training, briefings, site orientation visits, and other opportunities, as appropriate, for OSHA personnel to become familiar with DOE GOCO facilities and operations.
- DOE will assist OSHA in and provide the necessary funding for a task force to study the possible transition to OSHA enforcement. OSHA and DOE will develop and implement a statement of work for the study outlining the goals, objectives, and intended focus of the study as well as the respective contributions of both parties. In the performance of the study, DOE and OSHA will solicit and consider input from stakeholders on all aspects of the proposed transition to OSHA enforcement. DOE input to the study may include, but is not limited to, providing assistance in the following areas:
 - An inventory of DOE facilities and identification of the types of hazards likely to be found at each of these facilities
 - The development of a transition schedule for OSHA if it were to assume enforcement authority over working conditions at DOE GOCO facilities
 - An examination of DOE's current occupational safety and health program and the role that this corporate program could assume if there is a transition to OSHA enforcement
 - Identification and consideration of recent occupational safety and health program improvements within the DOE community such as the establishment of safety and health committees
 - An examination of lessons learned from OSHA special emphasis programs and existing DOE external enforcement activities (e.g., transfer of the gaseous diffusions plants to OSHA enforcement, NRC and EPA enforcement activities; OSHA enforcement of worker protection matters on non-exempt DOE facilities), as well as the future findings of the Advisory Committee on External Regulation of DOE nuclear safety
 - An examination of the worker protection-related roles of other external enforcement activities and clarification of institutional relations between: OSHA and DOE; DOE and M&O contractors; M&O contractors and subcontractors; and between Federal, state and tribal jurisdictions
 - An investigation of the additional resources required by OSHA if it were to assume the transferred regulatory and enforcement authority and of the external costs associated with maintaining regulatory and enforcement authority within DOE.
- Upon completion of the study, appropriate representatives of DOL and DOE will prepare and provide to the Secretary of Labor and the Secretary of Energy, a report that examines advantages and disadvantages of a possible transfer of DOE oversight to OSHA enforcement. Following review of this report by both departments, representatives of DOL and DOE will decide what, if any, additional

action(s) should be considered in further exploring a transition of enforcement responsibility.

b. Discuss the DOE policy and orders for contractor oversight.

The following is taken from DOE O 226.1B.

All applicable DOE organizations must establish and implement an effective oversight program consistent with DOE P 226.1A, *Department of Energy Oversight Policy*, the requirements of DOE O 226.1B, and the applicable attachments, to include the following:

- A comprehensive and rigorous assurance system at all sites implemented by the contractor and Federal organizations (for GOCO sites) that manage or operate DOE sites, facilities, or operations.
- DOE field element line management oversight processes, such as inspections, reviews, surveillances, surveys, operational awareness, and walkthroughs that evaluate programs and management systems and the effectiveness of the site assurance system. DOE field elements must prepare documented program plans and annual schedules for both planned assessments and focus areas for operational oversight.
- DOE headquarters line management oversight processes that are focused primarily on the DOE field elements and also look at contractor activities verification/validation through closure, and lessons learned—management practices that are consistent with the requirements of DOE P 226.1A and DOE O 226.1B.
- DOE O 205.1A, *Department of Energy Cyber Security Management*, maintains long-standing requirements for DOE line organizations to conduct cyber security performance assurance activities that meet the intent of DOE O 226.1B. These activities include site assistance visits, program reviews, compliance reviews, self-assessments, management assessments, analysis of performance measurement criteria, peer reviews, and vulnerability analysis.

For activities and programs at government-owned and government-operated facilities and sites that are not under the cognizance of a DOE field organization, DOE headquarters program offices will establish and implement comparably effective oversight process consistent with the requirements for the contractor assurance system and DOE line management oversight process.

c. Describe the role and performance of fact-finding interviews during an occurrence investigation.

The following is taken from DOE-NE-STD-1004-92.

The objective of investigating and reporting the cause of occurrences is to enable the identification of corrective actions adequate to prevent recurrence and thereby protect the health and safety of the public, the workers, and the environment.

It is important to begin the data collection phase of the root cause process immediately following occurrence identification to ensure that data are not lost. Some methods of gathering information include the conducting of interviews/statements. Interviews must be fact finding and not fault finding. Preparing questions before the interview is essential to ensure that all necessary information is obtained. The causal factor work sheets in

DOE-NE-STD-1004-92, *Root Cause Analysis Guidance Document*, appendix B, can be used as a tool to help gather information.

Interviews should be conducted, preferably in person, with those people who are most familiar with the problem. Individual statements could be obtained if time or the number of personnel involved makes interviewing impractical. Interviews can be documented using any format desired by the interviewer. Consider conducting a walkthrough as part of this interview if time permits.

Although preparing for the interview is important, it should not delay prompt contact with participants and witnesses. The first interview may consist solely of hearing their narrative. A second, more-detailed interview can be arranged, if needed. The interviewer should always consider the interviewee's objectivity and frame of reference.

d. Discuss research and analysis of directive and regulatory requirements that serve as the basis of assessment topics and evaluation criteria.

The following is taken from DOE G 414.1-1B.

Compliance assessments focus on verifying compliance with requirements through the implementation of procedures, and begin with a determination of the contractual and regulatory requirements governing the assessed organization. Assessors should become familiar with requirements and procedures and then verify that requirements flow down to implementing documents such as procedures, whose implementation is in turn verified.

Assessing for compliance alone may not adequately identify higher-level systemic or programmatic problems or determine the effectiveness of the program. For example, an organization may have written procedures that appear to implement the requirements. However, in practice the intent of those requirements may not be fully achieved because of variables such as poorly executed procedures.

e. Explain essential elements of a performance-based assessment, including the lines of inquiry, fact-finding and reporting, including a follow-up closure of assessment.

Investigation

The following is taken from DOE-NE-STD-1004-92.

It is important to begin the data collection phase of the root cause process immediately following occurrence identification to ensure that data are not lost. The investigation process is used to gain an understanding of the occurrence, its causes, and what corrective actions are necessary to prevent recurrence.

Fact Finding

The following is taken from DOE G 414.1-1B.

Performance-based assessment takes a different approach by focusing first on the adequacy of the process that produced a product or service and then the product itself. If problems are found in the product or work processes, then the assessor evaluates the methods and procedures used to implement the applicable requirements. This is done to find the failure that led to the problems.

In performance-based assessment, great emphasis is placed on getting the full story on a problem before coming to a conclusion. If an assessor sees a problem with the execution of a welding process, he or she should determine the extent of the problem. Is it limited to one welder? Is it limited to one process? Can the problem be traced to the qualification program for the welder or to the qualification program for the welding process? Or is there a problem with the weld material itself, indicating an engineering or procurement problem?

In performance-based assessment the assessor's experience and knowledge play an integral part in determining where requirements are satisfied. Therefore, participants in performance-based assessments must be technically competent in the areas they are assessing.

The following is taken from DOE-NE-STD-1004-92.

Once all the data associated with this occurrence have been collected, the data should be verified to ensure accuracy. The investigation may be enhanced if some physical evidence is retained. Establishing a quarantine area, or the tagging and segregation of pieces and material, should be performed for failed equipment or components.

The basic need is to determine the direct, contributing and root causes so that effective corrective actions can be taken that will prevent recurrence. Some areas to be considered when determining what information is needed include

- activities related to the occurrence
- initial or recurring problems
- hardware or software associated with the occurrence
- recent administrative program or equipment changes
- physical environment or circumstances

Some methods of gathering information include conducting interviews and collecting statements. Interviews must be factual. Preparing questions before the interview is essential to ensure that all necessary information is obtained. Interviews should be conducted, preferably in person, with those people who are most familiar with the system. Individual statements could be obtained if time or the number of personnel involved makes interviewing impractical. Interviews can be documented using any format desired by the interviewer.

Consider conducting a walkthrough of the system or facility as part of the interview if time permits.

Reporting

Assessment reports are required for documentation of assessment results. Assessment team leaders have the overall responsibility for preparing the report and obtaining appropriate approval for its release as applicable. The report may be formal or informal, depending on the level of assessment performed, but should provide a clear picture of the results in terms of the programs, systems, and processes assessed. The assessment report should be clear, concise, accurate, and easy to understand, and should include only facts that directly relate to assessment observations and results. It should include sufficient information to enable the assessed organization to develop and implement appropriate

improvement plans. Specific report formats may vary considerably from one organization to the next. An independent assessment report usually includes the following sections:

- Executive summary
- Assessment scope
- Identification of team members
- Identification of personnel contacted
- Documents reviewed
- Work performance observed
- Assessment process and criteria
- Results of the assessment including identification of areas for improvement
- Strengths

Exit Interview

The following is taken from DOE G 414.1-1B.

While team leaders have overall responsibility for the report, the entire assessment team should have an opportunity to read and sign the completed report. At a minimum, the final report should be distributed to the management of both the assessed and assessing organizations. Distribution to other organizations should be defined during the planning phase and communicated in advance to the assessed group.

Because the true value of an assessment is the improvement opportunities it identifies, and its value typically diminishes over time, the best time to release a report is immediately after the post-assessment meeting, which allows the assessed organization to begin improvement actions, yielding the maximum return for those actions. The assessment report or transmittal correspondence should clearly indicate what response is expected from the assessed organization and a reasonable response date.

Follow-up

The following is taken from DOE G 414.1-1B.

A follow-up assessment with special focus may be performed and should be completed in accordance with applicable corrective action documents. Particularly, this follow-up assessment should evaluate the effectiveness of corrective actions. A reasonable subset of corrective actions should be reviewed for effectiveness.

f. Describe the typical content and format of an assessment report addressing occupational safety.

The following is taken from DOE G 414.1-1B.

Assessment reports are required for documentation of assessment results. Assessment team leaders have the overall responsibility for preparing the report and obtaining appropriate approval for its release as applicable. The report may be formal or informal, depending on the level of assessment performed, but should provide a clear picture of the results in terms of the programs, systems, and processes assessed. The assessment report should be clear, concise, accurate, and easy to understand, and should include only facts that directly relate to assessment observations and results. It should include sufficient information to enable the assessed organization to develop and implement appropriate

improvement plans. Specific report formats may vary considerably from one organization to the next. An independent assessment report usually includes the following sections:

- Executive summary
- Assessment scope
- Identification of team members
- Identification of personnel contacted
- Documents reviewed
- Work performance observed
- Assessment process and criteria
- Results of the assessment, including identification of areas for improvement, and/or strengths

g. Identify the function of common DOE managed oversight such as Chief of Defense Nuclear Safety (CDNS) reviews and ORRs.

The following is taken from DOE O 410.1.

Chief of Nuclear Safety/Chief of Defense Nuclear Safety

Develops and maintains a baseline list of known exemptions to 10 CFR 830 and exemptions or exceptions taken in prime contracts for nuclear facilities to directives identified in attachment 1 of DOE O 410.1.

Evaluates requests for exemptions to 10 CFR 830 and for exceptions or exemptions to directives identified in attachment 1 of DOE O 410.1 and for each request, provides the CTA a written summary of the evaluation along with a recommendation regarding concurrence.

Evaluates requests for revision or cancellation of regulations and directives listed in DOE 410.1, attachment 2; and, for each request, provides the CTA a written summary of the evaluation along with a recommendation regarding concurrence.

Evaluates new and revised regulations and other documents for inclusion in DOE O 410.1, attachments 1 and 2, and provides the CTA a written summary of the evaluation and justification for each document recommended for inclusion as early in the coordination process as possible, preferably during pre-coordination.

Evaluates requests for proposals and new or revised nuclear facility contracts for adequacy of the directives included and provides the CTA written summaries of the evaluations along with recommendations regarding concurrence.

Maintains a list of approved deviations from the double contingency principle.

Evaluates the use of any methodology other than that given in table 2-1, appendix A of subpart B to 10 CFR 830 to prepare a DSA for a hazard category 1, 2 or 3 nuclear facility and for each request, provides the CTA a written summary of the evaluation along with a recommendation regarding concurrence.

Operational Readiness Reviews

The following is taken from DOE-STD-3006-2010.

The readiness review process was developed to provide a high degree of confidence that new and restarted DOE nuclear facility operations will be conducted as intended by the design and safety basis. A graded independent review approach is used. Independence was deemed necessary to avoid conflicts of interest that could compromise reviewer ability to objectively determine the status of the proposed operation.

Reviews are based on records review, observation of equipment and operations, and interviews of relevant personnel. In certain cases, two reviews are required (contractor and Federal) due to the current degree of confidence in contractor assurance systems.

Prior to the formal process, the method for DOE to authorize the commencement of new nuclear operations was unclear. Both extremes of readiness verification were possible. cursory reviews would raise safety issues while open-ended, extensive reviews could continue indefinitely introducing significant delay and expense to DOE programs.

Mandatory Performance Activities:

h. Plan, coordinate, and conduct a safety focused assessment, including writing an assessment report, and participating in welcome and closeout briefs.

This is a performance-based KSA. The Qualifying Official will evaluate its completion.

19. Occupational safety personnel must demonstrate a working level knowledge of fire hazards and the principles and methods of fire prevention and protection.

a. Discuss fire chemistry (i.e., four required elements) and role of this chemistry in fire prevention and protection efforts.

The following is taken from FirefighterCentral.com, “What is Fire?”

To better understand the properties of fire we can examine extinguishment techniques. The fire tetrahedron is based on the components of extinguishing a fire. Each component represents a property of flaming fire; fuel, oxygen, heat, and chemical chain reaction. Extinguishment is based upon removing or hindering any one of these properties. The most common property to be removed is heat. Heat is commonly eliminated by using water. Water is used because it absorbs heat extremely well and is cost efficient.

b. Describe workplace and facility inspection procedures necessary to identify fire hazards and assess the status of compliance with applicable regulations.

The following is taken from DOE Order 5480.7A (archived).

Documented evaluations of the fire protection program, including field walkdowns of facilities, shall be performed as follows:

- Facilities/contractors shall be assessed to establish that they conform to DOE fire protection criteria.
- Minimum frequency:
 - Headquarters:
 - Program secretarial officer assessment of field offices, 3 years
 - Assistant Secretary for Environment assessment of program offices, 3 years
 - Field Office:

- Field office assessment of the fire protection program of each contractor, 2 years
- Contractors/facility managers:
 - Annual fire protection assessments shall be made of facilities valued in excess of \$50 million.
 - Fire protection assessments shall be made at least every two years of facilities plus equipment valued at \$10 million to \$50 million.
 - Remaining facilities shall be assessed at least every 3 years or at frequencies determined by the AHJ.
 - Comprehensive assessments of fire protection program elements shall be made every 2 years.
 - Copies of the two most recent assessment reports shall be kept on file.

Assessments shall include an evaluation of the following elements of the fire protection program:

- Program related:
 - Comprehensiveness of the fire protection program
 - Procedures for engineering design and review
 - Procedures for maintenance, testing, and inspection
 - Fire protection engineering staff (number, qualifications, training)
 - Fire suppression organization (personnel and training)
 - Fire suppression mutual aid agreements
 - Management support
 - Exemptions and documented equivalences
- Facility related:
 - Fire protection of safety class equipment
 - Life safety considerations
 - Fire protection of vital programs
 - Fire protection of high value property
 - Fire suppression equipment
 - Water runoff
 - Pre-fire plans
 - Fire apparatus accessibility
 - Completeness of fire hazard analyses (FHAs)
 - Fire barrier integrity
 - Completeness of fire loss potential maximum possible fire loss (MPFL)/maximum credible fire loss determinations
 - Fire safety training
- Combined aspects (program and facility):
 - Inspection, testing, and maintenance reports
 - Adequacy of facility appraisal reports
 - Tests of fire suppression systems, water supplies, and procedures for maintaining these in working order
 - Administrative controls
 - Temporary protection and compensatory measures
 - Status of findings from previous assessments
 - Conformance with applicable orders, codes, and standards

The purpose of FHAs is to comprehensively assess the risk from fire within individual fire areas in a DOE facility in relation to existing or proposed fire protection so as to ascertain whether the objectives are met. A graded FHA, that reflects the risks from fire in a facility, shall be performed for new facilities as directed by DOE O 420.1B, *Facility Safety*. A DSA that addresses the following elements will satisfy the requirements for an FHA. A graded FHA shall contain, but not be limited to the following elements:

- Description of construction
- Protection of essential safety class equipment
- Fire protection features
- Description of fire hazards
- Life safety considerations
- Critical process equipment
- High value property
- Damage potential
- Fire department/brigade response
- Recovery potential
- Potential for a toxic, biological, and/or radiation incident due to a fire
- Emergency planning
- Security considerations related to fire protection
- Natural hazards impact on fire safety
- Exposure fire potential, including the potential for fire spread between fire areas

An FHA shall be performed under the direction of a qualified fire protection engineer.

c. Describe fire protection considerations that must be addressed in the review of proposed or existing processes and operations, and identify appropriate control measures.

The following is taken from the City of Scottsdale, Design Standards & Policies Manual.

Adequate fire protection design must coordinate compliance with building and fire codes, site design policies, and public infrastructure needs. The principal considerations for fire protection are addressed online in codes, ordinances, and regulatory documents.

Examples of principal considerations for building design include the following:

- Fuel load
- Building structure size
- Construction methods
- Built-in fire protection, such as fire sprinklers, fire alarms, hose valves, etc.
- Number of occupants
- Hazard level of the use of the structure

Site planning considerations include the following:

- Building access by fire trucks
- Site access from adjacent streets
- Water supply in terms of system pressure and volume capacity

Examples of how these considerations work together:

- The required number of access points depends on the volume of the fuel load (number of structures, square footage of structures, and/or hazard level).
- Topography (hillside, washes, etc.).

- Available water volume influences on fire protection planning (gallons per minute, pressure and hydrant systems, built in fire protection and operations).
- Remediation of site challenges to provide appropriate access, adequate water supply, or overcoming difficult topography may be accomplished by increasing the protection level of construction methods and materials.
- Remediation may also be accomplished using built-in fire protection such as increasing the protection level of fire sprinklers, hose valves, fire alarms, etc.
- Many remediation methods are available in the city code, and may require staff approval, or require a variance. Considerations of remediation methods and consequences should start during or immediately following pre-application and should be concluded as much as possible prior to case approval. This will facilitate a successful and timely review and approval of building plans, improvement plans, and deferred shop drawings.

d. Discuss the need to develop, maintain, and implement work procedures that focus on the prevention of fires and explosions, such as hot work permits, fire watches, and proper handling and storage of flammable materials.

The following is taken from DOE Order 5480.7A (archived).

DOE Order 5480.7A, *Fire Protection*, section 9, states: “Facilities shall have procedures governing the use and storage of combustible, flammable, radioactive, and hazardous materials so as to minimize the risk from fire. Such procedures shall also exist for activities, such as smoking limitations, isolation of hot work, and other fire prevention measures, which contribute to the decrease in fire risk.”

e. Discuss and assess applicability of fire detection system requirements.

The following is taken from DOE-STD-1088-95.

Fire protection is concerned with preventing or minimizing the direct and indirect consequences of fire. It also includes aspects of the following perils as they relate to fire protection: explosion, natural phenomenon, smoke, and water damage from fire.

- Any system designed to detect, extinguish, and limit the extent of fire damage or enhance life safety. Where redundant fire protection systems are required, any two of the following will satisfy that requirement. These include the following:
 - Automatic suppression systems, such as fire sprinklers, foam, gaseous, explosion suppression, or other specialized extinguishing systems plus appropriate alarms. An adequate supply, storage, and distribution system is an essential element.
 - Automatic fire detection, occupant warning, manual fire alarm, and fire alarm reporting systems combined with properly equipped and adequately trained fire departments or brigades.
 - Fire barrier systems or combinations of physical separation and barriers for outdoor locations.
 - Other systems, such as alternate process control systems, as approved by the AHJ.

f. Discuss and assess applicability of portable and fixed fire suppression equipment requirements.

The following is taken from 29 CFR 1910.157.

29 CFR 1910.157, “Portable Fire Extinguishers,” covers portable extinguishers. These are some of the highlights. The employer shall provide portable fire extinguishers and shall mount, locate, and identify them so that they are readily accessible to employees without subjecting the employees to possible injury. Only approved portable fire extinguishers shall be used to meet requirements. The employer shall ensure that portable fire extinguishers are maintained in a fully charged and operable condition and kept in their designated places at all times except during use.

Portable fire extinguishers shall be provided for employee use and selected and distributed based on the classes of anticipated workplace fires and on the size and degree of hazard which would affect their use. The employer shall distribute portable fire extinguishers for use by employees on class A, class B, and class C fires.

The employer shall be responsible for the inspection, maintenance, and testing of all portable extinguishers in the workplace. The employer shall ensure that portable fire extinguishers are subjected to an annual maintenance check.

The following is taken from 29 CFR 1910.160.

29 CFR 1910.160, “Fixed Extinguishing Systems, General,” covers fixed extinguishers. These are some of the highlights. Fixed extinguishing system components and agents shall be designed and approved for use on the specific fire hazards they are expected to control or extinguish. The employer shall provide a distinctive alarm or signaling system that complies with 29 CFR 1910.165, “Employee Alarm Systems,” and is capable of being perceived above ambient noise or light levels, on all extinguishing systems in those portions of the workplace covered by the extinguishing system is discharging. These areas shall be posted with hazard or caution signs to warn employees against entry into discharge areas.

The employer shall train employees designated to inspect, maintain, operate, or repair fixed extinguishing systems and annually review their training to keep them up-to-date.

g. Discuss and assess application of requirements related to basic design principles in the National Fire Protection Association 101, Life Safety Code, including emergency egress, evacuation, and other related program elements.

The following is taken from 29 CFR 1910.34 through 29 CFR 1910.37.

An employer who demonstrates compliance with the exit route provisions of NFPA 101-2009, will be deemed to be in compliance with the requirements of 29 CFR 1910.34, “Coverage and Definitions,” 29 CFR 1910.35, “Compliance With NFPA 101- 2000”, 29 CFR 1910.36, “Design and Construction Requirements for Exit Routes,” and 29 CFR 1910.37, “Maintenance, Safeguards, and Operational Fixtures for Exit Routes.” Exit routes must meet the following design and construction requirements:

- An exit route must be permanent.
- An exit must be separated by fire resistant materials.
- Openings into an exit must be limited.
- The number of exit routes must be adequate—two exit routes.
- There must be exit discharge.
- An exit door must be unlocked.
- A side-hinged exit door must be used.

- The capacity of an exit route must be adequate.
- An exit route must meet minimum height and width requirements.
- An outdoor exit route is permitted.

Rules for maintenance, safeguards, and operational features for exit routes are:

- The danger to employees must be minimized.
- Lighting and marking must be adequate and appropriate.
- The fire retardant properties of paints or solutions must be maintained.
- Exit routes must be maintained during construction, repairs, or alterations.
- An employee alarm system must be operable.

h. Discuss role and purpose of fire protection design considerations, including fireproof and fire resistant structures, firewalls, and fire curtains.

The following is taken from DOE O 420.1B.

Design Considerations

A comprehensive fire protection design program for facilities and supporting systems must be developed, implemented, and maintained to include the following elements:

- A reliable and adequate supply of water for fire suppression.
- Noncombustible construction materials for facilities exceeding the size limits established by DOE.
- Complete fire-rated construction and barriers, commensurate with the applicable codes and fire hazards, to isolate hazardous areas and minimize fire spread and loss potential consistent with limits as defined by DOE.
- Automatic fire extinguishing systems throughout all significant facilities and in all facilities and areas with potential for loss of safety class systems, significant life safety hazards, unacceptable program interruption, or fire loss potential in excess of limits defined by DOE.
- Redundant fire protection systems in areas where
 - safety class systems are vulnerable to fire damage, and no redundant safety capability exists outside of the fire area of interest
 - the MPFL exceeds limits established by DOE
- In new facilities, redundant safety class systems located in separate fire areas.
- A means to notify emergency responders and building occupants of a fire.
- Emergency egress and illumination for safe facility evacuation in the event of fire as required by applicable codes or FHA.
- Physical access and appropriate equipment that is accessible for effective fire department intervention.
- A means to prevent the accidental release of significant quantities of contaminated products of combustion and fire-fighting water to the environment, such as ventilation control and filter systems and curbs and dikes. Such features would only be necessary if required by the FHA or DSA in conjunction with other facility or site environmental protection measures.
- A means to address fire and related hazards that are unique to DOE and not addressed by industry codes and standards. Mitigation features may consist of isolation, segregation or the use of special fire control systems as determined by the FHA.

- Fire protection systems designed such that their inadvertent operation, inactivation, or failure of structural stability will not result in the loss of vital safety functions or inoperability of safety class systems as determined by the DSA.

Firewalls

The following is taken from Linux, Firewall.

There are three main classifications of fire walls: firewalls, fire barrier walls, and high challenge firewalls. The common use of language typically includes all three when referring to a firewall unless distinguishing between them is necessary.

- A firewall is a wall separating transformers, structures, or buildings or a wall subdividing a building to prevent the spread of fire and having a fire resistance rating and structural stability.
- A fire barrier wall, also referred to as a fire partition, is a fire-rated wall assembly which is not a fire wall. Typically, the main differences are that a fire barrier wall is not structurally stable, and does not extend through the roof, or to the underside of the floor above.

Fire barrier walls are continuous from an exterior wall to an exterior wall, or from a floor below to a floor or roof above, or from one fire barrier wall to another fire barrier wall, fire wall, or high challenge fire wall having a fire resistance rating of at least equal rating as required for the fire barrier wall. They are continuous through all concealed spaces, but are not required to extend through concealed spaces if the construction assembly forming the bottom of the space has a fire resistance rating at least equal of the fire barrier wall.

A high challenge fire wall is a wall used to separate transformers, structures, or buildings or a wall subdividing a building with high fire challenge occupancies, having enhanced fire resistance ratings and enhanced appurtenance protection to prevent the spread of fire, and having structural stability.

Portions of structures that are subdivided by fire walls are permitted to be considered separate buildings, in that fire walls have sufficient structural stability to maintain the integrity of the wall in the event of the collapse of the building construction on either side of the wall.

Fire Curtain

The following is taken from I. Weiss, Fire Safety Curtains.

Most cities and states require a proscenium fire safety curtain in theaters, school auditoriums, and other public performance spaces.

There are two basic types available.

Straight Lift Curtain

A straight lift fire curtain is used in theaters where the area above the proscenium is equal to or greater than the overall height of the proscenium (standard fly loft). The curtain is stored as a straight panel above the proscenium.

This type of curtain is usually rigged for manual operation using counterweight or a winch. Motorization is possible.

Brail Lift Curtain

In theaters where the space above the proscenium is less than the proscenium opening a brail curtain is used. This curtain is stored in small folds in an accordion-like manner, which takes up the least amount of space. This type of curtain requires a brail winch for lifting. The winch is usually motorized, but can be manual if necessary.

i. Discuss health and safety hazards of currently employed fire suppressant systems.

The following is taken from 29 CFR 1910.160.

Total flooding systems with potential health and safety hazards to employees:

- The employer shall provide an emergency action plan.
- On all total flooding systems the employer shall provide a pre-discharge employee alarm.
- The employer shall provide automatic actuation of total flooding systems by means of an approved fire detection device installed and interconnected with a pre-discharge employee alarm system to give employees time to safely exit from the discharge area prior to system discharge.

The following is taken from 29 CFR 1910.161.

Dry chemical systems with potential health and safety hazards to employees:

- The employer shall ensure that dry chemical agents are compatible with any foams or wetting agents with which they are used.
- The employer may not mix together dry chemical extinguishing agents of different compositions.
- The employer will provide a pre-discharge employee alarm which will give employees time to safely exit from the discharge area prior to system discharge.
- The employer shall sample the dry chemical supply of all but stored pressure systems at least annually to ensure that the dry chemical supply is free of moisture which may cause the supply to cake or form lumps.
- The employer shall ensure that the rate of application of dry chemicals is such that the designed concentration of the system will be reached within thirty seconds of initial discharge.

The following is taken from 29 CFR 1910.162.

Gaseous agent systems with potential health and safety hazards to employees:

- Agents used for initial supply and replenishment shall be of the type approved for the system's application.
- The employer shall ensure that the designed concentration of gaseous agents is maintained until the fire has been extinguished or is under control.
- The employer shall ensure that employees are not exposed to toxic levels of gaseous agent or its decomposition products.

- The employer shall ensure that the designed extinguishing concentration is reached with thirty seconds of initial discharge except for Halon systems which must take ten seconds.
- The employer shall provide a distinctive pre-discharge employee alarm capable of being perceived above ambient light or noise levels when agent design concentrations exceed the maximum safe level for employee exposure.

j. Discuss cutting and welding safety, including activities in confined spaces.

The following is taken from 29 CFR 1910.252.

Cutting or welding shall be permitted only in areas that are or have been made fire safe. When work cannot be moved practically, as in most construction work, the area shall be made safe by removing combustibles from ignition sources. No welding, cutting, or other hot work shall be performed on used drums, barrels, tanks, or other containers until they have been cleaned so thoroughly as to make absolutely certain that there are no flammable materials present or any substances such as greases, tars, acids, or other materials which when subjected to heat, might produce flammable or toxic vapors. All hollow spaces, cavities, or containers shall be vented to permit the escape of air or gases before preheating, cutting, or welding.

Confined spaces:

- Accidental contact—when equipment is not in use, all electrodes shall be removed from the holders and the holders carefully located so that accidental contact cannot occur and the machine be disconnected from the power source.
- Torch valve—to eliminate the possibility of gas escaping through leaks or improperly closed valves, the torch valve shall be closed and the gas supply to the torch shut off at some point outside the confined area. When the torch is not in use, the torch and hose shall also be removed from the confined space.

k. Conduct a fire protection walkthrough with a qualified fire protection engineer or an FP FAQs qualified individual to identify and describe fire protection equipment and discuss hazards.

This is a performance-based KSA. The Qualifying Official will evaluate its completions. The following information from 29 CFR 1910 may be helpful.

Portable Fire Extinguishers

The following is taken from 29 CFR 1910.157.

The ultimate responsibility for the inspection, maintenance and testing of portable fire extinguishers lies with the employer. The actual inspection, maintenance, and testing may, however, be conducted by outside contractors with whom the employer has arranged to do the work.

If the employer should elect to perform the inspection, maintenance, and testing requirements in-house, then the employer must make sure that those persons doing the work have been trained to do the work and to recognize problem areas which could cause an extinguisher to be inoperable. The NFPA provides excellent guidelines in its standard for portable fire extinguishers. The employer may also check with the manufacturer of the unit that has been purchased and obtain guidelines on inspection, maintenance, and

testing. Hydrostatic testing is a process that should be left to contractors or individuals using suitable facilities and having the training necessary to perform the work.

Anytime the employer has removed an extinguisher from service to be checked or repaired, alternate equivalent protection must be provided. Alternate equivalent protection could include replacing the extinguisher with one or more units having equivalent or equal ratings, posting a fire watch, restricting the unprotected area from employee exposure, or providing a hose system ready to operate.

Hydrostatic testing. The employer may contract for hydrostatic testing. However, if the employer wishes to provide the testing service, certain equipment and facilities must be available. Employees should be made aware of the hazards associated with hydrostatic testing and the importance of using proper guards and water pressures. Severe injury can result if extinguisher shells fail violently under hydrostatic pressure.

Standpipe and Hose Systems

The following is taken from 29 CFR 1910.158.

Employers must make sure that standpipes are protected so that they can be relied upon during a fire emergency. This means protecting the pipes from mechanical and physical damage. There are various means for protecting the equipment such as, but not limited to, enclosing the supply piping in the construction of the building, locating the standpipe in an area which is inaccessible to vehicles, or locating the standpipe in a stairwell.

The employer should keep fire protection hose equipment in cabinets or inside protective covers which will protect it from the weather elements, dirt or other damaging sources. Cabinets or protective covers must be easily removed or opened to ensure that hose and nozzle are accessible. When the employer places hose in a cabinet, the employer must make sure that the hose and nozzle are accessible to employees without subjecting them to injury. To make sure that the equipment is readily accessible, the employer must also make sure that the cabinets used to store equipment are kept free of obstructions and other equipment which may interfere with the fast distribution of the fire hose stored in the cabinet.

The employer must ensure that employees who use standpipe and hose systems can reach the hose rack and hose valve without the use of portable equipment such as ladders. Hose reels are encouraged for use because one employee can retrieve the hose, charge it, and place it into service without much difficulty.

When the employer elects to provide small hose in lieu of portable fire extinguishers, those hose stations being used for the substitution must have hose attached and ready for service. However, if more than the necessary amount of small hose outlets is provided, hose does not have to be attached to those outlets that would provide redundant coverage. Further, where the installation of hose on outlets may expose the hose to extremely cold climates, the employer may store the hose in another location provided it is readily available and can be connected to the outlet when needed.

Automatic Sprinkler Systems

The following is taken from 29 CFR 1910.159.

It is important that any sprinkler system maintenance be done only when there is minimal employee exposure to the fire hazard. For example, if repairs or changes to the system are to be made, they should be made during those hours when employees are not working or are not occupying that portion of the workplace protected by the portion of the system which has been shut down.

The water supply to a sprinkler system is one of the most important factors an employer should consider when evaluating a system. Obviously, if there is no water supply, the system is useless. Water supplies can be lost for various reasons such as improperly closed valves, excessive demand, broken water mains, and broken fire pumps. The employer must be able to determine if or when this type of condition exists either by performing a main drain test or visual inspection. Another problem may be an inadequate water supply. For example, a light hazard occupancy may, through rehabilitation or change in tenants, become an ordinary or high hazard occupancy. In such cases, the existing water supply may not be able to provide the pressure or duration necessary for proper protection. Employers must ensure that proper design and tests have been made to ensure an adequate water supply.

Piping which is exposed to corrosive atmospheres, either chemical or natural, can become defective to the extent that it is useless. Employers must ensure that piping is protected from corrosion by its material of construction (e.g., stainless steel), or by a protective coating (e.g., paint).

All components of the system must be protected from mechanical impact damage. This can be achieved with the use of mechanical guards or screens or by locating components in areas where physical contact is impossible or limited.

The most recognized sprinkler alarm is the water motor gong or bell that sounds when water begins to flow through the system. This is not however, the only type of acceptable water flow alarm. Any alarm that gives an indication that water is flowing through the system is acceptable. For example, a siren, a whistle, a flashing light, or similar alerting device which can transmit a signal to the necessary persons would be acceptable. The purpose of the alarm is to alert persons that the system is operating, and that some type of planned action is necessary.

For a sprinkler system to be effective there must be an adequate discharge of water spray from the sprinkler head. Any obstructions which hinder the designed density or spray pattern of the water may create unprotected areas which can cause fire to spread. There are some sprinklers that, because of the system's design, are deflected to specific areas. This type of obstruction is acceptable if the system's design takes it into consideration in providing adequate coverage.

20. Occupational safety personnel must demonstrate a working level knowledge of fall protection, including programs, training requirements, hazards and elimination or control.

- a. Discuss scope and content of the DOE and national regulations and standards associated with fall protection including:**
- **29 CFR 1926, Subpart M, Fall Protection**
 - **29 CFR 1910, Subpart F, Powered Platforms, Manlifts and Vehicle Mounted Work Platforms**
 - **29 CFR 1910 Subpart D and 1926 sections on walking and working surfaces, guardrails,**
 - **ANSI/ASSE Standards (e.g., Z359, Fall Protection Code series, A10.32, Fall protection Systems for Construction and Demolition).**

29 CFR 1926, Subpart M, Fall Protection

The following is taken from 29 CFR 1926.501.

29 CFR 1926.501, “Duty to Have Fall Protection,” sets forth requirements for employers to provide fall protection systems.

The employer shall determine if the walking/working surfaces on which its employees are to work have the strength and structural integrity to support employees safely. Employees shall be allowed to work on those surfaces only when the surfaces have the requisite strength and structural integrity.

Unprotected Sides and Edges

Each employee on a walking/working surface with an unprotected side or edge that is 6 feet or more above a lower level shall be protected from falling by the use of guardrail systems, safety net systems, or a personal fall arrest systems (PFAS).

Leading Edges

Each employee who is constructing a leading edge 6 feet or more above lower levels shall be protected from falling by guardrail systems, safety net systems, or a PFAS.

Each employee on a walking/working surface 6 feet or more above a lower level where leading edges are under construction, but who is not engaged in the leading edge work, shall be protected from falling by a guardrail system, safety net system, or a PFAS. If a guardrail system is chosen to provide the fall protection, and a controlled access zone has already been established for leading edge work, the control line may be used in lieu of a guardrail along the edge that parallels the leading edge.

Hoist Areas

Each employee in a hoist area shall be protected from falling 6 feet or more to lower levels by guardrail systems or a PFAS. If guardrail systems, or portions thereof, are removed to facilitate the hoisting operation, and an employee must lean through the access opening or out over the edge of the access opening, that employee shall be protected from fall hazards by a PFAS.

Holes

Each employee on walking/working surfaces shall be protected from falling through holes more than 6 feet above lower levels, by a PFAS, covers, or guardrail systems erected around such holes.

Each employee on a walking/working surface shall be protected from tripping in or stepping into or through holes by covers.

Each employee on a walking/working surface shall be protected from objects falling through holes by covers.

Each employee on the face of form work or reinforcing steel shall be protected from falling 6 feet or more to lower levels by a PFAS, safety net systems, or positioning device systems.

Ramps, Runways, and Other Walkways

Each employee on ramps, runways, and other walkways shall be protected from falling six feet or more to lower levels by guardrail systems.

Excavations

Each employee at the edge of an excavation 6 feet or more in depth shall be protected from falling by guardrail systems, fences, or barricades when the excavations are not readily seen because of plant growth or other visual barrier.

Each employee at the edge of a well, pit, shaft, and similar excavation 6 feet or more in depth shall be protected from falling by guardrail systems, fences, barricades, or covers.

Dangerous Equipment

Each employee less than 6 feet above dangerous equipment shall be protected from falling into or onto the dangerous equipment by guardrail systems or by equipment guards.

Each employee 6 feet or more above dangerous equipment shall be protected from fall hazards by guardrail systems, a PFAS, or safety net systems.

Overhand Bricklaying and Related Work

Each employee performing overhand bricklaying and related work 6 feet or more above lower levels, shall be protected from falling by guardrail systems, safety net systems, a PFAS, or shall work in a controlled access zone.

Each employee reaching more than 10 inches below the level of the walking/working surface on which they are working shall be protected from falling by a guardrail system, safety net system, or PFAS.

Roofing Work on Low-Slope Roofs

Each employee engaged in roofing activities on low-slope roofs, with unprotected sides and edges 6 feet or more above lower levels shall be protected from falling by guardrail systems, safety net systems, a PFAS, or a combination of warning line system and guardrail system, warning line system and safety net system, or warning line system and

PFAS, or warning line system and safety monitoring system. Or, on roofs 50 feet or less in width the use of a safety monitoring system alone is permitted.

Steep Roofs

Each employee on a steep roof with unprotected sides and edges 6 feet or more above lower levels shall be protected from falling by guardrail systems with toe boards, safety net systems, or a PFAS.

Precast Concrete Erection

Each employee engaged in the erection of precast concrete members and related operations such as grouting of precast concrete members, who is 6 feet or more above lower levels shall be protected from falling by guardrail systems, safety net systems, or a PFAS.

Residential Construction

Each employee engaged in residential construction activities 6 feet or more above lower levels shall be protected by guardrail systems, safety net system, or a PFAS unless another provision in paragraph (b) of this section provides for an alternative fall protection measure.

Wall Openings

Each employee working on, at, above, or near wall openings where the outside bottom edge of the wall opening is 6 feet or more above lower levels and the inside bottom edge of the wall opening is less than 39 inches above the walking/working surface, shall be protected from falling by the use of a guardrail system, a safety net system, or a PFAS.

29 CFR 1910, Subpart F, Powered Platforms, Manlifts and Vehicle Mounted Work Platforms

Powered Platforms

The following is taken from 29 CFR 1910.66.

Building owners shall base the information required in 29 CFR 1910.66, “Powered Platforms for Building Maintenance,” on the results of a field test of the installation before being placed into service and following any major alteration to an existing installation.

The assurance shall also be based on all other relevant available information, including, but not limited to, test data, equipment specifications and verification by a registered professional engineer.

Building owners of all installations, new and existing, shall inform the employer in writing that the installation has been inspected, tested and maintained in compliance with the requirements of 29 CFR 1910.66 and that all protection anchorages meet the requirements.

The employer shall not permit employees to use the installation prior to receiving assurance from the building owner that the installation meets the requirements.

The following requirements apply to affected parts of buildings that use working platforms for building maintenance:

- Structural supports, tie-downs, tie-in guides, anchoring devices and any affected parts of the building included in the installation shall be designed by or under the direction of a registered professional engineer experienced in such design.
- Exterior installations shall be capable of withstanding prevailing climatic conditions.
- The building installation shall provide safe access to, and egress from, the equipment and sufficient space to conduct necessary maintenance of the equipment.
- The affected parts of the building shall have the capability of sustaining all the loads imposed by the equipment.
- The affected parts of the building shall be designed so as to allow the equipment to be used without exposing employees to a hazardous condition.

Manlifts

The following is taken from 29 CFR 1910.68.

All new manlift installations and equipment installed shall meet the design requirements of the ASME A90.1-2009, *Safety Standard for Belt Manlifts*.

Floor openings for the up and down runs shall be not less than 28 inches nor more than 36 inches in width for a 12-inch belt; not less than 34 inches nor more than 38 inches for a 14-inch belt; and not less than 36 inches nor more than 40 inches for a 16-inch belt and shall extend not less than 24 inches, nor more than 28 inches from the face of the belt.

All floor openings for a given manlift shall be uniform in size and shall be approximately circular, and each shall be located vertically above the opening below it.

The clearance between the floor or mounting platform and the lower edge for the conical guard above it shall not be less than 7 feet 6 inches. Where this clearance cannot be obtained no access to the manlift shall be provided and the manlift runway shall be enclosed where it passes through such floor.

The landing space adjacent to the floor openings shall be free from obstruction and kept clear at all times. This landing space shall be at least 2 feet in width from the edge of the floor opening used for mounting and dismounting.

Adequate lighting, not less than 5-foot candles, shall be provided at each floor landing at all times when the lift is in operation.

The landing surfaces at the entrances and exits to the manlift shall be constructed and maintained as to provide safe footing at all times.

Where there is a travel of 50 feet or more between floor landings, one or more emergency landings shall be provided so that there will be a landing for every 25 feet or less of manlift travel.

Emergency landings shall be accessible from the up and down rungs of the manlift and shall give access to a ladder.

Emergency landings shall be completely enclosed with a standard railing and toe board.

Platforms constructed to give access to bucket elevators or other equipment for the purpose of inspection, lubrication, and repair may also serve as emergency landings under this rule. All such platforms will then be considered part of the emergency landing and shall be provided with standard railings and toe boards.

Guards on underside of floor openings—Fixed type. On the ascending side of the manlift floor openings shall be provided with a bevel guard or cone meeting the following requirements:

- The cone shall make an angle of not less than 45 degrees with the horizontal. An angle of 60 degrees or greater shall be used where ceiling heights permit.
- The lower edge of this guard shall extend at least 42 inches outward from any handhold on the belt. It shall not extend beyond the upper surface of the floor above.
- The cone shall be made of not less than No. 18 U.S. gauge sheet steel or material of equivalent strength or stiffness. The lower edge shall be rolled to a minimum diameter of one-half inch and the interior shall be smooth with no rivets, bolts or screws protruding.

Floating type—A floating type safety cone may be used. Such floating cones to be mounted on hinges at least 6 inches below the underside of the floor and so constructed as to actuate a limit switch should a force of 2 pounds be applied on the edge of the cone closest to the hinge. The depth of this floating cone need not exceed 12 inches.

Protection of entrances and exits—Guard rail requirement

The entrances and exits at all floor landings affording access to the manlift shall be guarded by a maze or a handrail equipped with self-closing gates. The rails shall be standard guardrails with toeboards meeting the provisions of 29 CFR 1910.23, “Guarding Floor and Wall Openings and Holes.” Gates, if used, shall open outward and shall be self-closing. Corners of gates shall be rounded. Maze or staggered openings shall offer no direct passage between enclosure and outer floor space.

Guards for openings—Construction

The floor opening at each landing shall be guarded on sides not used for entrance or exit by a wall, a railing and toe board or by panels of wire mesh of suitable strength. Such rails or guards shall be at least 42 inches in height on the up-running side and 66 inches on the down-running side.

- Bottom arrangement—Bottom landing

At the bottom landing the clear area shall be not smaller than the area enclosed by the guardrails on the floors above, and any wall in front of the down-running side of the belt shall be not less than 48 inches from the face of the belt. This space shall not be encroached upon by stairs or ladders.

The lower (boot) pulley shall be installed so that it is supported by the lowest landing served. The sides of the pulley support shall be guarded to prevent contact with the pulley or the steps. A mounting platform shall be provided in front or to one side of the up-run at the lowest landing, unless the floor level is such that the following requirement can be met: The floor or platform shall be at or above the point at which the upper surface of the ascending step completes its turn and

assumes a horizontal position. To guard against persons walking under a descending step, the area on the downside of the manlift shall be guarded. To guard against a person getting between the mounting platform and an ascending step, the area between the belt and the platform shall be protected by a guardrail.

- Top arrangements—Clearance from floor

A top clearance shall be provided of at least 11 feet above the top terminal landing. This clearance shall be maintained from a plane through each face of the belt to a vertical cylindrical plane having a diameter 2 feet greater than the diameter of the floor opening, extending upward from the top floor to the ceiling on the up-running side of the belt. No encroachment of structural or machine supporting members within this space will be permitted. There shall be a clearance of at least 5 feet between the center of the head pulley shaft and any ceiling obstruction. The center of the head pulley shaft shall be not less than 6 feet above the top terminal landing. An emergency grab bar or rail and platform shall be provided at the head pulley when the distance to the head pulley is over 6 feet above the top landing, otherwise only a grab bar or rail is to be provided to permit the rider to swing free should the emergency stops become inoperative. A fixed metal ladder accessible from the up and down run of the manlift shall be provided for the entire travel of the manlift. Such ladder shall be in accordance with the existing ANSI/American Standard Committee (ASC) A14.3-1956, *American National Standards for Ladders—Fixed—Safety Requirements*, and 29 CFR 1910.27, “Fixed Ladders.” Manlift rails shall be secured in such a manner as to avoid spreading, vibration, and misalignment.

Illumination—General

Both runs of the manlift shall be illuminated at all times when the lift is in operation. An intensity of not less than 1-foot candle shall be maintained at all points. Lighting of manlift runways shall be by means of circuits permanently tied in to the building circuits, or shall be controlled by switches at each landing. Where separate switches are provided at each landing, any switch shall turn on all lights necessary to illuminate the entire runway.

Vehicle-Mounted Work Platforms

The following is taken from 29 CFR 1910.67.

Aerial devices (aerial lifts) shall be designed and constructed in conformance with the applicable requirements of ANSI A 92.2-2009, *Vehicle Mounted Elevating and Rotating Work Platforms*.

Aerial devices include the following types of vehicle-mounted aerial devices used to elevate personnel to jobsites above ground:

- Extensible boom platforms
- Aerial ladders,
- Articulating boom platforms
- Vertical towers
- A combination of any of the above

Aerial equipment may be made of metal, wood, fiberglass reinforced plastic, or other material; may be powered or manually operated; and are deemed to be aerial lifts whether or not they are capable of rotating about a substantially vertical axis.

Aerial lifts may be field-modified for uses other than those intended by the manufacturer, provided the modification has been certified in writing by the manufacturer or by any other equivalent entity, such as a nationally recognized testing laboratory, to be in conformity with all applicable provisions of ANSI A92.2-2009, and to be at least as safe as the equipment was before modification.

29 CFR 1910 Subpart D and 1926 Sections on Walking and Working Surfaces, Guardrails

The following is taken from 29 CFR 1910.22.

29 CFR 1910.22, "General Requirements," applies to all permanent places of employment, except where domestic, mining, or agricultural work only is performed. Measures for the control of toxic materials are considered to be outside the scope of this section.

Housekeeping

All places of employment, passageways, storerooms, and service rooms shall be kept clean and orderly and in a sanitary condition.

The floor of every workroom shall be maintained in a clean and, so far as possible, a dry condition. Where wet processes are used, drainage shall be maintained, and false floors, platforms, mats, or other dry standing places should be provided where practicable.

To facilitate cleaning, every floor, working place, and passageway shall be kept free from protruding nails, splinters, holes, or loose boards.

Aisles and Passageways

Where mechanical handling equipment is used, sufficient safe clearances shall be allowed for aisles, at loading docks, through doorways and wherever turns or passage must be made. Aisles and passageways shall be kept clear and in good repairs, with no obstruction across or in aisles that could create a hazard. Permanent aisles and passageways shall be appropriately marked.

Covers and Guardrails

Covers and/or guardrails shall be provided to protect personnel from the hazards of open pits, tanks, vats, ditches, etc.

Floor Loading Protection

In every building or other structure, or part thereof, used for mercantile, business, industrial, or storage purposes, the loads approved by the building official shall be marked on plates of approved design which shall be supplied and securely affixed by the owner of the building, or his duly authorized agent, in a conspicuous place in each space to which they relate. Such plates shall not be removed or defaced but, if lost, removed, or defaced, shall be replaced by the owner or his agent. It shall be unlawful to place, or

cause, or permit to be placed, on any floor or roof of a building or other structure a load greater than that for which such floor or roof is approved by the building official.

1926 Sections on Walking and Working Surfaces, Guardrails

Refer to the previous section of this KSA for information about walking and working surfaces.

ANSI/ASSE Z359.1-2007

The following is taken from the ANSI/American Society of Safety Engineers, ANSI/ASSE Z359.1-2007.

ANSI/ASSE Z359.1-2007, *Safety Requirements for Personal Fall Arrest Systems, Subsystems and Components*, establishes requirements for the performance, design, marking, qualification, instruction, training, inspection, use, maintenance and removal from service of connectors, full body harnesses, lanyards, energy absorbers, anchorage connectors, fall arresters, vertical lifelines, and self-retracting lanyards comprising personal fall arrest systems for users within the capacity range of 130 to 310 pounds.

ANSI/ASSE Z359.1-2007 addresses equipment used in occupations requiring personal protection against falls from heights and applies to the manufacturers, distributors, purchasers and users of such equipment.

ANSI A10.32, Fall Protection Systems for Construction and Demolition Operations

The following is taken from Roads and Bridges, New Catch Phrases.

Recent changes to ANSI regulations regarding fall protection are significant for the construction industry. The new regulation, A10.32-2004, *Fall Protection Systems for Construction and Demolition Operations*, replaces the A10.14-1991 *Requirements for Safety Belts, Harnesses, Lanyards and Lifelines for Construction and Demolition Use*.

ANSI A10.32 sets new guidelines that pertain to equipment testing, performance, and training. Professional safety experts recently compared 24 definitions and conditions of the new standard, A10.32, with the previous, A10.14, as well as OSHA guidelines. The following highlights will help to quickly identify what changes need to be made to comply with the current regulations for fall protection.

The following are notable areas of change in which the new ANSI A10.32 and current OSHA regulations differ from the past:

- Body belts are no longer considered adequate for fall arrest. They are permitted for restraint and work positioning only. A full-body harness is required for fall arrest.
- Positioning device systems are no longer considered a fall restraint. ANSI defines a positioning device system as a combination of equipment that permits the user to use both hands freely while being supported on an elevated surface. OSHA's definition is similar, but calls it a body belt or body harness system rigged to allow an employee to be supported on an elevated vertical surface, such as a wall, and work with both hands free while leaning. It must be rigged to prevent a free fall no more than 2 ft and have an anchor strength of 3,000 lb.

- ANSI standards used in testing arresting force have changed, and the new ANSI A10.32 now differs from OSHA. ANSI allows 1,400 lb maximum and OSHA allows 1,800 lb. Standards assume that the load measured in testing is greater than the force experienced by the person by a factor of 1.4. Therefore, a measured load of 1,400 lb is considered equivalent to a force of 1,000 lb on the human body.
- A qualified person must now supervise the design, installation, and use of two types of equipment/processes, as per A10.32 and OSHA, where engineering consultation was once adequate, specifically:
 - Horizontal lifeline: Must be designed, installed and used under the supervision of a qualified person as part of a complete system with a safety factor of two; and
 - Anchorage: The sole specification of A10.14 was 5,000 lb per attached worker. But A10.32 has added an option of a system judged by a “qualified person” to have a safety factor of two is a more feasible process on many construction sites.
- Two new specifications are now indicated for the following conditions:
 - A capacity of 310 lb or greater is now needed when designed, tested and labeled accordingly as per A10.32. OSHA requires design and test for the higher weight, with 310-lb minimum; and
 - Carabiner: ANSI now requires that carabiners be self-closing, self-locking and capable of being opened only by two consecutive, deliberate actions. OSHA requires the locking type. Both require minimum tensile strength of 5,000-lb gate nose side load to 350 lb, with proof load to 3,600 lb.

Other changes are reflected in the categorization of equipment types and testing of materials. Some requirements, such as formal inspection, remain the same.

b. Describe a fall protection plan for a multistory building under construction detailing which fall protection methods are applicable to what stage of construction.

The following is taken from the U.S. Department of Labor, Occupational Safety and Health Administration, Sample Fall Protection Plan.

The following fall protection plan is a sample program prepared for the prevention of injuries associated with falls. A fall protection plan must be developed and evaluated on a site by site basis. It is recommended that erectors discuss the written fall protection plan with their OSHA area office prior to going on a jobsite.

Statement of Company Policy

(Company Name) is dedicated to the protection of its employees from on-the-job injuries. All employees of (Company Name) have the responsibility to work safely on the job. The purpose of this plan is to supplement our standard safety policy by providing safety standards specifically designed to cover fall protection on this job and to ensure that each employee is trained and made aware of the safety provisions which are to be implemented by this plan prior to the start of erection.

This fall protection plan addresses the use of other than conventional fall protection at a number of areas on the project, as well as identifying specific activities that require non-conventional means of fall protection. These areas include

- connecting activity
- leading edge work
- unprotected sides or edge
- grouting

This plan is designed to enable employers and employees to recognize the fall hazards on this job and to establish the procedures that are to be followed in order to prevent falls to lower levels or through holes and openings in walking/working surfaces. Each employee will be trained in these procedures and strictly adhere to them except when doing so would expose the employee to a greater hazard. If, in the employee's opinion, this is the case, the employee is to notify the foreman of the concern and the concern addressed before proceeding.

Safety policy and procedure on any one project cannot be administered, implemented, monitored and enforced by any one individual. The total objective of a safe, accident-free work environment can only be accomplished by a dedicated, concerted effort by every individual involved with the project from management down to the last employee. Each employee must understand their value to the company; the costs of accidents, both monetary, physical, and emotional; the objective of the safety policy and procedures; the safety rules that apply to the safety policy and procedures; and what their individual role is in administering, implementing, monitoring, and compliance of their safety policy and procedures. This allows for a more personal approach to compliance through planning, training, understanding, and cooperative effort, rather than by strict enforcement. If for any reason an unsafe act persists, strict enforcement will be implemented.

It is the responsibility of (name of competent person) to implement this fall protection plan. (Name of competent person) is responsible for continual observational safety checks of their work operations and to enforce the safety policy and procedures. The foreman also is responsible to correct any unsafe acts or conditions immediately. It is the responsibility of the employee to understand and adhere to the procedures of this plan and to follow the instructions of the foreman. It is also the responsibility of the employee to bring to management's attention any unsafe or hazardous conditions or acts that may cause injury to either themselves or any other employees. Any changes to this fall protection plan must be approved by (name of qualified person).

Fall Protection Systems to Be Used on This Project

Where conventional fall protection is infeasible or creates a greater hazard at the leading edge and during initial connecting activity, we plan to do this work using a safety monitoring system and expose only a minimum number of employees for the time necessary to actually accomplish the job. The maximum number of workers to be monitored by one safety monitor is six. We are designating the following trained employees as designated erectors and they are permitted to enter the controlled access zones and work without the use of conventional fall protection.

- Safety monitor
- Designated erector
- Designated erector

- Designated erector
- Designated erector
- Designated erector
- Designated erector

The safety monitor shall be identified by wearing an orange hard hat. The designated erectors will be identified by one of the following methods:

- They will wear a blue colored arm band.
- They will wear a blue colored hard hat.
- They will wear a blue colored vest.

Only individuals with the appropriate experience, skills, and training will be authorized as designated erectors. All employees that will be working as designated erectors under the safety monitoring system shall have been trained and instructed in the following areas:

- Recognition of the fall hazards in the work area
- Avoidance of fall hazards using established work practices that have been made known to the employees
- Recognition of unsafe practices or working conditions that could lead to a fall, such as windy conditions
- The function, use, and operation of safety monitoring systems, guardrail systems, body belt/harness systems, control zones and other protection to be used
- The correct procedure for erecting, maintaining, disassembling, and inspecting the system(s) to be used
- Knowledge of construction sequence or the erection plan

A conference will take place prior to starting work involving all members of the erection crew, crane crew and supervisors of any other concerned contractors. This conference will be conducted by the precast concrete erection supervisor in charge of the project. During the pre-work conference, erection procedures and sequences pertinent to this job will be thoroughly discussed and safety practices to be used throughout the project will be specified. Further, all personnel will be informed that the controlled access zones are off limits to all personnel other than those designated erectors specifically trained to work in that area.

Safety Monitoring System

A safety monitoring system means a fall protection system in which a competent person is responsible for recognizing and warning employees of fall hazards. The duties of the safety monitor are to perform the following tasks:

- Warn by voice when approaching the open edge in an unsafe manner.
- Warn by voice if there is a dangerous situation developing, which cannot be seen by another person involved with product placement, such as a member getting out of control.
- Make the designated erectors aware they are in a dangerous area.
- Be competent in recognizing fall hazards.
- Warn employees when they appear to be unaware of a fall hazard or are acting in an unsafe manner.
- Be on the same walking/working surface as the monitored employees and within visual sighting distance of the monitored employees.

- Be close enough to communicate orally with the employees.
- Not allow other responsibilities to encumber monitoring. If the safety monitor becomes too encumbered with other responsibilities, the monitor shall 1) stop the erection process; and 2) turn over other responsibilities to a designated erector; or 3) turn over the safety monitoring function to another designated, competent person. The safety monitoring system shall not be used when the wind is strong enough to cause loads with large surface areas to swing out of radius, or result in loss of control of the load, or when weather conditions cause the walking/working surfaces to become icy or slippery.

Control Zone System

A controlled access zone means an area designated and clearly marked, in which leading edge work may take place without the use of guardrail, safety net or PFASs to protect the employees in the area. Control zone systems shall comply with the following provisions:

- When used to control access to areas where leading edge and other operations are taking place the controlled access zone shall be defined by a control line or by any other means that restricts access.
- When control lines are used, they shall be erected not less than 6 feet nor more than 60 feet or half the length of the member being erected, whichever is less, from the leading edge.
- The control line shall extend along the entire length of the unprotected or leading edge and shall be approximately parallel to the unprotected or leading edge.
- The control line shall be connected on each side to a guardrail system or wall.
- Control lines shall consist of ropes, wires, tapes, or equivalent materials, and supporting stanchions as follows:
 - Each line shall be flagged or otherwise clearly marked at not more than 6-foot intervals with high-visibility material.
 - Each line shall be rigged and supported in such a way that its lowest point is not less than 39 inches from the walking/working surface and its highest point is not more than 45 inches from the walking/working surface.
 - Each line shall have a minimum breaking strength of 200 pounds.

Holes

All openings greater than 12 in. x 12 in. will have perimeter guarding or covering. All predetermined holes will have the plywood covers made in the precaster's yard and shipped with the member to the jobsite. Prior to cutting holes on the job, proper protection for the hole must be provided to protect the workers. Perimeter guarding or covers will not be removed without the approval of the erection foreman.

Precast concrete column erection through the existing deck requires that many holes be provided through this deck. These are to be covered and protected. Except for the opening being currently used to erect a column, all opening protection is to be left undisturbed. The opening being uncovered to erect a column will become part of the point of erection and will be addressed as part of this fall protection plan. This uncovering is to be done at the erection foreman's direction and will only occur immediately prior to "feeding" the column through the opening. Once the end of the column is through the slab opening, there will no longer exist a fall hazard at this location.

Implementation of Fall Protection Plan

The structure being erected is a multistory total precast concrete building consisting of columns, beams, wall panels, and hollow core slabs and double tee floor and roof members.

The following is a list of the products and erection situations on this job:

Columns

For columns 10 ft to 36 ft long, employees disconnecting crane hooks from columns will work from a ladder and wear a body belt/harness with lanyard and be tied off when both hands are needed to disconnect. For tying off, a vertical lifeline will be connected to the lifting eye at the top of the column, prior to lifting, to be used with a manually operated or mobile rope grab. For columns too high for the use of a ladder, 36 ft and higher, an added cable will be used to reduce the height of the disconnecting point so that a ladder can be used. This cable will be left in place until a point in erection that it can be removed safely. In some cases, columns will be unhooked from the crane by using an erection tube or shackle with a pull pin which is released from the ground after the column is stabilized.

The column will be adequately connected and/or braced to safely support the weight of a ladder with an employee on it.

Inverted Tee Beams

Employees erecting inverted tee beams, at a height of 6 to 40 ft, will erect the beam, make initial connections, and final alignment from a ladder. If the employee needs to reach over the side of the beam to bar or make an adjustment to the alignment of the beam, they will mount the beam and be tied off to the lifting device in the beam after ensuring the load has been stabilized on its bearing. To disconnect the crane from the beam an employee will stand a ladder against the beam. Because the use of ladders is not practical at heights above 40 ft, beams will be initially placed with the use of tag lines and their final alignment made by a person on a manlift or similar employee positioning systems.

Spandrel Beams

Spandrel beams at the exterior of the building will be aligned as closely as possible with the use of tag lines with the final placement of the spandrel beam made from a ladder at the open end of the structure. A ladder will be used to make the initial connections and a ladder will be used to disconnect the crane. The other end of the beam will be placed by the designated erector from the double tee deck under the observation of the safety monitor.

The beams will be adequately connected and/or braced to safely support the weight of a ladder with an employee on it.

Floor and Roof Members

During installation of the precast concrete floor and/or roof members, the work deck continuously increases in area as more and more units are being erected and positioned. Thus, the unprotected floor/roof perimeter is constantly modified with the leading edge changing location as each member is installed. The fall protection for workers at the

leading edge shall be ensured by properly constructed and maintained control zone lines not more than 60 ft away from the leading edge supplemented by a safety monitoring system to ensure the safety of all designated erectors working within the area defined by the control zone lines.

The hollow core slabs erected on the masonry portion of the building will be erected and grouted using the safety monitoring system. Grout will be placed in the space between the end of the slab and face shell of the concrete masonry by dumping from a wheelbarrow. The grout in the keyways between the slabs will be dumped from a wheelbarrow and then spread with long-handled tools, allowing the worker to stand erect facing toward the unprotected edge and back from any work deck edge.

Whenever possible, the designated erectors will approach the incoming member at the leading edge only after it is below waist height so that the member itself provides protection against falls.

Except for the situations described below, when the arriving floor or roof member is within 2 to 3 inches of its final position, the designated erectors can then proceed to their position of erection at each end of the member under the control of the safety monitor. Crane hooks will be unhooked from double tee members by designated erectors under the direction and supervision of the safety monitor.

Designated erectors, while waiting for the next floor or roof member, will be constantly under the control of the safety monitor for fall protection and are directed to stay a minimum of 6 ft from the edge. In the event a designated erector must move from one end of a member, which has just been placed at the leading edge, they must first move away from the leading edge a minimum of 6 ft and then progress to the other end while maintaining the minimum distance of 6 ft at all times.

Erection of double tees, where conditions require bearing of one end into a closed pocket and the other end on a beam ledge, restricting the tee legs from going directly into the pockets, require special considerations. The tee legs that are to bear in the closed pocket must hang lower than those at the beam bearing. The double tee will be “two-lined” in order to elevate one end higher than the other to allow for the low end to be ducked into the closed pocket using the following procedure.

The double tee will be rigged with a standard four-way spreader off of the main load line. An additional choker will be attached to the married point of the two-legged spreader at the end of the tee that is to be elevated. The double tee will be hoisted with the main load line and swung into a position as close as possible to the tee’s final bearing elevation. When the tee is in this position and stabilized, the whip line load block will be lowered to just above the tee deck. At this time, two erectors will walk out on the suspended tee deck at midspan of the tee member and pull the load block to the end of the tee to be elevated and attach the additional choker to the load block. The possibility of entanglement with the crane lines and other obstacles during this two lining process while raising and lowering the crane block on that second line could be hazardous to an encumbered employee. Therefore, the designated erectors will not tie off during any part of this process. While the designated erectors are on the double tee, the safety monitoring system will be used. After attaching the choker, the two erectors then step back on the previously erected tee deck and signal the crane operator to hoist the load with the whip

line to the elevation that will allow for enough clearance to let the low end tee legs slide into the pockets when the main load line is lowered. The erector, who is handling the lowered end of the tee at the closed pocket bearing, will step out on the suspended tee. An erection bar will then be placed between the end of the tee leg and the inside face of the pocketed spandrel member. The tee is barred away from the pocketed member to reduce the friction and lateral force against the pocketed member. As the tee is being lowered, the other erector remains on the tee which was previously erected to handle the other end. At this point the tee is slowly lowered by the crane to a point where the tee legs can freely slide into the pockets. The erector working the lowered end of the tee must keep pressure on the bar between the tee and the face of the pocketed spandrel member to very gradually let the tee legs slide into the pocket to its proper bearing dimension. The tee is then slowly lowered into its final erected position.

The designated erector should be allowed onto the suspended double tee, otherwise there is no control over the horizontal movement of the double tee and this movement could knock the spandrel off of its bearing or the column out of plumb. The control necessary to prevent hitting the spandrel can only be done safely from the top of the double tee being erected.

Loadbearing Wall Panels: The erection of the loadbearing wall panels on the elevated decks requires the use of a safety monitor and a controlled access zone that is a minimum of 25 ft and a maximum of 1/2 the length of the wall panels away from the unprotected edge, so that designated erectors can move freely and unencumbered when receiving the panels. Bracing, if required for stability, will be installed by ladder. After the braces are secured, the crane will be disconnected from the wall by using a ladder. The wall to wall connections will also be performed from a ladder.

Non-Loadbearing Panels (Cladding): The locating of survey lines, panel layout and other installation prerequisites (prewelding, etc.) for non-loadbearing panels (cladding) will not commence until floor perimeter and floor openings have been protected. In some areas, it is necessary because of panel configuration to remove the perimeter protection as the cladding is being installed. Removal of perimeter protection will be performed on a bay to bay basis, just ahead of cladding erection to minimize temporarily unprotected floor edges. Those workers within 6 ft of the edge, receiving and positioning the cladding when the perimeter protection is removed shall be tied off.

Detailing

Employees exposed to falls of 6 ft or more to lower levels, who are not actively engaged in leading edge work or connecting activity, such as welding, bolting, cutting, bracing, guying, patching, painting or other operations, and who are working less than 6 ft from an unprotected edge will be tied off at all times or guardrails will be installed. Employees engaged in these activities but who are more than 6 ft from an unprotected edge as defined by the control zone lines, do not require fall protection but a warning line or control lines must be erected to remind employees they are approaching an area where fall protection is required.

Conventional Fall Protection Considered for the Point of Erection or Leading Edge Erection Operations

Personal Fall Arrest Systems

In this particular erection sequence and procedure, PFASs requiring body belt/harness systems, lifelines and lanyards will not reduce possible hazards to workers and will create offsetting hazards during their usage at the leading edge of precast/prestressed concrete construction.

Leading edge erection and initial connections are conducted by employees who are specifically trained to do this type of work and are trained to recognize the fall hazards. The nature of such work normally exposes the employee to the fall hazard for a short period of time and installation of fall protection systems for a short duration is not feasible because it exposes the installers of the system to the same fall hazard, but for a longer period of time.

- It is necessary that the employee be able to move freely without encumbrance in order to guide the sections of precast concrete into their final position without having lifelines attached which will restrict the employee's ability to move about at the point of erection.
- A typical procedure requires 2 or more workers to maneuver around each other as a concrete member is positioned to fit into the structure. If they are each attached to a lifeline, part of their attention must be diverted from their main task of positioning a member weighing several tons to the task of avoiding entanglements of their lifelines or avoiding tripping over lanyards. Therefore, if these workers are attached to lanyards, more fall potential would result than from not using such a device. In this specific erection sequence and procedure, retractable lifelines do not solve the problem of two workers becoming tangled. In fact, such a tangle could prevent the lifeline from retracting as the worker moved, thus potentially exposing the worker to a fall greater than 6 ft. Also, a worker crossing over the lifeline of another worker can create a hazard because the movement of one person can unbalance the other. In the event of a fall by one person there is a likelihood that the other person will be caused to fall as well. In addition, if contamination such as grout (during hollow core grouting) enters the retractable housing it can cause excessive wear and damage to the device and could clog the retracting mechanism as the lanyard is dragged across the deck. Obstructing the cable orifice can defeat the device's shock-absorbing function, produce cable slack and damage, and adversely affect cable extraction and retraction.
- Employees tied to a lifeline can be trapped and crushed by moving structural members if the employee becomes restrained by the lanyard or retractable lifeline and cannot get out of the path of the moving load. The sudden movement of a precast concrete member being raised by a crane can be caused by a number of factors. When this happens, a connector may immediately have to move a considerable distance to avoid injury. If a tied off body belt/harness is being used, the connector could be trapped. Therefore, there is a greater risk of injury if the connector is tied to the structure for this specific erection sequence and procedure. When necessary to move away from a retractable device, the worker cannot move at a rate greater than the device locking speed, typically 3.5 to 4.5 ft/sec. When moving toward the device it is necessary to move at a rate which does not permit cable slack to build up. This slack may cause cable retraction acceleration and

cause a worker to lose balance by applying a higher than normal jerking force on the body when the cable suddenly becomes taut after building up momentum. This slack can also cause damage to the internal spring-loaded drum, uneven coiling of cable on the drum, and possible cable damage.

The factors causing sudden movements for this location include

- cranes
- operator error
- site conditions
- mechanical failure
- structural failure
- rigging failure
- crane signal/radio communication failure

Weather conditions

- wind—particularly a problem with the large surface areas of precast concrete members.
- snow/rain
- fog
- cold—causing slowed reactions or mechanical problems.

Structure/product conditions

- lifting eye failure
- bearing failure or slippage
- structure shifting
- bracing failure
- product failure

Human error

- incorrect tag line procedure
- tag line hang-up
- incorrect or misunderstood crane signals
- misjudged elevation of member
- misjudged speed of member
- misjudged angle of member

Anchorage or special attachment points could be cast into the precast concrete members if sufficient preplanning and consideration of erectors' position is done before the members are cast. Any hole or other attachment must be approved by the engineer who designed the member. It is possible that some design restrictions will not allow a member to be weakened by an additional hole; however, it is anticipated that such situations would be the exception, not the rule. Attachment points, other than on the deck surface, will require removal and/or patching. In order to remove and/or patch these points, requires the employee to be exposed to an additional fall hazard at an unprotected perimeter. The fact that attachment points could be available anywhere on the structure does not eliminate the hazards of using these points for tying off as discussed above. A logical point for tying off on double tees would be using the lifting loops, except that they must be cut off to eliminate a tripping hazard at an appropriate time.

Providing attachment at a point above the walking/working surface would also create fall exposures for employees installing their devices. Final positioning of a precast concrete member requires it to be moved in such a way that it must pass through the area that would be occupied by the lifeline and the lanyards attached to the point above. Resulting entanglements of lifelines and lanyards on a moving member could pull employees from the work surface. Also, the structure is being created and, in most cases, there is no structure above the members being placed.

Temporary structural supports, installed to provide attaching points for lifelines limit the space which is essential for orderly positioning, alignment and placement of the precast concrete members. To keep the lanyards a reasonable and manageable length, lifeline supports would necessarily need to be in proximity to the positioning process. A sudden shift of the precast concrete member being positioned because of wind pressure or crane movement could make it strike the temporary supporting structure, moving it suddenly and causing tied off employees to fall.

The time in manhours which would be expended in placing and maintaining temporary structural supports for lifeline attaching points could exceed the expended manhours involved in placing the precast concrete members. No protection could be provided for the employees erecting the temporary structural supports and these supports would have to be moved for each successive step in the construction process, thus greatly increasing the employee's exposure to the fall hazard.

The use of a cable strung horizontally between two columns to provide tie off lines for erecting or walking a beam for connecting work is not feasible and creates a greater hazard on this multi-story building for the following reasons:

- If a connector is to use such a line, it must be installed between the two columns. To perform this installation requires an erector to have more fall exposure time attaching the cable to the columns than would be spent to make the beam to column connection itself.
- If such a line is to be installed so that an erector can walk along a beam, it must be overhead or below him. For example, if a connector must walk along a 24 in. wide beam, the presence of a line next to the connector at waist level, attached directly to the columns, would prevent the connector from centering their weight over the beam and balancing themselves. Installing the line above the connector might be possible on the first level of a two-story column; however, the column may extend only a few feet above the floor level at the second level or be flush with the floor level. Attaching the line to the side of the beam could be a solution; however, it would require the connector to attach the lanyard below foot level which would most likely extend a fall farther than 6 ft.
- When lines are strung over every beam, it becomes more and more difficult for the crane operator to lower a precast concrete member into position without the member becoming fouled. Should the member become entangled, it could easily dislodge the line from a column. If a worker is tied to it at the time, a fall could be caused.

The ANSI A10.14, states that the anchor point of a lanyard or deceleration device should, if possible, be located above the wearer's belt or harness attachment. ANSI A10.14 also states that a suitable anchorage point is one which is located as high as possible to

prevent contact with an obstruction below should the worker fall. Most manufacturers also warn in the user's handbook that the safety block/retractable lifeline must be positioned above the D-ring (above the work space of the intended user) and OSHA recommends that fall arrest and restraint equipment be used in accordance with the manufacturer's instructions.

Attachment of a retractable device to a horizontal cable near floor level or using the inserts in the floor or roof members may result in increased free fall due to the dorsal D-ring of the full-body harness riding higher than the attachment point of the snaphook to the cable or insert (e.g., 6 ft tall worker with a dorsal D-ring at 5 ft above the floor or surface, reduces the working length to only 1 ft, by placing the anchorage 5 ft away from the fall hazard). In addition, impact loads may exceed maximum fall arrest forces because the fall arrest D-ring would be 4 to 5 ft higher than the safety block/retractable lifeline anchored to the walking/working surface; and the potential for swing hazards is increased. Manufacturers also require that workers not work at a level where the point of snaphook attachment to the body harness is above the device because this will increase the free-fall distance and the deceleration distance and will cause higher forces on the body in the event of an accidental fall.

Manufacturers recommend an anchorage for the retractable lifeline which is immovably fixed in space and is independent of the user's support systems. A moveable anchorage is one which can be moved around (such as equipment or wheeled vehicles) or which can deflect substantially under shock loading (such as a horizontal cable or very flexible beam). In the case of a very flexible anchorage, a shock load applied to the anchorage during fall arrest can cause oscillation of the flexible anchorage such that the retractable brake mechanism may undergo one or more cycles of locking/unlocking/locking (ratchet effect) until the anchorage deflection is dampened. Therefore, use of a moveable anchorage involves critical engineering and safety factors and should only be considered after fixed anchorage has been determined to be not feasible.

Horizontal cables used as an anchorage present an additional hazard due to amplification of the horizontal component of maximum arrest force (of a fall) transmitted to the points where the horizontal cable is attached to the structure. This amplification is due to the angle of sag of a horizontal cable and is most severe for small angles of sag. For a cable sag angle of 2 degrees the horizontal force on the points of cable attachment can be amplified by a factor of 15.

It is also necessary to install the retractable device vertically overhead to minimize swing falls. If an object is in the worker's swing path (or that of the cable) hazardous situations exist: 1) due to the swing, horizontal speed of the user may be high enough to cause injury when an obstacle in the swing fall path is struck by either the user or the cable; 2) the total vertical fall distance of the user may be much greater than if the user had fallen only vertically without a swing fall path.

With retractable lines, overconfidence may cause the worker to engage in inappropriate behavior, such as approaching the perimeter of a floor or roof at a distance appreciably greater than the shortest distance between the anchorage point and the leading edge. Though the retractable lifeline may arrest a worker's fall before he or she has fallen a few feet, the lifeline may drag along the edge of the floor or beam and swing the worker like a pendulum until the line has moved to a position where the distance between the

anchorage point and floor edge is the shortest distance between those two points. Accompanying this pendulum swing is a lowering of the worker, with the attendant danger that he or she may violently impact the floor or some obstruction below.

The risk of a cable breaking is increased if a lifeline is dragged sideways across the rough surface or edge of a concrete member at the same moment that the lifeline is being subjected to a maximum impact loading during a fall. The typical 3/16 in. cable in a retractable lifeline has a breaking strength of from 3000 to 3700 lbs.

The competent person, who can take into account the specialized operations being performed on this project, should determine when and where a designated erector cannot use a PFAS.

Safety Net Systems

The nature of this particular precast concrete erection worksite precludes the safe use of safety nets where point of erection or leading edge work must take place.

- To install safety nets in the interior high bay of the single story portion of the building poses rigging attachment problems. Structural members do not exist to which supporting devices for nets can be attached in the area where protection is required. As the erection operation advances, the location of point of erection or leading edge work changes constantly as each member is attached to the structure. Due to this constant change it is not feasible to set net sections and build separate structures to support the nets.
- The nature of the erection process for the precast concrete members is such that an installed net would protect workers as they position and secure only one structural member. After each member is stabilized the net would have to be moved to a new location (this could mean a move of 8 to 10 ft or the possibility of a move to a different level or area of the structure) to protect workers placing the next piece in the construction sequence. The result would be the installation and dismantling of safety nets repeatedly throughout the normal work day. As the time necessary to install a net, test, and remove it is significantly greater than the time necessary to position and secure a precast concrete member, the exposure time for the worker installing the safety net would be far longer than for the workers whom the net is intended to protect. The time exposure repeats itself each time the nets and supporting hardware must be moved laterally or upward to provide protection at the point of erection or leading edge.
- Strict interpretation of 29 CFR 1926.502, "Fall Protection Systems Criteria and Practices," requires that operations shall not be undertaken until the net is in place and has been tested. With the point of erection constantly changing, the time necessary to install and test a safety net significantly exceeds the time necessary to position and secure the concrete member.
- Use of safety nets on exposed perimeter wall openings and open-sided floors, causes attachment points to be left in architectural concrete which must be patched and filled with matching material after the net supporting hardware is removed. In order to patch these openings, additional numbers of employees must be suspended by swing stages, boatswain chairs or other devices, thereby increasing the amount of fall exposure time to employees.
- Installed safety nets pose an additional hazard at the perimeter of the erected structure where limited space is available in which members can be turned after

being lifted from the ground by the crane. There would be a high probability that the member being lifted could become entangled in net hardware, cables, etc.

- The use of safety nets where structural wall panels are being erected would prevent movement of panels to point of installation. To be effective, nets would necessarily have to provide protection across the area where structural supporting wall panels would be set and plumbed before roof units could be placed.
- Use of a tower crane for the erection of the high-rise portion of the structure poses a particular hazard in that the crane operator cannot see or judge the proximity of the load in relation to the structure or nets. If the signaler is looking through nets and supporting structural devices while giving instructions to the crane operator, it is not possible to judge precise relationships between the load and the structure itself or to nets and supporting structural devices. This could cause the load to become entangled in the net or hit the structure causing potential damage.

Guardrail Systems

On this particular worksite, guardrails, barricades, ropes, cables or other perimeter guarding devices or methods on the erection floor will pose problems to safe erection procedures. Typically, a floor or roof is erected by placing 4 to 10 ft-wide structural members next to one another and welding or grouting them together. The perimeter of a floor and roof changes each time a new member is placed into position. It is unreasonable and virtually impossible to erect guardrails and toe boards at the ever changing leading edge of a floor or roof.

- To position a member safely it is necessary to remove all obstructions extending above the floor level near the point of erection. Such a procedure allows workers to swing a new member across the erected surface as necessary to position it properly without worrying about knocking material off of this surface. Hollow core slab erection on the masonry wall requires installation of the perimeter protection where the masonry wall has to be constructed. This means the guardrail is installed then subsequently removed to continue the masonry construction. The erector will be exposed to a fall hazard for a longer period of time while installing and removing perimeter protection than while erecting the slabs. In hollow core work, as in other precast concrete erection, others are not typically on the work deck until the precast concrete erection is complete. The deck is not complete until the leveling, aligning, and grouting of the joints is done. It is normal practice to keep others off the deck until at least the next day after the installation is complete to allow the grout to harden.
- There is no permanent boundary until all structural members have been placed in the floor or roof. At the leading edge, workers are operating at the temporary edge of the structure as they work to position the next member in the sequence. Compliance with the standard would require a guardrail and toe board be installed along this edge. However, the presence of such a device would prevent a new member from being swung over the erected surface low enough to allow workers to control it safely during the positioning process. Further, these employees would have to work through the guardrail to align the new member and connect it to the structure. The guardrail would not protect an employee who must lean through it to do the necessary work; rather it would hinder the employee to such a degree that a greater hazard is created than if the guardrail were absent.
- Guardrail requirements pose a hazard at the leading edge of installed floor or roof sections by creating the possibility of employees being caught between guardrails

and suspended loads. The lack of a clear work area in which to guide the suspended load into position for placement and welding of members into the existing structure creates still further hazards.

- Where erection processes require precast concrete stairways or openings to be installed as an integral part of the overall erection process, it must also be recognized that guardrails or handrails must not project above the surface of the erection floor. Such guardrails should be terminated at the level of the erection floor to avoid placing hazardous obstacles in the path of a member being positioned.

Other Fall Protection Measures Considered for This Job

The following is a list and explanation of other fall protection measures available and an explanation of limitations for use on this particular jobsite. If during the course of erecting the building the employee sees an area that could be erected more safely by the use of these fall protection measures, the foreman should be notified.

Scaffolds are not used because of the following conditions:

- The leading edge of the building is constantly changing and the scaffolding would have to be moved at very frequent intervals. Employees erecting and dismantling the scaffolding would be exposed to fall hazards for a greater length of time than they would by merely erecting the precast concrete member.
- A scaffold tower could interfere with the safe swinging of a load by the crane.
- Power lines, terrain and site do not allow for the safe use of scaffolding.

Vehicle mounted platforms are not used because of the following conditions:

- A vehicle mounted platform will not reach areas on the deck that are erected over other levels.
- The leading edge of the building is usually over a lower level of the building and this lower level will not support the weight of a vehicle mounted platform.
- A vehicle mounted platform could interfere with the safe swinging of a load by the crane, either by the crane swinging the load over or into the equipment.
- Power lines and surrounding site work do not allow for the safe use of a vehicle mounted platform.

Crane suspended personnel platforms are not used because of the following conditions:

- A second crane close enough to suspend any employee in the working and erecting area could interfere with the safe swinging of a load by the crane hoisting the product to be erected.
- Power lines and surrounding site work do not allow for the safe use of a second crane on the job.

Enforcement

Constant awareness of and respect for fall hazards, and compliance with all safety rules are considered conditions of employment. The jobsite superintendent, as well as individuals in the safety and personnel department, reserve the right to issue disciplinary warnings to employees, up to and including termination, for failure to follow the guidelines of this program.

Accident Investigations

All accidents that result in injury to workers, regardless of their nature, shall be investigated and reported. It is an integral part of any safety program that documentation take place as soon as possible so that the cause and means of prevention can be identified to prevent a reoccurrence.

In the event that an employee falls or there is some other related, serious incident occurring, this plan shall be reviewed to determine if additional practices, procedures, or training need to be implemented to prevent similar types of falls or incidents from occurring.

Changes to Plan

Any changes to the plan will be approved by (name of the qualified person). This plan shall be reviewed by a qualified person as the job progresses to determine if additional practices, procedures, or training needs to be implemented by the competent person to improve or provide additional fall protection. Workers shall be notified and trained, if necessary, in the new procedures. A copy of this plan and all approved changes shall be maintained at the jobsite.

c. Describe fall protection applicable to ladders and manlifts.

Ladders

Portable Wood Ladders

The following is taken from 29 CFR 1910.25.

All wood parts shall be free from sharp edges and splinters; sound and free from accepted visual inspection from shake, wane, compression failures, decay, or other irregularities. Low density wood shall not be used.

Stepladders shall be of three types:

- Type I—Industrial stepladder, 3 to 20 feet for heavy duty, such as utilities, contractors, and industrial use
- Type II—Commercial stepladder, 3 to 12 feet for medium duty, such as painters, offices, and light industrial use
- Type II—Household stepladder, 3 to 6 feet for light duty, such as light household use

General requirements:

- A uniform step spacing shall be employed that shall be not more than 12 inches. Steps shall be parallel and level when the ladder is in position for use.
- The minimum width between side rails at the top, inside to inside, shall be not less than 11½ inches. From top to bottom, the side rails shall spread at least 1 inch for each foot of length of stepladder.
- A metal spreader or locking device of sufficient size and strength to securely hold the front and back sections in open positions shall be a component of each stepladder. The spreader shall have all sharp points covered or removed to protect the user.

- Ladders shall be maintained in good condition at all times, the joint between the steps and side rails shall be tight, all hardware and fittings securely attached, and the movable parts shall operate freely without binding or undue play.
- Metal bearings of locks, wheels, pulleys, etc., shall be frequently lubricated.
- Frayed or badly worn rope shall be replaced.
- Safety feet and other auxiliary equipment shall be kept in good condition to ensure proper performance.
- Ladders shall be inspected frequently and those which have developed defects shall be withdrawn from service for repair or destruction and tagged or marked as “Dangerous, Do Not Use.”
- Rungs should be kept free of grease and oil.

The following safety precautions shall be observed in connection with the use of ladders:

- Portable rung and cleat ladders shall, where possible, be used at such a pitch that the horizontal distance from the top support to the foot of the ladder is one-quarter of the working length of the ladder. The ladder shall be so placed as to prevent slipping, or it shall be lashed, or held in position. Ladders shall not be used in a horizontal position as platforms, runways, or scaffolds.
- Ladders for which dimensions are specified should not be used by more than one person at a time nor with ladder jacks and scaffold planks where use by more than one person is anticipated. In such cases, specially designed ladders with larger dimensions of the parts should be procured.
- Portable ladders shall be so placed that the side rails have a secure footing. The top rest for portable rung and cleat ladders shall be reasonably rigid and shall have ample strength to support the applied load.
- Ladders shall not be placed in front of doors opening toward the ladder unless the door is blocked upon, locked, or guarded.
- Ladders shall not be placed on boxes, barrels, or other unstable bases to obtain additional height.
- Ladders with broken or missing steps, rungs, or cleats, broken side rails, or other faulty equipment shall not be used; improvised repairs shall not be made.
- Short ladders shall not be spliced together to provide long sections.
- Ladders made by fastening cleats across a single rail shall not be used.
- Ladders shall not be used as guys, braces, or skids, or for other than their intended purposes.
- Tops of the ordinary types of stepladders shall not be used as steps.
- Portable rung ladders with reinforced rails shall be used only with the metal reinforcement on the underside.
- No ladder should be used to gain access to a roof unless the top of the ladder shall extend at least 3 feet above the point of support, at eave, gutter, or roofline.
- Middle and top sections of sectional or window cleaner’s ladders should not be used for bottom section unless the user equips them with safety shoes.
- The user should equip all portable rung ladders with nonslip bases when there is a hazard of slipping. Nonslip bases are not intended as a substitute for care in safely placing, lashing, or holding a ladder that is being used upon oily, metal, concrete, or slippery surfaces.
- The bracing on the back legs of step ladders is designed solely for increasing stability and not for climbing.

Portable Metal Ladders

The following is taken from 29 CFR 1910.26.

The minimum width between side rails of a straight ladder or any section of an extension ladder shall be 12 inches.

The length of single ladders or individual sections of ladders shall not exceed 30 feet. Two-section ladders shall not exceed 48 feet in length and over two-section ladders shall not exceed 60 feet in length.

The length of a stepladder is measured by the length of the front rail. To be classified as a standard length ladder, the measured length shall be within plus or minus one-half inch of the specified length. Stepladders shall not exceed 20 feet in length.

The bottoms of the four rails are to be supplied with insulating nonslip material for the safety of the user.

A metal spreader or locking device of sufficient size and strength to securely hold the front and back sections in the open position shall be a component of each stepladder. The spreader shall have all sharp points or edges covered or removed to protect the user.

To get maximum serviceability, safety, and to eliminate unnecessary damage of equipment, good safe practices in the use and care of ladder equipment must be employed by the users. The following rules and regulations are essential to the life of the equipment and the safety of the user:

- Ladders must be maintained in good usable condition at all times.
- If a ladder is involved in any of the following, immediate inspection is necessary:
 - If ladders tip over, inspect ladder for side rails dents or bends, or excessively dented rungs; check all rung-to-side rail connections; check hardware connections; check rivets for shear.
 - If ladders are exposed to oil and grease, equipment should be cleaned of oil, grease, or slippery materials. This can easily be done with a solvent or steam cleaning.
- Ladders having defects are to be marked and taken out of service until repaired by either maintenance department or the manufacturer.

A simple rule for setting up a ladder at the proper angle is to place the base a distance from the vertical wall equal to one-fourth the working length of the ladder.

Portable ladders are designed as a one-person working ladder based on a 200-pound load.

The ladder base section must be placed with a secure footing.

The top of the ladder must be placed with the two rails supported, unless equipped with a single support attachment.

When ascending or descending, the climber must face the ladder.

Ladders must not be tied or fastened together to provide longer sections. They must be equipped with the hardware fittings necessary if the manufacturer endorses extended uses.

Ladders should not be used as a brace, skid, guy or gin pole, gangway, or for other uses than that for which they were intended, unless specifically recommended for use by the manufacturer.

Fixed Ladders

The following is taken from 29 CFR 1910.27.

All ladders, appurtenances, and fastenings shall be designed to meet the following load requirements:

- The minimum design live load shall be a single concentrated load of 200 pounds.
- The number and position of additional concentrated live-load units of 200 pounds each as determined from anticipated usage of the ladder shall be considered in the design.
- The live loads imposed by persons occupying the ladder shall be considered to be concentrated at such points as will cause the maximum stress in the structural member being considered.
- The weight of the ladder and attached appurtenances together with the live load shall be considered in the design of rails and fastenings.

Manlifts

Refer to competency statement 20a of this reference guide for a discussion of manlifts.

d. Discuss hazards of fall protection equipment, the work environment, and equipment misuse.

The following is taken from 29 CFR 1915.159.

The criteria of 29 CFR 1915.159, “Personal Fall Arrest Systems,” apply to PFASs and their use.

Criteria for Connectors and Anchorages

Connectors shall be made of drop forged, pressed, or formed steel or shall be made of materials with equivalent strength.

Connectors shall have a corrosion-resistant finish, and all surfaces and edges shall be smooth to prevent damage to the interfacing parts of the system.

D-rings and snaphooks shall be capable of sustaining a minimum tensile load of 5,000 pounds.

D-rings and snaphooks shall be proof-tested to a minimum tensile load of 3,600 pounds without cracking, breaking, or being permanently deformed.

Snaphooks shall be sized to be compatible with the member to which they are connected to prevent unintentional disengagement of the snaphook caused by depression of the snaphook keeper by the connected member, or shall be of a locking type that is designed

and used to prevent disengagement of the snap-hook by contact of the snaphook keeper by the connected member.

Snaphooks, unless of a locking type designed and used to prevent disengagement from the following connections, shall not be engaged

- directly to webbing, rope or wire rope;
- to each other;
- to a D-ring to which another snaphook or other connector is attached;
- to a horizontal lifeline; or
- to any object that is incompatibly shaped or dimensioned in relation to the snaphook such that unintentional disengagement could occur by the connected object being able to depress the snaphook keeper and release itself.

On suspended scaffolds or similar work platforms with horizontal lifelines that may become vertical lifelines, the devices used for connection to the horizontal lifeline shall be capable of locking in any direction on the lifeline.

Anchorage used for attachment of personal fall arrest equipment shall be independent of any anchorage being used to support or suspend platforms.

Anchorage shall be capable of supporting at least 5,000 pounds per employee attached, or shall be designed, installed, and used as follows:

- As part of a complete PFAS which maintains a safety factor of at least two
- Under the direction and supervision of a qualified person

Criteria for Lifelines, Lanyards, and PFASs

When vertical lifelines are used, each employee shall be provided with a separate lifeline.

Vertical lifelines and lanyards shall have a minimum tensile strength of 5,000 pounds.

Self-retracting lifelines and lanyards that automatically limit free-fall distances to 2 feet or less shall be capable of sustaining a minimum tensile load of 3,000 pounds applied to a self-retracting lifeline or lanyard with the lifeline or lanyard in the fully extended position.

Self-retracting lifelines and lanyards which do not limit free-fall distance to 2 feet or less, ripstitch lanyards and tearing and deforming lanyards shall be capable of sustaining a minimum static tensile load of 5,000 pounds applied to the device when they are in the fully extended position.

Horizontal lifelines shall be designed, installed, and used under the supervision of a qualified person, and shall only be used as part of a complete PFAS that maintains a safety factor of at least two.

Effective November 20, 1996, PFAS shall

- limit the maximum arresting force on a falling employee to 900 pounds when used with a body belt
- limit the maximum arresting force on a falling employee to 1,800 pounds when used with a body harness

- bring a falling employee to a complete stop and limit the maximum deceleration distance an employee travels to 3.5 feet
- have sufficient strength to withstand twice the potential impact energy of an employee free-falling a distance of 6 feet, or the free-fall distance permitted by the system, whichever is less

Personal fall arrest systems shall be rigged such that an employee can neither free-fall more than 6 feet nor contact any lower level.

Criteria for Selection, use and Care of Systems and System Components

Lanyards shall be attached to employees using PFASs, as follows:

- The attachment point of a body harness shall be located in the center of the wearer's back near the shoulder level, or above the wearer's head. If the free-fall distance is limited to less than 20 inches, the attachment point may be located in the chest position
- The attachment point of a body belt shall be located in the center of the wearer's back.

Ropes and straps (webbing) used in lanyards, lifelines and strength components of body belts and body harnesses shall be made from synthetic fibers or wire rope.

Ropes, belts, harnesses, and lanyards shall be compatible with their hardware.

Lifelines and lanyards shall be protected against cuts, abrasions, burns from hot work operations and deterioration by acids, solvents, and other chemicals.

Personal fall arrest systems shall be inspected prior to each use for mildew, wear, damage, and other deterioration. Defective components shall be removed from service.

Personal fall arrest systems and components subjected to impact loading shall be immediately removed from service and shall not be used again for employee protection until inspected and determined by a qualified person to be undamaged and suitable for reuse.

The employer shall provide for prompt rescue of employees in the event of a fall or shall ensure that employees are able to rescue themselves.

Body belts shall be at least one and five-eighths inches wide.

Personal fall arrest systems and components shall be used only for employee fall protection and not to hoist materials.

Training

Before using personal fall arrest equipment, each affected employee shall be trained to understand the application limits of the equipment and proper hook-up, anchoring, and tie-off techniques. Affected employees shall also be trained so that they can demonstrate the proper use, inspection, and storage of their equipment.

Mandatory Performance Activities:

- e. Complete a fall protection training course that requires hands on use and inspection of fall protection equipment or provide evidence of equivalency.**

This is a performance-based KSA. The Qualifying Official will evaluate its completion.

21. Occupational safety personnel must demonstrate a working level knowledge of hoisting and rigging protection, including programs, training requirements, hazards and elimination or control of them.

- a. Discuss the content and applicability of the DOE-STD-1090-2007, *Hoisting and Rigging Standard*.**

The following is taken from DOE-STD-1090-2007.

The versatility of hoisting and rigging equipment makes it extremely useful on construction projects. Improper and unsafe use, however, can result in serious accidents.

Chapter 15 outlines the requirements for lifting service on construction and demolition activities and provides references to other chapters of DOE-STD-1090-2007 that are applicable to the use of hoisting and rigging equipment at construction projects on DOE installations. The following chapters of DOE-STD-1090-2007 are applicable to construction hoisting and rigging operations:

- Chapter 1, Terminology and Definitions
- Chapter 2, Critical Lifts
- Chapter 4, Lifting Personnel
- Chapter 7, Overhead and Gantry Cranes
- Chapter 8, Hoists
- Chapter 9, Mobile Cranes
- Chapter 10, Forklift Trucks
- Chapter 11, Wire Rope and Slings
- Chapter 12, Rigging Accessories
- Chapter 13, Hooks
- Chapter 14, Below-the-Hook Lifting Devices
- Chapter 16, Miscellaneous Lifting Devices

- b. Identify DOE, contractor, and private organizations that develop standards and provide expertise in hoisting and rigging.**

The following descriptions, which are referenced in DOE-STD-1090-2007, are taken from the American Society for Mechanical Engineers web page.

ASME B30.2-2005

ASME B30.2-2005, *Overhead and Gantry Cranes (Top Running Bridge, Single or Multiple Girder, Top Running Trolley Hoist)*, applies to the construction, installation, operation, inspection, and maintenance of hand-operated and power-driven overhead and gantry cranes that have a top-running single-girder or multiple-girder bridge, with one or more top-running trolley hoists used for vertical lifting and lowering of freely suspended, unguided loads consisting of equipment and materials. The requirements included in this volume also apply to cranes having the same fundamental characteristics such as cantilever gantry cranes, semi-gantry cranes, and wall cranes.

ASME B30.5-2007

ASME B30.5-2007, *Mobile and Locomotive Cranes*, applies to the construction, inspection, testing, maintenance and operation of crawler cranes, locomotive cranes, wheel-mounted cranes, and any variations thereof that retain the same fundamental characteristics. The scope includes only cranes of the above types that are powered by internal combustion engines or electric motors. Side boom tractors and cranes designed for railway and automobile wreck clearance, digger derricks, cranes manufactured specifically for, or when used for, energized electrical line service, knuckle boom, trolley boom cranes, and cranes having a maximum rated capacity of one ton or less are excluded.

ASME B30.9-2010

ASME B30.9-2010, *Slings*, includes provisions that apply to the fabrication, attachment, use, inspection, and maintenance of slings used for lifting purposes, used in conjunction with equipment described in other volumes of the B30 standard. Slings fabricated from alloy steel chain, wire rope, metal mesh, synthetic fiber rope, synthetic webbing, and synthetic fiber yarns in a protective cover(s) are addressed. Slings fabricated from other materials or constructions other than those detailed in this standard shall be used only in accordance with the recommendations of the sling manufacturer or a qualified person.

ASME B30.10-2009

ASME B30.10-2009, *Hooks*, includes provisions that apply to the fabrication, attachment, use, inspection, and maintenance of hooks used for lifting and load handling purposes, in conjunction with equipment described in other volumes of the B30 standard.

ASME B30.11-2010

ASME B30.11-2010, *Monorails and Underhung Cranes*, applies to the construction, installation, operation, inspection, testing and maintenance of underhung crane and monorail systems, track sections and load-carrying members, such as end trucks or carriers that travel either on the external or internal lower flange of a track section. The track sections include single monorail track, crane bridge girders and jib booms, all curves, switches, transfer devices and lift and drop sections. Provisions apply to power driven and hand-operated equipment in which the carriers are independently controlled. Items within this scope may be referred to as equipment.

ASME B30.16-2007

ASME B30.16-2007, *Overhead Hoists (Underhung)* applies to the construction, installation, operation, inspection, testing, and maintenance of hand chain-operated chain hoists and electric and air-powered chain and wire ropes hoists used for, but not limited to, vertical lifting and lowering of freely suspended, unguided, loads which consist of equipment and materials. Requirements for a hoist that is used for a special purpose, such as, but not limited to, tensioning a load, non-vertical lifting service, lifting a guided load, lifting personnel, or drawing both the load and the hoist up or down the load chain or rope when the hoist is attached to the load, are not included in this volume.

ASME B30.17-2006

ASME B30.17-2006, *Overhead and Gantry Cranes (Top Running Bridge, Single Girder, Underhung Hoist)*, includes provisions that apply to the construction, installation, operation, inspection, and maintenance of hand-operated and power-driven overhead and

gantry cranes that have a top-running single-girder bridge, with one or more underhung hoists operating on the lower flange of the bridge girder, used for vertical lifting and lowering of freely suspended, unguided loads. The requirements included in this volume also apply to cranes having the same fundamental characteristics such as polar gantry cranes, cantilever gantry cranes, semi-gantry cranes, and wall cranes. Requirements for a crane used for a special purpose such as, but not limited to, non-vertical lifting service, lifting a guided load, or lifting personnel are not included in this volume.

ASME B30.21-2005

ASME B30.21-2005, *Manually Lever Operated Hoists*, applies to the construction, installation, operation, inspection, and maintenance of ratchet and pawl and friction brake type manually lever operated chain, wire rope, and web strap hoists used for lifting, pulling, and tensioning applications.

ASME B30.26-2010

ASME B30.26-2010, *Rigging Hardware*, applies to the construction, installation, operation, inspection, and maintenance of detachable rigging hardware used for load-handling activities in conjunction with equipment described in other volumes of the B30 standard. This hardware includes shackles, links, rings, swivels, turnbuckles, eyebolts, hoist rings, wire rope clips, wedge sockets, rigging blocks and load indication devices.

The following is taken from 29 CFR 1910.

29 CFR 1910.179

29 CFR 1910.179, "Overhead and Gantry Cranes," applies to overhead and gantry cranes, including semigantry, cantilever gantry, wall cranes, storage bridge cranes, and others having the same fundamental characteristics. These cranes are grouped because they all have trolleys and similar travel characteristics.

29 CFR 1910.180

29 CFR 1910.180, "Crawler Locomotive and Truck Cranes," applies to crawler cranes, locomotive cranes, wheel-mounted cranes of truck and self-propelled wheel type, and any variations thereof, which retain the same fundamental characteristics. This section includes only cranes of the above types, which are basically powered by internal combustion engines or electric motors and which use drums and ropes. Cranes designed for railway and automobile wreck clearances are excepted. The requirements of this section are applicable only to machines when used as lifting cranes.

29 CFR 1910.181

29 CFR 1910.181, "Derricks," applies to guy, stiffleg, basket, breast, gin pole, Chicago boom, and A-frame derricks of the stationary type, capable of handling loads at variable reaches and powered by hoists through systems of rope reeving, used to perform lifting hook work, single or multiple line bucket work, grab, grapple, and magnet work. Derricks may be permanently installed for temporary use as in construction work. The requirements of this section also apply to any modification of these types which retain their fundamental features, except for floating derricks.

29 CFR 1910.184

29 CFR 1910.184, “Slings,” applies to slings used in conjunction with other material-handling equipment for the movement of material by hoisting, in employments covered by this part. The types of slings covered are those made from alloy steel chain, wire rope, metal mesh, natural or synthetic fiber rope (conventional three strand construction), and synthetic web (nylon, polyester, and polypropylene).

c. Identify hazards related to hoisting and rigging and describe safety control measures:

- **Crane operations, including inspection, siting, operator qualification, and load limits.**
- **Use of different sling configurations and their limitations (load limits, material configuration)**
- **Explain hazard evaluation and safety controls for critical lifts.**

Crane Operations

The following is taken from the U.S. Department of Labor, Occupational Safety and Health Administration, Green Job Hazards: Wind Energy—Crane, Derrick and Hoist Safety.

Cranes, derricks, and hoists will be used to move the large, heavy loads during wind turbine installation and maintenance. Fatalities and serious injuries can occur if cranes are not inspected and used properly. Many fatalities can occur when the crane boom, load line or load contacts power lines and shorts electricity to ground. Other incidents happen when workers are struck by the load, are caught inside the swing radius or fail to assemble/disassemble the crane properly. There are significant safety issues to be considered, for the operators of the diverse lifting devices, and for workers who work near them.

- Cranes are to be operated only by qualified and trained personnel.
- A designated competent person must inspect the crane and all crane controls before use.
- Be sure the crane is on a firm/stable surface and level.
- During assembly/disassembly do not unlock or remove pins unless sections are blocked and secure (stable).
- Fully extend outriggers and barricade accessible areas inside the crane’s swing radius.
- Watch for overhead electric power lines and maintain at least a 10-foot safe working clearance from the lines.
- Inspect all rigging prior to use; do not wrap hoist lines around the load.
- Be sure to use the correct load chart for the crane’s current configuration and setup, the load weight and lift path.
- Do not exceed the load chart capacity while making lifts.
- Raise load a few inches, hold, verify capacity/balance, and test brake system before delivering load.
- Do not move loads over workers.
- Be sure to follow signals and manufacturer instructions while operating cranes.

Since wind turbines are installed in windy areas, the effects of wind speeds need to be taken into consideration for lifting activities. Stability can be an issue when the boom is high and the wind coming from the rear, front, or side of the crane can cause the load to

sway away from the crane, increasing the radius and thus possibly decreasing the crane capacity.

An employer needs to determine the wind speeds at which it is not safe to continue lifting operations. Load charts do not generally take wind speeds into consideration. If the load chart or the operating manual does not have information on wind speeds and derating information, the crane manufacturer should be consulted. The procedures applicable to the operation of the equipment, including rated capacities (load charts), recommended operating speeds, special hazard warnings, instructions, and operator's manual, must be readily available in the cab at all times for use by the operator. The maximum allowable wind speed and derating information need to be posted conspicuously in the cab or on the load chart

Extremely cold weather conditions can have an impact on crane and lifting operations. When temperatures drop below 10°F appropriate consideration should be given to crane hydraulics, and possible derating of the crane.

Bad weather such as rain, snow or fog, can also have adverse impact on lifting. Equipment and/or operations must be adjusted to address the effect of wind, ice, and snow on equipment stability and rated capacity. During thunderstorms, a crane boom can become a lightning rod. If there is an indication of possible thunderstorms, lifting activities should be suspended and the boom should be lowered to a safe position, and workers should leave the area. If the crane is struck by lightning, it should be thoroughly inspected prior to putting it back into service.

Heavy rain along with high speed winds also can affect crane operations. Water can get into components such as brakes or clutches, and render them inoperable. When these conditions exist, operators should wait until the components are dried out.

Slings

The following is taken from the U.S. Department of Labor, Occupational Safety and Health Administration, Guidance on Safe Sling Use.

This guidance will help employers and employees recognize hazardous conditions, such as

- improper sling or attachments for the type of load to be lifted and the environment in which it is being lifted;
- worn slings and attachments or those with damage such as cracks, kinks, bends, cuts, gouges, and frayed fibers; and
- improper storage of slings and misuses such as resting of loads on the sling or dragging of slings across abrasive floors.

This guidance will also help employers and employees identify and avoid hazardous work practices, such as

- riding slings or walking under suspended loads; and
- using improperly repaired or reconditioned slings and attachments or slings and attachments that must be removed from service.

There are several varieties of slings, including: alloy steel chain, wire rope, metal mesh, natural fiber rope, synthetic fiber rope, synthetic web, and synthetic round slings. Each type of sling has its advantages and disadvantages.

Many factors come into play when choosing the best sling for the task at hand. These include size, strength, flexibility, and weight, as well as suitability for the work environment, shapes of the load, and environmental conditions in which the sling will be used. A brief description of each of the six types of slings follows.

Alloy Steel Chain Slings

Alloy steel chains are often used because of their strength, durability, abrasion resistance and ability to conform to the shape of the loads on which they are used. In addition, these slings are able to lift hot materials.

Alloy steel chain slings are made from various grades of alloy, but the most common grades in use are grades 80 and 100. These chains are manufactured and tested in accordance with ASTM guidelines.

Wire Rope Slings

Wire rope is often used in slings because of its strength, durability, abrasion resistance and ability to conform to the shape of the loads on which it is used. In addition, wire rope slings are able to lift hot materials.

Wire rope used in slings can be made of ropes with either independent wire rope core or a fiber core. It should be noted that a sling manufactured with a fiber core is usually more flexible but is less resistant to environmental damage. Conversely, a core that is made of a wire rope strand tends to have greater strength and is more resistant to heat damage.

Metal Mesh Slings

Metal mesh slings are widely used in metalworking and in other industries where loads are abrasive, hot, or will tend to cut web slings. Unlike nylon and wire rope slings, metal mesh slings resist abrasion and cutting. Metal mesh slings grip the load firmly without extensive stretching, easily maintaining balanced loads. Uncoated metal mesh slings withstand temperatures up to 550°F.

Metal mesh slings combine alloy steel fittings joined to the steel mesh. Fittings are sometimes plated for protection and better visibility. Metal mesh slings have the following properties:

- Smooth, flat bearing surfaces
- Carbon steel mesh that resists corrosion and abrasion
- Flexible mesh that conforms to irregular shapes

Materials other than carbon steel are available for metal mesh slings, such as alloy steel for higher-rated loads and stainless steel for corrosive environments.

Natural and Synthetic Fiber Rope Slings

Natural and synthetic fiber rope slings are used primarily for temporary work, such as construction and painting jobs, and in marine operations. Fiber rope slings are pliant, grip loads well, and do not mar the surface of the load.

The most common constructions for fiber rope slings are 3-strand laid, 8-strand plaited, and hollow braided nylon and polyester. Fiber rope slings have the following properties in common:

- Strength
- Safety
- Convenience
- Load protection
- Long life
- Economy
- Shock absorbency
- Temperature resistance

Synthetic Web Slings

Synthetic web slings offer a number of advantages for rigging purposes. The most commonly used synthetic web slings are made of nylon-or polyester-type yarns. They have the following properties in common:

- Strength
- Convenience
- Load protection
- Economy

Each synthetic material has its own unique properties.

Certain synthetic materials perform better than others in specific applications and environments. Consult the sling manufacturer or a qualified person for a specific application or before using in and around chemical environments.

Synthetic webbing materials other than nylon and polyester are also used and the manufacturer should be consulted for specific data for proper use.

Synthetic Round Slings

Synthetic round slings offer a number of advantages for rigging purposes. The most commonly used synthetic round slings are made of nylon- or polyester-type yarns. They have the following properties in common:

- Strength
- Convenience
- Load protection
- Economy

Each synthetic material has its own unique properties. Certain synthetic materials perform better than others in specific applications and environments. Consult the sling manufacturer or a qualified person for a specific application or before using in and around chemical environments.

Some round slings are manufactured using materials other than nylon or polyester; consult the manufacturer for the proper selection, use, maintenance, and any hazards associated with their use.

Critical Lifts

The following is taken from DOE-STD-1090-2007.

Critical Lift Determination

An appointed person shall classify each lift into one of the DOE categories (ordinary, critical, or pre-engineered production) prior to planning the lift.

A lift shall be designated critical if any of the following conditions are met:

- The load item, if damaged or upset would result in a release into the environment of radioactive or hazardous material exceeding the established permissible environmental limits.
- The load item is unique and, if damaged, would be irreplaceable or not repairable and is vital to a system, facility or project operation.
- The cost to replace or repair the load item, or the delay in operations of having the load item damaged would have a negative impact on facility, organizational, or DOE budgets to the extent that it would affect program commitments.
- A lift not meeting the above criteria shall also be designated critical if mishandling or dropping of the load would cause any of the above noted consequences to nearby installations or facilities.

Further site-specific criteria may be developed to supplement those cited above and may include loads that require exceptional care in handling because of size, weight, close-tolerance installation or high susceptibility to damage as well as lifts using multiple pieces of lifting equipment.

Critical Lift Requirements

Ensure that the requirements are met for ordinary lifts specified in each section of DOE-STD-1090-2007 for each particular equipment category.

The operating organization shall appoint a person-in-charge (PIC) for the entire operation. This person shall meet the definitions of appointed, designated, and qualified, and shall be present at the lift site during the entire lifting operation.

The PIC shall ensure that a pre-job plan or procedure is prepared that defines the operation and includes the following:

- Identification of the items to be moved, the weight, dimensions, and center of gravity of the load, and any hazardous or toxic materials that are present
- Identification of operating equipment to be used by type and rated capacity
- Rigging sketches that include the following (as applicable):
 - Identification and rated capacity of slings, lifting bars, rigging accessories, and below-the-hook lifting devices—calculate and provide the rated capacity of equipment in the configuration in which it will be used
 - Load-indicating devices
 - Load vectors
 - Lifting points
 - Sling angles
 - Boom and swing angles
 - Methods of attachment
 - Crane orientations

- Other factors affecting equipment capacity
- Operating procedures and special instructions to operators, including rigging precautions and safety measures to be followed as applicable

All rigging equipment used in critical lifts shall have proof load certificates.

Experienced operators who have been trained and qualified to operate the specific equipment to be used shall be assigned to make the lift.

Only designated, qualified signalers shall give signals to the operator. However, the operator shall obey a STOP signal at all times, no matter who gives the signal.

The procedure and rigging sketches shall be reviewed and approved by the responsible manager and the responsible oversight organization before the lift is made. Subsequent revisions shall be approved per site specific procedures.

A pre-lift meeting involving participating personnel shall be conducted prior to making a critical lift. The critical lift plan/procedure shall be reviewed and questions shall be resolved.

If required by the critical lift procedure, a practice lift shall be done before the critical lift. Conditions for a practice lift should closely simulate actual conditions involving: weight, rigging selection and configuration, load movement path, and other relevant factors. Practice lifts should be done by the same crew, using the same lifting equipment.

Although individual plans are generally prepared for critical lifts, multi-use plans may be employed to accomplish recurrent critical lifts.

- d. Define the following hazards and describe controls used with hoisting and rigging equipment and operations:**
- **Crane load tests and inspection requirements**
 - **Effects of boom angle and length on load limits**
 - **Major signs of stress, strain, or other deterioration that must be evaluated when inspecting rigging equipment**
 - **Overhead power lines and other environmental and conditions hazards**
 - **Appropriate lifting techniques and limitations, including the relationship between the crane operator and the spotter**

Crane Load Tests and Inspection Requirements

The following is taken from 29 CFR 1910.179.

Tests

Prior to initial use all new and altered cranes shall be tested to ensure compliance with 29 CFR 1910.179, including the following functions:

- Hoisting and lowering
- Trolley travel
- Bridge travel
- Limit switches, locking and safety devices

The trip setting of hoist limit switches shall be determined by tests with an empty hook traveling in increasing speeds up to the maximum speed. The actuating mechanism of the limit switch shall be located so that it will trip the switch, under all conditions, in sufficient time to prevent contact of the hook or hook block with any part of the trolley.

Rated load test. Test loads shall not be more than 125 percent of the rated load unless otherwise recommended by the manufacturer. The test reports shall be placed on file where readily available to appointed personnel.

Inspections

Prior to initial use all new and altered cranes shall be inspected to ensure compliance with 29 CFR 1910.179. Inspection procedure for cranes in regular service is divided into two general classifications based on the intervals at which inspection should be performed. The intervals in turn are dependent on the nature of the critical components of the crane and the degree of their exposure to wear, deterioration, or malfunction. The two general classifications are frequent and periodic with respective intervals between inspections as defined below:

- Frequent inspection—daily to monthly intervals
- Periodic inspection—1 to 12-month intervals

Frequent inspection. The following items shall be inspected for defects at intervals as defined in 29 CFR 1910.179, or as specifically indicated, including observation during operation for any defects which might appear between regular inspections. All deficiencies such as listed shall be carefully examined and determination made as to whether they constitute a safety hazard:

- All functional operating mechanisms for maladjustment interfering with proper operation. Daily.
- Deterioration or leakage in lines, tanks, valves, drain pumps, and other parts of air or hydraulic systems. Daily.
- Hooks with deformation or cracks. Visual inspection daily; monthly inspection with a certification record that includes the date of inspection, the signature of the person who performed the inspection, and the serial number, or other identifier, of the hook inspected.
- Hoist chains, including end connections, for excessive wear, twist, distorted links interfering with proper function, or stretch beyond manufacturer's recommendations. Visual inspection daily; monthly inspection with a certification record that includes the date of inspection, the signature of the person who performed the inspection, and an identifier of the chain which was inspected.
- All functional operating mechanisms for excessive wear of components.
- Rope reeving for noncompliance with manufacturer's recommendations.

Periodic inspection. Complete inspections of the crane shall be performed at intervals as generally defined in 29 CFR 1910.179 depending on its activity, severity of service, and environment, or as specifically indicated below. These inspections shall include the requirements of 29 CFR 1910.179 and in addition, the following items. Any deficiencies such as listed shall be carefully examined and determination made as to whether they constitute a safety hazard:

- Deformed, cracked, or corroded members
- Loose bolts or rivets

- Cracked or worn sheaves and drums
- Worn, cracked or distorted parts such as pins, bearings, shafts, gears, rollers, locking and clamping devices
- Excessive wear on brake system parts, linings, pawls, and ratchets
- Load, wind, and other indicators over their full range, for any significant inaccuracies
- Gasoline, diesel, electric, or other power plants for improper performance or noncompliance with applicable safety requirements
- Excessive wear of chain drive sprockets and excessive chain stretch.
- Electrical apparatus, for signs of pitting or any deterioration of controller contactors, limit switches and pushbutton stations

Effects of Boom Angle and Length on Load Limits

The following is taken from Integrated Publishing, Engine Mechanics, Boom Angle Indicators.

Boom angle indicators are normally mounted on the boom butt, visually readable by the operator. On most models in the naval construction force, the boom angle indicator is a metal plate with degree numbers (0 to 90 degrees) and a freely swinging arm that reacts as the boom angle changes (see figure 8).

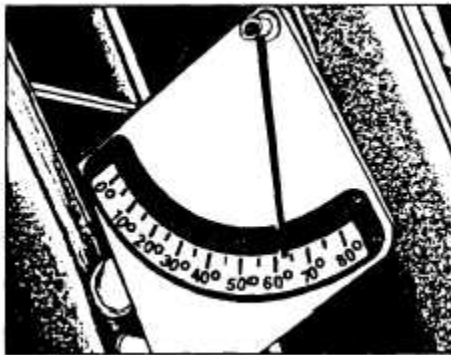

Source: Integrated Publishing, Engine Mechanics, Boom Angle Indicators

Figure 8. Boom angle indicator

The numbers and arm should remain clean and visually readable at all time. The capacities that are listed on the crane load charts are also based on and vary with the boom angle of the crane. On hydraulic cranes, the boom angle is the angle between the bottom of the boom butt and the horizontal while the boom is under load. The boom angle on lattice boom cranes is the angle between the center line of the boom and the horizontal while the boom is under load.

To check the accuracy of the boom angle indicator, place a 3-foot builder's level on the center boom section and raise or lower the boom until the level indicates the boom is level. At this point the boom angle indicator should show the boom is a zero degrees or adjusted to read zero degrees.

The boom angle indicator is a quick reference for the operator to know what angle the boom is at.

Major Signs of Stress, Strain or Other Deterioration

The following is taken from SLAC National Accelerator Laboratory, Inspection Criteria for Rigging Accessories and Wire Rope and Slings per DOE-STD-1090-2007.

This inspection criterion is intended to cover operator pre-use inspections only. It does not cover the qualified inspector's initial and period inspections. It does not cover operational requirements, proof testing, care, maintenance or storage. These issues are detailed in the appropriate sections of DOE-STD-1090-2007 and should be reviewed by the operator prior to use.

Rigging Hooks

The manufacturer's identification shall be forged, cast, or die-stamped on a low-stress and non-wearing area of the hook.

The operator or other designated person shall visually inspect hooks daily or prior to first use, if the hook is not in regular service, for the following:

- Cracks, nicks, gouges
- Deformation
- Damage from chemicals
- Damage, engagement, or malfunction of latch (if provided)
- Evidence of heat damage
- Wear
- Hook attachment and securing means

Shackles

Each shackle body shall be permanently and legibly marked by the manufacturer.

Raised or stamped letters on the side of the bow shall be used to show

- manufacturer's name or trademark
- size
- rated capacity, recommended safe working load

Grade A shackles (regular strength), together with their pins and bolts shall be forged from carbon steel.

Grade B shackles (high strength) together with their pins and bolts shall be forged from alloy steel.

Shackle pins shall fit freely without binding and seat properly.

Eyebolts

Eyebolts used for hoisting shall be fabricated from forged carbon or alloy steel.

Eyebolt marking:

- Carbon steel eyebolts shall have the manufacturer's name or identification trademark forged in raised characters on the surface of the eyebolt.
- Alloy steel eyebolts shall have the symbol "A" (denoting alloy steel) and the manufacturer's name or identification mark forged in raised characters on the surface of the eyebolt.

Carefully inspect each eyebolt before use.

Visually inspect the hole to ensure that there has been no deformation.

Check the condition of the threads in the hole to ensure that the eyebolt will secure and the shoulder can be brought down snug.

Destroy eyebolts that are cracked, bent, or have damaged threads.

Ensure that the shank of the eyebolt is not undercut and is smoothly radiused into the plane of the shoulder or the contour of the ring for non-shouldered eyebolts.

Turnbuckles

Turnbuckles may be used in sling systems provided that they are engineered, designed, and approved as a part of the sling system. Approved turnbuckles shall be marked and identified for use with the sling set for which they were designed and shall be load-tested as part of the sling set.

Before each use, turnbuckles shall be inspected for damage. Damaged threads, jamb nuts, or bent frame members make the unit unsuitable for use.

Turnbuckles shall be fabricated from forged alloy steel.

Turnbuckles shall be provided with a jam nut of a type which does not depend upon deformation of the threads for security.

Manufacturer's name or trademark and turnbuckle size shall be permanently marked on the body of the turnbuckle.

Links and Rings

Links and rings are usually designed and manufactured as a part of the lifting hardware for a specific purpose, such as the peak link on multiple-leg slings. However, the rings and links may also be found on the load-attachment end of slings.

Welded rings or links shall be subjected to a nondestructive test (NDT) and have documentation provided. Note: NDT is not required for forged rings or links.

Rings shall be forged or welded from low alloy steel.

Rings or links should be marked by the manufacturer with the manufacturer's name or trademark and ring or link size.

Swivel Hoist Rings

Swivel hoist rings for hoisting shall be fabricated from forged carbon or alloy steel.

Swivel hoist rings shall have the manufacturer's name or trademark, working load limit, and recommended torque value permanently marked by the manufacturer on the swivel hoist ring. Permanently attached metal tag bearing the same information may also be used.

Carefully inspect each swivel hoist ring before use.

Visually inspect the hole to ensure that there has been no deformation.

Check the condition of the threads in the hole to ensure that the hoist ring will secure and the bushing can be brought down snug.

Destroy hoist rings that are cracked, bent, have damaged threads, or do not operate freely.

Permanently installed hoist rings shall be inspected before each use to ensure free movement of bail and swivel.

Wire Rope Sling

Wire-rope sling users shall visually inspect all slings each day they are used or prior to use if the sling has not been in regular service (records are not required).

Users shall carefully note any deterioration that could result in an appreciable loss of original strength and determine whether further use of the sling would constitute a safety hazard.

Slings shall be immediately removed from service if any of the following conditions are present:

- Ten randomly distributed broken wires in one rope lay or five broken wires in one strand in one rope lay
- Wear or scraping of one-third the original diameter of the outside individual wire
- Kinking, crushing, bird caging or any other damage resulting in distortion of the rope structure
- Evidence of heat damage
- End attachments that are cracked, deformed, or worn
- Corrosion of the rope or end attachments
- Missing or illegible sling identification

Wire-rope slings shall be marked with the manufacturer's name, ID or trademark, rated capacity for the type of hitch(es), working load limit, purchase order number or serial number, diameter or size, evidence of periodic inspection date. Sling identification should be maintained by the user so as to be legible during the life of the sling.

Wire rope purchased to fabricate slings shall be made in the United States by a member of Wire Rope Technical Board. Stainless steel wire rope shall be made in the United States and shall be 302 or 304 grade stainless steel.

Wire Rope Clips (Clamps)

Shall be permanently and legibly marked with the size and manufacturer's identifying mark.

Alloy Steel-Chain Slings

This section applies to slings made from grade 80 and 100 alloy chain manufactured and tested in accordance with National Association of Chain Manufacturers welded steel chain specifications—1990. If chain other than this is used, it shall be used in accordance with the recommendations of the chain manufacturer.

Steel-chain sling users shall visually inspect all slings before they are used as follows:

- Conduct a link-by-link inspection for the following defects: nicks, cracks, gouges, wear, bent links, stretched links, shearing of links, cracks in any section of link, scores, abrasions, heat damage, rust, corrosion or markings tending to weaken the links. Reject if discovered.
- Check steel-chain slings for uneven lengths when sling legs are hanging free.
- Check rings and hooks for bends, distortion, cracks in weld areas, corrosion, and scores, heat damage, or markings tending to weaken the links. Reject if discovered.
- Perform inspection on an individual-link basis. If any link does not hinge freely with the adjoining link, remove the assembly from service.
- Remove from service assemblies with deformed master links or coupling links.
- Remove from service assemblies if hooks have been opened more than 15 percent of the normal throat opening measured at the narrowest point or twisted more than 10 degrees from the plane of the unbent hook.
- Do not straighten deformed hooks or other attachments on the job. Assemblies with such defects shall be reconditioned by the manufacturer or discarded.
- Remove from service assemblies with cracked hooks or other end attachments; assemblies with such defects shall be reconditioned or repaired prior to return to service.
- Do not use homemade links, makeshift fasteners formed from bolts, rods, and the like, or other nonstandard attachments. Reject if discovered.
- Do not use makeshift or field-fabricated hooks on steel-chain slings. Reject if discovered.

Ensure that steel-chain slings used are permanently marked with size, manufacturer's grade, rated load and angle on which the rating is based, reach, number of legs, sling manufacturer and inspection due date. This information may be stenciled or stamped on a metal tag or tags affixed to the sling.

Metal-Mesh Slings

Users of metal-mesh sling shall visually inspect all metal-mesh slings before each use.

Metal-mesh slings shall be removed from service if any of the following defects are present:

- A broken weld or brazed joint along the sling edge
- A broken wire in any part of the mesh
- Reduction in wire diameter of 25 percent due to abrasion or 15 percent due to corrosion
- Lack of flexibility due to distortion of the mesh
- Distortion of the female handle so the depth of the slot is increased by more than 10 percent
- Distortion of either end fitting so the width of the eye opening is decreased by more than 10 percent
- A 15 percent reduction of the original cross-sectional area of metal at any point around a handle eye
- Any distortion or twisting of either end fitting out of its plane
- Cracked end fitting
- Evidence of heat damage

Synthetic-Web Slings

Users of synthetic-web sling shall visually inspect all slings before each use.

Slings shall be removed from service if any of the following defects are visible:

- Acid or caustic burns
- Melting or charring of any part of the surface
- Snags, punctures, tears, or cuts
- Broken or worn stitches
- Wear or elongation exceeding the amount recommended by the manufacturer
- Distortion of fittings
- Knots in any part
- Missing or illegible sling identification

Ensure that each sling is permanently marked to show:

- Name or trademark of manufacturer
- Manufacturer's code or stock number
- Rated capacity for types of hitches used
- Type of synthetic-web material

Hand written, or ink embossed markings are not acceptable. Sling tags shall be indelibly marked and the lettering shall not wear off with use. The markings shall remain legible for the life of the sling.

Synthetic Round Slings

Users of synthetic round slings shall visually inspect all slings before each use.

Each polyester round sling shall be permanently marked or labeled showing:

- Name or trademark of manufacturer
- Manufacturer's code or stock number
- Rated capacities for the three basic hitches (vertical, choker, vertical basket)
- Core fiber type—if cover(s) is of a different fiber type, both fiber types shall be identified
- Length (reach)—bearing point to bearing point

Each manufacturer shall internally identify their product with name or trademark for traceability.

Slings shall be removed from service if any of the following defects are visible:

- Acid or caustic burns
- Melting or charring of any part of the surface
- Snags, punctures, tears, cuts or abrasive wear that expose the core yarns
- Broken or worn stitches in the cover which exposes the core yarns
- Wear or elongation exceeding the amount recommended by the manufacturer
- Stretched, cracked, worn, pitted or distortion of fittings
- Knots in any part
- Missing or illegible sling identification

Overhead Power Lines

The following is taken from the U.S. Department of Labor, Occupational Safety and Health Administration, Overhead Power Line Safety Tips for the Construction Industry.

Safety tips for working with overhead power lines include the following:

- Develop and implement written safety programs to help workers recognize and control the hazards of contact with overhead power lines.
- Conduct initial and daily surveys of the worksite and implement control measures and training to address hazards at the site.
- A successful defense against electrical accidents is the continuous exercising of good judgment or common sense. All employees should be thoroughly familiar with the safety procedures for their particular jobs. When work is performed on electrical equipment, for example, some basic procedures are:
 - Have the equipment de-energized.
 - Ensure that the equipment remains de-energized by using some type of lockout and tag procedure.
 - Use grounding lines when they are required.
 - Use insulating equipment.
 - Keep a safe distance from energized parts.
- Don't operate equipment around overhead power lines unless you are authorized and trained to do so.
- If an object (scaffolds, crane, etc.) must be moved in the area of overhead power lines, appoint a competent worker whose sole responsibility is to observe the clearance between the power lines and the object. Warn others if the minimum distance is not maintained.
- Never touch an overhead line if it has been brought down by machinery or has fallen. Never assume lines are dead.
- When a machine is in contact with an overhead line, **DO NOT** allow anyone to come near or touch the machine. Stay away from the machine and summon outside assistance.
- Never touch a person who is in contact with a live power line.
- Be trained in cardiopulmonary resuscitation.
- If you should be in a vehicle that is in contact with an overhead power line, **DON'T LEAVE THE VEHICLE**. As long as you stay inside and avoid touching metal on the vehicle, you may avoid an electrical hazard. If you need to get out to summon help or because of fire, jump out without touching any wires or the machine, keep your feet together, and hop to safety.
- When mechanical equipment is being operated near overhead power lines, employees standing on the ground may not contact the equipment unless it is located so that the required clearance cannot be violated even at the maximum reach of the equipment.
- To maximize his or her own safety, an employee should always use tools that work properly. Tools must be inspected before use and, those found questionable, removed from service and properly tagged. Tools and other equipment should be regularly maintained. Inadequate maintenance can cause equipment to deteriorate, resulting in an unsafe condition.

- Tools that are used by employees to handle energized conductors must be designed and constructed to withstand the voltages and stresses to which they are exposed.
- Use the PPE appropriate for the job that is performed. This equipment may consist of rubber insulating gloves, hoods, sleeves, matting, blankets, etc. These items must be inspected prior to each use and tested annually.
- When working near overhead power lines, the use of non-conductive wooden or fiberglass ladders is recommended. Aluminum ladders and metal scaffolds or frames are efficient conductors of electricity.
- Avoid storing materials under or near overhead power lines.

Appropriate Lifting Techniques

The following is taken from eHow, How to Use a Spotter for Moving Cranes & Heavy Equipment.

Moving cranes and other heavy equipment is a dangerous proposition if you are not careful at all times. Because the crane operator is so far removed from the ground and the load, he cannot see any obstacles that may be in the way. The spotter helps spot for the operator by keeping a watch for any problems and radioing instructions to the crane operator.

Equip all the workers in the construction zone with safety vests, including the spotter and the crane operator. The traffic vests allow for both the operator and the spotter to easily see any worker in reduced visibility environments like rain or snow. They are also required by OSHA regulations and by many state laws whenever large cranes are used. Have all the workers also wear hard hats to protect them from being hit by debris from a crash, the carried load or the crane itself. Hard hats are also required by OSHA at worksites. If in an enclosed cabin, the crane operator can dispense with a hard hat to give himself larger sight lines. Everyone should also be equipped with steel-toed shoes as a general precaution against falling debris from a crash.

Equip the spotter and the crane operator with their own dedicated two-way radios. No one else is to get on this radio channel though the crane operator should have the party channel open on the crane's built-in radio. The party channel serves as both an emergency backup and as a connection for the other workers to talk with the crane operator if need be. The two-way radio allows for the spotter to constantly talk to the crane operator, advising the ground conditions in front of the crane as well as the exact position of the carried load.

Clear the path that the crane will travel beforehand. There should be six feet of clearance on either side of the path in case the crane needs to deviate from its planned route slightly. If the ground is wet from rain or other precipitation, then spread gravel over the path to give the crane better traction. If the ground is so wet that it is runny mud, then cancel the move. The spotter has the final say as to whether the crane should proceed or not, as the spotter has the closest view of the ground conditions. During the move, the spotter should constantly relay information to the crane operator until the crane has finalized its move.

Communicate in clear commands, of which only the spotter should give commands to the crane operator. The spotter should always give approximate measurements to all his

commands, for example: “Go forward 30 yards.” All commands should be given from the perspective of the crane operator. Left is the operator’s left, not the spotter’s left. The spotter finishes his command by saying “Over” and the crane operator does not follow the command he hears the spotter say this. The spotter can at any time say “Full stop” and the crane operator immediately halts his movement and awaits command. The crane operator has the discretion to also stop at any time if he feels the command is unsafe.

e. Explain how suspect/counterfeit items programs affect safe hoisting and rigging.

The following is taken from the Thomas Jefferson National Accelerator Facility, Suspect/Counterfeit Item Awareness.

Suspect/counterfeit items in the workplace can

- cause an unsafe condition that puts people at risk of injury or death
- cause a spill or release to the environment
- cause extensive damage to equipment
- cause delays that impact project schedules and cost
 - Equipment can’t be used until concern is resolved.
 - Reporting requirements to operating experience summary.
 - Engineering evaluation may need to be performed.
 - Material containing suspect/counterfeit items must be segregated and cannot be returned to the supplier/contractor.

f. Describe lessons learned from DOE fall protection accidents presented in ORPS reports.

This is a site-specific, performance-based KSA. The Qualifying Official will evaluate its completion.

22. Occupational safety personnel must demonstrate a familiarity level knowledge of ergonomic and human factors engineer hazards and their elimination or control.

a. Discuss basic ergonomics terminology.

The following is taken from the WorkRite Ergonomics, Glossary of Ergonomic Terms.

Table 21. Terms related to ergonomics

Term	Definition
Musculoskeletal disorders (MSDs)	This includes a number of injuries to muscles, tendons, ligaments, nerves, joints, bones, and supporting blood vessels in the upper or lower extremities or back. These conditions are caused by ergonomic hazards in the workplace such as awkward positioning, repetition, force, mechanical compression, vibration and duration of operation. MSDs result from the cumulative effect of repeated trauma to a particular part of the body.
Anthropometry	The study of physical dimensions in people, including the measurement of human body characteristics such as size, breadth, girth, and distance between anatomical points. Also includes segment masses, the centers of gravity of body segments, and the ranges of joint motion, which are used in biomechanical analyses of work postures.
Awkward posture	A deviation from the neutral position of any particular joint.
Administrative controls	Any procedure that significantly limits daily exposure by control or manipulation of the work schedule or manner in which work is performed. Administrative controls

Term	Definition
	include, but are not limited to, job rotation, use of rest breaks or alternative tasks, job enlargement to increase task variability, redesign of work methods, and adjustment of work pace or number of repetitions. Use administrative controls to limit the duration, frequency, and severity of exposure to work-related MSD hazards. Administrative controls include <ul style="list-style-type: none"> ▪ reducing the number and speed of repetitions by reducing line or production speed or by having worker input regarding production speed; ▪ limiting overtime work and modifying production rate requirements to reduce the number of repetitions; ▪ providing rest breaks to relieve fatigued muscle-tendon groups; ▪ increasing the number of personnel assigned to the task; ▪ instituting job rotation as a preventive measure, with the goal of alleviating physical fatigue and stress to a particular set of muscles and tendons; and ▪ providing modified- or restricted-duty assignments to allow injured muscle-tendon groups time to rest.
Personal protective equipment	PPE is not necessarily recommended for controlling exposure to work-related MSD hazards, since little research has been conducted to support claims of its usefulness. Appliances, such as wrist rests, back belts, back braces, and so on, are not considered PPE.
Cumulative trauma disorder (CTD)	CTD is a bodily injury associated with repeated biomechanical stress over time.
Dynamics	The biomechanical aspects of the human body in motion.
Engineering controls	Physical changes to work stations, equipment, materials, production facilities, or any other relevant aspect of the work environment that reduce or prevent exposure to risk factors.
Ergonomics	A discipline that involves fitting the job to the worker and not the worker to the job. It is the science of adapting workstations, tools, equipment, and job practices to be compatible with the individual worker and thus reduce the risk of injury due to risk factors.
Neutral position	The body position that minimizes stresses on the body. Typically the neutral posture will be near the mid-range of any joint's range of motion.
Pacing	Controlling an employee's rate of movement through external means, such as a continuous conveyor moving at a fixed speed, production pressure, peer pressure, or pay incentives.
Pronation	The action of rotating the forearm so that the hand is palm down.
Tendonitis	Tendons connect muscles to bones. Tendonitis is the result of the inflammation of tendons at a body part.
Ulnar deviation	Bending the wrist towards the little finger side.
Vibration	The oscillatory motion of a physical body.
Work cycle	The work cycle consists of an exertion period and a recovery (or smaller exertion) period necessary to complete one sequence of a task, before the sequence is repeated.
Work methods	The physical methods used to perform the tasks of a job, such as reaching, gripping, using tools and equipment, or discarding objects.
Work recovery cycle	The job pattern that defines how work is organized with respect to lighter tasks or rest. High work/recovery ratios, measured as continuous time on each type of activity, have higher potential for fatigue.

Source: WorkRite Ergonomics, Glossary of Ergonomic Terms

b. Describe ergonomic considerations that must be addressed when evaluating new or existing jobs, processes, or operations, and identify appropriate methods for the elimination or control of ergonomic hazards.

The following is taken from NIOSH Publication No. 97-117, Elements of Ergonomics Programs.

Ergonomics focuses on the interactions between work demands and worker capabilities. The goal is to achieve those interactions between the work and the worker that will optimize productivity and, at the same time, preserve the safety and health of the workforce. These principles can aid employers in reducing the risk of work-related MSDs.

General Workstation Design Principles

General workstation design principles include the following:

- Make the workstation adjustable, enabling both large and small persons to fit comfortably and reach materials easily.
- Locate all materials and tools in front of the worker to reduce twisting motions.
- Provide sufficient work space for the whole body to turn.
- Avoid static loads, fixed work postures, and job requirements in which operators must frequently or for long periods
 - lean to the front or the side
 - hold a limb in a bent or extended position
 - tilt the head forward more than 15 degrees
 - support the body's weight with one leg
- Set the work surface above elbow height for tasks involving fine visual details and below elbow height for tasks requiring downward forces and heavy physical effort.
- Provide adjustable, properly designed chairs with the following features:
 - Adjustable seat height
 - Adjustable up and down back rest, including a lumbar (lower-back) support
 - Padding that will not compress more than an inch under the weight of a seated individual and
 - Chair that is stable to floor at all times (5-leg base)
- Allow the workers, at their discretion, to alternate between sitting and standing.
- Provide floor mats or padded surfaces for prolonged standing.
- Support the limbs: provide elbow, wrist, arm, foot, and back rests as needed and feasible.
- Use gravity to move materials.
- Design the workstation so that arm movements are continuous and curved. Avoid straight-line, jerking arm motions.
- Design so arm movements pivot about the elbow rather than around the shoulder to avoid stress on shoulder, neck, and upper back.
- Design the primary work area so that arm movements or extensions of more than 15 inches are minimized.
- Provide dials and displays that are simple, logical, and easy to read, reach, and operate.
- Eliminate or minimize the effects of undesirable environmental conditions such as excessive noise, heat, humidity, cold, and poor illumination.

Design Principles for Repetitive Hand and Wrist Tasks

Design principles for repetitive hand and wrist tasks include the following:

- Reduce the number of repetitions per shift. Where possible, substitute full or semi-automated systems.

- Maintain neutral (handshake) wrist positions:
 - Design jobs and select tools to reduce extreme flexion or deviation of the wrist.
 - Avoid inward and outward rotation of the forearm when the wrist is bent to minimize elbow disorders (i.e., tennis elbow).
- Reduce the force or pressure on the wrists and hands:
 - Wherever possible, reduce the weight and size of objects that must be handled repeatedly.
 - Avoid tools that create pressure on the base of the palm which can obstruct blood flow and nerve function.
 - Avoid repeated pounding with the base of the palm.
 - Avoid repetitive, forceful pressing with the finger tips.
- Design tasks so that a power rather than a finger pinch grip can be used to grasp materials. Note that a pinch grip is five times more stressful than a power grip.
- Avoid reaching more than 15 inches in front of the body for materials:
 - Avoid reaching above shoulder height, below waist level, or behind the body to minimize shoulder disorders.
 - Avoid repetitive work that requires full arm extension (i.e., the elbow held straight and the arm extended).
- Provide support devices where awkward body postures (elevated hands or elbows and extended arms) must be maintained. Use fixtures to relieve stressful hand/arm positions.
- Select power tools and equipment with features designed to control or limit vibration transmissions to the hands, or alternatively design work methods to reduce time or need to hold vibrating tools.
- Provide for protection of the hands if working in a cold environment. Furnish a selection of glove sizes and sensitize users to problems of forceful overgripping when worn.
- Select and use properly designed hand tools (e.g., grip size of tool handles should accommodate the majority of workers).

Hand tool Use and Selection Principles

Hand tool use and selection principles include the following:

- Maintain straight wrists. Avoid bending or rotating the wrists. Remember, bend the tool, not the wrist. A variety of bent-handle tools are commercially available.
- Avoid static muscle loading. Reduce both the weight and size of the tool. Do not raise or extend elbows when working with heavy tools. Provide counter-balanced support devices for larger, heavier tools.
- Avoid stress on soft tissues. Stress concentrations result from poorly designed tools that exert pressure on the palms or fingers. Examples include short-handled pliers and tools with finger grooves that do not fit the worker's hand.
- Reduce grip force requirements. The greater the effort to maintain control of a hand tool, the higher the potential for injury. A compressible gripping surface rather than hard plastic may alleviate this problem.
- Whenever possible, select tools that use a full-hand power grip rather than a precision finger grip.
- Maintain optimal grip span. Optimum grip spans for pliers, scissors, or tongs, measured from the fingers to the base of the thumb, range from 6 to 9 centimeters

(cm). The recommended handle diameters for circular-handle tools such as screwdrivers are 3 to 5 cm when a power grip is required, and 0.75 to 1.5 cm when a precision finger grip is needed.

- Avoid sharp edges and pinch points. Select tools that will not cut or pinch the hands even when gloves are not worn.
- Avoid repetitive trigger-finger actions. Select tools with large switches that can be operated with all four fingers. Proximity switches are the most desirable triggering mechanisms.
- Isolate hands from heat, cold, and vibration. Heat and cold can cause loss of manual dexterity and increased grip strength requirements. Excessive vibration can cause reduced blood circulation in the hands causing a painful condition known as white finger syndrome.
- Wear gloves that fit. Gloves reduce both strength and dexterity. Tight-fitting gloves can put pressure on the hands, while loose-fitting gloves reduce grip strength and pose other safety hazards (e.g., snagging).

Design Principles for Lifting and Lowering Tasks

Design principles for lifting and lowering tasks include the following:

- Optimize material flow through the workplace by
 - reducing manual lifting of materials to a minimum;
 - establishing adequate receiving, storage, and shipping facilities; and
 - maintaining adequate clearances in aisle and access areas.
- Eliminate the need to lift or lower manually by
 - increasing the weight to a point where it must be mechanically handled;
 - palletizing handling of raw materials and products; and
 - using unit load concept (bulk handling in large bins or containers).
- Reduce the weight of the object by
 - reducing the weight and capacity of the containers;
 - reducing the load in the container; and
 - limiting the quantity per container to suppliers.
- Reduce the hand distance from the body by
 - changing the shape of the object or container so that it can be held closer to the body; and
 - providing grips or handles for enabling the load to be held closer to the body.
- Convert load lifting, carrying, and lowering movements to a push or pull by providing
 - conveyors
 - ball caster tables
 - hand trucks
 - four-wheel carts

Design Principles for Pushing and Pulling Tasks

Design principles for pushing and pulling tasks include the following:

- Eliminate the need to push or pull by using mechanical aids, when applicable such as
 - conveyors (powered and non-powered)
 - powered trucks
 - lift tables
 - slides or chutes

- Reduce the force required to push or pull by
 - reducing side and/or weight of load;
 - using four-wheeled trucks or dollies;
 - using non-powered conveyors;
 - requiring that wheels and casters on hand-trucks or dollies have: periodic lubrication of bearings, adequate maintenance, and proper sizing (provide larger diameter wheels and casters);
 - maintaining the floors to eliminate holes and bumps; and
 - requiring surface treatment of floors to reduce friction.
- Reduce the distance of the push or pull by
 - moving receiving, storage, production, or shipping areas closer to work production areas, and
 - improving the production process to eliminate unnecessary materials handling steps.
- Optimize the technique of the push or pull by
 - providing variable-height handles so that short and tall employees can maintain an elbow bend of 80 to 100 degrees,
 - replacing a pull with a push whenever possible, and
 - using ramps with a slope of less than 10 percent.

Design Principles for Carrying Tasks

Design principles for carrying tasks include the following:

- Eliminate the need to carry by rearranging the workplace to eliminate unnecessary materials movement and using the following mechanical handling aids, when applicable such as
 - conveyors (all kinds)
 - lift trucks and hand trucks
 - tables or slides between workstations
 - four-wheel carts or dollies
 - air or gravity press ejection systems
- Reduce the weight that is carried by
 - reducing the weight of the object,
 - reducing the weight of the container,
 - reducing the load in the container, and
 - reducing the quantity per container to suppliers.
- Reduce the bulk of the materials that are carried by
 - reducing the size or shape of the object or container,
 - providing handles or hand-grips that allow materials to be held close to the body, and
 - assigning the job to two or more persons.
- Reduce the carrying distance by
 - moving receiving, storage, or shipping areas closer to production areas; and
 - using powered and non-powered conveyors.
- Convert carry to push or pull by
 - using non-powered conveyers, and
 - using hand trucks and push carts.

c. Explain application of “single risk factors” for ergonomic hazards.

The following is taken from American Bankers, Appendix A, Ergonomic Risk Factor Descriptions and Examples to be Included in Required Awareness Training [section C(1)(a)].

Ergonomic risk factors are characteristics of a job that contribute to the creation of ergonomic hazards that may negatively impact job performance, including quality and productivity, as well as worker health. Risk factors are present at varying levels for different jobs and tasks. Generally, the greater the exposure is to a single risk factor or combination of risk factors, the greater the probability of an MSD. The mere presence of a risk factor does not necessarily mean that an employee performing a job is at undue risk of injury.

For job assessment of ergonomic risk factors consider the following:

- Awkward postures and motions—posture is the position your body is in that affects muscle groups and body parts involved in physical activity. Examples: extended reaching, twisting, bending, kneeling, squatting, or working overhead.
 - Forceful exertions—the amount of physical effort required to perform a task such as heavy lifting, or to maintain control of equipment or tools. The amount of force required to complete the task depends on the type of grip; the size, shape, and weight of an object; posture; and the type of activity. Examples: tasks involving gripping, lifting, carrying, lowering, pushing, pulling, holding, assembling, connecting, using a hand tool, and maintaining control of powered tools.
 - Repetition—a motion or activity that is repeated over and over again during a specific time period.
 - Sustained exertions—a body position that is maintained for an extended period of time.
 - Vibration—the oscillatory motion of an object. Vibration can be described in terms of its frequency, acceleration, and direction of motion. Examples: operating tools such as sanders, grinders, chippers, routers, drills, chain saws and other saws; jackhammers; or sitting/standing on vibrating surfaces such as driving a truck.
 - Contact stress—resting or pressing body parts against a hard surface or sharp edge can result in compression of nerves, muscles, tendons, blood vessels, and other tissues. Examples: pounding with the palm of hand; tools digging into the palm of hand; tools digging into the sides of fingers; or resting the knee, elbow, forearm, or wrist on a hard surface or sharp edge.
 - Cold temperature—exposure to low temperatures impacts the function of specific body parts, primarily hands and fingers. Examples: handling of frozen or refrigerated materials, cold environments, immersion of body parts in cold substances, or cold air exhaust.
- The risk factors may be evaluated by the following exposure properties:
- Duration—the amount of time a person is exposed to one or more risk factors.
 - Recovery—the periods of reduced exposure to risk factors. These may be rest breaks, pauses in work activity, or motions and exertions that provide specific body parts the opportunity to recuperate.

- Magnitude—the amount of each risk factor involved. Examples: the amount of force applied; the angle/position of the back, or the repetition rate.

d. Discuss methodology for analyzing lifting tasks.

The following is taken from TECNOMATIX, Task Analysis Toolkit.

Ergonomic methodologies for analyzing lifting tasks are now being done by use of software analysis tools. The following are some examples of software capabilities:

Low Back Spinal Force Analysis

The low back spinal force analysis tool helps evaluate the spinal forces acting on a virtual human's lower back under any posture and loading condition. Based on a complex biomechanical low back model incorporating the latest anatomical and physiological data, the tool helps

- determine whether newly defined or existing tasks conform to NIOSH guidelines or expose workers to an increased risk of low back injuries; and
- evaluate jobs in real-time, flagging the exact moments when the compression forces on a worker's low back exceed NIOSH recommended force limits.

Static Strength Prediction

The static strength prediction tool helps evaluate the percentage of a worker population that has the strength to perform a task based on posture, exertion requirements and anthropometry. Based on strength studies performed over 25 years at the University of Michigan Center for Ergonomics, the strength prediction tool

- aids in analyzing material handling tasks involving lifts, lowers, pushes, and pulls requiring complex hand forces, torso twists and bends;
- predicts the percentage of men and women who have the static strength to perform the prescribed job; and
- evaluates jobs in real-time, flagging postures where task requirements exceed NIOSH or user-specified strength capability limits.

NIOSH Lifting Analysis

The NIOSH lifting analysis tool helps evaluate symmetrical and asymmetrical lifting tasks, including lifts with less than optimal couplings between the object and the worker's hands. Based on NIOSH lifting equations developed by a committee of experts, the tool gives

- the expected weight or load, under given postural conditions, that most healthy workers could safely lift over a substantial period of time; and
- a relative estimate of the level of physical stress associated with a manual lifting task or a job involving multiple lifting tasks.

Predetermined Time Analysis

The predetermined time analysis tool helps predict the time required to perform a job by subdividing a task into a set of motions which have been assigned times based on the methods-time measurement system. This tool supports the

- design of manual tasks for optimal cycle times;
- evaluation of alternate work methods in planning manual tasks and equipment needs for new facilities; and

- identification of the tasks in a job and the variables of the tasks that represent the best opportunities for reducing the overall time required to perform a job.

Rapid Upper Limb Assessment

The rapid upper limb assessment (RULA) tool helps evaluate the exposure of workers to the risk of upper limb disorders. For a given manual task, RULA

- assesses the risk of upper limb disorders based on posture, muscle use, the weight of loads, task duration, and frequency; and
- assigns the evaluated task a score that indicates the degree of intervention required to reduce the risk of an upper limb injury.

Metabolic Energy Expenditure

The metabolic energy expenditure tool helps predict the metabolic energy expenditure requirements of a job based on worker characteristics and a description of the simple tasks that comprise the job. Based on the research this tool can help

- determine whether newly defined or existing jobs conform to NIOSH or user-specific guidelines for metabolic energy expenditure or expose workers to an increased risk of fatigue and injury; and
- identify the tasks in a job and the variables of the tasks that represent the best opportunities for reducing a job's overall energy expenditure requirements.

Manual Handling Limits

The manual handling limits tool helps evaluate and design manual handling tasks involving lifting, lowering, pushing, pulling, and carrying for reduced risk of low back pain. Based on 20 years of research conducted at the Liberty Mutual Research Center, the tool helps

- determine the maximum acceptable weight that men and women can handle when performing various lift, lower, push, pull, and carry tasks; and
- run "what-if" scenarios, altering the task variables to arrive at a job design that meets manual handling weight requirements; variables include object width, vertical distance, task frequency, and duration.

Fatigue/Recovery Time Analysis

The fatigue and recovery time analysis tool helps assess whether enough recovery time is available for a given job to avoid worker fatigue. Based on strength and fatigue studies undertaken by Rohmert, the tool computes the recovery time required for a job and compares it to available rest time. If there is not enough rest time in a job cycle to accommodate recovery time, workers are assumed to be at risk of fatigue. With the fatigue and recovery analysis tool, and in the

- design of manual tasks for minimal risk of work fatigue;
- analysis of worker fatigue in static postures or continuously during a real-time simulation; and
- identification of the tasks in a job that require the most recovery time and the muscle groups that are under the most strain.

Working Posture Analysis

The Ovako working posture analysis system tool provides a simple method for quickly checking the comfort of working postures and determining the urgency of taking corrective measures. The tool

- evaluates the relative discomfort of a working posture based on positioning of the back, arms, and legs, as well as load requirements; and
- assigns the evaluated posture a score that indicates the urgency of taking corrective measures to reduce the posture's potential to expose workers to injury.

e. Discuss significance of repetitive motions and tasks.

The following is taken from Iowa State University, Department of Environmental Health and Safety, Health and Safety, Repetition.

Repetition refers to performing a task or series of motions over and over again with little variation. When motions are repeated frequently (every few seconds) for prolonged periods (several hours, a work shift), fatigue and strain of the muscle and tendons can occur because there may be inadequate time for recovery. Repetition often involves the use of only a few muscles and body parts, which can become extremely fatigued while the rest of the body is little used.

Motions that are repeated again and again with little variation may cause fatigue and overuse of the muscles, tendons, and joints that are involved in the exertion. Overuse leads to muscle strain, inflammation of joints and tendons, and increased pressure on nerves. As exposure continues or intensifies (pace increases) tears in muscle fibers occur. The more frequently repetitive motions are performed (fast pace), the longer they are performed (long sessions without a break or more than 8 hours a day), and/or the more risk factors that are involved, the greater the risk of injury due to overuse and lack of adequate recovery time.

Exposure to repetition alone can cause MSDs. This is especially true where the same motions or tasks are performed for an extended period and/or where the task cycle is short (the task cycle lasts only a few seconds). The risk of injury is significantly increased when other risk factors are also present.

As task cycles in repetitive motion jobs get shorter (and the number of repetitions per minute increases) employees are at greater risk of injury. Where task cycles are short, the same muscles are in constant use and the muscles get no rest from the force required to perform the task cycle. In addition, where task cycles are short, there is little variation in the physical demands of the tasks, which would allow some muscles to rest while others are in use. Thus, muscle fatigue continues to accumulate and may lead to muscle-tendon strain.

f. Discuss importance of worker interfaces with operational equipment.

The following is taken from the Naval Safety Center, *Acquisition Safety Human Factors Engineering and Ergonomics*.

Planning, development, and production of new equipment and systems and the facilities needed for their support must take into account how the operator and maintainer fit into the design. Omitting the human factor and ergonomics (fitting the workplace to the worker) from designs has compromised the safe and efficient production, operation, and maintenance of equipment and facilities, both in the military and civilian sectors, leading to injuries and damage to equipment as well as costly retrofits.

Impacts of design influence material handling, assembly, and repair and interpretation of/interaction with displays and controls. Designs that disregard the basics of human physical characteristics and cognitive abilities can be associated with inefficient and costly operation and maintenance and with the injury or even fatality of the user. Aside from incurred costs for treatment and rehabilitation, injuries mean lost or restricted work time and productivity on the job as well as administrative costs associated with accident investigation and case management. Injuries can also reduce morale and job satisfaction, which can result in employment turnover and absenteeism.

Finally, accidents result in time and material costs when equipment has to be repaired or replaced and operations are delayed or cancelled. Poor designs, therefore, can and have jeopardized mission effectiveness, program performance, schedule, and costs. Designs that consider the human elements in all phases maximize productivity and operational effectiveness while protecting operators and maintainers from accidents and injuries.

Incorporation of ergonomics into system requirements, design development, and maintenance is not only required by policy, it is an effective risk management tool that supports performance, maintainability, and controls life-cycle cost and the risk of injury and errors.

Tasks, workstations, equipment, and tools that are matched to the task and user help to reduce the risk of developing MSDs by making it easier for the workers to avoid workplace risk factors. By incorporating human factors engineering (HFE)/ergonomics at the earliest phases of planning and design in the acquisition process, the frequency and severity of MSDs in the workplaces can be reduced or eliminated.

g. Discuss significance and definition of workplace tasks related to ergonomic consequences.

The following is taken from the U.S. Department of Labor, Occupational Safety and Health Administration, Ergonomics—Contributing Conditions.

Work-related and non-work related conditions can either individually, or by interacting with each other, give rise to MSDs. There are several approaches that may be used to determine whether conditions in the workplace might be contributing to employees developing MSDs. These approaches can be used individually or in combination.

Review and analyze injury and illness records to determine whether there is a pattern of ergonomic-related injuries in certain jobs or work tasks. Analyze the jobs or work tasks themselves to identify potential ergonomic problems before employee injuries occur.

Determine if jobs present ergonomic risks that may contribute to MSDs.

- Analysis tools may help in analyzing jobs. While there is no one size fits all approach, there are numerous non-OSHA, voluntary analysis tools that may be used to learn more about potential ergonomic risks associated with jobs.
- See employee input about the existence of ergonomic problems related to particular jobs or work tasks. This may be accomplished, among other ways
 - by speaking with employees
 - by conducting symptom surveys
 - through use of employee questionnaires

- Be aware of common contributing conditions within your industry or job classifications. If other companies in the same industry have ergonomic-related problems, then it is possible these potential problems are also your concern. Obtain information from others in your industry
 - to see what problems others have experienced in their operations
 - to gain a better understanding of potential problems that may exist in your workplace

h. Discuss methods to conduct workplace evaluations and communicate results to workers and management.

The following is taken from Occupational Health Services at the Workplace, by Dr. V. Forastieri.

The scope of surveillance of the working environment as defined by the International Labour Organization (ILO), Occupational Health Services Recommendation No. 171 is as follows:

- Identification and evaluation of the environmental factors that may affect the workers' health
- Assessment of conditions of occupational hygiene and factors in the organization of work which may give rise to risks for the health of workers
- Assessment of collective and personal protective equipment
- Assessment where appropriate of exposure of workers to hazardous agents by valid and generally accepted monitoring methods
- Assessment of control systems designed to eliminate or reduce exposure

The evaluation of health hazards in the workplace should be accomplished by considering the complete picture of exposures in comparison with established occupational exposure standards. Such standards are expressed in comparison with established occupational exposure standards. Such standards are expressed in terms of permissible levels and exposure limits and are set up through numerous scientific studies correlating exposure with produced health effects. Some of them have become state standards and are legally enforceable according to national law and practice. There are PELs for about 600 chemical substances commonly found in the workplace.

As information about potential workplace health hazards is obtained, it should be communicated to those responsible for implementing prevention and control measures as well as to the workers exposed to these hazards. The information should be as precise and quantitative as possible and it should describe the preventive measures being taken explaining what the worker should do to ensure their effectiveness.

The ILO Occupational Health Services Recommendation No. 171 provides that in accordance with national law and practice, data resulting from surveillance of the working environment should be recorded in an appropriate manner and be available to the employer, the workers, and their representatives or the safety and health committee where it exists.

i. Discuss human factors engineering as a method to identify hazards and develop controls.

The following is taken from DOE GPG-FM-027

The HFE effort will provide the best results when integrated with the development of a system. Figure 9 shows the life-cycle model for a system. Mapped onto the life-cycle model is a set of HFE efforts that should be implemented. These efforts are explained in DOE GPG-FM-027, *Human Factors Engineering*.

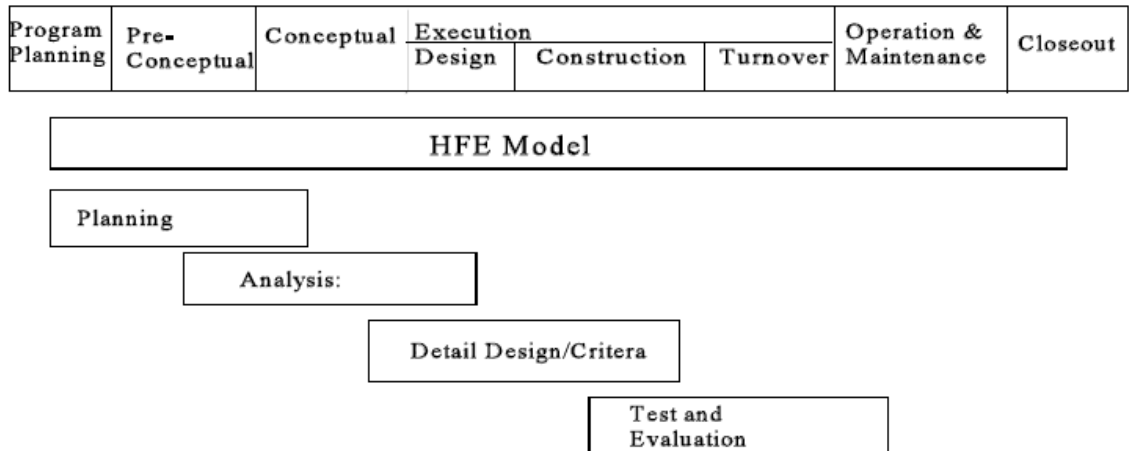

Source: DOE GPG-FM-027

Figure 9. Life-cycle model

Key to a HFE effort is the repeated application of a simple HFE model shown in figure 10.

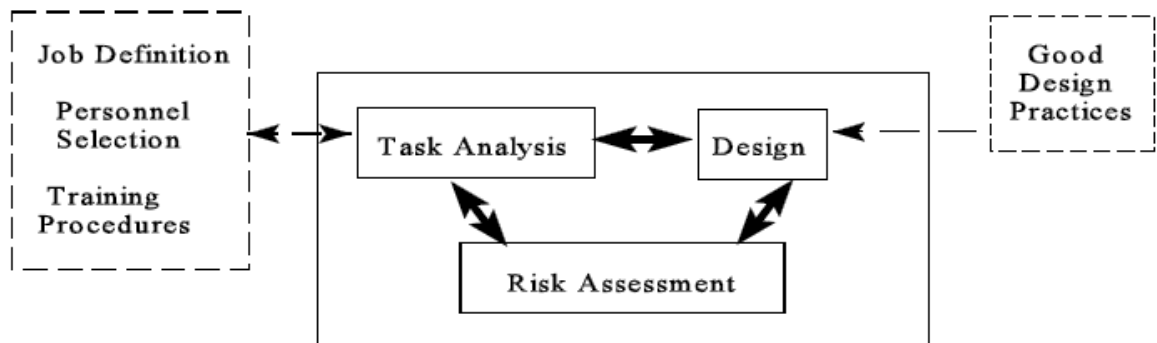

Source: DOE GPG-FM-027

Figure 10. Human factors engineering model

The main elements of this model are:

- Task Analysis: represents the development of the man-system interface needed. The man-system interface should result from the functional analysis and the assessment that man or automation can best accomplish the function.
- Design: results in the implementation that will satisfy the needed interface.
- Risk Assessment: establishes the detail and rigor needed in the design to satisfy the task.

The HFE effort may be graded to the complexity of the system and the life-cycle phases by the level of detail used in implementing the elements of the HFE model. The application of the elements of the HFE model is iterative throughout the system life cycle.

23. Occupational safety personnel must demonstrate a working level knowledge of safety precautions and hazards associated with workplace chemicals and physical agents.

a. Discuss hazards associated with the following chemical types:

- **Corrosives**
- **Flammable, combustible, and explosive materials**
- **Oxidizers**
- **Cryogenic liquids**
- **Toxic chemicals**
- **Asphyxiates**

Corrosives

The following is taken from the Canadian Centre for Occupational Health and Safety, *Corrosive Materials and Their Hazards*.

Corrosives can burn and destroy body tissues on contact. The stronger, or more concentrated the corrosive material is and the longer it touches the body, the worse injuries will be. Some corrosives are toxic and can cause other health problems.

Corrosive materials can severely irritate, or in some cases, burn the eyes. This could result in scars or permanent blindness. The stronger, or more concentrated the corrosive material is and the longer it touches the eyes, the worse the injury will be.

Corrosives touching the skin can severely irritate or even badly burn and blister the skin.

Severe corrosive burns over a large part of the body can cause death. Breathing in corrosive vapors or particles irritates and burns the inner lining of the nose, throat, windpipe, and lungs. In serious cases, this results in pulmonary edema, a buildup of fluid in the lungs that can be fatal.

Swallowing corrosives burns the sensitive lining of the mouth, throat, esophagus, and stomach. In nonfatal cases, severe scarring of the throat may occur and could result in losing the ability to swallow.

Some corrosives are also flammable or combustible and can easily catch fire and burn or explode. Some corrosives are incompatible with other chemicals. They may undergo dangerous chemical reactions and give off toxic or explosive products if they contact each other. The MSDSs and the labels on the containers should explain all of the hazards for the corrosive materials in the workplace.

Flammable, Combustible, and Explosive Materials

The following is taken from the Sacramento State Environmental Health and Safety, Chemical Hygiene Plan, Definitions.

According to the Department of Transportation (DOT) and NFPA, combustible liquids are those having a flash point at or above 100°F, or liquids that will burn. They do not ignite as easily as flammable liquids; however, combustible liquids can be ignited under certain circumstances, and must be handled with caution.

A flammable substance is one that will catch on fire and burn rapidly under ordinary conditions; for example, liquids with a flash point below 100°F and solids that ignite readily.

Explosives are chemicals that cause a sudden, almost instantaneous release of pressure, gas, and heat when subjected to sudden shock, pressure, or high temperature.

Oxidizers

The following is taken from Space Science, *Oxidizing Liquids & Solids—Hazards*.

Oxidizing materials may be toxic or corrosive. Depending on the material, route of exposure (inhalation, eye or skin contact, or swallowing) and dose, they could harm the body.

Corrosive oxidizers can also attack and destroy metal. The material safety data sheets (MSDSs) and the container labels should explain all of the hazards of the oxidizing materials that are used in the workplace.

An example is ammonium perchlorate. This material is a white or colorless, odorless crystal. It is used in explosives and fireworks; as an oxidizing agent in solid rocket and missile propellants; as an adhesive; as an engraving agent; laboratory (analytical) reagent; chemical intermediate for alkali and alkaline metal perchlorate; animal feed supplement; and in oxygen-generating devices for life-support systems in submarines, spacecraft, bomb shelters, and breathing apparatus.

Ammonium perchlorate can decompose at high temperatures forming toxic gases, such as chlorine, hydrogen chloride, and nitrogen oxides. Closed containers or tanks may rupture and explode if heated. It does not burn but is a powerful oxidizer and explosive when mixed with combustible materials. It is highly reactive and impact or high temperatures can cause violent decomposition or explosion. It can form shock-sensitive mixtures with finely powdered metals, metal oxides, strong reducing agents, sulfur and phosphorus. It may cause eye irritation.

Cryogenic Liquids

The following is taken from Wheeler, Michael D. and Christine A. Roeger, *Cryogenic Liquids and the Scientific Glassblower*.

Cryogenic liquids and their associated cold vapors and gases can produce effects on the skin similar to a thermal burn. Brief exposures that would not affect skin on the face or hands can damage delicate tissues such as the eyes. Prolonged exposure of the skin or contact with cold surfaces can cause frostbite. The skin appears waxy yellow. There is no initial pain, but there is intense pain when frozen tissues thaw. Unprotected skin can stick to metal that is cooled by cryogenic liquids. The skin can then tear when pulled away. Even non-metallic materials are dangerous to touch at low temperatures. Prolonged breathing of extremely cold air may damage the lungs.

When cryogenic liquids form a gas, the gas is very cold and usually heavier than air. This cold, heavy gas does not disperse very well and can accumulate near the floor. Even if the gas is non-toxic, it displaces air. Large volumes of nitrogen gas are evolved from small volumes of liquid nitrogen and this can easily replace normal air in poorly ventilated areas leading to the danger of asphyxiation. It should be noted that oxygen normally constitutes 21 percent of air. Atmospheres containing less than 10 percent oxygen can result in brain damage and death (the gasping reflex is triggered by excess carbon dioxide and not by shortage of oxygen), levels of 18 percent or less are dangerous, and entry into regions with levels less than 20 percent is not recommended. Each gas can cause specific health effects. For example, liquid carbon monoxide can release large quantities of carbon monoxide gas, which can cause death almost immediately.

Toxic Chemicals

The following is taken from Mostyn Law Firm's Beyond Expectations, *Injury from Toxic Substances...Answers to Your Questions*.

Toxic substances are chemicals prevalent in the workplace that are capable of causing harm. These include dusts, mixtures, paints, fuels, and solvents. Hazardous substances are used in many workplaces today. Working people are discovering that they need to know more about the health effects of chemicals they use or may be exposed to on the job. Textbooks, fact sheets, and MSDSs provide important information, but they are often written in technical language.

The toxicity of a substance is its ability to cause harmful effects. These effects can strike a single cell, a group of cells, an organ system, or the entire body. A toxic effect may be visible damage, or a decrease in performance or function measurable only by a test. The toxicity of a substance is absorbed by the body and the body's ability to detoxify the substance (change it into less toxic substances) and eliminate it from the body.

When a toxic substance causes damage at the point where it first contacts the body, that damage is called a local effect. The most common points at which the substances first contact the body are the skin, eyes, nose, throat, and lungs. Toxic substances can also enter the body and travel in the bloodstream to the internal organs. Effects that are produced this way are called systemic. The internal organs most commonly affected are the liver, kidneys, heart, nervous system (including the brain), and reproductive organs.

Toxic materials can take the form of solids, liquids, gases, vapors, dusts, fumes, fibers, and mists. How a substance gets into the body and what damage it causes depends on the form or the physical properties of the substance. Most solids are generally not hazardous since they are not likely to be absorbed into the body, unless present as small particles such as dust.

Many hazardous substances are in liquid form at normal temperatures. Some liquids can damage the skin. Some pass through the skin and enter the body and may or may not cause skin damage. The presence of a gas may be difficult to detect if it has no color or odor, and does not cause immediate irritation. Such gases, like carbon monoxide, may still be very hazardous. Vapors can be inhaled into the lungs, and in some cases may irritate the eyes, skin, or respiratory tract. Some are flammable, explosive, and/or toxic. Dusts may be hazardous because they can be inhaled into the respiratory tract. Larger

particles of dust are usually trapped in the nose and windpipe (trachea) where they can be expelled, but smaller particles (respirable dust) can reach and may damage the lungs.

Many metal fumes can cause an illness called metal fume fever, consisting of fever, chills, and aches like the flu. Smaller fibers such as asbestos, can lodge in the lungs and cause serious harm. Larger fibers are trapped in the respiratory tract; and are expelled without reaching the lung. The spraying of pesticides and the machining of metals using metal working fluids are two situations where mists are commonly produced. Often the damage a toxic substance causes does not surface in chronic form until years after exposure.

Asphyxiates

The following is taken from the Environment, Health & Safety Division of Berkley Lab, *Chemical Toxicology Overview*.

Chemical asphyxiants reduce the body's ability to absorb, transport, or utilize inhaled oxygen. They are often active at very low concentrations. Examples include: carbon monoxide, cyanides, and hydrogen sulfide.

b. Discuss the terminology associated with toxic chemical effects.

The following definitions are taken from the Department of Health and Human Services, Agency for Toxic Substances & Disease Registry (ATSDR), *Appendix B: ATSDR Glossary of Terms*.

Absorption: The process of taking in. For a person or an animal, absorption is the process of a substance getting into the body through the eyes, skin, stomach, intestines, or lungs.

Acute exposure: Contact with a substance that occurs once or for only a short time (up to 14 days).

Additive effect: A biologic response to exposure to multiple substances that equals the sum of responses of all the individual substances added together.

Adverse health effect: A change in body functions or cell structure that might lead to disease or health problems.

Anaerobic: Requiring the absence of oxygen.

Antagonistic effect: A biologic response to exposure to multiple substances that is less than would be expected if the known effects of the individual substances were added together.

Background level: An average or expected amount of a substance or radioactive material in a specific environment, or typical amounts of substances that occur naturally in an environment.

Biodegradation: Decomposition or breakdown of a substance through the action of microorganisms (such as bacteria or fungi) or other natural physical processes (such as sunlight).

Biologic monitoring: Measuring hazardous substances in biologic materials (such as blood, hair, urine, or breath) to determine whether exposure has occurred. A blood test, for lead is an example of biologic monitoring.

Biota: Plants and animals in an environment. Some of these plants and animals might be sources of food, clothing, or medicines for people.

Body burden: The total amount of a substance in the body. Some substances build up in the body because they are stored in fat or bone or because they leave the body very slowly.

Cancer: Any one of a group of diseases that occur when cells in the body become abnormal and grow or multiply out of control.

Cancer risk: A theoretical risk for getting cancer if exposed to a substance every day for 70 years (a lifetime exposure). The true risk might be lower.

Central nervous system: The part of the nervous system that consists of the brain and the spinal cord.

Chronic exposure: Contact with a substance that occurs over a long time (more than one year).

Cluster investigation: A review of an unusual number, real or perceived, of health events (for example, reports of cancer) grouped together in time and location. Cluster investigations are designed to confirm case reports; determine whether they represent an unusual disease occurrence; and, if possible, explore possible causes and contributing environmental factors.

Comprehensive Environmental Response, Compensation, and Liability Act of 1980 (CERCLA): Also known as Superfund is the Federal law that concerns the removal or cleanup of hazardous substances in the environment and at hazardous waste sites. ATSDR, which was created by CERCLA, is responsible for assessing health issues and supporting public health activities related to hazardous waste sites or other environmental releases of hazardous substances. This law was later amended by the Superfund Amendments and Reauthorization Act.

Concentration: The amount of a substance present in a certain amount of soil, water, air, food, blood, hair, urine, breath, or any other medium.

Contaminant: A substance that is either present in an environment where it does not belong or is present at levels that might cause harmful (adverse) health effects.

Delayed health effect: A disease or an injury that happens as a result of exposures that might have occurred in the past.

Dermal contact: Contact with (touching) the skin.

Detection limit: The lowest concentration of a chemical that can reliably be distinguished from a zero concentration.

Disease registry: A system of ongoing registration of all cases of a particular disease or health condition in a defined population.

Dose (for chemicals that are not radioactive): The amount of a substance to which a person is exposed over some time period. Dose is a measurement of exposure. Dose is often expressed as milligram (amount) per kilogram (a measure of body weight) per day (a measure of time) when people eat or drink contaminated food or water. In general, the greater the dose, the greater the likelihood of an effect. An “exposure dose” is how much of a substance is encountered in the environment. An “absorbed dose” is the amount of a substance that actually got into the body through the eyes, skin, stomach, intestines, or lungs.

EPA: United States Environmental Protection Agency.

Epidemiology: The study of the distribution and determinants of disease or health status in a population; the study of the occurrence and causes of health effects in humans.

Exposure: Contact with a substance by swallowing, breathing, or touching the skin or eyes. Exposure may be short-term (acute exposure), of intermediate duration, or long-term (chronic exposure).

Exposure assessment: The process of finding out how people come into contact with a hazardous substance, how often and for how long they are in contact with the substance, and how much of the substance they are in contact with.

Exposure-dose reconstruction: A method of estimating the amount of people’s past exposure to hazardous substances. Computer and approximation methods are used when past information is limited, not available, or missing.

Exposure pathway: The route a substance takes from its source (where it began) to its end point (where it ends), and how people can come into contact with (or get exposed to) it. An exposure pathway has five parts: a source of contamination (such as an abandoned business); an environmental medium and transport mechanism (such as movement through groundwater); a point of exposure (such as a private well); a route of exposure (eating, drinking, breathing, or touching), and a receptor population (people potentially or actually exposed). When all five parts are present, the exposure pathway is termed a completed exposure pathway.

Feasibility study: A study by the EPA to determine the best way to clean up environmental contamination. A number of factors are considered, including health risk, costs, and what methods will work well.

Half-life: The time it takes for half the original amount of a substance to disappear. In the environment, the half-life is the time it takes for half the original amount of a substance to disappear when it is changed to another chemical by bacteria, fungi, sunlight, or other chemical processes. In the human body, the half-life is the time it takes for half the original amount of the substance to disappear, either by being changed to another substance or by leaving the body. In the case of radioactive material, the half life is the amount of time necessary for one half the initial numbers of radioactive atoms to change

or transform into another atom (that is normally not radioactive). After two half lives, 25 percent of the original numbers of radioactive atoms remain.

Hazardous Substance Release and Health Effects Database: The scientific and administrative database system developed by ATSDR to manage data collection, retrieval, and analysis of site-specific information on hazardous substances, community health concerns, and public health activities.

Health statistics review: The analysis of existing health information (e.g., from death certificates, birth defects registries, and cancer registries) to determine if there is excess disease in a specific population, geographic area, and time period. A health statistics review is a descriptive epidemiologic study.

Indeterminate public health hazard: The category used in ATSDR's public health assessment documents when a professional judgment about the level of health hazard cannot be made because information critical to such a decision is lacking.

Ingestion: The act of swallowing something through eating, drinking, or mouthing objects. A hazardous substance can enter the body this way.

Inhalation: The act of breathing. A hazardous substance can enter the body this way.

Metabolism: The conversion or breakdown of a substance from one form to another by a living organism.

Minimal risk level (MRL): An ATSDR estimate of daily human exposure to a hazardous substance at or below which that substance is unlikely to pose a measurable risk of harmful, noncancerous effects. MRLs are calculated for a route of exposure over a specified time period. MRLs should not be used as predictors of harmful health effects.

Mortality: Death. Usually the cause is stated.

Mutagen: A substance that causes mutations (genetic damage).

Mutation: A change (damage) to the deoxyribonucleic acid (DNA), genes, or chromosomes of living organisms.

No apparent public health hazard: A category used in ATSDR's public health assessments for sites where human exposure to contaminated media might be occurring, might have occurred in the past, or might occur in the future, but where the exposure is not expected to cause any harmful health effects.

No-observed-adverse-effect level: The highest tested dose of a substance that has been reported to have no harmful (adverse) health effects on people or animals.

Physiologically based pharmacokinetic model: A computer model that describes what happens to a chemical in the body. This model describes how the chemical gets into the body, where it goes in the body, how it is changed by the body, and how it leaves the body.

Potentially responsible party (PRP): A company, government, or person legally responsible for cleaning up the pollution at a hazardous waste site under Superfund. There may be more than one PRP for a particular site.

Prevalence: The number of existing disease cases in a defined population during a specific time period.

Prevention: Actions that reduce exposure or other risks, keep people from getting sick, or keep disease from getting worse.

Public health advisory: A statement made by ATSDR to EPA or a state regulatory agency that a release of hazardous substances poses an immediate threat to human health. The advisory includes recommended measures to reduce exposure and reduce the threat to human health.

Public health hazard categories: Public health hazard categories are statements about whether people could be harmed by conditions present at the site in the past, present, or future. One or more hazard categories might be appropriate for each site. The five public health hazard categories are no public health hazard, no apparent public health hazard, indeterminate public health hazard, public health hazard, and urgent public health hazard.

Radionuclide: Any radioactive isotope (form) or any element.

Resource Conservation and Recovery Act (1976, 1984) (RCRA): This act regulates management and disposal of hazardous wastes currently generated, treated, stored, disposed of, or distributed.

Risk: The probability that something will cause injury or harm.

Route of exposure: The way people come into contact with a hazardous substance. Three routes of exposure are breathing (inhalation), eating or drinking (ingestion), or contact with the skin (dermal contact).

Solvent: A liquid capable of dissolving or dispersing another substance (for example, acetone or mineral spirits).

Source of contamination: The place where a hazardous substance comes from, such as a landfill, waste pond, incinerator, storage tank, or drum. A source of contamination is the first part of an exposure pathway.

Synergistic effect: A biologic response to multiple substances where one substance worsens the effect of another substance. The combined effect of the substances acting together is greater than the sum of the effects of the substances acting by themselves.

Teratogen: A substance that causes defects in development between conception and birth. A teratogen is a substance that causes a structural or functional birth defect.

Toxic agent: Chemical or physical (for example, radiation, heat, cold, microwaves) agents that, under certain circumstances of exposure, can cause harmful effects to living organisms.

Toxicological profile: An ATSDR document that examines, summarizes, and interprets information about a hazardous substance to determine harmful levels of exposure and associated health effects. A toxicological profile also identifies significant gaps in knowledge on the substance and describes areas where further research is needed.

Toxicology: The study of the harmful effects of substances on humans or animals.

Urgent public health hazard: A category used in ATSDR's public health assessments for sites where short-term exposure (less than one year) to hazardous substances or conditions could result in harmful health effects that require rapid intervention.

Volatile organic compounds (VOCs): Organic compounds that evaporate readily into the air. VOCs include substances such as benzene, toluene, methylene chloride, and methyl chloroform.

c. Describe general safety precautions that must be implemented or observed during the use, handling, storage, transportation, and disposal of each type of hazardous chemical listed above.

Corrosives

The following is taken from DOE-HDBK-1015/2-93.

Corrosives are available in numerous forms and varying concentrations. Some forms and concentrations are more hazardous than others, but the potential for serious accidents exists regardless of the substance in question.

Many of the safety precautions necessary for safe handling and storage are equally applicable to acids and alkalis.

Safety in handling hazardous chemicals depends to a great extent on effective employee education, proper safety practices, intelligent supervision, and the use of safe equipment.

Workers should be thoroughly informed of the hazards that may result from improper handling. Each employee should know what to do in an emergency and should be fully informed about proper first-aid measures. Hazards from spills and leaks should be minimized by an adequate supply of water for washing-down. Drainage of hard-surfaced or diked areas should be directed to minimize the exposure of personnel and equipment. Adequate ventilation should be provided in areas where chemical mist or dust is present.

Alkalis are much more injurious to the eyes than acids because strong acids tend to precipitate a protein barrier, which prevents further penetration into the tissue. The alkalis do not do this. They continue to soak into the tissue as long as they are allowed to remain in contact with the eye. The end result of a corrosive burn to the eye (alkali or acid) is usually a scar on the cornea and possible permanent damage.

Speed in removing corrosives is of primary importance. If the chemical enters the eyes, they should be copiously irrigated with water for at least 15 minutes, and a physician should be consulted immediately. In case of contact with skin or mucous membranes, the safety shower should be used immediately. Clothing can be removed under the shower. Contaminated skin areas should be washed with very large quantities of water for one to two hours, or until medical help arrives. The ready availability of water, particularly

safety showers and eye-washing baths, greatly minimizes the possibility of severe, extensive damage. Contaminated clothing and shoes should be thoroughly washed and decontaminated before re-use.

The use of PPE is not intended as a substitute for adequate control measures, but because corrosives can cause extensive damage to the body this equipment must be available as needed. During handling operations where spills or splashes are possible, whole body protection (eyes, head, body, hands, and feet) may be necessary. All PPE should be carefully cleaned and stored following use, and any equipment that cannot be decontaminated should be discarded.

For the protection of the eyes, chemical safety goggles should be worn. Face shields should be worn if complete face protection is necessary. Eyewash fountains and safety showers must be available at any location where eye and/or skin contact may occur. Protection against mist or dust can be provided by proper respiratory protective equipment. The wearing of protective clothing is also advisable to avoid skin contact. This may consist of rubber gloves, aprons, shoes or boots, and cotton coveralls which fit snugly. Safety shoes or boots made of rubber, chlorobutadiene, or other chemical-resistant materials with built-in steel toecaps are recommended for workers handling drums or in process areas where leakage may occur.

Containers should be stored in rooms with trapped floor drains. Curbs or a drained gutter, covered with an appropriate grill, should be constructed at door openings where floor drains are not provided.

Tanks should be entered for cleaning or repairing only after these have been drained, flushed thoroughly with water, ventilated, and sampled. Workers entering tanks should be monitored by someone on the outside of the tank. A supplied-air respirator or self-contained breathing apparatus, together with rescue harness and lifeline, should be on hand for rescue purposes.

Removal from exposure is the primary, and most important, step where exposure by inhalation is involved. The individual should be made as warm and comfortable as possible, and a physician should be called immediately.

Ingestion, the least common mode of contamination, requires immediate medical attention. Any attempt at first aid beyond drinking large quantities of water should be made only upon the advice of a physician.

If body burns are severe or extensive, or if the eyes are in any way involved, a physician should be consulted as soon as possible after first aid is rendered. No attempt should be made to neutralize the corrosive prior to treatment with water. Any treatment, in addition to the use of water, should be undertaken only with the advice of the physician.

When corrosives are shipped in small containers such as glass or polyethylene bottles, they should be well protected, whether individually packaged or several are packaged in a single case.

After careful inspection, the corrosives may be stored in these containers if the containers are maintained in an upright position and under cover. The containers should be kept off

the floor on materials that are corrosive resistant, or protected with corrosive-resistant coverings, to facilitate flushing and other cleanup procedures in the event of leakage or spills.

All drums should be stored on individual racks or securely blocked on skids, with the closure (plug) up to prevent leakage. Drums containing corrosives in liquid form should be vented when received, and at least weekly thereafter, to relieve accumulated internal pressure.

Cylinders should be stored in an upright position, preferably in individual racks and with the valve protective cap in place. In all cases, to avoid error, empty and full containers should be stored in different locations.

Under no circumstance should corrosives be transferred from the original labeled container to an unmarked container. All containers must be labeled clearly, concisely, and in simple, easily understood terms. Inspection of containers before handling will disclose conditions such as breakage, leakage, and improperly positioned closures which could readily cause a leak or spill.

In handling bottles, barrels, or drums containing corrosives, the following guidelines must be followed:

- Carefully inspect containers prior to handling.
- Use PPE.
- Use equipment specifically designed for the purpose of transporting and dispensing the chemical in question.
- Label all containers into which the chemical is transferred.

Properties of corrosives make several considerations mandatory in the selection of a storage site:

- The building, or area within the building selected, should be of fire-resistant construction.
- The floors should be composed of chemical-resistant brick or treated concrete, be washable, and be provided with adequate drainage.
- A well-lit and ventilated area in which there are adequate outlets for water should be provided.
- A relatively cool and dry environment should be maintained, preventing extremes of temperature and humidity.
- Electrical fixtures should be protected against corrosive mists, and wiring should be enclosed and covered with corrosive-resistant material.

The nature of the corrosive will determine the manner in which it is stored. Most acids should, to some extent, be isolated, some from all other chemicals, some from certain other acids and oxidizable materials such as oil and grease, and some from combustible materials.

Generally, adequate natural ventilation is sufficient in areas where corrosives are stored, that is, where the containers remain unopened. Where acid is used in work areas where dust or mists may arise, some form of mechanical exhaust system must be provided.

Transporting containers within the plant and dispensing at various points throughout the plant are two high-risk procedures that may cause an accident. Proper equipment can be readily obtained, which precludes the necessity of using makeshift or otherwise dangerous methods of transportation.

Hand trucks or power trucks used for transporting containers should have lifting parts, or clamps specially designed for that purpose. If bottles must be transported in the plant or laboratory, they should be enclosed in safety bottle carriers that prevent breakage if the bottle is struck or dropped. All containers (especially acid) must be opened slowly and cautiously because of the possible buildup of pressure within the container. Corrosives may be dispensed from drums by means of siphons, drum transfer pumps, or by gravity with the use of a special fitting, such as a self-closing faucet. Under no circumstances should bottles or drums be subjected to air pressure to expel the contents.

One final, and extremely important, consideration is the type of container or receptacle into which corrosives are to be dispensed. The use of an inappropriate or makeshift receptacle can negate the value of all precautionary measures.

These receptacles may be used for temporary storage or merely as a means of transporting from storage area to place of use. In any event, an appropriate receptacle meets several conditions:

- It is designed for the application.
- It is used for no other purpose than that for which it is intended.
- It is maintained in a safe, clean, and dry condition.

Flammable, Combustible, and Explosive Materials

The following is taken from DOE-HDBK-1015/2-93.

Avoid accidental mixture of flammable and combustible liquids. A small amount of a highly volatile substance may lower the flash point of a less volatile substance and form a more flammable mixture. In addition, the lower flash point liquid can act as a fuse to ignite the higher flash point material in the same manner as if it were a flammable mixture.

Fill and discharge lines and openings, as well as control valves associated with flammable and combustible systems, shall be identified by labels, color coding, or both, to prevent mixing different substances. All storage tanks shall be clearly labeled with the name of its contents, and products stored within shall not be intermixed. Transfer lines from different types and classes of flammable products should be kept separate, and preferably, different pumps should be provided for individual products.

For handling quantities of flammable liquids up to five gallons, a portable Factory Mutual Engineering Corp. or UL-approved container should be used. The container should be clearly identified by lettering or color code.

Smoking, the carrying of strike-anywhere matches, lighters, and other spark-producing devices should not be permitted in a building or area where flammable liquids are stored, handled, or used. The extent of the restricted area will depend on the type of products handled, the design of the building, local codes, and local conditions.

Suitable NO SMOKING signs should be posted conspicuously in those buildings and areas where smoking is prohibited.

Static electricity is generated by the contact and separation of dissimilar material. For example, static electricity is generated when a fluid flows through a pipe or from an orifice into a tank.

Examples of several methods of generating static electricity are shown in figure 11. The principal hazards created by static electricity are fire and explosion, which are caused by spark discharges.

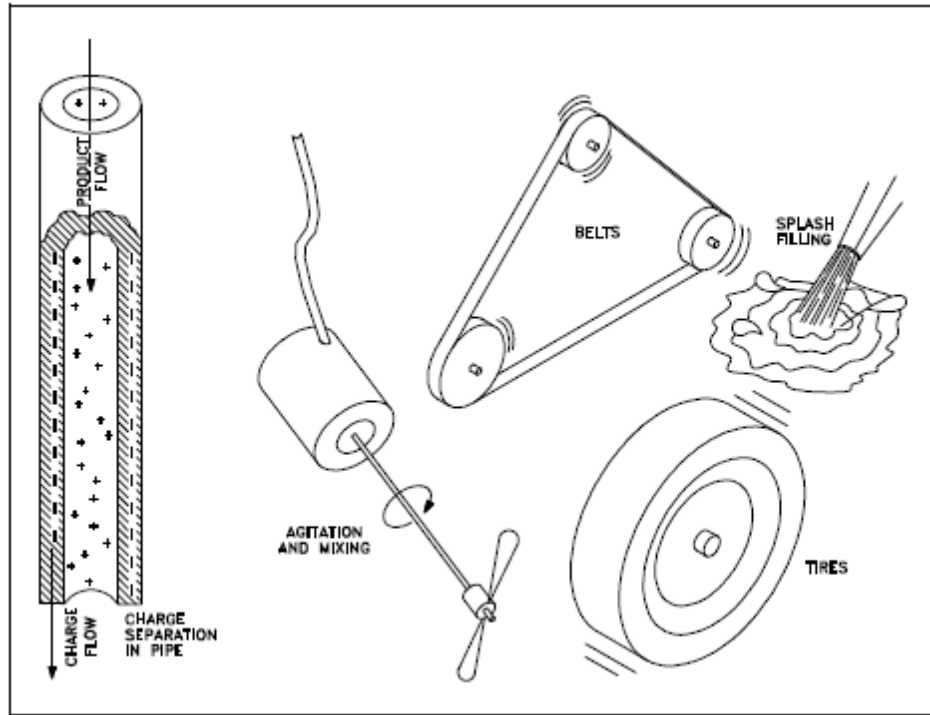

Source: DOE-HDBK-1015/2-93

Figure 11. Typical static-producing situations, including charge separation in pipe

A point of great danger from a static spark is where a flammable vapor is present in the air, such as the outlet of a flammable liquid fill pipe, at a delivery hose nozzle, near an open flammable liquid container, and around a tank truck fill opening. In the presence of a mechanism for generating a static charge, a spark between two bodies occurs when there is a poor electrical conductive path between them. Hence, grounding or bonding of flammable liquid containers is necessary to prevent static electricity from causing a spark.

The terms bonding and grounding have sometimes been used interchangeably because of a poor understanding of the terms. As illustrated in figure 12, bonding eliminates a difference in potential between objects. Grounding eliminates a difference in potential between an object and ground.

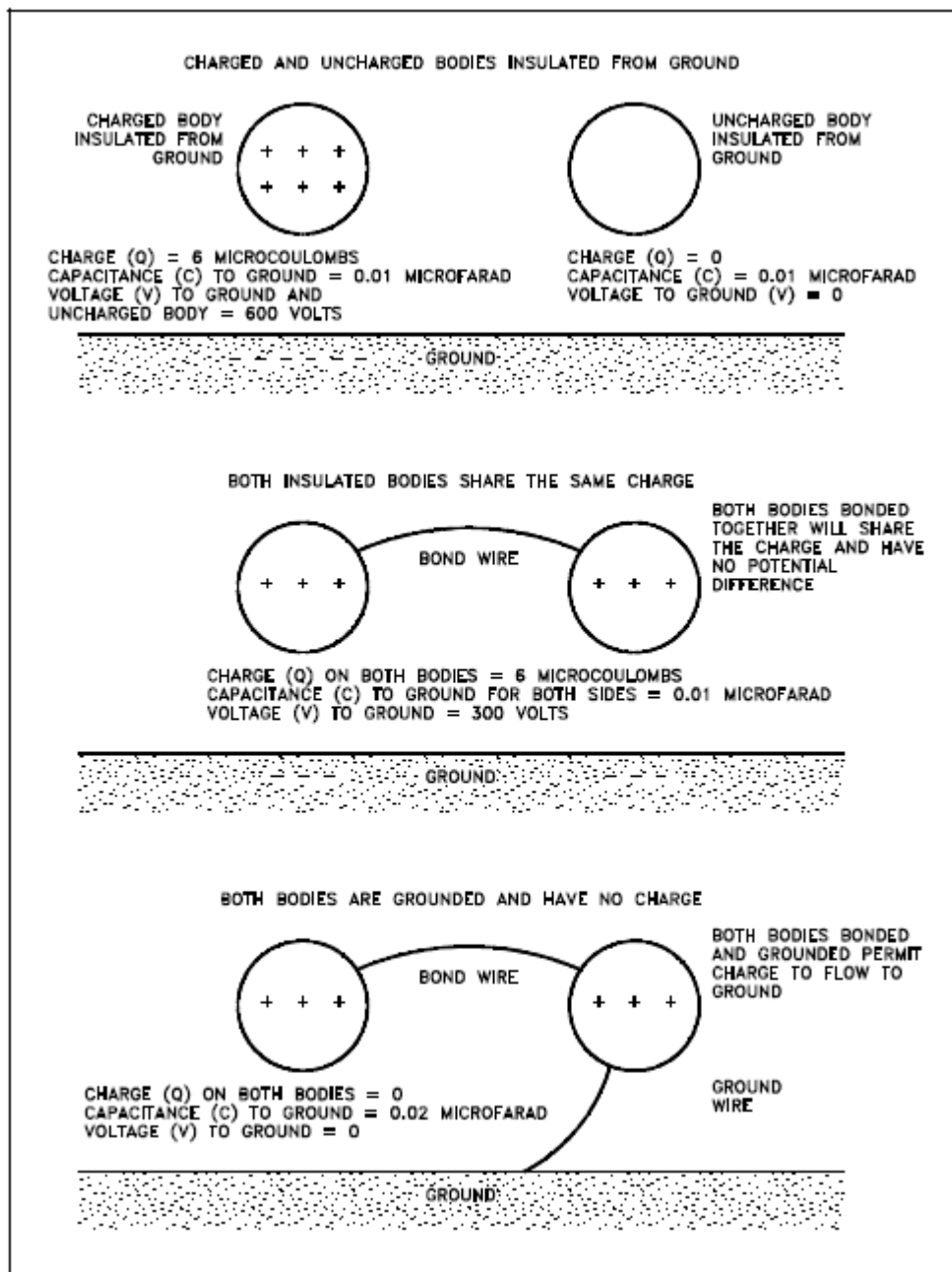

Source: DOE-HDBK-1015/2-93

Figure 12. Bonding and grounding

Bonding and grounding are effective only when the bonded objects are conductive. When two objects are bonded, the charges flow freely between the bodies, and there is no difference in their charge. Therefore, the likelihood of sparking between them is eliminated.

Although bonding eliminates a difference in potential between the objects that are bonded, it does not eliminate a difference in potential between these objects and the earth unless one of the objects possesses an adequate conductive path to earth. Therefore,

bonding will not eliminate the static charge, but will equalize the potential between the objects bonded so that a spark will not occur between them.

An adequate ground will discharge a charged conductive body continuously and is recommended as a safety measure whenever any doubt exists concerning a situation.

To avoid a spark from discharge of static electricity during flammable liquid filling operations, a wire bond should be provided between the storage container and the container being filled, unless a metallic path between the containers is otherwise present.

Above-ground tanks used for storage of flammable liquids do not have to be grounded unless they are on concrete or on nonconductive supports. Ground wires should be uninsulated so they may be easily inspected for mechanical damage and should never be painted. Figure 13 illustrates grounding above-ground storage tanks.

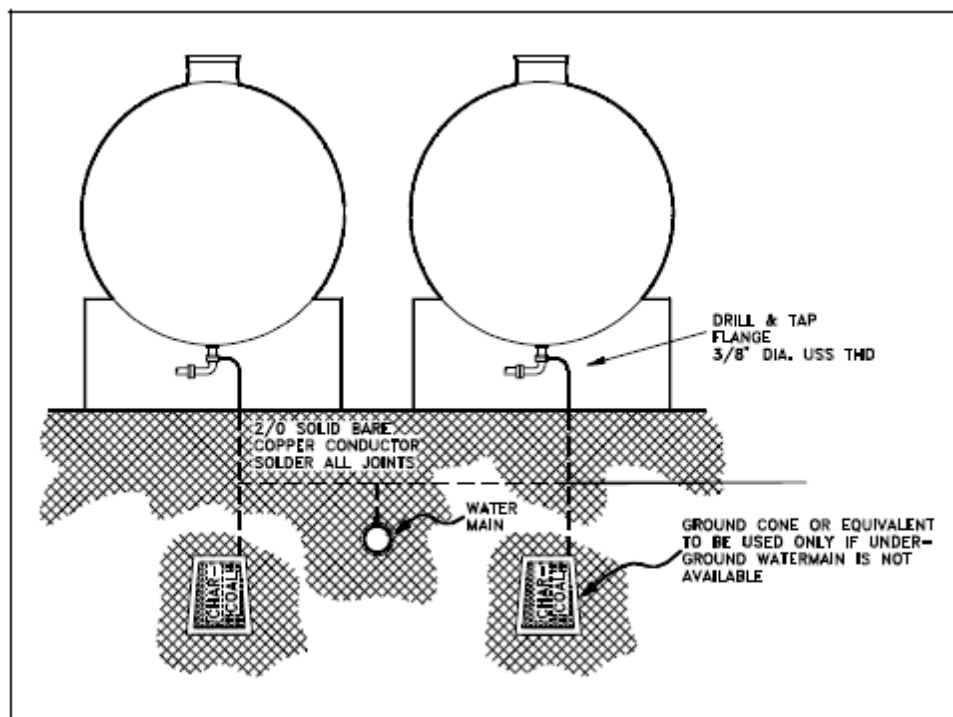

Source: DOE-HDBK-1015/2-93

Figure 13. Grounding above-ground storage tanks

Petroleum liquids are capable of building up electrical charges when they 1) flow through piping, 2) are agitated in a tank or a container, or 3) are subjected to vigorous mechanical movement such as spraying or splashing. Proper bonding or grounding of the transfer system usually dissipates this static charge to ground as it is generated. However, rapid flow rates in transfer lines can cause very high electrical potentials on the surface of liquids regardless of vessel grounding. Also, some petroleum liquids are poor conductors of electricity, particularly the pure, refined products, and even though the transfer system is properly grounded, a static charge may build up on the surface of the liquid in the receiving container. The charge accumulates because static electricity cannot flow through the liquid to the grounded metal container as fast as it is being generated. If this accumulated charge builds up high enough, a static spark with sufficient energy to ignite

a flammable air-vapor mixture can occur when the liquid level approaches a grounded probe or when a probe is lowered into a tank for sampling or gaging.

This high static charge is usually controlled by reducing the flow rates, avoiding violent splashing with side-flow fill lines, and using relaxation time, which allows time for the static charge to discharge.

When flammable liquids are transferred from one container to another, a means of bonding should be provided between the two conductive containers prior to pouring, as shown in figure 14.

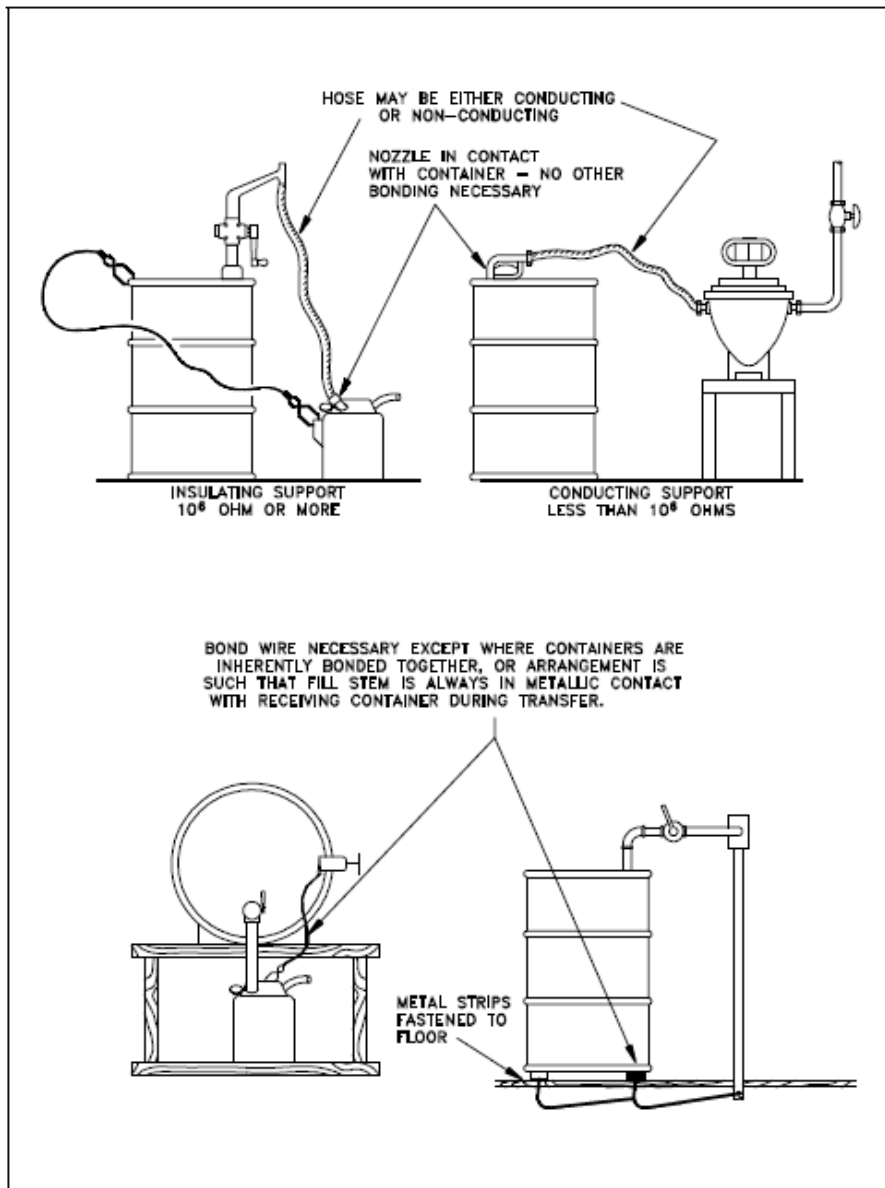

Source: DOE-HDBK-1015/2-93

Figure 14. Bonding during container filling

In areas where flammable liquids are stored or used, hose nozzles on steam lines used for cleaning should be bonded to the surface of the vessel or object being cleaned. Also,

there should be no insulated conductive objects on which the steam could impinge and induce a static charge accumulation.

Nonconductive materials, such as fabric, rubber, or plastic sheeting, passing through or over rolls will also create charges of static electricity. Static from these materials, as well as static from the belts, can be discharged with grounded metal combs or tinsel collectors. Radioactive substances and static neutralizers using electrical discharges are also employed for this purpose.

Bonding and grounding systems should be checked regularly for electrical continuity. Preferably before each fill, the exposed part of the bonding and ground system should be inspected for parts that have deteriorated because of corrosion or that have otherwise been damaged. Many companies specify that bonds and grounds be constructed of bare-braided flexible wire because it facilitates inspection and prevents broken wires from being concealed.

Electricity becomes a source of ignition where flammable vapors exist if the proper type of electrical equipment for these atmospheres either has not been installed or has not been maintained.

A summary of reports of experimental evidence and practical experience in the petroleum industry shows that no significant increase in fire safety is gained by the use of spark-resistant hand tools in the presence of gasoline and similar hydrocarbon vapors. However, some materials such as carbon disulfide, acetylene, and ethyl ether have very low ignition energy requirements.

For these and similar materials, the use of special tools designed to minimize the danger of sparks in hazardous locations can be recognized as a conservative safety measure.

Leather-faced, plastic, and wood tools are free from the friction-spark hazard, although metallic particles may possibly become embedded in them.

Flammable and combustible liquids and their vapors may create health hazards from both skin contact and inhalation of toxic vapors. Irritation results from the solvent action of many flammable liquids on the natural skin oils and tissue. A toxic hazard of varying degree exists in practically all cases, depending on the concentration of the vapor.

Most vapors from flammable and combustible liquids are heavier than air and will flow into pits, tank openings, confined areas, and low places in which they contaminate the normal air, and cause a toxic as well as explosive atmosphere. Oxygen deficiency occurs in closed containers, such as a tank which has been closed for a long time, and in which rusting has consumed the oxygen. All containers should be aired and tested for toxic and flammable atmosphere as well as the oxygen level before entry.

Class I and class II liquids should not be kept or stored in a building except in approved containers, as illustrated in figure 15, within either a storage cabinet or a storage room that does not have an opening that communicates with the public portion of the building. The spring-loaded cover is designed to open in order to relieve internal vapor pressure.

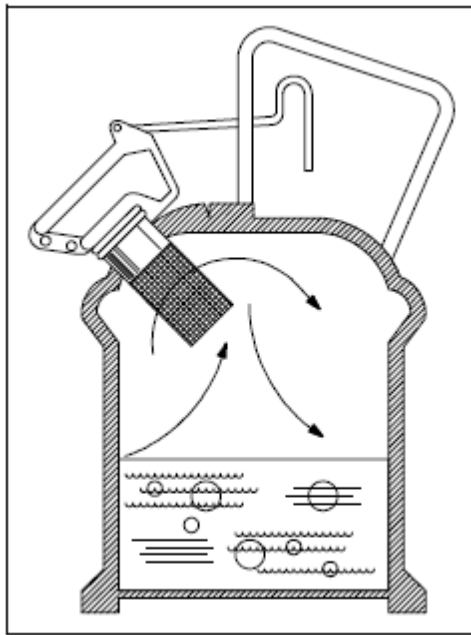

Source: DOE-HDBK-1015/2-93

Figure 15. Storage container with spring loaded cover

Quantities stored in such locations should be limited. They should not be stored so as to limit use of exits, stairways, or areas normally used for the safe egress of people. Neither should they be stored close to stoves or heated pipes, nor exposed to the rays of the sun or other sources of heat.

Losses by evaporation of liquid stored in safety cans at ordinary temperatures are negligible. Storage of flammable and combustible liquids in open containers should not be permitted. Approved containers for flammable liquids should be closed after each use and when empty. Warning labels should be removed from flammable liquid containers when empty (vapor free).

Bulk class I liquids should be stored in an underground (buried) tank or outside a building. No outlet from the tank should be inside a building unless it terminates in a special room, as illustrated in figure 16.

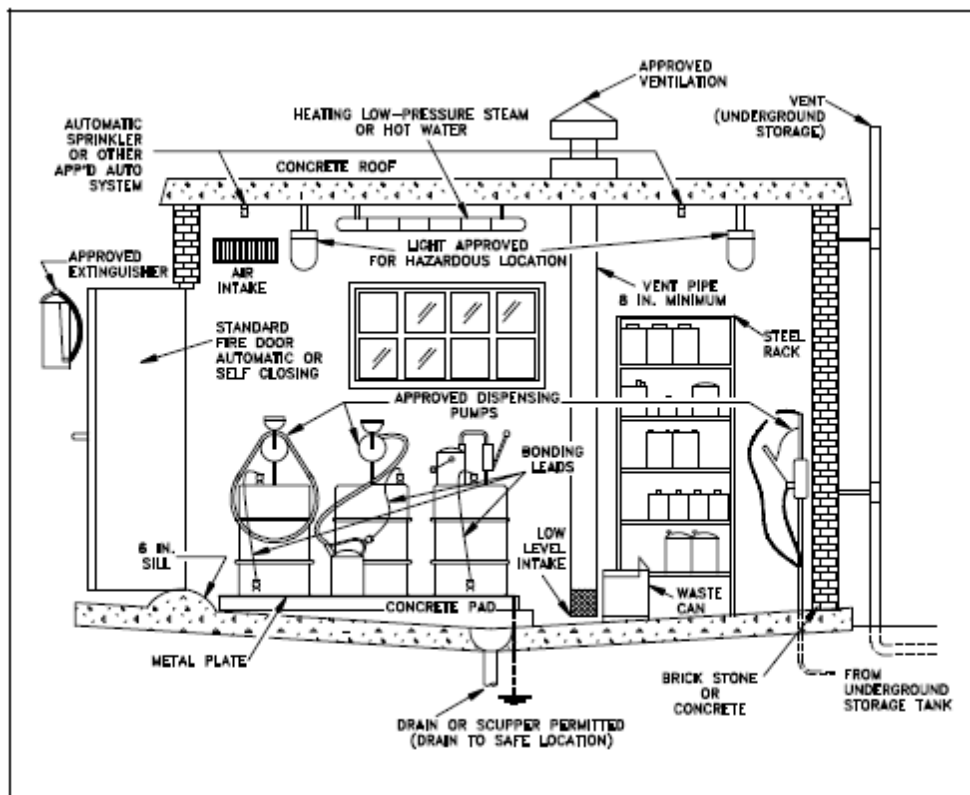

Source: DOE-HDBK1015/2-93

Figure 16. A flammable liquid mixing and storage room

Vehicles used on plant property to transport flammable and combustible liquids in sealed containers should be designed to minimize damage to the containers. When employees are filling tanks and other containers, they should be sure to allow sufficient vapor space (outage) above the liquid level in order to permit expansion of the liquid with changing temperatures. For example, gasoline expands at the rate of about one percent for each 14°F rise in temperature. Outage space for gasoline of two percent of the capacity of the tank or compartment is recommended, and permanent high-level markings should be installed.

Storage tanks should be provided with vents. Vent pipes of underground tanks storing class I flammable liquids should terminate outside buildings, higher than the fill pipe opening, and not less than 12 feet above the adjacent ground level. They should discharge vertically upward, and be located so that flammable vapors cannot enter building openings or be trapped under eaves or other obstructions. Vent pipes from underground tanks storing class II or class III liquids should terminate outside buildings and higher than the fill pipe opening. Vent outlets should be above normal snow level.

Additional information concerning installation, protection, and spacing of storage tanks located above ground, underground, or in areas subject to flooding is beyond the scope of this course. If this information is desired, it may be found in the NFPA standards.

Flammable or combustible liquids in sealed containers represent a potential hazard rather than an active hazard—the possibility of fire from without. By the same reasoning, inside storage rooms are undesirable. If they must be used, they should be isolated as much as

possible, and located at or above ground level. They should not be located over basements and should preferably be along an exterior wall.

Every inside storage room shall be provided with either a gravity or a continuous mechanical exhaust ventilation system. Mechanical ventilation must be used if class I liquids are contained or dispensed inside the room.

Storage cabinets have specific limits on the amount and class of flammable or combustible liquids that may be stored in them. They must be constructed and sealed so as to be fire resistant. Cabinets shall be labeled conspicuously—FLAMMABLE-KEEP FIRE AWAY.

The most advisable storage facility is a separate building set some distance from normally occupied plant areas. The construction can be similar to that specified for inside storage rooms. The types and classes of flammable and combustible liquids stored will determine the best design to be used.

Oxidizers

The following is taken from Layne, *Oxidizers*.

Each chemical may require different handling procedures. The following guidelines are just that—guidelines. The only way to be 100 percent safe when working with any chemical is to read and follow the information on the MSDS.

- Never store containers near oil, grease, fuel, oil-based paint or other petroleum products.
- Never store oxygen bottles next to acetylene bottles.
- Keep containers in well-ventilated, cool areas out of direct sunlight.
- Keep labels clean.
- Inspect containers often for leaks, damage, and spills.
- Keep containers closed when they aren't being used.
- Never use oily rags for cleanup or put rags used with oxidizers into containers holding oily rags.
- Most oxidizer fires should be put out with a class B fire extinguisher.
- If you or a co-worker breathes in an oxidizer, get to fresh air immediately and call a doctor.
- If it gets on skin or in eyes, rinse the area with water for a minimum of 20 minutes and get medical attention.
- If chemicals get on clothing, remove them immediately, decontaminate, wash, or dispose of them.

Cryogenic Liquids

The following is taken from DOE-HDBK-1015/2-93.

Most cryogenic liquids are colorless, odorless, and tasteless when vaporized to a gas. As liquids, most have no color. However, whenever the cold liquid and vapor are exposed to the atmosphere a warning appears. As the boil-off gases condense moisture in the air, a fog forms that extends over an area larger than the vaporizing gas. Many cryogenic liquids are inert gases, and may inert an enclosed space. Inert gases will not support life.

The liquid and its boil-off vapor can rapidly freeze human tissue and can cause many common materials such as carbon steel, plastic, and rubber to become brittle or fracture under stress. Liquids in containers and piping at temperatures at or below the boiling point of liquefied air (-318°F) can cause the surrounding air to condense to a liquid.

Extremely cold liquefied gases (helium, hydrogen, and neon) can even solidify air or other gases to which they are directly exposed. In some cases, plugs of ice or foreign material will develop in cryogenic container vents and openings and cause the vessel to rupture. If a plug forms, contact the supplier immediately. Do not attempt to remove the plug; move the vessel to a remote location.

All cryogenic liquids produce large volumes of gas when they vaporize. For example, 1 volume of saturated liquid nitrogen at 1 atmosphere vaporizes to 696.5 volumes of nitrogen gas at room temperature at 1 atmosphere.

When vaporized in a sealed container, cryogenic liquids produce enormous pressures. If 1 volume of liquid helium at 1 atmosphere is warmed to room temperature and vaporized in a totally enclosed container, it has the potential to generate a pressure of more than 14,500 psig.

Because of this high pressure, cryogenic containers are usually protected with two pressure-relief devices, a pressure-relief valve and a frangible disk.

Many safety precautions that must be taken with compressed gases also apply to liquefied gases. However, some additional precautions are necessary because of the special properties exhibited by fluids at cryogenic temperatures.

The properties of cryogenic liquids affect their safe handling and use. Always handle cryogenic liquids carefully. They can cause frostbite on skin and exposed eye tissue. When spilled, they tend to spread, covering a surface completely and cooling a large area. The vapors emitted by these liquids are also extremely cold and can damage tissues. The vapor boil-off may inert the immediate vicinity.

Stand clear of boiling or splashing liquid and its vapors. Boiling and splashing occur when a warm container is charged or when warm objects are inserted into a liquid. These operations should always be performed slowly to minimize boiling and splashing. If cold liquid or vapor comes in contact with the skin or eyes, first aid should be given immediately.

Never allow an unprotected part of the body to touch uninsulated pipes or vessels that contain cryogenic fluids. The extremely cold metal will cause the flesh to stick fast to the surface and tear when withdrawn. Touching even nonmetallic materials at low temperatures is dangerous.

Tongs, or a similar device, should be used to withdraw objects immersed in a cryogenic liquid. Materials that are soft and pliable at room temperature become hard and brittle at extremely low temperatures and will break easily.

Workers handling cryogenic liquids should use eye and hand protection to protect against splashing and cold-contact burns. Safety glasses are also recommended. If severe

spraying or splashing is likely, a face shield or chemical goggles should be worn. Protective gloves should always be worn when anything that comes in contact with cold liquids and their vapors is being handled. Gloves should be loose fitting so that they can be removed quickly if liquids are spilled into them. Trousers should remain outside of boots or work shoes.

Toxic Chemicals

Because the types of toxic compounds found in industry number in the thousands, and because specific hazards, controls, and corrective measures may vary with the substance.

Material safety data sheets are required for all potentially hazardous and toxic materials and should be consulted for specific descriptions and precautions concerning the substance in question.

There are some general precautions that should be universally employed regarding toxic compounds. Many of these precautions are consistent with those already mentioned concerning corrosives. Proper ventilation, appropriate hygienic practices, housekeeping, protective clothing, and training for safe handling and storage will diminish many of the hazards that exist.

The toxicity of a material is not synonymous with its health hazard. Toxicity is the capacity of a material to produce injury or harm to a living organism.

Hazard is the possibility that a material will cause injury when a specific quantity is used under specific conditions. Several key elements are considered when evaluating a health hazard.

- Toxicity of the materials used
- Physical properties of these materials
- Absorption probabilities of these materials by individuals
- Extent and intensity of exposure to these materials
- Control measures used

Toxicity is relative. It refers to a harmful effect on some biologic mechanism. The term toxicity is commonly used in comparing one chemical agent with another, but such comparison is meaningless if the biologic mechanism, and the conditions under which the harmful effects occur, are not specified.

Although the toxic effects of many chemical agents used in industry are well known, the toxic effects of many other commonly used chemical agents are not as well defined. The toxicity of a material is not a physical constant; therefore, only a general statement can be made concerning the harmful nature of a given chemical agent.

Many chemical agents are nonselective in their action on tissue or cells; they may exert a harmful effect on all living matter. Other chemical agents may act only on specific cells. Another agent may be harmful only to certain species; other species may have built-in protective devices.

The degree to which a substance will affect living cells can be measured only after recognizable changes have occurred following absorption. Some changes may be produced at levels too low to cause actual cell damage. Toxicity is dependent on the dose,

rate, method, and site of absorption, and many other factors, including general state of health, individual differences, tolerance, diet, and temperature.

In general, industrial poisonings usually result from inhalation, ingestion, and absorption. The inhalation and absorption of toxic agents by the lungs is dependent on the solubility in body fluids, the diffusion through the lungs, the volume of inhalation, the volume of blood in the lungs, and the concentration gradient of vapors between the inhaled air and the blood.

Ingestion of the toxic agent can occur to some extent; however, there would generally be considerable inhalation of the material where such conditions exist.

Absorption through the skin can occur upon exposure to some toxic agents. Some liquids and vapors are known to pass through the skin in concentrations high enough such that respiratory protection is not adequate. For example, hydrogen cyanide is known to pass through the unbroken skin. Consideration should be given to the type of work clothes being worn; if they become saturated with solvents, they will act as a reservoir to bathe the body continually with the harmful material.

Most volatile (easily vaporized) organic compounds are eliminated from the body in a matter of hours or, at most, days. Many of the poisonous elements, however, can be stored for long periods of time in various parts of the body. Chronic toxicity damage is unlikely to have an even distribution throughout the body. In toxicity studies with radioactive isotopes, the organ which suffers the most severe damage and appears to contribute most to the toxic effect on the body as a whole, is called the critical organ. The particular organ that shows the largest amount of damage is the one that is chosen for estimating the effect.

Industrial poisoning may be classified as either acute or chronic. The classification is based on the rate of intake of harmful materials, rate of onset of symptoms, and the duration of symptoms.

Acute poisoning is characterized by rapid absorption of the material and sudden, severe exposure. For example, inhaling high levels of carbon monoxide or swallowing a large quantity of cyanide compound will produce acute poisoning. Generally, acute poisoning results from a single dose which is rapidly absorbed and damages one or more of the vital physiological processes. The development of cancer long after recovery from acute radiation damage is called a delayed acute effect.

Chronic poisoning is characterized by absorption of a harmful material in small doses over a long period of time; each dose, if taken alone, would barely be effective. In chronic poisoning, the harmful materials remain in the tissues, continually injuring a body process. The symptoms in chronic poisoning are usually different from the symptoms seen in acute poisoning by the same toxic agent.

The Occupational Safety and Health Act of 1970 requires that the health and human services publish at least annually, a list of all known toxic substances by generic family, or other useful grouping, and the concentrations at which such toxicity is known to occur. Under the OSHA Act, the Secretary of Labor must issue regulations requiring employers

to monitor employee exposure to toxic materials and to keep records of any such exposure.

The purpose of the toxic substances list is to identify all known toxic substances in accordance with definitions that may be used by all sections of our society to describe toxicity.

It must be emphatically stated that the presence of a substance on the list does not automatically mean that it is to be avoided. A listing does mean, however, that the substance has the documented potential of being hazardous if misused, and, therefore, care must be exercised to prevent tragic consequences.

The absence of a substance from the list does not necessarily indicate that a substance is not toxic. Some hazardous substances may not qualify for the list because the dose that causes the toxic effect is not known.

Other chemicals associated with skin sensitization and carcinogenicity may be omitted from the list, because these effects have not been reproduced in experimental animals or because the human data is not definitive.

It is not the purpose of the list to quantify the hazard by way of the toxic concentration or dose that is presented with each of the substances listed. Hazard evaluation involves far more than the recognition of a toxic substance and knowledge of its relative toxic potency. It involves a measurement of the quantity that is available for absorption by the user, the amount of time that is available for absorption, the frequency with which the exposure occurs, the physical form of the substances, and the presence of other substances, additives, or contaminants.

The purpose of the MSDS is to ensure the individuals working with chemicals and in the vicinity of chemicals have specific information on these chemicals. This form identifies the chemical by its technical and common name and lists the physical/chemical characteristics and fire, explosion, and reactivity hazards. The second page specifies health hazards and recommends first-aid procedures. The safe handling and control measures are also supplied. The MSDS is a very helpful document, and personnel working around chemicals should make it a practice to review these sheets frequently for their own safety.

The Code of Federal Regulations recommends that the hazards of all chemicals produced and imported be evaluated and the information concerning the hazards be transmitted to the employers and employees. The MSDS, labels on containers, and employee training should be part of a comprehensive hazards communication program.

Asphyxiates

The following is taken from the Technical Safety Institute, HAZWOPER Refresher Training.

Oxygen deficiency can result from operations on worksites from the displacement of oxygen by another gas, such as methane, or the consumption of oxygen by a chemical reaction, such as rust inside a vessel. Confined spaces, open test pits or low-lying areas are particularly vulnerable to oxygen deficiency and should always be monitored prior to

entry. Qualified field personnel should always monitor oxygen levels and should use atmosphere-supplying respiratory equipment when oxygen concentrations drop below 19.5 percent by volume.

d. Describe relationships and hazards associated with chemicals in a confined space entry and how their presence could dictate the confined space designation. Describe a proper confined space program, including entry precautions and procedures.

The following is taken from the Naval Safety Center, Acquisition Safety—Confined Spaces.

Confined spaces are compartments or enclosures that have limited openings for entry and exit; are not intended for continuous human occupancy; and are only suitable for temporary work such as inspections, maintenance, or repairs. These spaces may be oxygen deficient, contain fire, explosion, or toxicity hazards, or hold liquid, sludge, or solids that create potential engulfment and/or drowning hazards.

Hazardous Atmospheres

The internal atmosphere of confined spaces may be oxygen deficient, flammable or explosive, toxic, or oxygen enriched, which may result in the risk of suffocation, fire, and explosion or impaired physical capability for persons entering these spaces. A hazardous atmosphere is defined by its potential to disable and/or injure those exposed. It may be characterized by how much it differs from the normal air we breathe. Normal air is defined as approximately 21 percent oxygen, 73 percent nitrogen, a trace of carbon dioxide, and a very small trace of other gases such as argon. If levels of these constituents change, whether up or down in concentration, then the atmosphere is considered hazardous.

Asphyxiating Atmospheres

Oxygen deficiency may be caused by oxidation reactions such as fire or rusting. It also can take place during combustion of flammable substances, as in welding, heating, cutting, and brazing. Other causes for oxygen deficiency include the dilution of air with an inert gas and absorption by grains, chemicals, or soils. Normal air contains 20.9 percent oxygen; once the level drops below 19.5 percent, the air becomes hazardous to breathe. As the level of oxygen is decreased in a space, the danger of asphyxiation for anyone entering that space increases. Oxygen deficiency provides minimal sensory warning. Symptoms may include ringing in the ears, dizziness, and often impaired cognitive functions. The victim may initially feel giddy and be otherwise impaired in their ability to sense the onset of problems.

Toxic Atmospheres

Toxic gases and vapors come from evaporation of fuel and solvents, or may be formed in the process of fermentation and during decomposition of both animal and vegetable material. Welding or brazing with metals such as mild steel, high strength and stainless steel produces toxic metal fumes and hazardous gaseous byproducts; recirculation of diesel exhaust emissions (used to suppress fuel tank atmospheres) will create a toxic atmosphere; and collection and holding tanks for sewage generate hydrogen sulfide, methane, and other hazardous byproducts in the tanks, piping, and valves.

Flammable and Explosive Atmospheres

This condition generally arises from vaporization of flammable liquids, byproducts of work such as spray painting and welding, chemical reactions, concentrations of combustible dusts, and desorption of chemicals from inner surfaces of the confined space. Welding or other hot work may liberate flammable vapors from combustible liquids previously stored in a compartment. Gas free procedures must evaluate not only the present material stored in an area, but must also consider previous cargoes and contents of adjacent spaces.

Other Common Confined Space Challenges

Communication Problems

If a worker in a confined space should suddenly feel distressed and is not able to summon help, an injury could become a fatality. Frequently, the body positions that are assumed in a confined space make it difficult for the standby person to detect an unconscious worker.

Visual monitoring of the worker is often not possible because of the design of the confined space or location of the entry hatch. Effective process management and supporting OSHA regulations require provision for communication between worker and monitor and the means for emergency rescue, which must be identified before confined space entry.

Entry and Exit Limitation

The time it takes to enter and exit confined spaces may increase the hazards of exposure to the confined space atmosphere.

Other Physical Hazards

While working in a confined space, workers can become fatigued or be exposed to extreme heat and/or cold, hazardous noise levels, vibration, or radiation. Drowning hazards include engulfment in sludge and other liquids. Additional physical hazards include inadvertent contact with electrical, rotating, or mechanical equipment, steam, or other sources of burning heat and moving parts.

Fall Prevention for Entering and Working in Confined Spaces

Confined spaces also present the risk of slips, trips, and falls, especially where corrosion has caused rust, which damages ladders, walking surfaces, and anchor points for PFASs. Many tanks have no proper fall protection equipment, anchors, or ladders inside. Tanks can be as deep as 60 feet requiring scaffolding to be set up to perform maintenance. Scaffolding can present another fall hazard.

Recommendations

The first goal is to eliminate the need to enter confined spaces for maintenance, repairs, or other purposes. Where confined space entry is unavoidable, it is best to minimize the hazards involved in working in a confined space.

Remove monitor/inspection systems and automated cleaning systems eliminate or minimize the need for confined space entry. Float type tank level indicators are being replaced with non-intrusive radar tank level indicators. Radar indicators are more

accurate than the existing float type tank level indicators. They can measure fluid level to within one inch and are virtually maintenance free. Replacement of float type level indicators with non-intrusive radar indicators helps to eliminate the need for confined space entry inspection.

Other examples of remote monitoring/inspection systems and automated cleaning systems include: use of filters and external pumps to mix the water in tanks or an automated self cleaning system to avoid the build-up of sludge in tanks, and use of self-propelled video inspection units (some rated for use in hazardous locations), telescopic video inspection units, or telescopic valve stems to eliminate the need for confined space draining, purging, and entry during inspections.

Use Materials that Reduce the Need for Maintenance

Designing and selecting equipment should be done on the basis of reducing, even eliminating, worker exposure in confined spaces. Coating systems should be used often.

Provide Adequate Ventilation

Ventilation is one of the most effective means of controlling hazardous atmospheres in confined spaces. Providing adequate ventilation in confined spaces avoids build-up of contaminants or combustible atmospheres. Consider designs that will facilitate ventilation of the space. Ventilation modeling, including finite element analysis, may support designs and configurations that reduce purging time, minimize “dead spots” and facilitate more rapid availability. Factors to consider:

- Clean air replaces contaminated air by natural or forced (mechanical) ventilation.
- Supply fan intake has to be located away from flammable or toxic air.
- Exhaust fan outlets should be positioned to avoid re-circulation of contaminants.
- Diesel exhaust emissions should be prevented from re-circulating into confined spaces.
- Every fuel oil separator should be of efficient design and substantial construction.
- Provisions should be made to prevent overpressure in any fuel oil separator part and to prevent the discharge of oil vapors into confined spaces.

Design Adequate Means of Entry and Exit

Design adequate and convenient means of entry and exit for persons who may be required to wear PPE, a breathing apparatus, and protective clothing. A good example is to have a “butterworth opening” or separate entry hold for all support equipment so personnel are not required to enter through this same access point. Designers should recognize the need for two hatches for spaces into which workers must enter along with the “butterworth hole” for ventilation. Ventilation ducts or hoses should not impede personnel access or exit through hatches. To avoid costly retrofits, include “butterworth” hole and additional hatch designs before loading is calculated and the overall design structure is frozen. The same is true for design of lightening holes in tank baffles and girders. These should be positioned so workers can move from section to section of the tank without undue climbing.

Provide Fall Hazard Protection

To prevent fall hazards in confined spaces, provide fixed ladders, platforms, guardrails, and anchor points for PFASs. Use devices to provide a certified anchor point for attachment of scaffolding or anchorages for PFASs.

Plan for Emergency Rescue

Confined spaces that will be entered by workers should be configured for the removal of injured or unconscious personnel. This means that spaces should be able to handle various stretchers and be configured to accommodate high angle rescue. Adequate hoisting points should be provided for movement of materials and equipment.

Consider Other Design Modifications

Confined space hazards can be further reduced by the following measures:

- Provide suitable illumination, which will be sufficient for safe entry, conducting work, and exiting.
- Provide sufficient room for persons to work in other than stooped or cramped positions.
- Use catalytic converters and ventilation to prevent buildup of carbon monoxide levels in confined spaces.
- Provide a voice or alarm-activated explosion proof type of communication system if visual monitoring of the worker is not available because of the design of the confined space or location of the entry hatch.

Make Improvements in Personal Protective Equipment

In situations where personnel find it necessary to enter a confined space, proper PPE must be used. This may include gas-detection equipment, breathing devices, or protective clothing. Protective clothing, such as chemically resistant coveralls and rubber gloves, can protect personnel entering confined spaces from developing occupational dermatitis or from absorbing toxic hazards (such as fuels) through their skin.

e. Discuss hazards associated with chemical incompatibilities and need for segregation and containment.

The following is taken from the Environment, Health, and Safety Division, Berkeley Lab, Chemical Hygiene and Safety Plan, Chemical Storage.

Chemical storage guidelines are presented below. Use these to segregate and store chemicals according to their hazard class. This prevents an undesirable chemical reaction from occurring should two or more chemicals accidentally mix. Consult sources such as the substance's MSDS for specific storage guidelines.

Acids

Segregate acids from reactive metals such as sodium, potassium, and magnesium.

Segregate oxidizing acids from organic acid and flammable and combustible materials.

Store acetic acid as a flammable liquid. This is an organic (carboxylic) acid that will react if it comes in contact with an oxidizing acid.

Nitric acid and hydrochloric acid may be stored in the same corrosive storage cabinet, but they must be kept in separate drip trays. These can combine to form chlorine and nitrosyl chloride gases—both are toxic.

Segregate acids from chemicals that could generate toxic or flammable gases upon contact, such as sodium cyanide, iron sulfide and calcium carbide.

Segregate acids from bases.

Bases

Segregate bases from acids, metals, explosives, organic peroxides and easily ignitable materials.

Do not store aqueous sodium and potassium hydroxide solutions in aluminum drip trays. These will corrode aluminum.

Solvents (Flammable and combustible liquids)

Store in approved safety cans or cabinets.

Segregate from oxidizing acids and oxidizers.

Keep away from any source of ignition: heat, sparks, or open flames.

Oxidizers

Keep away from combustible and flammable materials.

Keep away from reducing agents such as zinc, alkali metals, and formic acid.

Cyanides

Segregate from aqueous solutions, acids, and oxidizers.

Water-Reactive Chemicals

Store in a cool, dry place, away from any water source.

Make certain that a class D fire extinguisher is available in case of fire.

Pyrophoric Substances

If in original container store in a cool, dry place, making provisions for an airtight seal.

Store in a glovebox after the material has been opened.

Light-Sensitive Chemicals

Store in amber bottles in a cool, dry, dark place.

Peroxide-Forming Chemicals

Most peroxide-forming chemicals are also flammable liquids. Therefore, store in airtight containers in a flammable storage locker.

Segregate from oxidizers and acids.

Toxic Chemicals

Store according to the nature of the chemical, using appropriate security where necessary.

Chemical Incompatibility Table

Table 22 is another resource for determining chemical incompatibilities. This is not exhaustive. Therefore, use sources such as MSDSs to determine chemical incompatibility. The container's label should also provide storage guidelines.

Table 22. Chemical incompatibilities

Chemical	Keep Out of Contact With
Acetic acid	Chromic acid, nitric acid, hydrozyl compounds, ethylene glycol, perchloric acid, permanganates, and other oxidizers
Acetone	Concentrated nitric and sulfuric acid mixtures, and strong bases
Acetylene	Chlorine, bromine, copper, fluorine, silver mercury
Alkali metals	Water, carbon tetrachloride or other chlorinated hydrocarbons, carbon dioxide, halogens
Ammonia, anhydrous	Mercury chlorine, calcium hypochlorite, iodine, bromine, hydrofluoric acid
Ammonium nitrate	Acids, metal powders, flammable liquids, chlorates, nitrites, sulfur, finely divided organic or combustible materials
Aniline	Nitric acid, hydrogen peroxide
Arsenic materials	Any reducing agent
Calcium oxide	Water
Carbon (activated)	Calcium hypochlorite, all oxidizing agents
Carbon tetrachloride	Sodium
Chlorates	Ammonium salts, acids, metal powders, sulfur, finely divided organic or combustible materials
Chromic acid and chromium trioxide	Acetic acid, naphthalene, camphor, glycerol, glycerin, turpentine, alcohol, flammable liquids in general
Copper	Acetylene, hydrogen peroxide
Flammable liquids	Ammonium nitrate, chromic acid, hydrogen peroxide, nitric acid, sodium peroxide, halogens
Hydrocarbons	Fluorine, chlorine, bromine, chromic acid sodium peroxide
Iodine	Acetylene, ammonia, hydrogen
Mercury	Acetylene, fulminic acid, ammonia
Nitrates	Sulfuric acid
Nitrites	Acids
Nitroparaffins	Inorganic bases, amines
Oxalic acid	Silver, mercury
Perchloric acid	Acetic anhydride, bismuth and its alloys, alcohol, paper, wood, grease, and oils
Peroxides, organic	Acids (organic or mineral), avoid friction, store cold
Phosphorus (white)	Air, oxygen, alkalis, reducing agents
Potassium	Carbon tetrachloride, carbon dioxide, water
Potassium chlorate and perchlorate	Sulfuric and other acids
Potassium permanganate	Blycerin, ethylene glycol, benzaldehyde, sulfuric acid
Selenides	Reducing agents
Silver	Acetylene, oxalic acid, tartatic acid, ammonium compounds, fulminic acid
Sodium	Carbon tetrachloride, carbon dioxide, water
Sulfides	Acids
Tellurides	Reducing agents

Source: Berkeley Laboratory, The Environment, Health, and Safety Division, *Chemical Hygiene and Safety Plan, Chemical Storage Guidelines*

f. Discuss first aid and emergency response considerations for operations involving hazardous chemicals.

The following is taken from 29 CFR 1910.120.

For operations involving hazardous chemicals, the employer shall develop an emergency response plan for emergencies which shall address, at a minimum, the following:

- Pre-emergency planning and coordination with outside parties
- Personnel roles, lines of authority, training, and communication
- Emergency recognition and prevention
- Safe distance and places of refuge
- Site safety and control
- Evacuation routes and procedures
- Decontamination procedures which are not covered by the site safety and health plan
- Emergency medical treatment and first aid
- Emergency alerting and response procedures
- Critique of response and follow-up
- PPE and emergency equipment

First aid should be performed according to the appropriate chemical MSDS.

g. Describe methods by which toxic compounds may enter the body and the control mechanisms available to block these routes of entry.

The following is taken from the Department of Health and Human Services, ATSDR, A Toxicology Curriculum for Communities Trainer's Manual.

Table 23 covers the three primary methods by which toxic compounds may enter the body and the control mechanisms available to block these routes of entry.

Table 23. Primary methods of entry

Method	Description	Control Mechanisms
Inhalation	Inhalation is the easiest and fastest means of exposure to toxic substances because toxic substances are readily absorbed in the respiratory tract.	A number of mechanisms protect the lungs, such as simple coughing, or cleansing by “macrophages” that engulf and promote the removal of anything foreign.
Absorption	Contact with the skin is the most common path of toxic substance exposure. Physical damage to the skin allows toxic substances to penetrate the epidermis and enter the dermis where they more readily enter the bloodstream and are carried to other parts of the body.	Materials entering the circulatory system (arteries, veins, etc.) can be detoxified in the liver or excreted through the kidneys.
Ingestion	Ingestion of toxic substances usually occurs accidentally or unknowingly. The digestive tract consists of the mouth, the esophagus, stomach, and intestines. The major function of the digestive tract is to digest and absorb the foods we eat.	Excretion through urine, the kidneys, the lungs, and liver are important in removing chemicals from the body. The kidney eliminates the greatest number of toxins, the lungs eliminate substances in the gaseous phase; but the liver removes substances by excreting them into bile, which is made by the liver and travels to the small intestine. From there the substance can be absorbed in the feces and then eliminated through excretion.

Source: Department of Health and Human Services, ATSDR, *A Toxicology Curriculum for Communities Trainer’s Manual*

h. Discuss the following terms mixture, solvent, solubility, solute, solution, equilibrium.

The following definitions are taken from DOE-HDBK-1015/1-93 unless stated otherwise.

Mixture

Mixtures consist of two or more substances intermingled with no constant percentage composition. Each component retains its original properties. When a teaspoon of sugar is added to a glass of water, it will slowly dissolve into the water and disappear from view. As a result, the molecules of sugar are evenly distributed throughout the water and become mixed with the water molecules. Because the sugar and water mixture is uniform throughout, it is said to be homogeneous.

Solvent

All solutions consist of a solvent and one or more solutes. The solvent is the material that dissolves the other substance(s). It is the dissolving medium. In the water-sugar solution, the water is the solvent. The substances that dissolve in the solution are called solutes. In the water-sugar solution, sugar is the solute.

Solubility

Solubility is defined as the maximum amount of a substance that can dissolve in a given amount of solvent at a specific temperature. At this point, the solution is said to be saturated. A solution is saturated when equilibrium is established between the solute and the solvent at a particular temperature.

Solute

The substances that dissolve in the solution are called solutes. In the water-sugar solution, sugar is the solute.

Solution

A homogeneous mixture of two or more substances is called a solution. The reason solutions are classified as mixtures rather than as compounds is because the composition is not of fixed proportion.

Equilibrium

A solution is saturated when equilibrium is established between the solute and the solvent at a particular temperature. Equilibrium is the point at which the rates of the forward and reverse reactions are exactly equal for a chemical reaction if the conditions of reaction are constant.

i. Analyze processes or operations to identify potential chemical hazards and appropriate control measures.

This is a performance based KSA. The Qualifying Official will evaluate its completion.

j. Discuss use of and considerations regarding chemical monitoring and sampling techniques.

The following is taken from Washington State University, Environmental Health and Safety (EH&S), Fact Sheet: Chemical Monitoring and Sampling.

Environmental health and safety monitoring and sampling results are used to determine the need for engineering controls or PPE and ensure compliance with regulatory standards.

Environmental health and safety uses a variety of sampling and monitoring equipment when evaluating air contaminants because current technology does not offer a “single” instrument that can detect everything that may be present in the air.

Generally, there are two situations when EH&S receives requests to monitor or sample. One is when someone wants to know the chemical exposure levels during a specific process. The other situation is when someone wants to know “What is that smell?” or “What is in the air?” These two situations require different approaches.

Evaluating a specific process for air contaminants is the easier of the two because EH&S

- knows what chemicals need to be monitored/sampled;
- has the time to evaluate the process and determine the monitoring instrument, proper sampling media and protocol; and
- can obtain sampling media (stock or order) in a reasonable time.

Determining “What is that smell?” or “What’s in the air?” is not as easy. While people asking these questions may want answers immediately, these situations normally take additional time.

- Although EH&S has several direct reading instruments for specific chemicals and sampling media for chemicals routinely used, there is no single, universal sampling/monitoring instrument available.
- The source of the contaminants is unknown, and an investigation is needed to determine what contaminants need to be sampled or monitored, what instrumentation is to be used, and the sampling protocol.
- Uncertainty of when the sampling media will be needed and the associated expiration dates, make it impossible to keep all types of media in stock.
- There are times when identifying contaminant(s) to monitor/sample is extremely difficult. EH&S obtains monitoring/sampling results by either
 - retrieving information from a direct reading instrument. Air contaminants are sampled and analyzed within the instrument in a relatively short time (seconds to minutes).
 - sending the sample media to an accredited lab. The results may be available within a couple of days to several weeks.

Once obtained, results are compared to regulatory limits and recommended levels. If the monitoring/sampling results show levels above regulatory limits, EH&S will work with the department to control the exposure.

Occupational exposures can be controlled through substitution of a less hazardous material, ventilation, enclosures, equipment maintenance, process changes, and/or PPE (last resort). To determine if the controls are effective, EH&S can conduct additional monitoring/sampling. Employees and students monitored will receive copies of the results. Results below established limits and recommendations may still produce symptoms similar to those indicated on the MSDS. This may be due to a wide variation in individual susceptibility. A small percentage of people may experience discomfort from some substances at concentrations at or below the established limits or recommendations. These effects are usually minor and brief with no long term effects.

An even smaller percentage of people may experience more prolonged symptoms because of pre-existing conditions. For example, individuals may be sensitive or otherwise unusually responsive to some chemicals because of genetic factors, age, medications, or previous exposure. In these situations, it is recommended that EH&S and an occupational physician be consulted.

k. Discuss major elements of a hazard communication program, laboratory safety program, and process safety management program.

Hazardous Communication Program

The following is taken from 29 CFR 1910.1200.

This occupational safety and health standard is intended to address comprehensively the issue of evaluating the potential hazards of chemicals, and communicating information concerning hazards and appropriate protective measures to employees, and to preempt any legal requirements of a state, or political subdivision of a state, pertaining to this subject.

Evaluating the potential hazards of chemicals, and communicating hazards and appropriate protective measures to employees, may include, for example, but is not limited to, provisions for: developing and maintaining a written hazard communication program for the workplace, including lists of hazardous chemicals present; labeling of containers of chemicals in the workplace, as well as of containers of chemicals being shipped to other workplaces; preparation and distribution of MSDSs to employees and downstream employers; and development and implementation of employee training programs regarding hazards of chemicals and protective measures.

Laboratory Safety Program

The following is taken from 29 CFR 1910.1450.

The employer shall provide employees with information and training to ensure that they are apprised of the hazards of chemicals present in their work area.

Such information shall be provided at the time of the employee's initial assignment to a work area where hazardous chemicals are present and prior to assignments involving new exposure situations. The frequency of refresher information and training shall be determined by the employer.

Employees shall be informed of

- the contents of 29 CFR 1910.1450, "Occupational Exposure to Hazardous Chemicals in Laboratories," and its appendices which shall be made available to employees;
- the location and availability of the employer's chemical hygiene plan;
- the PELs for OSHA-regulated substances or recommended exposure limits for other hazardous chemicals where there is no applicable OSHA standard;
- signs and symptoms associated with exposures to hazardous chemicals used in the laboratory; and
- the location and availability of known reference material on the hazards, safe handling, storage, and disposal of hazardous chemicals found in the laboratory including, but not limited to, MSDSs received from the chemical supplier.

Employee training shall include

- methods and observations that may be used to detect the presence or release of a hazardous chemical;
- the physical and health hazards of chemicals in the work area;

- the measures employees can take to protect themselves from these hazards, including specific procedures the employer has implemented to protect employees from exposure to hazardous chemicals, such as appropriate work practices, emergency procedures, and PPE to be used; and
- training on the applicable details of the employer's written chemical hygiene plan.

Process Safety Management Program

The following is taken from 29 CFR 1910.119.

The employer shall complete a compilation of written process safety information before conducting any PrHA required by 29 CFR 1910.119, "Process Safety Management of Highly Hazardous Chemicals." The compilation of written process safety information is to enable the employer and the employees involved in operating the process to identify and understand the hazards posed by those processes involving highly hazardous chemicals. This process safety information shall include information pertaining to the hazards of the highly hazardous chemicals used or produced by the process, information pertaining to the technology of the process, and information pertaining to the equipment in the process.

Information pertaining to the hazards of the highly hazardous chemicals in the process shall consist of at least the following:

- Toxicity information
- Permissible exposure limits
- Physical data
- Reactivity data
- Corrosivity data
- Thermal and chemical stability data
- Hazardous effects of inadvertent mixing of different materials that could foreseeably occur

Information concerning the technology of the process shall include at least the following:

- A block flow diagram or simplified process flow diagram
- Process chemistry
- Maximum intended inventory
- Safe upper and lower limits for such items as temperature, pressures, flows or compositions
- An evaluation of the consequences of deviations, including those affecting the safety and health of employees

Where the original technical information no longer exists, such information may be developed in conjunction with the PrHA in sufficient detail to support the analysis.

Information pertaining to the equipment in the process shall include

- materials of construction
- piping and instrument diagrams
- electrical classification
- relief system design and design basis
- ventilation system design
- design codes and standards employed
- material and energy balances for processes built after May 26, 1992
- safety systems

The employer shall document that equipment complies with recognized and generally accepted good engineering practices.

For existing equipment designed and constructed according to codes, standards, or practices that are no longer in general use, the employer shall determine and document that the equipment is designed, maintained, inspected, tested, and operating in a safe manner.

24. Personnel must demonstrate a familiarity level knowledge of basic material science.

a. Discuss the following terms: compressibility, stress, shear, tensile strength, yield strength, and fatigue.

The following definitions are taken from DOE-HDBK-1017/1-93.

Compressibility

Compressibility is the ability of a material to react to compressive stress or pressure.

Stress

Stress is the internal resistance of a material to the distorting effects of an external force or load.

Shear

Shear stress exists when two parts of a material tend to slide across each other upon application of force parallel to that plane.

Tensile Strength

The ultimate tensile strength is the maximum resistance to fracture. It is equivalent to the maximum load that can be carried by one square inch of cross-sectional area when the load is applied as simple tension. It is expressed in pounds per square inch (psi).

Yield Strength

The yield strength is defined as the stress at which a predetermined amount of permanent deformation occurs.

b. Discuss the terms prestressed concrete, reinforcing bars, post tension.

The following is taken from Portland Cement Association, Cement and Concrete Basics.

Prestressed Concrete

In conventional reinforced concrete, the high tensile strength of steel is combined with concrete's great compressive strength to form a structural material that is strong in both compression and tension. The principle behind prestressed concrete is that compressive stresses induced by high-strength steel tendons in a concrete member before loads are applied will balance the tensile stresses imposed in the member during service.

Prestressing removes a number of design limitations conventional concrete places on span and load and permits the building of roofs, floors, bridges, and walls with longer unsupported spans. This allows architects and engineers to design and build lighter and shallower concrete structures without sacrificing strength.

Reinforcing Bars

The following is taken from Concrete Reinforcing Steel Institute, *Reinforcing Bars: Embedded Strength of Reinforced Concrete*.

Steel reinforcing bars are produced by pouring molten steel into casters and then running it through a series of stands in the mill, which shape the steel into reinforcing bars. The cross hatchings, called deformations, help secure the steel and transfer the load between it and the concrete.

For buildings, bridges, highways, and runways, the cast-in-place concrete body and shop-fabricated steel musculature of reinforcing bars work in tandem to create one of the most durable and most economical composite materials.

Reinforced concrete is composite material. The concrete provides the material's compressive strength, while the steel—in the form of embedded reinforcing bars—provides tensile strength.

Post Tension

The following is taken from Portland Cement Association, *Post-Tensioned Concrete*.

Pre-tensioning is a method of prestressing in which the tendons are tensioned before concrete is placed and the prestressing force is primarily transferred to the concrete through bond. Post-tensioning is a method of prestressing in which the tendons are tensioned after the concrete has hardened and the prestressing force is primarily transferred to the concrete through the end anchorages.

Unlike pre-tensioning, which can only be done at a precast manufacturing facility, post-tensioning is performed on the jobsite in cast-in-place applications. The concrete component is cast with steel reinforcing strands installed in a way that protects them from bonding with the concrete. This practice gives designers the flexibility to further optimize material use by creating thinner concrete members.

The materials used to post-tension concrete members are ultra-high-strength steel strands and bars. Horizontal applications typically employ strands. Walls, columns, and other vertical applications usually utilize bars. Steel strands used for post-tensioning typically have a tensile strength of 270,000 psi, are about a half-inch in diameter, and are stressed to a force of 33,000 pounds.

c. Describe the adverse effects of welding on metal, including the types of stress.

The following is taken from Fabricator's and Manufacturer's Association, *Welding Effects on Strengthening Steel*.

Welding can severely influence strengthened or hardened metals, depending on the hardening technique used. Because of this, post-weld heat treatment is often very helpful in maintaining weld joint strength because it softens or tempers any martensite or bainite that formed in the heat-affected zone (HAZ).

Work- or strain-hardened metals exposed to the intense localized heat of welding tend to recrystallize and soften in the HAZ. Assuming the correct filler metal is used, the only area affected is the HAZ. The admixture and filler metal do not suffer recrystallization

and remain as strong as the base metal. This explains why, when dealing with work- or strain-hardened steel, failures usually happen in the HAZ right next to the weld joint, not directly in the joint.

This is especially true for cold-rolled steel, wrought iron, and drawn or rolled aluminum. When working with these materials, joint design is critical, and the amount of stress the finished piece will experience in service must be taken into account.

Precipitation-hardened metals go through a more complex change than work-hardened metals do, but the end result is similar, with the HAZ going through an annealing cycle and becoming softer. That is because the precipitate that gives the metal its strength grows and agglomerates with heat—it over-ages. This reduces the effects of precipitation hardening. The higher the heat, the faster the metal reaches the over-aged, or weakened, state. Post-weld heat treatment can correct this, as long as the filler metal to match the base metal's aging characteristics is carefully selected.

Metals that have been solid-solution-hardened have the least amount of change when welded. There is a little grain growth at the fusion line, but usually not enough to have any effect on the metal's properties.

Transformation-hardened metals react much like solid-solution-hardened metals, assuming they have enough hardenability to form martensite during heat treatment or have formed martensite in previous heat treatments. A temperature profile of a transformation-hardened metal identifies four basic regions in the HAZ, with heat input determining both the width of the HAZ and the width of each region.

The higher the heat input, the wider the HAZ and the slower the cooling rate. Slower cooling rates are less likely to form martensitic regions. Consequently, you can reduce post-weld brittleness by preheating to slow the cooling rate, although you may also have to post-heat the weld to slow cooling further. This also means that the harder the HAZ, the more martensite, and the more martensite, the greater the chance for cracking.

d. Describe how extremes in temperature, pressure, and other environmental factors affect material performance for metal, soils, plastics, and glass.

The following is taken from National Research Council Canada, CBD-115, Performance of Building Materials.

Building materials must serve their intended function not only when newly installed but also for some acceptable length of time. This service life may last for the life of the building or, as with paints, for only a few years before renewal.

It is common to speak of the durability of a material as if it were a basic property, measured as the length of time it will serve satisfactorily. The useful life of a material in place, however, is always related to the particular combination of environmental factors to which it is subjected, so that durability, or service life, must always be related to the particular conditions involved.

Experience with traditional materials over many years permits prediction of the performance of the same material under similar conditions. Such trial by use has provided an answer to how but not often to why materials react as they do. When new materials are

to be developed or considered or when traditional materials are to be used in untried situations, the ability to predict performance may be greatly limited unless the “why” of past experience, and thus the fundamental factors involved, are understood. This is basic to the exercise of judgment in design, a combination of experience and analysis. Such an approach is also necessary in the development and interpretation of any accelerated test method designed to improve prediction of performance.

Most building materials are complex in their chemical and physical nature, as are the processes involved in their response to environmental factors. Some generalizations may be made in these respects, however, that will improve understanding of performance and provide a basis for predicting behavior.

Chemical Nature

The chemical nature of a material is seldom meaningful to the material user or specifier because he does not understand its implications. It is its chemical nature, however, that determines the reactivity of a material to other materials and to some elements of the environment. Thus it is a dominant factor in its stability and durability. For this reason the designer needs a sense of chemistry to appreciate the basic differences in the classes and types of materials. It is especially significant that small changes in composition (even trace amounts of some substances, as with metal alloys) can have a profound influence on the resulting properties.

An appreciation of the basic constitution of the main classes of materials becomes most significant when it can be associated with certain behavior. For example, the influence of UV radiation on organic materials can be appreciated when it is known that the organic molecule has bonds that can be broken and that other changes can be induced through the action of this radiation. This does not happen with metals or cementitious materials. These, however, have other special characteristics, as for hydrates such as gypsum plaster that are unstable at relatively moderate temperature conditions and can undergo decomposition at low relative humidity. These examples but emphasize the importance of the chemical nature of a material, providing, in the first instance, guidelines for expected behavior or performance for a given use.

Physical and Mechanical Nature

It is customary in structural design to consider a material in terms of the practical unit in the total structure, whether it be a beam, column, or plate. The engineering properties being given in terms of the bulk material, the assumption is made that the material is homogeneous and isotropic on a scale that is significant in the proposed design. This manner of thinking about a material does not allow for an understanding of its behavior because at this scale the factors that determine the response of the material itself cannot be appreciated. It is like considering the response of a steel bridge to a given load without being able to analyze the stress in any one member. The bridge may carry a certain load, but it will fail in time if one member is overstressed.

To understand the physical and mechanical behavior of a material it is necessary to think in terms of a model of the material that will give a physical representation of the system and describe its average chemical, physical and mechanical properties. On this basis, consideration must be given to the grain, crystallite or polymer molecules, the assemblage of these into the many geometric arrangements that occur, the space or

porosity around the units, and the nature and extent of the bonds, which are the forces that hold these building blocks together.

It is useful, therefore, to think of the material on the scale of its microstructure. In considering deteriorating processes, the broad classification of porous and non-porous is useful for identifying where the effect is to be expected.

Non-Porous Materials. Non-porous materials include the large group classed as metals and ceramics. They are polycrystalline and characterized by continuous grain boundaries. Any reaction with environmental factors is initiated at the external surface, as with corrosion of metal, and the grain boundaries often provide the weak area along which action proceeds inward from the outer face. In most instances a surface coating will provide adequate protection against reaction with the environment if the material itself is not resistant.

Polymers represent another group of non-porous materials that are generally amorphous and chemically characterized by their large molecular size. They are formed by polymerization or joining up of simple molecules, which are either gases or volatile liquids. For example, butane differs chemically from polyethylene only in the size of the molecule.

The chief characteristic of this group of materials is plasticity. Deformations of 100 percent are possible before failure. This occurs partly because of their amorphous nature, where large chain-like organic molecules are randomly oriented and held together by physical forces of attraction, and partly because at normal temperature they are in a state that would correspond to near-melting temperature in metals. Polymers become more like plaster or glass when temperature is lowered.

Porous Materials. Most naturally occurring materials and those classed as cementitious materials formed by hydration or other chemical reactions of inorganic constituents are porous in the sense that they contain spaces around crystallites or grains that are interconnected. These spaces are usually of varying size and shape, and the interconnecting channels are often extremely small and tortuous. It is of great importance to distinguish between pores that are interconnected and communicate to the outside environment of the material and those that are essentially isolated bubbles inside a matrix of the material. The reasons for this are obvious: when the pores communicate to the outside, the surface area of the material is potentially the total surface of the pore space.

Because reactions with environment begin at the surface a material with a greater surface area is liable to attack in proportion to its increased surface area.

Total porosity is the most important parameter when considering the microstructure. It has a great effect upon strength but, more important, it provides the reservoir for water which can undergo freezing with corresponding dilation, or a medium for dissolution of constituents for reactions with foreign substances from the atmosphere. It is not generally appreciated that the total porosity of many practical materials is so large. Normal plaster can have a porosity over 50 per cent by volume, and concrete can be equally porous in extreme cases.

Environmental Factors

Environment can be defined as the combined effect of a number of factors that interact with the material: temperature, moisture, solar radiation, foreign matter. Although these can often be measured separately and recorded quantitatively against basic standards, their significance to the performance of a material lies in the degree of their interaction with the material. The material responds to actual temperature and its variation inside the material. This may be quite different from the temperature of the air surrounding the material because of thermal lag and radiant heat loss or gain.

Moisture content, its variation through the material, and the range in the cycle from wet to dry or the reverse, will depend on a combination of factors including rainfall, wind, humidity, and other factors pertaining to the physical nature of the material, as well as to its location with respect to other components. Again, what matters in determining performance is the moisture content and its change in the material.

The ultraviolet component of solar radiation is important in the deterioration process of organic materials only in the degree to which the chemical nature of the material permits interaction and the relative amount of radiation that reaches it. This is determined by its orientation and location in the structure.

Foreign matter is defined as any substance or agent that comes in direct contact with a given material. It may be a gas, liquid, bacteria, fungus, animal or insect, or even another component of the same structure. A material may interact with its neighbor or with a constituent from the environment to produce a change in properties.

Because environmental factors act in combinations and go through daily and seasonal cycles, imposing constantly changing conditions, the result is a most complex set of variables that controls the successive or simultaneous chemical and physical processes responsible for changes in materials. This makes identification of the processes or factors responsible for failure extremely difficult.

Chemical and Physical Processes

Aging

Many materials undergo slow chemical and physical changes referred to as aging for some period after their manufacture. These changes may involve the completion of some of the reactions of forming or the reverse reactions when the material tries to adjust to conditions of storage or service. Such changes are often difficult to differentiate from changes involving weathering processes.

Many organic materials such as plastics and sealants undergo aging. Plastic floor tile often shrinks for a period after manufacture; and freshly fired brick or clay tile also may undergo dimensional changes in storage while adjusting to new conditions of moisture content.

Efflorescence and Crystallization of Soluble Salts

Basically, this process involves soluble salts from either the materials themselves or pollution sources in the atmosphere. The salts are dissolved and moved by the free water in the pores of the material to the surface where the water evaporates, leaving the salts in the form of a stain called efflorescence. When evaporation occurs in cracks or cavities in

the material the result may be an expansive force that tends to separate the neighboring materials. Because of this action of crystallizing salts the process has often been linked with frost action, where water in the pores of material crystallizes to ice, also with an expansive force. Any given failure in a material, therefore, cannot be simply diagnosed as caused by one or the other of these processes.

Although it is known that the process of crystallization involves soluble salts and water in the material, the mechanism of the action in the pores of the material is not understood well enough to permit prediction by suitable tests and enable adequate control. The best safeguard is to prevent entry of water into the material.

Frost Action

The freezing of water in porous materials is perhaps the most important cause of weathering of materials. Frost failure occurs only in materials that are frequently frozen when very wet, and much effort has been made to establish a criterion for the degree of wetness at which a material becomes susceptible to frost action. Various combinations of structural parameters such as saturation coefficient and porosity have been found helpful in assessing frost-resistance of some materials, especially stone, but no single parameter or combination of parameters has yet been found that will accurately indicate the frost-resistance of all porous building materials. This emphasizes present lack of understanding of this process.

It is known that materials having high porosity and small pores are generally more susceptible; and that alternate cycles of freezing and thawing and high rates of freezing contribute to rapid destruction by frost action in a material close to or at saturation.

Wetting and Drying Movement and Thermal Movement

It is a common experience that materials move with changes in moisture content and changes in temperature. If the material in a structure is homogeneous and changes in moisture and temperature occur more or less uniformly throughout the bulk of the material, very large movements can be accommodated without failure. Changes in moisture content and temperature involving gradients that result in stresses within the material, however, can cause cracking as is the case with drying shrinkage of concrete. Cracks may also form because of stresses resulting from combining dissimilar materials.

Although cracks caused by moisture and thermal movements do not always cause failure by themselves, they often serve as openings through which more rain can enter the structure, making it easy for other processes of salt crystallization and frost action to take place.

e. Describe facility and system degradation due to natural phenomenon hazards (NPH), fires, impact, and chemical insults.

Fires

The following is taken from Westinghouse Hanford Corporation, WHC-SD-GN-FHA-30001 Rev, 0.

The maximum possible fire loss is initially based on the effect of one or more uncontrolled fire events in the facility. This provides direction as to the need for automatic, redundant, and passive fire protection systems as described below:

- When the MPFL exceeds \$1 million, a complete automatic suppression system designed in accordance with applicable NFPA standards shall be provided.
- When the MPFL exceeds \$50 million, a redundant fire protection system is provided that, despite the failure of the primary system, will limit the loss to \$50 million.
- When the MPFL exceeds \$150 million, a redundant fire protection system and 3-hour fire barrier(s) are required to limit the loss to \$150 million.

The final MPFL is calculated without regard to automatic or redundant fire protection systems recommended by the FHA or referenced from supporting documentation.

Impacts

The following is taken from DOE G 420.1-2.

Structures, systems and components (SSCs) should be designed, constructed, and operated to withstand the effects of natural phenomena as necessary to ensure the confinement of hazardous material, the operation of essential facilities, the protection of government property, and the protection of occupants of DOE buildings. The design and evaluation process should consider potential damage and failure of SSCs due to direct natural phenomena effects, including common cause, and indirect natural phenomena effects, including interaction with other SSCs.

Examples of interaction include the following:

- Failure of an SSC, which falls on an SSC important to safety or mission
- Impact damage due to displacements of adjacent SSCs
- Displacements of adjacent SSCs resulting in failure of connecting pipes or cables
- SSCs (such as lighting, communication systems, access hallways and doors) whose failure following natural phenomena events could hinder necessary operator actions
- Flooding and exposure to fluids from vessels or piping systems ruptured during a natural phenomena event
- Offsite natural phenomena effects on the facility, such as NPH-induced loss of offsite power and failure of upstream dams and reservoirs
- Effects of natural phenomena-induced fires

Common Cause Effects. The occurrence of a natural phenomena event, especially earthquake, affects many or all SSCs in a facility or across an entire site. Hence, it is possible to have multiple natural phenomena-induced failures of SSCs. These common cause effects must be considered in design or evaluation. For example, multiple failures in a tank farm can result in loss of contents greater than that held in any single tank. The effects of this large quantity of tank contents on SSCs must be considered.

Chemical Insults

The following is taken from National Research Council Canada, CBD-115, Performance of Building Materials.

Changes in materials, both beneficial and destructive, can occur as a result of chemical processes. These can involve interaction with water or foreign matter from the environment or with neighboring materials. Corrosion of metals, alkali-aggregate

reactions in concrete, sulphate attack on concrete, weathering of stone and mortar by the action of rain water acidified by the sulphur gases in the air, and photochemical reactions involving UV light from sunlight and organic materials are but a few of the more common reactions.

For chemical reaction to take place the ingredients must come into contact, usually through a common medium such as water. Thus, if materials are kept dry much of the chemical attack can be stopped. Reactions usually occur at the surface, so that a highly porous stone is much more subject to attack by sulphur gases than less porous stone. Where porosity involves only very small channels, as with dense concrete, the rate of transfer of water and solution may be so slow that for practical purposes the internal surface is not available for reaction with external agents.

Temperature also is an important factor. A useful guide is that the reaction rate doubles with every 10-degree centigrade rise in temperature.

Chemical attack, in the first place, alters the properties of the parent material, but in the process it also produces products that may occupy a larger volume. The result is a dilating pressure that may initiate cracks in the material. These cracks will accelerate the progress of other destructive processes so that in the end the material may deteriorate by a number of chemical and physical processes. It is this aspect that makes analysis of failure very difficult.

25. Occupational safety personnel must demonstrate a familiarity level knowledge of the nuclear safety and radiological safety interfaces with occupational safety.

a. Discuss the applicability of occupational safety and health criteria in DOE Orders to nuclear safety.

The following is taken from DOE O 452.2D.

The Office of Safety provides independent oversight of the implementation of DOE O 452.2D, *Nuclear Explosive Safety*, and associated manuals by NNSA personnel. This oversight may be carried out through observation of nuclear explosive safety (NES) evaluations, independent assessments, or other appropriate mechanisms. On an annual basis, the Office of Safety will summarize its oversight activities, along with any recommendations for changes in the NES program in a report to the Assistant Deputy Administrator for Nuclear Safety Operations and the Assistant Deputy Administrator for Science, Engineering and Production Programs.

The following is taken from DOE O 410.1.

DOE O 410.1, *Central Technical Authority Responsibilities Regarding Nuclear Safety Requirements*, establishes CTA and Chief of Nuclear Safety/Chief of Defense Nuclear Safety responsibilities and requirements directed by the Secretary of Energy in the development and issuance of DOE regulations and directives that affect nuclear safety.

b. Describe the potential impact of nuclear safety requirements on occupational safety matters and discuss the need for coordination between occupational safety functional area professionals, and health physicists, nuclear safety, and other involved parties.

The following is taken from DOE-STD-6005-2001.

DOE and contractor line management are required to coordinate industrial hygiene efforts with cognizant occupational medical, environmental protection, health physics, and work planning professionals.

Coordination must be established, maintained, and documented between the industrial hygiene staff and other worker protection and organizational functions in the facility to ensure the successful implementation and efficacy of the Worker Protection Program. These functions include, but are not limited to: occupational medicine, epidemiology, industrial safety, environmental protection, fire protection, health physics, purchasing, maintenance, engineering, operations, contracting, quality assurance, and employee groups and recognized bargaining units. For example, the senior industrial hygienist may recommend employees to be included in medical surveillance and should participate in the review of occupational exposure and medical surveillance data.

c. Discuss the safety and analysis process used to develop a documented safety analysis (DSA).

The following is taken from DOE G 421.1-2.

The safety analysis should consist of a PrHA that identifies the types and magnitudes of hazards that are anticipated in the facility. From this, the appropriate nuclear safety design criteria should be identified, and at least a top-level description should be given of how these criteria will be met in the design. The rule requires that contractors either use the nuclear safety design criteria in DOE O 420.1B or propose alternative criteria for DOE approval. In addition, 10 CFR 835, Subpart K, "Occupational Radiation Protection," gives regulatory requirements for design and control. Contractors should also consult the guidance for DOE O 420.1B.

d. Describe the radiation protection program per 10 CFR 835 and how instrumentation and monitoring support selection of radiological safety controls.

The following is taken from 10 CFR 835.402.

For the purpose of monitoring individual exposures to external radiation, personnel dosimeters shall be provided to and used by the following:

- Radiological workers who, under typical conditions, are likely to receive one or more of the following:
 - An effective dose of 0.1 rem (0.001 Sv) or more in a year
 - An equivalent dose to the skin or to any extremity of 5 rems (0.05 Sv) or more in a year
 - An equivalent dose to the lens of the eye of 1.5 rems (0.015 Sv) or more in a year
- Declared pregnant workers who are likely to receive from external sources an equivalent dose to the embryo/fetus in excess of 10 percent of the applicable limit

- Occupationally exposed minors likely to receive a dose in excess of 50 percent of the applicable limits in a year from external sources
- Members of the public entering a controlled area likely to receive a dose in excess of 50 percent of the limit in a year from external sources
- Individuals entering a high or very high radiation area

External dose monitoring programs implemented to demonstrate compliance shall be adequate to demonstrate compliance with the dose limits and shall be

- accredited, or excepted from accreditation, in accordance with the DOE Laboratory Accreditation Program for Personnel Dosimetry; or
- determined by the secretarial officer responsible for ES&H matters to have performance substantially equivalent to that of programs accredited under the DOE Laboratory Accreditation Program for Personnel Dosimetry.

For the purpose of monitoring individual exposures to internal radiation, internal dosimetry programs shall be conducted for

- radiological workers who, under typical conditions, are likely to receive a committed effective dose of 0.1 rem (0.001 Sv) or more from all occupational radionuclide intakes in a year;
- declared pregnant workers likely to receive an intake or intakes resulting in an equivalent dose to the embryo/fetus in excess of 10 percent of the limit;
- occupationally exposed minors who are likely to receive a dose in excess of 50 percent of the applicable limit from all radionuclide intakes in a year; or
- members of the public entering a controlled area likely to receive a dose in excess of 50 percent of the limit from all radionuclide intakes in a year.

The following is taken from 10 CFR 835.403.

Monitoring of airborne radioactivity shall be performed

- where an individual is likely to receive an exposure of 40 or more DAC-hours in a year; or
- as necessary to characterize the airborne radioactivity hazard where respiratory protective devices for protection against airborne radionuclides have been prescribed.

Real-time air monitoring shall be performed as necessary to detect and provide warning of airborne radioactivity concentrations that warrant immediate action to terminate inhalation of airborne radioactive material.

The following is taken from 10 CFR 835.1001.

Measures shall be taken to maintain radiation exposure in controlled areas ALARA through engineered and administrative controls.

The primary methods used shall be physical design features (e.g., confinement, ventilation, remote handling, and shielding). Administrative controls shall be employed only as supplemental methods to control radiation exposure.

For specific activities where use of engineered controls is demonstrated to be impractical, administrative controls shall be used to maintain radiation exposures ALARA.

The following is taken from 10 CFR 835.1101.

Material and equipment in contamination areas, high contamination areas, and airborne radioactivity areas shall not be released to a controlled area if

- removable surface contamination levels on accessible surfaces exceed the removable surface contamination values specified in appendix D of 10 CFR 835; or
- prior use suggests that the removable surface contamination levels on inaccessible surfaces are likely to exceed the removable surface contamination values specified in appendix D of 10 CFR 835.

Material and equipment exceeding the removable surface contamination values specified in appendix D of 10 CFR 835 may be conditionally released for movement onsite from one radiological area for immediate placement in another radiological area only if appropriate monitoring is performed and appropriate controls for the movement are established and exercised.

Material and equipment with fixed contamination levels that exceed the total contamination values specified in appendix D of 10 CFR 835 may be released for use in controlled areas outside of radiological areas only under the following conditions:

- Removable surface contamination levels are below the removable surface contamination values specified in appendix D of 10 CFR 835.
- The material or equipment is routinely monitored and clearly marked or labeled to alert personnel of the contaminated status.

e. Explain the use of radiological work permits and how this permit is part of a work control process.

The following is from the Lawrence Berkeley National Laboratory, Publication 3000.

Radiological work permits (RWPs) are a type of radiological authorization issued for short-term or nonroutine projects and/or specific scopes of work that have a radiological hazard element and are not captured by other radiological authorizations. The RWP document informs workers of the radiological controls, limitations, training/entry requirements, hold points, engineering controls, radiological sampling, and other measures necessary for a specific scope of work and each work activity within a project. The RWPs may supplement, or be independent of, other radiological authorizations and are valid only for the duration and scope of the project.

f. Discuss how a radiation protection program and radiological controls interface with ISM and site safety programs.

In promulgating 10 CFR 835, DOE considered alternatives to reduce the risk from radiation exposure to workers that included retaining the current occupational dose limits, reducing these limits, and emphasizing efforts to maintain occupational doses ALARA. After considering public comments on this issue, DOE elected to emphasize the ALARA process to maintain occupational dose for DOE and contractor employees as far below the current regulatory occupational dose limits as reasonably achievable. Adopting the ALARA process in DOE occupational radiation protection regulations also provides consistency with recommendations provided in the President's Radiation Protection

Guidance to Federal Agencies For Occupational Exposure, which endorsed the ALARA process.

The importance of the ALARA concept was further stressed in DOE P 441.1, *DOE Radiological Health and Safety Policy*, which states:

It is the policy of the Department of Energy to conduct its radiological operations in a manner that ensures the health and safety of all its employees, contractors, and the general public. In achieving this objective, the Department shall ensure that radiation exposures to its workers and the public and releases of radioactivity to the environment are maintained below regulatory limits and deliberate efforts are taken to further reduce exposures and releases ALARA. The Department is fully committed to implementing a radiological control program of the highest quality that consistently reflects this policy.

10 CFR 835 requires formal plans and measures for maintaining occupational exposures ALARA as part of the documented radiation protection program. Measures include incorporating ALARA considerations into the design of new facilities and modifications of existing facilities, as well as activities that pose the potential for significant occupational dose. Additionally, administrative controls are addressed as measures which supplement engineered controls and are integrated into the work planning process. Record keeping and training requirements related to ALARA are also specified.

Due to the complex nature of many DOE activities, a combination of radiological and non-radiological hazards may be encountered. Identification of non-radiological hazards is critical to the ALARA process, because efforts to apply the ALARA process may inadvertently increase risks from non-radiological hazards. An ISM approach that optimizes worker protection from all hazards should be considered in the ALARA process for a given DOE activity.

26. Occupational safety personnel must demonstrate working level knowledge of the application of basic and applied sciences to ISM.

- a. Discuss role of mathematical tools (e.g., algebra, trigonometry, calculus, statistics, and symbolic logic) in the safety field in analyzing quantities, magnitudes, and probabilities.**

The following is taken from DOE-HDBK-1014/1-92.

DOE-HDBK-1014/1-92, volume 1, *DOE Fundamentals Handbook: Mathematics*, was developed to assist nuclear facility operating contractors provide operators, maintenance personnel, and the technical staff with the necessary fundamentals training to ensure a basic understanding of mathematics and its application to facility operation. This handbook includes a review of introductory mathematics and the concepts and functional use of algebra, geometry, trigonometry, and calculus. Word problems, equations, calculations, and practical exercises that require the use of each of the mathematical concepts are also presented. This information will provide personnel with a foundation for understanding and performing basic mathematical calculations that are associated with various DOE nuclear facility operations.

The following is taken from DOE-HDBK-1014/2-92.

Statistics is a method or technique which will enable us to approach a problem of determining a course of action in a systematic manner in order to reach the desired results. Mathematically, statistics is the collection of great masses of numerical information that is summarized and then analyzed for the purpose of making decisions; that is, the use of past information is used to predict future actions.

b. Discuss physics laws associated with mechanics, heat, light, sound, electricity, magnetism, and radiation and application of these laws in the safety field.

The following is taken from DOE-HDBK-1010-92.

DOE-HDBK-1010-92, *DOE Fundamentals Handbook: Classical Physics*, was developed to assist nuclear facility operating contractors provide operators, maintenance personnel, and the technical staff with the necessary fundamentals training to ensure a basic understanding of physical forces and their properties. The handbook includes information on the units used to measure physical properties; vectors and how they are used to show the net effect of various forces; Newton's laws of motion and how to use these laws in force and motion applications; and the concepts of energy, work, and power and how to measure and calculate the energy involved in various applications. This information will provide personnel with a foundation for understanding the basic operation of various types of DOE nuclear facility systems and equipment.

The basis for modern mechanics was developed in the seventeenth century by Sir Isaac Newton. From his study of objects in motion, he formulated three fundamental laws. The first law of motion states "an object remains at rest (if originally at rest) or moves in a straight line with constant velocity if the net force on it is zero." Newton's second law states "the acceleration of a body is proportional to the net (i.e., sum or resultant) force acting on it and in the direction of the net force." This law establishes the relationship between force, mass, and acceleration and can be written mathematically. This law is used to define units and is one of the most important laws of physics. The third law of motion states "if a body exerts a force on a second body, the second body exerts an equal and opposite force on the first." This law is basic to the understanding of force. It states that forces always occur in pairs of equal and opposite forces.

c. Discuss basic chemistry concepts, including atomic structure, bonding, states of matter, chemical energy and equilibrium, and chemical kinetics. DOE-HDBK-1015/2-93, *DOE Chemistry Handbook*.

The following is taken from DOE-HDBK-1015/1-93.

DOE-HDBK-1015, *DOE Fundamentals Handbook: Chemistry*, volumes 1 and 2, was developed to assist nuclear facility operating contractors in providing operators, maintenance personnel, and the technical staff with the necessary fundamentals training to ensure a basic understanding of chemistry. DOE-HDBK-1015 includes information on the atomic structure of matter; chemical bonding; chemical equations, chemical interactions involved with corrosion processes; water chemistry control, including the principles of water treatment; the hazards of chemicals and gases, and basic gaseous diffusion processes. This information will provide personnel with a foundation for

understanding the chemical properties of materials and the way these properties can impose limitations on the operation of equipment and systems.

Atomic Structure

All matter is composed of atoms, existing individually or in combination with each other. An atom is an extremely small electrically-neutral particle. It is the smallest unit involved in the chemical change of matter. Atoms can be treated as distinct particles because they behave as such chemically, but atoms themselves are composed of even smaller subparts. Understanding these atomic subparticles is important in understanding chemistry. An atom is composed of a positively-charged nucleus orbited by one or more negatively-charged particles called electrons. The nucleus is the core of an atom. It has a positive charge because it usually consists of two particles, the neutron and the proton. The neutrons are electrically neutral, and the protons are electrically positive. A nucleus with one proton has a charge of +1 (or simply 1), and a nucleus with two protons has a +2 charge. Together the neutrons and protons give the nucleus its mass, but the proton alone gives the nucleus its positive charge. Neutrons and protons are relatively massive and are essentially equal in mass.

The particles that orbit the nucleus are electrons. They are very small, with a mass only 1/1835 the mass of a proton or neutron. Each electron is negatively charged, and the charge of one electron is equal in magnitude to the charge of one proton. The number of electrons orbiting a nucleus is exactly equal to the number of protons contained in that nucleus. The equal and opposite charges cancel each other, and the atom as a whole is neutral.

The electrons are bound in the atom by electrostatic attraction. The atom remains neutral unless some external force causes a change in the number of electrons. The diameter of the atom is determined by the range of the electrons in their travels around the nucleus and is approximately 10^{-8} cm. The diameter of the nucleus is roughly 10,000 times smaller, approximately 10^{-13} to 10^{-12} cm. Because the nucleus is composed of neutrons and protons that are about 1835 times heavier than an electron, the nucleus contains practically all the mass of the atom, but constitutes a very small fraction of the volume. Although electrons are individually very small, the space in which they orbit the nucleus constitutes the largest part of the atomic volume.

Bonding

Molecules are groups or clusters of atoms held together by means of chemical bonding. Regardless of the type of bond, specific amounts of one element will react with specific amounts of the element(s) with which it is combined.

States of Matter

The term “states of matter” refers to the physical forms in which matter exists: solid, liquid, and gas. Solids are characterized as having a definite shape and a definite volume. In a solid, the forces that keep the molecules or atoms together are strong. Therefore, a solid does not require outside support to maintain its shape.

Liquids have definite volumes but indefinite shapes and are slightly compressible. Liquids take the shape of their containers. The forces that keep a liquid’s molecules or atoms together are weaker than in the solids.

Gases are readily compressible and capable of infinite expansion. They have indefinite shape and indefinite volume. Of the three states of matter, gases have the weakest forces holding their molecules or atoms together. The different states of matter have one thing in common; they can all be broken down into fundamental units called atoms.

Chemical Energy and Equilibrium

Based on experimental data, it is known that chemical reactions involve only the electrons in atoms. In fact, only some of the electrons are involved. Because chemical properties are periodic, there must also be a periodic characteristic about electrons. This characteristic is the manner in which electrons are arranged in the atom. Electrons are in constant motion around the nucleus. They have both kinetic and potential energy, and their total energy is the sum of the two. The total energy is quantized; that is, there are definite, discrete values of total energy that atomic electrons can possess. These energy states can be visualized as spherical shells around the nucleus separated by forbidden areas where electrons cannot exist in a stable state. In general, electrons closer to the nucleus have a lower energy state. Atomic electrons always seek the lowest energy state available.

Equilibrium is the point at which the rates of the forward and reverse reactions are exactly equal for a chemical reaction if the conditions or reaction are constant.

Chemical Kinetics

Kinetics is the study of the factors which affect the rates of chemical reactions. There are five principal factors to consider: concentration, temperature, pressure, the nature of the reactions, and the catalyst.

d. Discuss biological sciences, including heredity, diversity, reproduction, development, structure, and function of cells, organisms, and populations, with emphasis on human biology.

The following is taken from National Aeronautics and Space Administration, Science Content Standards: 5-8, Guide to the Content Standard.

Living systems at all levels of organization demonstrate the complementary nature of structure and function. Important levels of organization for structure and function include cells, organs, tissues, organ systems, whole organisms, and ecosystems. All organisms are composed of cells—the fundamental unit of life. Most organisms are single cells; other organisms, including humans, are multicellular.

Cells carry on the many functions needed to sustain life. They grow and divide, thereby producing more cells. This requires that they take in nutrients, which they use to provide energy for the work that cells do and to make the materials that a cell or an organism needs.

Specialized cells perform specialized functions in multicellular organisms. Groups of specialized cells cooperate to form a tissue, such as a muscle. Different tissues are grouped together to form larger functional units, called organs. Each type of cell, tissue, and organ has a different structure and set of functions that serve the organism as a whole.

Reproduction is a characteristic of all living systems; because no individual organism lives forever, reproduction is essential to the continuation of every species. In many species, including humans, females produce eggs and males produce sperm. An egg and sperm unite to begin development of a new individual. That new individual receives genetic information from its mother (via the egg) and its father (via the sperm). Every organism requires a set of instructions for specifying its traits. Heredity is the passage of these instructions from one generation to another.

Hereditary information is contained in genes, located in the chromosomes of each cell. Each gene carries a single unit of information. An inherited trait of an individual can be determined by one or by many genes, and a single gene can influence more than one trait. A human cell contains many thousands of different genes. The characteristics of an organism can be described in terms of a combination of traits. Some traits are inherited and others result from interactions with the environment.

A population consists of all individuals of a species that occur together at a given place and time. All populations living together and the physical factors with which they interact compose an ecosystem. Populations of organisms can be categorized by the function they serve in an ecosystem. All animals, including humans, are consumers, which obtain food by eating other organisms.

The number of organisms an ecosystem can support depends on the resources available and abiotic factors, such as quantity of light and water, range of temperatures, and soil composition. Given adequate biotic and abiotic resources and no disease or predators, populations (including humans) increase at rapid rates. Lack of resources and other factors, such as predation and climate, limit the growth of populations in specific niches in the ecosystem.

Millions of species of animals, plants, and microorganisms are alive today. Although different species might look dissimilar, the unity among organisms becomes apparent from an analysis of internal structures, the similarity of their chemical processes, and the evidence of common ancestry. Biological evolution accounts for the diversity of species developed through gradual processes over many generations. Species acquire many of their unique characteristics through biological adaptation, which involves the selection of naturally occurring variations in populations. Biological adaptations include changes in structures, behaviors, or physiology that enhance survival and reproductive success in a particular environment. Extinction of a species occurs when the environment changes and the adaptive characteristics of a species are insufficient to allow its survival.

e. Discuss behavioral sciences, including individual differences, attitudes, learning, perception, and group behavior and application of these in the safety field.

Individual Differences

The following is taken from *Personality, Perception, and Attribution*, South-Western Educational Publishing, Chapter 3.

Individual differences refers to the way in which factors such as skills, abilities, personalities, perceptions, attitudes, values, and ethics differ from one individual to another. Managers face the challenge of working with people who possess a multitude of

individual characteristics, so the more managers understand individual differences, the better they can work with others.

Attitudes

The following is taken from Loyola University New Orleans, Chapter 10, Perception, Attitudes, Beliefs, and Values.

Attitudes develop primarily because they tie an individual to a group that the person feels can aid in attaining important goals. We tend to prefer what coincides with what we already believe.

Learning

The following is taken from dynamicflight.com, The Learning Process.

To learn is to acquire knowledge or skill. Learning also may involve a change in attitude or behavior. Learning theory may be described as a body of principles advocated by psychologists and educators to explain how people acquire skills, knowledge, and attitudes. Over the years, many theories have attempted to explain how people learn. Even though psychologists and educators are not in complete agreement, most do agree that learning may be explained by a combination of two basic approaches: behaviorism and the cognitive theories.

The ability to learn is one of the most outstanding human characteristics. Learning occurs continuously throughout a person's lifetime. To define learning, it is necessary to analyze what happens to the individual. An individual's way of perceiving, thinking, feeling, and doing may change as a result of a learning experience. Thus, learning can be defined as a change in behavior as a result of experience.

Perception

The following is taken from Loyola University New Orleans, Chapter 10, Perception, Attitudes, Beliefs, and Values.

As a behavioral process, perception begins with the assumption that people behave in a rational, purposeful, logical manner, depending on how they perceive the objective world. Perception involves intake or awareness through any of the senses. When considering the perception process we might conclude the following:

- People respond to things according to the physical realities in nature.
- The physical reality is perceived according to some possible distortions in subjective processes.
- People enter into a transaction with the energies of nature and abstract components that they integrate without perceptual processes to create the world in which they operate.

Group Behavior

The following is taken from Reference for Business, Encyclopedia of Business, 2nd edition, Organizational Behavior.

Organizational behavior is an academic discipline concerned with describing, understanding, predicting, and controlling human behavior in an organization

environment. Organizational behavior has evolved from early classical management theories into a complex school of thought—and it continues to change in response to the dynamic environment and proliferation of corporate cultures in which today's businesses operate.

Understanding one individual's behavior is a challenging problem in and of itself. A group, made up of different individuals and multiple relationships among those individuals, is even more complex. Ultimately, the work of organizations gets done through the behavior of people, individually or collectively; on their own or in collaboration with technology.

Organizational behavior scientists study four primary areas of behavioral science: individual behavior, group behavior, organizational structure, and organizational processes. They investigate many facets of these areas like personality and perception, attitudes and job satisfaction, group dynamics, politics and the role of leadership in the organization, the impact of stress on work, decision-making processes, the communications chain, and company culture and climates. In regard to individuals and groups, researchers try to determine why people behave the way they do.

f. Discuss general engineering and technology disciplines, including applied mechanics, properties of materials, electrical circuits and machines, principles of engineering design and drawings, and computer science.

Applied Mechanics

The following is taken from DOE-HDBK-1018/1-93.

DOE-HDBK-1018/1-93, *DOE Fundamentals Handbook, Mechanical Science*, volumes 1 and 2, were developed to assist nuclear facility operating contractors in providing operators, maintenance personnel, and the technical staff with the necessary fundamentals training to ensure a basic understanding of mechanical components and mechanical science. DOE-HDBK-1018/1-93 includes information on diesel engines, heat exchangers, pumps, valves, and miscellaneous mechanical components. This information will provide personnel with a foundation for understanding the construction and operation of mechanical components that are associated with various DOE nuclear operations and maintenance. For more information review volumes 1 and 2.

Properties of Materials

The following is taken from DOE-HDBK-1017/1-93.

DOE-HDBK-1017/1-93, *DOE Fundamentals Handbook, Material Science*, volumes 1 and 2, were developed to assist facility operating contractors in providing operators, maintenance personnel, and the technical staff with the necessary fundamentals training to ensure a basic understanding of the structure and properties of metals. DOE-HDBK-1018/1-03 includes information on the structure and properties of metals, stress mechanisms in metals, failure modes, and the characteristics of metals that are commonly used in DOE nuclear facilities. This information will provide personnel with a foundation for understanding the properties of facility materials and the way these properties can impose limitations on the operation of equipment and systems. For more information review volumes 1 and 2.

Electrical Circuits and Machines

The following is taken from DOE-HDBK-1011/1-92.

DOE-HDBK-1011/1-92, *DOE Fundamentals Handbook, Electrical Science*, volumes 1 through 4, were developed to assist nuclear facility operating contractors provide operators, maintenance personnel, and the technical staff with the necessary fundamentals training to ensure a basic understanding of electrical theory, terminology, and application. DOE-HDBK-1011/1-92 includes information on AC and DC theory, circuits, motors, and generators; AC power and reactive components; batteries; AC and DC voltage regulators; transformers; and electrical test instruments and measuring devices. This information will provide personnel with a foundation for understanding the basic operation of various types of DOE nuclear facility electrical equipment. For more information review volumes 1 through 4.

Principles of Engineering Design and Drawings

The following is taken from DOE-HDBK-1016/2-93.

DOE-HDBK-1016/2-93, *DOE Fundamentals Handbook, Engineering Symbolology, Prints, and Drawings*, volumes 1 and 2, were developed to assist nuclear facility operating contractors in providing operators, maintenance personnel, and technical staff with the necessary fundamentals training to ensure a basic understanding of engineering prints, their use, and their function. DOE-HDBK-1016/2-93 includes information on engineering fluid drawings and prints; piping and instrument drawings; major symbols and conventions; electronic diagrams and schematics; logic circuits and diagrams; and fabrication, construction, and architectural drawings. This information will provide personnel with a foundation for reading, interpreting, and using the engineering prints and drawings that are associated with various DOE nuclear facility operations and maintenance. For more information review volumes 1 and 2.

Computer Science

The following is taken from the Office of Personnel Management, Qualification Standards for General Schedule Positions, Computer Science Series, 1550, Associated Group Standard.

This series includes professional positions which primarily involve the application of, or research into, computer science methods and techniques to store, manipulate, transform or present information by means of computer systems. The primary requirements of the work are: professional competence in applying the theoretical foundations of computer science, including computer system architecture and system software organization, the representation and transformation of information structures, and the theoretical models for such representations and transformations; specialized knowledge of the design characteristics, limitations, and potential applications of systems having the ability to transform information, and of broad areas of applications of computing which have common structures, processes, and techniques; and knowledge of relevant mathematical and statistical sciences.

27. Occupational safety personnel must demonstrate a familiarity level knowledge of safety in the research and development, manufacture, use, transportation, testing, demilitarization, storage and disposal of explosives in DOE M 440.1-1A, DOE Explosive Safety Manual.

a. Describe role of hazard analysis and planning techniques for designing or evaluating explosives operations and storage.

The following is taken from DOE M 440.1-1A.

Hazard analysis is used in conjunction with DOE M 440.1-1A for developing storage areas. The hazard analysis identifies the hazards and helps identify areas that may be located nearby to apply the formula for establishing the safe separation distance. The amount of required storage will be compared to the hazard analysis to determine if the storage facility is adequate for that amount of material.

Before starting any operation involving explosives, a hazard analysis shall be undertaken to identify any abnormal problems that will require special training, equipment, or procedures to safeguard personnel conducting the operation.

Before beginning any explosives synthesis, formulation, manufacturing, testing, or disposal operation, a PrHA shall be performed. A single PrHA may be performed for similar processes performed in a single facility, provided that the “worst-case” process is the basis for the hazard analysis. If required, a shield or other protective measure shall be employed. Selection criteria for the worst-case process are

- sensitivity of materials
- quantity of materials
- number of personnel potentially affected
- impact on other operations/activities

The PrHA shall be formally documented. Employees and employee representatives shall be consulted on the PrHA. The result of the PrHA shall be provided to employees involved in or affected by the operation. The PrHA shall be updated and revalidated at least every five years. The facility manager shall be responsible for establishing a system to address the team’s findings and recommendations promptly. Corrective actions, schedules for corrective actions, and completion of corrective actions shall be formally documented. Such documentation shall be filed with the PrHA. Files containing PrHAs, updates, and corrective actions status shall be maintained for the life of the process.

b. Discuss the importance of development, implementation, and maintenance of safe work procedures for explosives operations and storage such as site plans.

The following is taken from DOE M 440.1-1A.

DOE M 440.1-1A, chapter VII, Operating Procedures, establishes requirements for preparing and controlling procedures used for operations involving explosives at DOE installations. These requirements minimize the probability of an incident resulting from operations using outdated, inapplicable, or incomplete procedures, or from operations performed in violation of established practices.

Chapter VII also specifies that procedures must be generated for all explosives operations because the step-by-step reasoning process that is used in developing the procedure will identify many safety-related problem areas that might be overlooked otherwise. In addition, the approval system for new or revised procedures also provides other viewpoints and knowledge that may not be available to the originator and may need incorporation into the procedures.

Each facility shall establish a program to review the explosive materials stored at that facility. Explosives may degrade during prolonged storage, increasing the hazards of handling or use. Explosives containers shall be designed and constructed so they will not leak and will protect their contents from excessive movement, external stimuli, contamination, or spillage during handling, transportation, and storage. Container closures shall prevent spilling or leakage of contents if the container is overturned. For more in-depth discussion and charts concerning storage methods and types see DOE M 440.1-1A, section 17.0, Explosives Storage.

c. Explain the explosives chain addressing explosives type and quantity, environmental conditions, initiation devices, and general physics of an explosion.

The following is taken from DOE M 440.1-1A.

Each type of explosive and initiating device is assigned to an appropriate storage compatibility group (A through G, L, and S) for the purpose of storage at DOE facilities. The groups are defined in the following paragraphs.

- Group A—Initiating explosives. Bulk initiating explosives that have the necessary sensitivity to friction, heat, or shock to make them suitable for use as initiating elements in an explosives train. Examples are lead azide, lead styphnate, mercury fulminate, and tetracene.
- Group B—Detonators and similar initiating devices not containing two or more independent safety features. Items containing initiating explosives that are designed to initiate or continue the functioning of an explosives train. Examples are detonators, blasting caps, small arms primers, and fuses.
- Group C—Bulk propellants, propellant charges, and devices containing propellant with or without their own means of initiation. Items that will deflagrate, explode, or detonate upon initiation. Examples are single-, double-, triple-base, and composite propellants, rocket motors (solid propellant), and ammunition with inert projectiles.
- Group D—High explosives (HEs) and devices containing explosives without their own means of initiation and without a propelling charge, or articles containing a primary explosives substance and containing two or more effective protective features. This group shall include explosives and ammunition that can be expected to explode or detonate when any given item or component thereof is initiated.
- Group E—Explosives devices without their own means of initiation and with propelling charge. Examples are artillery ammunition and rockets.
- Group F—Explosives devices with their own means of initiation and with or without propelling charge.
- Group G—Pyrotechnic materials and devices containing pyrotechnic materials. Examples are devices that when functioning, result in an incendiary, illumination, lachrymatory, smoke, or sound effect.

- Group H—Ammunition containing explosives and white phosphorus or other pyrophoric material. Ammunition in this group contain fillers, which are spontaneously flammable when exposed to the atmosphere. Examples are white phosphorus, plasticized white phosphorus, or other ammunition containing pyrophoric material.
- Group J—Ammunition containing explosives and flammable liquids or gels. Ammunition in this group contain flammable liquids or gels other than those that are spontaneously flammable when exposed to water or the atmosphere. Examples are liquid or gel-filled incendiary ammunition, fuel-air explosive devices, flammable liquid fueled missiles, and torpedoes.
- Group K—Ammunition containing explosives and toxic chemical agents. Ammunition in this group contain chemicals specifically designed for incapacitating effects more severe than lachrymation. Examples are artillery or mortar ammunition (fused or unfused), grenades, and rockets or bombs filled with a lethal or incapacitating chemical agent.
- Group L—Explosives or ammunition not included in other compatibility groups which present a special risk, requiring isolation of each type. This group shall include explosives or ammunition having characteristics that do not permit storage with other similar or dissimilar materials. Examples are damaged explosives, suspect explosives, and explosives, explosive devices or containers that have undergone severe testing unless documented determination is made that these items do not present a special risk; fuel/air explosive devices, and water-activated devices. Also included are experimental explosives, explosives of temporary interest, newly synthesized compounds, new mixtures and salvaged explosives until they have been established to be compatible with the original materials. Types presenting similar hazards may be stored together.
- Group N—Hazard division 1.6 ammunition containing only extremely insensitive detonating substances.
- Group S—Explosives, explosive devices, or ammunition presenting no significant hazard. Explosives or ammunition so designed or packed that when in storage any hazardous effects from accidental functioning are limited to the extent that they do not significantly hinder firefighting. Examples include: explosive switches or valves and small arms ammunition.

General Physics of an Explosion

The following is taken from Physics for Future Presidents, Chapter 1, Energy, Power, and Explosions, by Richard A. Muller.

The following paragraphs use trinitrotoluene (TNT) as an explosion to describe the general physics of an explosion. At normal room temperature, 20°C, the absolute temperature is $T = 20 + 273 = 293$. So using the formula for temperature, the internal random energy per mole is $E = T/335 = 300/333 \approx 1$ Cal per mole. The formula for TNT is $C_7H_5N_3O_6$. Adding up the gram molecular weight:

7 carbons	84
5 hydrogens	5
3 nitrogens	42
6 oxygens	96
TOTAL	247

So the internal energy of 247 grams of TNT is 1 Cal, at room temperature. For one gram, it is $1/247$ Cal. When TNT explodes, it suddenly releases 1 Cal per gram. That is 247 times as big as its previous amount. The internal kinetic energy suddenly increases by a factor of 247. If the molecules didn't break apart (they do—and that complicates it a little), the temperature would suddenly become 247 times greater. That would make the temperature $247 \times 293 = 72,000$ K. (Temperature measured in absolute scale is designated by K, rather than by C.)

Nothing is a solid at 72,000 C. The forces between the molecules are not strong enough to hold them together. The gram of TNT is suddenly converted into a very very hot gas.

What will that hot gas do? Even at normal room temperatures, gases are typically 1000 times less dense than a solid. So just the fact that it turns into a gas makes it expand by a factor of 1000. But the fact that it is hot makes it expand even more. According to the ideal gas law, the volume is proportional to the absolute temperature (atmospheric pressure is constant). So the volume increases by a factor of 247 (the same factor for the temperature). The increase in volume on top of the factor of 1000 provides a total expansion in volume of 247,000.

That is what an explosion really is. A solid suddenly turns into a very hot gas, and the hot gas suddenly expands. The velocity of expansion is very high, since the atoms have all been given a very high velocity. The volume goes up, in this case, by 247,000.

Optional calculation: increase in linear size. When an object increases in volume by 247,000, how much does its size change? To work this out, and to make it easy, assume that the shape is that of a cube. Assume that the explosive has an initial volume of 1 cubic centimeter ($= 1 \text{ cm}^3$), and that in the explosion its volume increases to $247,000 \text{ cm}^3$. What is the new side of the cube? The answer can be found by pushing the cube-root button on a calculator: 62.7 cm. Check this answer from the fact that $62.7 \times 62.7 \times 62.7 = 157,000$. This means that all the material in that one gram piece of TNT suddenly spreads out over a distance 62.7 times wider than the original piece.

The expanding gas pushes everything out of the way. Any material nearby picks up the velocity of the gas, and as that material is thrown out, it often does more damage than the hot expanding gas. Terrorists typically surround the explosive with a pipe, or pieces of metal. When the metal fragments fly out at high speed, they are what do the most harm.

d. Discuss major principles of personnel protection from explosive hazards and the application of each principle to explosives operations.

The following is taken from DOE M 440.1-1A.

Each bay that houses an explosives activity shall have a protection level based on the hazard class determined for the activity. The level of protection may be provided by equipment design, structural design, operation separation, or provision of operational shields. The levels of protection required for each hazard class are as follows and shall be required for new facilities or redesign of any existing facilities when changes in activities will result in a more hazardous class.

Explosives Bay

Class IV. Bays for class IV (negligible probability of accidental initiation) activities shall provide protection from fire hazards effects. This protection may be achieved by hazard class/division 1.3 aboveground-magazine distance separation or by a design that contains the effects of an accident. Because accidental detonation is not considered credible, class IV bays shall be sited and designed as acceptors rather than donors for the effects of blast overpressure, structural collapse, and missiles (hazardous fragments).

Class III. Bays for class III (low accident potential) activities shall provide protection from explosion propagation from bay to bay within buildings and between buildings that are located at intraline or magazine distance. If intermediate storage of explosives is within an operating building containing class II or class I operations, the intermediate storage or staging bay will require class II level of protection. Examples of class II activities include weighing, assembly and disassembly, some wet machining, some environmental testing, and some packaging operations. Minimum separation distances may be reduced when explosives bays are designed to adequately contain the effects of an accident (blast pressures and missiles).

Class II. Bays for class II (moderate accident potential) activities shall comply with the requirements for class III bays, and in addition provide protection to prevent fatalities and severe personnel injuries in all occupied areas other than the bay of occurrence.

Prevention of fatalities and severe injuries is satisfied when personnel in occupied areas other than the bay of occurrence will not be exposed to the following:

- Overpressures greater than 100 kPa (15 psi) maximal effective pressure.
- Structural collapse resulting from overpressure or debris impact. Structural collapse is a structural component's failure as a direct result of a facility losing structural integrity. This collapse must not result in explosives propagation, fatalities, or severe personal injuries.
- Missiles (hazardous fragments) generated in acceptor-occupied areas. Hazardous fragments that can cause fatalities and severe injuries are defined as those having greater than 58 ft-lb impact energy. The threshold pressure for eardrum rupture is 34 kPa (5 psi); one-half of the threshold pressure for lung damage is 100 kPa (15 psi).

Class I. Bays for class I (high accident potential) activities shall comply with the requirements for class II bays, and in addition provide protection to prevent serious personal injuries, including personnel performing the activity, personnel in other occupied areas, and transients. This protection can be achieved by controlling blast and debris through suppression, containment, or establishing an exclusion area with positive access control. Serious injury prevention is satisfied when personnel will not be exposed to

- overpressures greater than 34 kPa (5 psi) maximal effective pressure, which should not exceed 16 kPa (2.3 psi) peak positive incident pressure.
- structural collapse of a facility or building from overpressure or debris impact. Structural collapse a structural component's failure as a direct result of loss of structural integrity.
- missiles (hazardous fragments)—hazardous fragments that can cause serious injuries are defined as those having greater than 11 ft-lb impact energy.
- thermal fluxes greater than 0.3 cal/cm²/sec.

e. Describe types, purpose, and application of personal protective clothing and equipment for explosives operations.

The following is taken from DOE M 440.1-1A.

Clothing

Each operation shall be analyzed to determine when personnel working with explosives and toxic materials must wear approved coveralls or laboratory coats to prevent contact with these materials and prevent contaminating personal apparel. Flame-retardant coveralls may be desired for explosives operations with the potential for flash fire. These coveralls shall not have cuffs and should not have metallic fasteners. Written procedures shall include protective clothing and equipment requirements. Cotton or other antistatic outer and undergarments, including socks, should be worn where generation of static electricity would create a hazard.

Footwear

Personnel working in areas where electrostatic-sensitive explosive powders or materials are handled shall wear conductive, non-sparking footwear. Exception: personnel working on electrical or electronic equipment shall not wear conductive footwear unless protected by insulated mats, GFCIs, etc. Personnel working in other areas where explosives contamination may be present shall wear non-sparking footwear or bootie shoe coverings.

Respirators

Approved respiratory protection shall be worn when exhaust ventilation is unavailable or does not adequately control airborne particulate, gases, or vapors released during explosives operations. The employee shall have current approval to wear respiratory protection.

Eye Protection

Personnel working in or visiting eye hazard areas shall wear suitable eye protection devices, particularly when electro-explosive devices (EEDs) are handled. Explosive operations shall be evaluated for eye hazard risks. Contact lenses shall not be considered appropriate eye protection.

Gloves

Skin contact with some explosives and associated materials can result in dermatitis or absorption across the skin barrier. Operations where these materials are present must be evaluated for skin contact hazards and the need for the proper gloves.

f. Describe general considerations for the storage and use of different classes of explosives and blasting agents, including the construction, capacity, and placement of facilities or operations.

The following is taken from DOE M 440.1-1A.

Storage Magazine Facilities

Permanent explosives facilities shall comply fully with U.S. (DoD), UFC 3-340-02, *Structures to Resist the Effects of Accidental Explosions*, and DOE/TIC-11268, *A Manual for the Prediction of Blast and Fragment Loading of Structures*. Portable magazines should be ventilated and resistant to water, fire, and, theft. They can be made of any

material that meets these guidelines. Portable magazines shall be sited per the DoD 6055.9-STD, *Ammunition and Explosives Safety Standard* as above ground magazines.

Placards shall be posted on or near each magazine door, specifying explosive and personnel limits and general safety precautions that should be observed during work in the magazine.

Vegetation around storage magazines should be controlled to minimize potential damage to the magazine.

At least two fire extinguishers, minimum rating 2A:10BC and winterized where necessary, should be provided and maintained for immediate use by personnel working around a magazine. These extinguishers may be located in the area or available on an explosives transportation vehicle. The purpose of these extinguishers is to fight small external fires or magazine fires that do not involve explosives.

Suitably rated telephone or other emergency communication equipment should be provided in magazine storage areas. All communication equipment located outdoors should be protected from the weather.

Temperature Control

In general, storage magazines should not be heated unless heating is necessary to prevent damage caused by sudden temperature changes or when dimensional changes of components are undesirable.

Magazines requiring heat should be heated with steam, hot water, or electrically heated hot water. Some magazines with tight temperature controls may require both heating and air conditioning. Electrical systems with forced air through ducts may be allowed if the systems are located exterior to any explosive hazard.

Heating coils shall be arranged so that explosives material cannot come into contact with the coils. They shall be equipped with covers designed to prevent storage of materials on top of the coils.

Maximum and minimum temperature monitors should be provided in all heated magazines.

Storage Magazine Operations

Explosives items shall be properly packaged and stored in either DOT-approved manufacturers' containers/packages or in specified onsite containers.

Explosives may be stored on magazine shelves. The bottom of the container should not be more than 2 m off the floor.

Explosives and explosives containers in storage shall be positioned safely and securely. If explosives containers must be stacked, they shall be placed in stable arrays.

Load limits shall be established for shelving in magazines containing explosives. If overloading is possible, the loading conditions shall be posted.

Materials shall not be left suspended by booms, cranes, or hoists in any explosives storage facility.

Stored explosives should be segregated by lot designation. Stacks of explosives should be arranged so that air freely circulates to all parts of the stack. To prevent moisture accumulation, pallets or appropriate dunnage should be used to ensure that containers are not stacked directly on the magazine floor.

Aisles shall be wide enough to accommodate inspection, inventory, sampling, and materials handling operations of the stored explosives containers.

Crews shall not be permitted to work in a position that requires passing the work aisle or the position of a second crew to reach the exit. Unobstructed aisles shall be maintained to permit rapid exit of personnel.

Each crew working in a magazine must have their own exit route that does not interfere with exit routes for other crews.

Magazines shall be locked at all times except when permissible operations are in progress or opened for ventilation. Personnel shall be present while the magazine is open for ventilation. All exit doors shall be unlocked and open when personnel are working in the magazine.

Each magazine shall be inventoried at least annually to determine the total weight of explosives present (to ensure this weight conforms to allowable quantity-distance (Q-D) constraints) and to remove and destroy materials that are not properly identified or labeled.

The liquid level in storage containers for wet explosives shall be checked and replenished as necessary at least once a year. A log of the checks shall be maintained.

Empty containers, tools, conveyors, lift trucks, skids, etc., should not be stored in a magazine containing explosives.

Combustible materials such as excess dunnage, packing material, and boxes shall not be stored in a magazine containing explosives.

Flammable liquids shall not be stored or used in explosives magazines unless the liquid is an explosive, is needed as an explosives-wetting agent, or is an integral part of an explosives device.

Operations in and around magazines shall be prohibited when an electrical storm is in progress and minimized when it is evident that such a storm is approaching.

Explosives-handling operations shall not be performed when magazine entranceways are icy or do not provide adequate footing for any other reason.

Unless excepted, no operation in which hazardous materials are involved shall be permitted in any magazine. The following exceptions are recognized:

- Those operations incident to storage or removal from storage.

- Inspection and surveillance sampling of compatibility group D materials, and group C materials consisting of bulk propellants and insensitive HEs, provided that each storage container sampled is in good condition. Only one container of explosives shall be opened at one time in a magazine.
- Adding liquid to adjust the liquid composition level in which a group D explosive is stored. If only water is added to the explosive, the water should be distilled or deionized. Bacteria present in untreated water may produce gas during storage.

Construction

The following is taken from DOE M 440.1-1A.

The design of new facilities, or those with major modifications, shall conform to the DOE explosives safety requirements. Protective construction design features are specified in UFC 3-340-02 and DOE/TIC-11268.

Site and general construction plans for ammunition and explosives facilities as well as plans for changes in utilization of facilities or mission changes that adversely affect the explosives Q-D requirements shall be submitted to the site office for review and approval.

g. Discuss and demonstrate ability to apply quantity-distance criteria to explosives operations.

This is a performance-based KSA. The Qualifying Official will evaluate its completion. The following information from DOE M 440.1-1A may be helpful.

Chapter VI of DOE M 440.1-1A establishes Q-D and level-of-protection criteria for all DOE operations involving explosives. These criteria provide specific levels of personnel and property protection from the effects of potential fires and explosions within and outside of DOE installations.

The cardinal principle to be observed at any location or in any operation involving explosives, ammunition, severe fire hazards, or toxic materials is to limit, in a manner consistent with safe and efficient operation, the exposure to a minimum number of personnel, for a minimum time, and to a minimum amount of the hazardous material.

The facility management shall ensure that ammunition and explosives safety site plans are submitted to DOE for review and approval. DOE review and approval will be conducted by the AHJ for explosives safety within the site office.

A site plan must be developed and submitted for review by DOE/NNSA local authority. The site plan shall contain the following information:

- A Q-D chart containing the following:
 - Each sited facility listing maximum net explosives weight for each applicable hazard division
 - Actual and required distance to exposed sites
 - Q-D criteria used for siting each potential explosion site (PES)—exposed site relationship
- Map showing each PES, its clear zone, and all exposed sites within the clear zone
- Personnel limits for the explosives facility

- Brief description of explosives and non-explosives operations within the clear zone
- Statement that the current operation presents no significantly greater risk than that assumed when the facility was originally constructed
- If the facility does not meet current criteria for the operation being conducted, provide a statement
 - why it is not feasible to bring the facility up to current standards
 - that the current operation presents no significantly greater risk than that assumed when the facility was originally constructed

A letter of transmittal shall accompany each site plan or group of site plans. The letter should contain the reason for submittal and a request for site plan approval. For a grandfathered facility, note whether the facility meets current criteria for the operation being conducted.

If the siting has any unique characteristics explain what they are and what criteria is being applied.

h. Discuss hazards associated with uncontrolled electrical sources (e.g., static electricity and lightning) and application of required controls such as the following:

- **Lightning protection**
- **Nonsparking tools**
- **Conductive footwear and floors**
- **Equipment bonding and grounding**

Lightning Protection

The following is taken from DOEM 440.1-1A.

Lightning protection system (LPS) design consists of the use of strike termination means, low impedance paths to ground, and earth electrode systems, coupled with bonding of all conductive penetrations into the protected area, surge suppression, and side-flash protection. Metallic elements of the structure meeting the material requirements of NFPA 780, *Standard for Lightning Protection*, are allowed to serve as strike termination devices, down conductors, or parts of the earth electrode system. Facility management, the AHJ, and a person competent in LPS theory and design shall approve design variations from those specified below.

Design of LPSs per NFPA 780 shall be based on a 100-ft striking distance. The zone of protection provided by an LPS is the space beneath the LPS that is substantially immune to direct lightning attachment. The LPS design shall ensure that explosives facilities and their associated components that require lightning protection are within the LPS zone of protection. Structural elements of the building meeting the material requirements of NFPA 780 are authorized to serve as the LPS or parts of the LPS.

Design parameters for a Faraday cage and Faraday shield-like LPS shall be based, as a minimum, on a one percent threat level and include the following:

- Return stroke amplitude = 200 kA
- Rise rate = 400 kA/μsec
- Number of strokes per flash = 26 max

- Striking Distance = 100 ft
- Burn through of 0.19 in. for steel, 0.20 in. for copper, and 0.28 in. for aluminum
- Action = 3×10^6 amps²-sec.

The approved types of LPS are mast, catenary, integral air terminal, and Faraday cage or Faraday-like shield systems. Faraday cage or Faraday-like shield systems are preferred for new structures where applicable. The main features of each type system are summarized below.

Mast System

A mast system consists of one or more poles with a strike termination device connected to an earth electrode system by down conductors. The principal design parameters include the following:

- The minimum mast separation distance from the structure is 6 ft or the formula as defined in NFPA 780, $D = h/6$, whichever is greater where the h is the height of the mast of structure considered.
- Non-metallic masts require a metal air terminal or metal cap installed at the top that is connected to the earth electrode system by at least two down conductors installed on opposite sides of the mast.
- Metallic masts serve as both air terminal and down conductors, and will be connected to the earth electrode system with two independent main size conductors attached approximately symmetrically to the mast base.

Catenary System

The catenary LPS consists of wires stretched between the tops of two or more masts. The main design parameters include the following:

- Each wire shall be an electrically continuous run of main size conductor bonded to all down conductors.
- Non-metallic masts require a metal air terminal or metal cap installed at the top that is connected to the earth electrode system by at least two down conductors installed on opposite sides of the mast.
- Metallic masts serve as both air terminal and down conductors themselves, and shall be connected to the earth electrode system by two main size conductors attached approximately symmetrically to the mast base.
- The minimum vertical separation between an overhead wire and the protected structure, including its projections, shall be the greater of 6 ft or as defined in NFPA 780, as $D = (L/6n)$

where

D = Sideflash distance from a catenary

L = Length of lightning protection conductor between its grounded point and the point being calculated

n = 1.00 where there is a single overhead ground wire that exceeds 200 ft in horizontal length

n = 1.50 where there is a single overhead wire or more than one wire interconnected above the structure to be protected, such that only two down conductors are located greater than 20 ft and less than 100 ft apart

$n = 2.25$ where there are more than two dozen conductors spaced more than 25 ft apart within a 100-ft wide area that are interconnected above the structure being protected.

- Deflections of the wire resulting from wind, ice, or other weather conditions shall be considered in determining the separation distance. The supporting mast will be at least 6 ft from the structure.

Integral Air Terminal System

An integral LPS is one that has the strike termination devices mounted on the structure to be protected. These strike termination devices are connected to the earth electrode system via down conductors. Metallic structural members can serve as parts of the LPS.

However, side-flash protection is required. The relevant design parameters are:

- The down conductors of integral systems shall be installed in as nearly a vertical position as possible.
- No bend of a conductor shall form an included angle of less than 90 degrees, nor shall it have a radius of bend less than 8 in.
- The number of conductors and configuration of the connections between air terminals are as required by NFPA 780.
- Air terminals height and location are as required by NFPA 780.

Faraday Cage and Faraday-like Shield

The preferred method of protecting explosives operations from lightning flashes, as well as from other external sources of electromagnetic radiation, is to enclose the operations or facility inside a Faraday cage. A Faraday cage is an enclosure composed of a continuous grid of conductors, such that the voltage between any two points inside the enclosure is zero, when immersed in an electrostatic field. A Faraday cage or Faraday-like shield LPS is one where the protected volume is enclosed by a heavy metal screen or continuous metallic structure with all metallic penetrations bonded. The lightning current flows on the exterior of the structure not through the interior. A Faraday-like shield is formed by a continuous conductive matrix that is properly bonded and grounded.

Nonsparking Tools

The following is taken from DOE M 440.1-1A.

All firing pad and shot stand setup work that requires power tools or other potential spark-producing devices should be completed before work begins. The firing pad shall be cleared of all unnecessary gear. Special precautions and procedures will be developed and implemented if power tools or other spark-producing devices are needed after explosives are delivered to the firing pad.

Conductive Footwear and Floors

The following is taken from DOE M 440.1-1A.

Conductive floors and shoes should be used for grounding personnel in operations involving explosives that are sensitive to initiation by the electrostatic spark discharge from a person. Static discharge from a person may ignite many flammable liquids and air mixtures. In areas where personnel come into the proximity of static-sensitive explosives or vapors, conductive floors shall be installed except where adequate housekeeping, dust collection, ventilation, or solvent recovery methods eliminate the hazards of dust-air or

flammable vapor-air mixtures. Conductive floors may also be required in areas where operations involve EEDs that contain a static-sensitive explosive.

Conductive floors are not required throughout an entire building or room if the hazard is localized. In such cases, conductive mats or runners may be used where required. These mats or runners shall meet all specifications and test requirements that apply to conductive floors. Conductive wristbands may be substituted for conductive mats and footwear at fixed, grounded or bonded workstations or outdoor locations.

Equipment Bonding and Grounding

The following is taken from DOE M 440.1-1A.

Bonding straps can be used to bridge locations where electrical continuity may be broken by the presence of oil on bearings, paint, or rust at any contact point. Pressure contact alone is not adequate grounding for permanent equipment in contact with conductive floors or tabletops. Static grounds shall not be made to gas, steam, or air lines; dry pipe sprinkler systems; or air terminals of LPSs. Static grounds can be made to water pipes, ground cones, buried copper plates, or driven ground rods of an LPS. If a structure is equipped with an LPS, all grounds shall be interconnected. Wires used as static ground conductors should be at least No. 10 AWG or equivalent.

Testing Bonded Equipment Grounds

Grounding systems shall be tested for electrical resistance and continuity after installation has been completed and, in the case of active equipment, at intervals to be locally determined. If the equipment has been inactive for more than one month, the ground system shall be visually inspected for continuity before reactivation of the system. All exposed explosives or hazardous materials shall be removed before testing. When testing for resistance-to-ground, equipment should be considered as a unit except in the case of an electrically isolated device or a belt-driven machine. In measuring the total resistance-to-ground for belt-driven machinery, resistance of the belting is to be excluded.

Hazardous locations (operations where a static spark discharge may be dangerous). All conductive parts of equipment shall be bonded; in the case of grounded equipment, bonding shall be such that resistance to ground does not exceed 25 ohms, unless resistance is not to exceed 10 ohms because of a lightning protection installation. For existing equipment, the rate of static generation should be considered before making changes in grounding systems. The resistance of conductive rubber hose should not exceed 250,000 ohms.

i. Describe fire protection considerations for explosives operations.

The following is taken from DOE M 440.11-A.

The following fire protection criteria shall be required for all new facilities or redesign of existing facilities where changes in activities will result in a higher hazardous classification.

- Automatic fire suppression systems shall be installed in all buildings containing HEs and plutonium, except storage magazines.
- For buildings containing explosives, but no plutonium, facility management shall determine the need for fire suppression systems based on maximum fire loss

criteria and program mission interruptions and delays as outlined in the current versions of DOE O 420.1B; and DOE O 440.1B.

- Where fire suppression is required, each explosives bay shall have an individual feed with its controls protected outside the bay and located to enable system operation if a detonation occurs in any bay.
- Transmitted fire alarms shall distinguish between explosives and non-explosives areas through the use of annunciator panels at safe locations; small non-HE areas do not need separately transmitted alarms.

28. Occupational safety personnel must demonstrate a familiarity level knowledge of firearms safety and safeguards and security.

a. Describe how ISM applies to Safeguards and Security.

The following is taken from DOE G 450.4-1B.

The Department's Office of Oversight within the Office of Environment, Safety and Health, is solely responsible for DOE's internal independent ES&H oversight function. The Office of Independent Oversight and Performance Assurance is solely responsible for DOE's internal independent security and emergency management oversight function. These offices provide information and analysis needed to ensure that the Secretary, Department, contractor managers, and the public have an accurate, comprehensive understanding of the effectiveness, vulnerabilities, and trends of DOE's environment, safety, health, security, and emergency management policies and programs.

b. Identify PPE necessary during firearms use and explain how the PPE protects against the hazards.

The following is taken from DOE M 470.4-3A.

A risk assessment must determine the type of PPE required for the specific performance test (PT)/training activity being conducted.

The following PPE must be used when conducting training/PTs involving the use of dye-marking cartridge/paint ball during force-on-force and one-on-one engagements:

- Eye protection
- Full face and head protection, which includes covered protection for the ears
- Hand protection (gloves)
- Groin protection
- Throat protection
- Hearing protection (optional—unless diversionary devices are being used or exercise is conducted in an environment that requires noise protection). Sound levels generated by DMC/PB use are below OSHA requirements that require hearing protection.

When conducting training/PTs involving the use of airsoft systems with BBs, the minimum PPE is the JT Spectra face shield or equivalent.

c. Discuss firing range safety considerations, including required procedures and controls.

The following is taken from DOE M 470.4-3A.

Specific range safety rules include the following:

- It is mandatory to use approved eye and ear protection and other PPE as required by the range safety officer.
- Unsafe conditions must be reported immediately to an instructor.
- A firearm may only be exchanged with another shooter under the direct supervision of an instructor.
- Firearms must not be left unattended or unsecured.
- Firearm loading and firing may commence only on command.
- Shooters are not permitted to talk during a firing activity except in reply to an instructor as a part of the activity or to shout “cease fire” in an unsafe situation.
- Until the firing line has been declared safe by the firearms instructor, shooters must not move past or bend over on the line.
- All shooters must be trained on what constitutes an unsafe condition and to shout “cease fire” when such a condition is observed.
- Smoking, eating, or drinking must be prohibited while shooting.
- Alcoholic beverages and drugs are prohibited on firing ranges. Shooters taking medication must report this fact to the firearms instructor before reporting to the firing line. The firearms instructor is responsible for determining whether a shooter is fit based on the medication taken and whether it is safe for the shooter to use the range. A physician may be consulted if necessary.
- Shooters must take precautions to prevent hot spent cartridge and gunshot residues from getting inside their clothing.
- When a training session is completed, each firearm must be physically examined by the shooter and by a designated range safety officer or qualified firearms instructor to ensure that it is unloaded and in safe condition before leaving the range. If the shooter is using a duty firearm on the range, he or she may reload that weapon at the range if returning directly to duty.
- Shooters must collect unexpended ammunition and return it to a firearms instructor.
- While a firearm is being cleaned, live ammunition must not be allowed in the cleaning area.

d. Discuss principles of firearms safety and describe appropriate and mandated controls including why the armory should have no live ammunition.

The following is taken from DOE M 470.4-3A.

The four general firearms safety rules are

- All firearms are always loaded.
- Never point a firearm at anything you are not willing to destroy.
- Keep your finger off the trigger until your sights are on the target.
- Be sure of your target.

Bulk quantities of ammunition, pyrotechnics, or explosives that are not used routinely, and/or are stored for long periods of time, must be stored in facilities that meet design criteria specified in DOE M 440.1-1A. These storage facilities must be located within a designated security area.

The following is taken from DOE O 440.1B.

Establish firearms safety policies and procedures for security operations and training to ensure proper accident prevention controls are in place. Written procedures must address firearms safety, engineering and administrative controls, as well as PPE requirements. At a minimum, procedures must be established for

- storage, handling, cleaning, inventory and maintenance of firearms and associated ammunition;
- activities such as loading, unloading, and exchanging firearms. These procedures must address use of bullet containment devices and those techniques to be used when no bullet containment device is available;
- use and storage of pyrotechnics, explosives, and/or explosive projectiles;
- handling misfires, duds, and unauthorized discharges;
- live fire training, qualification, and evaluation activities;
- training and exercises using engagement simulation systems (ESSs);
- training and exercises using obscurant-generating devices;
- emergency responses at firearms training facilities; and,
- use of firing ranges by personnel other than DOE or DOE contractor protective forces (PF) personnel.

Ensure that personnel responsible for the direction and operation of the firearms safety program are professionally qualified and have sufficient time and authority to implement the established program.

Ensure that firearms instructors and armorers have been certified by the Safeguards and Security National Training Center. Personnel must be professionally qualified through DOE National Training Center, military, or factory training to conduct the level of activity they provide.

Conduct formal appraisals assessing implementation of procedures, personnel responsibilities, and duty assignments to ensure overall policy objectives.

Implement provisions related to firearms training, live fire range safety, qualification, and evaluation activities.

Personnel must successfully complete and demonstrate understanding of initial firearms safety training before being issued any firearms. Authorization to remain in armed status will continue only if the employee demonstrates the technical and practical knowledge of firearms safety semi-annually.

Personnel authorized to carry firearms must have access to instruction manuals or materials for each type of firearm with which they are armed while on duty.

Authorized armed personnel must demonstrate technical and practical knowledge of firearms handling and safety on a semi-annual basis. This demonstration must be supported by limited scope PTs, and the results of such testing must be documented.

All firearms training lesson plans must incorporate safety for all aspects of firearms training task performance standards. Lesson plans must follow the standards and criteria set forth by the Safeguards and Security Central Training Academy's standard training program.

Firearms safety briefings must immediately precede training, qualifications, and evaluation activities involving live fire and/or ESSs.

A safety analysis approved by DOE line management must be developed for the facilities and operation of each live fire range. A safety analysis must be completed and approved prior to implementation of any new training, qualification, or evaluation activity. Results of these analyses must be incorporated into procedures, lesson plans, exercise plans, and limited scope PTs.

Firing range safety procedures must be conspicuously posted at all primary range facilities.

Live fire ranges must be properly sited to protect personnel on the range, as well as personnel and property not associated with the range. Approval for the location and use of live fire range must be obtained from the DOE field element manager.

Develop a safety or risk analysis for all facilities or areas in which firearms will be introduced in accordance with the local protection strategy. Such analyses must be approved by DOE line management.

Ensure that the transportation, handling, placarding, and storage of munitions conform to the applicable requirements of DOE M 440.1-1A.

e. Discuss industrial hazards (e.g., noise and lead exposures) associated with firing ranges and describe appropriate control measures.

The following is taken from the National Institute for Occupational Safety and Health, Preventing Occupational Exposures to Lead and Noise at Indoor Firing Ranges.

Employers and firing range operators should take the following steps to protect their workers and shooters from exposure to hazardous lead concentrations and noise levels at indoor firing ranges:

- Provide workers and shooters with information about hazards and appropriate training to prevent hazardous exposures.
 - Provide general information and specific hazard warnings through workplace postings and targeted training programs.
 - State the precautions and hygiene practices required of the firing range workers and shooters.
 - Train workers and shooters on the actions and means available to eliminate or limit potential exposures.
 - Inform workers and shooters about symptoms that may indicate a health problem. Also inform workers that elevated lead levels can occur without overt symptoms and that a blood lead level test should be done if there is concern about an exposure to lead.
 - Inform pregnant workers and shooters, or those considering pregnancy, about the possible adverse health effects to the fetus.
- Establish effective engineering and administrative controls.
 - If feasible, provide workers with cleaning facilities and lockers and develop a mandatory washing and hygiene program for shooters and workers to limit personal and take-home contamination.

- Install a well-designed supply air and exhaust ventilation system.
- Maintain and replace air filters regularly.
- Design and maintain the firing range structure to limit the transmission of harmful noise levels to adjacent areas.
- Incorporate effective administrative controls in the workers' schedules to limit their exposure time and ensure safe and clean working conditions.
- Provide workers and shooters with PPE and other protective measures.
 - Provide a variety of hearing protection devices including earplugs and earmuffs.
 - Provide skin protection, eye protection, and NIOSH-approved respirators for workers involved in cleaning lead-contaminated surfaces and areas.
 - Provide floor mats, knee pads, and shoe covers when necessary to limit transfer of lead to clothing.
- Provide workers with health and medical monitoring.
 - Provide workers with initial and periodic medical monitoring.
 - Best medical management practices, from organizations such as the Association of Occupational and Environmental Clinics or those provided in the journal *Environmental Health Perspectives* should be recommended for all lead-exposed adults.
 - Provide workers with audiometric evaluations.

f. Describe and apply firearms safety precautions associated with DOE safeguards and security operations and exercises, including handling and storage of ammunition.

Exercises

The following is taken from DOE-STD-1091-96 (Archived).

All exercises shall be governed by a plan that specifically addresses safety issues while remaining consistent with realistic training.

All exercises and related activities shall be regulated by controllers under the supervision of a senior controller who shall have final authority. The senior controller shall signal the beginning and end of the exercises and shall guide and supervise the other controllers.

The senior controller or his or her representative shall conduct pre-exercise briefings to discuss the exercise and to ensure a clear understanding of safety procedures and requirements. Post-exercise briefings of both participants and bystanders shall include a safety recap.

An exercise plan shall be approved by a safety representative designated by the manager of the organization responsible for the exercise. For each force-on-force training exercise, all participants, safety representatives, or controllers shall have the authority to stop an activity if in their opinion unsafe conditions develop.

Individuals with live firearms (shadow force) in an operational area where an exercise is to be conducted must be under the continuous and direct supervision of a controller who preferably is a PF supervisor. This controller must be knowledgeable of security

requirements to ensure that the members of the shadow force understand their roles and do not become involved in the exercise.

Management of facilities/buildings involved in exercises must be informed of exercises in advance. The cognizant DOE official, Federal Bureau of Investigation, and local law enforcement officials shall be notified of pending exercises as appropriate. During exercises, in the event of an unscheduled security alarm, the exercise controller shall suspend the exercise and release the shadow force to respond to the alarm. The exercise will not resume until the members of the shadow force are out of the exercise area.

All firearms used in an exercise shall be inspected at the beginning of the exercise, clearly marked as exercise firearms, closely controlled, and kept separate from any firearms not associated with the exercise. The senior controller shall not permit issuance of blank ammunition and exercise firearms until all live firearms and live ammunition have been collected from participants and accounted for.

All firearms used in laser ESS exercises shall be designated for ESS use; be individually inspected just prior to the beginning of an exercise unless equipped with an approved live-round inhibitor, and kept segregated from firearms that fire live rounds; not be loaded until authorized by the senior controller; and, never be pointed or fired at an individual who is closer than ten feet.

Maintenance or adjustments to ESS laser transmitters shall only be performed by the supplier or by qualified site personnel and approved by the supplier. The transmitters of all laser engagement systems used in departmental exercises shall have warning signs or stickers displayed in accordance with ANSI Standard Z136.1-2007, *American National Standard for Safe Use of Lasers*. In addition, safe distances from these systems shall be calculated using the methodologies in ANSI Z136.1-2007. All equipment containing semiconductor laser diodes shall be certified and shall be subject to ANSI Z136.1-2007.

At the end of an exercise, explosive simulators and exercise firearms shall be collected and accounted for under the direction of the senior controller. Excess blank ammunition and explosive simulators shall be returned to the point of issue. Live firearms and ammunition shall not be reissued until all blank ammunition, simulators, exercise firearms, ESS equipment, and personnel are accounted for.

The exercise plan will include specific direction involving engagement of adversaries, handling of firearms, loading and unloading procedures and locations, and any other scenario specific firearm deployment information. The site range master or designated firearms instructor shall be consulted prior to and should be present during the exercise to ensure that ESS firearm use procedures are compatible with approved live fire training.

Storage

The following is taken from DOE M 470.4-3A.

Firearms, ammunition, pyrotechnics, and explosives must be stored safely according to a security plan approved by the DOE cognizant security authority. They may be stored under the direct control of PF personnel. Alternatively, they may be stored in a vault-type room if an intrusion detection system is installed to detect penetration and the alarm response capability is such that unauthorized removal is unlikely.

Bulk Storage

Bulk quantities of ammunition, pyrotechnics, or explosives that are not used routinely, and/or are stored for long periods of time, must be stored in facilities that meet design criteria specified in DOE M 440.1-1A. These storage facilities must be located within a designated security area.

Storage Containers

Firearms, ammunition, pyrotechnics, and explosives must be stored in GSA-approved firearms storage containers that are bolted or otherwise secured to the structure or under alarm coverage.

Where the weight of the storage container would deter its removal, the requirement to bolt or secure it does not apply. Firearms that are not in such containers or under alarm coverage must be locked in racks, chained, or cabled to prevent unauthorized removal. Racks securing unattended firearms that are not under alarm coverage must be designed to prevent removal via partial disassembly of the firearm.

Storage of Ammunition

Applicable requirements for the storage of commonly used PF munitions can be found in DOE M 440.1-1A and in DoD 6055.9-STD.

- Storage Structures. Refer to DOE M 440.1-1A for guidance on design of structures for storing munitions.
- Hazard Class and Hazard Division. For the purpose of placarding, the United Nations Organization or the NFPA hazard classification systems must be used.
- Storage of Small Arms Ammunition. Articles in hazard class/division 1.4 and storage compatibility group S are considered as inert for storage purposes and require only appropriate fire-protection requirements for distance separation as long as they are stored only with inert items or other 1.4 S items. This applies only if the hazard class/division 1.4 and storage compatibility group S articles remain in their original packaging containers. When stored with items in a storage compatibility group other than S, normal Q-D requirements must be observed. Live ammunition and ESS-related must be stored separately. Separate storage could be placing live and ESS ammunition in separate, secured storage containers in the same location or storing them in separate locations.

Firearms Storage

Firearms not identified for duty or contingency use and having a valid justification for retention must be stored in a manner that will prevent deterioration due to environmental conditions.

Offsite storage of firearms must be specified and authorized by a DOE cognizant security authority.

Dedicated ESS firearms must be stored separately from live firearms. Separate storage may be attained by placing live firearms and ESS firearms in separate, secured storage containers in the same location or by storing in separate locations.

g. Demonstrate understanding by explaining the surface danger zones and safety features of a DOE/NNSA range and how the range safety procedures for that range are implemented.

The following is taken from the U.S. Army Corp of Engineers, Surface Danger Zones.

The surface danger zone (SDZ) is a depiction of the mathematically predicted area a projectile will return to earth either by direct fire or ricochet. The SDZ is the area extending from a firing point to a distance downrange based on the projectiles fired. This area has specific dimensions that provide a contained area for all fragments resulting from the caliber of weapons fired.

While this area is not considered part of the range design, it is one of the deciding factors considered when determining the location of the range facility and the orientation of its lanes and targets. Typically, a composite SDZ is generated to encompass all firing points resulting from the firing of several different caliber weapons. It encompasses all weapons within the largest SDZ footprint. No part of the SDZ may leave the installation property. SDZs of different ranges may overlap, but no SDZ can be located on a part of another range where soldiers are training, unless an adjusted SDZ is authorized by the installation.

h. Describe hazards of safeguards and security programs, including hazards associated with protective forces.

The following is taken from Applicability of the General Rule per Title 10 Code of Federal Regulations Part 835 (10 CFR 835) Section 835.3 for Protective Forces Personnel.

There are potential situations where a DOE PF individual could receive an exposure to ionizing radiation in excess of the 10 CFR 835 limits as a result of emergency actions taken to protect nuclear or other material from theft or diversion.

The following is taken from DOE/EH-0705.

Physical exercises and drills conducted by security forces personnel are very demanding and tasks have contributed significantly to injuries and illnesses. Firearm safety is another major issue confronting security forces personnel. On several occasions, guards have inadvertently shot themselves or others, sometimes due to lack of proper firearm training and/or poor execution of operating procedures. Compounding the firearm safety issues is the fact that some training facilities are not located on site, which makes it more difficult for the guards to obtain the necessary training or live-fire experience.

Security guards are often the first responders to site radiological accidents. If security forces are not properly trained to wear PPE or to respond to radiological emergencies, their risk of exposure and subsequent illness increases significantly.

- i. **Describe scope and applicability of DOE directives applicable to safeguards and security highlighting how these affect worker safety such as DOE M 470.4-3A, Contractor Protective Force and DOE M 470.4-8, Federal Protective Force.**

DOE M 470.4-3A

DOE M 470.4-3A establishes the requirements for the management and operation of DOE contractor PFs. The requirements in this manual apply to DOE elements that have oversight of site and facility management and operations and offices that administer contracts for DOE PF and PF firearms programs for the purposes of protecting safeguards and security interests.

DOE M 470.4-8

DOE M 470.4-8 establishes requirements for the management and operation of the DOE Federal protective forces (FPF). The requirements in this manual apply to DOE elements that have oversight of FPF and FPF firearms programs for the purposes of protecting safeguards and security interests.

29. Occupational safety personnel must demonstrate a familiarity level knowledge of DOE contract management and administration sufficient to interface with contract officer and those contracted in areas of occupational safety.

- a. **Discuss key elements of contractual relationships between DOE and contractors and the impact of cost estimates and budget on project safety.**

The following is taken from Overview of the Department of Energy's Procurement System, Management and Operating Contracts.

Certain characteristics of DOE's M&O contracts differentiate them from other types of contracts used by the Federal government to acquire supplies and services, including the following:

- Work takes place at large government-owned or –controlled facilities.
- Purpose is the accomplishment of a governmental mission.
- Generally deal with research, development, or special production, which often can be the source of significant liabilities.
- Work most often performed at relatively isolated locations around the U.S.
- Work is often of a long-term, continuing nature.
- Contractors employ large workforces that usually remain intact without regard to whether the incumbent contractor is replaced.
- DOE oversees workforce safety and health issues at the facilities.
- Contractors are provided an annual budget; some exceeding \$1 billion.
- A close working relationship exists between the contractor and the government.
- Generally, corporate overhead or general and administrative expenses cannot be charged to the contract.
- There is a higher degree involvement in cost control than under other government contractual arrangements.
- Contractors generally use an integrated accounting system, which mirrors the budgeting system of DOE. The system allows for easy reconciliation in the appropriations process.
- DOE has applied a balanced scorecard management system to its M&O and major facility contractors.

- There is an emphasis on better business practices as well as compliance with contractor purchasing system mandates.
- DOE, working with its facility contractors, has established a procurement evaluation and reengineering team (PERT).
 - The PERT is responsible for promoting procurement process improvements, knowledge management, training, and performance measurement.
 - The PERT also performs reviews of contractor purchasing systems.
- While DOE M&O contract fee policy ensures that fees are reasonable and commensurate with performance, business, and cost risks, all fee in any evaluation period is subject to the contractor meeting performance requirements in two critical areas:
 - Environment, safety, and health
 - Security

b. Describe the role of DOE's occupational safety professional with respect to the evaluation of contractor occupational safety programs for the performance based incentives, cost-plus award fee process or other performance rating processes.

The following is taken from 48 CFR 923.7002.

The clauses entitled 48 CFR 952.223-76, “Conditional Payment of Fee or Profit—Safeguarding Restricted Data and Other Classified Information and Protection of Worker Safety and Health” or 48 CFR 952.223-77, “Conditional Payment of Fee or Profit—Protection of Worker Safety and Health,” implement the requirements of section 234 C of the Atomic Energy Act for the use of a contract clause that provides for an appropriate reduction in the fee or amount paid to the contractor under the contract in the event of a violation by the contractor or any contractor employee of any departmental regulation relating to the enforcement of worker safety and health concerns. The clauses, in part, provide for reductions in the amount of fee, profit, or share of cost savings that is otherwise earned by the contractor for performance failures relating to worker safety and health violations under the Department’s regulations.

The clauses provide for reductions of fee or profit that is earned by the contractor depending on the severity of the contractor’s failure to comply with contract terms or conditions relating to worker safety and health concerns. When reviewing performance failures that would otherwise warrant a reduction of earned fee, the contracting officer must consider mitigating factors that may warrant a reduction below the applicable range specified in the clauses. Some of the mitigating factors that must be considered are specified in the clauses.

The contracting officer must obtain the concurrence of the head of the contracting activity

- prior to effecting any reduction of fee or amounts otherwise payable to the contractor in accordance with the terms and conditions of the clause entitled “Conditional Payment of Fee or Profit—Safeguarding Restricted Data and Other Classified Information and Protection of Worker Safety and Health” or of the clause entitled “Conditional Payment of Fee or Profit—Protection of Worker Safety and Health”; and

- for determinations that no reduction of fee is warranted for a particular performance failure(s) that would otherwise warrant a reduction.

Section 234 C of the Atomic Energy Act provides that DOE shall either pursue civil penalties or a contract fee reduction, but not both.

The contracting officer must coordinate with the Office of Price Anderson Enforcement within the Office of the Assistant Secretary for Health, Safety and Security before pursuing a contract fee reduction in the event of a violation by the contractor or any contractor employee of any departmental regulation relating to the enforcement of worker health and safety concerns.

c. Describe responsibilities of a DOE occupational safety professional associated with contractor compliance with the Price Anderson Amendments Act and describe its penalties and fees as regulated in Price Anderson Amendments Act, 10 CFR 830 and 10 CFR 851.

The following is taken from Brookhaven National Laboratory, Prince-Anderson Amendments Act.

The 1988 Price-Anderson Amendments Act is an amendment to the Atomic Energy Act of 1954. This continues the indemnification of DOE contractors from costs related to public liability. It differed from the original act in two principal ways:

- It made Price-Anderson coverage mandatory for all M&O contractors, subcontractors and suppliers conducting nuclear activities for DOE.
- Congress mandated that DOE change its methods of managing nuclear activities at contractor-operated sites by requiring DOE to undertake enforcement actions against indemnified contractors for violations of nuclear safety requirements. The establishment of enforcement sanctions as a method of ensuring compliance with safety requirements is intended to minimize the risk to workers and the public.

For all M&O contractors, subcontractors and suppliers thereto, DOE has the authority to issue notices of violation when non-compliances with nuclear safety requirements are identified. In addition, for cases involving for-profit contractors, DOE has the authority to issue fines for violations of nuclear safety rules up to \$110,000 per day per occurrence, criminal penalties as well as civil penalties.

10 CFR 820 establishes the legal framework for implementing DOE's Nuclear Safety Enforcement Program. The responsibility for program development and implementation has been assigned to the Enforcement and Investigation Staff in the Office of Environment, Safety and Health. The Enforcement Program relies on existing DOE management systems and technical resources to ensure that the enforcement process properly considers the actual or potential safety significance of a violation when determining an appropriate enforcement sanction.

d. Discuss a program's budget, schedule, appropriateness, and impact on occupational health protection, using actual for an occupational safety program.

This is a site-specific, performance-based KSA. The Qualifying Official will evaluate its completion.

- e. **Identify appropriate contract mechanisms and channels that must be employed or considered when communicating with or directing DOE contractors (e.g., describe appropriate procedures and considerations for issuing a stop work order to a DOE contractor).**

General Contractor Communications

The following is taken from DOE O 226.1B.

DOE line management must set expectations and communicate them to contractors. This will be implemented through formal contract mechanisms and direct communication between DOE and contractor managers.

DOE line management must verify that plans submitted by contractors clearly delineate actions to be taken and describe programs that meet DOE requirements and expectations.

Indicators and performance measures must be established and periodically reviewed by DOE line management and communicated to contractors to provide tools for monitoring performance in meeting expectations.

In addition to collecting and analyzing long-term indicators of interest complex-wide, contractor-specific performance objectives and criteria and appropriate incentives must be identified and specified in contract documents. Objectives and criteria must be challenging and focused on improving performance in known areas of weakness.

If the contractor assurance system is not adequate, DOE line management will provide direction to the contractor through such measures as contractual provisions and required program documents.

Oversight of high consequence activities, such as high hazard nuclear operations, require additional rigor, such as CTA for core nuclear safety functions. Oversight of operations with the potential for high consequence events such as nuclear facilities and operations require additional oversight that must include headquarters awareness and assessment activities.

For high-consequence nuclear operations, the CTAs will maintain awareness of the content of applicable DOE line oversight programs, plans, and processes, and contractor assurance systems by monitoring, evaluation and trend analyses, and by participation in oversight activities. The CTAs will also maintain awareness of the state of implementation of these line management programs, plans, and processes, and contractor assurance systems by monitoring associated assessment reports. The CTAs will also conduct and participate in various DOE headquarters line oversight review activities as defined in the associated headquarters oversight programs. Based on these activities the CTA will communicate identified issues and trends to line management, provide advice concerning technical solutions or options, and be able to follow up to ensure proper closure or implementation.

Deficiencies in programs or performance identified during operational awareness activities must be communicated to the contractor for resolution through a structured issues management process, which can be managed by the DOE field organization or the contractor.

Employee Concerns Program

The following is taken from DOE G 442.1-1.

The DOE recognizes that free and open expression of DOE Federal and contractor and subcontractor employee concerns is essential to safe and efficient accomplishment of DOE's missions. DOE employees and any contractor or subcontractor fulfilling DOE's mission have the right and responsibility to report concerns relating to the environment, safety, health, or management of Department operations. The Employee Concerns Program is designed to

- encourage open communication
- inform employees of the proper forum for consideration of their concerns
- ensure employees can raise issues without fearing reprisal
- address employee concerns in a timely and objective manner
- provide employees an avenue for consideration of concerns that fall outside existing systems

Stop Work Order

The following is taken from DOE G 440.1-8.

Workers may stop work when they discover employee exposures to imminently dangerous conditions or other serious hazards provided that the stop work is exercised in a justifiable and responsible manner consistent with procedures in the safety and health program.

Any stop work authority should be exercised in a justifiable and responsible manner. All workers, supervisors, managers, and OSH professionals are responsible for being cognizant of the conditions in their workplaces and for being prepared to stop work when these conditions pose an imminent danger of death or serious physical harm. When a "reasonable person" views the circumstances as imminent danger of death or serious physical harm, a stop work order should be issued. The term "reasonable person" is a subjective term the meaning of which depends on the specific context in which the term is used.

Whenever workers see a need for a stop work order, they should request one from their supervisors. Before a stop work order is issued, the person issuing it should ensure that the work stoppage itself would not negatively impact the safety and health of workers. Contractors should have procedures in place that address stop work authority, and workers should be trained to those procedures.

Mandatory Performance Activities:

- f. Explain DOE O 226.1B, *Implementation of Department of Energy Oversight Policy* as it applies to evaluating contractor performance against contract requirements including that of sub tier contractors.**

The following is taken from DOE O 226.1B.

Oversight processes implemented by applicable DOE line management organizations must

- evaluate contractor programs and management systems, including site assurance systems, for effectiveness of performance. Such evaluations are based on operational awareness activities; assessments of facilities, operations, and programs; and assessments of the contractor assurance system. The level and/or mix of oversight will be adjusted based upon the maturity and operational performance of contractor programs and management systems.
- document plans, including schedules for planned assessments and focus areas for operational oversight.
- include documented self-assessment of processes and systems. DOE headquarters line organizations conduct oversight processes that are focused primarily on the DOE field elements and also look at contractor activities to the extent necessary, in order to evaluate the implementation and effectiveness of field element line management oversight.
- include site management systems, such as ISM and QA, external independent oversight processes as appropriate, and internal independent oversight as required.
- include an issue management process that is interoperable with the contractor's system, is capable of categorizing findings based on risk and priority, and ensures that problems are evaluated and corrected on a timely basis; for higher significance findings ensures
 - a thorough analysis of the underlying causal factors is completed;
 - timely corrective actions that will address the cause(s) of the findings and prevent recurrence are identified and implemented;
 - after completion of a corrective action or a set of corrective actions, conduct an effectiveness review using trained and qualified personnel that can verify the corrective action/corrective action plan has been effectively implemented to prevent reoccurrences;
 - document the analysis process and results, and maintain and track completion of plans and schedules for the corrective actions and effectiveness reviews in a readily accessible system; and
 - when findings and/or corrective actions apply to more than one secretarial office, a lead office must be appointed by mutual agreement.
- be tailored according to the effectiveness of contractor assurance systems, the hazards at the site/activity, and the degree of risk.
- address in the documented oversight program plans and schedules the role of the CTAs and their support staff for core nuclear safety functions.

30. Occupational safety personnel must demonstrate working level knowledge of industrial hygiene hazards and controls.

a. Describe industrial hygiene programs, including health effects, instrumentation and monitoring, and safety controls.

The following is taken from Occupational Safety and Health Administration, OSHA 3143.

Health Effects

To be effective in recognizing and evaluating on-the-job hazards and recommending controls, industrial hygienists must be familiar with the hazards' characteristics. Major

job risks can include air contaminants, and chemical, biological, physical, and ergonomic hazards.

Air Contaminants

These are commonly classified as either particulate or gas and vapor contaminants. The most common particulate contaminants include dusts, fumes, mists, aerosols, and fibers. Dusts are solid particles that are formed or generated from solid organic or inorganic materials by reducing their size through mechanical processes such as crushing, grinding, drilling, abrading or blasting.

Fumes are formed when material from a volatilized solid condenses in cool air. In most cases, the solid particles resulting from the condensation react with air to form an oxide.

The term mist is applied to a finely divided liquid suspended in the atmosphere. Mists are generated by liquids condensing from a vapor back to a liquid or by breaking up a liquid into a dispersed state such as by splashing, foaming or atomizing. Aerosols are also a form of a mist characterized by highly respirable, minute liquid particles.

Fibers are solid particles whose length is several times greater than their diameter.

Gases are formless fluids that expand to occupy the space or enclosure in which they are confined. Examples are welding gases such as acetylene, nitrogen, helium, and argon; and carbon monoxide generated from the operation of internal combustion engines or by its use as a reducing gas in a heat-treating operation. Another example is hydrogen sulfide which is formed wherever there is decomposition of materials containing sulfur under reducing conditions.

Liquids change into vapors and mix with the surrounding atmosphere through evaporation. Vapors are the volatile form of substances that are normally in a solid or liquid state at room temperature and pressure. Vapors are the gaseous form of substances which are normally in the solid or liquid state at room temperature and pressure. They are formed by evaporation from a liquid or solid and can be found where parts cleaning and painting takes place and where solvents are used.

Chemical Hazards

Harmful chemical compounds in the form of solids, liquids, gases, mists, dusts, fumes, and vapors exert toxic effects by inhalation (breathing), absorption (through direct contact with the skin), or ingestion (eating or drinking). Airborne chemical hazards exist as concentrations of mists, vapors, gases, fumes, or solids. Some are toxic through inhalation and some of them irritate the skin on contact; some can be toxic by absorption through the skin or through ingestion, and some are corrosive to living tissue.

The degree of worker risk from exposure to any given substance depends on the nature and potency of the toxic effects and the magnitude and duration of exposure.

Information on the risk to workers from chemical hazards can be obtained from the MSDS that OSHA's hazard communication standard requires be supplied by the manufacturer or importer to the purchaser of all hazardous materials. The MSDS is a summary of the important health, safety, and toxicological information on the chemical or the mixture's ingredients. Other provisions of the hazard communication standard

require that all containers of hazardous substances in the workplace have appropriate warning and identification labels.

Biological Hazards

These include bacteria, viruses, fungi, and other living organisms that can cause acute and chronic infections by entering the body either directly or through breaks in the skin. Occupations that deal with plants or animals or their products or with food and food processing may expose workers to biological hazards. Laboratory and medical personnel also can be exposed to biological hazards. Any occupations that result in contact with bodily fluids pose a risk to workers from biological hazards.

In occupations where animals are involved, biological hazards are dealt with by preventing and controlling diseases in the animal population as well as proper care and handling of infected animals. Also, effective personal hygiene, particularly proper attention to minor cuts and scratches, especially those on the hands and forearms, helps keep worker risks to a minimum.

In occupations where there is potential exposure to biological hazards, workers should practice proper personal hygiene, particularly hand washing. Hospitals should provide proper ventilation, proper PPE such as gloves and respirators, adequate infectious waste disposal systems, and appropriate controls including isolation in instances of particularly contagious diseases such as tuberculosis.

Physical Hazards

These include excessive levels of ionizing and nonionizing electromagnetic radiation, noise, vibration, illumination, and temperature.

In occupations where there is exposure to ionizing radiation, time, distance, and shielding are important tools in ensuring worker safety. Danger from radiation increases with the amount of time one is exposed to it; hence, the shorter the time of exposure the smaller the radiation danger.

Distance also is a valuable tool in controlling exposure to both ionizing and non-ionizing radiation. Radiation levels from some sources can be estimated by comparing the squares of the distances between the worker and the source. For example, at a reference point of 10 feet from a source, the radiation is 1/100 of the intensity at 1 foot from the source.

Shielding also is a way to protect against radiation. The greater the protective mass between a radioactive source and the worker, the lower the radiation exposure.

Nonionizing radiation also is dealt with by shielding workers from the source. Sometimes limiting exposure times to nonionizing radiation or increasing the distance is not effective. Laser radiation, for example, cannot be controlled effectively by imposing time limits. An exposure can be hazardous that is faster than the blinking of an eye. Increasing the distance from a laser source may require miles before the energy level reaches a point where the exposure would not be harmful.

Noise, another significant physical hazard, can be controlled by various measures. Noise can be reduced by installing equipment and systems that have been engineered, designed, and built to operate quietly; by enclosing or shielding noisy equipment; by making

certain that equipment is in good repair and properly maintained with all worn or unbalanced parts replaced; by mounting noisy equipment on special mounts to reduce vibration; and by installing silencers, mufflers, or baffles.

Substituting quiet work methods for noisy ones is another significant way to reduce noise, for example, welding parts rather than riveting them. Also, treating floors, ceilings, and walls with acoustical material can reduce reflected or reverberant noise. In addition, erecting sound barriers at adjacent work stations around noisy operations will reduce worker exposure to noise generated at adjacent work stations.

It is also possible to reduce noise exposure by increasing the distance between the source and the receiver, by isolating workers in acoustical booths, limiting workers' exposure time to noise, and by providing hearing protection. OSHA requires that workers in noisy surroundings be periodically tested as a precaution against hearing loss.

Another physical hazard, radiant heat exposure in factories such as steel mills, can be controlled by installing reflective shields and by providing protective clothing.

Ergonomic Hazards

The science of ergonomics studies and evaluates a full range of tasks including, but not limited to, lifting, holding, pushing, walking, and reaching. Many ergonomic problems result from technological changes such as increased assembly line speeds, adding specialized tasks, and increased repetition; some problems arise from poorly designed job tasks. Any of those conditions can cause ergonomic hazards such as excessive vibration and noise, eye strain, repetitive motion, and heavy lifting problems. Improperly designed tools or work areas also can be ergonomic hazards. Repetitive motions or repeated shocks over prolonged periods of time as in jobs involving sorting, assembling, and data entry can often cause irritation and inflammation of the tendon sheath of the hands and arms, a condition known as carpal tunnel syndrome.

Ergonomic hazards are avoided primarily by the effective design of a job or jobsite and better designed tools or equipment that meet workers' needs in terms of physical environment and job tasks. Through thorough worksite analyses, employers can set up procedures to correct or control ergonomic hazards by using the appropriate engineering controls; teaching correct work practices; employing proper administrative controls; and, if necessary, providing and mandating PPE. Evaluating working conditions from an ergonomics standpoint involves looking at the total physiological and psychological demands of the job on the worker.

Overall, industrial hygienists point out that the benefits of a well-designed, ergonomic work environment can include increased efficiency, fewer accidents, lower operating costs, and more effective use of personnel.

In sum, IH encompasses a broad spectrum of the working environment. Early in its history OSHA recognized IH as an integral part of a healthful work setting. OSHA places a high priority on using IH concepts in its health standards and as a tool for effective enforcement of job safety and health regulations.

Instrumentation and Monitoring

The following is taken from the National Institute for Occupational Safety and Health, NIOSH Publication Number 2003-154.

Proper advance planning minimizes sampling and measurement costs and labor and contributes to a smooth, successful survey. Many things must be considered before collecting field samples. The first step is to define sampling objectives. These may include documenting exposures in particular work settings, determining compliance/non-compliance with existing Federal or local standards or recommended exposure limits, or trying to determine the source of a problem. Sampling parameters that should be defined might include type of sample, contaminant(s) to be sampled, duration of samples, potential interferences and expected contaminant concentrations. Once these parameters are defined, then the proper analytical method and sampling media can be selected. Other general information needed to plan a survey properly includes the number of employees, the sampling strategy plan, process flow diagram, MSDSs on all process materials, the physical states of the substances to be sampled, and potential hazards involved in collecting and shipping the samples.

An accredited analytical laboratory should be used to conduct analysis of collected samples, and it is essential to consult with the analytical laboratory before sampling to ensure that the measurement methods available can meet the defined sampling needs. This step should be an early part of survey planning. The laboratory can also assist in choosing sampling media that are compatible with the sampling needs and the measurement methods available.

Whether through consultation with the laboratory or through reading the specific measurement method, the sampling media will be specifically identified (e.g., pore size and type of filter, concentration and amount of liquid media required, and specific type and amount of solid sorbent).

If specific brand name products are called for, no substitutions should be made. Most sampling media are well defined through research and testing; deviations from specifications are undesirable. For example, most organic contaminants are sampled with a dual section tube containing 100 mg front and 50 mg backup sections of 20/40 mesh activated coconut shell charcoal. If larger mesh charcoal or a different type of charcoal were to be used, the sampling capacity and recovery efficiencies for the contaminant of interest might change from that specified in the method.

The physical state of the contaminant(s) being sampled may also be a factor in determining the media required. The sampling pump used to collect the sample must also be compatible with the sampling needs and the media used. Specifically, the pump must be capable of maintaining the desired flow rate over the time period needed using the sampling media specified. Some pumps may not be able to handle the large pressure drop of the media. This will be true for fine mesh solid sorbent tubes, small pore size filters or when attempting to take a short-term sample on a sorbent tube of a higher than normal pressure drop at a flow rate of 1 L/min or greater. All high flow pumps (1 to 4 L/min) can handle at least 3 kPa (12 inches of water) pressure drop at 1 L/min for 8 hours. Some pumps can handle up to 7.5 kPa (30 inches of water) pressure drop at flows up to 2 or 3 L/min. Most low flow pumps (0.01 to 0.2 L/min) can handle the pressure drops of

available sorbent tubes without problems except that the nominal flow rate may decrease for certain models. All pumps should be calibrated with representative sampling media prior to use. It is good practice to check the pump calibration before and after use each day. As a minimum, calibration should be done before and after each survey.

Types and uses of Solid Sorbents

Activated charcoal

By far the most commonly used solid sorbent. Very large surface area:wt. ratio. Reactive surface, high adsorptive capacity. This surface reactivity means that activated charcoal is not useful for sampling reactive compounds because of poor desorption efficiency. The high capacity, however, makes it the sorbent of choice for those compounds that are stable enough to be collected and recovered in high yield. Breakthrough capacity is a function of type (source) of the charcoal, its particle size and packing configuration in the sorbent bed. Humidity may affect the adsorption as well.

Silica gel

Less reactive than charcoal. Because of its polar nature, it is hygroscopic and shows a decrease in breakthrough capacity for non-water soluble substances with increasing humidity.

Porous polymers

Lower surface area and much less reactive surface than charcoal. Adsorptive capacity is, therefore, generally lower, but reactivity is much lower as well.

Ambersorbs

Properties midway between charcoal and porous polymers.

Coated Sorbents

One of the sorbents upon which a layer of a reagent has been deposited. The adsorptive capacity of such systems usually approaches the capacity of the reagent to react with the particular analyte.

Molecular Sieves

Zeolites and carbon molecular sieves retain adsorbed species according to molecular size. A limiting factor is that the water molecule is of similar size to many small organic compounds and is usually many orders of magnitude higher in concentration than the species of interest. This unfavorable situation may result in the displacement of the analyte by water molecules. Drying tubes may be used during sampling to eliminate the effects of humidity.

Thermal Desorption

Thermal desorption tubes may contain several different sorbents in order to collect a wide range of different chemicals. These tubes are generally used in situations where unknown chemicals or a wide variety of organics are present (e.g., in indoor environmental air quality investigations). Analysis is often by gas chromatography/mass spectrometry.

Types and uses of Aerosol Samplers

Membrane Filters

By far the most frequently used filters. This class of filters includes those made from used for sampling asbestos, minerals, polyaromatic hydrocarbons, particulates not otherwise regulated, and elements for ICP analysis.

Glass and Quartz Fiber Filters

Quartz filters have replaced glass in many applications. They are used in applications such as sampling for mercaptans and diesel exhaust.

Polycarbonate Straight Pore Filters

Because of their characteristics, these filters are good for the collection of particles to be analyzed by electron microscopy and x-ray fluorescence.

Respirable Dust Samplers

The 10-mm nylon cyclone and (preferably) conductive cyclones with a 50 percent cut at 4 μm are used with polyvinyl chloride filters to collect various forms of silica. Inhalable dust samplers The Institute of Occupational sampler is used, in conjunction with a polyvinyl chloride filter, for sampling formaldehyde on dust.

Safety Controls

The following is taken from DOE-STD-6005-2001.

DOE and contractor line management are required to use appropriate engineering, administrative, work practice, and/or personal protective control methods to limit hazardous exposures to acceptable levels.

Often, there are several alternative approaches to preventing or controlling hazardous exposures. In such cases, front-line workers and supervisors are often the most knowledgeable about which options would be the most effective. Such worker involvement can help in identifying useful prevention and control measures, promote communication about the rationale behind the choice of a particular alternative, and encourage worker acceptance of the decision.

Based on this input, the senior industrial hygienist should recommend to facility management the best prevention and control measures for reducing/minimizing the hazardous exposures of employees.

Hierarchy of Controls

DOE and OSHA require that control measures be prioritized in accordance with the following hierarchy of controls:

Engineering controls:

- Change to a less hazardous process or substitute a less hazardous material or piece of equipment.
- Isolate or enclose the process or operation to prevent worker exposure to hazardous agents.
- Use mechanical ventilation or other engineered controls to prevent or reduce worker exposure to hazardous agents.

Work practice and administrative controls that limit worker exposures:

Although administrative controls can minimize worker exposures, they are often unreliable and difficult to implement. For this reason, engineering controls are preferable to administrative and work practice controls.

- Develop work practices and procedures to reduce/minimize hazardous exposures.
- Maintain administrative controls.

Personal protective equipment:

- Use PPE.
- Use of PPE is generally considered the last line of defense because it places the burden of hazard control directly on the worker. Its use should be limited to
 - the period necessary to install, evaluate or repair engineering controls
 - work situations such as maintenance and repair activities and hazardous waste and emergency response operations in which engineering controls are not feasible
 - work situations in which engineering controls and supplemental work practice controls are not sufficient to reduce exposures to or below occupational exposure limits
 - emergency or escape situations

b. Discuss how IH program and controls interface with ISM and site safety programs.

The following is taken from DOE-STD-6005-2001.

DOE-STD-6005-2001, *Industrial Hygiene Practices*, recommends industrial hygiene practices to support components of the worker protection program required by DOE O 440.1B. Further, it is consistent with and supports the principles and content of DOE P 450.4 directives (i.e., ISMS).

c. Discuss industrial hygiene fundamentals in terms of:

- **Basic terminology**
- **Nature, recognition, evaluation and control of hazards**
- **Necessary elements for implementing and maintaining an effective industrial hygiene program.**

Basic Terminology

The following terms are taken from Navy Medicine, Glossary of Common Industrial Hygiene Terms.

Action Level

Unless otherwise stated in a regulation, the action level is one-half of the PEL or TLV. It is the exposure concentration at which control measures and medical surveillance are required.

Bloodborne Pathogens

Pathogenic micro-organisms that are present in human blood and can cause disease in humans. These pathogens include, but are not limited to, hepatitis B virus and human immune deficiency virus.

Capture Velocity

The air velocity, at a specified distance from a hood, necessary to overcome dispersive forces and capture the contaminant.

Ceiling Limit

An exposure to a toxic material which cannot be exceeded for any length of time.

dBA - Decibels, A-weighted Network

The sound pressure level in decibels, as measured on a sound level meter using the A-weighted network (scale). This network attempts to reflect the human ear's decreased sensitivity to low frequency sounds.

Friable Asbestos

Loosely bound asbestos whose substrate may easily crumble or pulverize. Friable asbestos is a health hazard because it easily releases fibers into the air.

Heat Stress

Any combination of air temperature, thermal radiation, humidity, airflow, and workload that may stress the body as it attempts to regulate body temperature. Heat stress becomes excessive when the body's capability to adjust is exceeded, resulting in an increase of body temperature.

HEPA—High-efficiency Particulate Air Filter

A filter capable of trapping and retaining at least 99.97 percent of 0.3 micrometer diameter particles. The most recent designations for HEPA filters are N100 (not oil resistant), R100 (oil resistant), and P100 (oil proof).

Mist

Finely divided liquid droplets suspended in air and generated by condensation or by atomization.

Permissible Exposure Limit

The PEL-time weighted average is considered the maximum concentration to which employees can be safely exposed to a hazardous airborne contaminant up to eight-hours per day, forty hours per week.

Reactive

A chemical that can vigorously polymerize, decompose, condense, or become self-reactive under conditions of shock, pressure, or high temperature.

Reproductive Hazard

Any occupational stressor that has the potential to adversely affect the human reproductive process.

STEL—Short Term Exposure Limit

The concentration to which it is believed that workers can be exposed continuously for a short period of time, usually 15 minutes, without suffering from irritation, chronic or irreversible tissue damage, or narcosis of sufficient degree to increase the likelihood of

accidental injury, impair self-rescue, or materially reduce work efficiency; provided that the 8-hour time-weighted average is not exceeded.

d. Describe sources of nonionizing radiation, including lasers and the hazards of equipment and its use.

The following is taken from the U.S. Department of Labor, Occupational Safety and Health Administration, Non-ionizing Radiation.

Non-ionizing radiation is described as a series of energy waves composed of oscillating electric and magnetic fields traveling at the speed of light. Non-ionizing radiation includes the spectrum UV, visible light, IR, microwave, (MW) radio frequency (RF), and extremely low frequency (ELF). Lasers commonly operate in the UV, visible, and IR frequencies. Non-ionizing radiation is found in a wide range of occupational settings and can pose a considerable health risk to potentially exposed workers if not properly controlled.

Extremely Low Frequency Radiation (ELF)

Extremely low frequency radiation at 60 HZ is produced by power lines, electrical wiring, and electrical equipment. Common sources of intense exposure include ELF induction furnaces and high-voltage power lines.

Radiofrequency and Microwave Radiation

Microwave radiation is absorbed near the skin, while RF radiation may be absorbed throughout the body. At high enough intensities both will damage tissue through heating. Sources of RF and MW radiation include radio emitters and cell phones.

Infrared Radiation (IR)

The skin and eyes absorb IR radiation as heat. Workers normally notice excessive exposure through heat sensation and pain. Sources of IR radiation include furnaces, heat lamps, and IR lasers.

Visible Light Radiation

The different visible frequencies of the electromagnetic spectrum are seen by our eyes as different colors. Good lighting is conducive to increased production, and may help prevent incidents related to poor lighting conditions. Excessive visible radiation can damage the eyes and skin.

Ultraviolet Radiation (UV)

Ultraviolet radiation has a high photon energy range and is particularly hazardous because there are usually no immediate symptoms of excessive exposure. Sources of UV radiation include the sun, black lights, welding arcs, and UV lasers.

Laser Hazards

The following is taken from OSHA Technical Manual, section III, chapter VI, Laser Hazards.

In some laser operations, particularly in the research laboratory, general safety and health guidelines should be considered.

Industrial Hygiene

Potential hazards associated with compressed gases, cryogenic materials, toxic and carcinogenic materials and noise should be considered. Adequate ventilation shall be installed to reduce noxious or potentially hazardous fumes and vapors, produced by laser welding, cutting and other target interactions, to levels below the appropriate TLVs or PELs.

Explosion Hazards

High-pressure arc lamps and filament lamps or laser welding equipment shall be enclosed in housings which can withstand the maximum pressures resulting from lamp explosion or disintegration. The laser target and elements of the optical train which may shatter during laser operation shall also be enclosed.

Non-beam Optical Radiation Hazards

This relates to optical beam hazards other than laser beam hazards. Ultraviolet radiation emitted from laser discharge tubes, pumping lamps and laser welding plasmas shall be suitably shielded to reduce exposure to levels below the ANSI Z 136.1 PELs, and/or TLVs.

Collateral Radiation

Radiation, other than laser radiation, associated with the operation of a laser or laser system (e.g., RF energy associated with some plasma tubes), x-ray emission associated with the high voltage power supplies used with excimer lasers, shall be maintained below the applicable protection guides. The appropriate protection guide for RF and microwave energy is that given in American National Standard, ANSI/IEEE C95.1, *Safety Levels with Respect to Human Exposure to Radio Frequency Electromagnetic Fields, 300 kHz to 100 GHz*, the appropriate protection guides for exposure to X-ray emission is found in 29 CFR 1910.1096, "Ionizing Radiation," and the applicable state codes. Lasers and laser systems which, by design, would be expected to generate appreciable levels of collateral radiation, should be monitored.

Electrical Hazards

The intended application of the laser equipment determines the method of electrical installation and connection to the power supply circuit. All equipment shall be installed in accordance with the NEC and the Occupational Safety and Health Act.

Flammability of Laser Beam Enclosures

Enclosure of class IV laser beams and terminations of some focused class IIIB lasers, can result in potential fire hazards if the enclosure materials are exposed to irradiances exceeding 10 W/cm^2 . Plastic materials are not precluded as an enclosure material, but their use and potential for flammability and toxic fume release following direct exposure should be considered. Flame-resistant materials and commercially available products specifically designed for laser enclosures should also be considered.

Biological Effects of the Laser Beam

Eye Injury

Because of the high degree of beam collimation, a laser serves as an almost ideal point source of intense light. A laser beam of sufficient power can theoretically produce retinal

intensities at magnitudes that are greater than conventional light sources, and even larger than those produced when directly viewing the sun. Permanent blindness can be the result.

Thermal Injury

The most common cause of laser-induced tissue damage is thermal in nature, where the tissue proteins are denatured due to the temperature rise following absorption of laser energy.

The thermal damage process (burns) is generally associated with lasers operating at exposure times greater than 10 microseconds and in the wavelength region from the near UV to the far IR (0.315 μm -103 μm). Tissue damage may also be caused by thermally induced acoustic waves following exposures to sub-microsecond laser exposures.

With regard to repetitively pulsed or scanning lasers, the major mechanism involved in laser-induced biological damage is a thermal process wherein the effects of the pulses are additive. The principal thermal effects of laser exposure depend upon the following factors:

- The absorption and scattering coefficients of the tissues at the laser wavelength
- Irradiance or radiant exposure of the laser beam
- Duration of the exposure and pulse repetition characteristics, where applicable
- Extent of the local vascular flow
- Size of the area irradiated

Other

Other damage mechanisms have also been demonstrated for other specific wavelength ranges and/or exposure times. For example, photochemical reactions are the principal cause of threshold level tissue damage following exposures to either actinic UV radiation (0.200 μm -0.315 μm) for any exposure time or blue light visible radiation (0.400 μm -0.550 μm) when exposures are greater than 10 seconds.

To the skin, UV-A (0.315 μm -0.400 μm) can cause hyperpigmentation and erythema.

Exposure in the UV-B range is most injurious to skin. In addition to thermal injury caused by UV energy, there is the possibility of radiation carcinogenesis from UV-B (0.280 μm - 0.315 μm) either directly on DNA or from effects on potential carcinogenic intracellular viruses.

Exposure in the shorter UV-C (0.200 μm -0.280 μm) and the longer UV-A ranges seems less harmful to human skin. The shorter wavelengths are absorbed in the outer dead layers of the epidermis (stratum corneum) and the longer wavelengths have an initial pigment-darkening effect followed by erythema if there is exposure to excessive levels.

The hazards associated with skin exposure are of less importance than eye hazards; however, with the expanding use of higher-power laser systems, particularly UV lasers, the unprotected skin of personnel may be exposed to extremely hazardous levels of the beam power if used in an unenclosed system design.

e. Describe hazards, sampling, and monitoring and controls for laboratory and production operations.

The following is taken from Dartmouth College, ChemLab, Safety Hazards in the Lab.

Accidents in the laboratory are often the result of carelessness or ignorance either by you or by your neighbors. Stay alert and pay constant attention to your own and to your neighbors' actions. The safety precautions outlined below will be worthless unless you plan, understand, and think through the consequences of every operation before you perform it. The common accidents, which often occur simultaneously, are fire, explosion, chemical and thermal burns, cuts from broken glass tubing and thermometers, absorption of toxic, but non-corrosive chemicals through the skin, and inhalation of toxic fumes. Less common, but obviously dangerous, is the ingestion of a toxic chemical. Each of these types is discussed in a general way below, and more specific reference to certain hazards will be found in the individual experiments.

Fire

There should never be open flames in the lab. Make it a working rule that water is the only nonflammable liquid technicians are likely to encounter. Treat all other liquids in the vicinity of a flame as gasoline. Specifically, never heat any organic solvent in an open vessel, such as a test tube, Erlenmeyer flask, or beaker, with a flame. Such solvents should be heated in a hood with a steam bath, not a hot plate. Never keep volatile solvents, such as ether, acetone, or benzene in an open beaker or Erlenmeyer flask. The vapors can and will creep along the bench, ignite, and flash back if they reach a flame or spark.

Explosion

Never heat a closed system or conduct a reaction in a closed system, unless specifically directed to perform the latter process and then only with frequent venting. Before starting a distillation or a chemical reaction, make sure that the system is vented. The results of an explosion are flying glass and spattered chemicals, usually hot and corrosive.

Chemical and Thermal Burns

Many inorganic chemicals such as the mineral acids and alkalis are corrosive to the skin and eyes. Likewise, many organic chemicals, such as acid halides, phenols, and so forth are corrosive and often toxic. If these are spilled on the desk, in the hood, or on a shelf, call for assistance in cleaning them up.

Be careful with hot plates to avoid burns. Always assume that hot plates are HOT.

Cuts

The most common laboratory accident is probably the cut received while attempting to force a cork or rubber stopper onto a piece of glass tubing, a thermometer, or the side-arm of a distilling flask. Be sure to make a proper-sized hole, lubricate the cork or stopper, and use a gentle pressure with rotation on the glass part. Severed nerves and tendons are common results of injuries caused by improper manipulation of glass tubes and thermometers. Always pull rather than push on the glass when possible.

Absorption of Chemicals

Keep chemicals off the skin. Many organic substances are not corrosive, do not burn the skin, or seem to have any serious effects. They are, however, absorbed through the skin, sometimes with dire consequences. Others will give a serious allergic reaction upon repeated exposure, as evidenced by severe dermatitis. Be careful about touching your face or eyes in the lab; make sure your hands are clean first. Gloves will be available in the lab. However, gloves provide only a temporary layer of protection against chemicals on skin and may be permeable to some chemical reagents, without visible deterioration. If gloves come in contact with a chemical reagent, remove them, wash hands, and get a new pair of gloves immediately.

Inhalation of Chemicals

Keep your nose away from chemicals. Many of the common solvents are extremely toxic if inhaled in any quantity or over a period of time. Do not evaporate excess solvents in the laboratory; use the hood or a suitable distillation apparatus with a condenser. Some compounds, such as acetyl chloride, will severely irritate membranes in your eyes, nose, throat, and lungs, while others, such as benzyl chloride, are severe lachrymators (i.e., they induce eye irritation and tears). When in doubt, use the hood or consult with the laboratory instructor about the use of chemicals required for your work. Specific safety information about chemicals used is included in each experiment write up.

Ingestion of Chemicals

The common ways of accidentally ingesting harmful chemicals are: 1) by pipet, 2) from dirty hands, and 3) contaminated food or drink. Below are ways to avoid accidental ingestion of chemical reagents:

- Pipets must be fitted with suction bulbs to transfer chemicals. **DO NOT USE MOUTH SUCTION.**
 - Wash your hands before handling anything that goes into your mouth. Wash your hands when you leave the laboratory.
 - Do not eat or drink in the laboratory. Use the water fountains for a drink—not a laboratory faucet. Remove gloves and wash your hands before using the water fountain or bathroom.
 - Never use chemicals from the laboratory or stockroom on food. The source containers may be contaminated or mislabeled.
 - Never use laboratory glassware as a food or drink container.
 - Never store food or drink in a laboratory refrigerator or ice machine. Never consume ice from a laboratory ice machine.
- f. Discuss an industrial hygiene workplace assessment that includes developing a sampling and analysis plan and performing sampling.**

Workplace Assessment

The following is taken from DOE-STD-6005-2001.

Management should annually perform and document a self-assessment to ensure the effectiveness of the implementation of IH practices and assure quality. Such self-assessments should include reviews of

- adequacy and use of IH resources;

- all exposure assessment records, including medical exposure data, audiometric testing records, illness and injury logs and supporting information, and any other records relevant to the maintenance of IH functions;
- compliance with applicable IH requirements and established performance measures;
- success in receiving and responding to employee occupational health concerns;
- industrial hygiene evaluation records to assess progress in abating health hazards;
- all required written programs that include IH elements; and
- training program effectiveness.

Management should correct any deficiencies identified by the program self-assessment in a timely manner

Sampling and Analysis Plan

The following is taken from the NIOSH Manual of Analytical Methods.

The development and evaluation of analytical methods that are useful, reliable, and accurate for IH monitoring problems require the application of some general guidelines and evaluation criteria. The guiding objective in this work requires that, over a specified concentration range, the method provide a result that differs no more than ± 25 percent from the true value 95 times out of 100. The application of consistent evaluation criteria and guidelines is particularly important when methods are developed by different individuals and organizations (e.g., contractors or outside laboratories) and compiled into a single manual. Adherence to guidelines should minimize overlooking potential problems in the methodology during its development, as well as provide cohesiveness and uniformity to the method that is developed.

In the development of a sampling and analytical method, there is a logical progression of events that cover a search of the literature to gather pertinent information and the preliminary experimentation for selection of analysis technique and sampling medium. To initiate the development of a method, the identity of the analyte must be as fully defined as possible. Physical and chemical properties of the analyte should be defined so that procedures for proper handling and use of the analyte can be prepared. These also aid in establishment of analyte purity. Potential sources of this information include chemical reference books, health hazard evaluation reports, bulk sample analyses, MSDSs, chemical process information, etc.

Since innovation is a key element in the sampling and analytical method development process, detailed experiments for the initial development of the sampling approach and optimization of the analytical procedure are better left to the discretion of the researcher. During development, it should be recognized that appropriate, statistically designed experiments will optimize the amount of information obtained. Therefore, consultation with a statistician about appropriately designed experiments will be of value during this phase of the research.

Preliminary Experimentation

Several key points, including calibration and selection of measurement technique and sampling media, should be studied during the initial method development experiments. The selection of sampling medium and procedure is a decision that usually is made early in the method development process. The physical state of the analyte plays an important

factor in the selection of an appropriate sampler. Analytes that can exist in more than one physical state may require a combination of sampling media in one sampler for efficient collection. Commonly available and easily used samplers should be investigated initially, where possible. As the preliminary testing of a sampling method progresses, further modification in the sampling medium or sampler design may be required and may affect the measurement procedure. Sampler design and media selection considerations should include DOT regulations and restrictions for shipment back to a laboratory for analysis.

Since IH analytical methods are geared toward measuring personal exposure, the size, weight, and convenience of the sampler are important elements in sampler design. The personal sampler should allow freedom of movement and should be unobtrusive, unbreakable, and not prone to leakage. The pressure drop across the sampler should not be so great as to limit sample collection times to ten hours with personal sampling pumps. For situations where only a short term sample will be required, this ten-hour recommendation can be reduced to one hour. The use of potentially toxic reagents should be avoided unless they can be used safely. Reagents used should not pose any exposure hazard to the worker wearing the sampler or to the industrial hygienist taking the samples.

Method Evaluation

After the initial development experiments for the method have been completed and a method has been proposed, the sampling and analysis approach should be evaluated to ensure that the data collected provides reliable, precise, and accurate results. Specifically, the goal of this evaluation is to determine whether, on the average, over a concentration range of 0.1 to 2 times the exposure limit, the method can provide a result that is within ± 25 percent of the true concentration 95 percent of the time. For simplification, the true concentration is assumed to be represented by an independent method. An experimental approach for collecting the data necessary for this determination is described below.

As part of the evaluation of a method, the sampling of a generated atmosphere is needed to more adequately assess the performance of a method. This allows the determination of 1) the capacity of the sampler; 2) the efficiency of analyte collection by the sampler; 3) the repeatability of the method; 4) the bias in the method; 5) interferences in the collection of the sample. Concentration ranges to be used in the evaluation of the method should be based on several factors. These ranges, at a minimum, should cover 0.1 to 2.0 times the exposure limit. In some instances, higher multiples of the exposure limit can be added if needed. In situations where multiple exposure limits exist for an analyte, the lowest exposure limit should be used to set the lower limit of the evaluation range and the highest limit used to calculate the upper limit of evaluation range 2 times the highest exposure limit). Intermediate evaluation concentrations should be within these exposure limits. The toxicity of an analyte may indicate that a concentration lower than that calculated by the exposure limit should be included in the measurement and evaluation ranges. Previous monitoring information from other methods may indicate that typical concentrations of the analyte may be below or above a concentration range based on the exposure limit. In this case, this lower or upper level may be included in the method evaluation.

Capacity of the Sampler and Sampling Rate

To determine the applicability of the sampling method, the capacity of the sampler should be determined as a function of flow rate and sampling time. This is particularly important if the analyte has a STEL and a time-weighted average.

Flow rates typical for the media selected should be used. These may range from 0.01–4 L/min, depending on sampler type. At extremely low flow rates (ca. 5 mL/min), the effect of diffusion of the analyte into the sampler must be considered. Flow rates should be kept at a high enough rate to prevent diffusion from having a positive bias in the sampler. Sampling should be performed at three different flow rates covering the range appropriate for the particular sampler type, unless the sampler is designed to operate at only one flow rate.

Sampling times should range from 22.5 min for STELs to 900 min (15 hours) for time-weighted averages. Shorter sampling times (e.g., 7.5 to 22.5 min) may be used for ceiling measurements. Flow rates should be based on accurately calibrated sampling pumps or critical orifices. The amount of analyte collected at the lowest flow rate and shortest sampling time should be greater than the limit of quantitation of the method. The generated concentration used for capacity determination should be at least 2 times the highest published exposure limit and verified by an independent method.

Sampling and Analysis Evaluation

To assess the performance of a method, certain additional experimental parameters should be evaluated through a series of defined experiments. The effect of environmental conditions on sampling efficiency of the sampling medium can be evaluated by a factorial design. The temperature, relative humidity, flow rate, and sampling times, determined in the experiment to have most severely limited sampler capacity, should be used in these experimental runs. At a minimum, the effect of concentration on method performance should be investigated. Three sets of 12 samples should be collected from an atmosphere containing concentrations of 0.1, 1.0, and 2.0 times the exposure limit at the humidity determined to have reduced sampler capacity for the maximum recommended sampling time determined in the preceding experiment.

If the analyte has a short-term or ceiling exposure limit in addition to a 8-hour time-weighted average, an additional 12 samplers should be collected at the STEL or C limit for the recommended sampling period at the appropriate flow rate. Potential interferences in the work environment should be included in the generation experiments to assess their impact on method performance. Concentrations up to 2 times the exposure limit value for the interference should be included. Other environmental factors may be studied, but will require a more comprehensive experimental design.

g. Discuss hazards and controls for beryllium in 10 CFR 850, “Chronic Beryllium Disease Prevention Program (CBDPP).”

The following is taken from DOE G 440.1-7A.

Title 10 CFR 850.11, “General CBDPP Requirements,” establishes CBDPP requirements. DOE’s acquisition regulation requires DOE/NNSA contractors to comply with applicable safety and health, public protection, and restoration of the environment

requirements in Federal rules. The CBDPP must specify the existing and planned operational tasks that are within the scope of the CBDPP.

The CBDPP must augment and, to the extent feasible, be integrated into the existing worker protection programs that cover activities at the facility. The detail, scope, and content of the CBDPP must be commensurate with the hazard of the activities performed. In all cases however, the CBDPP must include formal plans and measures for maintaining exposures to beryllium at or below the PEL and for complying with the medical, counseling, and recordkeeping provisions of 10 CFR 850 for workers with past exposure, or potential exposure, to beryllium at DOE/NNSA facilities. In addition, the CBDPP must satisfy each of the specific program requirements of subpart C of 10 CFR 850 and must contain provisions for

- minimizing the number of workers exposed and potentially exposed to beryllium;
- minimizing the number of opportunities for workers to be exposed to beryllium;
- minimizing the disability and lost work time of workers due to chronic beryllium disease (CBD), beryllium sensitization, and associated medical care; and
- setting specific exposure reduction and minimization goals that are appropriate for the beryllium activities covered by the CBDPP to further reduce exposure below the PEL.

Table 24 provides specific criteria for including elements in the CBDPP. As shown in the beryllium operations/locations column, certain CBDPP elements must be included regardless of the exposure level. Examples include baseline inventory, hazard assessment, and initial exposure monitoring. Other specific elements of the CBDPP must be included at exposure levels meeting or exceeding the action level. Examples include periodic monitoring, regulated areas, and hygiene facilities and practices. At exposure levels below the action level, less formality is required and sound judgment is essential in considering further reduction and minimization efforts.

Title 10 CFR 850.12, “Implementation,” requires employers to manage and control beryllium exposures in all activities consistent with the approved CBDPP plan. The rule prohibits:

- any DOE/NNSA or DOE/NNSA contractor employee from taking any action inconsistent with 10 CFR 850, an approved CBDPP, or any other Federal statute or regulation concerning beryllium exposures at DOE/NNSA facilities;
- the initiation of any task that is outside the scope of the CBDPP and that involves potential exposure to airborne beryllium until an updated CBDPP is approved by the head of the DOE/NNSA field element.

Employers must conduct sampling to determine the presence or absence of beryllium materials, surface contamination, or airborne particulates. A sampling and analysis plan may help in organizing and managing the survey. The amount of detail necessary in the plan will depend on the sampling strategy to be used and the size and complexity of the area to be covered. At a minimum, the plan should address the following:

- Where samples are to be taken, based on where beryllium was stored, transported, and used at the facility, as well as consideration of ventilation and airflow patterns and worker movement patterns
- How many samples are to be collected, based on the number of potential exposure locations

- How the samples will be collected and analyzed, including the air, surface, and bulk sampling methods
- Statistical methods that will be used to ensure confidence and representativeness of sample results
- The PPE and procedures that will be used to protect personnel performing sampling activities

Table 24. Levels at which the provisions of the CBDPP apply

Provision	Worker Exposure or Potential Exposure Levels [8-hr time-weighted average (TWA)]		
	Be Operations/ Locations ¹	≥ Action Level	> PEL (8-hr TWA)
Baseline Inventory (850.20)	X		
Hazard Assessment (850.21)	X		
Initial Exposure Monitoring (850.24)	X		
Periodic Exposure Monitoring (850.24)		X	
Exposure Reduction and Minimization (850.25)	X ²	X ³	X ⁴
Regulated Areas (850.26)		X	
Hygiene Facilities and Practices (850.27)		X	
Respiratory Protection (850.28)	X ⁵	X	
Protective Clothing and Equipment (850.29)	X ⁶	X	
Housekeeping (850.30)	X ⁷		
Release Criteria (850.31)	X ^{8,9}		
Medical Surveillance (850.34)	X ¹⁰		
Training and Counseling (850.37)	X ¹¹		
Warning Signs (850.38)		X	
<p>Wording in <i>italics</i> is different from the corresponding wording in the same table (Table 8, page 68863) of the rule's preamble in response to comments to improve accuracy and clarity.</p> <p>¹ Applies to beryllium operations and other locations <i>with</i> the potential for beryllium exposure.</p> <p>² <i>Employers</i> must implement actions for reducing and minimizing exposures, if practicable.</p> <p>³ <i>Employers</i> must establish a formal exposure reduction and minimization program, if practicable.</p> <p>⁴ <i>Employers</i> must reduce exposures to or below the <i>permissible exposure limit</i> (PEL).</p> <p>⁵ <i>Employers</i> must provide respirators when requested by the worker.</p> <p>⁶ <i>Employers</i> must provide protective clothing and equipment where surface contamination levels are above 3 µg/100 cm² and when requested by the worker.</p> <p>⁷ Housekeeping efforts must maintain removable surface contamination at or below 3 µg/100 cm² during non-operational hours.</p> <p>⁸ Removable contamination of equipment surfaces must not exceed 0.2 µg/100 cm² when released to the public or for non-beryllium use.</p> <p>⁹ Removable contamination of equipment surfaces must not exceed 3 µg/100 cm² when released to other beryllium handling facilities.</p> <p>¹⁰ <i>Employers</i> must provide medical surveillance for all beryllium-associated workers who voluntarily participate in the program.</p> <p>¹¹ Training is required for all workers who could be potentially exposed. <i>Counseling</i> must be offered to beryllium-associated workers diagnosed with <i>chronic beryllium disease</i> or beryllium sensitization.</p>			

Source: DOE G 440.1-7A

31. Occupational safety personnel must demonstrate a familiarity level knowledge of the use and function of worker protection safety testing and measurement equipment.

a. Discuss use, limitations, and function of worker protection safety testing equipment (e.g., oxygen meters, explosive atmosphere meters, electrical test equipment, illumination meters, and calipers).

The following is taken from OSHA Publications, Air Monitoring.

Direct-reading instruments provide information at the time of sampling, thus enabling rapid decision-making. Data obtained from direct-reading monitors can often be used to ensure proper selection of PPE, engineering controls, and work practices. The instruments can often provide the trained and experienced user the capability to determine if site personnel are potentially exposed to concentrations which exceed exposure limits or action levels for specific hazardous materials.

Direct-reading instruments were developed as early warning devices for use in industrial settings, where a leak or an accident could release a high concentration of a known chemical into the ambient atmosphere. Today, some direct-reading instruments can detect contaminants in concentrations down to one part contaminant per million parts (ppm) of air, although quantitative data are difficult to obtain when multiple contaminants are present. Unlike air sampling devices, which are used to collect samples for subsequent analysis in a laboratory, direct-reading instruments provide information at the time of sampling, enabling rapid decision-making.

Direct-reading instruments may be used to rapidly detect flammable or explosive atmospheres, oxygen deficiency, certain gases and vapors, and ionizing radiation. They are the primary tools of initial site characterization. The information provided by direct-reading instruments can be used to institute appropriate protective measures to determine the most appropriate equipment for further monitoring, and to develop optimum sampling and analytical protocols.

All direct-reading instruments have inherent constraints in their ability to detect hazards:

- They usually detect and/or measure only specific classes of chemicals.
- Generally, they are not designed to measure and/or detect airborne concentrations below 1 ppm.
- Many of the direct-reading instruments that have been designed to detect one particular substance also detect other substances (interference) and, consequently, may give false readings.

It is imperative that direct-reading instruments be operated, and their data interpreted, by qualified individuals who are thoroughly familiar with the particular device's operating principles and limitations and who have obtained the device's latest operating instructions and calibration curves. The following guidelines may facilitate accurate recording and interpretation:

- Calibrate instruments according to the manufacturer's instructions before and after every use.
- Develop chemical response curves if these are not provided by the instrument manufacturer.

- Remember that the instrument’s readings have limited value where contaminants are unknown. When recording readings of unknown contaminants, report them as “needle deflection” or “positive instrument response” rather than specific concentrations. Conduct additional monitoring at any location where a positive response occurs.
- A reading of zero should be reported as “no instrument response” rather than “clean” because quantities of chemicals may be present that are not detectable by the instrument.
- The survey should be repeated with several detection systems to maximize the number of chemicals detected.

Where appropriate, screening with direct-reading instruments for ionizing radiation should be conducted prior to and during site activities. Where appropriate, the type of radioactive isotopes present should also be identified to ensure that action levels, worker exposure and environmental standards are not exceeded.

b. Discuss the need for proper metering equipment maintenance and calibration.

The following is taken from DOE G 10 CFR 835/E1-Rev. 1.

The instrument shall be routinely tested during its use and periodically examined and tested to ensure that it maintains the required performance. This may require detailed testing or simple functional tests performed during routine calibrations. During use in the field, instruments shall be tested frequently with a check source to ensure that the readings remain within prescribed limits. Functional tests will also include battery checks and other field checks, as prescribed by the manufacturer or facility. Damaged or malfunctioning instruments should be promptly returned for maintenance.

Maintenance of portable survey instruments shall be provided and a program for preventive and corrective maintenance should be established and documented.

Instruments shall undergo calibration prior to use following any maintenance or any adjustment that voids the previous calibration.

The essential elements of an acceptable portable instrument calibration program include the following:

- An instrument calibration program that ensures that calibration is performed on each instrument at least annually
- A method to determine when instruments have been returned out-of-calibration and a method to notify users of out-of-calibration instruments
- A source-check system that permits monitoring of instrument performance in the field
- An instrument maintenance program that promptly identifies problems and ensures the proper repair and recalibration of instruments
- A full range of NIST-traceable radiation calibration sources that cover the types and intensities of radiation necessary for complete calibrations for the radiation fields encountered at the facility
- A QA and constancy check program for standard instruments that permits the facility to maintain the calibration of its reference fields

- An internal audit program shall be conducted no less frequently than every three years
- A records program shall be established that documents results of maintenance and calibration performed on instruments used for area monitoring and contamination control

Further, the following elements should be in place:

- Detailed procedures covering the calibration of reference sources, support instruments, and field instruments
- A record system that permits tracking of all calibration
- Properly trained staff with an adequate technical background in instrument calibration
- A dedicated facility that permits calibrations without outside physical interference

c. Describe circumstances requiring the use of each type of equipment.

Oxygen Meters

The following is taken from Buzzle.com, Oxygen Analyzer Features and Uses.

An oxygen analyzer (meter) is a device that measures the level of oxygen in a system therefore determining if the level needs to be increased or not. Oxygen analyzers in turn use a kind of oxygen sensor for their functioning. An analyzer uses a sensor cell constructed of ceramic materials to measure the oxygen level. Recently since industrial, vehicular, or rather all types of emissions are given more emphasis so as to decrease pollution, industrial users want the analyzers to be more accurate in the measurements and repeatable in terms of usage. Regular users of oxygen analyzers also want it to be more calibrated and in need of less maintenance. There are various types of oxygen analyzers and users have a wide range of choice from the following:

- Ambient temperature
- Electrochemical
- Paramagnetic
- Polarographic
- Zirconium oxide

The ambient temperature electrochemical sensor is also referred to as a galvanic sensor which is a small, partially sealed, cylindrical device that contains two dissimilar electrodes immersed in an electrolyte. The oxygen molecules diffuse in the electrolyte and that results in a chemical reaction that generates a certain amount of current that tells the level of oxygen in the system. Similarly a paramagnetic analyzer works on a simple principle that oxygen has a very high magnetic susceptibility and shows a paramagnetic behavior. Polarographic analyzers work well in case of percent measurement and the main advantage is when not operative, there is no consumption of the electrode. It can be stored for a longer duration of time.

Oxygen analyzers are used for combustion monitoring and keeping control over it in a range of applications helping industries achieve considerably in saving energy. The applications of oxygen analyzers vary from energy-consuming industries to various combustion facilities. They are used in industries such as iron and steel, electric power, oil and petrochemicals, ceramics, pulp and paper, food and textiles and in facilities such as incinerators and small or medium sized boilers. Monitoring and controlling the

analyzer also helps in lowering the amount of carbon dioxide, sulfur dioxide and nitrogen oxides in the emissions by resisting the incomplete combustion of fuel, therefore preventing the world from global warming and air pollution.

The following is taken from Denison University—Confined Space Plan

An oxygen meter can also be used to determine the oxygen concentration in the space atmosphere. Concentrations from 20.8 to 22.0 percent oxygen are considered acceptable for entering the space without wearing an air-supplied breathing device, provided other conditions are acceptable. If the oxygen concentration is outside the 20.8 to 22.0 percent range, do not enter the vessel without wearing an air supplied mask. Below 20.8 percent oxygen the danger is encountering hypoxia. Above 22.0 percent oxygen the danger is encountering the equivalent of hyperventilation.

Explosive Atmosphere Meter

The following is taken from Denison University—Confined Space Plan.

An explosion meter can be used to test a confined space's atmosphere for the presence of explosive vapors. If the meter indicates more than 0 percent, the source of the flammable vapor shall be identified and removed, if possible. If the flammable vapor source cannot be removed, personnel shall evaluate the degree of hazard and the need for additional precautions and then allow entry only after determining that work can proceed safely. In no case shall entry be permitted if the meter indicates as much as 25 percent of the lower explosive limit.

Electrical Test Equipment

The following is taken from the U.S. Department of Labor, Occupational Safety and Health Administration, OSHA Technical Manual, section II, chapter I, Personal Sampling for Air Contaminants.

The Gilian gilibrator shown in figure 17 is an electronic bubble flow meter, used to calibrate sampling pumps, that provides instantaneous air-flow readings and cumulative averaging of multiple measurements. These calibrators measure the flow rate and display the results as volume per unit of time and can be used to calibrate most air sampling pumps. The range with different cells is from 1 mL/min to 30 L/min.



Source: U.S. Department of Labor, Occupational Safety and Health Administration, OSHA Technical Manual

Figure 17. Gilian gilibrator

The Bios DryCal™ DC-Lite shown in figure 18 is an electronic dry-piston flow meter used to calibrate sampling pumps that provides immediate and average readings. The device can be used to calibrate either pressure (labeled inlet) or vacuum (labeled outlet) flow sources. The vacuum port is used to calibrate sampling pumps, and the pressure port is used to calibrate the outlet of sampling pumps used to fill gas sampling bags. The DC-Lite has a lead-acid battery and can be left on charge for an indefinite time without damaging the battery. Different models of the instrument cover an optimum flow range of 1 mL/min to 30 L/min.

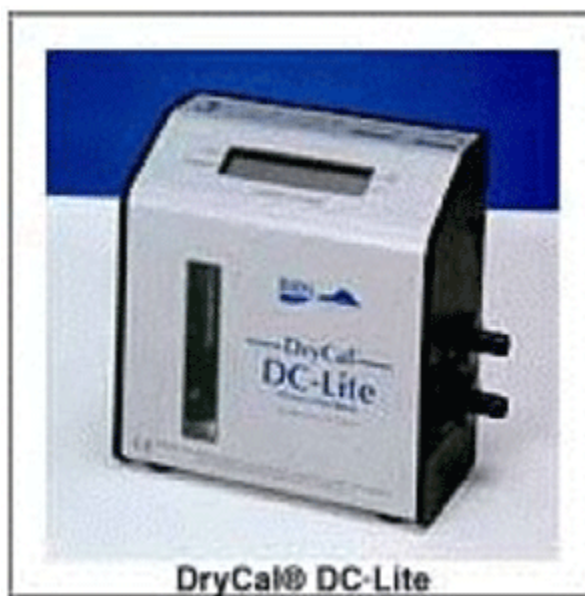

Source: U.S. Department of Labor, Occupational Safety and Health Administration, OSHA Technical Manual

Figure 18. Bios DryCal™ DC-Lite

The following is taken from the U.S. Department of Labor, Occupational Safety and Health Administration, OSHA Technical Manual, section II, chapter Technical Equipment: On-site Measurements.

Electrical testing meters include multimeters, clip-on current meters, megohmmeters, battery testers, ground-wire impedance testers, 120-V AC receptacle testers, ground-fault interrupt testers, electrostatic meters, and AC voltage detectors. Multimeters measure AC or DC voltage or current and resistance. They can check for AC leakage, proper line voltage, batteries, continuity, ground connection, integrity of shielded connections, fuses, etc. Other specialized equipment is described in Appendix II: 3-3.

Illumination Meters

The following is taken from Webster's Online Dictionary, Extended Definition—Light Meter.

Light meters or light detectors are also used in illumination. Their purpose is to measure the illumination level in the interior and to switch off or reduce the output level of luminaires. This can greatly reduce the energy burden of the building by significantly increasing the efficiency of its lighting system. It is known that 20 to 60 percent of all electrical power in a building is consumed by illumination. It is therefore recommended to use light meters in lighting systems, especially in rooms where one cannot expect users to pay attention to manually switching off the lights. Examples include hallways, stairs, and big halls.

There are, however, significant obstacles to overcome in order to achieve a successful implementation of light meters in lighting systems, of which user acceptance is by far the most formidable. Unexpected or too frequent switching and too bright or too dark rooms are very annoying and disturbing for users of the rooms. Therefore, different switching algorithms have been developed:

- Difference algorithm:
 - light switch is on lower light level then it switches off, thus taking care that the difference between the light level of the “on” state and “off” state is not too big
- Time delay algorithms:
 - Certain amount of time must pass since the last switch
 - Certain amount of time of sufficient illumination

d. Describe appropriate actions taken in response to various readings from each type of equipment.

Refer to 32c. for a discussion of the appropriate actions taken in response to various readings from each type of equipment.

e. Describe appropriate application and function of industrial hygiene monitoring and sampling equipment and discuss required safety interfaces.

The following is taken from SLAC National Accelerator Laboratory, ES&H, Industrial Hygiene.

Successful implementation of the IH program supports a safe and healthy work environment by

- anticipating, recognizing, and evaluating potential workplace hazards before they exist;
- implementing recommended engineering controls where feasible;
- implementing administrative controls when engineering controls are not feasible;
- surveying work areas to identify hazards and taking appropriate measures to reduce them;
- training personnel to recognize hazards and to take appropriate safety measures when working under potentially hazardous conditions;
- choosing the appropriate PPE; and
- determining which personnel should undergo medical surveillance based on their job classification and on occupational exposure surveys.

Industrial hygiene staff use approved exposure assessment strategies to characterize and monitor workers' potential exposures to chemical and physical hazards.

Industrial hygiene staff must perform baseline IH surveys and periodic resurveys of work areas and operations as needed to identify and evaluate potential worker health risks. Surveys often include some type of IH monitoring, such as air or wipe sampling, to measure the amount or concentration of the hazards.

Industrial hygiene staff will conduct risk-based qualitative reassessments of existing operations on a biannual basis, so that each work area will be re-evaluated at least once every two years.

Industrial hygiene monitoring takes place as a result of

- individuals or managers submitting a request
- chemical acquisition or design review processes
- regulatory requirements, policy, or agreements with the DOE

f. Demonstrate use of three metering instruments applicable to your duty functions.

This is a performance-based KSA. The Qualifying Official will evaluate its completion.

g. Explain how the instrument readings are translated into information describing the quality and adequacy of the related safety program(s) and effectiveness of the implemented controls.

The following is taken from SLAC National Accelerator Laboratory, ES&H, Industrial Hygiene.

After conducting an IH sampling event, the IH staff writes a detailed report that

- describes the tasks and locations where monitoring occurred
- identifies workers monitored or represented by the monitoring
- identifies sampling methods and durations
- describes control measures in place during monitoring
- notes any factors that may have affected sampling results
- provides an interpretation of the results

Photographs depicting the job setup and procedural steps at the time of the sampling may be included in the report, along with any recommendations to reduce potential or actual exposures in the future.

The IH staff e-mails the report to the supervisor of the area. The supervisor is responsible for distributing the report to affected personnel.

If an individual was the subject of personal monitoring, the IH staff also develops a notification of personal monitoring document and sends it to the affected person and supervisor along with the report within two weeks of the receipt of sample analysis. The notification of personal monitoring and IH report can be sent electronically or as a hard copy.

32. Occupational safety personnel must demonstrate a familiarity level knowledge of occupational medicine program and how it supports safety programs.

a. Describe how the following regulations and orders integrate occupational medicine into safety: 29 CFR 1910, 29 CFR 1926, 10 CFR 851, 10 CFR 850, 10 CFR 707, 10 CFR 712.

29 CFR 1910

The following is taken from 29 CFR 1910.120.

Employers engaged in operations specified in paragraphs (a)(1)(i) through (a)(1)(iv) of 29 CFR 1910.120 and not covered by (a)(2)(iii) exceptions and employers of employees specified in paragraph (q)(9) shall institute a medical surveillance program.

Employees covered. The medical surveillance program shall be instituted by the employer for the following employees:

- All employees who are or may be exposed to hazardous substances or health hazards at or above PELs or, if there is no PEL, above the published exposure levels for these substances, without regard to the use of respirators, for 30 days or more a year
- All employees who wear a respirator for 30 days or more a year or as required by 29 CFR. 1910.134
- All employees who are injured, become ill or develop signs or symptoms due to possible overexposure involving hazardous substances or health hazards from an emergency response or hazardous waste operation
- Members of HAZMAT teams

For employees who may have been injured, received a health impairment, developed signs or symptoms that may have resulted from exposure to hazardous substances resulting from an emergency incident, or exposed during an emergency incident to hazardous substances at concentrations above PELs or the published exposure levels without the necessary PPE being used, medical examinations and consultations shall be made available by the employer:

- as soon as possible following the emergency incident or development of signs or symptoms;
- at additional times, if the examining physician determines that follow-up examinations or consultations are medically necessary.

The following is taken from 29 CFR 1910.151.

The employer shall ensure the ready availability of medical personnel for advice and consultation on matters of plant health.

In the absence of an infirmary, clinic, or hospital in proximity to the workplace that is used for the treatment of all injured employees, a person or persons shall be adequately trained to render first aid. Adequate first-aid supplies shall be readily available.

Where the eyes or body of any person may be exposed to injurious corrosive materials, suitable facilities for quick drenching or flushing of the eyes and body shall be provided within the work area for immediate emergency use.

First-aid supplies are required to be readily available. An example of the minimal contents of a generic first-aid kit is described in ANSI Z308.1-1998, *Minimum Requirements for Workplace First-aid Kits*. The contents of the kit listed in the ANSI standard should be adequate for small worksites. When larger operations or multiple operations are being conducted at the same location, employers should determine the need for additional first-aid kits at the worksite, additional types of first-aid equipment and supplies and additional quantities and types of supplies and equipment in the first-aid kits.

In a similar fashion, employers who have unique or changing first-aid needs in their workplace may need to enhance their first-aid kits. The employer can use the OSHA 200 log, OSHA 101's or other reports to identify these unique problems. Consultation from the local fire/rescue department, appropriate medical professional, or local emergency room may be helpful to employers in these circumstances. By assessing the specific needs of their workplace, employers can ensure that reasonably anticipated supplies are available. Employers should assess the specific needs of their worksite periodically and augment the first-aid kit appropriately.

If it is reasonably anticipated that employees will be exposed to blood or other potentially infectious materials while using first-aid supplies, employers are required to provide appropriate PPE in compliance with the provisions of the occupational exposure to blood borne pathogens standard. This standard lists appropriate PPE for this type of exposure, such as gloves, gowns, face shields, masks, and eye protection

29 CFR 1926

The following is taken from 29 CFR 1926.50

The employer shall ensure the availability of medical personnel for advice and consultation on matters of occupational health.

Provisions shall be made prior to commencement of the project for prompt medical attention in case of serious injury.

In the absence of an infirmary, clinic, hospital, or physician that is reasonably accessible in terms of time and distance to the worksite available for the treatment of injured employees, a person who has a valid certificate in first-aid training from the U.S. Bureau

of Mines, the American Red Cross, or equivalent training that can be verified by documentary evidence, shall be available at the worksite to render first aid.

First-aid supplies shall be easily accessible when required.

The contents of the first-aid kit shall be placed in a weatherproof container with individual sealed packages for each type of item, and shall be checked by the employer before being sent out on each job and at least weekly on each job to ensure that the expended items are replaced.

Proper equipment for prompt transportation of the injured person to a physician or hospital, or a communication system for contacting necessary ambulance service, shall be provided.

In areas where 911 is not available, the telephone numbers of the physicians, hospitals, or ambulances shall be conspicuously posted.

The following is taken from 29 CFR 1926.803.

There shall be retained one or more licensed physicians familiar with and experienced in the physical requirements and the medical aspects of compressed air work and the treatment of decompression illness. He/she shall be available at all times while work is in progress to provide medical supervision of employees employed in compressed air work. He/she shall himself/herself be physically qualified and be willing to enter a pressurized environment.

No employee shall be permitted to enter a compressed air environment until he/she has been examined by the physician and reported by him/her to be physically qualified to engage in such work.

In the event an employee is absent from work for 10 days, or is absent due to sickness or injury, he/she shall not resume work until he/she is reexamined by the physician, and his/her physical condition reported to be such as to permit him/her to work in compressed air.

After an employee has been employed continuously in compressed air for a period designated by the physician, but not to exceed 1 year, he/she shall be reexamined by the physician to determine if he/she is still physically qualified to engage in compressed air work. Such physician shall at all times keep a complete and full record of examinations made by him/her. The physician shall also keep an accurate record of any decompression illness or other illness or injury incapacitating any employee for work, and of all loss of life that occurs in the operation of a tunnel, caisson, or other compartment in which compressed air is used.

Records shall be available for the inspection of the Secretary or his/her representatives, and a copy thereof shall be forwarded to OSHA within 48 hours following the occurrence of the accident, death, injury, or decompression illness. It shall state as fully as possible the cause of said death or decompression illness, and the place where the injured or sick employee was taken, and such other relative information as may be required by the Secretary.

A fully equipped first-aid station shall be provided at each tunnel project regardless of the number of persons employed. An ambulance or transportation suitable for a litter case shall be at each project.

Where tunnels are being excavated from portals more than 5 road miles apart, a first-aid station and transportation facilities shall be provided at each portal.

A medical lock shall be established and maintained in immediate working order whenever air pressure in the working chamber is increased above the normal atmosphere.

The medical lock shall

- have at least 6 feet of clear headroom at the center, and be subdivided into not less than two compartments;
- be readily accessible to employees working under compressed air;
- be kept ready for immediate use for at least 5 hours subsequent to the emergence of any employee from the working chamber;
- be properly heated, lighted and ventilated;
- be maintained in a sanitary condition;
- have a non-shatterable port through which the occupant(s) may be kept under constant observation;
- be designed for a working pressure of 75 psi;
- be equipped with internal controls that may be overridden by external controls;
- be provided with air pressure gauges to show the air pressure within each compartment to observers inside and outside the medical lock;
- be equipped with a manual type sprinkler system that can be activated inside the lock or by the outside lock tender;
- be provided with oxygen lines and fittings leading into external tanks. The lines shall be fitted with check valves to prevent reverse flow. The oxygen system inside the chamber shall be of a closed circuit design and be so designed as to automatically shut off the oxygen supply whenever the fire system is activated;
- be in constant charge of an attendant under the direct control of the retained physician. The attendant shall be trained in the use of the lock and suitably instructed regarding steps to be taken in the treatment of employees exhibiting symptoms compatible with a diagnosis of decompression illness;
- be adjacent to an adequate emergency medical facility;
- the medical facility shall be equipped with demand-type oxygen inhalation equipment approved by the U.S. Bureau of Mines;
- be capable of being maintained at a temperature, in use, not to exceed 90°F. nor be less than 70°F.; and
- be provided with sources of air, free of oil and carbon monoxide, for normal and emergency use, which are capable of raising the air pressure in the lock from 0 to 75 psig in 5 minutes.

10 CFR 851

The following is taken from 10 CFR 851, appendix A.

Contractors must establish and provide comprehensive occupational medicine services to workers employed at a covered work place who

- work on a DOE site for more than 30 days in a 12-month period; or

- are enrolled for any length of time in a medical or exposure monitoring program required by this rule and/or any other applicable Federal, state or local regulation, or other obligation.

The occupational medicine services must be under the direction of a graduate of a school of medicine or osteopathy who is licensed for the practice of medicine in the state in which the site is located.

Occupational medical physicians, occupational health nurses, physician's assistants, nurse practitioners, psychologists, employee assistance counselors, and other occupational health personnel providing occupational medicine services must be licensed, registered, or certified as required by Federal or state law where employed.

Contractors must provide the occupational medicine providers access to hazard information by promoting its communication, coordination, and sharing among operating and ES&H protection organizations.

Contractors must provide the occupational medicine providers with access to information on the following:

- Current information about actual or potential work-related site hazards
- Employee job-task and hazard analysis information, including essential job functions
- Actual or potential worksite exposures of each employee
- Personnel actions resulting in a change of job functions, hazards or exposures

Contractors must notify the occupational medicine providers when an employee has been absent because of an injury or illness for more than five consecutive workdays.

Contractors must provide the occupational medicine provider information on, and the opportunity to participate in, worker safety and health team meetings and committees.

Contractors must provide occupational medicine providers access to the workplace for evaluation of job conditions and issues relating to workers' health.

A designated occupational medicine provider must

- plan and implement the occupational medicine services; and
- participate in worker protection teams to build and maintain necessary partnerships among workers, their representatives, managers, and safety and health protection specialists in establishing and maintaining a safe and healthful workplace.

A record, containing any medical, health history, exposure history, and demographic data collected for the occupational medicine purposes, must be developed and maintained for each employee for whom medical services are provided. All occupational medical records must be maintained in accordance with EO 13335, "Incentives for the Use of Health Information Technology."

Employee medical, psychological, and employee assistance program records must be kept confidential, protected from unauthorized access, and stored under conditions that

ensure their long-term preservation. Psychological records must be maintained separately from medical records and in the custody of the designated psychologist.

Access to these records must be provided in accordance with DOE regulations implementing the Privacy Act and the Energy Employees Occupational Illness Compensation Program Act.

The occupational medicine services provider must determine the content of the worker health evaluations, which must be conducted under the direction of a licensed physician, in accordance with current sound and acceptable medical practices and all pertinent statutory and regulatory requirements, such as the Americans with Disabilities Act.

Workers must be informed of the purpose and nature of the medical evaluations and tests offered by the occupational medicine provider.

The purpose, nature, and results of evaluations and tests must be clearly communicated verbally and in writing to each worker provided testing.

The communication must be documented in the worker's medical record.

The occupational medicine provider must monitor ill and injured workers to facilitate their rehabilitation and safe return to work and to minimize lost time and its associated costs.

The occupational medicine provider must place an individual under medical restrictions when health evaluations indicate that the worker should not perform certain job tasks. The occupational medicine provider must notify the worker and contractor management when employee work restrictions are imposed or removed.

Occupational medicine provider physician and medical staff must, on a timely basis, communicate results of health evaluations to management and safety and health protection specialists to facilitate the mitigation of worksite hazards.

The occupational medicine provider must include measures to identify and manage the principal preventable causes of premature morbidity and mortality affecting worker health and productivity.

The contractor must include programs to prevent and manage these causes of morbidity when evaluations demonstrate their cost effectiveness.

Contractors must make available to the occupational medicine provider appropriate access to information from health, disability, and other insurance plans (de-identified as necessary) in order to facilitate this process.

The occupational medicine services provider must review and approve the medical and behavioral aspects of employee counseling and health promotional programs, including the following types:

- Contractor-sponsored or contractor-supported employee assistance programs
- Contractor-sponsored or contractor-supported alcohol and other substance abuse rehabilitation programs

- Contractor-sponsored or contractor-supported wellness programs

The occupational medicine services provider must review the medical aspects of immunization programs, blood-borne pathogens programs, and bio-hazardous waste programs to evaluate their conformance to applicable guidelines.

The occupational medicine services provider must develop and periodically review medical emergency response procedures included in site emergency and disaster preparedness plans. The medical emergency responses must be integrated with nearby community emergency and disaster plans.

10 CFR 850

The following is taken from 10 CFR 850.34.

The responsible employer must establish and implement a medical surveillance program for beryllium-associated workers who voluntarily participate in the program.

The responsible employer must designate a site occupational medical director (SOMD) who is responsible for administering the medical surveillance program.

The responsible employer must ensure that the medical evaluations and procedures required are performed by, or under the supervision of, a licensed physician who is familiar with the health effects of beryllium.

The responsible employer must establish, and maintain, a list of beryllium-associated workers who may be eligible for protective measures. The list must be

- based on the hazard assessment, exposure records, and other information regarding the identity of beryllium-associated workers; and
- adjusted at regular intervals based on periodic evaluations of beryllium-associated workers.

The responsible employer must provide the SOMD with the information needed to operate and administer the medical surveillance program, including the

- list of beryllium-associated workers;
- baseline inventory;
- hazard assessment and exposure monitoring data;
- identity and nature of activities or operations on the site that are covered under the CBDPP, related duties of beryllium-associated workers; and
- type of PPE used.

The responsible employer must provide the following information to the SOMD and the examining physician:

- A copy of this rule and its preamble
- A description of the worker's duties as they pertain to beryllium exposure
- Records of the worker's beryllium exposure
- A description of the personal protective and respiratory protective equipment used by the worker in the past, present, or anticipated future use

The responsible employer must provide, to beryllium-associated workers who voluntarily participate in the medical surveillance program, the medical evaluations and procedures at no cost and at a time and place that is reasonable and convenient to the worker.

The responsible employer must provide to beryllium-associated workers a chest radiograph every five years.

The responsible employer must provide a medical evaluation as soon as possible to any worker who may have been exposed to beryllium because of a beryllium emergency.

The responsible employer must establish a multiple physician review process for beryllium-associated workers that allows for the review of initial medical findings, determinations, or recommendations from any medical evaluation conducted pursuant to 10 CFR 850.

If the responsible employer selects the initial physician to conduct any medical examination or consultation provided to a beryllium-associated worker, the worker may designate a second physician to

- review any findings, determinations, or recommendations of the initial physician; and
- conduct such examinations, consultations and laboratory tests, as the second physician deems necessary to facilitate this review.

The responsible employer must promptly notify a beryllium-associated worker in writing of the right to seek a second medical opinion after the initial physician provided by the responsible employer conducts a medical examination or consultation.

The responsible employer may condition its participation in, and payment for, multiple physician review upon the beryllium-associated worker doing the following within fifteen days after receipt of the notice, or receipt of the initial physician's written opinion, whichever is later:

- Informing the responsible employer in writing that he or she intends to seek a second medical opinion
- Initiating steps to make an appointment with a second physician

If the findings, determinations, or recommendations of the second physician differ from those of the initial physician, then the responsible employer and the beryllium-associated worker must make efforts to encourage and assist the two physicians to resolve any disagreement.

If, despite the efforts of the responsible employer and the beryllium-associated worker, the two physicians are unable to resolve their disagreement, then the responsible employer and the worker, through their respective physicians, must designate a third physician to

- review any findings, determinations, or recommendations of the other two physicians; and
- conduct such examinations, consultations, laboratory tests, and consultations with the other two physicians, as the third physician deems necessary to resolve the disagreement among them.

The SOMD must act consistently with the findings, determinations, and recommendations of the third physician, unless the SOMD and the beryllium-associated worker reach an agreement that is consistent with the recommendations of at least one of the other two physicians.

The responsible employer and the beryllium-associated worker or the worker's designated representative may agree on the use of any alternate form of physician determination in lieu of the multiple physician review process so long as the alternative is expeditious and at least as protective of the worker.

Within two weeks of receipt of results, the SOMD must provide to the responsible employer a written, signed medical opinion for each medical evaluation performed on each beryllium-associated worker. The written opinion must take into account the findings, determinations, and recommendations of the other examining physicians who may have examined the beryllium-associated worker. The SOMD's opinion must contain

- the diagnosis of the worker's condition relevant to occupational exposure to beryllium, and any other medical condition that would place the worker at increased risk of material impairment to health from further exposure to beryllium;
- any recommendation for removal of the worker from DOE beryllium activities, or limitation on the worker's activities or duties or use of PPE, such as a respirator; and
- a statement that the SOMD or examining physician has clearly explained to the worker the results of the medical evaluation, including all tests results and any medical condition related to beryllium exposure that requires further evaluation or treatment.

The SOMD's written medical opinion must not reveal specific records, findings, and diagnoses that are not related to medical conditions that may be affected by beryllium exposure.

The SOMD must provide each beryllium-associated worker with a written medical opinion containing the results of all medical tests or procedures, an explanation of any abnormal findings, and any recommendation that the worker be referred for additional testing for evidence of CBD, within ten working days after the SOMD's receipt of the results of the medical tests or procedures.

The responsible employer must, within thirty days after a request by a beryllium-associated worker, provide the worker with the information the responsible employer is required to provide the examining physician.

The responsible employer must report on the applicable OSHA reporting form beryllium sensitization, CBD, or any other abnormal condition or disorder of workers caused or aggravated by occupational exposure to beryllium.

The responsible employer must routinely and systematically analyze medical, job, and exposure data with the aim of identifying individuals or groups of individuals potentially at risk for CBD and working conditions that are contributing to that risk.

The responsible employer must use the results of these analyses to identify additional workers to whom the responsible employer must provide medical surveillance and to determine the need for additional exposure controls.

10 CFR 707

The following is taken from 10 CFR 707.13.

All test results shall be submitted for medical review by the medical review officer (MRO). A confirmed positive test for drugs shall consist of an initial test performed by the immunoassay method, with positive results on that initial test confirmed by another test, performed by the gas chromatography/mass spectrometry method.

The MRO will consider the medical history of the employee or applicant, as well as any other relevant biomedical information. When there is a confirmed positive test result, the employee or applicant will be given an opportunity to report to the MRO the use of any prescription or over-the-counter medication. If the MRO determines that there is a legitimate medical explanation for a confirmed positive test result, consistent with legal and non-abusive drug use, the MRO will certify that the test results do not meet the conditions for a determination of use of illegal drugs. If no such certification can be made, the MRO will make a determination of use of illegal drugs.

10 CFR 712

Refer to 33e for a discussion of occupational medicine and physical requirements in a human reliability program (HRP).

b. Describe conduct and documentation requirements associated with surveillance physicals.

The following is taken from 10 CFR 850.

The responsible employer must provide to beryllium workers a medical evaluation annually, and to other beryllium-associated workers a medical evaluation every three years. The periodic medical evaluation must include the following:

- A detailed medical and work history with emphasis on past, present, and anticipated future exposure to beryllium
- A respiratory symptoms questionnaire
- A physical examination with emphasis on the respiratory system
- A Be-LPT
- Any other medical evaluations deemed appropriate by the examining physician for evaluating beryllium-related health effects

Medical examinations shall include a medical and work history with special emphasis on symptoms related to the handling of hazardous substances and health hazards, and to fitness for duty, including the ability to wear any required PPE under conditions that may be expected at the worksite.

The content of medical examinations or consultations made available to employees shall be determined by the attending physician. The guidelines in the Occupational Safety and Health Guidance Manual for Hazardous Waste Site Activities should be consulted.

All medical examinations and procedures shall be performed by or under the supervision of a licensed physician, preferably one knowledgeable in occupational medicine, and shall be provided without cost to the employee, without loss of pay, and at a reasonable time and place.

c. Describe fitness for duty and return to work practices and documentation.

The following is taken from 10 CFR 851, appendix A.

The following health evaluations must be conducted when determined necessary by the occupational medicine provider for the purpose of providing initial and continuing assessment of employee fitness for duty:

- At the time of employment entrance or transfer to a job with new functions and hazards, a medical placement evaluation of the individual's general health and physical and psychological capacity to perform work will establish a baseline record of physical condition and ensure fitness for duty.
- Periodic, hazard-based medical monitoring or qualification-based fitness for duty evaluations required by regulations and standards, or as recommended by the occupational medicine services provider, will be provided on the frequency required.
- Diagnostic examinations will evaluate employees' injuries and illnesses to determine work-relatedness, the applicability of medical restrictions, and referral for definitive care, as appropriate.
- After a work-related injury or illness or an absence due to any injury or illness lasting five or more consecutive workdays (or an equivalent time period for those individuals on an alternative work schedule), a return to work evaluation will determine the individual's physical and psychological capacity to perform work and return to duty.
- At the time of separation from employment, individuals shall be offered a general health evaluation to establish a record of physical condition.

d. Describe the purpose and conduct of routine pre- and separation/post-employment physicals.

The following is taken from 29 CFR 1910.120.

Medical examinations and consultations shall be made available by the employer to each employee covered under 29 CFR 1910.120 on the following schedules:

- Prior to assignment
- At least once every twelve months for each employee covered unless the attending physician believes a longer interval is appropriate
- At termination of employment or reassignment to an area where the employee would not be covered if the employee has not had an examination within the last six months
- As soon as possible upon notification by an employee that the employee has developed signs or symptoms indicating possible overexposure to hazardous substances or health hazards, or that the employee has been injured or exposed above the PELs or published exposure levels in an emergency situation
- At more frequent times, if the examining physician determines that an increased frequency of examination is medically necessary

e. List mandated physicals and its documentation, including human reliability, Department of Transportation, and firefighter physicals.

Human Reliability

The following is taken from 10 CFR 712.14.

The HRP medical assessment is performed to evaluate whether an HRP candidate or an HRP-certified individual

- represents a security concern
- has a condition that may prevent the individual from performing HRP duties in a reliable and safe manner

The medical assessment is performed initially on HRP candidates and individuals occupying HRP positions who have not yet received HRP certification. The medical assessment is performed annually for HRP-certified individuals, or more often as required by the SOMD.

The designated physician and other examiners working under the direction of the designated physician also will conduct an evaluation

- if an HRP-certified individual requests an evaluation
- if an HRP-certified individual is referred by management for an evaluation

The designated physician, under the supervision of the SOMD, is responsible for the medical assessment of HRP candidates and HRP-certified individuals. In performing this responsibility, the designated physician or the SOMD must integrate the medical evaluations, available testing results, psychological evaluations, any psychiatric evaluations, a review of current legal drug use, and any other relevant information. This information is used to determine if a reliability, safety, or security concern exists and if the individual is medically qualified for his or her assigned duties. If a security concern is identified, the designated physician or SOMD must immediately notify the HRP management official, who notifies the applicable DOE personnel security office and appropriate HRP certifying official.

The designated physician, with the assistance of the designated psychologist, must determine the existence or nature of any of the following:

- Physical or medical disabilities, such as a lack of visual acuity, defective color vision, impaired hearing, musculoskeletal deformities, and neuromuscular impairment
- Mental/personality disorders or behavioral problems, including alcohol and other substance use disorders, as described in the Diagnostic and Statistical Manual of Mental Disorders
- Use of illegal drugs or the abuse of legal drugs or other substances, as identified by self-reporting or by medical or psychological evaluation or testing
- Threat of suicide, homicide, or physical harm
- Medical conditions such as cardiovascular disease, endocrine disease, cerebrovascular or other neurologic disease, or the use of drugs for the treatment of conditions that may adversely affect the judgment or ability of an individual to perform assigned duties in a reliable and safe manner

Before the initial or annual medical assessment and psychological evaluation, employers must provide, to the designated physician and designated psychologist, a job task analysis for each HRP candidate or HRP-certified individual. Medical assessments and psychological evaluations may not be performed if a job task analysis has not been provided.

Psychological evaluations must be conducted

- for initial HRP certification. This psychological evaluation consists of a psychological assessment (test), approved by the Director, Office of Health and Safety or his or her designee, and a semi-structured interview.
- for recertification. This psychological evaluation consists of a semi-structured interview. A psychological assessment (test) may also be conducted as warranted.
- The medical assessment for recertification must include a psychological assessment (test) approved by the Director, Office of Health and Safety or his or her designee. This requirement can be implemented over a three-year period for individuals who are currently in an HRP position.
- when additional psychological or psychiatric evaluations are required by the SOMD to resolve any concerns.

HRP-certified individuals who have been on sick leave for five or more consecutive days, or an equivalent time period for those individuals on an alternative work schedule, must report in person to the designated physician, the designated psychologist, or the SOMD before being allowed to return to normal duties. The designated physician, the designated psychologist, or the SOMD must provide a written recommendation to the appropriate HRP supervisor regarding the individual's return to work. An HRP-certified individual also may be required to report to the designated physician, the designated psychologist, or the SOMD for written recommendation to return to normal duties after any period of sick leave.

The designated physician, the designated psychologist, or the SOMD may recommend temporary removal of an individual from an HRP position or restrictions on an individual's work in an HRP position if a medical condition or circumstance develops that affects the individual's ability to perform assigned job duties.

The designated physician, the designated psychologist, or the SOMD must immediately recommend medical removal or medical restrictions in writing to the appropriate HRP management official. If the HRP management official concurs, he or she will then notify the appropriate HRP certifying official. To reinstate or remove such restrictions, the designated physician, the designated psychologist, or the SOMD must make written recommendation to the HRP management official for concurrence. The HRP management official will then notify the appropriate HRP certifying official.

Individuals who request reinstatement in the HRP following rehabilitative treatment for alcohol use disorder, use of illegal drugs, or the abuse of legal drugs or other substances, must undergo an evaluation, as prescribed by the SOMD, to ensure continued rehabilitation

The HRP certifying official may reinstate HRP certification of an individual who successfully completes an SOMD-approved drug or alcohol rehabilitation program. Recertification is based on the SOMD's follow-up evaluation and recommendation. The

individual is also subject to unannounced follow-up tests for illegal drugs or alcohol and relevant counseling for three years.

HRP-certified individuals are required to immediately report to the designated physician, the designated psychologist, or the SOMD any physical or mental condition requiring medication or treatment. The designated physician, the designated psychologist, or the SOMD determines if temporary removal of the individual from HRP duties is required and follows the procedures.

Department of Transportation

The following is taken from 49 CFR 391.45.

A person shall not drive a commercial motor vehicle unless he/she is physically qualified to do so and, has on his/her person the original, or a photographic copy, of a medical examiner's certificate that he/she is physically qualified to drive a commercial motor vehicle.

A person is physically qualified to drive a motor vehicle if that person

- has no loss of a foot, a leg, a hand, or an arm, or has been granted a skill performance evaluation certificate;
- has no impairment of: a hand or finger that interferes with prehension or power grasping; or an arm, foot, or leg that interferes with the ability to perform normal tasks associated with operating a commercial motor vehicle; or any other significant limb defect or limitation that interferes with the ability to perform normal tasks associated with operating a commercial motor vehicle; or has been granted a skill performance evaluation certificate;
- has no established medical history or clinical diagnosis of diabetes mellitus currently requiring insulin for control;
- has no current clinical diagnosis of myocardial infarction, angina pectoris, coronary insufficiency, thrombosis, or any other cardiovascular disease of a variety known to be accompanied by syncope, dyspnea, collapse, or congestive cardiac failure;
- has no established medical history or clinical diagnosis of a respiratory dysfunction likely to interfere with his/her ability to control and drive a commercial motor vehicle safely;
- has no current clinical diagnosis of high blood pressure likely to interfere with his/her ability to operate a commercial motor vehicle safely;
- has no established medical history or clinical diagnosis of rheumatic, arthritic, orthopedic, muscular, neuromuscular, or vascular disease that interferes with his/her ability to control and operate a commercial motor vehicle safely;
- has no established medical history or clinical diagnosis of epilepsy or any other condition that is likely to cause loss of consciousness or any loss of ability to control a commercial motor vehicle;
- has no mental, nervous, organic, or functional disease or psychiatric disorder likely to interfere with his/her ability to drive a commercial motor vehicle safely;
- has distant visual acuity of at least 20/40 (Snellen) in each eye without corrective lenses or visual acuity separately corrected to 20/40 (Snellen) or better with corrective lenses, distant binocular acuity of at least 20/40 (Snellen) in both eyes with or without corrective lenses, field of vision of at least 70 degrees in the

horizontal meridian in each eye, and the ability to recognize the colors of traffic signals and devices showing standard red, green and amber;

- first perceives a forced whispered voice in the better ear not less than 5 feet with or without the use of a hearing aid, or, if tested by use of an audiometric device, does not have an average hearing loss in the better ear greater than 40 decibels at 500 Hz, 1,000 Hz and 2,000 Hz with or without a hearing device when the audiometric device is calibrated to the American National Standard Z24.5-1951;
- does not use a controlled substance, an amphetamine, a narcotic, or any other habit-forming drug; and
- has no current clinical diagnosis of alcoholism.

Firefighter

The following is taken from the National Fire Protection Association, NFPA 1582.

A medical evaluation of a candidate shall be conducted prior to the candidate being placed in training programs or fire department emergency response activities.

The medical evaluation of a candidate shall include a medical history, examination, and any laboratory tests required to detect physical or medical conditions that could adversely affect his/her ability to safely perform the essential job tasks.

Medical conditions that can affect a candidate's ability to safely perform essential job tasks shall be designated either category A or category B. Candidates with category A medical conditions shall not be certified as meeting the medical requirements of NFPA 1582. Candidates with category B medical conditions shall be certified as meeting the medical requirements of NFPA 1582 only if they can perform the essential job tasks without posing a significant safety and health risk to themselves, members, or civilians. Category A and B medical conditions are described in section 6.3 of NFPA 1582.

f. Explain how occupational medicine providers advise management on possible alternatives for less hazardous chemicals and process, and preparation for appropriate emergency care and treatment if hazards cannot be attenuated.

The following is taken from 29 CFR 1910.119.

When effective work practices and/or engineering controls are not feasible to achieve the PEL, or while such controls are being instituted, and in emergencies, appropriate respiratory equipment must be used. In addition, PPE such as gloves, safety goggles, helmets, safety shoes, and protective clothing may also be required. To be effective, PPE must be individually selected, properly fitted and periodically refitted; conscientiously and properly worn; regularly maintained; and replaced as necessary.

Alternative avenues of decreasing the risks associated with highly hazardous chemicals in workplaces is the reduction in the inventory of the highly hazardous chemical. This reduction in inventory will result in a reduction of the risk or potential for a catastrophic incident. Also, employers may be able to establish more efficient inventory control by reducing the quantities of highly hazardous chemicals onsite below the established threshold quantities. This reduction can be accomplished by ordering smaller shipments and maintaining the minimum inventory necessary for efficient and safe operation. When reduced inventory is not feasible, then the employer might consider dispersing inventory to several locations on site.

A PrHA is one of the most important elements of the process safety management (PSM) program. It provides information which will assist employers and employees in making decisions for improving safety and reducing the consequences of unwanted or unplanned releases of hazardous chemicals. The analysis is directed toward analyzing potential causes and consequences of fires, explosions, releases of toxic or flammable chemicals and major spills of hazardous chemicals. The evaluation focuses on equipment, instrumentation, utilities, human actions, and external factors that might impact the process.

Each employer must address what actions employees are to take when there is an unwanted release of highly hazardous chemicals. Emergency preparedness or the employer's tertiary lines of defense are those that will be relied on along with the secondary lines of defense when the primary lines of defense which are used to prevent an unwanted release fail to stop the release. Employers will need to decide if they want employees to handle and stop small or minor incidental releases; whether they wish to mobilize the available resources at the plant and have them brought to bear on a more significant release. It outlines whether employers want their employees to evacuate the danger area and promptly escape to a preplanned safe zone area, and allow the local community emergency response organizations to handle the release or whether the employer wants to use some combination of these actions. Employers will need to select how many different emergency preparedness or tertiary lines of defense they plan to have and then develop the necessary plans and procedures, and appropriately train employees in their emergency duties and responsibilities and then implement these lines of defense.

Employers at a minimum must have an emergency action plan that will facilitate the prompt evacuation of employees due to an unwanted release of a highly hazardous chemical. Preplanning for handling incidental releases for minor emergencies in the process area needs to be done, appropriate equipment for the hazards must be provided, and training conducted for those employees who will perform the emergency work before they respond to handle an actual release.

g. Discuss OSHA recordability determinations accomplished for OSHA record keeping.

The following is taken from 29 CFR 1904.7.

An injury or illness meets the general recording criteria, and is therefore recordable, if it results in any of the following: death, days away from work, restricted work or transfer to another job, medical treatment beyond first aid, or loss of consciousness. Also, a case meets the general recording criteria if it involves a significant injury or illness diagnosed by a physician or other licensed health care professional, even if it does not result in death, days away from work, restricted work or job transfer, medical treatment beyond first aid, or loss of consciousness.

h. Discuss workers' compensation program and medical documentation requirements.

The following is taken from the U.S. Department of Labor, Office of Worker's Compensation Program.

The Office of Workers' Compensation Programs (OWCP) administers four major disability compensation programs which provide wage replacement benefits, medical treatment, vocational rehabilitation, and other benefits to certain workers or their dependents who experience work-related injury or occupational disease.

These programs, the Energy Employees Occupational Illness Compensation Program, the Federal Employees' Compensation Program, the Longshore and Harbor Workers' Compensation Program, and the Coal Mine Workers' Compensation Program, serve the specific employee groups who are covered under the relevant statutes and regulations by mitigating the financial burden resulting from workplace injury.

In administering the programs, OWCP seeks to protect the interests of eligible workers, employers and the Federal government by ensuring timely and accurate claims adjudication and provision of benefits, by responsibly administering the funds authorized for this purpose, and by restoring injured workers to gainful work when permitted by the effects of the injury.

The following is taken from 20 CFR 10.115.

Evidence should be submitted in writing. The evidence submitted must be reliable, probative and substantial. Each claim for compensation must meet five requirements before OWCP can accept it. These requirements, which the employee must establish to meet his or her burden of proof, are as follows:

- The claim was filed within the time limits specified by FECA.
- The injured person was, at the time of injury, an employee of the United States.
- An injury, disease or death occurred.
- The injury, disease or death occurred while the employee was in the performance of duty.
- The medical condition for which compensation or medical benefits is claimed is causally related to the claimed injury, disease or death.

Neither the fact that the condition manifests itself during a period of Federal employment, nor the belief of the claimant that factors of employment caused or aggravated the condition, is sufficient in itself to establish causal relationship.

In all claims, the claimant is responsible for submitting, or arranging for submittal of, a medical report from the attending physician. For wage loss benefits, the claimant must also submit medical evidence showing that the condition claimed is disabling. The rules for submitting medical reports are found in 20 CFR 10.330 through 20 CFR 10.333.

The following is taken from 20 CFR 10.330.

In all cases reported to OWCP, a medical report from the attending physician is required. This report should include the following elements:

- Dates of examination and treatment
- History given by the employee
- Physical findings
- Results of diagnostic tests
- Diagnosis
- Course of treatment

- A description of any other conditions found but not due to the claimed injury
- The treatment given or recommended for the claimed injury
- The physician's opinion, with medical reasons, as to causal relationship between the diagnosed condition(s) and the factors or conditions of the employment
- The extent of disability affecting the employee's ability to work due to the injury
- The prognosis for recovery
- All other material findings

i. Describe purpose of travel physicals and pre-travel, and post travel counseling, "GO Kits" and post travel treatments if needed.

The following is taken from Center for Disease Control and Prevention, Yellow Book.

Travelers need to understand the health risks that traveling may pose and take an active part in health preparation. Travelers should find out as many details as possible about their travel destinations in order to tailor travel health advice individually.

Travelers should make certain there is enough time (ideally 4–6 weeks) to see a health-care provider and obtain any necessary vaccinations before they travel.

Travel medicine is based on the concept of the reduction of risk. Regardless of the perception and tolerance of risk, the hazards associated with travel cannot be eliminated, just as the risks of staying home are not zero. Even the act of trying to prevent a risk—such as the risk of yellow fever—can lead to a fatal reaction to the vaccine. Therefore, the goal in travel and in travel medicine should be the skillful management of risk, rather than trying to eliminate risk. The pre-travel physical and visit is an opportunity to discuss risks and develop plans that minimize the risks, based on evaluation of risks versus benefits. The goal of the pre-travel consultation is the effective and efficient preparation of travelers with the appropriate counseling, vaccinations, and medications to help reduce their risk of illness and injury during travel.

Pre-travel counseling and screening should assess risk factors that might indicate a need for a traveler to be referred to a mental health professional for evaluation, especially prior to travel that is likely to be stressful. Factors that should be assessed include

- pre-existing psychiatric diagnoses, such as depression or anxiety disorders;
- history of psychosis in the traveler or a close family member;
- history of suicide attempts;
- evidence of depressed mood at assessment;
- exposure to prior traumas, particularly prior to travel that could involve re-exposure to traumatic events or situations;
- recent major life stressors or emotional strain;
- use of medications that may have psychiatric or neurologic side effects; and
- pre-travel anxieties and phobias that are severe enough to interfere with a patient's ability to function or to prepare for and enjoy their travel.

Long-term travelers, aid workers, military personnel, and other travelers likely to be exposed to stressful situations should be advised that the stresses and challenges they may face, particularly if combined with long hours of work, lack of sleep, or fatigue, can contribute to stress and anxiety. Long-term travelers should be encouraged to

- learn how to recognize signs of stress, exhaustion, depression, and anxiety in themselves;
- take care of themselves physically by eating and exercising regularly; and
- use their full allotment of time off or annual leave, particularly if they recognize signs of stress or exhaustion in themselves.

Returning travelers may have experienced physical illnesses, personal difficulties, or traumas that could result in psychiatric reactions. Travel-related injuries and diseases that affect quality of life can also have profound and long-term psychiatric impacts. Even in the absence of trauma, some returning long-term travelers report experiencing “reverse culture shock” after their return, characterized by feelings of disorientation, unfamiliarity, and loss of confidence.

Post-travel evaluations should assess the following:

- Behavioral and psychiatric symptoms, including
 - experiences during or soon after travel, which have been painful, hard to reconcile or which still cause distress, anxiety, or avoidance
 - persistent sleep disturbance or unusual fatigue
 - excessive use of alcohol or drugs
- Behavioral or interpersonal difficulties in home, school, work, in friendships or relationships
- Somatic symptoms that can also be indications of distress, including
 - unexplained somatic symptoms, such as headaches, backaches, or abdominal pain; and somatic disorders such as fibromyalgia, chronic fatigue syndrome, temporomandibular disorder, and irritable bowel syndrome;
 - rashes, itching, and skin diseases, such as psoriasis, atopic dermatitis, and urticaria, which can be exacerbated by stress.

Clinicians should be aware that some travelers may be reluctant to acknowledge psychiatric symptoms or distress. For example, many cultures have stigmas associated with experiencing or disclosing behaviors associated with mental illness, as well as different culturally appropriate ways of expressing grief, pain, and loss. In addition, some travelers may fear being penalized or stigmatized at work if they have psychiatric diagnoses noted on their medical records.

Regardless of the type or duration of travel, and whether or not travelers appear to meet criteria for a psychiatric diagnosis, returned travelers who are having difficulties functioning or who appear to be unduly depressed or distressed should be encouraged to seek appropriate treatment or counseling.

The purpose of packing a travel health kit “Go Kit” is to ensure travelers have supplies they need to

- manage pre-existing medical conditions and treat any exacerbations of these conditions
- prevent illness related to traveling
- take care of minor health problems as they occur

Go kits are available commercially and may even be purchased over the Internet, however similar kits can be assembled at home, often at lower cost. The specific contents

are based on destination, duration of travel, type of travel, and the traveler's pre-existing medical conditions.

Basic items that should be considered are medications, items for basic first aid, a contact card, and other essentials such as insect repellent, sunscreen, and hand sanitizer/wipes.

An estimated 15–70 percent of international travelers returning to the United States have a travel-related illness. The likelihood of developing a medical condition during travel relates to an individual's past medical history, travel destination, duration of travel, level of accommodation, pre-travel immunization history, adherence to prescribed malaria chemoprophylaxis regimens, activities during travel, and especially to his or her history of exposure to infectious agents prior to and during travel.

Some illnesses that occur in returned travelers may begin during the travel period, others may occur weeks, months, or even years after return.

If you are injured during your trip or become ill after your trip, immediately consult your physician for treatment.

j. List appropriate immunizations for work with biological agents and for international travel.

The following is taken from Centers for Disease Control and Prevention, Antimicrobial Prophylaxis to Prevent Anthrax Among Decontamination/Cleanup Workers Responding to an Intentional Distribution of *Bacillus Anthracis* Biological Agents.

Decontamination/cleanup workers working in environments known to be contaminated with *Bacillus anthracis* spores may be at risk for inhalation anthrax. These workers should wear appropriate PPE and follow appropriate procedures, as outlined in other CDC guidance documents.

Despite appropriate PPE and procedures, however, there will remain a potential for breaches of protection and contamination of the workers. Furthermore, there is potential that such a breach or contamination will not be recognized at the time of occurrence. Finally, while it may be appropriate to conduct medical surveillance of cleanup workers for epidemiologic monitoring of the effectiveness of the protective measures, monitoring may not be reliable enough or timely enough to rely on for clinical decisions regarding the need for antimicrobial prophylaxis on an individual basis.

CDC recommends that decontamination/cleanup workers receive antimicrobial prophylaxis, using standard regimens starting in conjunction with or prior to the time of first entry into a contaminated location and continuing for 60 days after final opportunity for exposure.

The current recommended regimens (for adults) are as follows:

- Ciprofloxacin, 500 mg by mouth every 12 hours or
- Doxycycline, 100 mg by mouth every 12 hours

A medical protocol should be developed to implement prophylaxis, and this program should be under the supervision of an experienced physician. At a minimum, the protocol should include the following components: there should be a pre-deployment assessment,

including ascertainment of history of drug allergies, current medication that might interact adversely with the selected prophylactic antimicrobial, presence of any medical conditions that might contraindicate use of the selected antimicrobial, and education regarding potential side effects and how to report symptoms or problems. There should also be education regarding recognition of potential breaches in protection and regarding anthrax and its symptoms, emphasizing the need for prompt reporting of both breaches and symptoms. Provision should also be made for periodic re-assessment of workers receiving prophylaxis; this assessment should include both monitoring for evidence of side effects of medications and epidemiologic surveillance for evidence of exposures. There are no available data to guide selection of an appropriate interval for re-assessments, so as an interim guidance, this should be left to the professional judgment of the supervising physician. If workers develop adverse side effects during prophylaxis, alternative prophylactic antimicrobial therapies may be available and warranted.

The following is taken from Centers for Disease Control and Prevention, Vaccinations.

The CDC divides vaccines for travel into three categories: routine, recommended, and required.

Routine vaccines are necessary for protection from diseases that are still common in many parts of the world even though they rarely occur in the United States.

Recommended vaccines are recommended to protect travelers from illnesses present in other parts of the world and to prevent the importation of infectious diseases across international borders. Which vaccinations are needed depends on a number of factors including destination, if time will be spent in rural areas, the season of the year, age, health status, and previous immunizations.

The only vaccine required by international health regulations is yellow fever vaccination for travel to certain countries in sub-Saharan Africa and tropical South America. Meningococcal vaccination is required by the government of Saudi Arabia for annual travel during the Hajj.

k. Describe Employee Assistance Program (EAP).

The following is taken from DOE Employee Assistance Program.

The DOE's most important asset is its employees, and the agency is dedicated to maintaining a healthy and productive workforce. To that end, the headquarters employee assistance program (EAP) offers no-cost, confidential, short-term counseling and community resource referral for various issues affecting employee mental and emotional well-being such as stress, grief, depression/anxiety, family or financial problems, workplace conflict, and substance abuse. Staffed by experienced counselors, the EAP also works in a consultative role with managers and supervisors to help address workplace and organizational challenges and needs; and is active in helping organizations prevent and cope with workplace violence, trauma, and other emergency response situations.

Offered throughout the year, educational and wellness programs are held on a variety of topics; and EAP maintains lending libraries and informational resources at both sites.

I. Describe participation in and determination of duties in regards to 10 CFR 707, Workplace Substance Abuse Program.

The following is taken from 10 CFR 707.

In reviewing each proposed workplace substance abuse plan, DOE shall decide whether the program meets the applicable baseline requirements established by 10 CFR 707. The responsible DOE official will reject proposed workplace substance abuse plans that are deemed not to meet the baseline requirements. DOE shall provide the contractor with a written notification regarding the decision as to the acceptability of the plan. Nothing in this rule is intended to prohibit any contractor subject to this part from implementing workplace substance abuse requirements additional to those of the baseline, including drug testing employees and applicants for employment in any position and testing for any illegal drugs. However, the contractor shall inform DOE of such additional requirements at least thirty days prior to implementation.

DOE shall periodically review and evaluate each contractor's program, including the contractor's oversight of the covered subcontractors, to ensure effectiveness and compliance with 10 CFR 707.

Contractors or proposers will submit their program to DOE for review within thirty days of notification by DOE that the contract or proposed contract falls within the scope of 10 CFR 707. Workplace substance abuse programs shall be implemented within thirty days of approval by DOE. DOE may grant an extension to the notification or implementation period, as warranted by local conditions. Implementation may require changes to collective bargaining agreements.

To ensure consistency of application, DOE shall periodically review designated contracts and testing designated positions included in the workplace substance abuse plans approved by DOE. DOE will also periodically review implementation of programs conducted by prime contractors, to ensure consistency of application among prime contracts (and subcontracts where appropriate) throughout DOE.

33. Occupational safety personnel must demonstrate a working level knowledge of conduct of operations and familiarity with configuration management.

a. Complete a course or demonstrate equivalent learning in DOE O 422.1 Conduct of Operations.

This is a performance-based KSA. The Qualifying Official will evaluate its completion.

b. Explain how effective conduct of operations supports safety by comparing the CONOPS requirements to ISMS, 10 CFR 830, 10 CFR 851, and quality program principles.

The following is taken from DOE O 422.1.

Conduct of operations is one of the safety management programs recognized in the Nuclear Safety Rule but it also supports safety and mission success for a wide range of hazardous, complex, or mission-critical operations, and some conduct of operations attributes can enhance even routine operations. It supports the ISM system by providing concrete techniques and practices to implement the ISM core functions of develop and

implement hazard controls and perform work within controls. It may be implemented through facility policies, directives, plans, and safety management systems and need not be a stand-alone program.

c. Describe how implementing DOE-STD-1073-2003, DOE Standard: Configuration Management, contributes to process system safety.

The following is taken from 29 CFR 1910.119.

The employer shall establish and implement written procedures to manage changes to process chemicals, technology, equipment, and procedures; and, changes to facilities that affect a covered process.

The procedures shall ensure the following considerations are addressed prior to any change:

- The technical basis for the proposed change
- Impact of change on safety and health
- Modifications to operating procedures
- Necessary time period for the change
- Authorization requirements for the proposed change

Employees involved in operating a process and maintenance and contract employees whose job tasks will be affected by a change in the process shall be informed of, and trained in, the change prior to start-up of the process or affected part of the process.

If a change results in a change in the process safety information such information shall be updated accordingly. If a change results in a change in the operating procedures or practices such procedures or practices shall be updated accordingly.

d. Discuss conduct of maintenance (DOE O 433.1B) principles and Department of Energy requirements to ensure maintenance is performed in a safe and efficient manner.

The following is taken from DOE O 433.1B.

Federal and contractor organizations responsible for hazard category 1, 2, or 3 nuclear facilities must develop and implement a nuclear maintenance management program (NMMP) through tailored application. The NMMP must describe the safety management program for maintenance and the reliable performance of SSCs that are part of the safety basis at hazard category 1, 2 and 3 DOE nuclear facilities.

Federal and contractor organizations must conduct all maintenance of SSCs that are part of the safety basis in compliance with an approved NMMP.

Federal and contractor organizations must ensure that equivalencies and exemptions from the maintenance management program elements of this attachment are identified, formally documented with supporting justification, and approved.

Federal and contractor organizations must implement the NMMP through Federal or contractor-approved documents, respectively. This is normally accomplished with a manual or a set of implementing procedures.

Federal and contractor organizations must submit NMMP description documentation to DOE/NNSA for review and approval prior to the startup of new hazard category 1, 2, and 3 nuclear facilities and at least every three years for all nuclear facilities. NMMP description documentation must be, at a minimum, an applicability matrix or a combination of multiple documents. The following elements must be covered:

- Correlation of the requirements to the applicable facilities
- Correlation of the implementing documents to the specific requirements
- Documentation of the basis for applying a graded approach, if applicable

Federal and contractor organizations with previously approved maintenance management program documentation must submit either an addendum or page changes to the program documentation to reflect the changes made as a result of the implementation of requirements in this attachment. If no changes are needed, a memorandum to that effect may be submitted as the addendum. Changes must be submitted to DOE/NNSA for approval within 90 days from the date of inclusion of the requirements in this attachment in the contract.

Federal and contractor organizations must conduct assessments of NMMP implementation, at least every three years or less frequent if directed by the DOE/NNSA secretarial officer.

Federal and contractor organizations must ensure that NMMPs are identified in the applicable DSA.

Federal and contractor organizations must review proposed changes to the NMMP, which could affect the performance of safety SSCs, as part of the ongoing unreviewed safety question (USQ) process. This review is intended to evaluate whether safety SSCs are maintained and operated within the approved safety basis. Changes that would result in a positive USQ must be submitted to DOE/NNSA for approval prior to the change taking effect.

e. Describe concepts of process safety and explain how these reduce production and safety risks.

The following is taken from DOE-HDBK-1101-2004.

The PSM rule describes a comprehensive management system containing 14 elements for effective control of process hazards. The word system implies the integration of all management elements with a method for assessing the efficiency and effectiveness of implementation. The elements of the PSM rule are an interrelated set of management systems associated with the process, people, production, and preparedness, as shown in figure 19.

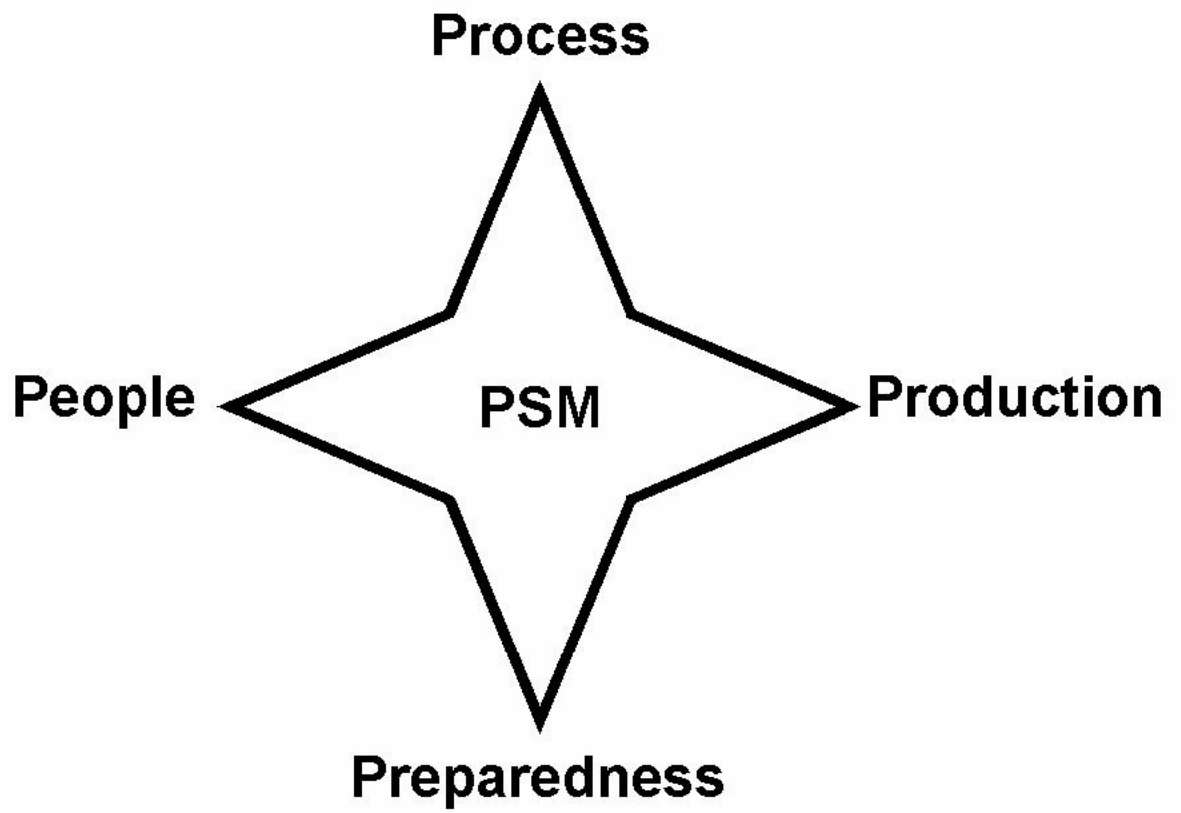

Source: DOE-HDBK-1101-2004.

Figure 19. The PSM system

Table 25 shows how the PSM elements are integrated in actual practice.

Table 25. PSM elements in actual practice

Employee participation	Ensure that workers and their representatives are consulted and have access to information regarding all PSM elements.
Process safety information	Maintain complete and accurate information on the process technology, process equipment, and hazardous characteristics and physical properties of all chemicals and intermediates for all covered processes.
Process hazard analysis	Identify and assess process hazards for each covered process, and take action to manage risk.
Operating procedures	Provide clear written instructions for safely conducting activities at each covered process that address operating limits, safety and health considerations, and safety systems and their functions.
Training	Provide initial and refresher training with a means of verifying employee understanding for all employees involved in operating a covered process.
Subcontractor safety	Ensure that subcontractor operations do not compromise the level of safety on or in the vicinity of a process using highly hazardous chemicals.
Pre-startup safety review	Perform safety reviews for new and modified facilities prior to operation when the modification is significant enough to require a change in the process safety information.
Mechanical integrity	Ensure the integrity and safe operation of process equipment through inspection, testing, preventive maintenance, and QA.
Non-routine work authorizations	Ensure that appropriate measures are taken any time non-routine operations are performed on or near covered process areas that might initiate or promote a release.
Management of change	Establish and implement written procedures to manage changes to process chemicals, technology, equipment, and procedure, and to facilities that affect a covered process.

Incident investigation	Using a written procedure, provide a team investigation of any incident which results in, or could reasonably result in, a catastrophic release of a highly hazardous chemical. Each investigation must be documented in a written report and findings and recommendations resolved in a timely manner.
Emergency planning and response	Establish and implement an emergency action plan for the entire plant that complies with 29 CFR 1910.38 and that also addresses small releases.
Compliance audit	Ensure that the PSM program is operating in an integrated and effective manner in compliance with PSM requirements.
Trade secrets	Ensure all information is available to support the PSM rule. When necessary, confidentiality or non-disclosure agreements may be used.

Source: DOE-HDBK-1101-2004

Mandatory Performance Activities

- f. Draft a safety program assessment plan that links CONOPS guidance with assessment criteria derived from regulatory and DOE directives for a safety functional area.**

This is a performance-based KSA. The Qualifying Official will evaluate its completion.

34. Occupational safety personnel must demonstrate a familiarity level knowledge of mechanical systems operations and methods of failure that create hazards.

- a. Describe valve terms, design, functioning, and safety considerations.**

The following is taken from DOE-HDBK-1018/2-93.

Disc

For a valve having a bonnet, the disc is the third primary principal pressure boundary. The disc provides the capability for permitting and prohibiting fluid flow. With the disc closed, full system pressure is applied across the disc if the outlet side is depressurized. For this reason, the disc is a pressure-retaining part. Discs are typically forged, and in some designs, hard-surfaced to provide good wear characteristics. A fine surface finish of the seating area of a disc is necessary for good sealing when the valve is closed. Most valves are named, in part, according to the design of their discs.

Seat/Backseat

The seat or seal rings provide the seating surface for the disc. In some designs, the body is machined to serve as the seating surface, and seal rings are not used. In other designs, forged seal rings are threaded or welded to the body to provide the seating surface. To improve the wear resistance of the seal rings, the surface is often hard faced by welding and then machining the contact surface of the seal ring. A fine surface finish of the

seating area is necessary for good sealing when the valve is closed. Seal rings are not usually considered pressure boundary parts because the body has sufficient wall thickness to withstand design pressure without relying upon the thickness of the seal rings.

Throttle

The term throttle indicates the ability to control flow. Some valves are specifically made to perform this task; other valves demonstrate poor characteristics in throttling or controlling flow in a valve.

Actuator

The actuator operates the stem and disk assembly. An actuator may be a manually operated hand wheel, manual lever, motor operator, solenoid operator, pneumatic operator, or hydraulic ram. In some designs, the actuator is supported by the bonnet. In other designs, a yoke mounted to the bonnet supports the actuator. Except for certain hydraulically controlled valves, actuators are outside of the pressure boundary. Yokes, when used, are always outside of the pressure boundary.

Bonnet

The cover for the opening in the valve body is the bonnet. In some designs, the body itself is split into two sections that bolt together. Like valve bodies, bonnets vary in design. Some bonnets function simply as valve covers, while others support valve internals and accessories such as the stem, disk, and actuator.

The bonnet is the second principal pressure boundary of a valve. It is cast or forged of the same material as the body and is connected to the body by a threaded, bolted, or welded joint. In all cases, the attachment of the bonnet to the body is considered a pressure boundary. This means that the weld joint or bolts that connect the bonnet to the body are pressure-retaining parts. Valve bonnets, although a necessity for most valves, represent a cause for concern. Bonnets can complicate the manufacture of valves, increase valve size, represent a significant cost portion of valve cost, and are a source for potential leakage.

Packing

Most valves use some form of packing to prevent leakage from the space between the stem and the bonnet. Packing is commonly a fibrous material (such as flax) or another compound (such as Teflon) that forms a seal between the internal parts of a valve and the outside where the stem extends through the body.

Valve packing must be properly compressed to prevent fluid loss and damage to the valve's stem. If a valve's packing is too loose, the valve will leak, which is a safety hazard. If the packing is too tight, it will impair the movement and possibly damage the stem.

Gate Valve

A gate valve is a linear motion valve used to start or stop fluid flow; however, it does not regulate or throttle flow. The name gate is derived from the appearance of the disk in the flow stream. Figure 20 illustrates a gate valve.

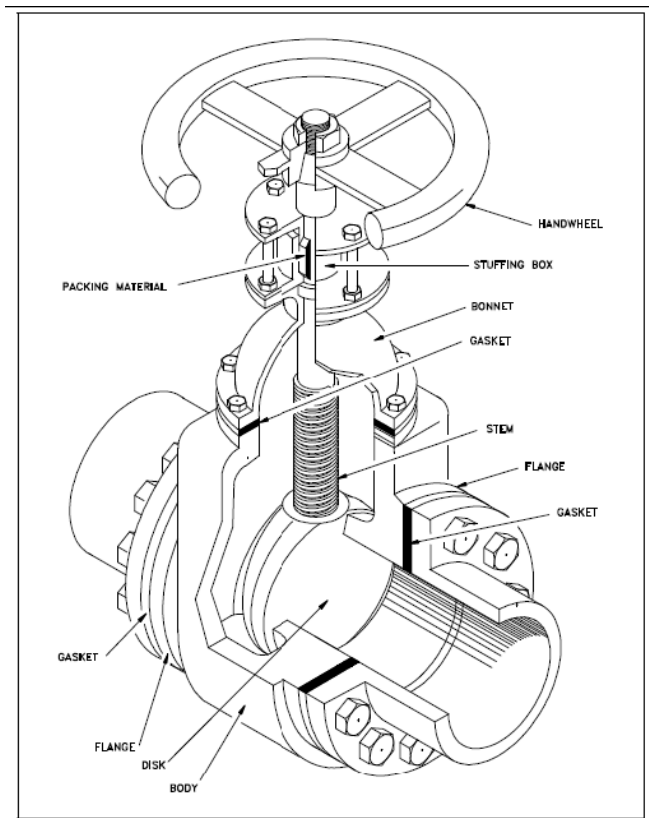

Source: DOE-HDBK-1018/2-93

Figure 20. Gate valve

The disk of a gate valve is completely removed from the flow stream when the valve is fully open. This characteristic offers virtually no resistance to flow when the valve is open. Hence, there is little pressure drop across an open gate valve. When the valve is fully closed, a disk-to-seal-ring contact surface exists for 360°, and good sealing is provided. With the proper mating of a disk to the seal ring, very little or no leakage occurs across the disk when the gate valve is closed.

Globe Valve

A globe valve is a linear motion valve used to stop, start, and regulate fluid flow. A Z-body globe valve is illustrated in figure 21.

As shown in figure 21, the globe valve disk can be totally removed from the flow path or it can completely close the flow path. The essential principle of globe valve operation is the perpendicular movement of the disk away from the seat. This causes the annular space between the disk and seat ring to gradually close as the valve is closed. This characteristic gives the globe valve good throttling ability, which permits its use in regulating flow.

Therefore, the globe valve may be used for both stopping and starting fluid flow and for regulating flow.

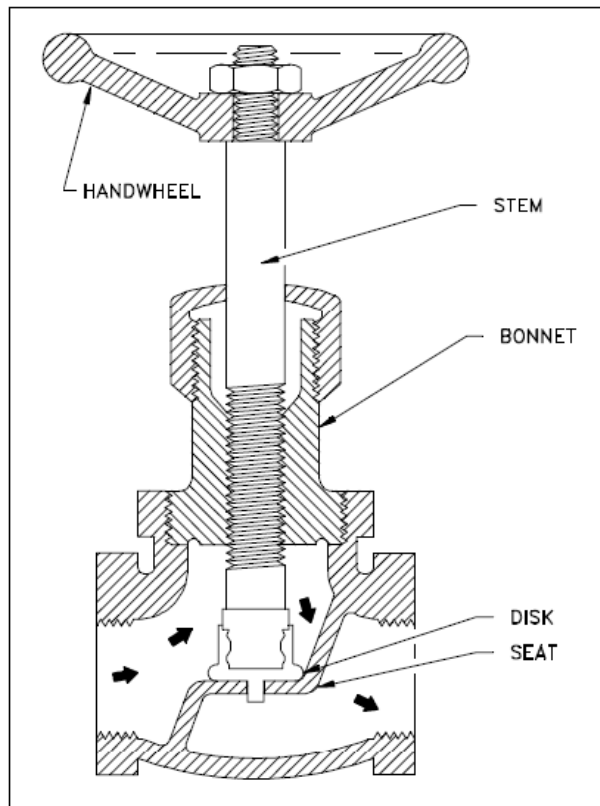

Source: DOE-HDBK-1018/2-93

Figure 21. Globe valve

When compared to a gate valve, a globe valve generally yields much less seat leakage. This is because the disk-to-seat ring contact is more at right angles, which permits the force of closing to tightly seat the disk.

Globe valves can be arranged so that the disk closes against or in the same direction of fluid flow. When the disk closes against the direction of flow, the kinetic energy of the fluid impedes closing but aids opening of the valve. When the disk closes in the same direction of flow, the kinetic energy of the fluid aids closing but impedes opening. This characteristic is preferable to other designs when quick-acting stop valves are necessary.

Globe valves also have drawbacks. The most evident shortcoming of the simple globe valve is the high head loss from two or more right angle turns of flowing fluid. Obstructions and discontinuities in the flow path lead to head loss. In a large high-pressure line, the fluid dynamic effects from pulsations, impacts, and pressure drops can damage trim, stem packing, and actuators. In addition, large valve sizes require considerable power to operate and are especially noisy in high-pressure applications.

Other drawbacks of globe valves are the large openings necessary for disk assembly, heavier weight than other valves of the same flow rating, and the cantilevered mounting of the disk to the stem.

Ball

A ball valve is a rotational motion valve that uses a ball-shaped disk to stop or start fluid flow. The ball, shown in figure 22, performs the same function as the disk in the globe valve. When the valve handle is turned to open the valve, the ball rotates to a point where the hole through the ball is in line with the valve body inlet and outlet. When the valve is shut, the ball is rotated so that the hole is perpendicular to the flow openings of the valve body and the flow is stopped.

Most ball valve actuators are of the quick-acting type, which require a 90° turn of the valve handle to operate the valve. Other ball valve actuators are planetary gear-operated. This type of gearing allows the use of a relatively small hand wheel and operating force to operate a fairly large valve.

Some ball valves have been developed with a spherical surface coated plug that is off to one side in the open position and rotates into the flow passage until it blocks the flow path completely.

Seating is accomplished by the eccentric movement of the plug. The valve requires no lubrication and can be used for throttling service.

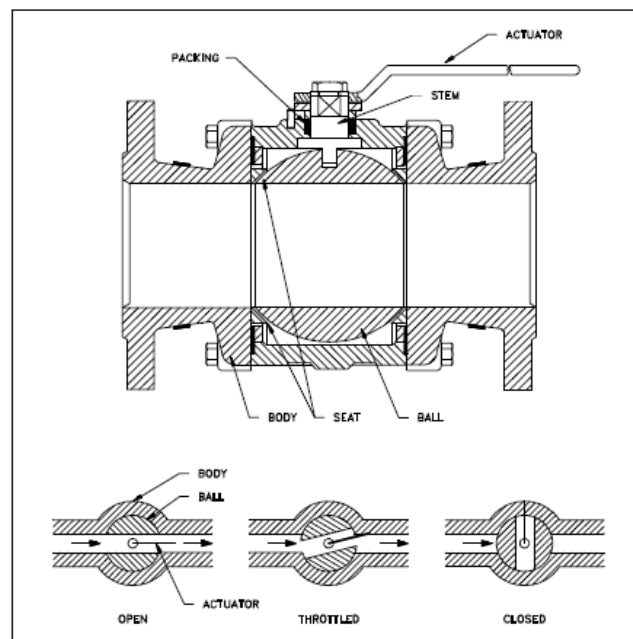

Source: DOE-hDBK-1018/2-93

Figure 22. Ball valve

Check Valve

Check valves are designed to prevent the reversal of flow in a piping system. These valves are activated by the flowing material in the pipeline. The pressure of the fluid passing through the system opens the valve, while any reversal of flow will close the valve. Closure is accomplished by the weight of the check mechanism, by back pressure, by a spring, or by a combination of these means. The general types of check valves are swing, tilting-disk, piston, butterfly, and stop.

A swing check valve is illustrated in figure 23. The valve allows full, unobstructed flow and automatically closes as pressure decreases. These valves are fully closed when the flow reaches zero and prevent back flow. Turbulence and pressure drop within the valve are very low.

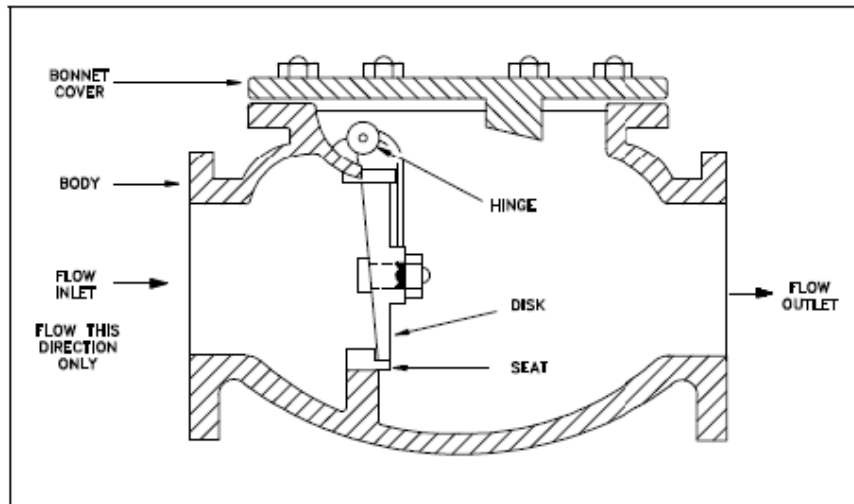

Source: DOE-HDBK-1018/2-93

Figure 23. Swing check valve

Butterfly Check Valve

Butterfly check valves have a seating arrangement similar to the seating arrangement of butterfly valves. Flow characteristics through these check valves are similar to the flow characteristics through butterfly valves. Consequently, butterfly check valves are quite frequently used in systems using butterfly valves. In addition, the construction of the butterfly check valve body is such that ample space is provided for unobstructed movement of the butterfly valve disk within the check valve body without the necessity of installing spacers.

The butterfly check valve design is based on a flexible sealing member against the bore of the valve body at an angle of 45°. The short distance the disk must move from full-open to full-closed inhibits the slamming action found in some other types of check valves. Figure 24 illustrates the internal assembly of the butterfly check valve.

Because the flow characteristics are similar to the flow characteristics of butterfly valves, applications of these valves are much the same. Also, because of their relatively quiet operation they find application in heating, ventilation, and air conditioning (HVAC) systems. Simplicity of design also permits their construction in large diameters—up to 72 inches.

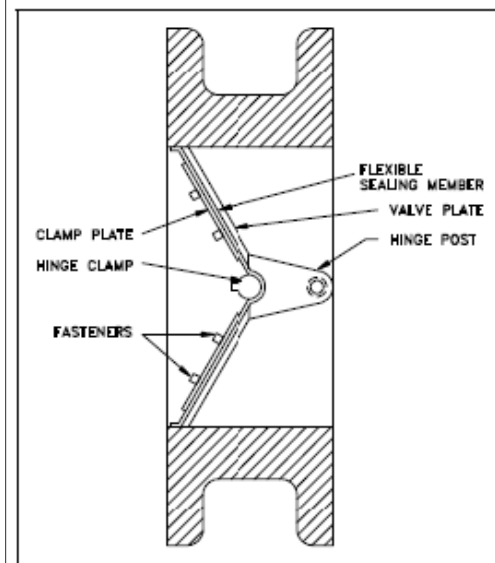

Source: DOE-HDBK-1018/2-93

Figure 24. Butterfly check valve

Regulation/Reducing Valves

Reducing valves automatically reduce supply pressure to a preselected pressure as long as the supply pressure is at least as high as the selected pressure. As illustrated in figure 25, the principal parts of the reducing valve are the main valve, an upward-seating valve that has a piston on top of its valve stem, an upward-seating auxiliary (or controlling) valve, a controlling diaphragm, and an adjusting spring and screw.

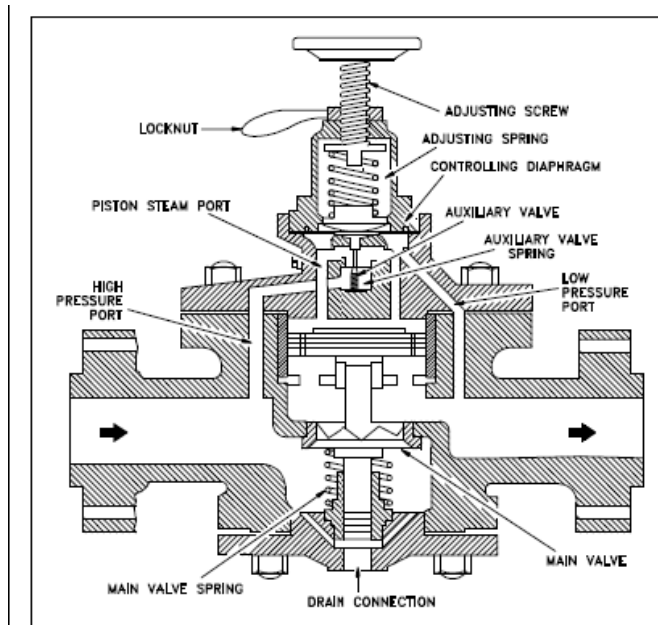

Source: DOE-HDBK-1018/2-93

Figure 25. Variable reducing valve

- b. Describe pump terms, design, functioning, and safety considerations.**
 - **Safety and pressure relief devices**
 - **Types of valve operators**
 - **Basic types of instrumentation**

Safety and Pressure Relief Devices

The following is taken from DOE-HDBK-1018/2-93.

Relief and safety valves prevent equipment damage by relieving accidental over-pressurization of fluid systems. The main difference between a relief valve and a safety valve is the extent of opening at the set-point pressure. A relief valve gradually opens as the inlet pressure increases above the set point. A relief valve opens only as necessary to relieve the over-pressure condition. A safety valve rapidly pops fully open as soon as the pressure setting is reached. A safety valve will stay fully open until the pressure drops below a reset pressure. The reset pressure is lower than the actuating pressure set point. The difference between the actuating pressure set point and the pressure at which the safety valve resets is called blowdown. Relief valves are typically used for incompressible fluids such as water or oil. Safety valves are typically used for compressible fluids such as steam or other gases. Most relief and safety valves open against the force of a compression spring. The pressure set point is adjusted by turning the adjusting nuts on top of the yoke to increase or decrease the spring compression.

Types of Valve Operators (Actuators)

The following is taken from DOE-HDBK-1018/2-93.

Valve actuators are selected based on a number of factors, including torque necessary to operate the valve and the need for automatic actuation. Types of actuators include manual hand wheel, manual lever, electrical motor, pneumatic, solenoid, hydraulic piston, and self-actuated. All actuators except manual hand wheel and lever are adaptable to automatic actuation.

Manual Actuator

Manual actuators are capable of placing the valve in any position but do not permit automatic operation. The most common type mechanical actuator is the handwheel. This type includes hand wheels fixed to the stem, hammer hand wheels, and hand wheels connected to the stem through gears.

Electric Actuator

Electric motors permit manual, semi-automatic, and automatic operation of the valve. Motors are used mostly for open-close functions, although they are adaptable to positioning the valve to any point opening as illustrated in figure 26. The motor is usually a reversible, high-speed type connected through a gear train to reduce the motor speed and thereby increase the torque at the stem. Direction of motor rotation determines direction of disk motion. The electrical actuation can be semi-automatic, as when the motor is started by a control system. A hand wheel, which can be engaged to the gear train, provides for manual operating of the valve.

Limit switches are normally provided to stop the motor automatically at full open and full closed valve positions. Limit switches are operated either physically by position of the valve or torsionally by torque of the motor.

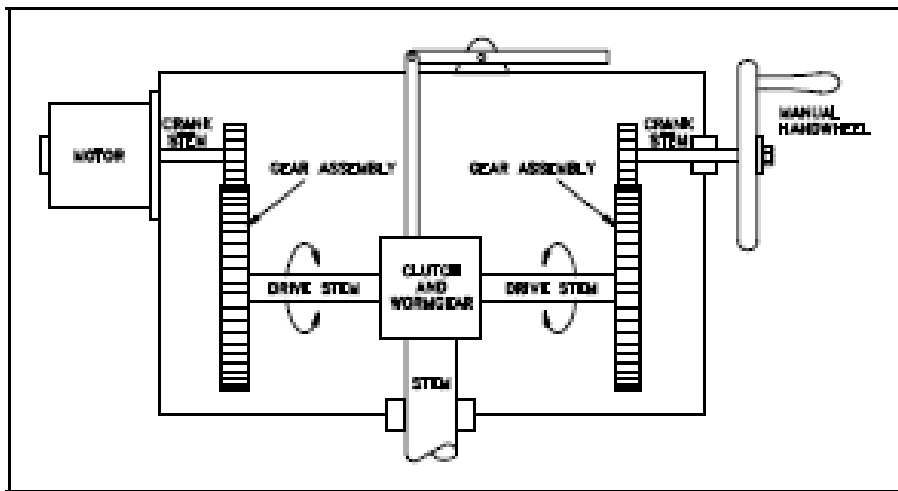

Source: DOE-HDBK-1018/2-93

Figure 26. Electric valve actuator

Pneumatic Actuator

Pneumatic actuators as illustrated in Figure 27 provide for automatic or semiautomatic valve operation. These actuators translate an air signal into valve stem motion by air pressure acting on a diaphragm or piston connected to the stem. Pneumatic actuators are used in throttle valves for open-close positioning where fast action is required. When air pressure closes the valve and spring action opens the valve, the actuator is termed directacting. When air pressure opens the valve and spring action closes the valve, the actuator is termed reverseacting.

Duplex actuators have air supplied to both sides of the diaphragm. The differential pressure across the diaphragm positions the valve stem. Automatic operation is provided when the air signals are automatically controlled by circuitry. Semi-automatic operation is provided by manual switches in the circuitry to the air control valves.

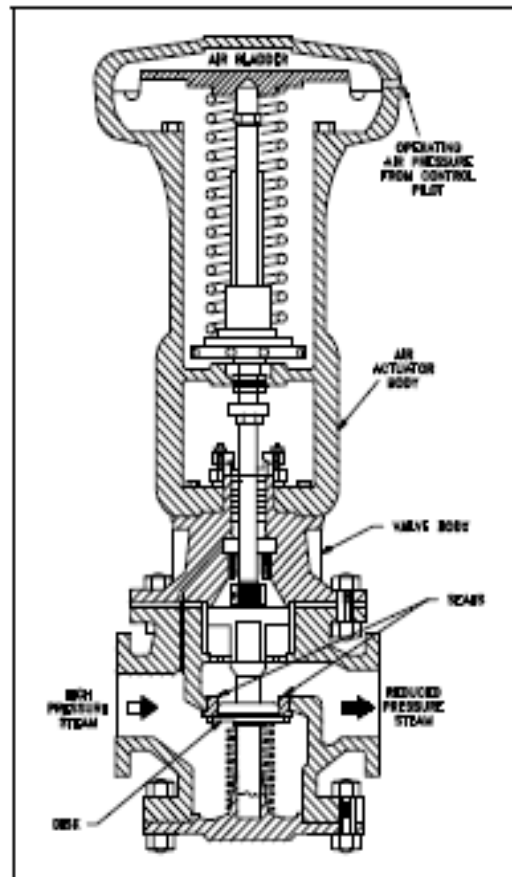

Source: DOE-HDBK-1018/2-93

Figure 27. Pneumatic actuator

Hydraulic Actuator

Hydraulic actuators provide for semi-automatic or automatic positioning of the valve, similar to the pneumatic actuators. These actuators use a piston to convert a signal pressure into valve stem motion. Hydraulic fluid is fed to either side of the piston while the other side is drained or bled. Water or oil is used as the hydraulic fluid. Solenoid valves are typically used for automatic control of the hydraulic fluid to direct either opening or closing of the valve. Manual valves can also be used for controlling the hydraulic fluid; thus providing semi-automatic operation.

Basic Types of Instrumentation

The following is taken from DOE-HDBK-1013/1-92.

Temperature Detectors

Although the temperatures that are monitored vary slightly depending on the details of facility design, temperature detectors are used to provide three basic functions: indication, alarm, and control. The temperatures monitored may normally be displayed in a central location, such as a control room, and may have audible and visual alarms associated with them when specified preset limits are exceeded. These temperatures may have control functions associated with them so that equipment is started or stopped to support a given temperature condition or so that a protective action occurs.

Pressure Detectors

Many processes are controlled by measuring pressure. Two basic types of pressure detectors are described here—bellows type and bourdon tube type.

The need for a pressure-sensing element that was extremely sensitive to low pressures and provided power for activating recording and indicating mechanisms resulted in the development of the metallic bellows pressure sensing element. The metallic bellows is most accurate when measuring pressures from 0.5 to 75 psig. However, when used in conjunction with a heavy range spring, some bellows can be used to measure pressures of over 1000 psig.

The bellows is a one-piece, collapsible, seamless metallic unit that has deep folds formed from very thin-walled tubing. The diameter of the bellows ranges from 0.5 to 12 in. and may have as many as 24 folds. System pressure is applied to the internal volume of the bellows. As the inlet pressure to the instrument varies, the bellows will expand or contract. The moving end of the bellows is connected to a mechanical linkage assembly. As the bellows and linkage assembly moves, either an electrical signal is generated or a direct pressure indication is provided. The flexibility of a metallic bellows is similar in character to that of a helical, coiled compression spring. Up to the elastic limit of the bellows, the relation between increments of load and deflection is linear. However, this relationship exists only when the bellows is under compression. It is necessary to construct the bellows such that all of the travel occurs on the compression side of the point of equilibrium. Therefore, in practice, the bellows must always be opposed by a spring, and the deflection characteristics will be the resulting force of the spring and bellows.

The bourdon tube pressure instrument is one of the oldest pressure-sensing instruments in use today. The bourdon tube consists of a thin-walled tube that is flattened diametrically

on opposite sides to produce a cross-sectional area elliptical in shape, having two long flat sides and two short round sides. The tube is bent lengthwise into an arc of a circle of 270 to 300 degrees. Pressure applied to the inside of the tube causes distention of the flat sections and tends to restore its original round cross-section. This change in cross-section causes the tube to straighten slightly. Since the tube is permanently fastened at one end, the tip of the tube traces a curve that is the result of the change in angular position with respect to the center. Within limits, the movement of the tip of the tube can then be used to position a pointer or to develop an equivalent electrical signal (which is discussed later in the text) to indicate the value of the applied internal pressure.

Level Detectors

Liquid level measuring devices are classified into two groups: direct method, and inferred method. An example of the direct method is the dipstick in a car that measures the height of the oil in the oil pan. An example of the inferred method is a pressure gauge at the bottom of a tank that measures the hydrostatic head pressure from the height of the liquid.

Flow Detectors

Flow measurement is an important process measurement to be considered in operating a facility's fluid systems. For efficient and economic operation of these fluid systems, flow measurement is necessary.

Head Flow Meters. Head flow meters operate on the principle of placing a restriction in the line to cause a differential pressure head. The differential pressure that is caused by the head, is measured and converted to a flow measurement. Industrial applications of head flow meters incorporate a pneumatic or electrical transmitting system for remote readout of flow rate. Generally, the indicating instrument extracts the square root of the differential pressure and displays the flow rate on a linear indicator.

Orifice Plate. The orifice plate is the simplest of the flow path restrictions used in flow detection, as well as the most economical. Orifice plates are flat plates 1/16 to 1/4 inch thick. They are normally mounted between a pair of flanges and are installed in a straight run of smooth pipe to avoid disturbance of flow patterns from fittings and valves.

Venturi Tube. The venturi tube is the most accurate flow-sensing element when properly calibrated. The venturi tube has a converging conical inlet, a cylindrical throat, and a diverging recovery cone. It has no projections into the fluid, no sharp corners, and no sudden changes in contour. The inlet section decreases the area of the fluid stream, causing the velocity to increase and the pressure to decrease. The low pressure is measured in the center of the cylindrical throat since the pressure will be at its lowest value, and neither the pressure nor the velocity is changing. The recovery cone allows for the recovery of pressure such that total pressure loss is only 10 to 25 percent. The high pressure is measured upstream of the entrance cone. The major disadvantages of this type of flow detection are the high initial costs for installation and difficulty in installation and inspection.

Dall Flow Tube. The dall flow tube has a higher ratio of pressure developed to pressure lost than the venturi flow tube. It is more compact and is commonly used in large flow applications. The tube consists of a short, straight inlet section followed by an abrupt decrease in the inside diameter of the tube. This section, called the inlet shoulder, is

followed by the converging inlet cone and a diverging exit cone. The two cones are separated by a slot or gap between the two cones. The low pressure is measured at the slotted throat (area between the two cones). The high pressure is measured at the upstream edge of the inlet shoulder.

Pitot Tube. The pitot tube is another primary flow element used to produce a differential pressure for flow detection. In its simplest form, it consists of a tube with an opening at the end. The small hole in the end is positioned such that it faces the flowing fluid. The velocity of the fluid at the opening of the tube decreases to zero. This provides for the high pressure input to a differential pressure detector. A pressure tap provides the low pressure input.

- c. **Discuss engineering prints and drawings and demonstrate the ability to read and interpret As-built drawings and Piping and Instrumentation Diagrams (P&ID).**
- d. **Using an engineering print, identify the symbols used in piping and instrumentation diagrams**
 - **How types of lines represent physical components**
 - **Title block information including notes, legend, revision block and drawing**
 - **Types of valves**
 - **Types of valve operators**
 - **Basic types of instrumentation and mechanical equipment**

Items c and d are performance-based KSAs. The Qualifying Official will evaluate their completion.

- e. **Identify how valve conditions are depicted and determine system flow path for a given valve lineup.**

Valve Conditions

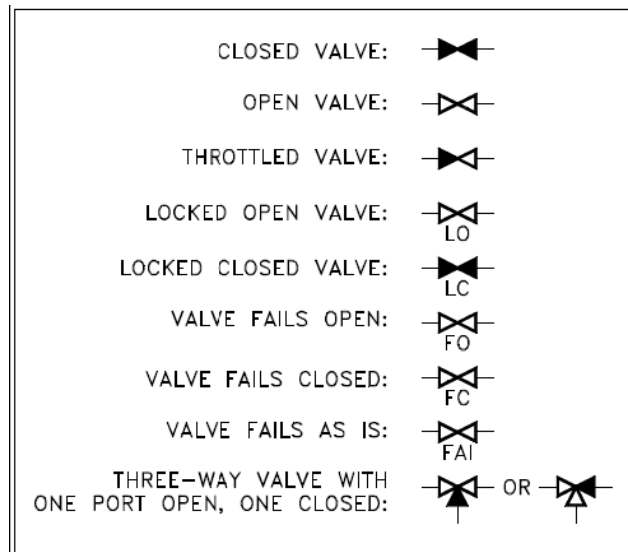

Source: DOE-HDBK-1016/1-93

Figure 28. Valve conditions

System Flow Path

This portion of the KSA is performance-based. The Qualifying Official will evaluate its completion.

f. Discuss the working of components, operations and theory of pneumatic systems.

The following is taken from *Improving Compressed Air System Performance: A Sourcebook for Industry*, U.S. Department of Energy, Energy Efficiency and Renewable Energy.

Compressed air is used widely throughout industry and is often considered the “fourth utility” at many facilities. Almost every industrial plant, from a small machine shop to an immense pulp and paper mill, has some type of compressed air system. In many cases, the compressed air system is so vital that the facility cannot operate without it. Plant air compressor systems can vary in size from a small unit of 5 horsepower (hp) to huge systems with more than 50,000 hp.

In many industrial facilities, air compressors use more electricity than any other type of equipment. Inefficiencies in compressed air systems can therefore be significant. Energy savings from system improvements can range from 20 percent to 50 percent or more of electricity consumption. For many facilities this is equivalent to thousands, or even hundreds of thousands of dollars of potential annual savings, depending on use. A properly managed compressed air system can save energy, reduce maintenance, decrease downtime, increase production throughput, and improve product quality.

Compressed air systems consist of a supply side, which includes compressors and air treatment, and a demand side, which includes distribution and storage systems and end-use equipment. A properly managed supply side will result in clean, dry, stable air being delivered at the appropriate pressure in a dependable, cost-effective manner. A properly managed demand side minimizes wasted air and uses compressed air for appropriate applications.

There are two basic compressor types: positive-displacement and dynamic. In a positive-displacement type, a given quantity of air or gas is trapped in a compression chamber and the volume which it occupies is mechanically reduced, causing a corresponding rise in pressure prior to discharge. At constant speed, the air flow remains essentially constant with variations in discharge pressure. Dynamic compressors impart velocity energy to continuously flowing air or gas by means of impellers rotating at very high speeds. The velocity energy is changed into pressure energy both by the impellers and the discharge volutes or diffusers. In the centrifugal-type dynamic compressors, the shape of the impeller blades determines the relationship between air flow and the pressure (or head) generated.

With a regulator positioned after a receiver tank, air from the receiver can expand (flow) through the valve to a point downstream. As pressure after the regulator rises, it is sensed in an internal pilot passage leading to the underside of the piston.

This piston has a large surface area exposed to downstream pressure and for this reason is quite sensitive to downstream pressure fluctuations. When downstream pressure nears the

preset level, the piston moves upward, pulling the poppet toward its seat. The poppet, once it seats, does not allow pressure to continue building downstream. In this way, a constant source of compressed air is made available to an actuator downstream.

g. Define the following terms as they relate to piping systems:

- **Pipe schedule**
- **Water hammer**
- **Hydrostatic test pressure**
- **Laminar flow**
- **Turbulent flow**

Pipe Schedule

The steel pipe data charts in ASME/ANSI B 36.10M-2004, *Welded and Seamless Wrought Steel Pipe*, and ASME/ANSI B36.19 2004, *Stainless Steel Pipe*, can be used to find pipe sizes, diameters, wall thickness, working pressures, and more.

Regardless of schedule number, pipes of a particular size all have the same outside diameter (notwithstanding manufacturing tolerances). As the schedule number increases, the wall thickness increases, and the actual bore is reduced. For example

- a 4-inch schedule 40 pipe has an outside diameter of 4.500 inches, a wall thickness of 0.237 inches, giving a bore of 4.026 inches;
- a 4-inch schedule 80 pipe has an outside diameter of 4.500 inches, a wall thickness of 0.337 inches, giving a bore of 3.826 inches.

Water Hammer

The following is taken from DOE-HDBK-1012/3-92.

Water hammer is a liquid shock wave resulting from the sudden starting or stopping of flow. It is affected by the initial system pressure, the density of the fluid, the speed of sound in the fluid, the elasticity of the fluid and pipe, the change in velocity of the fluid, the diameter and thickness of the pipe, and the valve operating time.

During the closing of a valve, kinetic energy of the moving fluid is converted into potential energy. Elasticity of the fluid and pipe wall produces a wave of positive pressure back toward the fluid's source. When this wave reaches the source, the mass of fluid will be at rest, but under tremendous pressure. The compressed liquid and stretched pipe walls will now start to release the liquid in the pipe back to the source and return to the static pressure of the source. This release of energy will form another pressure wave back to the valve. When this shock wave reaches the valve, due to the momentum of the fluid, the pipe wall will begin to contract. This contraction is transmitted back to the source, which places the pressure in the piping below that of the static pressure of the source. These pressure waves will travel back and forth several times until the fluid friction dampens the alternating pressure waves to the static pressure of the source. Normally, the entire hammer process takes place in under one second.

The initial shock of suddenly stopped flow can induce transient pressure changes that exceed the static pressure. If the valve is closed slowly, the loss of kinetic energy is gradual. If it is closed quickly, the loss of kinetic energy is very rapid. A shock wave results because of this rapid loss of kinetic energy. The shock wave caused by water hammer can be of sufficient magnitude to cause physical damage to piping, equipment,

and personnel. Water hammer in pipes has been known to pull pipe supports from their mounts, rupture piping, and cause pipe whip.

Hydrostatic Test Pressure

The following is taken from Los Alamos National Laboratory (LANL), *Engineering Standards Manual*, OST220-03-01-ESM.

The minimum hydrostatic test pressure for metallic piping shall be per the following equation.

$$P_T = 1.5 \times P_D \times \frac{SD}{ST}$$

where

P_T = minimum test gage pressure

P_D = internal design gage pressure

ST = allowable stress value at test temperature

SD = allowable stress value at design temperature.

Note: The maximum allowable value of $\frac{SD}{ST}$ is 6.5.

When a maximum test pressure is specified, the test pressure shall not exceed this amount.

When no maximum test pressure is specified, the test shall not be greater than 110% of the minimum.

When using water, static head due to differences in the elevation of the top of the piping system and the elevation of the test gage shall be accounted for in pressuring the piping system to be tested by the following equations:

$$SH \text{ (psi)} = (HE - GE) \times 0.433$$

$$PST = PT + SH$$

where

HE = high point elevation (ft)

GE = gage point elevation (ft)

SH = static head (psi)

PST = minimum test gage pressure corrected for static head

0.433 = conversion factor (ft of water to psi).

Pressure gages should be connected directly to the piping. Calibrated pressure gages shall be used in all code testing. Pressure gage range should exceed the intended test pressure by approximately double but in no case should the range be less than one and one-half (1½) times the test pressure.

The following definitions are taken from DOE-HDBK-1012/3-92.

Laminar Flow

Laminar flow is also referred to as streamline or viscous flow. These terms are descriptive of the flow because in laminar flow 1) layers of water flow over one another at different speeds with virtually no mixing between layers, 2) fluid particles move in definite and observable paths or streamlines, and 3) the flow is characteristic of viscous (thick) fluid or is one in which viscosity of the fluid plays a significant part.

Turbulent Flow

Turbulent flow is characterized by the irregular movement of particles of the fluid. There is no definite frequency as there is in wave motion. The particles travel in irregular paths with no observable pattern and no definite layers.

h. Discuss the hazards of incompatible materials, corrosion, and inadequate design.

The following is taken from TheFabricator.com

Incompatible Materials

Certain metal combinations cannot be joined successfully with fusion welding. Deciding how to join them requires examining options, including potential material substitutions and process possibilities.

Some material combinations will not stick together, no matter which procedure is used. When confronted with this situation, stop and consider the problem.

Most problems with welding incompatible materials are generated by fusion welding, because the combined metallurgy of each of the original materials prevents the production of sound joints.

Unsound joints result when there is a great difference between the melting temperatures of the two materials; when there is no appreciable solubility of either metal in the other in the solid state; and when brittle intermetallic compounds are likely to form.

Stresses can develop in the weld when there are big differences between the thermal expansion coefficients, thermal conductivity, and specific heat of the two materials.

If two or more materials, or chemicals, remain in contact indefinitely without reaction, they are compatible. If two or more materials in contact begin to react immediately, or even over a period of months or years, they are incompatible.

The following is taken from ProcessOperations.com, Chemical Incompatibility Hazards.

Chemical compatibility is not only of concern for the storage of the chemicals, but also for the disposal of unused or waste materials containing chemicals.

Accidents have occurred when mixing incompatible chemicals in disposal containers.

Bulging or corrosion of containers is a frequent early warning sign of hazardous incompatibility. Containers can become overheated, pressurized and ruptured. Other signs include temperature changes (e.g., temperature rise due to exothermic reaction), color or viscosity change, formation of vapors, toxic gases (such as when acid mixed with

cyanide produces hydrogen cyanide gas), foam, or sludges or crystals (e.g., organic peroxides). The formation of crystals on containers, especially around openings, should be treated with great caution. Some of these crystals are shock-sensitive, and can lead to fire or explosion.

Table 26 provides examples of hazards caused by incompatible materials.

Table 26. Examples of incompatible materials

HAZARD	EXAMPLE OF INCOMPATIBILITY
Heat generation	Acid and water
Fire and explosion	Hydrogen sulfide and calcium hypochlorite; dusts in air
Toxic gas or vapor production	Sulfuric acid and aluminum
Flammable gas or vapor production	Acids and metals
Formation of substance with greater toxicity than the reactants (separately)	Chlorine and ammonia
Formation of shock or friction-sensitive compounds	Peroxides and organics or liquid oxygen and petroleum products
Solubilization of toxic substance	Hydrochloric acid and chromium
Dispersal of toxic dusts and mists	Sodium or potassium cyanide and water or acid vapor
Violent polymerization and heat release	Ammonia and acrylonitrile

Source: Chemical Incompatibility Hazards

Corrosion

The following is taken from DOE-HDBK-1015/1-93.

Corrosion is the deterioration of a material due to interaction with its environment. Corrosion can have many forms, both wet and dry. The surface of a metal undergoes a slow, relatively uniform removal of material. This occurs on the surface of a single metal rather than dissimilar metals. In general corrosion, a nearly infinite number of micro-cells are established on the metal surface. Oxidation occurs at anodic areas and reduction at cathodic areas. The micro-cells are uniformly distributed over the metallic surface, and as the reaction proceeds the cells may migrate, or disappear and re-form. That is, any particular micro-region may be alternately anodic and cathodic. The result is a uniform attack on the metal surface.

Pitting and crevice corrosion are a major hazard. Pitting corrosion is a hazard due to the possible rapid penetration of the metal with little overall loss of mass. Stress corrosion cracking is a great concern due to the hazard that it can readily crack metal of appreciable thickness. The crack can lead to a serious failure of the component, or system.

Inadequate Design

The consequences of design error must be considered in the hazard analysis process. As experience has shown, design error can take many forms, including the use of improper standards, misinterpreting standards, failure of the review process to uncover flaws, improper models, and poor design oversight.

On August 1, 2007, approximately 1000 feet of the deck truss on the eight-lane I-35W Bridge over the Mississippi River in Minneapolis, Minnesota, collapsed. Much of the section of collapsed bridge fell into the river and, as a result, 13 people died and 145 were injured. The National Transportation Safety Board (NTSB) investigation determined that the probable cause of the bridge collapse was inadequate load capacity of the gusset plates due to a design error. Increases in the weight of the bridge contributed to the accident. The weight increase was a result of bridge modifications, heavy traffic, and concentrated construction loads on the bridge on the day of the collapse. The NTSB also identified a number of design process failures, including insufficient quality control procedures for designing bridges, insufficient Federal and state government procedures for reviewing and approving bridge designs and calculations, lack of guidance for placement of construction loads on bridges, lack of inspection guidance for conditions of gusset plate distortion, and inadequate use of technologies for accurately assessing the condition of gusset plates on deck truss bridges.

i. Discuss theory and operation of heating, ventilation, and air conditioning (HVAC) systems, including glove boxes and fume hoods.

The following is taken from Hvachome. What is HVAC?

The primary use of HVAC is to regulate room temperature, humidity, and air flow, ensuring that such elements remain within their acceptable ranges. Effective control of such factors minimizes health-related risks. A very humid atmosphere impairs the body's ability to regulate body temperature as it prevents the evaporation of sweat. High humidity also decreases physical strength, which usually leads to fatigue. An unhealthy surrounding can also affect people's thinking abilities. Hypothermia, heat stroke, and hyperpyrexia, among others, are some of the illnesses that may also occur.

Three Functions of HVAC

Heating is significant in maintaining adequate room temperature especially during colder weather conditions. There are two classifications of heating: local and central. The latter is more commonly used because it is more economical. Furnace or boiler, heat pump, and radiator make up the heating system.

Ventilation, on the other hand, is associated with air movement. There are many types of ventilation, but they all function similarly. Ventilation is necessary to allow carbon dioxide to go out and oxygen to get in, making sure that people are inhaling fresh air. Stagnant air causes the spreading of sickness, usually airborne, and allergies. But it is also essential to maintain an efficient ventilation system, especially in attics. Insufficient ventilation usually promotes the growth of bacteria and fungi such as molds because of high humidity. It will also decrease the effectiveness of rafter and roof sheathing insulation because of water vapor condensation.

The air-conditioning system controls the heat as well as ventilation. They often come in different sizes. Most air conditioners have large air ducts, so it is better to check out the building first to see if they can be installed. Or else, use the split system or remote coils. It is necessary, though, that air ducts are properly cleaned. Pathogens thrive in dirty air ducts. Return-air grills are also vulnerable to chemical, microbiological, and radiological elements. Thus, HVAC return-air grill height should be that it is not accessible but visible for any observation.

Fume Hoods

The following is taken from DOE-HDBK-1169-2003.

The wide, often unpredictable variety of chemical operations conducted in laboratory fume hoods makes selection and installation of high efficiency particulate air (HEPA) filters difficult and uncertain. Corrosive fumes may damage the filter and its mounting, and moisture and heat from hood operations may accelerate that damage. Operations that produce steam or moisture should be restricted to minimize condensation in the filter or the carryover of water and/or chemical droplets to the filter. The system should be designed so that any droplets will be vaporized prior to reaching the HEPA filter.

Some facilities install fume hood filters in the attic, usually directly above the hood served. Where this design is employed, the attic space should be designed as a confinement zone for easy cleanup in the event of a spill, and should not be used for extraneous purposes such as storage and experimental work when radioactive materials are handled in the hood.

Hood installations in which perchloric acid and certain other chemicals are handled should be provided with wash-down facilities to permit periodic decontamination of the hood and ductwork (perchloric acid hoods should not be used for handling other materials because of the explosion hazard). Offgas scrubbers are often provided in hoods. Both wash-down facilities and scrubbers generate substantial quantities of water droplets. Provision of demisters that meet the requirements should be considered to protect the filters and their mountings. Moisture collected in the demister should be conducted to a hood drain rather than permitted to fall into the workspace of the hood. Demisters should have adequate handling space and be easily accessible for cleaning, inspection, and replacement. Where incandescent particles or flaming trash can be released to the hood exhaust stream, a spark arrester may be needed to protect the HEPA filter. This arrester can be either a commercial flame arrester, a metal-mesh graded-density demister, or at minimum, a piece of 40-mesh metal cloth. In any event, it is recommended that the arrester be located at least 1 foot ahead of the HEPA filter and must be easily accessible for cleaning, inspection, and replacement.

Heat sources such as heating mantles, furnaces, and Bunsen burners are common equipment in laboratory fume hoods and should be planned for in the initial hood and exhaust system design. Designers should control heat-producing operations by limiting the size of heat sources, insulating furnaces, etc., or using air cooling methods.

Gloveboxes

The following is taken from DOE-HDBK-1169-2003.

Gloveboxes are enclosures that enable operators in various industries (e.g., nuclear, biological, pharmaceutical, microelectronics) to use their hands to manipulate hazardous materials through gloves without exposure to themselves or subsequent unfiltered release of the material to the environment. In the nuclear industry, gloveboxes provide primary confinement for radioactive material handling and process protection and are used to handle a diverse range of chemical, oxygen-sensitive, pyrophoric, hazardous, and nuclear materials. (Note: There are many other factors, [e.g., seismic, shielding, etc.] that could

impact glovebox filtration design and operation. Secondary confinement may be provided by the room or building where the gloveboxes are located.)

Ventilation is the heart of the glovebox system. Nuclear materials requiring handling inside a glovebox usually present little or no penetrating radiation hazard, but emit radioactive particles that could be dangerous if inhaled. Gloveboxes prevent operators from inhaling radioactive particles as they work with various nuclear materials and help provide a clean, controlled, safe working environment. For glovebox ventilation to be effective, however, proper design pressures and flow criteria must be maintained. Glovebox pressures range from mostly negative (for confinement) to positive pressure environments (for process protection). Failure to maintain correct operational pressures or to follow established operational procedures could render a glovebox both ineffective and unsafe.

The following is taken from DOE-STD-1128-2008.

Gloveboxes should be designed to operate at a negative pressure (0.75 ± 0.25 inch [in.] water gage (wg) with respect to the room in which they are operated. Differential pressure gauges should be installed on each glovebox or integrally connected series of gloveboxes. During abnormal conditions, control devices to prevent excessive pressure or vacuum should be either positive-acting or automatic or both. The ventilation system should be designed to provide and maintain the negative pressure during normal operations and the flow through a breach. There should be exhaust capacity on demand that will promptly cause an inflow of air greater than 125 linear feet per minute through a breach of at least a single glovebox penetration of the largest size possible. Filters, scrubbers, demisters, and other air-cleaning devices should be provided to reduce the quantities of toxic or noxious gases and airborne particulates that enter the ventilation system prior to its entry into the exhaust system.

Each glovebox or integrally connected series of gloveboxes should be equipped with an audible alarm that alerts personnel when a system pressure or vacuum loss is occurring. The alarm should be set at -0.5 in. wg relative to the room in which the glovebox is located. The number of penetrations for glovebox services should be minimized. The fittings should provide a positive seal to prevent the migration of radioactive material. For the same reason, penetrations for rotating shafts should not be permitted except where rotating shafts have seals. Seals for rotating shafts are very reliable and are preferred to motors inside the glovebox. Vacuum systems connected to a glovebox should be designed to prevent an evacuation and possible implosion of the glovebox.

Any gas-supply system connected directly to a glovebox should be designed to prevent pressurization, flow in excess of the exhaust capacity, and backflow.

Flammable or combustible gases should not be used in gloveboxes but if required, should be supplied from the smallest practical size of cylinders. Flammable gas piped to a plutonium processing building should not enter the building at a pressure exceeding 6 in. water. Vacuum pump exhaust should be filtered and exhausted to the glovebox or other acceptable exhaust system.

If process water is provided to a glovebox and the water must be valved on when the box is unattended, a system should be installed to automatically close a block valve in the water-supply line if a buildup of water is detected on the box floor or in the box sump.

Process piping to and from gloveboxes should be equipped with backflow prevention devices and should be of welded stainless steel construction. Vacuum breaker-type devices are generally more reliable than other types.

Glovebox components, including windows, gloves, and sealants, should be of materials that resist deterioration by chemicals and radiation.

Glove ports should be designed to allow for the replacement of gloves while maintaining control of radioactive material. The ports should be located to facilitate both operating and maintenance work. The need for two-handed operation, depth of reach, mechanical strength, and positioning with respect to other ports should be considered in the design. Covers or plugs should be provided for each port. The covers or plugs should provide shielding equivalent to the glovebox walls. Automatic glove-changing systems should be considered.

Bibliography and Suggested Reading

Code of Federal Regulations (CFR)

- 10 CFR 707 “Workplace Substance Abuse Programs at DOE Sites.” January 1, 2011.
- 10 CFR 707.13, “Medical Review of Results of Tests for Illegal Drug Use.”
January 1, 2011.
- 10 CFR 708, “DOE Contractor Employee Protection Program.” January 1, 2011.
- 10 CFR 712.14, “Medical Assessment.” January 1, 2011.
- 10 CFR 820, “Procedural Rules of DOE Nuclear Activities.” January 1, 2011.
- 10 CFR 820.24, “Preliminary Notice of Violation.” January 1, 2011.
- 10 CFR 830, “Nuclear Safety Management.” January 1, 2011.
- 10 CFR 830.3, “Definitions.” January 1, 2011.
- 10 CFR 830.120, “Quality Assurance.” January 1, 2011.
- 10 CFR 830.122, “Quality Assurance Criteria.” January 1, 2011.
- 10 CFR 835.103, “Education, Training, and Skills.” January 1, 2011.
- 10 CFR 835.202, “Occupational Dose Limits for General Employees.”
January 1, 2011.
- 10 CFR 835.206, “Limits for the Embryo/Fetus.” January 1, 2011.
- 10 CFR 835.207, “Occupational Dose Limits for Minors.” January 1, 2011.
- 10 CFR 835.208, “Limits for Members of the Public Entering a Controlled Area.”
January 1, 2011.
- 10 CFR 835.402, “Individual Monitoring.” January 1, 2011
- 10 CFR 835.403, “ Air Monitoring.” January 1, 2011.
- 10 CFR 835.1001, “Design and Control.” January 1, 2011.
- 10 CFR 835.1101, “Control of Material and Equipment.” January 1, 2011.
- 10 CFR 835, Subpart K, “Occupational Radiation Protection.” January 1, 2011.
- 10 CFR 850.11, “General CBDPP Requirements.” January 1, 2011.
- 10 CFR 850.12, “Implementation.” January 1, 2011.
- 10 CFR 850.34, “Medical Surveillance.” January 1, 2011.
- 10 CFR 850.38, “Warning Signs and Labels.” January 1, 2011.
- 10 CFR 851, “Worker Safety and Health.” January 1, 2011.
- 10 CFR 851.5, “Enforcement.” January 1, 2011.
- 10 CFR 851.11, “Development and Approval of Worker Safety and Health Program.”
January 1, 2011.
- 10 CFR 851.13, “Compliance.” January 1, 2011.
- 10 CFR 851, appendix A, “Worker Safety and Health Functional Areas.”
January 1, 2011.
- 10 CFR 900.4, “Pre-Application Mechanism.” January 1, 2010.
- 20 CFR 10.115, “What Evidence is Needed to Establish a Claim?” April 1, 2010.
- 20 CFR 10.330, “What are the Requirements for Medical reports?” April 1, 2010.
- 20 CFR 10.331, “How and When Should the Medical Report be Submitted?”
April 1, 2010.
- 20 CFR 10.332, “What Additional Medical Information Will OWCP Require to
Support Continuing Payment Of Benefits?” April 1, 2010.
- 20 CFR 10.333, “What Additional Medical Information Will OWCP Require to
Support a Claim for a Schedule Award?” April 1, 2010.
- 29 CFR 1904, “Recording and Reporting Occupational Injuries and Illnesses.”
July 1, 2010.
- 29 CFR 1904.7, “General Recording Criteria.” July 1, 2010

29 CFR 1910, "Occupational Safety and Health Standards." July 1, 2010.
29 CFR 1910.1, "Purpose and Scope." July 1, 2010.
29 CFR 1910.22, "General Requirements." July 1, 2010.
29 CFR 1910.23, "Guarding Floor and Wall Openings and Holes." July 1, 2010.
29 CFR 1910.25, "Portable Wood Ladders." July 1, 2010.
29 CFR 1910.26, "Portable Metal Ladders." July 1, 2010.
29 CFR. 1910.27, "Fixed Ladders." July 1, 2010.
29 CFR 1910.34, "Coverage and Definitions." July 1, 2010.
29 CFR 1910.35, "Compliance with NFPA 101- 2000." July 1, 2010.
29 CFR 1910.36, "Design and Construction Requirements for Exit Routes."
July 1, 2010.
29 CFR 1910.37, "Maintenance, Safeguards, and Operational Fixtures for Exit
Routes." July 1, 2010.
29 CFR 1910.38, "Emergency Action Plans." July 1, 2010.
29 CFR 1910.56, "Illumination." July 1, 2010.
29 CFR 1910.66, "Powered Platforms for Building Maintenance." July 1, 2010.
29 CFR 1910.67, "Vehicle Mounted Work Platforms." July 1, 2010.
29 CFR 1910.68, "Manlifts." July 1, 2010.
29 CFR 1910.95, "Occupational Noise Exposure." July 1, 2010.
29 CFR 1910.119, "Process Safety Management of Highly Hazardous Chemicals."
July 1, 2010.
29 CFR 1910.120, "Hazardous Waste Operations and Emergency Response."
July 1, 2010.
29 CFR 1910.134, "Respiratory Protection." July 1, 2010.
29 CFR 1910.137, "Electrical Protective Equipment." July 1, 2010.
29 CFR 1910.145, "Specifications for Accident Prevention Signs and Tags."
July 1, 2010.
29 CFR 1910.146, "Permit-required Confined Spaces." July 1, 2010.
29 CFR 1910.147, "The Control of Hazardous Energy." July 1, 2010.
29 CFR 1910.151, "Medical Services and First-Aid." July 1, 2010.
29 CFR 1910.157, "Portable Fire Extinguishers." July 1, 2010.
29 CFR 1910.158, "Standpipe and Hose Systems." July 1, 2010.
29 CFR 1910.159, "Automatic Sprinkler Systems." July 1, 2010.
29 CFR 1910.160, "Fixed Extinguishing Systems, General." July 1, 2010.
29 CFR 1910.161, "Fixed Extinguishing Systems, Dry Chemical," July 1, 2010.
29 CFR 1910.162, "Fixed Extinguishing Systems, Gaseous Agent." July 1, 2010.
29 CFR 1910.165, "Employee Alarm Systems." July 1, 2010.
29 CFR 1910.178, "Powered Industrial Trucks." July 1, 2010.
29 CFR 1910.179, "Overhead and Gantry Cranes." July 1, 2010.
29 CFR 1910.180, "Crawler Locomotive and Truck Cranes." July 1, 2010.
29 CFR 1910.181, "Derricks." July 1, 2010.
29 CFR 1910.184, "Slings." July 1, 2010.
29 CFR 1910.212, "General Requirements for all Machines." July 1, 2010.
29 CFR 1910.217, "Mechanical Power Presses." July 1, 2010.
29 CFR 1910.252, "General Requirements." July 1, 2010.
29 CFR 1910.1000, "Air Contaminants." July 1, 2010.
29 CFR 1910.1001, "Asbestos." July 1, 2010.
29 CFR 1910.1030, "Blood-borne Pathogens." July 1, 2010.
29 CFR 1910.1096, "Ionizing Radiation." July 1, 2010.

29 CFR 1910.1200, "Hazard Communication." July 1, 2010.

29 CFR 1910.1201, "Retention of DOT Markings, Placards and Labels." July 1, 2010.

29 CFR 1910.1450, "Occupational Exposure to Hazardous Chemicals in Laboratories." July 1, 2010.

29 CFR 1910, Subpart F, "Powered Platforms, Manlifts and Vehicle Mounted Work Platforms." July 1, 2010.

29 CFR 1910, Subpart Z, "The Specific Toxic and Hazardous Substance Regulations." July 1, 2010.

29 CFR 1915.159, "Personal Fall Arrest Systems." July 1, 2010.

29 CFR 1926, "Safety and Health Regulations for Construction." July 1, 2010.

29 CFR 1926.1, "Purpose and Scope." July 1, 2010.

29 CFR 1926.20, "General Safety and Health Provisions." July 1, 2010.

29 CFR 1926.50, "Medical Services and First Aid." July 1, 2010.

29 CFR 1926.62, "Lead." July 1, 2010.

29 CFR 1926.65, "Hazardous Waste Operations and Emergency Response." July 1, 2010.

29 CFR 1926.501, "Duty to Have Fall Protection." July 1, 2010.

29 CFR 1926.502, "Fall Protection Systems Criteria and Practices." July 1, 2010.

29 CFR 1926.651, "Specific Excavation Requirements." July 1, 2010.

29 CFR 1926.652, "Requirements for Protective Systems." July 1, 2010.

29 CFR 1926.803, "Compressed Air." July 1, 2010.

29 CFR 1926.850, "Preparatory Operations." July 1, 2010.

29 CFR 1926.851, "Stairs, Passageways, and Ladders." July 1, 2010.

29 CFR 1926.852, "Chutes." July 1, 2010.

29 CFR 1926.853, "Removal of Materials Through Floor Openings." July 1, 2010.

29 CFR 1926.854, "Removal of Walls, Masonry Sections, and Chimneys." July 1, 2010.

29 CFR 1926.855, "Manual Removal of Floors." July 1, 2010.

29 CFR 1926.856, "Removal of Walls, Floors, and Material with Equipment." July 1, 2010.

29 CFR 1926.857, "Storage." July 1, 2010.

29 CFR 1926, Subpart M, "Fall Protection." July 1, 2010.

29 CFR 1960, "Basic Program Elements for Federal Employee Occupational Safety and Health Programs and Related Matters." July 1, 2010.

29 CFR 1960.1, "Purpose and Scope." July 1, 2010.

29 CFR 1960.2, "Definitions." July 1, 2010.

29 CFR 1960.6, "Designation of Agency Safety and Health Officials." July 1, 2010.

29 CFR 1960.7, "Financial Management." July 1, 2010.

29 CFR 1960.8, "Agency Responsibilities." July 1, 2010.

29 CFR 1960.16, "Compliance with OSHA Standards." July 1, 2010.

30 CFR 57.14107, "Moving Machine Parts." July 1, 2010.

40 CFR 302, "Designation, Reportable Quantities, and Notification." July 1, 2010.

48 CFR 923.7002, "Worker Safety and Health." October 1, 2010.

48 CFR 952.223-76, "Conditional Payment of Fee or Profit—Safeguarding Restricted Data and Other Classified Information and Protection of Worker Safety and Health." October 1, 2010.

48 CFR 952.223-77, "Conditional Payment of Fee or Profit—Protection of Worker Safety and Health." October 1, 2010.

- 48 CFR 970.5204-2, “Laws, Regulations, and DOE Directives.” October 1, 2010.
 48 CFR 970.5223-1, “Integration of Environment, Safety, and Health into Work Planning and Execution.” October 1, 2010.
 49 CFR 391.45, “Physical Qualifications for Drivers.” October 1, 2010.
 49 CFR 396.13, “Driver Inspection.” October 1, 2010.
 49 CFR 396.15, “Driveaway-Towaway Operations and Inspections.” October 1, 2010.

All About Eye Safety, Eye Safety in the Workplace.

American Bankers, Appendix A, Ergonomic Risk Factor Descriptions and Examples to be Included in Required Awareness Training [section C(1)(a)].

American National Standards Institute

- ANSI A10.14-1991, *American National Standard for Construction and Demolition Operations, Requirements for Safety Belts, Harnesses, Lanyards and Lifelines for Construction and Demolition Use*. 1991.
 ANSI A10.32-2004, *Fall Protection Systems for Construction and Demolition Operations*. 2004.
 ANSI A11.1-1965, R1970, *Practice for Industrial Lighting*. 1970.
 ANSI/ASC A14.3-2008, *American National Standards for Ladders—Fixed—Safety Requirements*. 2008.
 ANSI A92.2-2009, *Vehicle Mounted Elevating and Rotating Work Platforms*. 2009.
 ANSI B56.1-1969, *Safety Standard for Powered Industrial Trucks*. 1969.
 ANS/IEEE C95.1, *Safety Levels with Respect to Human Exposure to Radio Frequency Electromagnetic Fields, 300 kHz to 100 GHz*. 2005.
 ANSI/ASME NQA-1-2008, *Quality Assurance Requirements for Nuclear Facility Applications*. 2008.
 ANSI/ISO/ASQ Q 9001-2008, *Quality Management System: Requirements*. 2000.
 ANSI/ASQ Z1.13, *Quality Guidelines for Research*. 1999.
 ANSI Z136.1-2007, *American National Standard for Safe Use of Lasers*. 2007.
 ANSI Z308.1-1998, *Minimum Requirements for Workplace First-aid Kits*. 1998.
 ANSI/ASSE, Z359.1-2007, *Safety Requirements for Personal Fall Arrest Systems, Subsystems and Components*. 2007.

American Society of Mechanical Engineers

- ASME A90.1, *Safety Standard for Belt Manlifts*. April 2009.
 ASME B 30.2-2005, *Overhead and Gantry Cranes (Top Running Bridge, Single or Multiple Girder, Top Running Trolley Hoist)*. 2005
 ASME B30.5-2007, *Mobile and Locomotive Cranes*. 2007.
 ASME B 30.9-2010, *Slings*. 2010.
 ASME B30.10-2009, *Hooks*. 2009.
 ASME B30.11-2010, *Monorails and Underhung Cranes*. 2010.
 ASME B30.16-2007, *Overhead Hoists (Underhung)*. 2007.
 ASME B30.17-2006, *Overhead and Gantry Cranes (Top Running Bridge, Single Girder, Underhung Hoist)*. 2006.
 ASME B30.21-2005, *Manually Lever Operated Hoists*. 2005.
 ASME B30.26-2010, *Rigging Hardware*. 2010.
 ASME/ANSI B 36.10M-2004, *Welded and Seamless Wrought Steel Pipe*. 2004.
 ASME/ANSI B36.19 2004, *Stainless Steel Pipe*. 2004.

Benjamin Bloom's Taxonomy of Behavioral Objectives.

Berkley Laboratory, Environment, Health & Safety Division

Chemical Toxicology Overview.

Chemical Hygiene and Safety Plan, Chemical Storage Guidelines.

Brookhaven National Laboratory, Prince-Anderson Amendments Act.

Builder: Quality Control vs. Quality Assurance

Buzzle.com, Oxygen Analyzer Features and Uses.

Canadian Centre for Occupational Health and Safety

Corrosive Materials and Their Hazards.

Vibration—Health Effects. October 21, 2008.

Centers for Disease Control and Prevention

Vaccinations. November 13, 2009.

Antimicrobial Prophylaxis to Prevent Anthrax Among Decontamination/Cleanup

Workers Responding to an Intentional Distribution of Bacillus Anthracis

Biological Agents. 2002.

Yellow Book.

City of Scottsdale, Design Standards & Policies Manual.

Concrete Reinforcing Steel Institute, Reinforcing Bars: Embedded Strength of Reinforced Concrete. 2010.

Construction and Equipment, *Beware of Vulnerabilities During Construction.* March 25, 2004.

Dartmouth College, ChemLab, Safety Hazards in the Lab.

Denison University—Confined Space Plan.

dynamicflight.com, The Learning Process.

eHow, How to Use a Spotter for Moving Cranes & Heavy Equipment. January 13, 2011.

Encyclopedia of Mental Disorders, Behavior Modification. 2011.

Environmental Health and Safety (EH&S), *Fact Sheet: Chemical Monitoring and Sampling.*

Executive Orders

EO 12196, "Occupational Safety and Health Programs for Federal Employees."

February 26, 1980.

EO 13335, "Incentives for the Use of Health Information Technology." April 27,

2004.

Fabricator's and Manufacturer's Association, Welding Effects on Strengthening Steel.

December 11, 2003.

Federal Aviation Association, System Safety Handbook, Chapter 9: Analysis Techniques.

Federal Employee's Worker Compensation Legal Library.

FirefighterCentral.com, What is Fire?

Forastieri. Dr. V., Occupational Health Services at the Workplace.

Hvachome.net, What is HVAC?

Idaho National Laboratory. The Sapphire Program.

Industrial Accident Prevention Association. Preventive Maintenance.

Integrated Publishing, Engine Mechanics, Boom Angle Indicators.

International Labour Association, Cleaning. March 11, 2000.

Iowa State University, Department of Environmental Health and Safety, Health and Safety. Repetition. 2005.

I. Weiss, Fire Safety Curtains.

Institute for Electrical and Electronics Engineers, IEEE-USA Operations Manual, Part A: Policies, Guidelines, and Procedures.

Institute of Nuclear Power Operations, INPO.com

Linux, Firewall.

Los Alamos National Laboratory (LANL). LANL Engineering Standards Manual OST220-03-01-ESM, *Section D20, Plumbing/Piping Vessels—App A, ASME B31.3, Process Piping Guide*. June 9, 2004.

Lawrence Berkeley National Laboratory, Publication 3000, *Health and Safety Manual*. October 2010.

Lawrence Livermore National Laboratory, ES&H Manual, volume II: Health & Safety, Controls and Hazards, Document 16.1: Electrical Safety. July 1, 2003.

Layne, Oxidizers.

Louisville, Kentucky Government, Bicycle and Pedestrian Safety.

Loyola University New Orleans, Chapter 10, Perception, Attitudes, Beliefs, and Values.

Mason Contractor's Association of America, Scaffolding Hazards—Avoiding Common Mistakes. May 26, 2001.

Massachusetts Institute of Technology, Appendix VI, What If Hazard Analysis. *Missouri Driver Guide*, chapter 8.

Mostyn Law Firm's Beyond Expectations, *Injury from Toxic Substances...Answers to Your Questions*.

Muller, Richard A, Physics for Future Presidents, Chapter 1, Energy, Power, and Explosions. February 2, 2002.

National Aeronautics and Space Administration
NASA 8719.7, *Facility System Safety Guidebook*. January 1998.
Science Content Standards: 5-8, Guide to the Content Standard

National Archives and Records Administration, Rules and Regulations.

National Fire Protection Association

- NFPA 30, *Flammable and Combustible Liquids Code*. 1969.
- NFPA 58, *Storage and Handling of Liquefied Petroleum Gases*. 1969.
- NFPA 70, *National Electrical Code*. 2011.
- NFPA 70E, *Standard for Electrical Safety Requirements for Employee Workplaces*. 2004.
- NFPA 101, *Life Safety Code*. 2009.
- NFPA 780, *Standard for Lightning Protection*. 2011.
- NFPA 1582, *Standard on Comprehensive Occupational Medical Program for Fire Departments*. 2007.

National Institute for Occupational Safety and Health

- NIOSH Manual of Analytical Methods. January 15, 1998.
- NIOSH Program Area: Radiation Dose Reconstruction.
- NIOSH Publication No. 97-117, *Elements of Ergonomics Programs*. March 1997.
- NIOSH Publication No. 2003-154, *NIOSH Manual of Analytical Methods*, Chapter D, General Considerations for Sampling Airborne Contaminants. 2003.
- Preventing Occupational Exposures to Lead and Noise at Indoor Firing Ranges. April 2009.
- U.S. Army Corp of Engineers, Surface Danger Zones.
- Violence in the Workplace, Developing and Implementing a Workplace Violence Prevention Program and Policy. July 16, 1996.

National Research Council Canada. CMD-115, Performance of Building Materials. July 1969.

Naval Safety Center

- Acquisition Safety Human Factors Engineering and Ergonomics.
- Acquisition Safety—Confined Spaces.

Navy Medicine, Glossary of Common Industrial Hygiene Terms.

Occupational Safety and Health Administration

- OSHA 2254, *Training Requirements in OSHA Standards and Training Guidelines*. 1998
- OSHA 3138-01R, *Permit Required Confined Spaces*. 2004
- OSHA 3143, *Informational Booklet on Industrial Hygiene*. 1998.
- OSHA, Course 700: Introduction to Safety Management, Module Three: Employee Involvement.
- OSHA, Demolition.
- OSHA, Safety & Health Management Systems e-Tool, Fact Sheets—Employee Involvement.
- OSHA, Safety & Health Management Systems e-Tool, Fact Sheets—Management Leadership.
- OSHA, Safety & Health Management Systems e-Tool, Fact Sheets—Safety and Health Training.
- OSHA, Safety & Health Management Systems e-Tool, Fact Sheets—Worksite Analysis.

OSHA, Safety & Health Management Systems e-Tool, Responsibility, Authority and Accountability.

OSHA Technical Manual, Heat Stress. January 20, 1999.

OSHA Technical Manual, section II, chapter I, Personal Sampling for Air Contaminants. January 20, 1999.

OSHA Technical Manual, section II, chapter 3, Technical Equipment: On-site Measurements. January 20, 1999.

OSHA Technical Manual, section III, chapter 3, Ventilation Investigation. January 20, 1999.

OSHA Technical Manual, section III, chapter VI, Laser Hazards. January 20, 1999.

OSHAcademy, Event and Causal Factor Charting.

OSHA Publications, Air Monitoring.

Office of Compliance, Safety and Health Fast Facts, Exposed Energized Wiring and Electrical Components. February 2006.

Office of Personnel Management, Qualification Standards for General Schedule Positions, Computer Science Series, 1550, Associated Group Standard.

Oklahoma Department of Labor, Essential Elements of an Effective Safety & Health Program.

Personality, Perception, and Attribution, South-Western Educational Publishing, Chapter 3.

Portland Cement Association
Cement and Concrete Basics. 2011.
Post-Tensioned Concrete. 2011.

ProcessOperations.com., Chemical Incompatibility Hazards.

Project Management Knowledge—Risk Acceptance.

Public Law 91-596, Occupational Safety and Health Act of 1970.

Reference for Business, Encyclopedia of Business, 2nd edition, Organizational Behavior.

Roads and Bridges, volume 43, number 1, New Catch Phrases. January 2005.

RTW Colorado, Inc., Loss Prevention Info Sheet, Rules of the Road—Safe Driving Tips.

Sacramento State Environmental Health and Safety, Chemical Hygiene Plan, Definitions.

Scaffolding Matters, Common Regulations When Using Various Forms of Scaffolding.

Space Science, *Oxidizing Liquids & Solids—Hazards*.

Technical Safety Institute, HAZWOPER Refresher Training.

TECNOMATIX, Task Analysis Toolkit.

The Center to Protect Worker’s Rights, Operating Heavy Equipment.

TheFabricator.com.

Underwriter's Laboratory, UL Standard UL 1097, *Standard for Safety Double Insulation Systems for Use in Electrical Equipment*. July 30, 2004.

Unified Facilities Guide Specifications, UFGS-33 52 80, *Liquid Fuels Pipeline Coating Systems*. February 2010.

U.S. Department of Defense

UFC 3-340-02, *Structures to Resist the Effects of Accidental Explosions*. December 5, 2008.

DoD 6055-9, *Ammunition and Explosives Safety Standards*.

U.S. Department of Energy Directives (Guides, Manuals, Orders, and Policies)

DOE Guide 10 CFR 835/E1-Rev. 1, *Implementation Guide for use with Title 10, Code of Federal Regulations, Part 835 Occupational Radiation Protection* (Archived). November 1994.

DOE Guide 120.1-5, *Guidelines for Performance Measurement*. June 30, 1996.

DOE Guide 225.1-1A, *Implementation Guide for Use with DOE Order 225.1A, Accident Investigations*. November 26, 1997.

DOE Guide 252.1-1, *Technical Standards Program Guide*. November 19, 1999.

DOE Guide 413.3-7A, *Risk Management Guide*. January 18, 2011.

DOE Guide 414.1-1B, *Management and Independent Assessments Guide for Use with 10 CFR Part 830, Subpart A, and DOE O 414.1C, Quality Assurance; DOE M 450.4 -1, Integrated Safety Management System Manual; and DOE O 226.1A, Implementation of DOE Oversight Policy*. September 27, 2007.

DOE Guide 414.1-5, *Corrective Action Program Guide*. March 2, 2006.

DOE Guide 420.1-2, *Guide for the Mitigation of Natural Phenomena Hazards for DOE Nuclear Facilities and Nonnuclear Facilities*. March 28, 2000.

DOE Guide 421.1-2, *Implementation Guide for Use in Developing Documented Safety Analyses to Meet Subpart B Of 10 CFR 830*. October 24, 2001.

DOE Guide 440.1-1A, *Worker Protection Program for DOE (including the National Nuclear Security Administration) Federal Employees Guide for Use with DOE O 440.1B*. June 4, 2007.

DOE Guide 440.1-1C, *Radiation Protection Programs Guide for Use with Title 10, Code of Federal Regulations, Part 835, Occupational Radiation Protection*. May 19, 2008.

DOE Guide 440.1-2, *Construction Safety Management Guide for Use with DOE O 440.1*. June 26, 1997.

DOE Guide 440.1-7A, *Implementation Guide for use with 10 CFR Part 850, Chronic Beryllium Disease Prevention Program*. January 1, 2001.

DOE Guide 440.1-8, *Implementation Guide for Use with 10 CFR Part 851, Worker Safety and Health Programs*. December 27, 2006.

DOE Guide 442.1-1, *Department of Energy Employee Concerns Program Guide*. February 1, 1999.

DOE Guide 450.3-3, *Tailoring for Integrated Safety Management Applications*. February 1997.

DOE Guide 450.4-1B, *Integrated Safety Management System Guide for use with Safety Management System Policies (DOE P 450.4, DOE P 450.5, AND DOE P 450.6); The Functions, Responsibilities, and Authorities Manual; and the Department of Energy Acquisition Regulation*. March 1, 2001.

DOE Manual 231.1-2, *Occurrence Reporting and Processing of Operations Information*. August 19, 2003.

DOE Manual 411.1-1C, *Safety Management Functions, Responsibilities and Authorities Manual*. December 31, 2003.

DOE Manual 426.1-1A, *Federal Technical Capability Manual* (Archived). May 18, 2004.

DOE Manual 440.1-1A, *DOE Explosives Safety Manual*. January 9, 2006.

DOE Manual 470.4-3A, *Contractor Protective Force*. November 5, 2008.

DOE Manual 470.4-8, *Federal Protective Force*. July 15, 2009.

DOE Order 151.1C, *Comprehensive Emergency Management System*. November 2, 2005.

DOE Order 205.1A, *Department of Energy Cyber Security Management*. December 4, 2006.

DOE Order 225.1B, *Accident Investigations*. March 8, 2011.

DOE Order 226.1B, *Implementation of Department of Energy Oversight Policy*. January 14, 2011.

DOE Order 231.1A, *Environment, Safety and Health Reporting*. June 3, 2004.

DOE Order 251.1C, *Departmental Directives Program*. January 15, 2009.

DOE Order 252.1, *Technical Standards Program*. November 19, 1999.

DOE Order 410.1, *Central Technical Authority Responsibilities Regarding Nuclear Safety Requirements*. August 28, 2007.

DOE Order 413.3B, *Program and Project Management for the Acquisition of Capital Assets*. November 29, 2010.

DOE Order 414.1C, *Quality Assurance*. June 17, 2005.

DOE Order 420.1B, *Facility Safety*. December 22, 2005.

DOE Order 426.1, *Federal Technical Capability*. November 19, 2009.

DOE Order 426.2, *Personnel Selection, Training, Qualification, and Certification Requirements for DOE Nuclear Facilities*. April 21, 2010.

DOE Order 433.1B, *Maintenance Management Program for DOE Nuclear Facilities*. April 21, 2010.

DOE Order 440.1B, *Worker Protection Program for DOE (Including the National Nuclear Security Administration) Federal Employees*. May 17, 2007.

DOE Order 450.1A, *Environmental Protection Program*. June 4, 2008.

DOE Order 452.2D, *Nuclear Explosive Safety*. April 14, 2009.

DOE Order 3790.1B, *Federal Employee Occupational Safety and Health Program*, (Archived). January 7, 1993.

DOE Order 5480.7A, *Fire Protection*, (Archived). February 17, 1993.

DOE Policy 226.1A, *Department of Energy Oversight Policy*. May 25, 2007.

DOE Policy 411.1, *Safety Management Functions, Responsibilities, and Authorities Policy*. January 28, 1997.

DOE Policy 450.4, *Safety Management System Policy*. October 15, 1996.

U.S. Department of Energy Handbooks and Standards

DOE-HDBK-1010-92, *DOE Fundamentals Handbook: Classical Physics*. June 1992.

DOE-HDBK-1011-92, volumes 1, 2, 3, and 4, *DOE Fundamentals Handbook: Electrical Science*. June 1992.

DOE-HDBK-1013/1-92, *DOE Fundamentals Handbook: Instrumentation and Control*. June 1992.

DOE-HDBK-1014-92, volumes 1 and 2, *DOE Fundamentals Handbook: Mathematics*. June 1992.

DOE-HDBK-1015-93, volumes 1 and 2, *DOE Fundamentals Handbook: Chemistry*. January 1993.

DOE-HDBK-1016-93, volumes 1 and 2, *DOE Fundamentals Handbook, Engineering Symbology, Prints, and Drawings*. January 1993.

DOE-HDBK-1017-93, volumes 1 and 2, *DOE Fundamentals Handbook: Material Science*. January 1993.

DOE-HDBK-1018-93, volumes 1 and 2, *DOE Fundamentals Handbook, Mechanical Science*. January 1993.

DOE-HDBK-1028-2009, *DOE Standard: Human Performance Improvement Handbook, Volume 1, Concepts and Principles*. June 2009.

DOE-HDBK-1078-94, *DOE Handbook: Training Program Handbook: A Systematic Approach to Training*. August 1994.

DOE-HDBK-1092-2004, *DOE Handbook: Electrical Safety*. December 2004.

DOE-HDBK-1100-2004, *Chemical Process Hazard Analysis*. August 2004.

DOE-HDBK-1101-2004, *DOE Handbook: Process Safety Management for Highly Hazardous Chemicals*. August 2004.

DOE-HDBK-1132-99, *DOE Handbook: Design Considerations*. April 1999.

DOE-HDBK-1163-2003, *DOE Handbook: Integration of Multiple Hazard Analysis Requirements and Activities*. October 2003.

DOE-HDBK-1169-2003, *DOE Handbook: Nuclear Air Cleaning Handbook*. November 2003.

DOE-HDBK-1188-2006, *DOE Handbook: Glossary of Environment, Safety and Health Terms*. January 2006.

DOE-NE-STD-1004-92, *DOE Guideline: Root Cause Analysis Guidance Document*. February 1992.

DOE-STD-1032-92, *Guide to Good Practices for Operations Organization and Administration*. December 1998.

DOE-STD-1070-94, *Guidelines for Evaluation of Nuclear Facility Training Programs*. June 1994.

DOE-STD-1073-2003, *DOE Standard: Configuration Management*. October 2003.

DOE-STD-1088-95, *Fire Protection for Relocatable Structures*. June 1995.

DOE-STD-1090-2007, *Hoisting and Rigging Standard*. August 2007.

DOE-STD-1091-96, *DOE Standard: Firearms Safety* (Archived). February 1996.

DOE-STD-1120-2005, *Integration of Environment, Safety, and Health into Facility Disposition Activities*. April 2005.

DOE-STD-1160-2011, *Occupational Safety Functional Area Qualification Standard*. July 2011.

DOE-STD-1189-2008, *DOE Standard: Integration of Safety into the Design Process*. January 2006.

DOE-STD-3006-2010, *Planning and Conducting Readiness Reviews*. 2010.

DOE-STD-3009-94, *DOE Standard: Preparation Guide for U.S Department of Energy Nonreactor Nuclear Facility Documented Safety Analyses*. March 2006.

DOE-STD-3011-2002, *Guidance for Preparation of Basis for Interim Operation (BIO) Documents*. December 2002.

DOE-STD-6005-2001, *Industrial Hygiene Practices*. April 2001.

DOE-STD-7501-95, *Development of DOE Lessons Learned Programs*. December 1999.

U.S. Department of Energy Other References

- Activity Level Work Planning and Control Processes: Attributes, Best Practices, and Guidance for Effective Incorporation of Integrated Safety Management and Quality Assurance.* January 2006.
- CAIRS Reference Manual.* February 2007.
- Conducting Accident Investigations.* May 1999.
- DOE/CBFO-94-1012, *DOE Carlsbad Field Office, Quality Assurance Program Description.* June 2010.
- DOE/EH-0486, *Integrating Safety and Health During Deactivation with Lessons Learned from Purex.* September 1995.
- DOE/EH-0705, *Safety Performance of Security Forces at the Department of Energy Facilities.* December 2005.
- DOE/EH-413/9713, *Glossary of Terms Related to CERCLA, EPCRA, PPA, RCRA & TSCA.* September 1997.
- DOE Employee Assistance Program.
- DOE, Energy Efficiency and Renewable Energy, *Improving Compressed Air System Performance: A Sourcebook for Industry, U.S.*
- DOE GPG-FM-027, *Human Factors Engineering.* March 1996.
- DOE Guide to Workforce Planning.*
- DOE Motor Vehicle Management Handbook.* September 2007.
- DOE Office of Health, Safety, and Security, *Automated Job Hazard Analysis.*
- DOE Office of Health Safety, and Security, *Who We Are.*
- DOE/RW-0333P *DOE Office of Civilian Radioactive Waste Management, Quality Assurance Requirements and Description.* July 20, 2007.
- DOE/TIC-11268, *A Manual for the Prediction of Blast and Fragment Loadings on Structures.* August 15, 1981.
- Department of Energy Technical Standards Program Procedures.* 2009.
- Energy Facility Contractors Group's DOE Electrical Safety Improvement Project, Project Area 4—Performance Measurement, Electrical Severity Measurement Tool Revision 1. April 16, 2007.
- Federal Assurance Capability Plan Inspection, Criteria and Approach, DNFSB 2004-1, Commitment 16. February 11, 2009.
- Federal Employee Occupational Safety and Health (FEOSH) Program Overview.
- FEOSH Program Review, Workplace Inspections, Hazards Analysis and Abatement.
- Incident Investigation: DOE ORPS Reportable Investigation Procedure.
- Memorandum of Understanding Between the U.S. Department of Labor and the U.S. Department of Energy. June 19, 1995.
- Overview of the Department of Energy's Procurement System, Management and Operating Contracts.
- Thomas Jefferson National Accelerator Facility, *Suspect/Counterfeit Item Awareness.* September 25, 2008.

U.S. Department of Health and Human Services

- Agency for Toxic Substances & Disease Registry (ATSDR), *Appendix B: ATSDR Glossary of Terms.*
- ATSDR, *A Toxicology Curriculum for Communities Trainer's Manual.*

- U.S. Department of Labor, Occupational Safety and Health Administration**
Controlling Electrical Hazards.
Crystalline Silica Exposure.
Ergonomics—Contributing Conditions.
Green Job Hazards: Wind Energy—Crane, Derrick and Hoist Safety.
Guidance on Safe Sling Use.
Guidelines for Laser Safety and Hazard Assessment. August 5, 1991.
Hand and Power Tools, Construction Safety and Health Outreach Program. May 1996.
Hazards Associated with the Unintended (Double) Cycling of Mechanical Power Presses. February 23, 2010.
Nonionizing Radiation.
Office of Worker’s Compensation Program.
Overhead Power Line Safety Tips for the Construction Industry.
Safety and Health Management eTool, Worksite Analysis.
Sample Fall Protection Plan. January 26, 1995.
Sample Safety and Health Program for Small Business.
SLAC National Accelerator Laboratory, Inspection Criteria for Rigging Accessories and Wire Rope and Slings per DOE-STD-1090-2007.
SLAC National Accelerator Laboratory, ES&H, Industrial Hygiene. August 23, 2010.
Welding Health Hazards.
Materials Handling and Storage. May 1996.
The Application of HAZWOPER to Worksite Response and Cleanup Activities.
The Cold Stress Equation. 1998.
Thermal Burns.
- U.S. Army Corp of Engineers, Surface Danger Zones.
- U.S. Energy Information Administration, Electric Conversions.
- Virginia Tech, Environmental, Health and Safety Services, *Confined Spaces and Definitions*.
- Washington State University, Environmental Health and Safety (EH&S), Fact Sheet: Chemical Monitoring and Sampling.
- Westinghouse Hanford Corporation, WHC-SD-GN-FHA-30001 Rev, 0, Integration of Fire Hazards Analysis and Safety Analysis Report Requirements. September 9, 1994.
- Webster’s Online Dictionary, Extended Definition—Light Meter.
- Wheeler, Michael D. and Christine A. Roeger, *Cryogenic Liquids and the Scientific Glassblower*.
- WorkRite Ergonomics, Glossary of Ergonomic Terms.

**Occupational Safety
Qualification Standard
Reference Guide
JULY 2011**