

A Unified Approach for Motion and Force Control of Robot Manipulators: The Operational Space Formulation

OUSSAMA KHATIB, MEMBER, IEEE

Abstract—A framework for the analysis and control of manipulator systems with respect to the dynamic behavior of their end-effectors is developed. First, issues related to the description of end-effector tasks that involve constrained motion and active force control are discussed. The fundamentals of the operational space formulation are then presented, and the unified approach for motion and force control is developed. The extension of this formulation to redundant manipulator systems is also presented, constructing the end-effector equations of motion and describing their behavior with respect to joint forces. These results are used in the development of a new and systematic approach for dealing with the problems arising at kinematic singularities. At a singular configuration, the manipulator is treated as a mechanism that is redundant with respect to the motion of the end-effector in the subspace of operational space orthogonal to the singular direction.

I. INTRODUCTION

RESEARCH in dynamics of robot mechanisms has largely focused on developing the equations of joint motions. These joint space dynamic models have been the basis for various approaches to dynamic control of manipulators. However, task specification for motion and contact forces, dynamics, and force sensing feedback are closely linked to the end-effector. The dynamic behavior of the end-effector is one of the most significant characteristics in evaluating the performance of robot manipulator systems. The problem of end-effector motion control has been investigated, and algorithms resolving end-effector accelerations have been developed [7], [11], [22], [30], [33].

The issue of end-effector dynamic modeling and control is yet more acute for tasks that involve combined motion and contact forces of the end-effector. Precise control of applied end-effector forces is crucial to accomplishing advanced robot assembly tasks. This is reflected by the research effort that has been devoted to the study of manipulator force control. Accommodation [35], joint compliance [26], active stiffness [31], impedance control [9], and hybrid position/force control [28] are among the various methods that have been proposed.

Force control has been generally based on kinematic and static considerations. While in motion, however, a manipulator end-effector is subject to inertial, centrifugal, and Coriolis

forces. The magnitude of these dynamic forces cannot be ignored when large accelerations and fast motions are considered. Controlling the end-effector contact forces in some direction can be strongly affected by the forces of coupling created by the end-effector motion that can take place in the subspace orthogonal to that direction. The description of the dynamic interaction between end-effector motions and the effects of these motions on the end-effector's behavior in the direction of force control are basic requirements for the analysis and design of high-performance manipulator control systems. Obviously, these characteristics cannot be found in the manipulator joint space dynamic model, which only provides a description of the interaction between joint motions. High-performance control of end-effector motion and contact forces requires the description of how motions along different axes are interacting, and how the apparent or equivalent inertia or mass of the end-effector varies with configurations and directions.

The description, analysis, and control of manipulator systems with respect to the dynamic characteristics of their end-effectors has been the basic motivation in the research and development of the operational space formulation. The end-effector equations of motion [13], [14] are a fundamental tool for the analysis, control, and dynamic characterization [18] of manipulator systems. In this paper, we will discuss, from the perspective of end-effector control, the issue of task description, where constrained motions and contact forces are involved. The fundamentals of the operational space formulation are presented, and the unified approach for the control of end-effector motion and contact forces is developed.

Treated within the framework of joint space control systems, redundancy of manipulator mechanisms has been generally viewed as a problem of resolving the end-effector desired motion into joint motions with respect to some criteria. Manipulator redundancy has been aimed at achieving goals such as the minimization of a quadratic criterion [29], [34], the avoidance of joint limits [5], [21] the avoidance of obstacles [4], [6], [20], kinematic singularities [23], or the minimization of actuator joint forces [8]. The end-effector equations of motion for a redundant manipulator are established and its behavior with respect to generalized joint forces is described. The unified approach for motion and active force control is then extended to these systems.

Kinematic singularities is another area that has been considered within the framework of joint space control and

Manuscript received August 6, 1985; revised May 29, 1986. This work was supported in part by the National Science Foundation and in part by the Systems Development Foundation.

The author is with the Artificial Intelligence Laboratory, Computer Science Department, Cedar Hall, Stanford University, Stanford, CA 94305.

IEEE Log Number 8610323.

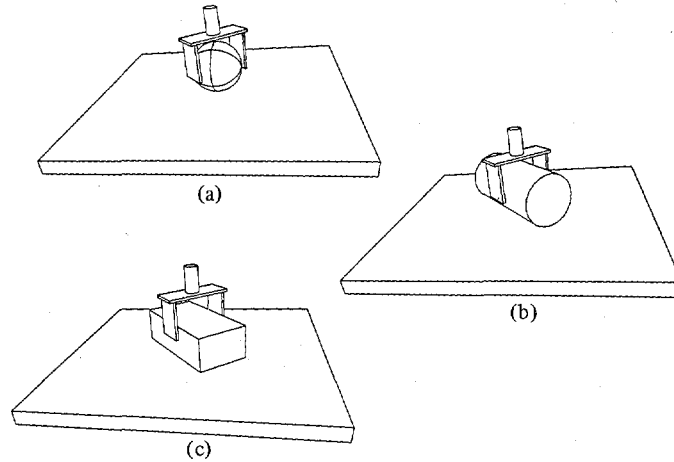

Fig. 1. Constrained end-effector freedom of motion. (a) Five degrees of freedom. (b) Four degrees of freedom. (c) Three degrees of freedom.

formulated in terms of resolution of the task specifications into joint motions. Generalized inverses and pseudo-inverses have been used, and recently an interesting solution based on the singularity robust inverse has been proposed [25]. In this paper, a new approach for dealing with the problem of kinematic singularities within the operational space framework is presented. In the neighborhood of a singular configuration the manipulator is treated as a redundant mechanism with respect to the motion of the end-effector in the subspace of operational space orthogonal to its singular direction. Control of the end-effector for motions along the singular direction is based on the use of the kinematic characteristic of the Jacobian matrix.

II. GENERALIZED TASK SPECIFICATION MATRICES

The end-effector motion and contact forces are among the most important components in the planning, description, and control of assembly operations of robot manipulators. The end-effector configuration is represented by a set of m parameters, x_1, x_2, \dots, x_m , specifying its position and orientation in some reference frame. In free motion operations, the number of end-effector degrees of freedom m_0 is defined [13] as the number of independent parameters required to specify completely, in a frame of reference \mathcal{R}_0 , its position and orientation. A set of such independent configuration parameters forms a system of operational coordinates.

In constrained motion operations, the displacement and rotations of the end-effector are subjected to a set of geometric constraints. These constraints restrict the freedom of motion (displacements and rotations) of the end-effector. Clearly, geometric constraints will affect only the freedom of motion of the end-effector, since static forces and moments at these constraints can still be applied. The number of degrees of freedom of the constrained end-effector is given by the difference between m_0 and the number of independent equations specifying the geometric constraints, assumed to be holonomic. Examples of five-, four-, and three-degree-of-freedom constrained end-effectors are shown in Fig. 1.

An interesting description of the characteristics of end-effectors and their constraints uses a mechanical linkage representation [5], [24]. The end-effector, tool, or manipu-

lated object forms, with the fixture or constrained object, a pair of two rigid bodies linked through a joint. A constrained motion task can be described, for instance, by a spherical, planar, cylindrical, prismatic, or revolute joint.

However, when viewed from the perspective of end-effector control, two elements of information are required for a complete description of the task. These are the vectors of total force and moment that are to be applied to maintain the imposed constraints, and the specification of the end-effector motion degrees of freedom and their directions.

Let f_d be a unit vector, in the frame of reference $\mathcal{R}_0(\theta, x_0, y_0, z_0)$, along the direction of the force that is to be applied by the end-effector. The positional freedom, if any, of the constrained end-effector will therefore lie in the subspace orthogonal to f_d .

A convenient coordinate frame for the description of tasks involving constrained motion operations is a coordinate frame $\mathcal{R}_f(\theta, x_f, y_f, z_f)$ obtained from \mathcal{R}_0 by a rotation transformation described by S_f such that z_f is aligned with f_d . For tasks where the freedom of motion (displacement) is restricted to a single direction orthogonal to f_d , one of the axes $\mathcal{O}x_f$ or $\mathcal{O}y_f$ will be selected in alignment with that direction, as shown for the task in Fig. 2.

Let us define, in the coordinate \mathcal{R}_f , the position specification matrix

$$\Sigma_f = \begin{pmatrix} \sigma_x & 0 & 0 \\ 0 & \sigma_y & 0 \\ 0 & 0 & \sigma_z \end{pmatrix} \quad (1)$$

where $\sigma_x, \sigma_y,$ and σ_z are binary numbers assigned the value 1 when a free motion is specified along the axes $\mathcal{O}x_f, \mathcal{O}y_f,$ and $\mathcal{O}z_f,$ respectively, and zero otherwise. A nonzero value of σ_z implies a full freedom of the end-effector position. This case of unconstrained end-effector position is integrated here for completeness. The coordinate frame \mathcal{R}_f in this case is assumed to be identical to \mathcal{R}_0 , and the matrix S_f is the identity matrix.

The directions of force control are described by the force specification matrix $\bar{\Sigma}_f$ associated with Σ_f and defined by

$$\bar{\Sigma}_f = I - \Sigma_f \quad (2)$$

where I designates the 3×3 identity matrix.

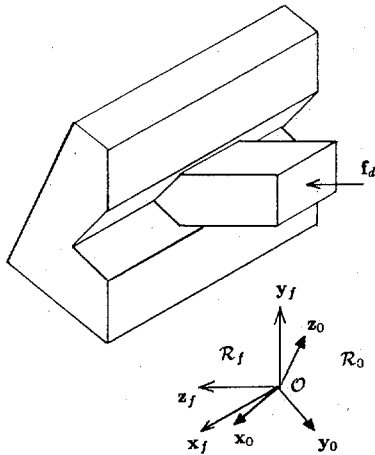

Fig. 2. One-degree-of-freedom motion.

Let us now consider the case where the end-effector task involves constrained rotations and applied moments. Let τ_d be the vector, in the frame of reference $\mathcal{R}_0(O, x_0, y_0, z_0)$, of moments that are to be applied by the end-effector, and $\mathcal{R}_\tau(O, x_\tau, y_\tau, z_\tau)$ be a coordinate frame obtained from $\mathcal{R}_0(O, x_0, y_0, z_0)$ by a rotation S_τ that brings z_τ into alignment with the moment vector τ_d . In \mathcal{R}_τ , the rotation freedom of the end-effector lies in the subspace spanned by $\{x_\tau, y_\tau\}$. To a task specified in terms of end-effector rotations and applied moments in the coordinate frame \mathcal{R}_τ , we associate the rotation and moment specification matrices Σ_τ and $\tilde{\Sigma}_\tau$, defined similarly to Σ_f and $\tilde{\Sigma}_f$.

For general tasks that involve end-effector motion (both position and orientation) and contact forces (forces and moments) described in the frame of reference \mathcal{R}_0 , we define the *generalized task specification matrices*

$$\Omega = \begin{pmatrix} S_f^T \Sigma_f S_f & 0 \\ 0 & S_\tau^T \Sigma_\tau S_\tau \end{pmatrix} \quad (3)$$

and

$$\tilde{\Omega} = \begin{pmatrix} S_f^T \tilde{\Sigma}_f S_f & 0 \\ 0 & S_\tau^T \tilde{\Sigma}_\tau S_\tau \end{pmatrix} \quad (4)$$

associated with specifications of motion and contact forces, respectively.

Ω and $\tilde{\Omega}$ act on vectors described in the reference frame \mathcal{R}_0 . A position command vector, for instance, initially expressed in \mathcal{R}_0 is transformed by the rotation matrix S_f to the task coordinate frame \mathcal{R}_f . The motion directions are then selected in this frame by the application of Σ_f . Finally, the resulting vector is transformed back in \mathcal{R}_0 by S_f^T .

The construction of the generalized task specification matrices is motivated by the aim of formulating the selection process in the same coordinate frame (reference frame \mathcal{R}_0) where the manipulator geometric, kinematic, and dynamic models are formulated. This allows a more efficient implementation of the control system for real-time operations. Control systems using specifications based only on the matrices Σ_f and Σ_τ will require costly geometric, kinematic, and dynamic transformations between the reference frame and the task coordinate frames.

The task specification matrices Ω and $\tilde{\Omega}$ can be constant, configuration-varying, or time-varying matrices. Nonconstant generalized task specification matrices correspond to specifications that involve changes in the direction of the applied force vector and/or moment vector, e.g., moving the end-effector while maintaining a normal force to a nonplanar surface. Ω and $\tilde{\Omega}$ have been expressed here with respect to the frame of reference \mathcal{R}_0 . For control systems implemented for tasks specified with respect to the end-effector coordinate frame, these matrices will be specified with respect to that coordinate frame as well.

III. END-EFFECTOR EQUATIONS OF MOTION

Joint space dynamic models, which establish the equations of manipulator joint motions, provide means for the analysis and control of these motions, and for the description of the configuration dependency and interactive nature of these mechanisms. However, the control of end-effector motion and contact forces, or the analysis and characterization of end-effector dynamic performance requires the construction of the model describing the dynamic behavior of this specific part of the manipulator system.

The end-effector motion is the result of those combined joint forces that are able to act along or about the axes of displacement or rotation of the end-effector. These are, indeed, the forces associated with the system of operational coordinates selected to describe the position and orientation of the end-effector. The construction of the end-effector dynamic model is achieved by expressing the relationships between its operational positions, velocities, accelerations, and the virtual operational forces acting on it.

First, let us consider the case of nonredundant manipulators, where a set of operational coordinates can be selected as a system of generalized coordinates for the manipulator. The manipulator configuration is represented by the column matrix q of n joint coordinates, and the end-effector position and orientation is described, in a frame of reference \mathcal{R}_0 , by the $m_0 \times 1$ column matrix x of independent configuration parameters, i.e., operational coordinates. With the manipulator nonredundancy assumption we have the equality $n = m_0$.

Now let us examine the conditions under which a set of independent end-effector configuration parameters can be used as a generalized coordinate system for a nonredundant manipulator. In the reference frame \mathcal{R}_0 , the system of m_0 equations expressing the components of x as functions of joint coordinates, i.e., the geometric model, is given by

$$x = G(q). \quad (5)$$

Let q_i and \bar{q}_i be, respectively, the minimal and maximal bounds of the i th joint coordinate q_i . The manipulator configuration represented by the point q in joint space is confined to the hyperparallelepiped

$$\mathcal{D}_q = \prod_{i=1}^n [q_i, \bar{q}_i]. \quad (6)$$

Obviously, for arbitrary kinematic linkages, and general joint boundaries, the set of functions G defined from \mathcal{D}_q to the

domain \mathcal{D}_x of the operational space given by

$$\mathcal{D}_x = \mathbf{G}(\mathcal{D}_q) \quad (7)$$

is not one-to-one.

Different configurations of the manipulator links can, in fact, be found for a given configuration of the end-effector. The restriction to a domain where \mathbf{G} is one-to-one is therefore necessary to construct, with the operational coordinates, a system of generalized coordinates for the manipulator mechanism.

In addition, for some configurations of the manipulator, the end-effector motion is restricted by the linkage constraints and its freedom of motion locally decreases. These are the singular configurations, which can be found by considering the differentiability characteristics of the geometric model \mathbf{G} . Singular configurations $\mathbf{q} \in \mathcal{D}_q$ are those where the Jacobian matrix $\mathbf{J}(\mathbf{q})$ involved in the variational or kinematic model associated with \mathbf{G} ,

$$\delta \mathbf{x} = \mathbf{J}(\mathbf{q})\delta \mathbf{q}, \quad (8)$$

is singular. The end-effector behavior at singular configurations is treated in Section VIII.

Let $\tilde{\mathcal{D}}_q$ be the domain obtained from \mathcal{D}_q by excluding the manipulator singular configurations and such that the vector function \mathbf{G} of (5) is one-to-one. Let $\tilde{\mathcal{D}}_x$ designate the domain

$$\tilde{\mathcal{D}}_x = \mathbf{G}(\tilde{\mathcal{D}}_q). \quad (9)$$

The independent parameters x_1, x_2, \dots, x_{m_0} form a complete set of configuration parameters for a nonredundant manipulator, in the domain $\tilde{\mathcal{D}}_x$ of operational space and thus constitute a system of generalized coordinates for the manipulator system.

The kinetic energy of the holonomic articulated mechanism is a quadratic form of the generalized operational velocities

$$T(\mathbf{x}, \dot{\mathbf{x}}) = \frac{1}{2} \dot{\mathbf{x}}^T \Lambda(\mathbf{x}) \dot{\mathbf{x}} \quad (10)$$

where $\Lambda(\mathbf{x})$ designates the $m_0 \times m_0$ symmetric matrix of the quadratic form, i.e., the kinetic energy matrix. Using the Lagrangian formalism, the end-effector equations of motion are given by

$$\frac{d}{dt} \left(\frac{\partial L}{\partial \dot{\mathbf{x}}} \right) - \frac{\partial L}{\partial \mathbf{x}} = \mathbf{F} \quad (11)$$

where the Lagrangian $L(\mathbf{x}, \dot{\mathbf{x}})$ is

$$L(\mathbf{x}, \dot{\mathbf{x}}) = T(\mathbf{x}, \dot{\mathbf{x}}) - U(\mathbf{x}) \quad (12)$$

and $U(\mathbf{x})$ represents the potential energy due to gravity. \mathbf{F} is the operational force vector. Let $\mathbf{p}(\mathbf{x})$ be the vector of gravity forces

$$\mathbf{p}(\mathbf{x}) = \nabla U(\mathbf{x}). \quad (13)$$

The end-effector equations of motion in operational space can be written [13], [14] in the form

$$\Lambda(\mathbf{x})\ddot{\mathbf{x}} + \mu(\mathbf{x}, \dot{\mathbf{x}}) + \mathbf{p}(\mathbf{x}) = \mathbf{F} \quad (14)$$

where $\mu(\mathbf{x}, \dot{\mathbf{x}})$ is the vector of end-effector centrifugal and Coriolis forces given by

$$\mu_i(\mathbf{x}, \dot{\mathbf{x}}) = \dot{\mathbf{x}}^T \Pi_i(\mathbf{x}) \dot{\mathbf{x}}, \quad i = 1, \dots, m_0. \quad (15)$$

The components of the $m_0 \times m_0$ matrices $\Pi_i(\mathbf{x})$ are the Christoffel symbols $\pi_{i,jk}$ given as a function of the partial derivatives of $\Lambda(\mathbf{x})$ with respect to the generalized coordinates \mathbf{x} by

$$\pi_{i,jk} = \frac{1}{2} \left(\frac{\partial \lambda_{ij}}{\partial x_k} + \frac{\partial \lambda_{ik}}{\partial x_j} - \frac{\partial \lambda_{jk}}{\partial x_i} \right). \quad (16)$$

The equations of motion (14) establish the relationships between positions, velocities, and accelerations of the end-effector and the generalized operational forces acting on it. The dynamic parameters in these equations are related to the parameters involved in the manipulator joint space dynamic model. The manipulator equations of motion in joint space are given by

$$\mathbf{A}(\mathbf{q})\ddot{\mathbf{q}} + \mathbf{b}(\mathbf{q}, \dot{\mathbf{q}}) + \mathbf{g}(\mathbf{q}) = \mathbf{\Gamma} \quad (17)$$

where $\mathbf{b}(\mathbf{q}, \dot{\mathbf{q}})$, $\mathbf{g}(\mathbf{q})$, and $\mathbf{\Gamma}$ represent, respectively, the Coriolis and centrifugal, gravity, and generalized forces in joint space. $\mathbf{A}(\mathbf{q})$ is the $n \times n$ joint space kinetic energy matrix. The relationship between the kinetic energy matrices $\mathbf{A}(\mathbf{q})$ and $\Lambda(\mathbf{x})$ corresponding, respectively, to the joint space and operational space dynamic models can be established [13], [14] by exploiting the identity between the expressions of the quadratic forms of the mechanism kinetic energy with respect to the generalized joint and operational velocities,

$$\Lambda(\mathbf{x}) = \mathbf{J}^{-T}(\mathbf{q})\mathbf{A}(\mathbf{q})\mathbf{J}^{-1}(\mathbf{q}). \quad (18)$$

The relationship between the centrifugal and Coriolis forces $\mathbf{b}(\mathbf{q}, \dot{\mathbf{q}})$ and $\mu(\mathbf{x}, \dot{\mathbf{x}})$ can be established by the expansion of the expression of $\mu(\mathbf{x}, \dot{\mathbf{x}})$ that results from (11),

$$\mu(\mathbf{x}, \dot{\mathbf{x}}) = \dot{\Lambda}(\mathbf{x})\dot{\mathbf{x}} - \nabla T(\mathbf{x}, \dot{\mathbf{x}}). \quad (19)$$

Using the expression of $\Lambda(\mathbf{x})$ in (18), the components of $\mu(\mathbf{x}, \dot{\mathbf{x}})$ in (19) can be written as

$$\begin{aligned} \dot{\Lambda}(\mathbf{x})\dot{\mathbf{x}} &= \mathbf{J}^{-T}(\mathbf{q})\dot{\mathbf{A}}(\mathbf{q})\dot{\mathbf{q}} - \Lambda(\mathbf{q})\mathbf{h}(\mathbf{q}, \dot{\mathbf{q}}) + \mathbf{J}^{-T}(\mathbf{q})\mathbf{A}(\mathbf{q})\dot{\mathbf{q}} \\ \nabla T(\mathbf{x}, \dot{\mathbf{x}}) &= \mathbf{J}^{-T}(\mathbf{q})\mathbf{l}(\mathbf{q}, \dot{\mathbf{q}}) + \mathbf{J}^{-T}(\mathbf{q})\mathbf{A}(\mathbf{q})\dot{\mathbf{q}} \end{aligned} \quad (20)$$

where

$$\mathbf{h}(\mathbf{q}, \dot{\mathbf{q}}) = \dot{\mathbf{J}}(\mathbf{q})\dot{\mathbf{q}} \quad (21)$$

and

$$l_i(\mathbf{q}, \dot{\mathbf{q}}) = \frac{1}{2} \dot{\mathbf{q}}^T \mathbf{A}_{q_i}(\mathbf{q})\dot{\mathbf{q}}, \quad i = 1, \dots, n. \quad (22)$$

The subscript q_i indicates the partial derivative with respect to the i th joint coordinate. Observing from the definition of $\mathbf{b}(\mathbf{q}, \dot{\mathbf{q}})$ that

$$\mathbf{b}(\mathbf{q}, \dot{\mathbf{q}}) = \dot{\mathbf{A}}(\mathbf{q})\dot{\mathbf{q}} - \mathbf{l}(\mathbf{q}, \dot{\mathbf{q}}) \quad (23)$$

yields

$$\mu(\mathbf{x}, \dot{\mathbf{x}}) = J^{-T}(\mathbf{q})\mathbf{b}(\mathbf{q}, \dot{\mathbf{q}}) - \Lambda(\mathbf{q})\mathbf{h}(\mathbf{q}, \dot{\mathbf{q}}). \quad (24)$$

The relationship between the expressions of gravity forces can be obtained using the identity between the functions expressing the gravity potential energy in the two systems of generalized coordinates and the relationships between the partial derivatives with respect to these coordinates. Using the definition of the Jacobian matrix (8) yields

$$\mathbf{p}(\mathbf{x}) = J^{-T}(\mathbf{q})\mathbf{g}(\mathbf{q}). \quad (25)$$

In the foregoing relations, the components involved in the end-effector equations of motion (14), i.e., Λ , μ , \mathbf{p} , are expressed in terms of joint coordinates. This resolves the ambiguity in defining the configuration of the manipulator corresponding to a configuration of the end-effector in the domain \mathcal{D}_x of (7). With these expressions, the restriction to the domain $\bar{\mathcal{D}}_x$, where \mathbf{G} is one-to-one, then becomes unnecessary. Indeed, the domain of definition of the end-effector dynamic model of a nonredundant manipulator can be extended to the domain $\bar{\mathcal{D}}_x$ defined by

$$\bar{\mathcal{D}}_x = \mathbf{G}(\bar{\mathcal{D}}_q) \quad (26)$$

where $\bar{\mathcal{D}}_q$ is the domain resulting from \mathcal{D}_q of (6) by excluding the kinematic singular configurations.

Finally, let us establish the relationship between generalized forces, i.e., \mathbf{F} and Γ . Using (18), (24), and (25) the end-effector equations of motion (14) can be rewritten as

$$J^{-T}(\mathbf{q})[\mathbf{A}(\mathbf{q})\ddot{\mathbf{q}} + \mathbf{b}(\mathbf{q}, \dot{\mathbf{q}}) + \mathbf{g}(\mathbf{q})] = \mathbf{F}. \quad (27)$$

Substituting (17) yields

$$\Gamma = J^T(\mathbf{q})\mathbf{F} \quad (28)$$

which represents the fundamental relationship between operational and joint forces consistent with the end-effector and manipulator dynamic equations. This relationship is the basis for the actual control of manipulators in operational space.

IV. END-EFFECTOR MOTION CONTROL

The control of a manipulator in operational space is based on the selection of the generalized operational forces \mathbf{F} as a command vector. These forces are produced by submitting the manipulator to the corresponding joint forces Γ obtained from (28).

As with joint space control systems, the control in operational space can be developed using a variety of control techniques. In operational space control systems, however, errors, performance, dynamics, simplifications, characterizations, and controlled variables are directly related to manipulator tasks.

One of the most effective techniques for dealing with these highly nonlinear and strongly coupled systems is the *nonlinear dynamic decoupling approach* [36], [37], which fully exploits the knowledge of the dynamic model structure and parameters. Within this framework of control and at the level of the uncoupled system linear, nonlinear, robust [32], and adaptive [3] control structures can be implemented.

Nonlinear dynamic decoupling in operational space is obtained by the selection of the following control structure,

$$\mathbf{F} = \mathbf{F}_m + \mathbf{F}_{ccg} \quad (29)$$

with

$$\begin{aligned} \mathbf{F}_m &= \hat{\Lambda}(\mathbf{x})\mathbf{F}_m^* \\ \mathbf{F}_{ccg} &= \hat{\mu}(\mathbf{x}, \dot{\mathbf{x}}) + \hat{\mathbf{p}}(\mathbf{x}) \end{aligned} \quad (30)$$

where $\hat{\Lambda}(\mathbf{x})$, $\hat{\mu}(\mathbf{x}, \dot{\mathbf{x}})$, and $\hat{\mathbf{p}}(\mathbf{x})$ represent the estimates of $\Lambda(\mathbf{x})$, $\mu(\mathbf{x}, \dot{\mathbf{x}})$, and $\mathbf{p}(\mathbf{x})$. \mathbf{F}_m^* is the command vector of the decoupled end-effector. With a perfect nonlinear dynamic decoupling, the end-effector becomes equivalent to a *single unit mass* I_{m_0} , moving in the m_0 -dimensional space. To simplify the notations, the symbol $\hat{\cdot}$ will be dropped in the following development.

At the level of the decoupled end-effector, \mathbf{F}_m^* , various control structures can be selected. For tasks where the desired motion of the end-effector is specified, a linear dynamic behavior can be obtained by selecting

$$\mathbf{F}_m^* = I_{m_0}\ddot{\mathbf{x}}_d - k_p(\mathbf{x} - \mathbf{x}_d) - k_v(\dot{\mathbf{x}} - \dot{\mathbf{x}}_d) \quad (31)$$

where \mathbf{x}_d , $\dot{\mathbf{x}}_d$, and $\ddot{\mathbf{x}}_d$ are the desired position, velocity, and acceleration, respectively, of the end-effector. I_{m_0} is the $m_0 \times m_0$ identity matrix. k_p and k_v are the position and velocity gain matrices.

An interesting approach for tasks that involve large motion to a goal position, where a particular path is not required, is based on the selection of the decoupled end-effector command vector \mathbf{F}_m^* as

$$\mathbf{F}_m^* = -k_v(\dot{\mathbf{x}} - \nu\dot{\mathbf{x}}_d) \quad (32)$$

where

$$\begin{aligned} \dot{\mathbf{x}}_d &= \frac{k_p}{k_v}(\mathbf{x}_d - \mathbf{x}) \\ \nu &= \min\left(1, \frac{V_{\max}}{\sqrt{\dot{\mathbf{x}}_d^T \dot{\mathbf{x}}_d}}\right). \end{aligned} \quad (33)$$

This allows a straight line motion of the end-effector at a given speed V_{\max} . The velocity vector $\dot{\mathbf{x}}$ is in fact controlled to be pointed toward the goal position while its magnitude is limited to V_{\max} . The end-effector will then travel at V_{\max} in a straight line, except during the acceleration and deceleration segments. This command vector is particularly useful when used in conjunction with the gradient of an artificial potential field for collision avoidance [15].

Using the relationship between generalized forces given in (28), the joint forces corresponding to the operational command vector \mathbf{F} , in (29) and (30), for the end-effector dynamic decoupling and control, can be written as

$$\Gamma = J^T(\mathbf{q})\Lambda(\mathbf{q})\mathbf{F}_m^* + \tilde{\mathbf{b}}(\mathbf{q}, \dot{\mathbf{q}}) + \mathbf{g}(\mathbf{q}) \quad (34)$$

where $\tilde{\mathbf{b}}(\mathbf{q}, \dot{\mathbf{q}})$ is the vector of joint forces under the mapping into joint space of the end-effector Coriolis and centrifugal

force vector $\mu(x, \dot{x})$. To simplify the notation, Λ has also been used here to designate the kinetic energy matrix when expressed as a function of the joint coordinate vector q . $\tilde{b}(q, \dot{q})$ is distinct from the vector of centrifugal and Coriolis forces $b(q, \dot{q})$ in (17) that arises when viewing the manipulator motion in joint space. These vectors are related by

$$\tilde{b}(q, \dot{q}) = b(q, \dot{q}) - J^T(q)\Lambda(q)h(q, \dot{q}). \quad (35)$$

A useful form of $\tilde{b}(q, \dot{q})$ for real-time control and dynamic analysis can be obtained by a separation of its dependency on position and velocity.

The joint space centrifugal and Coriolis force vector $b(q, \dot{q})$ of (17) can, in fact, be developed in the form

$$b(q, \dot{q}) = B(q)[\dot{q}\dot{q}] + C(q)[\dot{q}^2] \quad (36)$$

where $B(q)$ and $C(q)$ are, respectively, the $n \times n(n-1)/2$ and $n \times n$ matrices of the joint space Coriolis and centrifugal forces associated with $b(q, \dot{q})$. $[\dot{q}\dot{q}]$ and $[\dot{q}^2]$ are the symbolic notations for the $n(n-1)/2 \times 1$ and $n \times 1$ column matrices

$$\begin{aligned} [\dot{q}\dot{q}] &= [\dot{q}_1\dot{q}_2 \quad \dot{q}_1\dot{q}_3 \quad \cdots \quad \dot{q}_{n-1}\dot{q}_n]^T \\ [\dot{q}^2] &= [\dot{q}_1^2 \quad \dot{q}_2^2 \quad \cdots \quad \dot{q}_n^2]^T. \end{aligned} \quad (37)$$

With $[\dot{q}\dot{q}]$ and $[\dot{q}^2]$, the vector $h(q, \dot{q})$ can be developed in the form

$$h(q, \dot{q}) = H_1(q)[\dot{q}\dot{q}] + H_2(q)[\dot{q}^2] \quad (38)$$

where the matrices $H_1(q)$ and $H_2(q)$ have, respectively, the dimensions $n \times n(n-1)/2$ and $n \times n$. Finally, the vector $\tilde{b}(q, \dot{q})$ can be written as

$$\tilde{b}(q, \dot{q}) = \tilde{B}(q)[\dot{q}\dot{q}] + \tilde{C}(q)[\dot{q}^2] \quad (39)$$

where $\tilde{B}(q)$ and $\tilde{C}(q)$ are the $n \times n(n-1)/2$ and $n \times n$ matrices of the joint forces under the mapping into joint space of the end-effector Coriolis and centrifugal forces. These matrices are

$$\begin{aligned} \tilde{B}(q) &= B(q) - J^T(q)\Lambda(q)H_1(q) \\ \tilde{C}(q) &= C(q) - J^T(q)\Lambda(q)H_2(q) \end{aligned} \quad (40)$$

With the relation (39), the dynamic decoupling of the end-effector can be obtained using the configuration dependent dynamic coefficients $\Lambda(q)$, $\tilde{B}(q)$, $\tilde{C}(q)$, and $g(q)$. The joint force control vector (34) becomes

$$\Gamma = J^T(q)\Lambda(q)F_m^* + \tilde{B}(q)[\dot{q}\dot{q}] + \tilde{C}(q)[\dot{q}^2] + g(q). \quad (41)$$

By isolating these coefficients, end-effector dynamic decoupling and control can be achieved in a two-level control system architecture [15]. The real-time computation of these coefficients can then be paced by the rate of configuration changes, which is much lower than that of the mechanism dynamics. This leads to the following architecture for the control system

- a low rate *dynamic parameter evaluation level*: updating the end-effector dynamic parameters;
- a high rate *servo control level*: computing the command vector (41) using the updated dynamic coefficients.

This approach has also been proposed [10] for real-time dynamic control of manipulators in joint space.

V. CONSTRAINED MOTION OPERATIONS

The matrix Ω defined earlier specifies, with respect to the frame of reference \mathcal{R}_0 , the directions of motion (displacement and rotations) of the end-effector. Forces and moments are to be applied in or about directions that are orthogonal to these motion directions. These are specified by the matrix $\tilde{\Omega}$.

An important issue related to the specification of axes of rotation and applied moments is concerned with the compatibility between these specifications and the type of representation used for the description of the end-effector orientation. In fact, the specification of axes of rotations and applied moments in the matrices Σ_r and $\tilde{\Sigma}_r$ are only compatible with descriptions of the orientation using instantaneous angular rotations. However, instantaneous angular rotations are not quantities that can be used as a set of configuration parameters for the orientation. Representations of the end-effector orientation such as Euler angles, direction cosines, or Euler parameters, are indeed incompatible with specifications provided by Σ_r and $\tilde{\Sigma}_r$.

Instantaneous angular rotations have been used for the description of orientation error of the end-effector. An angular rotation error vector $\delta\phi$ that corresponds to the error between the actual orientation of the end-effector and its desired orientation can be formed from the orientation description given by the selected representation [13], [22].

The time derivatives of the parameters corresponding to a representation of the orientation are related simply to the angular velocity vector. With linear and angular velocities is associated the matrix $J_0(q)$, termed the *basic Jacobian*, defined independently of the particular set of parameters used to describe the end-effector configuration

$$\begin{pmatrix} v \\ \omega \end{pmatrix} = J_0(q)\dot{q}. \quad (42)$$

The Jacobian matrix $J(q)$ associated with a given representation of the end-effector orientation x_r can then be expressed in the form [13]

$$J(q) = E_{x_r}J_0(q) \quad (43)$$

where the matrix E_{x_r} is simply given as a function of x_r .

For end-effector motions specified in terms of Cartesian coordinates and instantaneous angular rotations, the dynamic decoupling and motion control of the end-effector can be achieved [13] by

$$\Gamma = J_0^T(q)\Lambda_0(x)F_m^* + \tilde{b}_0(q, \dot{q}) + g(q) \quad (44)$$

where $\Lambda_0(q)$ and $\tilde{b}_0(q, \dot{q})$ are defined similarly to $\Lambda(q)$ and $\tilde{b}(q, \dot{q})$ with $J(q)$ being replaced by $J_0(q)$.

Using the relationship (43) similar control structures can be designed to achieve dynamic decoupling and motion control with respect to descriptions using other representations for the orientation of the end-effector.

The unified operational command vector for end-effector dynamic decoupling, motion, and active force control can be

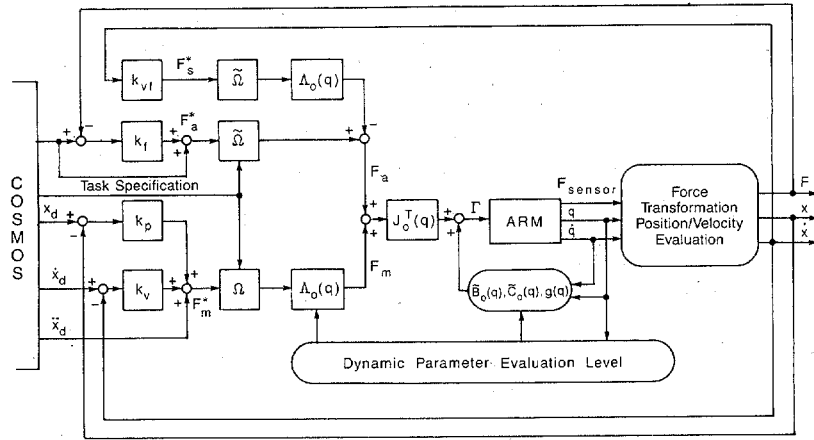

Fig. 3. Operational space control system architecture.

written as

$$F = F_m + F_a + F_{ccg} \quad (45)$$

where F_m , F_a , and F_{ccg} are the operational command vectors of motion, active force control, and centrifugal, Coriolis, and gravity forces given by

$$\begin{aligned} F_m &= \Lambda_0(q)\Omega F_m^* \\ F_a &= \tilde{\Omega} F_a^* + \Lambda_0(q)\tilde{\Omega} F_a^* \\ F_{ccg} &= \tilde{b}_0(q, \dot{q}) + g(q) \end{aligned} \quad (46)$$

where F_s^* represents the vector of end-effector velocity damping that acts in the direction of force control. The joint force vector corresponding to F in (45) is

$$\Gamma = J_0^T(q)[\Lambda_0(q)(\Omega F_m^* + \tilde{\Omega} F_s^*) + \tilde{\Omega} F_a^*] + \tilde{b}_0(q, \dot{q}) + g(q). \quad (47)$$

The control system architecture is shown in Fig. 3, where k_f represents the force error gain and k_{vf} denotes the velocity gain in F_s^* . An effective strategy for the control of the end-effector during the transition from free to constrained motions is based on a pure dissipation of the energy at the impact. The operational command vector F_a during the *impact transition control* stage is

$$F_a = \Lambda_0(q)\tilde{\Omega} F_s^*. \quad (48)$$

The duration of the impact transition control is a function of the impact velocity and the limitations on damping gains and actuator torques (this duration is typically on the order of tens of milliseconds). Force rate feedback has also been used in F_s^* . A more detailed description of the components involved in this control system, real-time implementation issues, and experimental results can be found in [19].

VI. REDUNDANT MANIPULATORS

The configuration of a redundant manipulator cannot be specified by a set of parameters that only describes the end-effector position and orientation. An independent set of end-effector configuration parameters, therefore, does not constitute a generalized coordinate system for a redundant

manipulator, and the dynamic behavior of the entire redundant system cannot be represented by a dynamic model in coordinates only of the end-effector configuration. The dynamic behavior of the end-effector itself, nevertheless, can still be described, and its equations of motion in operational space can still be established.

The end-effector is affected by forces acting along or about the axes of its freedom of motion. These are the operational forces associated with the operational coordinates selected to describe its position and orientation. Let us consider the end-effector dynamic response to the application, on the end-effector, or an operational force vector F . In this case of redundant manipulator systems, the joint forces that can be used to produce a given operational force vector are not unique. The joint force vector

$$\Gamma = J^T(q)F \quad (28)$$

represents, in fact, one of these solutions.

The application of the joint forces (28) to the manipulator (17), and the use of the relation

$$\ddot{x} = J(q)\ddot{q} + h(q, \dot{q}) \quad (49)$$

allow us to establish [13] the equations of motion of the end-effector

$$\Lambda_r(q)\dot{x} + \mu_r(q, \dot{q}) + p_r(q) = F \quad (50)$$

where

$$\begin{aligned} \Lambda_r(q) &= [J(q)A^{-1}(q)J^T(q)]^{-1} \\ \mu_r(q, \dot{q}) &= \tilde{J}^T(q)b(q, \dot{q}) - \Lambda_r(q)h(q, \dot{q}) \\ p_r(q) &= \tilde{J}^T(q)g(q) \end{aligned} \quad (51)$$

and

$$\tilde{J}(q) = A^{-1}(q)J^T(q)\Lambda_r(q). \quad (52)$$

$\tilde{J}(q)$ is actually a generalized inverse of the Jacobian matrix corresponding to the solution that minimizes the manipulator's instantaneous kinetic energy.

Equation (50) describes the dynamic behavior of the end-effector when the manipulator is submitted to a generalized

joint force vector of the form (28). The $m \times m$ matrix $\Lambda_r(q)$ can be interpreted as a *pseudo-kinetic energy matrix* corresponding to the end-effector motion in operational space. $\mu_r(q, \dot{q})$ represents the centrifugal and Coriolis forces acting on the end-effector and $p_r(q)$ the gravity force vector.

The effect on the end-effector of the application of arbitrary joint forces, can be determined by (50) which can be rewritten as

$$\bar{J}^T(q)[A(q)\ddot{q} + b(q, \dot{q}) + g(q)] = F. \quad (53)$$

Substituting (17) yields

$$F = \bar{J}^T(q)\Gamma. \quad (54)$$

This relationship determines how the joint space dynamic forces are reflected at the level of the end-effector.

Lemma: The unconstrained end-effector (50) is subjected to the operational force F if and only if the manipulator (17) is submitted to the generalized joint force vector

$$\Gamma = J^T(q)F + [I_n - J^T(q)\bar{J}^T(q)]\Gamma_0 \quad (55)$$

where I_n is the $n \times n$ identity matrix, $\bar{J}(q)$ is the matrix given in (52) and Γ_0 is an arbitrary joint force vector.

When the applied forces Γ are of the form (55), it is straightforward from (54) to verify that the only forces acting on the end-effector are the operational forces F produced by the first term in the expression of Γ . Joint forces of the form $[I_n - J^T(q)\bar{J}^T(q)]\Gamma_0$ correspond in fact to a null operational force vector.

The uniqueness of (55) is essentially linked to the use of a generalized inverse $\bar{J}(q)$ that is consistent with the dynamic equations of the manipulator and end-effector. The form of the decomposition (55) itself is general. A joint force vector Γ can always be expressed in the form of (55).

Let $P(q)$ be a generalized inverse of $J(q)$, and let us submit the manipulator to the joint force vector

$$\Gamma = J^T(q)F + [I_n - J^T(q)P^T(q)]\Gamma_0. \quad (56)$$

If, for any Γ_0 , the end-effector is only subjected to F , (56) yields

$$J(q)A^{-1}(q) = [J(q)A^{-1}(q)J^T(q)]P^T(q) \quad (57)$$

which implies the equivalence of $P(q)$ and $\bar{J}(q)$.

VII. CONTROL OF REDUNDANT MANIPULATORS

As in the case of nonredundant manipulators, the dynamic decoupling and control of the end-effector can be achieved by selecting an operational command vector of the form of (29), (30). The corresponding joint forces are

$$\Gamma = J^T(q)\Lambda_r(q)F_m^* + \bar{b}_r(q, \dot{q}) + g(q) \quad (58)$$

where $\bar{b}_r(q, \dot{q})$ is defined similarly to $\bar{b}(q, \dot{q})$.

The manipulator joint motions produced by this command vector are those that minimize the instantaneous kinetic energy of the mechanism.

Stability Analysis

In the command vector (58), and with the assumption of a "perfect" compensation (or noncompensation) of the centrifugal and Coriolis forces, the manipulator can be considered as a conservative system subjected to the dissipative forces due to the velocity damping term $(-k_v\dot{x})$ in F_m^* . These forces are

$$\Gamma_{\text{dis}} = D(q)\dot{q} \quad (59)$$

with

$$D(q) = -k_v J^T(q)\Lambda_r(q)J(q). \quad (60)$$

Lyapunov stability analysis leads to the condition

$$\dot{q}^T D(q)\dot{q} \leq 0 \quad (61)$$

which is satisfied, since $D(q)$ is an $n \times n$ negative semidefinite matrix of rank m . However, the redundant mechanism can still describe movements that are solutions of the equation

$$\dot{q}^T D(q)\dot{q} = 0. \quad (62)$$

An example of such behavior is shown in Fig. 4(a). The end-effector of a simulated three-degree-of-freedom planar manipulator is controlled under (58). The end-effector goal position coincides with its current position, while the three joints are assumed to have initially nonzero velocities (0.5 rad/s has been used).

Asymptotic stabilization of the system can be achieved by the addition of dissipative joint forces [13]. These forces can be selected to act in the null space of the Jacobian matrix [16]. This precludes any effect of the additional forces on the end-effector and maintains its dynamic decoupling. Using (55) these additional stabilizing joint forces are of the form

$$\Gamma_{ns} = [I_n - J^T(q)\bar{J}^T(q)]\Gamma_s. \quad (63)$$

By selecting

$$\Gamma_s = -k_{vq}A(q)\dot{q}, \quad (64)$$

the vector Γ_{ns} becomes

$$\Gamma_{ns} = \Gamma_s + J^T(q)\Lambda_r(q)F_{rs} \quad (65)$$

with

$$F_{rs} = k_{vq}\dot{x}. \quad (66)$$

Finally, the joint force command vector can be written as

$$\Gamma = J^T(q)\Lambda_r(q)(F_m^* + F_{rs}) + \Gamma_s + \bar{b}_r(q, \dot{q}) + g(q). \quad (67)$$

Under this form, the evaluation of the generalized inverse of the Jacobian matrix is avoided. The matrix $D(q)$ corresponding to the new expression for the dissipative joint forces Γ_{dis} in the command vector (67) becomes

$$D(q) = -[(k_v - k_{vq})J^T(q)\Lambda_r(q)J(q) + k_{vq}A(q)]. \quad (68)$$

Now, the matrix $D(q)$ is negative definite and the system is asymptotically stable. Fig. 4(b) shows the effects of this

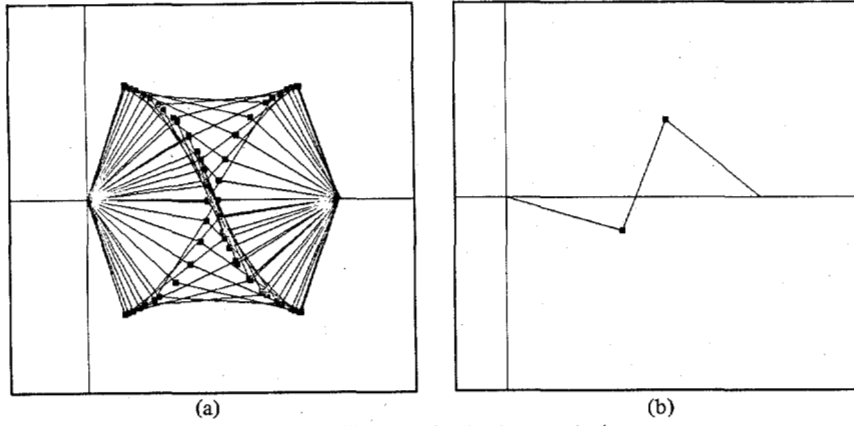

Fig. 4. Stabilization of redundant manipulator.

stabilization on the previous example of a simulated three-degree-of-freedom manipulator.

Constrained Motion Control

The extension to redundant manipulators of the results obtained in the case of nonredundancy is straightforward. The generalized joint forces command vector becomes

$$\Gamma = J_0^T(\mathbf{q})[\Lambda_{r0}(\mathbf{q})(\Omega \mathbf{F}_m^* + \tilde{\Omega} \mathbf{F}_s^* + \mathbf{F}_{rs}) + \tilde{\Omega} \mathbf{F}_a^*] + \Gamma_s + \tilde{\mathbf{b}}_{r0}(\mathbf{q}, \dot{\mathbf{q}}) + \mathbf{g}(\mathbf{q}) \quad (69)$$

where $\Lambda_{r0}(\mathbf{a})$ and $\tilde{\mathbf{b}}_{r0}(\mathbf{q}, \dot{\mathbf{q}})$ are defined with respect to the basic Jacobian matrix $J_0(\mathbf{q})$.

VII. SINGULAR CONFIGURATIONS

A *singular configuration* is a configuration \mathbf{q} at which some column vectors of the Jacobian matrix become linearly dependent. The mobility of the end-effector can be defined as the rank of this matrix [5]. In the case of nonredundant manipulators considered here, the end-effector at a singular configuration loses the ability to move along or rotate about some direction of the Cartesian space; its mobility locally decreases. Singularity and mobility can be characterized, in this case, by the determinant of the Jacobian matrix.

Singularities can be further specified by the posture of the mechanism at which they occur. Different types of singularities can be observed for a given mechanical linkage. These can be directly identified from the expression of the determinant of the Jacobian matrix. The expression of this determinant can, in fact, be developed into a product of terms, each of which corresponds to a type of singularity related to the kinematic configuration of the mechanism, e.g., alignment of two links or alignment of two joint axes.

To each singular configuration there corresponds a singular "direction." It is in this direction that the end-effector presents infinite inertial mass for displacements or infinite inertia for rotations. Its movements remain free in the subspace orthogonal to this direction. This behavior extends, in reality, to a neighborhood of the singular configuration. The extent of this neighborhood can be characterized by the particular expression $s(\mathbf{q})$ in the determinant of the Jacobian matrix that vanishes at this specific singularity. The neighbor-

hood of a given type of singularity \mathcal{D}_s can be defined as

$$\mathcal{D}_s = \{\mathbf{q} \mid |s(\mathbf{q})| \leq s_0\} \quad (70)$$

where s_0 is positive.

The basic concept in our approach to the problem of kinematic singularities can be formulated as follows. In the neighborhood \mathcal{D}_s of a singular configuration \mathbf{q} , the manipulator is treated as a mechanism that is redundant with respect to the motion of the end-effector in the subspace of operational space orthogonal to the singular direction. For end-effector motion in that subspace, the manipulator is controlled as a redundant mechanism. Joint forces selected from the associated null space are used for the control of the end-effector motion along the singular direction. When moving out of the singularity, this is achieved by controlling the rate of change of $s(\mathbf{q})$ according to the value of the desired velocity for this motion at the configuration when $|s(\mathbf{q})| = s_0$. Selecting the sign of the desired rate of change of $s(\mathbf{q})$ allows the control of the manipulator posture among the two configurations that it can generally take when moving out of a singularity. A position error term on $s(\mathbf{q})$ is used in the control vector for tasks that involve a motion toward goal positions located at or in the neighborhood of the singular configuration.

Using polar or singular value decomposition, this approach can be easily extended to redundant manipulator systems. The extension to configurations where more than one singularity is involved can be also simply achieved. An example of a simulated two-degree-of-freedom manipulator is shown in Fig. 5(a). The manipulator has been controlled to move into and out of the singular configuration while displaying two different postures. The time-response of the motion in the singular direction $x(t)$ is shown in Fig. 5(b).

IX. SUMMARY AND DISCUSSION

A methodology for the description of end-effector constrained motion tasks based on the construction of generalized task specification matrices has been proposed. For such tasks where both motion and active force control are involved, a unified approach for end-effector dynamic control within the operational space framework has been presented. The use of the generalized task specification matrix has provided a more

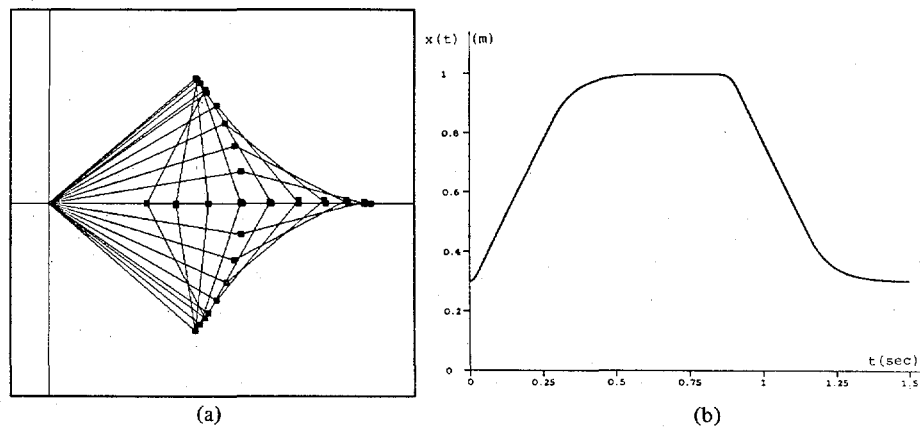

Fig. 5. Control at singular configuration.

efficient control structure for real-time implementations, further enhanced by a two-level control architecture.

Results of the implementation of this approach have shown the operational space formulation to be an effective means of achieving high dynamic performance in real-time motion control and active force control of robot manipulator systems. This approach has been implemented in an experimental manipulator programming system COSMOS (Control in Operational Space of a Manipulator-with-Obstacles System). Using a PUMA 560 and wrist and finger sensing, basic assembly operations have been performed. These include contact, slide, insertion, and compliance operations [17]. With the recent implementation of COSMOS in the multiprocessor computer system NYMPH [2], where four National Semiconductor 32016 microprocessors have been used, a low-level servo rate of 200 Hz and a high-level dynamics rate of 100 Hz have been achieved.

The impact transition control strategy was effective in the elimination of bounces at contact with a highly stiff surface. The end-effector normal velocities at impact were up to 4.0 in/s. Experiments with square wave force input have also been conducted, and responses with rise times of less than 0.02 s and steady force errors of less than 12 percent have been observed. This performance has been obtained despite the limitations in controlling the manipulator joint torques [27]. Accurate identification of the PUMA 560 dynamic parameters [1] has contributed to a nearly perfect dynamic decoupling of the end-effector.

For redundant manipulator systems, the end-effector equations of motion have been established, and an operational space control system for end-effector dynamic decoupling and control has been designed. The expression of joint forces of the null space of the Jacobian matrix consistent with the end-effector dynamic behavior has been identified and used for the asymptotic stabilization of the redundant mechanism. The resulting control system avoids the explicit evaluation of any generalized inverse or pseudo-inverse of the Jacobian matrix. Joint constraints, collision avoidance [12], [15], and control of manipulators' postures can be naturally integrated in this framework of operational space control systems. Also, a new systematic solution to the problem of kinematic singularities has been presented. This solution constitutes an effective

alternative to resolving end-effector motions into joint motions generally used in joint space based control systems.

ACKNOWLEDGMENTS

The author would like to thank Brian Armstrong, Harlyn Baker, Joel Burdick, Bradley Chen, John Craig, Ron Fearing, Jean Ponce, and Shashank Shekhar for the discussions, comments, and help during the preparation of the manuscript.

REFERENCES

- [1] B. Armstrong, O. Khatib, and J. Burdick, "The explicit dynamic model and inertial parameters of the PUMA 560 arm," in *Proc. 1986 IEEE Int. Conf. Robotics and Automation*, pp. 510-518.
- [2] B. Chen, R. Fearing, B. Armstrong, and J. Burdick, "NYMPH: A multiprocessor for manipulation applications," in *Proc. 1986 IEEE Int. Conf. Robotics and Automation*, pp. 1731-1736.
- [3] J. J. Craig, P. Hsu, S. S. Sastry, "Adaptive control of mechanical manipulators," in *Proc. 1986 IEEE Int. Conf. Robotics and Automation*, pp. 190-195.
- [4] B. Espiau and R. Boulic, "Collision avoidance for redundant robots with proximity sensors," in *Preprints 3rd Int. Symp. Robotics Research*, 1985, pp. 94-102.
- [5] A. Fournier, "Génération de mouvements en robotique—application des inverses généralisées et des pseudo inverses," Thèse d'état, Mention Science, Univ. des Sciences et Techniques du Languedoc, Montpellier, France, Apr. 1980.
- [6] H. Hanafusa, T. Yoshikawa, and Y. Nakamura, "Analysis and control of articulated robot arms with redundancy," in *Proc. 8th IFAC World Congress*, vol. XIV, 1981, pp. 38-83.
- [7] J. R. Hewit and J. Padovan, "Decoupled feedback control of a robot and manipulator arms," in *Proc. 3rd CISM-IFTOMM Symp. Theory and Practice of Robots and Manipulators*. New York: Elsevier, 1979, pp. 251-266.
- [8] J. M. Hollerbach and K. C. Suh, "Redundancy resolution of manipulators through torque optimization," in *Proc. 1985 Int. Conf. Robotics and Automation*, pp. 1016-1021.
- [9] N. Hogan, "Impedance control of a robotic manipulator," presented at the Winter Annual Meeting of the ASME, Washington, DC, 1981.
- [10] A. Izaguirre, and R. P. Paul, "Computation of the inertial and gravitational coefficients of the dynamic equations for a robot manipulator with a load," in *Proc. 1985 Int. Conf. Robotics and Automation*, pp. 1024-1032.
- [11] O. Khatib, M. Llibre, and R. Mampey, "Fonction décision-commande d'un robot manipulateur," Rapport Scientifique 2/7156, DERA-CERT, Toulouse, France, July 1978.
- [12] O. Khatib and J. F. Le Maitre, "Dynamic control of manipulators operating in a complex environment," in *Proc. 3rd CISM-IFTOMM Symp. Theory and Practice of Robots and Manipulators*. New York: Elsevier, 1979, pp. 267-282.
- [13] O. Khatib, "Commande dynamique dans l'espace opérationnel des robots manipulateurs en présence d'obstacles," thèse de doctorat-ingénieur, École Nationale Supérieure de l'Aéronautique et de l'Espace (ENSAE). Toulouse, France, 1980.

- [14] —, "Dynamic control of manipulators in operational space," in *Proc. 6th CISM-IFTOMM Congress on Theory of Machines and Mechanisms*. New York: Wiley, 1983, pp. 1128-1131.
- [15] —, "Real-time obstacle avoidance for manipulators and mobile robots," in *Proc. IEEE Int. Conf. Robotics and Automation*, pp. 500-505.
- [16] —, "Operational space formulation in the analysis, design, and control of manipulators," in *Preprints 3rd Int. Symp. Robotics Research*, 1985, pp. 103-110.
- [17] O. Khatib, J. Burdick, and B. Armstrong, "Robotics in three acts—Part II" (film), Artificial Intell. Lab., Stanford Univ., Stanford, CA, 1985.
- [18] O. Khatib and J. Burdick, "Dynamic optimization in manipulator design: The operational space formulation," presented at the 1985 ASME Winter Annual Meeting, Miami, FL.
- [19] —, "Motion and force control of robot manipulators," in *Proc. 1986 IEEE Int. Conf. Robotics and Automation*, pp. 1381-1386.
- [20] M. Kircanski and M. Vukobratovic, "Trajectory planning for redundant manipulators in presence of obstacles," in *Preprints 5th CISM-IFTOMM Symp. Theory and Practice of Robots and Manipulators*, 1984, pp. 43-58.
- [21] A. Liegeois, "Automation supervisory control of the configuration and behavior of multibody mechanisms," *IEEE Trans. Syst., Man, Cybern.*, vol. SMC-7, Dec. 1977.
- [22] J. Y. S. Luh, M. W. Walker, and P. Paul, "Resolved acceleration control of mechanical manipulators," *IEEE Trans. Automat. Contr.*, pp. 468-474, June 1980.
- [23] J. Y. S. Luh and Y. L. Gu, "Industrial robots with seven joints," in *Proc. 1985 IEEE Int. Conf. Robotics and Automation*, pp. 1010-1015.
- [24] M. T. Mason, "Compliance and force control for computer controlled manipulators," *IEEE Trans. Syst., Man, Cybern.*, vol. SMC-11, pp. 418-432, 1981.
- [25] Y. Nakamura, "Kinematical studies on the trajectory control of robot manipulators," Ph.D. dissertation, Kyoto, Japan, June 1985.
- [26] R. P. Paul and B. Shimano, "Compliance and control," in *Proc. Joint Automatic Control Conf.*, pp. 694-699, July 1976.
- [27] L. Pfeiffer, O. Khatib, and J. Hake, "Joint torque sensory feedback in the control of a PUMA manipulator," presented at the 1986 American Control Conf., Seattle, WA, June 1986.
- [28] M. Raibert and J. Craig, "Hybrid position/force control of manipulators," *ASME J. Dynamic Syst., Meas., Contr.*, June 1981.
- [29] M. Renaud, "Contribution à l'étude de la modélisation et de la commande des systèmes mécaniques articulés," thèse de docteur ingénieur, Univ. Paul Sabatier, Toulouse, France, Dec. 1975.
- [30] M. Renaud and J. Zabala-Iturralde, "Robot manipulator control," in *Proc. 9th Int. Symp. Industrial Robots*, 1979, pp. 463-475.
- [31] J. K. Salisbury, "Active stiffness control of a manipulator in Cartesian coordinates," presented at the 19th IEEE Conf. Decision and Control, Albuquerque, NM, Dec. 1980.
- [32] J. J. Slotine and O. Khatib, "Robust control in operational space for goal positioned manipulator tasks," presented at the 1986 American Control Conf., Seattle, WA, June 1986.
- [33] K. Takase, "Task-oriented variable control of manipulator and its software servoing system," in *Proc. IFAC Int. Symp.*, 1977, pp. 139-145.
- [34] D. E. Whitney, "Resolved motion rate control of manipulators and human prostheses," *IEEE Trans. Man-Machine Syst.*, vol. MMS-2, pp. 47-53, June 1969.
- [35] D. E. Whitney, "Force feedback control of manipulator fine motions," *ASME J. Dynamic Syst., Meas., Contr.*, pp. 91-97, June 1977.
- [36] J. Zabala-Iturralde, "Commande des robots manipulateurs à partir de la modélisation de leur dynamique," thèse de 3^{ème} cycle, Univ. Paul Sabatier, Toulouse, France, July 1978.
- [37] E. Freund, "The structure of decoupled nonlinear systems," *Int. J. Contr.*, vol. 21, no. 3, pp. 443-450, 1975.

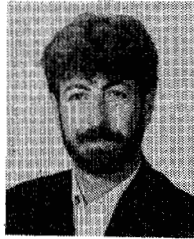

Oussama Khatib (M'85) received the degree of Docteur-Ingénieur en Automatique et Système from l'École Nationale Supérieure de l'Aéronautique et de l'Espace, Toulouse, France, in 1980.

He is a Senior Research Associate at the Artificial Intelligence Laboratory, Stanford University. He has worked in the field of robotics since 1976, when he joined le Centre d'Étude et de Recherche de Toulouse. There, he developed the foundation of the operational space formulation and the artificial potential field concept for robot manipulator control and collision avoidance. Since 1981, his research at Stanford University has been aimed at extending these methodologies to establish a unified framework for motion and active force control of robot manipulators operating in a cluttered and evolving environment. His research interests include issues of task description, constrained motion and force control, force strategies, redundancy, kinematic singularities, real-time obstacle avoidance, sensor fusion, and high-level programming systems. He is also concerned with the analysis and design of high-performance force-controlled robot manipulator and micro-manipulator systems.