



OFFICIAL LOCAL CARGO RULES TARIFF

All rules, rates and charges shown in this publication for UNITED CARGO are for informational purposes only, and are subject to change without notice.

All rates and charges are stated as airport-to airport rates and do not include tax.

For additional information and specific details, call or visit any UNITED CARGO office.

INDEX

General Transportation Rules and Regulations

G2	APPLICATION OF TARIFF.....	4
G4	DEFINITIONS	4
G6	DISPOSITION OF FRACTION	4
G8	COMPUTATION OF DAYS.....	4
G10	DESCRIPTION OF SHIPMENTS	4
G12	PACKAGING AND MARKING	4
G14	ADVANCE ARRANGEMENTS	5
G16	SHIPMENTS NOT ACCEPTABLE	5
G17	ACCEPTANCE AND CARRIAGE OF PERISHABLE SHIPMENTS.....	5
G18	ACCEPTANCE AND CARRIAGE OF LIVE ANIMALS	6
G19	ACCEPTANCE AND CARRIAGE OF SEAFOOD.....	6
G20	ACCEPTANCE OF ARTICLES OF EXTRAORDINARY VALUE	8
G22	ACCEPTANCE OF DANGEROUS GOODS.....	10
G24	ACCEPTANCE OF HUMAN REMAINS.....	10
G26	ACCEPTANCE OF SHIPMENTS REQUIRING SPECIAL DEVICES.....	10
G27	ACCEPTANCE OF NON-SECURITY SCREENED (non-CCSF) CARGO	10
G28	INSPECTION OF SHIPMENTS.....	11
G30	AIR WAYBILL	11
G32	U.S. GOVERNMENT SHIPMENTS.....	11
G34	COMPLIANCE WITH GOVERNMENT REQUIREMENTS	11
G36	LIABILITY OF UNITED	11
G38	CHARGES FOR DECLARED VALUE	11
G40	RESPONSIBILITY FOR CHARGES.....	11
G42	LIABILITY FOR UNPAID CHARGES	11
G46	ROUTING AND REROUTING.....	12
G50	AVAILABILITY OF EQUIPMENT AND SPACE.....	12
G52	APPLICATION OF RATES AND CHARGES.....	12
G54	CHARGEABLE WEIGHT PER SHIPMENT.....	13
G56	CHARGES ON MIXED SHIPMENTS	13
G58	CHARGES PREPAID OR COLLECT.....	13
G60	PAYMENT OF CHARGES.....	13
G62	CLAIM PROCEDURE.....	14
G64	INTERLINE SHIPMENTS – JOINT CARRIERS’ LIABILITY	14
S74	IMPORT/TRANSIT/EXPORT REGULATIONS – TERMINAL SERVICE CHARGES USA	15
S75	SECURITY SCREENING FEE.....	17
S76	DOCUMENTATION CHARGES	17
S86	SHIPPER’S INSURANCE	17
S88	COPY OF AIR WAYBILL REQUEST.....	17
R1	GOVERNING TARIFFS	18
R2	APPLICATION OF RATES.....	18
R6	MINIMUM CHARGE PER SHIPMENT	18

UNITED AIR LINES, INC.

R8	CHARGES FOR SHIPMENTS WITH SPECIAL TIE-DOWN REQUIREMENTS.....	18
R20	FURNISHING OF CONTAINERS.....	18
R22	CONTAINER DEFINITIONS	19
R24	CONTAINER SPECIFICATIONS	20
R26	APPLICATION OF CONTAINER CHARGES.....	23
R28	COMMODITY RESTRICTIONS	23
R32	LIABILITY FOR CONTAINERS	24
R34	RETURN TRANSPORTATION OF EMPTY SHIPPER-OWNED CONTAINERS.....	24
R36	CONTAINERS WITH OUTSIDE PIECES.....	24
R38	CONTAINER LOADING AND UNLOADING.....	25
R50	DESCRIPTION OF GEN SERVICE.....	26
R52	CONDITIONS OF ACCEPTANCE	26
R58	RESTRICTION OF SERVICE	26
R60	DESCRIPTION OF QPK (SMALL PACKAGE) SERVICE	27
R62	APPLICATION OF QPK CHARGES.....	27
R64	AIRPORT-TO-AIRPORT SERVICE.....	27
R68	SERVICES NOT AVAILABLE	27
R70	CONDITIONS OF ACCEPTANCE	27
R72	SHIPMENTS NOT ACCEPTABLE	28
R74	DECLARED VALUE.....	28
R75	INSURANCE	28
R76	LIMITATION OF LIABILITY.....	28
R78	DISPOSITION OF UNCLAIMED SHIPMENTS.....	28
R80	REFUND FOR SERVICE FAILURE.....	28
R90	EXCEPTION RATING.....	30
R91	HUMAN REMAINS.....	30
R92	LIVE ANIMALS.....	30
R94	DESCRIPTION OF UNITED AIRLINES EXP SERVICE.....	31
R96	EXP CONDITIONS OF ACCEPTANCE.....	31
R98	EXP PERFORMANCE GUARANTEE	31

UNITED AIR LINES, INC.

SECTION I
GENERAL RULES AND REGULATIONS

RULE

G2 APPLICATION OF TARIFF

- (A) Rules, regulations and charges published herein apply only as follows:
 - (1) For transportation via United Airlines, Inc. (United and excluding United Express) between points served by UA within the U.S.A. and between points in the U.S.A.
- (B) Transportation is subject to the rules, regulations and charges in effect as published on www.unitedcargo.com on the date of acceptance of the shipment for transportation by the originating carrier.

G4 DEFINITIONS

- (A) Air Waybill: A non-negotiable document covering the contract between the shipper and UA.
- (B) Consignee: The person or company whose name appears on the air waybill as the party to whom the shipment is to be delivered.
- (C) Continental United States: The 48 contiguous states, Alaska and the District of Columbia.
- (D) Contiguous United States: The 48 adjacent states and the District of Columbia.
- (E) Legal Holiday: Any national, state or local legal holiday.
- (F) Seal: A fastening device, identifiable by letters, numbers or combinations of both used to secure the contents of a container or other unit of packaging and which device, when broken, will evidence opening of the container or package.
- (G) Shipment: A single consignment of one or more pieces, from one shipper, at one time, at one address, tendered to UA in one lot and moving on one air waybill to one consignee, at one destination address.
- (H) Shipper (or Consignee): The person or company whose name appears on the air waybill as the party contracting with UA for the carriage of the shipment.
- (I) U.S.A.: The 48 contiguous United States, District of Columbia, Alaska, Hawaii and Puerto Rico.

G6 DISPOSITION OF FRACTION

- (A) Fractions of a pound will be rounded up to the next higher pound.
- (B) In computing charges, fractions of less than one-half cent will be dropped and fractions of one-half cent or more will be rounded up to the next higher cent.
- (C) Before computing cubic dimensions, fractions of less than one-half inch will be dropped and fractions of one-half inch or more will be rounded up to the next higher inch.

G8 COMPUTATION OF DAYS

Full calendar days will be used, including Sundays and legal holidays.

Exception: When the last day falls on a Sunday or legal holiday, the next following calendar day (other than a Sunday or legal holiday) will be included.

G10 DESCRIPTION OF SHIPMENTS

The contents of a shipment must be accurately and specifically described on the air waybill. The number of pieces included in a shipment must be specified on the air waybill.

G12 PACKAGING AND MARKING

- (A) Shipments must be prepared or packaged to insure safe transportation with ordinary care in handling.
- (B) Any article susceptible to damage by ordinary handling or as a result of any condition which may be encountered in air transportation must be adequately protected by proper packing and bear appropriate labels or markings.
- (C) All shipments of articles and commodities which are susceptible to leakage must be packed by the shipper in solid, leak-proof boxes or inner containers, such as heavy polyvinyl bags.
- (D) Each piece must be legibly and durably marked with the name and address of the shipper and consignee.
- (E) Pieces with a weight in excess of the floor-bearing capacity of available aircraft must be provided with a suitable skid or base that will distribute the weight of the pieces so as not to exceed such aircraft capacity. The weight of the shipment must include the weight of the skid or base.
- (F) Cut flowers and nursery stock shipments must show the total cubic measurement on the exterior of all boxes.
- (G) Liquids or fragile or perishable articles must not be enclosed in the same package as wearing apparel.

UNITED AIR LINES, INC.

**SECTION I
GENERAL RULES AND REGULATIONS**

RULE

G12 PACKAGING AND MARKING (continued)

- (H) Packing, marking and labeling of hazardous materials/dangerous goods must comply with the Dangerous Goods Regulations issued by International Air Transport Association (IATA).
- (I) Firearms must be packed in a manufacturer's crushproof container made specifically for the firearm(s), or in a hard case. Firearms must be unloaded for transportation.

G14 ADVANCE ARRANGEMENTS

The Shipper must contact United Cargo (Toll Free **1-800-UA-CARGO** or **1-800-822-2746**) to determine shipping requirements before tendering a shipment containing:

- (A) Articles of extraordinary value, dangerous goods, live animals, human remains
- (B) Articles liable to penetrate or otherwise damage equipment or other shipments
- (C) Pieces having a floor bearing weight exceeding 150 pounds per square foot
- (D) Shipments with accompanying attendant
- (E) Shipments requiring special handling or loading devices.

G16 SHIPMENTS NOT ACCEPTABLE

- (A) United will not accept
 - (1) Shipments which require United to obtain a Federal, State or local license for their transportation when United has elected not to comply with such license requirements.
 - (2) Shipments not accompanied by proper documentation and necessary information as required by any convention, law or government regulation.
 - (3) Poison or poisonous animals, as specified in Rule G18.
 - (4) Semen, except when shipped as QPK for carriage on United or United Express only (cannot be interlined with other carriers). The only acceptable forms of packaging are: Hamilton System Equitainer, Expecta Container, Bio-Flite Container, Equine Express II, MVE Cryoshipper and Plastilite Equine Semen Transporter. Interlining services are not available to/from other airlines with the exception of United Express.
 - (5) Embryos.
 - (6) Edible fish and seafood live or dead, fresh or frozen, exceeding 150 pounds per box, unless tendered in tuna shipping containers as described in the provisions of Rule G19 herein.
 - (7) Shipments containing some parts (but not all parts) moving under carrier's U.S. Customs Bond.
 - (8) Live birds
 - (9) Freight tendered in a shipper-built ULD container, on a ULD pallet, or multiple pieces shrink-wrapped and/or banded to skids **unless** the freight has been screened at a Certified Cargo Screening Facility (CCSF) before tender to United.
 - (10) Shipments of firearms or guns: United defines firearms or guns as objects capable, or appearing capable, of discharging a projectile by the action of an explosive and causing injury or death. Included in this category are parts or modifiers for firearms or guns. Ammunitions are also included in this category and are not acceptable.
- (B) United will not accept a shipment for transportation when it reasonably appears the shipment is:
 - (1) Improperly packed; or
 - (2) Of a kind or type likely to incur damage from high or low temperature, notwithstanding the ordinary care in handling such shipment by United when available facilities cannot protect the shipment against such conditions; or
 - (3) Of an inherent nature or defect which indicates that transportation could not be furnished without loss or damage to the shipment; or
 - (4) When required advance arrangements have not been satisfactorily completed.

G17 ACCEPTANCE AND CARRIAGE OF PERISHABLE SHIPMENTS

- (A) The following commodities are classified as perishable shipments:
 - Fruits / Vegetables – fresh or frozen
 - Seafood – live, fresh or frozen
 - Meat – fresh or frozen
 - Tropical fish, live
 - Animals, live
 - Live plants
 - Cut flowers and decorative greens
 - All other commodities or products where spoilage occurs within 48 hours when exposed to weather elements.

UNITED AIR LINES, INC.

SECTION I
GENERAL RULES AND REGULATIONS

RULE

G18 ACCEPTANCE AND CARRIAGE OF LIVE ANIMALS

- (A) United will accept specific species of live animals which can be safely transported on its equipment. Acceptance and transportation of live animals is subject to special conditions and government laws and regulations.

United Cargo will accept commercial (non-pet) shipments of the following live animals:

- Live fish (including tropical fish)
- Mice and other rodents for laboratory purposes
- Amphibians
- Insects (including bees)
- Day-old poultry and hatching eggs
- Live animals shipped as food for consumption (including crustaceans and shellfish)

United Cargo will **not** accept shipments of the following live animals:

- Birds (except day-old poultry and hatching eggs)
- Snakes and other reptiles
- Rabbits
- Sugar gliders
- Zoo animals
- Other warm-blooded animals (except as listed under "will accept" above.)

Exception: The following live animals are not acceptable for transportation via United:

- (1) Animals that are poisonous (including snakes), or
- (2) Poisonous insects, other than Queen Bees and their attendant bees.

- (B) Animal Crates
Animals crates are no longer available for sale or exchange by customers at United PetSafe acceptance facilities.

- (C) PetSafe
Effective July 30, 2018, United has resumed transport of cats and dogs via our PetSafe program. However, embargoes remain in place for all other species of household pets and animals and for certain short- or snub-nosed cat and dog breeds. Visit www.united.com/petsafe to view the complete list of embargoed breeds and other PetSafe program restrictions.

G19 ACCEPTANCE AND CARRIAGE OF SEAFOOD

(A) General Rules

- (1) Seafood must be tendered in durable, watertight packaging and packaged to withstand up to 48 hours domestic transit time and up to 72 hours international transit time.
- (2) Any shipment with evidence of leaking or strong odor will be refused.
- (3) Smoked fish individually vacuum-packed in plastic, without brine, is not subject to these seafood packaging rules. However, smoked fish shipments **are** subject to these rules whenever brine is present.

(B) Refrigerants

- (1) Gel packs or dry ice are the preferred refrigerants.
- (2) A shipper using wet ice as refrigerant **must** be pre-validated and comply with specific inner packaging, outer packaging, and ULD packaging requirements. Please contact United Cargo for additional information.
- (3) If dry ice is used, quantity and packaging must conform to IATA Dangerous Goods Regulations and the United Airlines Ramp Operations Manual.

UNITED AIR LINES, INC.

SECTION I
GENERAL RULES AND REGULATIONS

RULE

G19 ACCEPTANCE AND CARRIAGE OF SEAFOOD (continued)

(C) Outer Packaging

The following rules apply to shipping units (boxes, cartons, canisters, etc.) containing seafood:

- (1) Gross weight cannot exceed 150 pounds per unit.

Exception: Whole tuna shipping containers ("tuna coffins") may exceed 150 pounds per unit. Tuna coffins must meet or exceed design specifications defined by United. Prior approval by United Cargo is required.

- (2) Units tendered as bulk must be able to withstand stacking of fully loaded units to a height of 56 inches. Crushed, crumpled or damaged units will be refused.
- (3) Unit must have wax-impregnated or waterproof coating inside and outside.
- (4) Unit must have leak-proof construction with gusseted corners both top and bottom. Top must extend fully over bottom.
- (5) Unit must be banded with a minimum of two bands around the width of the unit.
- (6) All Styrofoam shipping units must be protected by an overpack consisting of a sturdy fiberboard container.

Exception: "Cloud Pack" or "Arctic Box" brand Styrofoam containers do not require a fiberboard overpack. Only these specific Styrofoam containers will be accepted without the fiberboard overpack.

- (7) Canisters or buckets with liquid contents must be leak-proof.

(D) Inner Packaging

- (1) A minimum 4-mil (or two 2-mil) plastic or polyethylene bag(s) or liner(s) must be used to line the inside of each seafood shipping unit.
- (2) Absorbent material must be placed between the liner and the inner bag containing the seafood to absorb any leaking or condensation.
- (3) The seafood must be completely sealed in one 4-mil (or two 2-mil) sturdy, puncture-resistant polyethylene bag(s). The inner bag must be heat-sealed or sealed by cable ties, wire, clips or bands. Whichever sealing method is used, the inner bag must be leak-proof even when tipped or inverted.

Exception: Inner bags of live seafood should never be sealed, as adequate air is necessary to ensure the viability of the product. Inner bags of live seafood must extend above the level of the seafood.

- (4) Crabs, halibut and all other fish with sharp claws, fins or projections must be packaged with a corrugated board liner inside the polyethylene bag that covers all sides and both top and bottom. Placement of the board liner must ensure that claws, fins or projections do not come into contact with the inner bag.

UNITED AIR LINES, INC.

SECTION I
GENERAL RULES AND REGULATIONS

RULE

G19 ACCEPTANCE AND CARRIAGE OF SEAFOOD (continued)

(E) Shipper-Loaded ULDs

Seafood shipments in shipper-loaded ULDs must be tendered to United unsealed and will only be accepted if pre-screened at a Certified Cargo Screening Facility (CCSF) before tender to United (see rule G27). United will seal each container after inspection of the contents. This inspection is to ensure that the following standards are met:

- (1) Units tendered in shipper-loaded ULDs must comply with the refrigerant, outer packaging and inner packaging rules above.
- (2) The ULD must be lined with a polyethylene or plastic liner, and absorbent material must be placed between the liner and the seafood units. Both the liner and the absorbent material must completely cover the bottom and partially cover the sides of the ULD. A combination plastic liner with embedded absorbent material may also be used to cover the bottom and partial sides of the ULD.
- (3) All units in the ULD must be loaded straight with the correct end up. No unit can be loaded in the ULD diagonally or on its side.
- (4) All units in the ULD must be able to withstand the weight of any stacking without buckling, crumpling, crushing or leaking. The ULD will be refused if any units are visibly damaged.

(F) Marking/Labeling

- (1) Each shipping unit must be marked with the name and phone number of the shipper and the name and address of the consignee.
- (2) The California Department of Fish and Game requires that all shipments of seafood contain markings indicating the species and the total weight of each species in the container.
- (3) Each seafood packaging unit must be clearly marked/labeled with:
 - (a) "Perishable – Fresh Seafood", "Perishable – Frozen Seafood" or "Perishable – Live Seafood" as applicable.
 - (b) "This Side Up" or ISO arrows clearly indicating upright position.

(G) Air Waybill

All air waybills accompanying seafood shipments must include:

- (1) 24-hour phone number for Shipper and Consignee
- (2) Number of pieces and gross weight
- (3) Description of shipment (fresh, frozen, or live; species of seafood)
- (4) Specific commodity number, if applicable
- (5) Established account number for credit shipments.

G20 ACCEPTANCE OF ARTICLES OF EXTRAORDINARY VALUE

- (A) High Value means any shipment where valuation coverage in excess of \$25,000 USD has been requested.
- (B) Articles of Extraordinary Value (AEV) – any shipment containing the following commodities, regardless of whether there is declared value for carriage:

UNITED AIR LINES, INC.

SECTION I
GENERAL RULES AND REGULATIONS

RULE

G20 ACCEPTANCE OF ARTICLES OF EXTRAORDINARY VALUE (continued)

1. Artwork or Watches (when the true value is in excess of \$1000.00 USD per pound or \$2,204.00 USD per kilo)
 2. Fur or Fur-trimmed Clothing
 3. Gems (Cut or uncut, including diamonds for industrial use)
 4. Jewelry (Other than costume jewelry)
 5. Negotiable Instruments (inclusive of blank credit cards, traveler's checks) such as bonds, coins, currency, deeds, evidence of debt, money, promissory notes, securities, and stock certificates
 6. Opals
 7. Pearls (real or cultured)
 8. Precious Metals in any form (liquid, grain, sheet, foil, powder, sponge, wire, rod, tube, circles, molding, castings, dust, sulfides, cyanides, concentrates, precipitates, bullion)
- (C) Packaging requirements:
- (1) High value shipments must be packed in sealed outer containers of at least one cubic foot and of sufficient strength to permit other freight to be stacked around and on top of the container, and have a minimum top-loading capability of 75 pounds per square foot.
 - (2) Articles of Extraordinary Value must be packed in sealed outside containers of wood or metal of at least one cubic foot. The seal numbers must be recorded on the air waybill.
 - (3) Articles of Extraordinary Value may not be included in the same shipment with any other articles, except when the shipment is tendered in a sealed container.
- (D) The following provisions apply to a shipment of Articles of Extraordinary Value:
- (1) Shipments will be accepted only at an airport area designated by United not more than three hours prior to the scheduled departure of the flight for which advance arrangements have been made; and
 - (2) Shipments will be accepted only if the consignee will accept delivery of the shipment at the destination airport within three hours after the scheduled flight arrival time.
 - (3) If shipment will not be available to the consignee within two hours after the scheduled arrival time, United will notify the consignee. If the consignee will not accept the shipment within three hours after the time of arrival, or if United is unable to contact the consignee, United will, at the shipper's expense:
 - (a) hire an armored vehicle, or, if the shipment cannot be accommodated in an armored vehicle, a vehicle with an armed guard to deliver the shipment to a public warehouse or other suitable repository for safekeeping subject to applicable U.S. Customs laws and regulations; and
 - (b) hire armed guard service to protect the shipment until the consignee accepts the shipment, or, until disposal of the shipment, whichever occurs first.
- (E) Booking requirements:
- (1) Articles of Extraordinary Value/AEV must be booked 24 hours in advance with the Customer Service Center.
- (F) United will notify the Shipper and Consignee at the addresses shown on the air waybill after the Shipment has been delivered to a suitable repository.
- (1) The terms and conditions of the air waybill and these Rules and Regulations shall extend to the armored vehicle or vehicle with an armed guard hired by United, and all resulting charges incurred by United must be paid by the Shipper or Consignee.
 - (2) The terms and conditions of the air waybill define United's limit of liability for shipments of Articles of Extraordinary Value.
 - (3) Shipments of Articles of Extraordinary Value must be tendered using EXP service.

UNITED AIR LINES, INC.

SECTION I
GENERAL RULES AND REGULATIONS

RULE

G22 ACCEPTANCE OF DANGEROUS GOODS

- (A) Shipments containing or consisting of dangerous goods will be accepted only if they comply with all applicable rules and provisions as published in Dangerous Goods Regulations issued by International Air Transport Association (IATA).
- (B) In addition to all other applicable transportation charges, a surcharge of \$85.00 shall apply to each different dangerous good (UN number) contained in a shipment as described in Paragraph (A) of this rule. The surcharge also applies to United's portion of joint transportation other than those Carriers whose rates appear in the United Cargo Official Local Cargo Rates Tariff as published on www.unitedcargo.com.
Exception: For shipments containing over 5 pounds of dry ice, a surcharge of \$25.00 per air waybill shall apply.
- (C) EXP guarantee is applicable for the following Dangerous Goods: Dry Ice, magnetized materials, Radioactive - Class 7, (with no transport index (T.I.), White label only, with Research Diagnostic Treatment). No other Dangerous Goods will be guaranteed.
- (D) Dangerous goods shipments can be shipped via GEN, EXP or QPK. QPK is limited to online UA only. Dangerous goods are generally accepted only at Air Freight facilities. Exception: Dry ice in quantities of 5 pounds or less will be accepted at most QPK counters.

G24 ACCEPTANCE OF HUMAN REMAINS

- (A) Human Remains must be accompanied by a certificate of physician or health care officer, or burial removal permit and/or transit permit, as required by State law.
- (B) Uncremated Human Remains must be adequately secured in a casket and packed in approved air tray packaging to prevent casket damage, shifting and the escape of offensive odors.
- (C) Remains not embalmed must be tendered in hermetically sealed caskets/air trays.
- (D) Cremated remains must be shipped in funeral urns that are sufficiently protected against breakage by a cushioned packaging. Cremated human remains must be tendered using United's QPK service.
- (E) Uncremated Human Remains Shipments must be tendered using EXP service.

G26 ACCEPTANCE OF SHIPMENTS REQUIRING SPECIAL DEVICES

Shipments requiring special devices for safe handling will be accepted only when these devices are provided and operated by the Shipper or Consignee at their risk. United must approve operation of such special device on United's premises. When, upon request, United provides special devices and an operator, the Shipper or Consignee must reimburse United for all charges incurred.

G27 ACCEPTANCE OF NON-SECURITY SCREENED (non-CCSF) CARGO

Acceptance Standards:

- (A) Freight Acceptance Times
 - (1) The acceptance time standard (cut-off time) for non-security screened (non-CCSF) GEN shipments tendered in DEN, IAD, LAX, ORD, EWR, IAH, and SFO is two (2) hours in addition to the time(s) specified under Rule R52 of this tariff.
 - (2) This additional time does not apply to EXP or QPK shipments.
- (B) Freight Packaging
 - (1) United Cargo will not accept freight (excluding live animals) tendered in the U.S. or Puerto Rico in a shipper-built ULD container, on a ULD pallet, or multiple piece shrink-wrapped and/or banded to skids unless the freight has been screened at a Certified Cargo Screening Facility (CCSF) before tender to United.
 - (2) Exception: United Cargo U.S. locations will accept unscreened multiple-piece shrink-wrapped and/or banded skids consisting of a single homogeneous commodity. To be considered "homogeneous," each piece on the skid must contain identical contents and must have similar packaging. Screening fees apply to the total actual weight of the shipment of homogeneous skid(s).
- (C) Labeling Requirements
 - (1) Each piece of any shipment tendered non-security screened (non-CCSF freight) must be individually labeled. This label must include the air waybill number, destination, and (if applicable) house air waybill information.

UNITED AIR LINES, INC.

**SECTION I
GENERAL RULES AND REGULATIONS**

RULE

G28 INSPECTION OF SHIPMENTS

- (A) All shipments are subject to inspection by United, but United shall not be obligated to perform such inspection.
- (B) Consignee may not inspect or examine the contents of any part of any package in the shipment prior to signing for receipt of the shipment on the delivery copy of the air waybill.
- (C) Containers of perishable articles or produce must be tendered to United unsealed. United will seal each container after inspection for compliance with United's packaging requirements.

G30 AIR WAYBILL

The Shipper must prepare and present an air waybill with each Shipment tendered for transportation. If the Shipper fails to present an air waybill, or presents an incomplete air waybill, United will prepare or complete the air waybill and the Shipper shall be bound by such air waybill.

G32 U.S. GOVERNMENT SHIPMENTS

Any shipment transported for the United States government must be accompanied by a Government Bill of Lading or Government Transportation Request.

G34 COMPLIANCE WITH GOVERNMENT REQUIREMENTS

- (A) The Shipper must comply with all laws and all government regulations applicable to the Shipment, and shall provide required documentation. United does not have to inquire into the correctness or sufficiency of documentation and shall not be liable for loss of expense due to Shipper's failure to comply with this provision.
- (B) United will not be liable if it refuses to carry a Shipment which, in United's judgment, would violate applicable laws or government regulations.

G36 LIABILITY OF UNITED

- (A) See "U.S. DOMESTIC CONTRACT OF CARRIAGE" on United's air waybill for provisions relating to liability of United.
- (B) Limitation of liability – United will not be liable for loss or damage to shipments which are likely to deteriorate or perish due to climate, temperature or exposure, except through the failure of United to exercise reasonable care.

G38 CHARGES FOR DECLARED VALUE

- (A) A shipment shall have a declared value of fifty cents per chargeable weight pound or, for shipments between the U.S. and Canada, \$9.07 per chargeable weight pound or \$20.00 per chargeable weight kilogram (but not less than \$50.00 per Shipment) unless the Shipper declares a higher value on the air waybill when tendered to United.
- (B) If a higher value is declared, an additional transportation charge will be assessed. The charge is 50 cents per \$100.00 or fraction thereof, by which the declared value exceeds 50 cents per chargeable weight pound or \$50.00 per shipment (or, for shipments between the U.S. and Canada, by which the declared value exceeds \$9.07 per chargeable weight pound or \$20.00 per chargeable weight kilogram).

G40 RESPONSIBILITY FOR CHARGES

The Shipper and Consignee shall be responsible, jointly and severally, to indemnify United for all claims, fines, penalties, damages, costs or other sums which may be incurred or paid by United for any violation of any of these rules and regulations and applicable government regulations, or any other default of the Shipper or other parties with respect to a shipment.

G42 LIABILITY FOR UNPAID CHARGES

- (A) The Shipper and Consignee are liable, jointly and severally, for all unpaid charges attached to a shipment including, but not confined to, sums advanced or disbursed by United on account of such Shipment.
Exceptions:
 - (1) The Shipper is not liable for any unpaid charges against a collect shipment where United has extended credit to the Consignee, unless the Shipper has guaranteed in writing the payment of the charges.
 - (2) The Consignee is not liable for any unpaid charges against a prepaid shipment where United has extended credit to the Shipper.

UNITED AIR LINES, INC.

**SECTION I
GENERAL RULES AND REGULATIONS**

RULE

- (B) United shall have a lien on the shipment for all sums due and payable. If the shipment cannot be delivered because of non-payment of any charges, United will hold the shipment, subject to applicable storage charges. United will notify the Shipper and Consignee that the shipment will be disposed of at public or private sale, unless United receives instructions, accompanied by payment.

G44 DISPOSITION OF SHIPMENT

- (A) If a non-perishable shipment is unclaimed within the free storage time, United will notify the Shipper and dispose of the shipment at the Shipper's expense in accordance with the Shipper's instructions. If the Shipper's instructions are not received within 30 days after the date of mailing such notice, and if the Consignee has not accepted the shipment, United will dispose of the shipment at public or private sale.
- (B) If the Shipper or Consignee requests special notification when a shipment containing perishables is delayed in the possession of United, threatened with deterioration, or unclaimed, instructions for such notification must be given on the air waybill. Without such instructions, United will dispose, at public or private sale, of the shipment without further notice to the Shipper and Consignee.

G46 ROUTING AND REROUTING

In order to protect all shipments accepted for transportation, United will determine the routing of any shipment not routed by the Shipper. United will change the routing in order to expedite the shipment via any air or surface Carrier. The transportation charges shall be no greater than the lowest transportation charge applicable to the service required from origin to destination via United.

Exception: If the Shipper requests United to reroute a shipment to another Carrier for reasons other than those specified in this rule, the transportation charge will be recomputed for the charge applicable via the routing requested by the Shipper.

G50 AVAILABILITY OF EQUIPMENT AND SPACE

United will transport, consistent with its capacity to carry, all cargo accepted for transportation. Irrespective of rates published for a specified market, all shipments are subject to the availability of equipment and aircraft of the size and type necessary to accommodate a Shipment. Passengers and their baggage, Human Remains, QPK, Mail, EXP, shall at all times have transportation priority over all other freight. United will determine, on a reasonable and nondiscriminatory basis, the priority for carriage between shipments, which shipments shall not be carried on a particular flight and which shipments shall be removed at any time or place.

G52 APPLICATION OF RATES AND CHARGES

- (A) All shipments are subject to United rates and charges published in this tariff and the United Cargo Official Local Cargo Rates Tariff, including revisions and supplements in effect on the date a shipment is tendered to United.
- (B) Rates are published for different minimum weights (weight breaks): usually 1, 100 and 220 pounds. Depending on the gross weight of the shipment, the lower of the following rate weight charges apply:
 - (1) The charge computed at the rate applicable to the weight of the shipment.
 - (2) The charge for the minimum weight computed at the lower rate but applicable to the higher weight break.

EXAMPLE:

Published rate per 100 lbs.:	\$50.00	\$45.00
Minimum shipment weight:	100 lbs.	220 lbs.

<u>If actual shipment weight is:</u>	<u>The Charge will be:</u>	
150 lbs.	\$ 75.00	NA
180 lbs.	90.00	NA
200 lbs.	100.00	\$ 99.00*
220 lbs.	110.00	99.00*
300 lbs.	150.00	135.00*

*This charge applies because it is lower than the charge computed at the rate applicable to the lower minimum weight.

Note: The weight in pounds at which the lower charge applies is under the column "Pivot Wt. In Pounds" next to the published rates in the tariff.

UNITED AIR LINES, INC.

SECTION I
GENERAL RULES AND REGULATIONS

RULE

- (C) Precedence of Rates
- (1) On a shipment consisting of commodities subject to a premium rate (exception rating), the general commodity rate will not apply.
 - (2) On a shipment consisting of commodity(s) subject to a specific commodity rate(s), neither the general commodity rate nor the premium rate (exception rating) shall apply to the weight of such commodity(s).

G54 CHARGEABLE WEIGHT PER SHIPMENT

- (A) Transportation charges will be assessed on the gross weight of the shipment based on the greater of the actual weight, or the cubic dimensional weight determined as follows: Cubic measurements will be based on the greatest dimensions (length, width and height) of the shipment, on the basis of one pound for each 194 cubic inches or fraction thereof.
Exception: Not applicable to containerized shipments if rates and charges are published herein.
- (B) Weight Verification:
For the purpose of weight verification, all shipments tendered to the Carrier are subject to reweighing at the point of origin or at the point of destination of the shipment. In the event of a discrepancy between the chargeable weight determined by reweighing the shipment on Carrier's scale and the weight entered by the Shipper on the air waybill, transportation charges will be recalculated on the basis of the chargeable weight determined by reweighing the shipment by Carrier. If the verified chargeable weight is less than the weight entered on the air waybill, Shipper will receive credit by the Carrier for the amount overpaid. If the verified chargeable weight exceeds the weight entered on the air waybill, Carrier will collect from the Shipper amount underpaid due to weight discrepancy.

G56 CHARGES ON MIXED SHIPMENTS

- Charges on shipments containing two or more differently rated commodities will be assessed as follows:
- (A) When the Shipper indicates the weight for each commodity: On the actual or dimensional weight of each commodity specified on the air waybill at the rate applicable to the chargeable weight of the shipment. The chargeable weight shall not be less than the highest minimum weight for any rate used. Any deficit in such chargeable weight shall be charged at the lower applicable rate.
- (B) When the weight for each commodity is not indicated separately on the air waybill: On the chargeable weight of the entire shipment at the highest rate and minimum charge applicable to any commodity in the shipment.

G58 CHARGES PREPAID OR COLLECT

- Transportation charges must be paid by the Shipper (charges prepaid) or by the Consignee (charges collect).
- (A) The following shipments must be prepaid:
- (1) Personal effects and/or used belongings, not for resale.
Exception: Personal effects shipped from a temporary or transient address (college, school, and hotel) will be accepted charges collect.
 - (2) Human Remains, Live Animals, High Value/AEV, shipments addressed to persons restrained of their liberty, shipments with a lower commercial value than their transportation charges, shipments addressed to United States Government Agencies unless shipped under proper U.S. Government Bill of Lading, unless the Shipper guarantees, in writing, the payment of collect charges.

G60 PAYMENT OF CHARGES

- (A) All rates and charges between points within the U.S are published in United States currency.
- Note 1:* When the shipment originates or terminates in the United States and when rates and charges applicable thereto are paid in the United States, they are payable in the lawful currency of the United States.
- (B) For payment made in cash at the time of acceptance by United in the case of a prepaid shipment or at the time of delivery in the case of a collect shipment. Cash is defined as follows:
- Currency
 - Cashier's check
 - Traveler's check
 - U.S. Postal Money Order
- United will accept the following credit cards for the payment of transportation charges:

UNITED AIR LINES, INC.

**SECTION I
GENERAL RULES AND REGULATIONS**

RULE

- | | |
|-------------------------------------|------------------|
| 1. Universal Air Travel Card (UATP) | 6. En Route Card |
| 2. American Express | 7. JCB Card |
| 3. Carte Blanche | 8. MasterCard |
| 4. Diner's Club | 9. VISA |
| 5. Discover Card | |

G62 CLAIM PROCEDURE

- (A) Before United can process a claim, all transportation charges for the shipment involved must be paid. The amount of the claim may not be deducted from the charges due, except where the Consignee has received no part of a shipment.
- (B) See "U.S. DOMESTIC CONTRACT OF CARRIAGE" on United's air waybill for all other provisions applicable to "CLAIMS PROCEDURE."

G64 INTERLINE SHIPMENTS – JOINT CARRIERS' LIABILITY

The Shipper shall have a right of action against the originating Carrier, and the Consignee shall have a right of action against the delivering Carrier, and further, each may take action against the Carrier which performed the transportation during which the destruction, loss, damage or delay took place. The Carriers shall be jointly and severally liable to the Shipper or Consignee.

UNITED AIR LINES, INC.

SECTION II
ACCESSORIAL SERVICES

RULE

S74 IMPORT/TRANSIT/EXPORT REGULATIONS – TERMINAL SERVICE CHARGES USA

Note: Terminal Services Fees are calculated differently in U.S. hubs and some other larger stations. See "Exceptions" below.

(Except as otherwise indicated, applicable only at points in the United States for international carriage.) Terminal service charges as described below will be assessed to the Shipper or Consignee named in the air waybill, and will apply whenever such services are performed by United.

(A) Import:

(1) Carrier Import Service Charge/Terminal Service Fee

(a) United will charge USD 80.00 per Carrier's air waybill for providing assistance and/or facilities in presenting a consignment to Customs for examination and/or opening or closing packages, if required. In the event Carrier's air waybill includes more than one freight forwarder's air waybill, such charge will be assessed upon each freight forwarder's air waybill.

Note: Entire consolidated consignments consisting of two (2) freight forwarder's air waybills or more which are removed from United's bond for Customs processing at alternate locations (in-bond permit to transfer) will be assessed a single USD 80.00 charge. Consolidated consignments consisting of a single freight forwarder's air waybill (back-to-back) will be assessed a single USD 80.00 charge. On consolidated consignments traveling under a GBL, each freight forwarder's AWB representing the personal effects of U.S. Military personnel will be assessed a USD 25.00 charge.

Exceptions:

- In EWR, IAD, JFK, LAX, ORD, SEA and SFO, the charge described in (a) above is USD **90.00** per MAWB or HAWB

(b) A charge of USD 75.00 per shipment will be assessed for post entry, i.e., where U.S. Customs requires formal inspection and clearance of any unaccompanied baggage shipped as cargo beyond a point where passenger baggage is normally cleared by Customs. Air freight charges will not be applicable from port of entry to the final United destination.

Note: Local exceptions may apply at some stations.

(2) Service Charge for International Inbound Change of Destination

(Applicable only on international inbound shipments)

When requested in writing by the Shipper or Shipper's Agent to terminate a shipment in route at a destination other than listed on the international air waybill, a charge of USD 125.00 will be assessed in addition to all other applicable charges.

(3) Service Charge for Domestic Inbound Change of Destination

(Applicable only on international inbound shipments)

When requested in writing by the Shipper or Shipper's Agent to terminate a U.S. domestic shipment in route at a U.S. destination other than listed on the domestic air waybill, a charge of USD 50.00 will be assessed in addition to all other applicable charges.

(4) Preparation of Carrier's Certificate and Release Order (U.S. Customs Form C-7529)

When requested by the Shipper or Consignee to prepare more than one copy of Carrier's Certificate and Release Order, or any other documents necessary to permit customs clearance of a shipment, a charge of USD 10.00 will be made for each additional copy prepared, except as noted below:

Exception: No charge will be made if such documents are prepared by the broker or Consignee and only Carrier's signature is required.

(5) Preparation of Transit Air Cargo Manifest or an Immediate Transportation Entry Form

When requested by the Consignee/agent to prepare more than one Immediate Transportation Entry Form (U.S. Customs Form 7512) or a Transit Air Cargo Manifest, United will charge USD 10.00 for each such form in excess of one.

(6) Partial Delivery of A Single Consignment Covered by One U.S. Customs Entry

(a.) Delivery of piece(s) selected by the Consignee/agent:

When Carrier is requested by Consignee/agent to provide partial delivery of a consignment which is ready for delivery, a charge of USD 14.00 per partial delivery will be assessed.

(b.) Delivery of non-selected piece(s):

When Carrier is requested by Consignee/agent to provide partial delivery of a consignment which is ready for delivery, a charge of USD 10.00 per partial delivery will be assessed.

Note: For the purpose of this rule, part of a consignment shall consist of one package, piece or bundle, or two or more packages, pieces or bundles cleared through Customs on one Customs Entry.

UNITED AIR LINES, INC.

SECTION II
ACCESSORIAL SERVICES

RULE

S74 IMPORT/TRANSIT/EXPORT REGULATIONS – TERMINAL SERVICE CHARGES USA (continued)

- (7) Delivery of Documents
When requested by the Shipper or Consignee to deliver documents pertaining to a shipment(s) to a person(s) other than the Consignee named on the air waybill or his Customs broker, Carrier will assess a charge of USD 25.00 for such delivery, except as noted below:

Note: The above charge will not apply when delivery is made on the premises of the Carrier or when delivery is made by mail.

- (8) Release of Parts of Multi-piece Shipments Covered by One U.S. Customs Entry
When requested by the Shipper or Consignee to release any part of a multi-piece shipment, United will release such part subject to a charge of USD 25.00 per part of such service.

- (9) Release of Parts of Multi-piece Consignments Covered by More Than One U.S. Customs Entry
When requested by the Shipper/agent or Consignee/agent to release any part of a multi-piece consignment, Carrier will release such part subject to a charge of USD 25.00 per part of such service.

- (10) Storage Charges

Note: Free storage is calculated differently in U.S. hubs and some other larger stations. See "Storage Charges Exceptions" below.

United will hold a shipment without charge for a 48-hour period commencing at 00:00 on the first day after complete shipment arrival. Any legal holiday falling within such 48 hours free period shall be excluded from the computation of the free period. The charges will be assessed for shipments that remain in the warehouse after the free allowance period expires per the "Complete Arrival/Storage Begins" chart below. Storage charges are calculated based on the actual weight of the AWB.

Storage fees are calculated at the rate of .10 per lb. or .22 per kg (actual) per day. A minimum charge of \$40 applies to all storage fees.

Complete Arrival	Storage Begins
Monday	Thursday
Tuesday	Friday
Wednesday	Monday
Thursday	Tuesday
Friday	Wednesday
Saturday	Wednesday
Sunday	Wednesday

Legal holidays are: New Year's Day, Birthday of Dr. Martin Luther King, Washington's Birthday, Memorial Day, Independence Day, Labor Day, Columbus Day, Veterans Day, Thanksgiving Day, Christmas Day.

Note:

Storage Charges Exceptions:

- In **DEN, EWR, HNL, IAD, IAH, JFK, LAX, ORD and SFO**, storage begins at 00:00 on the first day 48 hours after complete arrival for GEN and EXP shipments. Free storage is *not* extended by weekends or holidays falling within the free period for GEN and EXP shipments in these nine locations.
- In **EWR and JFK only**, storage begins at 00:00 on the first day 24 hours after complete arrival for TempControl and perishable shipments. Free storage is *not* extended by weekends or holidays falling within the free period for TempControl and perishable shipments in EWR and JFK.
- Free storage is *not* extended by weekends or holidays falling within the free period for GEN and EXP shipments in **DEN, EWR, HNL, IAD, IAH, JFK, LAX, ORD and SFO**, or for TempControl and perishable shipments in **EWR and JFK**.
- Different storage rates apply to United Cargo TempControl shipments. Please contact your United Cargo Sales Professional for these amounts.

UNITED AIR LINES, INC.

SECTION II
ACCESSORIAL SERVICES

RULE

S74 IMPORT/TRANSIT/EXPORT REGULATIONS – TERMINAL SERVICE CHARGES USA (continued)

- (11) Service Charge for Clearance of a Shipment or Parts Thereof at Points Other Than Carrier's Premises
When United provides an employee to assist in Customs release of a shipment or parts thereof at points other than at Carrier's premises, a charge of USD 50.00 will be assessed.
- (12) Service Charge for Clearance of a Shipment at Other Than Normal Duty Hours of U.S. Customs
United will assess a service charge of USD 35.00 for clearance of a shipment at other than normal U.S. Customs duty hours of Monday through Friday, 0800 to 1700 hours.
- (13) Shipments Consigned to a Bank
When United is instructed to obtain a written bank release from the Bank named as Consignee on the air waybill prior to release of a shipment, a service charge of USD 10.00 will be assessed.
- (13) Service Charge for Copy of Cargo Manifest
Upon request, United will provide a copy of a specified Cargo Manifest. A service charge of USD 35.00 will be assessed for each copy requested.
- (14) Opening and/or Closing of Consignments
When opening and/or closing service of consignments or pieces thereof for Customs examination is not provided by Customs, the Shipper or his/her agent, a charge of USD 3.00 per piece opened and/or closed, subject to a minimum charge of USD 10.00 per consignment exported, will be assessed.

S75 SECURITY SCREENING FEE

- (A) US Domestic Shipments (Excluding QPK)
 - (1) Tendered as bulk or in E/EH/EO containers – USD 0.04 per pound (based on actual weight of the shipment) with a minimum charge of USD 10.00 per air waybill.
- (B) US Origin International Shipments
 - (1) Tendered as bulk – USD 0.12 per kilogram (based on actual weight of the shipment) with a minimum charge of USD 10.00 per air waybill.

S76 DOCUMENTATION CHARGES

- (A) Issuance or Completion of Air Waybill
- (B) If United is requested by the Shipper or its agent to issue or to complete an existing air waybill, including itemization of costs, a service charge of USD 20.00 will be assessed. The charge does not apply to QPK shipments.
- (C) Amending/Changing of Air Waybill
A service charge of USD 50.00 will be assessed for any change of name of the Consignee or other statement on the air waybill made necessary by the Shipper's written instructions received after dispatch of shipment from the airport of departure as shown on the air waybill.
Exception: When the Shipper changes the final destination of a shipment and additional transportation is required, he shall be liable for the transportation charges as originally routed plus any applicable transportation charges required to move the shipment to the amended airport of destination requested. These charges are in addition to the service charge of USD 50.00 for air waybill amendment as noted above.
- (D) Upon request, United will provide the shipper or their agent with a copy of written proof that a shipment has been delivered at a charge of USD 25.00 per MAWB.

S86 SHIPPER'S INSURANCE

United no longer offers the option to purchase shipper's insurance on shipments tendered to United Cargo. United Cargo continues to offer customers the option to purchase excess declared value coverage.

S88 COPY OF AIR WAYBILL REQUEST

Upon request, United will provide the Shipper or Consignee with a copy of the air waybill, at a charge of USD 20.00 (CAD 30.00).

UNITED AIR LINES, INC.

SECTION III
CONTAINER RULES

RULE

R1 GOVERNING TARIFFS

- (A) U.S. Domestic Transportation
United's Rates and Charges are governed by the Contract of Carriage on the air waybill and by Section I – General Transportation Rules and Regulations, in this tariff.
- (B) International Transportation
 - (1) International Transportation:
Rules published in this tariff will not apply when domestic rates and charges in this tariff are combined with international rates and charges for the purpose of constructing international through rates and charges from or to points in the U.S.A. United's U.S. segment of transportation will be subject to the rules and regulations published in the rules tariff governing the international portion of such transportation.
- (C) Dangerous Goods Regulations, issued by International Air Transport Association (IATA).

R2 APPLICATION OF RATES

- (A) Except as noted, rates in this tariff apply from airport of origin to airport of destination.

R6 MINIMUM CHARGE PER SHIPMENT

(Not applicable to QPK – Small Package Shipments)

- (A) United's minimum charge will be shown in connection with United's Local Rates.
- (B) The minimum charge per shipment moving jointly via United and other Carrier(s) will be:
 - (1) Between points within the U.S., the sum of USD 45.00 for United's portion of transportation, plus the applicable charge for each Carrier participating in the routing.

R8 CHARGES FOR SHIPMENTS WITH SPECIAL TIE-DOWN REQUIREMENTS

- (A) The provisions of this rule apply only to a shipment which:
 - (1) Because of its size (greatest length, width and height) requires transportation in the container compartment of B-747, B767-300 or B777 aircraft, and
 - (2) Because of special tie-down equipment required by the Federal Aviation Administration, prevents other freight from being loaded on the same pallet.
- (B) The shipment will be accepted for transportation only on aircraft pallets provided by United and on aircraft types specified below:
Pallet sizes: 88 x 125 (LD7) (B747/B767-300/B-777 aircraft only)
60 x 125 inches (LD11 Pallet) (B-747/B-767-300/B-777 aircraft only)
- (C) United will load and unload pallets at a charge of USD 40.00 per shipment.
- (D) The dimensions of any piece (greatest length, width and height) may not exceed the sizes of the pallet provided.
- (E) Transportation charges will be assessed at the applicable bulk general commodity rate for the higher of:
 - (1) The actual weight of the shipment, or
 - (2) 3600 lbs. for each 88 x 125 (LD7) pallet, or 2500 lbs. for each 60 x 125 inch (LD11) pallet.
- (F) Applicable only for prepaid shipments of magazines, newspapers and/or periodicals entering the U.S. Postal Service at destination airport. The U.S. Postal Service Air Mail facility must be shown as the Consignee.
- (G) All copies of the air waybill and each piece in the shipment must be plainly marked by the Shipper: "Deliver direct to A.M.F."
- (H) Transportation charges include delivery to the U.S. Postal Service Air Mail Facility by United Airlines personnel, provided such facility is located on-airport and is easily accessible.

R20 FURNISHING OF CONTAINERS

United will furnish its own containers (Type LD2, LD3, LD4, LD7, LD8, LD11, P6) free of charge, subject to advance arrangements and availability of such container(s) at the time of request.

- (A) An empty container delivered to the Shipper for loading must be returned by the Shipper to United at the same airport within 48 hours beginning at 12:00 midnight after receipt by the Shipper, and
- (B) A loaded container delivered to the Consignee for unloading must be returned by the Consignee to United at the same airport within 48 hours beginning at 12:00 midnight after receipt by the Consignee.
- (C) If the container is not returned to United within the time limits specified in paragraphs (A) and (B) above, a demurrage charge of \$25.00 per container will be assessed for each 24 hour period or fraction thereof in excess of the 48 hours free time limit.

UNITED AIR LINES, INC.

SECTION III
CONTAINER RULES

RULE

- (D) If the container is not returned to United at the same airport as specified in paragraphs (A) and (B) above, a service charge of \$200.00 will be assessed for each container in addition to all other applicable charges.
Exception: Not applicable when a container delivered to the Shipper at the airport named in column 1 below is returned to United at an airport named opposite in column 2 below:

COLUMN 1	COLUMN 2
Baltimore, MD	Washington DC Reagan or Dulles Intl Airport
Chicago, IL (O'Hare)	Milwaukee, WI
John F Kennedy Intl., NY	Newark, NJ
Milwaukee, WI	Chicago, IL (O'Hare)
Newark, NJ	John F Kennedy Intl., NY
Oakland or Sacramento, CA	San Francisco, CA
Portland, OR	Seattle, WA
San Francisco, CA	Oakland or Sacramento, CA
Seattle, WA	Portland, OR or Vancouver BC
Vancouver, BC	Seattle, WA
Washington Reagan or Dulles Intl Airport	Baltimore, MD

R22 CONTAINER DEFINITIONS

Container: Applies to a container meeting the specification and requirements described in Rule R24.
Tare: Weight of the empty container.
Gross Weight: Total weight of the container and its contents.
Net Weight: Maximum container net weight to which the minimum container charge applies.
Shipper & Consignee: For purposes of R20 & R32, 'Shipper' and 'Consignee' also includes any party receiving a container from United.

SECTION III
CONTAINER RULES

RULE

R24 CONTAINER SPECIFICATIONS

TYPE L-2

(Equivalent to IATA Type 8D)
For the 767 Aircraft
PROVIDED BY UNITED

External displacement: 125 cubic ft.
Internal capacity: 120 cubic ft.
Allowable Tare weight: Actual weight
Maximum Gross weight: 2,700 lbs.
Maximum Floor Bearing weight: 200 lbs. per sq. ft.

Dolly transporters available.

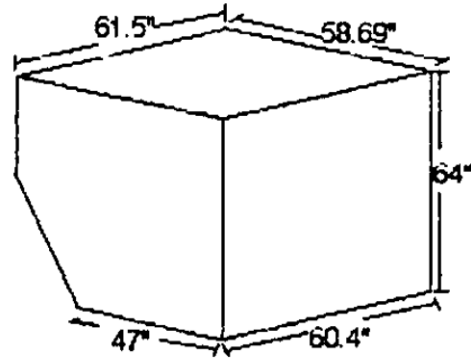

TYPE L-4

(Equivalent to IATA Type 7A)
For the 767 & 777 Aircraft
PROVIDED BY UNITED

External displacement: 201 cubic ft.
Internal capacity: 194 cubic ft.
Allowable Tare weight: Actual weight
Maximum Gross weight: 5,400 lbs.
Maximum Floor Bearing weight: 200 lbs. per sq. ft.

Dolly transporters available.

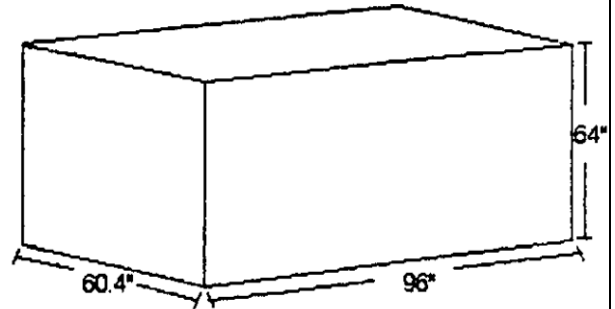

TYPE L-8

(Equivalent to IATA Type 6A)
For the 767 & 777 Aircraft
PROVIDED BY UNITED

External displacement: 280 cubic ft.
Internal capacity: 243 cubic ft.
Allowable Tare weight: Actual weight
Maximum Gross weight: 5,400 lbs.
Maximum Floor Bearing weight: 200 lbs. per sq. ft.

Dolly transporters available.

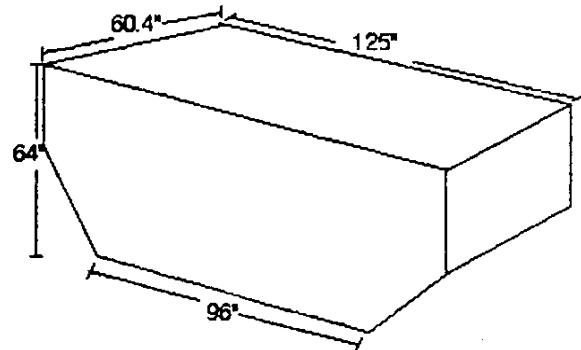

SECTION III
CONTAINER RULES

RULE

R24 CONTAINER SPECIFICATIONS (continued)

TYPE E

PROVIDED BY THE SHIPPER

Maximum external dimensions: L-42", W-29", H-25.5"
 External displacement: 17.9 cu. ft.
 Maximum Gross Weight: 500 lbs. on Widebody Aircraft
 Maximum Gross Weight: 350 lbs. on Narrowbody Aircraft
 Maximum Gross Weight: 250 lbs. for Perishable Commodities
 Maximum Floor Bearing Weight: 200 Lbs. per sq. ft.
 Top Loading Capacity: 600 Lbs.

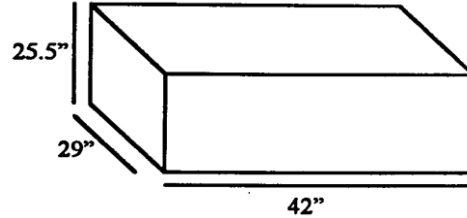

TYPE EH

PROVIDED BY THE SHIPPER

For all aircraft types.

Maximum external dimensions: L-36", W-22", H-22"
 External displacement: 9 cu. ft.
 Maximum Gross Weight: 350 lbs.
 Maximum Gross Weight: 250 lbs. Perishable Commodities
 Maximum Floor Bearing Weight: 200 Lbs. per sq. ft.
 Top Loading Capacity: 600 Lbs.

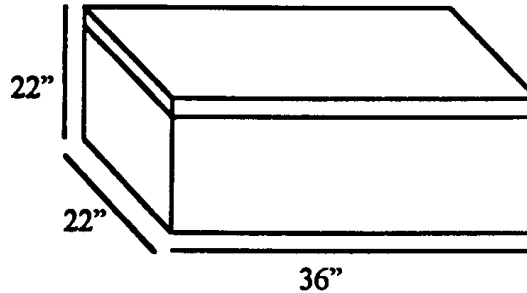

Two boxes securely fastened together,
 within the maximum dimensions of a Type
 EH container will be considered a container.

Note: A securely closed and sealed E or EH container may be attached to a pallet for handling convenience provided the pallet dimensions do not exceed the base of the container or 6 inches in height. E and EH containers with pallets attached may not exceed the maximum gross weight of the container rule and the weight of the pallet will be included in the chargeable weight of the container.

TYPE L-3

(EQUIVALENT TO IATA TYPE 8)
 For the 747, 767 and 777 Aircraft
 PROVIDED BY UNITED

External displacement: 166 cubic ft.
 Internal capacity: 150 cubic ft.
 Allowable Tare weight: Actual weight
 Maximum Gross weight: 3,500 lbs.
 Maximum Floor Bearing weight: 200 lbs. per sq. ft.

Dolly transporters available.

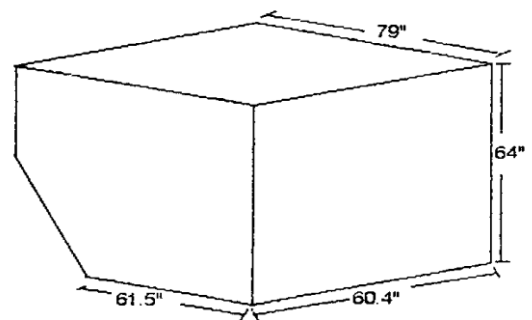

SECTION III
CONTAINER RULES

RULE

R24 CONTAINER SPECIFICATIONS (continued)

TYPE L-N

(Equivalent to IATA Type 8)

For the 747, 767 and 777 Aircraft

PROVIDED BY THE SHIPPER

Maximum external dimensions: L-56", W-55", H-57"

External displacement: 101.6 cubic ft.

Internal cubic capacity: Varies (Container may be any size up to maximum dimensions)

Allowable Tare weight: 100 Lbs.

Maximum Gross weight: 3,160 lbs.

Maximum Floor Bearing weight: 200 lbs. per sq. ft.

Provisions for standard forklift handling are required.

Container type, actual dimensions, and actual empty weight must be marked legibly on two sides of the container.

A pallet with load properly restrained and contoured within the maximum dimensions of a Type L-N container will be considered a container.

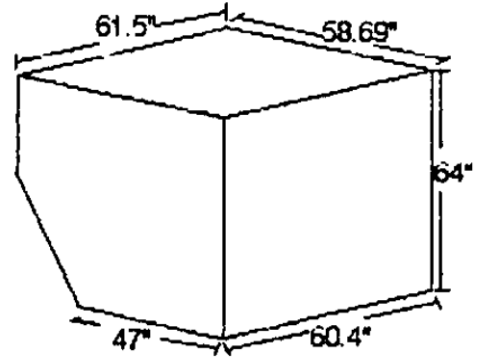

TYPE L-7

(EQUIVALENT TO IATA TYPE 5)

For 747, 767-300 and 777 Aircraft

PROVIDED BY UNITED (PALLET AND NET)

External displacement: 379.9 cubic ft.

Allowable Tare weight: Actual weight

Maximum Gross weight: 10,200 lbs.

Maximum Floor Bearing weight: 200 lbs. per sq. ft.

Dolly transporters available.

A pallet with load properly restrained and contoured within the maximum dimensions of a Type L-7 container will be considered a container.

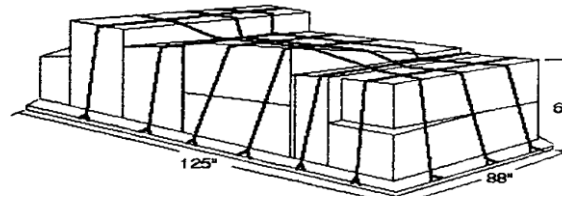

TYPE L-11

(EQUIVALENT TO IATA TYPE 6)

For 747, 767-300 and 777 Aircraft

PROVIDED BY UNITED

External displacement: 277 cubic ft.

Internal capacity: 242 cubic ft.

Allowable Tare weight: Actual weight

Maximum Gross weight: 7,000 lbs.

Maximum Floor Bearing weight: 200 lbs. per sq. ft.

Dolly transporters available.

A pallet with load properly restrained and contoured within the maximum dimensions of a Type L-11 container will be considered a container.

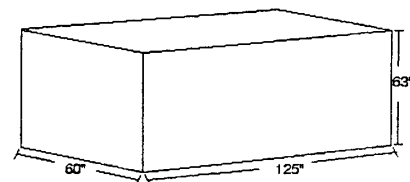

UNITED AIR LINES, INC.

SECTION III
CONTAINER RULES

RULE

R24 CONTAINER SPECIFICATIONS (continued)

TYPE P6

(EQUIVALENT TO IATA TYPE 2BG)

For 747, 767-300 and 777 Aircraft

PROVIDED BY UNITED (PALLET AND NET)

External displacement: 438 cubic ft./12.38 cu. m

Allowable Tare weight: 270 lb. (123 kg)

Maximum Gross weight: 11,100 lbs./5035 kg

Maximum Floor Bearing weight: 200 lbs. per sq. ft.

Dolly transporters available.

A pallet with load properly restrained and contoured within the maximum dimensions of a Type 2BG container will be considered a container

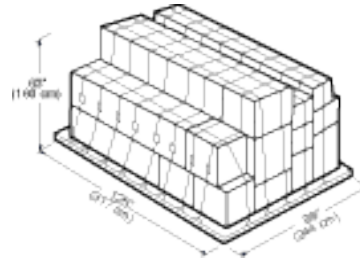

R26 APPLICATION OF CONTAINER CHARGES

(A) All shipments tendered in containers of the type specified in Rule R24 will be rated at the published container charges if published ULD rates exist. The type of container(s) must be specified on the air waybill.

(B) Each container will be assessed the applicable "Charge Per Container" when such rate is published, regardless of the container weight, subject to the maximum gross weight per container specified in Rule R24.

Exception:

(1) Container charges provided with a "Pivot Weight":

The published "Charge per Container" covers the specified pivot weight only. For all weight exceeding the specified pivot weight, apply the "Rate per 100 lbs. "Over Pivot".

(2) When a Shipment consists of more than one container subject to pivot weight, carrier will rate each container separately.

(3) ULD container pricing is not applicable for non-security screened (non-CCSF) freight tendered at US locations. This includes base rates, fuel surcharges and freight processing fees. Pricing for bulk freight shipments, including applicable base rates, fuel surcharges and freight processing fees, will apply to non-security screened (non-CCSF) shipments.

(C) Mixed Commodity Rating

When the contents of any containerized Shipment consists partially of general commodity rated and partially of specific commodity rated articles, the specific commodity rates will not apply.

R28 COMMODITY RESTRICTIONS

The following commodities will not be accepted for transportation in containers or on pallets named in Rule 24.

(A) Live animals, except live fish

(B) Human Remains

(C) Dangerous goods, named in Dangerous Goods Regulations, issued by International Air Transport Association

(D) Edible Fish and Seafood, live or dead, in Type E and EH containers is limited to a maximum weight of 150 lbs.

UNITED AIR LINES, INC.

**SECTION III
CONTAINER RULES**

RULE

R32 LIABILITY FOR CONTAINERS

(A) The Shipper or Consignee is liable for any loss, damage, and repair or replacement costs of any container, structural parts, pallet supporter or straps that have been furnished by United. Replacement charges are as follows:

<u>Container Type</u>	<u>Charge</u>
<u>Structural Part/Accessory:</u>	
L2	\$1,200
L3	\$1,440
L4	\$1,750
L8	\$1,650
L11	\$2,160
L11 Center Door	\$ 415
L11 Side Door	\$ 279
L4, L7, L11 Pallet	\$ 900
L4, L7, L11 Pallet Jacket	\$ 500
L4, L7, L11 Net	\$ 150
Pallet and Net (88" x 125")	\$ 900
Pallet Only (88" x 125")	\$ 900
Pallet Net Only (88" x 125")	\$ 500
Strap	\$ 25
Blanket	\$ 25

(B) For any container not returned to United within 60 days from the time of delivery, the Shipper or Consignee will be liable for loss of the container as described in paragraph (A) above. When charges for loss of container are assessed, rental charges do not apply. But, if the container reported lost is later returned to United, rental charges will be assessed. The 60 day period will be counted from the first calendar day following delivery of the container excluding the first Saturday and Sunday or legal holidays.

R34 RETURN TRANSPORTATION OF EMPTY SHIPPER-OWNED CONTAINERS

(A) If advance arrangements are made, empty Shipper-owned containers will be transported subject to the following charges and conditions:

<u>Container Type</u>	<u>Charge Per Container</u>
LN, L3	\$20.00
E, EH	\$10.00

- (B) (1) Transportation will be performed after accommodation of all other revenue traffic.
 (2) Each E and EH container must be folded flat, tendered as one piece and may not exceed 12 inches in total height.
Exception: Two or more empty Type E or EH containers tied together and meeting these requirements, will be assessed the applicable charge for one container.
 (3) Shipper-owned L3 containers must be certified by the Federal Aviation Administration and a copy of the certification must be supplied to the Carrier, on demand. In tendering the container, the Shipper affirms that the container has been maintained in conformity with Federal Aviation Administration regulations.
 (4) United is authorized to use an empty Shipper-owned container.

R36 CONTAINERS WITH OUTSIDE PIECES

When a shipment consists of containers (as described in Rule R24) and of loose pieces, charges for the loose pieces will be assessed separately at the rate applicable to the chargeable weight of such piece(s). Note: the loose piece(s) will be subject to the applicable minimum charge.

UNITED AIR LINES, INC.

SECTION III
CONTAINER RULES

RULE

R38 CONTAINER LOADING AND UNLOADING

(A) The Shipper must load, or Consignee must unload, containers at places other than United's premises.

Exception: Upon request, unloading service is available at all United wide-body terminals.

(B) Unloading service will not be performed for Articles of Extraordinary Value, or for Shipments moving under Customs Bond.

(C) Charges:

Containers	<u>Unloading Only</u>
Type L2	\$75
Type L3	\$75
Type L4/8	\$100
Type L7	\$200
Type L11	\$100

(D) When unloading services are performed for the container, charges will be the responsibility of the Shipper for prepaid transportation or charges will be the responsibility of the Consignee for collect transportation.

UNITED AIR LINES, INC.

SECTION IV
GEN RULES

RULE

R50 DESCRIPTION OF GEN SERVICE

GEN service is the general service for transportation on United Airlines flights confirmed to the Shipper.

R52 CONDITIONS OF ACCEPTANCE

- (A) The Shipper must request a reservation (Toll free **1-800-UA-CARGO** or **1-800-822-2746**). United will confirm such reservation only if space is available.
- (B) Shipments tendered for US domestic flights must be tendered to United at the air freight terminal at least 2 hours before the scheduled departure of the specified flight.

Exceptions:

- (1) Shipments containing dangerous goods must be tendered to United at least 3 hours before the scheduled flight departure.
- (2) Non-security screened (non-CCSF) shipments (see Rule G27).
- (C) (1) If the actual or the dimensional weight of the Shipment exceeds the weight for which space has been requested and confirmed, United will transport such excess weight on the next flight(s) on which space is available. The GEN rate will apply to the total weight of the Shipment.
- (2) If the excess weight cannot be separated from the portion of the Shipment for which space was confirmed, United will at the Shipper's request, carry the shipment on the next available flight as GEN.
- (3) If the excess weight cannot be separated from the portion of the shipment for which space was confirmed, and there is no space available to the destination within fourteen days, United will refuse the shipment.
- (D) Refunds for service failures are not applicable to GEN service.

R58 RESTRICTION OF SERVICE

GEN Service is not available to the following Premium rated commodities as defined in Section III.C.

- (A) Live Animals (warm-blooded)
- (B) Articles of Extraordinary Value
- (C) Uncremated Human Remains

UNITED AIR LINES, INC.

SECTION V
QUICKPAK RULES

RULE

R60 DESCRIPTION OF QPK (SMALL PACKAGE) SERVICE

- (A) United's QPK Service is available on all United Airlines flights within the U.S. Domestic network, including United Airlines and United Express.
- (B) Shipments containing pieces up to 99.9 lbs. with a maximum size of 90 linear inches or 228 cm (L+W+H) per package are accepted as QPK.
- (C) QPK shipments are guaranteed transportation on the flight(s) selected by the Shipper and confirmed by United at the time of acceptance. (See **Note** in Rule R80 below.)
- (D) QPK shipments totaling over 25 pieces and/or over 500 lbs. require a reservation to be eligible for a refund. Advanced arrangements can be made by calling United Cargo's Call Center at 1-800-PACKAGE.
- (E) QPK shipments routed on United Express flights are limited to a maximum of 5 pieces and/or 150 pounds due to the size of the aircraft.

R62 APPLICATION OF QPK CHARGES

QPK charges are stated in the United Cargo Official Local Cargo Rates Tariff as published on www.unitedcargo.com. Charges are airport-to-airport only.

R64 AIRPORT-TO-AIRPORT SERVICE

- (A) QPK Shipments must be tendered to United:
 - (1) At the QPK Center in the Passenger Terminal at least 45 minutes prior to the scheduled departure of the selected United flight,
Exception: Shipments containing more than 10 pieces must be tendered at least 60 minutes prior to the scheduled departure.
 - or
 - (2) At the Customer Service Counter in United's Air Freight Terminal at least 60 minutes prior to the scheduled departure of the selected flight.
Exception: Check with local facility or unitedcargo.com as some exceptions apply for acceptance and recovery.
- (B) United will confirm transportation on the selected flight(s) by entering the flight number(s) on the QPK air waybill.
- (C) At the destination airport, the Shipment will be available for pick-up by the Consignee at United's QPK Center in the Passenger Terminal or United's Air Freight Facility within 60 minutes after flight arrival.
Exception: QPK shipments containing dangerous goods (as defined in IATA Dangerous Goods Regulations) will be accepted from the Shipper and delivered to the Consignee at United's Air Freight facilities only.
- (D) QPK shipments tendered in shipper-loaded ULDs will be accepted from the shipper and delivered to the consignee at United's air freight facilities only. Drop and recovery standards for containerized QPKs are the same as the specific station standards for EXP service.

R68 SERVICES NOT AVAILABLE

The following services are not available in connection with United's QPK Service:

- (A) Charges Collect Service
- (B) Attendants Accompanying Shipments
- (C) Charges Advanced to Other Agencies

R70 CONDITIONS OF ACCEPTANCE

- (A) Each QPK package constitutes a separate shipment accompanied by an QPK air waybill, but two small packages securely fastened together into one piece will be considered as one QPK if they do not exceed the size and weight limits of an QPK shipment. Opaque courier bags that do not exceed the QPK size and weight limits and are shown as one piece on the air waybill will also be considered as one QPK.
Exception: Two or more QPK packages will be accepted under one QPK air waybill from one Shipper, at one time, at one airport, for transportation on one flight to be delivered to one Consignee, at one time, at one address. All applicable rules, regulations, rates and charges continue to apply as though each QPK package were tendered to United on a separate QPK air waybill. This rule applies to QPK shipments transported on mainline UA and UAX only and is not applicable to interline shipments.
- (B) Each package must be labeled with the name, address and phone number of both the Shipper and the Consignee.
- (C) QPK Shipment charges must be prepaid by the Shipper.

UNITED AIR LINES, INC.

SECTION V
QUICKPAK RULES

RULE

R72 SHIPMENTS NOT ACCEPTABLE

In addition to the excluded commodities and articles named in Rule G16 herein, the following shipments will not be accepted for transportation under United's QPK Service:

- (A) Pieces weighing over 99.9 pounds on United Airlines flights and on United Express flights.
- (B) Pieces with a combined length, width and height exceeding 90 inches.
- (C) Any article listed as "not acceptable" for transportation by air under the terms of Dangerous Goods Regulations, issued by International Air Transportation Association.
- (D) Shipments containing dangerous goods as defined by the IATA Dangerous Goods Regulations are accepted only on United Airlines mainline flights. These shipments are not accepted to any points served by United Express or with an interline carrier.
- (E) Live Animals – excludes seafood for human consumption.
- (F) Uncremated Human Remains Shipments.
- (G) Articles of Extraordinary Value (see Rule G20).
- (H) Shipments with a declared value in excess of \$1200.00.
- (I) United will not accept a shipment for transportation when it reasonably appears the shipment is:
 - a. Improperly packaged, or
 - b. Of an inherent nature of defect which indicates that transportation could not be furnished without loss of damage to the shipment.
- (J) United will not accept QPK shipments over 70 pounds packaged loosely in plastic bags.

R74 DECLARED VALUE

Each QPK piece shall have a declared value of \$50.00 unless the Shipper declares a higher value (not to exceed \$1,200.00 per AWB) on the air waybill. The Shipper must pay an excess rate of 50 cents per \$100.00 or fraction thereof for the declared value exceeding \$50.00.

R75 INSURANCE

United no longer offers the option to purchase shipper's insurance on shipments tendered to United Cargo. United Cargo continues to offer customers the option to purchase excess declared value coverage.

R76 LIMITATION OF LIABILITY

The total liability of United shall in no event exceed:

- (A) The value of the Shipment as determined under Rule R74.
- (B) The amount of any damage actually sustained, excluding any consequential damages.

R78 DISPOSITION OF UNCLAIMED SHIPMENTS

United will hold QPK shipments at destination without charge for 24 hours, beginning at 6:00 p.m. (local time) after flight arrival. Following the first 24-hour period, United will:

- (A) Continue to hold the Shipment at a storage charge of \$2.00 per 24 hours or fraction thereof.
- (B) Notify the Shipper by mail at the address shown on the air waybill, and dispose of the Shipment as directed by the Shipper at the Shipper's expense.
- (C) If no instructions are received within thirty days after the date of mailing such notice and the Consignee has failed to pick-up the Shipment, United will dispose of it at a public or private sale. The Shipper and Consignee remain liable for any deficiency in the amount due United resulting from such a sale.

R80 REFUND FOR SERVICE FAILURE

QPK shipments are guaranteed transportation on the flight(s) specified on the QPK air waybill. Upon request by the Shipper and substantiation that United failed to perform in accordance with this guarantee, United will refund 80% of the freight transport charge.

Note: United reserves the right to terminate or suspend the Performance Guarantee refunds program at any time and for any reason without notice. Refunds will also not be paid if United determines, in its sole discretion, that the delay was caused by weather conditions, mechanical delay of aircraft, or for any other reason beyond United Cargo's control.

UNITED AIR LINES, INC.

SECTION V
QUICKPAK RULES

RULE

R80 REFUND FOR SERVICE FAILURE (continued)

Shipments must be tendered to United within the minimum acceptance time noted below to qualify for the service guarantee:

1. At the QPK Delivery Center in the Passenger Terminal at least 45 minutes (or as posted* for the origin station) prior to the scheduled departure of the selected United flight.
Exception: Shipments containing more than 10 pieces must be tendered at least 60 minutes prior to the scheduled departure.
Or
2. At the Customer Service Counter in United's Air Freight Terminal at least 60 minutes (or as posted* for the origin station), prior to the scheduled departure of the selected United flight.

*Station specific QPK drop/recovery times can be found at www.unitedcargo.com.

No refund will be made if the failure to perform as described is caused by one or more of the following;

- (A) Mechanical
- (B) Weather conditions
- (C) Force majeure (acts of God)
- (D) Civil unrest
 - War
 - Strikes
 - Riots
 - Civil commotion (including acts of terrorism)
- (E) Shortage of labor, fuel facilities or labor difficulties
- (F) Public authorities acting with actual or apparent authority
- (G) Actions, defaults or omissions of the Shipper/Consignee or their agents(s)
- (H) Any other reason that is beyond the control of United Airlines or its agent(s).

The following are exceptions to the QPK refund provisions:

- (A) Shipments in excess of 25 pieces and/or 500 pounds without advance reservations prior to acceptance by United are not eligible for a refund.
- (B) The guarantee does not apply in a case of claims due to loss of or damage to cargo, nor consequential losses due to the delay, the loss of or damage to cargo. Those claims must be handled under the legal liability of the applicable law.
- (C) QPK guarantee is applicable for the following Dangerous Goods. No other Dangerous Goods will be refunded:
 - a) Dry Ice,
 - b) Magnetized materials
 - c) Radioactive - Class 7, (with no transport index (T.I.) White label only, with Research Diagnostic Treatment)
- (D) The guarantee applies to shipments flown on United Airlines and United Express flights only and does not apply to shipments interlined with any other carrier or flown on a routing jointly operated under Partner Carrier agreement.

A refund can be initiated by completing a claim form through www.unitedcargo.com. The claim must be received within seven (7) days after the promised time of availability. Claims submitted via any other method will not be eligible for a refund.

UNITED AIR LINES, INC.

SECTION VI
RATES FOR COMMODITIES REQUIRING SPECIAL HANDLING
(Exception Rating to General Commodity Rates)

RULE

[Back to Index](#)

R90 EXCEPTION RATING

- (A) The following articles and commodities will be accepted for reserved transportation (Toll free **1-800-UA-CARGO** or **1-800-822-2746**).
- (B) Subject to advance arrangements (confirmed flight and space reservations), shipments containing commodities described in paragraph (C) below will have boarding priority following:
 - (1) Passengers and Baggage
 - (2) Human Remains
 - (3) QPK
 - (4) Mail

Note: For transportation via two or more Carriers, reserved transportation will apply only to United's segment(s) of transportation.
- (C) GEN rates and service are not applicable to the following premium commodities :
Animals live: warm-blooded
Articles of Extraordinary Value as defined in Rule G20 herein
Human Remains (uncremated)

R91 HUMAN REMAINS

- (A) The following commodities will be accepted for reserved transportation as EXP service (Toll free **1-800-468-1800** Special Services):
 - Human Remains, uncremated SCR 9091
- (B) SCR 9091 rates apply airport-to-airport only and remove application of all other rates. Subject to advance arrangements (confirmed flight and space reservations), shipments containing commodities described in paragraph (A) above will have boarding priority following: Passengers and Baggage
- (C) Transportation charges: As defined in the United Cargo Official Local Cargo Rates Tariff as published on www.unitedcargo.com.

R92 LIVE ANIMALS

- The following commodities will be accepted for reserved transportation (Toll free **1-800-UA-CARGO** or **1-800-822-2746**) at the applicable zone rate:
- (1) Live Animals, warm blooded SCR1001 must be shipped as PetSafe service
 - (2) Live Animals, cold blooded SCR1002 can be shipped as EXP or GEN service
 - (3) Live Animal rates apply airport-to-airport only and remove application of all other rates
 - (4) Transportation charges: As defined in the United Cargo Official Local Cargo Rates Tariff as published on www.unitedcargo.com.

UNITED AIR LINES, INC.

SECTION VII
EXP SERVICE RULES

RULE

R94 DESCRIPTION OF UNITED AIRLINES EXP SERVICE

United Airlines offers an express service called EXP for transportation on United Airlines flights confirmed to the Shipper.

R96 EXP CONDITIONS OF ACCEPTANCE

(A) **Terms of Transportation**

(1) EXP service is only offered if United Airlines performs/provides the actual transportation from origin to destination.

Exception: Human Remains shipments. Advanced arrangements required.

(2) EXP service must be booked and the air waybill must indicate the service by marking the EXP (Express) box or by entering EXP in the "Handling Information" section of the air waybill.

(3) Shipments cannot be upgraded to EXP service once they are tendered.

(4) When choosing EXP service, the Shipper agrees to accept every routing from origin to destination that United Airlines may select in order to perform the service. Any intermediate stopping place is deemed to be agreed upon.

(B) **Advance Arrangements**

All shipments under this service require advance arrangements. A confirmed reservation is required prior to tender. Cargo must be tendered ready for carriage at the United origin station no less than two (2) hours prior to the scheduled departure of the flight on which space has been designated. United Airlines confirmation of space on all designated flights shall apply only to the shipper's description as to the dimensions and weight of the shipment.

(1) Confirmation by United Airlines shall apply only to the actual or dimensional weight of a bulk shipment, whichever is greater, or to the number and/or type of container(s) in the shipment. If the cubic displacement of a bulk shipment exceeds 166 inches per pound, the Shipper shall inform United Airlines of the actual dimensions of the shipment at the time the reservation is requested. If the actual weight and/ or volume of the shipment as tendered exceeds the weight of the original booking, and/ or the number or type of container(s) exceeds the booking, and in absence of further instructions from the shipper:

- a. If the necessary additional space **is available** for reservation on the same flight(s) on which space has been reserved, the booking will be updated and the entire shipment will be transported as EXP Service.
- b. If the necessary additional space **is not available** for reservation on the same flight(s) on which space has been reserved, the over-tendered amount must be split off and booked on the next available flight.
- c. The excess actual weight and/ or volume will be transported on the next flight(s) on which space is available.
- d. The EXP rate will apply to the total weight of the shipment.
- e. If the excess weight cannot be separated from the portion of the shipment for which space was not confirmed, and if there is no space available during system booking window, the shipment will be refused.

(C) **Method of Payment**

(1) EXP shipments will be accepted on a prepaid or collect basis.

R98 EXP PERFORMANCE GUARANTEE

Note: United reserves the right to terminate or suspend the Performance Guarantee refunds program at any time and for any reason without notice. Refunds will also not be paid if United determines, in its sole discretion, that the delay was caused by weather conditions, mechanical delay of aircraft, or for any other reason beyond United Cargo's control.

(A) EXP shipments are guaranteed transportation on the flight(s) reserved by the Shipper and confirmed by United at time of acceptance. Upon request by the shipper/consignee and substantiation that United failed to perform in accordance with this guarantee, United will refund 80% of the freight transport charge. The refund is limited to a maximum of USD \$5,000 of the freight charges or a respective amount in local currency as per the United Airlines Cargo air waybill, whichever is less. However, in no case shall the refund exceed the total gross freight transport charges paid.

(B) Shipments must be tendered to United Airlines within the minimum acceptance time noted on the air waybill to qualify for the service guarantee.

(C) Shipments tendered to United Airlines in excess (volume and/or weight) of the advance reservation in which the over tendered portion must be accommodated on a separate flight will not qualify for the service guarantee.

(D) No refund will be made if the failure to perform as described is caused by one or more of the following:

- 1) Aircraft Mechanical delay or cancellation
- 2) Weather conditions
- 3) Force majeure (acts of God)
- 4) Civil unrest
 - War
 - Strikes
 - Riots
 - Civil commotion (including acts of terrorism)
- 5) Shortage of labor, fuel facilities or labor difficulties
- 6) Public authorities acting with actual or apparent authority

UNITED AIR LINES, INC.

SECTION VII
EXP SERVICE RULES

RULE

R98 EXP PERFORMANCE GUARANTEE (continued)

- 7) Actions, defaults or omissions of the shipper/consignee or their agents(s)
 - 8) Any other reason that is beyond the control of United Airlines or its agent(s).
 - 9) Cargo is interlined with another air carrier.
 - 10) Loading the cargo on the aircraft would compromise the safety of the shipment, other cargo, or the aircraft itself.
- (E) The guarantee does not apply in a case of claims due to loss of or damage to cargo, nor do consequential losses due to the delay, the loss of or damage to cargo. Those claims must be handled under the legal liability of the applicable law. EXP guarantee is applicable for the following Dangerous Goods: Dry Ice, magnetized materials, Radioactive - Class 7, (with no transport index (T.I.), White label only, with Research Diagnostic Treatment). No other Dangerous Goods will be guaranteed.
- (F) **Filing a claim:** To request a refund a claim must be filed by one of the following methods:
- 1. Fill out the service claim form at www.unitedcargo.com, or
 - 2. Call 800-UA-Cargo (800-822-2746), or
 - 3. Email cargoproductrefund@united.com
- The claim must be received within seven (7) days of recovery. Claims submitted via any other method will not be eligible for a refund.