

MAPP

CONSTRUCTION

Document Number: HSE64-001

Created: February 11, 2013

OFFSHORE CRANE OPERATION AND MAINTENANCE

Author: A Holland

MAPP Construction - Corporate
344 Third Street
Baton Rouge, LA 70801
(225) 757-0111

MAPP Construction – New Orleans
601 Poydras St., Suite 1715
New Orleans, LA 70130
(504) 833-6277

MAPP Construction - Houston
11511 Katy Freeway, Suite 145
Houston, TX 77079
(281) 582-3696

MAPP Construction - Dallas
3131 Turtle Creek Blvd, Suite 1300
Dallas, TX 75219
(214) 267-0700

<u>Rev Date</u>	<u>Rev Seq</u>	<u>Description</u>	<u>Revised By</u>
2/11/13	1	Original - Reformat	A. Holland

Offshore Crane Operation and Maintenance Program

Acknowledgment Page

I hereby commit as an employee of _____ or as a contract employee working for MAPP Construction, LLC that I understand the criticality of complying with this MAPP Offshore Crane Operation and Maintenance Program.

I have read and understand the MAPP Offshore Crane Operation and Maintenance Program and will abide by the procedures contained herein.

Work Location:

Employees Name (Print): _____ Signature: _____

Company Name: _____ Date: _____

Instructors Name (Print): _____ Signature: _____

Company Name: _____ Date: _____

TABLE OF CONTENTS

1.0	OBJECTIVE	1
2.0	PURPOSE AND SCOPE	1
3.0	DEFINITIONS	1
4.0	REFERENCES	2
5.0	RESPONSIBILITIES	2
5.1	Crane Operator	2
5.2	Hoist Operator.....	3
6.0	OPERATING PRACTICES, PROCEDURES, AND REQUIREMENTS	3
6.1	Crane Equipment	3
6.2	Operating Practices.....	4
6.3	Heavy Lifts.....	5
6.4	Personnel Transfer.....	8
6.5	Rigging Practices	9
6.6	Boat, Shorebase and Load Rigging/Marking.....	10
7.0	INSPECTION AND MAINTENANCE	12
7.1	Operational Inspections and Maintenance	12
7.2	Mechanical (Preventative) Inspections and Maintenance	13
7.3	Required Inspections	14
7.4	Deficiencies.....	15
7.5	Records	15
7.6	Load Test and Pull Test	16
8.0	CRANE OPERATOR QUALIFICATIONS	16
8.1	Physical Requirements	16
8.2	Training Requirements	17
8.3	Crane Operator Qualifications / Classifications	17
8.4	Suspension of the Ability to Operate an MAPP Crane	18
9.0	RIGGER QUALIFICATIONS	18
9.1	Physical Requirements	18
9.2	Training Requirements	18
10.0	OVERHEAD/PORTABLE HOIST OPERATING PRACTICES, PROCEDURES AND REQUIREMENTS... 18	
10.1	Hoisting Equipment	18
10.2	Rigging Practices	19
10.3	Hoist Inspection and Maintenance	19
10.4	Air Tuggers/Hoist/Winch.....	19
11.0	CONTRACT/RENTAL CRANES	20
11.1	Jack-Up Boats.....	20
11.2	Rental Cranes.....	20
	APPENDIX A - FIELD SUMMARY	21
	APPENDIX B - CRANE TERMINOLOGY	22
	APPENDIX C - RIGGING SPECIFICATIONS AND INFORMATION	23
	APPENDIX D - STANDARD HAND SIGNALS	31
	APPENDIX E - HEAVY LIFT WORKSHEET	32
	APPENDIX F – INSPECTION FORMS	33
	Crane Pre-Use/Preventative Maintenance Inspection	
	Monthly Inspection	
	Quarterly Inspection	
	Annual Inspection	
	Self Inspection Checklist	
	APPENDIX G – OFFSHORE DRUM RACK DESIGN GUIDELINES.....	35
	APPENDIX H – BOTTLE / CYLINDER RACK DESIGN GUIDELINES	36
	APPENDIX I – HIGH ANGLE BOOM KICK OUT VISUAL GUIDANCE	37
	APPENDIX J – NSL “Slinging Tubulars” section (2012 version)	38
	APPENDIX K – Operator Medical Evaluation Form	

OFFSHORE CRANE OPERATION and MAINTENANCE GUIDELINES

NOTE: MAPP Construction employees do not normally perform work offshore or as offshore crane operators, and any subcontractor performing this type of work shall be required to submit for approval an Offshore Crane Operations Program meeting or exceeding regulatory guidelines. If a client has an Offshore Crane Operations Program MAPP and all subcontractors shall follow that policy. In the absence of any subcontractor or client policies, all workers shall comply with the following policy.

1.0 OBJECTIVE

To set guidelines for the safe operation, maintenance and inspection of all offshore cranes and associated equipment (including criteria for overhead/portable hoists and load rigging practices) in order to assure safe operation and mechanical integrity.

2.0 PURPOSE AND SCOPE

2.1 This program is to ensure that all cranes, hoists, slings and wire rope used on MAPP client offshore operated facilities are properly inspected, maintained and operated according to the manufacturer's recommendations, client policies, applicable OSHA regulations, and applicable U.S. Coast Guard regulations.

2.2 These guidelines pertain to all MAPP, subcontractor, and third party/contract cranes used in conjunction with offshore operations whether operated by MAPP personnel, subcontract personnel, or other (contract) personnel. These guidelines do not apply to cranes on movable offshore drilling units, derrick barges, or lay barges, with the exception of Section 6.0 for Boat and Shorebase Operations. This equipment shall be covered under applicable regulations governing their operation and applicable manufacturer's recommendations. Each contractor will be solely responsible for compliance with these requirements.

2.3 Overhead/portable crane or hoist guidelines/procedures are addressed in Section 10.0.

3.0 DEFINITIONS

Crane Operator: An individual qualified through training and experience meeting requirements of API RP 2D (latest edition) and Section 8.0 of this Crane Operation and Maintenance Program.

"Field Fabricated": The practice of facility personnel using materials available onsite to fashion a makeshift device (i.e. slings) in lieu of utilizing such a device specifically manufactured and tested by an appropriate recognized agency.

Load: An object that must be lifted or moved whose total weight equals that of the object and all tackle, wire rope and hardware used to lift or move it.

Load Radius: The distance from the centerline of the crane turntable to the centerline of the load (true vertical of the load bearing hook).

Load Test: is defined as a load that is applied to the crane structure at 125% of the crane's static rated capacity as identified on the crane's load chart. A load test is required under the following conditions:

1. New cranes being placed into service.
2. Cranes that are being permanently relocated.
3. Temporary cranes after each rig-up or relocation.

NOTE: A Pre and Post Annual Inspection is required during Load Test process.

Overhead Hoist: A semi-portable trolley-type hoist attached to a fixed beam usually used for lifting small loads within a specific area or building.

Portable Hoist (Tugger): A portable hoist usually attached to the platform structure used to perform lifting and/or moving of equipment in areas that preclude platform crane or overhead hoist usage.

Personnel Basket: A synthetic rope-type basket specifically manufactured for safely transferring personnel to/from boats and offshore platforms.

Pull Test: is defined as a load that is applied to the crane structure that will not exceed 100% of the crane's static rated capacity as identified on the crane's load chart.

Required Safety Devices: Those safety devices required by regulations, recommended practices and/or industry operating policies that are designed to prevent or minimize accidental occurrences (e.g. anti-two blocking devices, high boom angle kick-outs, etc.).

"Rigger": An individual, qualified by training meeting the requirements of API RP 2D (latest edition), assigned the duties of properly attaching slings, hooks, etc., to a load prior to a lifting or hoisting operation. See Section 9.0 for requirements.

4.0 REFERENCES

4.1 These guidelines have been based in part on guidelines and recommendations contained in the latest editions of:

- API Spec 2C - Specification for Offshore Cranes
- API Spec 9A - Specification for Wire Rope
- API RP 2D - Recommended Practice for Operation and Maintenance of Offshore Cranes
- API RP 9B - Recommended Practice on Application, Care, and Use of Wire Rope for Oil-Field Service

4.2 All crane operations on MAPP operated facilities shall be conducted in accordance with the latest editions of the above mentioned publications.

5.0 RESPONSIBILITIES

5.1 Crane Operator

5.1.1 All crane operators shall read and understand these guidelines.

5.1.2 The crane operator is responsible for all crane operations including rigging practices, mechanical integrity of the crane as described in Section 7.0, the equipment used, i.e. slings, shackles etc., and the decision to proceed with lifting operations.

5.1.3 The crane operator is responsible for performing the Pre-Use and Monthly inspections and/or subsequent inspections (as specified in Section 7.1), and assuring that all rigging equipment is sound and tagged (certified) (API-RP-2D) as required.

5.1.4 The crane operator shall designate or identify the riggers and signal personnel in order to enhance communications and reduce confusion.

5.1.5 The crane operator shall conduct a pre-lift discussion and JSA with all personnel involved with the upcoming lifting operation and assure that all riggers are qualified.

5.1.6 While operating the crane, the crane operator shall:

- Take into consideration weather and sea conditions and check the appropriate static and dynamic lift charts to determine if the load can be lifted safely.
- Not operate the crane if unable to do so safely (e.g., due to illness, taking medication,

etc.).

- Not exceed the limitations imposed by safety devices (e.g., boom kickouts) or structural constraints (e.g., safe boom angles for a given weight). Refer to section 6.2 (O) for further instruction.
- Have the authority to stop the operation if unsafe conditions develop.

5.2 Overhead/Portable Hoist Operator

5.2.1 All hoist operators must read and understand these guidelines prior to operating an overhead/portable hoist.

5.2.2 The hoist operator is responsible for all hoist operations including rigging practices, the mechanical integrity of the hoist, the equipment used, and the decision to proceed with lifting/tugging operations.

6.0 OPERATING PRACTICES, PROCEDURES, AND REQUIREMENTS

Crane operation is a privilege by qualification, not a right of employment. Rejection and/or cancellation of a "Qualified Operator" status is at the discretion of MAPP.

6.1 Crane Equipment

Except for maintenance personnel performing maintenance duties, no personnel shall operate a crane on an MAPP operated facility unless they have a valid and current crane operator qualification card issued through an approved third party trainer in accordance with the provisions of API RP 2D and in accordance with the requirements outlined in Section 8.0. All Crane Operators will also be required to read, understand and follow this MAPP Offshore Crane Operation and Maintenance Program. All operations, including maintenance operations, shall be conducted in a safe manner. At a minimum this shall include the following:

- a)** The crane operator shall perform a pre-use inspection as detailed in Section 7.1 prior to the first crane use of the day, prior to or during each change in operator and then as the qualified operator deems necessary during the day for extended operations or changes requiring a revision to the JSA affecting crane operations.
- b)** Lift cables shall not be wrapped around the load (slings, chokers or other rigging equipment must be used).
- c)** There shall always be a minimum of half (1/2) a layer of cable left on the bottom layer of the auxiliary and load winch cable drums and a minimum of three-quarters (3/4) of a layer of cable left on the bottom layer of the boom winch cable drum at its lowest operational point (i.e., crane boom at horizontal with bridle and boom in tension, or headache ball/load block at water level).
- d)** Required crane safety devices (i.e., anti-two blocking mechanisms on hoist lines, high and low boom angle shutdowns) shall be functioning properly whenever the crane is in operation. The exception to this requirement is whenever the crane is being operated for the purpose of repairing one or more of the safety devices.
- e)** Main hoist lines shall not be twisted around each other.
- f)** A crane file shall be kept on board for the purpose of maintaining records of inspections, maintenance and usage. A minimum of four years shall be available.
- g)** A crane's basic configuration (e.g., boom length, wire rope size and type, etc.) shall not be changed without permission from the Maintenance Foreman or Superintendent. It shall be the Maintenance Foremen's responsibility to ensure that a new load chart is provided to match the new configuration. MAPP's MOC process should be followed for this change.
- h)** All lift cables/wire ropes and slings shall be inspected for condition, adequate lubrication and appropriate certification tags.

- i) Helicopter warning lights are required to be installed on all manned facilities where the crane boom could reach the heliport and interfere with helicopter operations. The warning light should be installed on the crane gantry or other location where the light is clearly visible to all approaching or departing aircraft.

6.2 Operating Practices

Except for maintenance personnel performing maintenance duties, no personnel shall operate a crane on an MAPP operated facility unless they have been trained by an approved third party instructor in accordance with the provisions of API RP 2D and in accordance with the requirements outlined in Section 8.0. All Crane Operators will also be required to read, understand and follow this MAPP Offshore Crane Operation and Maintenance Program. All operations, including maintenance operations, shall be conducted in a safe manner. At a minimum this shall include the following:

- a) The operator will perform Pre-Use and Monthly Inspections regardless of usage time.
- b) The crane operator will become familiar with the load in respect to its weight and configuration including all special rigging used to lift it prior to making the lift.
- c) When determining if the fast line can be used for a lift, identify from the load chart the dynamic lifting capacity of the crane (fast line) at the lowest proposed lift angle or longest radius. If the lift exceeds 75% of the rated capacity of the fast line capacity, the fast line shall not be used.
- d) The crane shall not be overloaded.
- e) Loads shall not be moved over personnel.
- f) All personnel must be clear of the load before it is lifted or moved.
- g) Crane lifting operations may not begin until the crane operator has designated one qualified signal person for all areas where the crane operator's vision is, or will be, obstructed during any part of the lift. The crane operator and the signal person(s) must maintain direct communication with each other throughout their portion of the lift either visually or by radio. Examples of situations requiring two signal persons would include lifts from one deck to another deck (if the signal person from one deck remained on that deck) and lifts to and from boats.
- h) The crane operator shall respond to signals only from the designated signal person(s), but shall obey any "**STOP**" signal from anyone whenever it is given. If a stop signal is given, crane operations shall cease until the appropriate designated signal person verifies that it is safe to resume operations. When it is safe to resume operations, the appropriate designated signal person shall communicate that fact to the crane operator.
- i) Verify that weather and sea conditions will permit safe crane operations. This shall be determined by all parties involved (Boat Captain, Riggers, Crane Operator or other personnel). STOP work authority can be exercised by anyone at any time. The boom shall be properly cradled under such conditions that are deemed to be unsafe.
- j) When a helicopter approaches a facility, the crane boom shall be swung away from the heliport, the swing lock shall be engaged, and the crane operator shall step out of the cab of the crane. Pilots have been instructed not to land if anyone is in a crane cab. If a lift is in progress, the lift should be completed before the crane is secured. The approaching helicopter should obtain a "green deck" from the facility operations personnel prior to landing.
- k) On lifting, the load hook shall be positioned directly over the load to avoid a side thrust on the boom and to prevent the load from swinging. The swing brake should be unlocked at this time to allow the boom to track the load.
- l) The crane shall not be used in a manner that may result in shock loading (for example, pulling up grating that is still welded to the platform).
- m) The crane operator shall inspect all boom attachments (lights, boom load block protectors, boom walkway rub guards, etc.), during each pre-use inspection to ensure that nothing is loose and/or poses a potential fall hazard.

- n) Each crane operator will inspect the entire boom for cracks, bends or other deformities during the pre-use inspection.
- o) High angle boom kick out authorization procedure:
 - i. Each platform with a crane shall paint, in **RED**, a perimeter line near the pedestal indicating the area in which the high angle boom kick-out would be activated or other safety devices for the boom.
 - ii. **NO** part of the load shall enter within this perimeter at any time unless all of the following are completed:
 - 1. Obtain written approval from MAPP Superintendent or Subcontractor Foreman;
 - 2. JSA must be performed
 - 3. Establish a designated spotter to ensure that the crane operator stays clear of the boom stops.
 - 4. Place the system in override position if necessary to safely position/move the load.

6.3 Heavy Lifts

MAPP's intention is to have every lift a "safe" lift, without incident or injury to persons or equipment. The following is the procedure to be followed in achieving this goal.

"Heavy" lifts are those whose weights are within 25 % of the maximum rated *Dynamic and/or Static* capacity (depending on type of lift) of the crane at any given boom angle.

6.3.1 Qualification of Heavy Lifts

Qualification of a "Heavy" Lift:

- 1 Identify the weight of the load to be lifted.
- 2 Using a platform deck drawing, identify the load radius at proposed boat or platform location for the initial lift and/or the proposed boat or platform location to which the load is to be placed.
- 3 From the load chart, identify the dynamic and/or static lifting capacity (depending on type of lift) of the crane at the lowest proposed lift angle or longest radius.
- 4 Subtract 25% from the rated dynamic and/or static lifting capacity (depending on type of lift) of the crane at the lowest proposed angle or longest radius.
- 5 The result is the "determining weight".
- 6 If the weight of the load exceeds the "determining weight", the criterion has been met to call the lift "Heavy".

Note: Refer to Appendix E – "Heavy Lift Worksheet"

6.3.2 Heavy Lift Procedures

The MAPP Superintendent will be notified when there is a potential Heavy Lift situation for any site crane. The Subcontractor Foreman will be responsible for ensuring that inspections and maintenance stated herein to assure proper mechanical integrity and qualified operation of the crane. .

6.3.3 Pre-Lift Information

"Heavy Lift" - Pre-Lift Information To be documented and sent to Supervisor in charge of job.

- 1 The weight of the lift and center of gravity will be verified "onshore" by actual load cell test (not estimated) and documented.
- 2 Boom angle and radius will be verified for the "off load" boat position and the

capacity of the crane at that angle noted.

3 The distance of the boom tip to the water at the proposed lift angle from the boat or vessel will be verified and documented.

4 The size and weight per foot of the lifting wire rope, weight of the block, tackle and slings will be verified.

5 Using items 2, 3 and 4 the weight of the wire rope and block when the block is at water level will be determined and added to the load weight. This total will be the "lift weight".

6 The radius, boom angle and lifting capacity at the final load location will be verified.

7 A drawing of the lift including the facts stated above will be developed.

8 Determine whether or not the platform production process needs to be shut in based on the areas in which the load will be moved.

9 When a lift boat is used, a vessel pre-load procedure will be obtained from the vessel operator and authorized by the Project Engineer.

Using the information above, the Supervisor or Foreman will determine if the lift can be made with the given equipment.

6.3.4 Pre-Lift Activities "Heavy-Lift" - Pre-Lift Activities

1 The site crane that will be used to conduct the heavy lift will have a Heavy Lift inspection and **PULL TEST** performed. This inspection and pull test must be performed prior to making the lift. If the crane is expected to continue conducting heavy lift operations during a particular project, a Heavy Lift inspection and pull test should be performed every 30 days but shall not exceed 45 days without approval from the MAPP Superintendent. These inspections will be coordinated through the Subcontractor Foreman.

2 Any discrepancies found during the inspection will be corrected before the lift is made.

3 All rigging (slings, shackles etc.) will be inspected, certified and tagged accordingly.

4 Special rigging will require a rigging diagram sent to the field.

5 Slings with hooks will not be used for the lift; they must have thimble eyes and shackles.

6 The crane block must have a lockable hook latch.

7 Radio Communication will be provided. They will be used by the crane operator, flagman on the boat and flagman on the platform.

8 A pre-job safety meeting and JSA need to be conducted by all personnel involved with the lift.

9 The Heavy Lift Worksheet locate in Appendix E of this program will be completed, reviewed and understood by all personnel.

Load Out Point (Dock)

1 The load out dock dispatcher or Foreman will be informed in writing of the weight and dimension of the lift.

2 The load will be spotted on the boat by direction of the job coordinator and/or Vessel Captain.

3 The Rigger must assure proper egress availability during rigging operations.

4 If slings or spreader bars are supplied by the vendor and are to go with the load to the location, they will be inspected, verified to match rigging drawing, certified and tagged accordingly.

5 The load will be marked/labeled according to the requirements set forth in section 6.0.

6 The load will have "knot-less" tag lines, 15' long minimum, affixed at right angles or each corner at the lowest point of the lift.

7 The dock foreman will assure that the MAPP Material Transfer contains all weights and dimensions of the equipment being sent to the location.

6.3.5 Making the Lift

Only an API-RP-2D qualified operator meeting the requirements of Section 8.0 of this program will be allowed to operate the crane to make the lift (must have crane card or proof of qualifications readily available).

1. A “Crane Operation – Heavy Lift” safety meeting/lift plan will be held and attended by all on location and Boat Captain/crew prior to the lift and will include the following.
 - JSA Development and Review Stop Work Authority Policy
 - The lift drawing / lift worksheet will be reviewed and understood by all.
 - Each person’s duties throughout the lift.
 - Proper rigging of the load.
 - Determine if platform shut-in is necessary.
 - Pinpoint identification on the deck of the boat and/or platform.
 - Emphasis that no one will get under the load at any time.
 - The path that the lifted object will take once it leaves the boat or platform to its landing position.
 - Instructions to the boat Captain on what he will do once the load leaves or approaches the deck.
 - Flagman positions on the platform to direct the load to its final position.
 - Emphasize that all other personnel will be in constant sight of the Flagman and/or Crane Operator.
 - All other operations in the affected areas on the platform will cease while the lift is being made.

- 1 The Crane Operator will perform and document a “Monthly” and “Pre-Use” inspection on the crane immediately before the lift is made.
- 2 The platform or system will be “shut in” if need be.
- 3 The riggers on the boat or platform will verify that slings, shackles and other attachments are tight, secure and free of obstruction.
- 4 The Crane Operator and Job Coordinator or Boat Captain will have a final discussion on the lift and its safe accomplishment.
- 5 When all involved are satisfied and agree that the lift can be made without incident, the lift will be made.
- 6 As the lift is made, radio communications will be constantly used by the Crane Operator and Flagmen to assure everything is going as planned.
- 7 The lift will be aborted (Refer to Stop Work Authority Policy) if any person identifies a potential hazard.
- 8 After the lift has been made the Job Consultant will contact the Project Engineer and confirm the lift is complete.

All of the above activities concerning the lift, meetings, etc. will be documented on the daily project reports and appropriate forms.

6.4 Personnel Transfer

- 6.4.1 A personnel basket will be used for all offshore transfers between a facility and a boat whenever the crane is used to make the transfer.
- 6.4.2 Hoists shall be equipped with a personnel handling certification tag. The hoist certifications are maintained in the crane file. Personnel certified hoists are maintained according to manufacturer’s recommendations.
- 6.4.3 Only properly designed workbaskets shall be used as work platforms or workstations. Personnel baskets are not designed for this purpose and shall not be used as such.

- 6.4.4 Crane hooks used to lift personnel baskets will have a positive locking device equipped with a locking pin. Spring loaded latches and self-latching mechanisms must also be closed and secured with a locking pin.
- 6.4.5 All shackles incorporated in a Personnel Basket lifting configuration will be tight and wire locked.
- 6.4.6 The crane operator, while transferring personnel between vessels or from a vessel to a platform, should raise the personnel basket only high enough off the deck to clear all obstructions.
- 6.4.7 Personnel lifts to and from a motor vessel shall be swung over water and not directly over the vessel whenever possible.
- 6.4.8 All personnel being transferred over water must wear an approved Personal Floatation Device (PFD) (Type 1 or Type 5) that is properly donned.
- 6.4.9 The number of personnel and/or weight allowed to ride on the personnel basket shall not exceed the manufacturer's rated capacity.
- 6.4.10 Personnel riding on the personnel basket shall ride on the outside of the basket, facing inward, with their arms locked around the netting.
- 6.4.11 Personnel baskets will be equipped with tag lines free of knots and must be a minimum of 15 feet in length.
- 6.4.12 Cargo other than personal hand luggage and small supplies and equipment will not be transferred with the personnel basket. Cargo must not overhang the edge of the personnel basket.
- 6.4.13 All personnel baskets will have a safety "shock" load strap.
- 6.4.14 Cranes shall not be used to raise or lower personnel into or out of tanks or other production vessels. Only properly designed personnel hoisting equipment shall be used for this purpose.
- 6.4.15 Personnel are not allowed to ride on the following: any load, slings, cables, "headache" ball (connected to the whip line or fast line), nor the load block.
- 6.4.16 Only qualified "A" or "B" crane operators (refer to Section 8.0) are allowed to transfer personnel. All other crane operators ("C" crane operators and maintenance personnel), whether MAPP or contractor, are prohibited from transferring personnel.
- 6.4.17 All personnel lifts shall be under power control both up and down.

6.5 Rigging Practices

- 6.5.1 Personnel performing "Rigger" functions or activities shall meet the requirements of Section 9.0 (API RP 2D trained).
- 6.5.2 Sling angles will not be less than 30 degrees from the horizontal (or not more than 60 degrees from the vertical). See Appendix C for proper sling angle calculations.
- 6.5.3 **NO** "field fabricated" slings shall be used.
- 6.5.4 Knots or kinks are not permitted in wire rope or slings for any reason.
- 6.5.5 Slings and wire rope must not be used if they have no certification tag and any excessive amount of wear, damage, flat spots, broken wires, or visual lack of lubrication exist. All slings must be certified and tagged. If any of the above conditions are present, the equipment will be replaced or sent in for inspection, testing, and refurbishment by qualified personnel. All slings that will be permanently placed out of service shall be destroyed and properly disposed of and slings that will be placed out of service temporarily (i.e. recertification process) will be properly tagged "Out of Service".
- 6.5.6 Chains, fiber rope, or "soft line" shall not be used in the place of wire rope slings to lift loads or personnel. Appropriately rated, certified nylon or synthetic webbed slings are acceptable for non-personnel lifts.

- 6.5.7** Wire rope and slings shall not contact any rough cut edges or holes such as pad eyes and shall be padded or properly protected to prevent damage from contact by sharp corners. Shackles must be used with all pad eyes.
- 6.5.8** Hook openings shall be turned outward on hook slings. (see Appendix C)
- 6.5.9** Tag lines shall be used on all lifts. They shall be of sufficient length, diameter, and strength to allow adequate control of the load by the rigger(s).
- 6.5.10** The free end of tag lines should not contain anything that is likely to become snagged during lifting operations (e.g., knots or weights).
- 6.5.11** Tag lines should be connected to the lowest practical point and at right angles on the load whenever possible. If a tag line cannot be attached directly to the load, it must be attached to the shackle end of the sling as near the load as possible.
- 6.5.12** Slings and tag lines must be clear of all obstructions before the signal person and/or rigger divert their attention from the load.
- 6.5.13** At no time are load hooks or lines to be used/lowered underwater. If underwater operations are to be performed, the contractor shall furnish the proper submergible cable/equipment.
- 6.5.14** Shackle information:

There are two types of shackles commonly used in rigging. They are the anchor (bow type) shackle and chain ("D" type) shackle. The pin styles commonly used with shackles are screw pins, bolt pins, and loose pins. Shackles, like most other rigging hardware, are sized by the diameter of the steel in the bow section rather than the pin size.

- Screw pin shackles are to be used when lifting and placing a load. The pin shall be tightened prior to each lift. This type of shackle shall be the preferred method when it will be a temporary connection. The screw pin shackle is capable of being used at full working loads to gather multiple leg slings. It can also be side loaded at a reduced working load limit.
- Bolt type shackles are to be used in permanent or long-term installations. The proper nut and cotter pin shall be used at all times with this type of shackle. The bolt pin shackle is capable of being used at full working loads to gather multiple leg slings. It can also be side loaded at a reduced working load limit.
- ONLY** domestic made Crosby or equivalent high strength alloy steel shackles are to be used in lifting operations (refer to Appendix C).
- ONLY** properly fitted screw pins shall be used in shackles. Never replace the shackle pin with a bolt.
- Shackles should never be used if the distance between the eyes is greater than listed in Appendix C.
- All screw pins must be straight and completely seated in the shackle.
- Shackles worn in the crown or the pin by more than 10% of the original diameter shall be discarded.
- Shackles should never be attached where the load could possibly roll or unscrew the pin during the lifting process.
- Shackle specifications: (see Appendix C)

6.5.15 Drum and Bottle Racks

Drum and Bottle Racks used for transporting drums and pressure cylinders offshore will be designed to appropriately secure and safely transport drums and cylinders. Refer to Appendix G and H for design guidelines.

6.6 Boats, Shorebases and Load Rigging/Marking

- 6.6.1** Dock personnel will examine cargo and refuse to attach or lift any load they judge to be unsafe.
- 6.6.2** It is a recommended practice that loads/equipment delivered to shore-base for shipment offshore be pre-rigged with certified slings/ rigging equipment and configured with a one-point hook up. The one point hook up should be long enough so that a rigger can attach the load to the crane from the deck or ground level.
- 6.6.3** All skid-mounted equipment (e.g., welding machines, air compressors, pumps) that exceeds 1,000 lbs. capacity shall be permanently marked with the maximum weight of the equipment.
- 6.6.4** All cargo containers, such as trash baskets, tool baskets, grocery boxes, drum racks, gas cylinder racks, cutting boxes, sensitive material bins, hazardous material bins, MPT tanks, cutting boxes, tote tanks and portable racks must be permanently marked with the design "gross" weight capacity and "net" (empty) weight.
- 6.6.5** Pallets shall not be used to transport products or equipment to or from offshore facilities. Palletized materials shall be placed in approved cargo containers prior to handling with the crane.
- 6.6.6** MAPP Cargo manifests shall be completed prior to transporting loads to and from offshore and shall include the weight of each piece of cargo.
- 6.6.7** Cargo manifests, showing both the loads and their weights (if over 5,000 pounds), shall be faxed from the shore base to the affected offshore facility and communicated to the crane operator so that he/she may prepare for the lift(s).
- 6.6.8** Boat personnel shall maintain radio communication with the crane operator on the platform at all times while lifts are being made to or from the boat.
- 6.6.9** Boat personnel should direct the placement of each load onto the deck of the boat, taking into consideration balance, actual and anticipated sea conditions, and subsequent load changes. However, the load placement location must not cause the crane operator to exceed the safe working limits of the crane (e.g., exceed safe boom angle). The crane operator shall plan the lifts with the boat crew and refer to the cargo manifest prior to making the first lift.
- 6.6.10** Loads in excess of 5,000 pounds shall be clearly marked on both the load and the cargo manifest before placing the load on the boat. The below color and shape marking labels shall be used. Where possible, the markings should be visible from the crane.

Color	Weights	Shape
Green	Less than or equal to 5,000 lbs	Square
Yellow	5,001 lbs to 10,000 lbs	Octagon
Red	Greater than 10,000 lbs	Octagon

- 6.6.11** Boat lifts shall be made over the water whenever possible. Loads coming from boats shall be raised only high enough to clear the sides (gunwales) of the boat before swinging the load over the water. Loads made to a boat shall be lowered over the water until just before swinging the load over the gunwales.

7.0 INSPECTION AND MAINTENANCE

7.1 Operational Inspections and Maintenance

7.1.1 Prior to starting the crane for the first use of the day, prior to or during each change in operator, and as the qualified operator deems necessary during the day for extended operations or changes to JSA, a **Pre-Use inspection** including the following items will be completed (corrections or repairs will be made before starting the crane and the inspection must be documented on the MAPP Crane Pre-Use Inspection Form).

- Check the boom angle indicator.
- Check fuel level and fill if needed.
- Check engine oil level and fill if needed.
- Check hydraulic fluid levels and fill if needed.
- Move all controls to ensure freedom of movement/operations.
- Test horn, radio, and any other communication equipment (e.g., Gaitronics) for proper operation.
- Check emergency shutdown device(s) for proper position.
- Visually inspect boom, boom components, and boom appendages for damage.

7.1.2 Prior to making the first lift, each crane operator shall inspect the crane for the following items (corrections or repairs should be made prior to making the first lift):

- If the crane is mechanical, check protection sheet metal covers over boom hoists, operating clutches, and brakes to ensure that they are closed/shut and secured. All personnel lifts with a mechanical crane are to be made under power control both up and down.
- Boom up and down to verify proper boom hoist operation and function of boom angle indicator.
- Verify that load line or fast line hook safety latches are in good working order.
- Verify proper function of swing capability.
- Verify that both auxiliary and main hoist hooks swivel properly on the block to prevent the cable from twisting.
- Inspect rigging equipment that will be used for impending lifts to verify condition and the presence of tags where appropriate.
- Consult cargo manifest to identify weight of the load.
- Test horn, radio, and any other communication equipment (e.g., Gaitronics) for proper operation.
- Check emergency shutdown device(s) for proper position.
- Visually inspect boom, boom components, and boom appendages for damage.

7.2 Mechanical (Preventive) Inspections and Maintenance

Cranes will be kept clean, lubricated and free of rust. Corrosion, not mechanical failure, often results in major component change; there is no excuse for this occurrence. The new API standards set inspection intervals according to the number of hours the crane is operated.

All cranes will be inspected Monthly by a qualified (Class A or B) crane operator regardless of usage category. The crane will be started, boomed up and down, swung 360 degrees, hoists operated and safety devices tested. This task performance will help keep critical components from sticking and/or freezing up. All Monthly inspections will be documented on the MAPP Crane Inspection form. All deficiencies noted shall be repaired immediately.

Maintenance procedures are spelled out clearly for each inspection interval within the inspection guidelines. The operator, mechanic and inspector are each responsible for certain tasks. Each person will carry out his or her duties as prescribed.

Running wire ropes will be changed every three years or sooner depending upon condition indicated by inspection.

Pendant lines will be changed every eight years or sooner depending upon condition indicated by inspection.

Slings (Wire and Synthetic/Nylon) will be replaced every five years or sooner depending upon condition indicated by inspection.

Slings should be stored in areas where they will not be exposed to excessive amounts of water, extreme heat, or corrosive fumes, liquids/sprays. Slings should not be stored on the deck. All slings, when not in use, should be kept on a rack and secured properly to prevent abrasion due to rubbing and maintained in a manner to minimize corrosion. Synthetic or Nylon type slings should also be stored out of direct sunlight and away from excessive heat and chemicals. All rigging components shall be inspected daily before use and documented at least annually.

Only domestic wire rope shall be used unless other products are specified by the original equipment manufacturer.

Repairs will be done by qualified individuals and recorded in the crane maintenance file.

Qualified field mechanics may perform certain maintenance tasks on a crane. The extent of which the maintenance will be performed will be dictated by the mechanics' experience, training and familiarity with the machine.

Examples of such maintenance are:

- Engine Preventive Maintenance and Repair
- Lubrication of components

Qualified Crane Service Technicians shall conduct the following:

- Quarterly Inspections
- Annual Inspections
- Hydraulic System Repairs / Changes (i.e. filter changes, hose changes, control valve linkage repair)
- Boom section replacement including heel pins
- Winch and Wire Rope Replacements
- Pedestal bearing repair
- Control valve service

7.2.1 Mechanical (preventative) inspections and maintenance shall be performed in accordance with API documents RP 2D and Spec 2C and manufacturer's recommendations.

7.2.2 NO Welding repairs shall be made to critical components, such as booms and swing circle assemblies, without specific repair procedures and recommendations from the original Crane Manufacturer, or other qualified source (such as a API-licensed 2C Crane manufacturer, Authorized Surveyor, or an engineer experienced in the design of the crane, as determined by the Crane Owner). Care should be taken to ensure that arcing does not occur across any bearings. Crane repairs shall not be conducted without Crane Maintenance Foreman approval.

7.3 Required Inspections

Category	Usage	Inspection Type
Infrequent	10 hours or less	Pre-Use, Monthly Annual
Moderate	50 hours or less	Pre-Use, Monthly Quarterly, Annual
Heavy	50 or more hours	Pre-Use, Monthly, Quarterly and Annual

Inspections will occur according to usage hours based on a three-month average with the exception of Monthly inspections which will be conducted on all cranes regardless of usage category. (API RP-2D – 4.1.1) Usage hours are defined as actual operating hours or “stick time”. Usage hours do not include engine idle time.

The usage ratings, rating hours and required inspections are as follows: (based on 3 month average)

In addition to the requirements of API RP 2D, all cranes, regardless of usage level, will be given **Pre-Use and Monthly** inspections by the qualified crane operator. Pre-Use inspections will be performed before daily usage and more frequently if the crane is used on a continuous basis or if deemed necessary by the qualified operator. “Daily” means a 24-hour period beginning at 12:00a.m. of one day and ending at 12:01a.m. the next day. Pre-Use inspections will also be performed at each operator shift change. Class C Crane Operators may not perform any crane inspections (pre use, monthly, etc.) unless under direct supervision of a Class A or B Crane Operator.

Pre-use inspections will be documented on the MAPP Crane Pre-Use Inspection Form.

Monthly inspections will be performed by a qualified crane operator (Class A or B) once per Calendar Month and must be documented on the MAPP Monthly Crane Inspection Form.

Special attention will be given to “noted” discrepancies with communication to the Foreman and/or Mechanic on duty upon discovery. Pre-Use inspection forms will also be used to record operating hours (actual usage – not engine idle time).

Inspectors for Initial, Annual and Quarterly inspections will be provided by a Third Party Crane Service Company and the Inspector/mechanic must be “Qualified” as stated in API RP-2D 2.2.

“Qualified” crane operators (API RP-2D 2.1 and 4.1.2) will perform “Pre-Use” and “Monthly” inspections.

A Subcontractor Supervisor’s signature must be on all inspection forms. This signature denotes acceptance of the inspection, forms are filled out correctly and assures discrepancies are being resolved (parts are on order). A copy shall be provided to the MAPP Superintendent.

7.4 Deficiencies

Deficiencies are defined as “conditions that in any way compromise the proper performance and/or safe operation of the crane”.

Upon inspection, minor deficiencies will be recorded and repaired on the spot or within a short time period (2 weeks).

Placing Crane Out Of Service

A Crane will be tagged “Out of Service” at the operator controls and rendered inoperable, if a major deficiency cannot be corrected immediately. Refer to MAPP’s Tagout Procedures if necessary to assure crane is properly placed out of service and rendered inoperable. A crane may be rendered inoperable by disabling the start system. Notify MAPP Superintendent immediately if a crane is tagged “Out of Service”

or is de-rated upon inspection.

If a crane is de-rated a new “temporary” load chart must be obtained from a certified engineer and posted in the cab and a record of it kept on file. There must also be a sign posted at the operator’s station stating, “This Crane is De-Rated ___%” during the period of this status.

To place either the auxiliary or main winch out of service and still allow the crane to continue operating, the following procedures shall be followed.

- 1 The control lever linkage must be physically detached between the control lever and the control valve.
- 2 Both hydraulic hoses at the winch motor must be removed and caps must be placed on the motor connections and plugs must be installed on the ends of each hose.
- 3 MAPP’s Tagout procedure must be followed.

In the event that all of the above items cannot be done properly and simultaneously, the entire crane must be placed out of service until repairs are made. If there are any questions regarding these procedures, the MAPP Superintendent must be notified.

7.5 Records

Records of inspections, maintenance, load tests, pull tests, operational tests and sling and cable certifications will be kept in a single file folder on the platform where the crane resides, if physically possible, for four years (API RP2D 4.2.2). Current Pre-Use inspections can be kept on/in the crane or about the crane (out of the weather) or in the platform office. (API RP2D 3.1.3.k.1.o). Aged pre-use inspections will be kept in the crane file.

Work Orders will be initiated for any and all work performed.

A list of current qualified crane operators will be kept on the main facility.

A sling inventory will be performed once a month verifying tags or other identification on the slings, and, that related certification documents are filed on location.

A running rope record and associated certification documents will be kept for each crane in its respective crane file.

7.6 Load Test and Pull Test (as per API RP2D Latest Incorporated Edition)

7.6.1 Load Test: is defined as a load that is applied to the crane structure at 125% of the crane’s static rated capacity as identified on the crane’s load chart. A load test is required under the following conditions:

1. New cranes being placed into service.
2. Cranes that are being permanently relocated.
3. Temporary cranes after each rig-up or relocation. NOTE: A Pre and Post Annual Inspection is required during Load Test process.

7.6.2 Pull Test: is defined as a load that is applied to the crane structure that will not exceed 100% of the crane’s static rated capacity as identified on the crane’s load chart. A pull test is conducted at the owner or owner representative’s discretion. This is **NOT** a load test. When the crane owner or owner’s representative elects to have a crane pull-tested, a calibrated dynamometer or a known suspended weight should be used and the pull test should be held for a minimum of 5 minutes. Upon completion of the pull test, a qualified operator or qualified inspector should perform a pre-use inspection of the crane to assure no damage occurred during the test.

8.0 CRANE OPERATOR QUALIFICATIONS PROCEDURES

NOTE: In order to operate any offshore crane installed on MAPP controlled property, the crane operator must meet the following criteria and qualifications:

8.1 Physical Requirements

8.1.1 Anyone operating the crane for the purpose of making lifts must meet the following physical requirements as per API RP 2D and must be re-evaluated every four years and as physical conditions change. If cranes will be operated by contract personnel, the contractor's employer will be responsible for verifying the following physical requirements are met during the crane operator qualification process.

- Have vision of at least 20/30 Snellen in one eye and 20/50 in the other, with or without glasses, and have depth perception.
- Be able to distinguish red, green and yellow, regardless of position of colors, if color differentiation is required.
- Have adequate hearing.
- Have no history of a heart condition, epilepsy, dizziness, fainting spells, nervous disorders, or any other disabling medical condition that may interfere with the safe operation of a crane. Exceptions to this statement will be considered on a case-by-case basis, with a physician's approval, and with the review and approval of MAPP Management.
- Have received a medical evaluation prior to being authorized to operate any crane and a follow-up evaluation at least every four years. Medical evaluations shall include at minimum the following:
Physical Qualifications For Equipment Operators (Figure 2) or equivalent and
A satisfactory drug and alcohol screen as provided by Occupational Health Services Department.

8.1.2 All personnel operating a crane for the purpose of making lifts must notify their immediate supervisor whenever their physical condition changes or if changes in medications could, in any way, interfere with their ability to safely operate the crane.

8.2 API RP 2D Training Requirements

8.2.1 Crane operators must attend and pass a training course based on the requirements contained in API RP 2D before they can be issued an initial Qualification card. Appropriate refresher training will be conducted at a minimum of every (4) years. If cranes will be operated by contract personnel, the contractor's employer will be responsible for verifying the following training requirements and other criteria are met during the crane operator qualification process.

- Rigger training as outlined in API RP2D.
- A written test which attendees must pass in order to obtain crane operator qualification and rigger qualification.

8.3 Crane Operator Training and Qualifications Program

Before a crane operator can operate a crane on a MAPP project, he or she must meet the above mentioned requirements (Section 8.1 and 8.2) and successfully complete a Crane Operator Training and Qualifications Program. The MAPP Crane Operator Training and Qualifications Program will be administered by a Qualified Instructor and will consist of the following:

8.3.1 Verify crane operator possesses a valid API RP 2D qualifications card as stated in Section 8.2.

8.3.2 Complete review and training of MAPP’s Offshore Crane Operation and Maintenance Program.

- Acknowledgement sheet at the beginning of this program shall be signed by the operator and filed on the facility. A log of the personnel acknowledgements shall be maintained by the qualified instructor.

8.3.3 A test and a hands-on evaluation of each candidate’s operating proficiency shall be administered by an MAPP approved qualified instructor on the type of crane (hydraulic, mechanical or both) to be operated by that candidate.

8.3.4 Based on the results of the hands-on evaluation, operation experience and classroom test results, the operator will be classified as follows:

Crane Operator Classification Table

Class	Operating Limitations
Class A	<input type="checkbox"/> No limitations except those imposed by the weather, seas or other unsafe conditions
Class B	<input type="checkbox"/> May not lift over 75% of the rated crane capacity at any given angle. <input type="checkbox"/> May be limited in certain conditions imposed by the weather and/or sea state
Class C	<input type="checkbox"/> Must be under direct supervision (within arm’s length) of a Class A or B Crane Operator. <input type="checkbox"/> May not lift more than 50% of the rated crane capacity at any given angle. <input type="checkbox"/> May be limited in certain conditions imposed by the weather and/or sea state. <input type="checkbox"/> May not lift personnel. <input type="checkbox"/> May not perform any crane inspections (pre use, monthly, etc.) unless under direct supervision of a Class A or B Crane Operator

8.3.5 The MAPP Crane Operator Classification can be changed after the operator has been reevaluated as per sections 8.3.4 and 8.3.5 of this program.

8.3.6 All training and qualification records shall be maintained on the platform for each qualified crane operator.

8.4 Suspension of the Ability to Operate Crane

8.4.1 An employee or contractor shall be suspended from operating a crane if any of the following conditions occur:

- Expirations of his or her API RP 2D qualifications card (every 4 years)
- Physical/medical condition has changed which may impair his or her operations
- Poor or unsafe operations of a crane.

8.5 All employees who work with offshore operations shall be trained on the MAPP Offshore Crane Operation and Maintenance Program upon assignment to such job duties and at least bi-annually thereafter.

9.0 RIGGER QUALIFICATIONS

9.1 Physical Requirements

Anyone serving as a "Rigger" for purposes of attaching loads prior to making lifts with cranes on MAPP controlled premises must have adequate physical capabilities (e.g., vision, hearing, etc.) to safely execute those duties expected of him/her.

9.2 Training Requirements

9.2.1 All "Riggers" (whether MAPP or contractor) must have knowledge of the basics of safely rigging loads through an approved API RP2D structured rigging school and experience. This training should be equivalent to the rigger orientation required of certified crane operators in Section 8.2.

9.2.2 Load rigging practices must follow all API recommendations and standard industry procedures.

9.2.3 Anyone serving as a "Rigger" shall have attended an approved API RP2D structured rigging school and read and be familiar with Section 6.3. This shall include riggers on board crew boats or supply boats where loads from platform cranes are being rigged for loading and unloading.

10.0 OVERHEAD/PORTABLE HOIST OPERATING PRACTICES, PROCEDURES, AND REQUIREMENTS

10.1 Hoisting Equipment

This section applies to all overhead/portable hoists including those operated by hand, by electricity, or by pneumatics. All operations, including maintenance operations, shall be performed in a safe manner. At a minimum, this shall include the following:

10.1.1 The hoist operator shall inspect the immediate area, hoist, associated rigging, and the load prior to making a lift. Deficiencies that could jeopardize the lift shall be corrected prior to making the lift.

10.1.2 No part of the hoisting system shall be overloaded. This includes the beam upon which the hoist rides, the hoist itself, the lifting chain and hook, and any slings or shackles associated with the lift. The support beams should be marked with the load limitation.

10.1.3 All personnel must be clear of the load before it is lifted.

10.1.4 Lifts may not travel over personnel.

10.1.5 Upon lifting, the load hook shall be positioned directly over the load prior to making the lift.

10.1.6 The hook must have a properly functioning safety latch.

10.1.7 Proper personal protective equipment (PPE) must be worn during all hoisting operations.

10.2 Rigging Practices

10.2.1 Rigging equipment must be appropriate for the job.

10.2.2 Shackles must conform to the requirements listed under Section 6.5.15 of this policy.

10.2.3 Slings must conform to the requirements listed under Section 6.3 of this policy.

10.2.4 Chains will be used with hooks, and hooks will be locked with latches or wire to prevent loosening.

10.3 Hoist Inspection and Maintenance

10.3.1 The load chain and hook shall be inspected daily or prior to each use, if used infrequently. The inspection should identify problems that could adversely affect the lifting operation.

10.3.2 The hoist brake should be checked at the start of each lift by hoisting the load a few inches and watching to see if the brake holds. If the load does not drift downward, the lift may be continued. If the load does drift downward, the brake must be repaired before continuing the lifting operation.

10.3.3 All parts of the pneumatic system should be checked for leakage prior to making the lift.

10.3.4 The lifting controls should be checked for smooth and proper operation. This applies to the hand chain on manually operated hoists as well as the controls on electrically or pneumatically operated hoists.

10.4 Air Tuggers/Hoist/Winch

10.4.1 Only those personnel who are trained in the safe operation of this equipment shall be allowed to conduct the operations of this equipment.

10.4.2 Operators of this equipment shall have good hearing, vision and depth perception. This is to be documented by the contract company.

10.4.3 Prior to using this equipment a visual inspection shall be conducted, by the operator, to ensure there are no signs of wear and/or other damages.

10.4.4 Keep hands, clothing, etc., clear of moving parts. Never place your hand in the throat area of a hook or near wire rope which may be spooling onto or off of the winch drum.

10.4.5 This equipment is not approved to be used for lifting, supporting, or transporting personnel.

10.4.6 Loads shall not be lifted or supported over personnel.

10.4.7 The supporting structures and load attaching, or lifting, devices used with this equipment shall provide adequate safety factors to handle the rated load, plus the weight of the equipment.

10.4.8 During lifting operations ensure that the loads path is clear of obstructions.

10.4.9 No load shall be left unattended.

10.4.10 All loads shall contain a tag line of proper length.

10.4.11 The operator should have continuous eye contact with the load during the entire lift. If this can not be accomplished a signal person shall assist the operator to ensure a safe lift is executed. (NOTE: Signals need to be discussed during the pre-job meeting.)

10.4.12 Do not jerk, swing or side-pull the load.

10.4.13 Prior to leaving the area the operator shall bleed off the air supply and ensure that all emergency stop controls are in place.

10.4.14 The equipment shall be operated in a slow controlled manner.

10.4.15 During operations the drum shall have at least three tight wraps of wire rope on it at all times.

10.4.16 During operations do not allow the wire rope to spool incorrectly.

10.4.17 Always use proper PPE when handling wire rope. (Ex: Leather gloves)

10.4.18 Always use approved, certified rigging equipment.

10.4.19 Anyone who attaches or detaches lifting equipment to loads or lifting devices shall be trained in accordance with API RP 2 D.

10.4.20 Do not attach a welding electrode to the equipment or the wire rope.

10.4.21 Never run the wire rope over a sharp object.

10.4.22 Do not use wire rope as a ground for welding.

10.4.23 Installation: a) Prior to installation, inspect the equipment for damages. b) Do not weld to the base or any part of the equipment. c) Proper mounting brackets shall be securely attached to the equipment. which will

then allow the assembly to be welding to the deck. d) The mounting surface shall be level and of sufficient strength to handle the rated load plus the weight of the equipment.

10.4.24 Please refer to the manufacturer and maintenance manuals for air tuggers/hoist/winches for a more detail description of how to operate, maintain, inspect and install this equipment properly.

NOTE: If you have any questions or concerns about the operations, maintenance, inspection or installation of this equipment please consult your supervisor or your EH&S Representative.

11.0 CONTRACT/RENTAL CRANES

This section applies to all cranes provided to MAPP on a contract basis. This includes liftboat cranes and portable rental cranes (excluding derrick barges).

11.1 Jack-Up Boats

11.1.1 All cranes on board jack-up boats that are contracted to MAPP will be required to follow the inspection, maintenance and operating requirements of USCG or other applicable government regulations.

11.2 Rental Cranes

11.2.1 Due to the reassembly nature of rental cranes, a pre and post annual inspection and load test should be conducted by a qualified inspector at each new crane setup.

11.2.2 Load test shall consist of a dynamometer pull in each quadrant of lift to ensure safety of crane and its foundation.

11.2.3 Rental cranes shall be operated and maintained in accordance with API RD 2D and MAPP's Offshore Crane Operations and Maintenance Program.

APPENDIX A**FIELD SUMMARY****OBJECTIVE**

The Offshore Crane Operation and Maintenance Program contains detailed guidelines deemed necessary to ensure safe crane operations at offshore MAPP facilities. This policy applies to all cranes used in conjunction with all MAPP offshore operations.

The details of this policy must be familiar to, and complied with, by all contractors, foremen, crane operators and maintenance personnel working on offshore cranes. Failure to comply with all the provisions herein may result in disciplinary action for those parties involved.

PROCEDURES

All crane operations on MAPP operated facilities shall be conducted in accordance with the latest editions of the most appropriate API Recommended Practices 2D. See Section 4.0.

- A. Equipment (including slings and shackles) shall not be overloaded or used in an unsafe manner. All necessary maintenance and inspection precautions as specified in the above referenced documents shall be adhered to. See Section 6.0 and 7.0.
- B. Crane Operators shall meet the minimum specified physical requirements and have passed the required qualification process. See Sections 8.0.
- C. Rigging operations must conform to the standard industry safe practices (as contained in Section 6.0) and be performed by personnel that meet the minimum requirements of Section 9.0.
- D. Cargo exceeding 5,000 pounds shall be clearly marked on both the load and the cargo manifest prior to placing the load on any boat. Manifests shall be faxed to/from the shorebase and affected facility before the load is sent onward. See Section 6.6.
- E. Overhead/Portable Hoists shall be operated and maintained in accordance with the provisions of Section 10.0. All operators of overhead/portable hoists must read and understand this policy prior to the operation of an overhead/portable hoist.
- F. All crane operations must be conducted in accordance with MAPP Offshore Safe Operating Procedures. This includes the use of all required PPE, Job Safety Analysis and Stop Work Authority.

APPENDIX B

CRANE TERMINOLOGY

- 1 CRANE BOOM
- 2 BOOMHEAD SHEAVE ASSEMBLY
- 3 JIB
- 4 FLOATING HARNES OR BRIDLE
- 5 GANTRY OR A-FRAME
- 6 REVOLVING SUPERSTRUCTURE
- 7 SWING CIRCLE OR ROLLER PATH
- 8 BOOM FOOT PIN
- 9 JIB MAST
- 10 BOOM SPLICE BOLTS OR CONNECTORS (TYPICAL)
- 11 FOUNDATION BOLTS OR FASTENINGS
- 12 CRANE BASE OR PEDESTAL
- 13 JIB FRONT STAY LINES
- 14 PENDANTS, GUYS, OR BOOM BACKSTAYS
- 15 DERRICKING, OR RUNNING BOOM HOIST ROPE
- 16 JIB BACKSTAY LINES
- 17 JIB OR AUXILIARY HOIST LINES
- 18 JIB OR WHIPLINE HOOK
- 19 MAIN HOIST LINE
- 20 MAIN LIFT HOOK BLOCK
- 21 LIFTING TACK

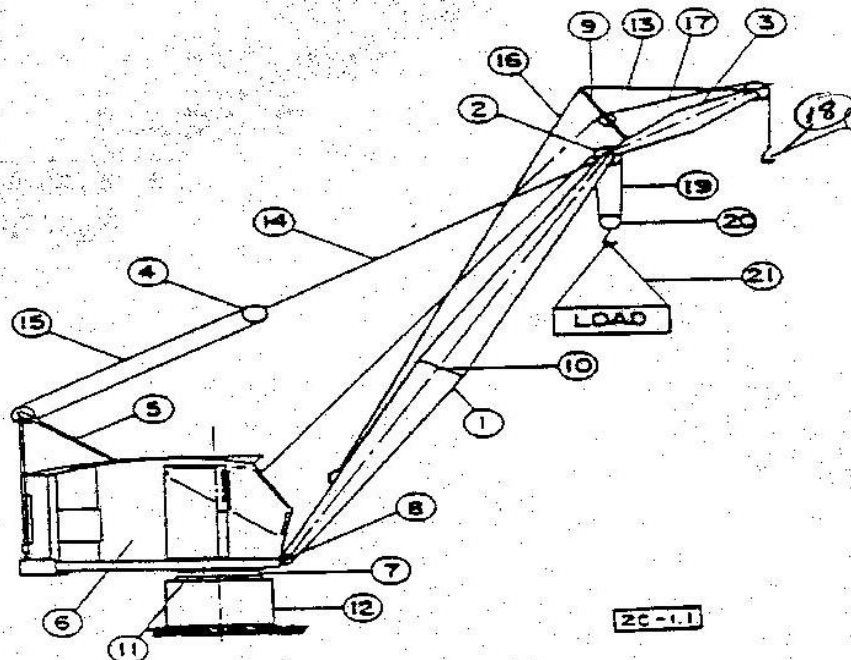

FIG. 1.1
CRANE ASSEMBLY

APPENDIX C

RIGGING SPECIFICATIONS AND INFORMATION

GOOD AND BAD RIGGING PRACTICES

Use of Chokers

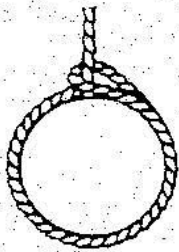

Bad — Because of cutting action of eye splice on running line.

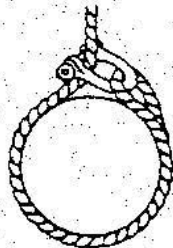

Bad — Bolt on running line can work loose.

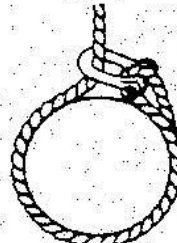

Good

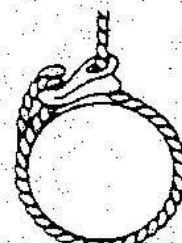

Good

No cutting action on running lines.

Eye Fittings

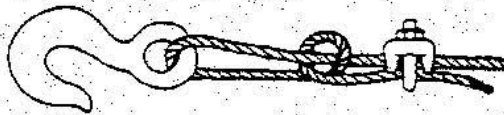

Bad Practice
Wire rope knot with clip. Efficiency 50% or less.

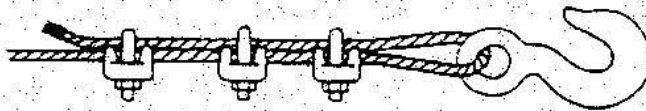

Bad Practice — Thimble should be used to increase strength of eye, reduce wear on rope and obtain maximum efficiency of attachment.

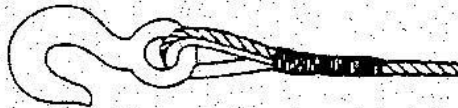

Good Practice — Note use of thimble in eye splice.

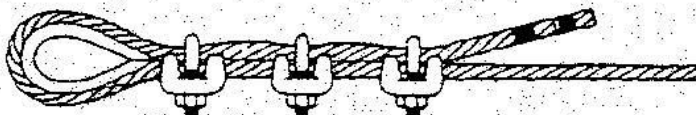

Good Practice — Use of thimble eye.

Hook Slings

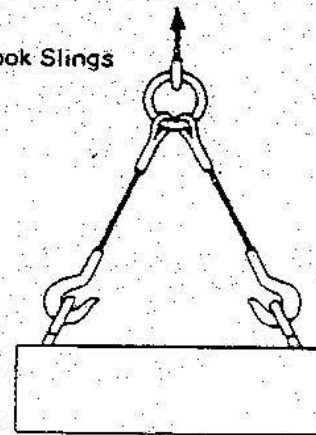

Bad Practice — Hook openings should be turned out.

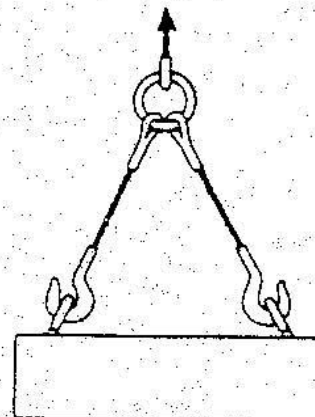

Good Practice — Hooks are turned out.

APPENDIX C – Continued

The U-Bolts of all clips should always be on the short (dead) end of the rope. Tighten nuts evenly to manufacturers' recommended torque. Before lifting be sure that all clips have been torqued. After several lifts, retorque all clips. For wire rope sizes not shown in Table H-20 follow clip manufacturers recommendations.

NUMBER AND SPACING OF U-BOLT WIRE ROPE CLIPS*

Improved plow steel, rope diameter inches	Number of clips		Minimum spacing (inches)
	Drop forged	Other Material	
1/2	3	4	3
5/8	3	4	3 3/4
3/4	4	5	4 1/2
7/8	4	5	5 1/4
1	5	6	6
1 1/8	6	6	6 3/4
1 1/4	6	7	7 1/2
1 3/8	7	7	8 3/4
1 1/2	7	8	9

*Table H-20. OSHA Safety and Health Regulations for Construction.

RIGHT METHOD

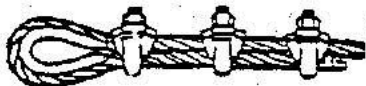

CORRECT METHOD: U-Bolts of Clips on short end of rope.



CORRECT METHOD (with Clips removed): No distortion on live end of rope.

WRONG METHODS



WRONG: U-Bolts on live end of rope.



WRONG: Note mashed spots on live end of rope.



WRONG: Staggered Clips: two correct and one wrong.



WRONG: Note mashed spot due to U-Bolt of center clip.

APPENDIX C – Continued

TYPICAL MANUFACTURERS* RECOMMENDED METHOD OF APPLYING CLIPS TO GET MAXIMUM HOLDING POWER OF THE CLIP

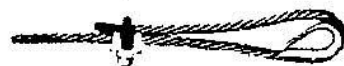
1 

Turn back the specified amount of rope from the thimble. Apply the first clip one base width from the dead end of the wire rope (U-bolt over dead end – live end rests in clip saddle). Tighten nuts evenly to recommended torque.

2 

Apply the next clip as near the loop as possible. Turn on nuts firm but do not tighten.

3 

Space additional clips if required equally between the first two. Turn on nuts – take up rope slack – tighten all nuts evenly on all clips to recommended torque.

4 NOTICE!

Apply the initial load and retighten nuts to the recommended torque. Rope will stretch and shrink in diameter when loads are applied. Inspect periodically and retighten.

Clip Size Inches	Minimum No. of Clips	Amount of Rope to Turn Back in Inches	Torque in Ft. Lbs.
3/8	2	3 1/4	
1/2	2	3 3/4	
5/8	2	4 3/4	15
3/4	2	5 1/4	30
7/8	2	6 1/2	45
1	2	7	65
1 1/8	3	11 1/2	65
1 1/4	3	12	95
1 3/8	3	12	95
1 1/2	4	18	130
1 5/8	4	19	225
1 3/4	5	26	225
1 7/8	6	34	225
2	6	37	360
2 1/8	7	44	360
2 1/4	7	48	360
2 3/8	7	51	430
2 1/2	7	53	590
2 5/8	8	71	750
2 3/4	8	73	750
2 7/8	9	84	750
3	10	100	750
3 1/8	10	105	1200

If a greater number of clips are used than shown in the table, the amount of rope turn-back should be increased proportionately.

A termination made in accordance with the instructions, and using the number of clips shown has an approximate 80% efficiency rating. This rating is based upon the catalog breaking strength of wire rope. If a pulley is used in place of a thimble for turning back the rope, add one additional clip.

The number of clips shown is based upon using right regular or Lang lay wire rope, 6x19 class or 6x37 class, fibre core or IWRC, IPS or XIPS. If Seale construction or similar large outer wire type construction in the 6x19 class is to be used for sizes 1 in. and larger, add one additional clip.

The number of clips shown also applies to right reg-

*Varies with individual manufacturers

ular lay wire rope, 8x19 class, fibre core, IPS, sizes 1 1/4 in. and smaller; and right regular lay wire rope, 8 x 7 class, fibre core, IPS or XIPS, sizes 1 1/4 in. and smaller.

For other classes of wire rope not mentioned above, it may be necessary to add additional clips to the number shown.

IMPORTANT! Failure to make a termination in accordance with aforementioned instruction, or failure to periodically check and retighten to the recommended torque, will cause a reduction in aforementioned efficiency rating.

APPENDIX C – Continued

The Crosby Group, Inc.
Alloy Screw Pin Anchor Shackle

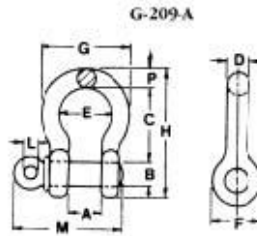

G-209-A
Screw pin anchor shackles meet the performance requirements of Federal Specification RR-C-171D Type IVA, Grade B, Class 2, except for those provisions required of the contractor.

- Working Load Limit permanently shown on every shackle.
- Forged Alloy Steel — Quenched and Tempered, with alloy pins.
- shackles can be furnished proof tested with certificates to designated standards, such as ABS, DNV, Lloyds or other certification. Charges for proof testing and certification available when requested at time of order.
- Hot Dip galvanized.

Nominal Size (in.)	Working Load Limit* (tons)	G-209-A Stock No. Galv.	Weight Each (lbs.)
3/8	2.0	1017450	.31
7/16	2.6	1017472	.38
1/2	3.3	1017494	.63
5/8	5.0	1017513	1.38
3/4	7.0	1017538	2.25
7/8	9.5	1017560	3.61
1	12.5	1017582	5.32
1 1/8	15.0	1017604	7.25
1 1/4	18.0	1017625	9.88
1 3/8	21.0	1017648	13.25

* Note: Maximum Proof Load is 2.5 times the Working Load Limit. Minimum Ultimate Strength is 5 times the Working Load Limit. For Working Load Limit reduction due to side loading applications, see beginning of chapter.

Nominal Size (in.)	Working Load Limit* (tons)	Dimensions (in.)											Tolerance +/-	
		A	B	C	D	E	F	G	H	L	M	P	C	A
3/8	2.0	.66	.44	1.44	.36	1.03	.91	1.78	2.49	.25	2.09	.38	.13	.06
7/16	2.6	.75	.50	1.69	.44	1.15	1.06	2.03	2.91	.31	2.38	.44	.13	.06
1/2	3.3	.81	.63	1.88	.50	1.31	1.19	2.31	3.28	.38	2.69	.50	.13	.06
5/8	5.0	1.06	.75	2.38	.63	1.69	1.50	2.94	4.19	.44	3.34	.69	.13	.06
3/4	7.0	1.25	.88	2.81	.75	2.00	1.81	3.50	4.97	.50	3.97	.81	.25	.06
7/8	9.5	1.44	1.00	3.31	.88	2.28	2.09	4.03	5.83	.50	4.50	.87	.25	.06
1	12.5	1.69	1.12	3.75	1.00	2.69	2.38	4.69	6.56	.56	5.07	1.06	.25	.06
1 1/8	15.0	1.81	1.25	4.25	1.16	2.91	2.69	5.16	7.47	.53	5.59	1.25	.25	.06
1 1/4	18.0	2.03	1.36	4.69	1.29	3.25	3.00	5.75	8.25	.69	6.16	1.38	.25	.06
1 3/8	21.0	2.25	1.50	5.25	1.42	3.63	3.31	6.38	9.16	.75	6.84	1.50	.25	.13

* Note: Maximum Proof Load is 2.5 times the Working Load Limit. Minimum Ultimate Strength is 5 times the Working Load Limit. For Working Load Limit reduction due to side loading applications, see beginning of chapter.

APPENDIX C – Continued

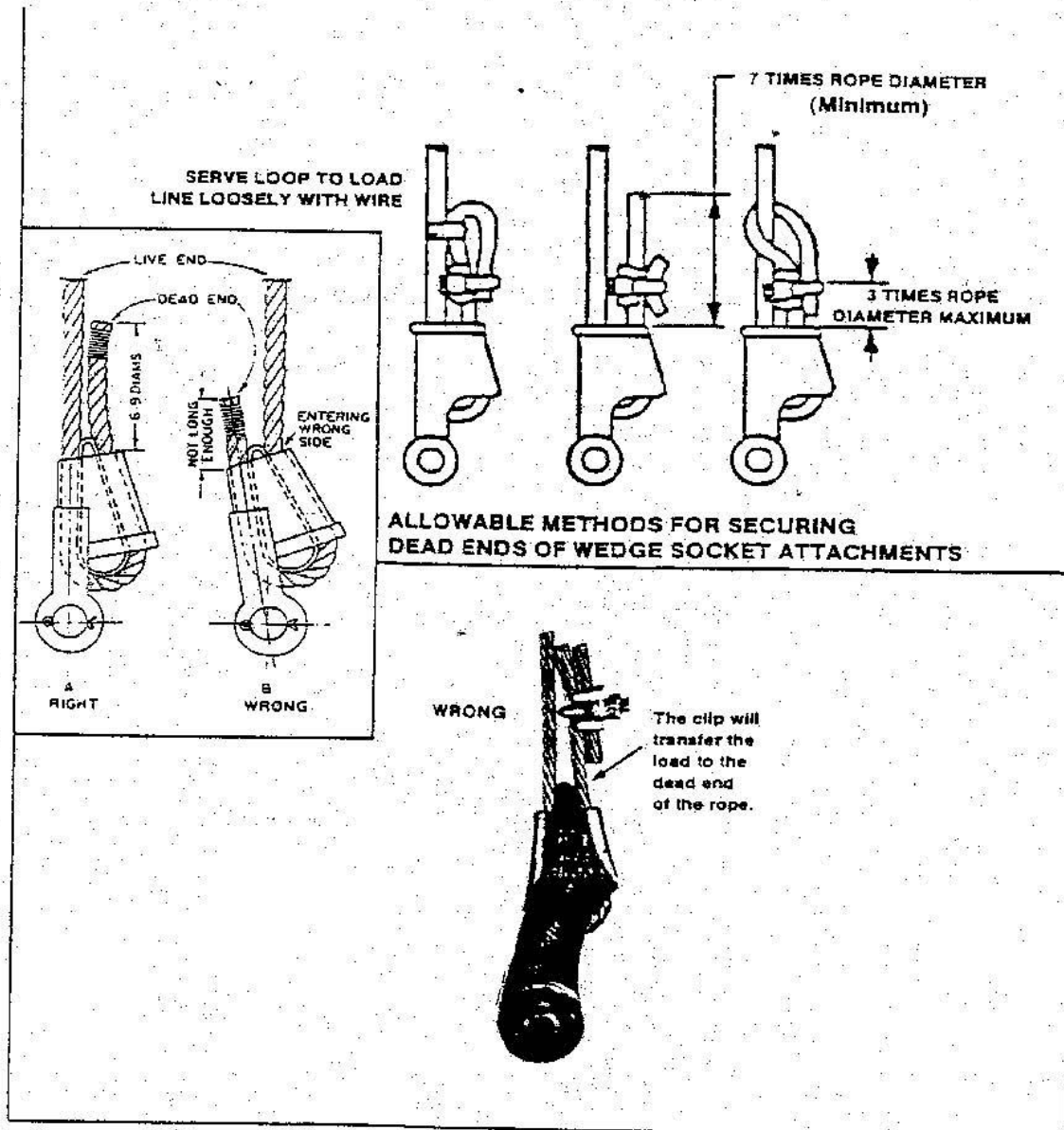

FIGURE 3.10
METHOD OF INSTALLING WEDGE – SOCKET ATTACHMENT

APPENDIX C – Continued

Preferred Shackles

Screw Pin Anchor Style Shackle – these shackles are to be used when lifting and placing a load. The pin shall be tightened prior to each lift. This type of shackle shall be the preferred method when it will be a temporary connection. The screw pin shackle is capable of being used at full working loads to gather multiple leg slings. It can also be side loaded at a reduced working load limit.



Bolt Type Anchor Style Shackle – these shackles are to be used in permanent or long-term installations. The proper nut and cotter pin or stainless steel keeper rings shall be used at all times with this type of shackle. The bolt pin shackle is capable of being used at full working loads to gather multiple leg slings. It can also be side loaded at a reduced working load limit.



APPENDIX C – Continued

Shackle Inspection Areas

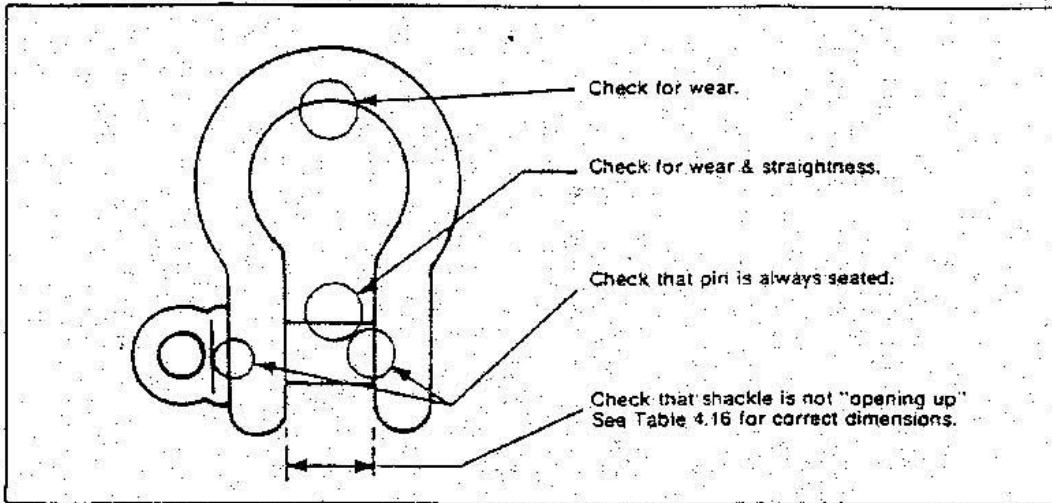

Eccentric Shackle Loads

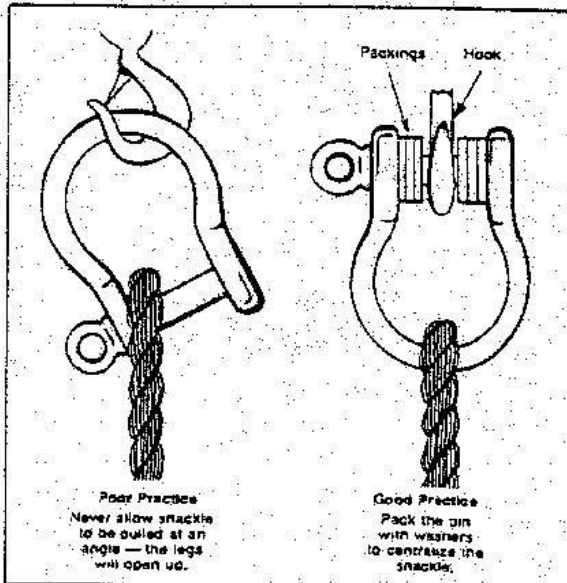

Do Not Use Screw Pin Shackles If the Pin can Roll Under Load and Unscrew

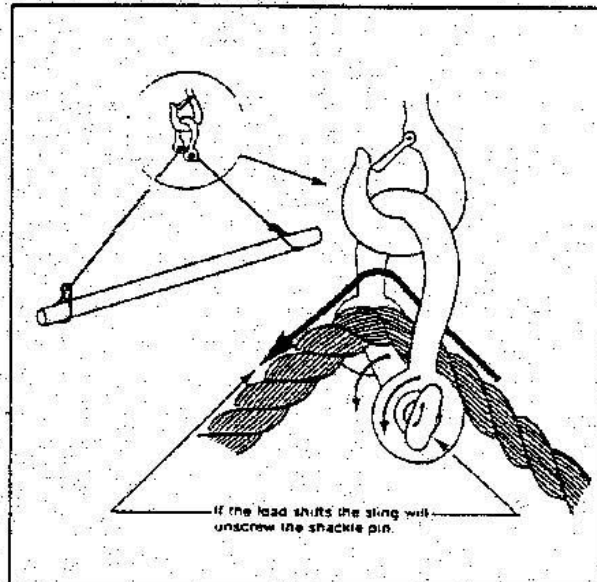

APPENDIX C – Continued

Fig. 4.13 Effect of Sling Angle on Sling Load

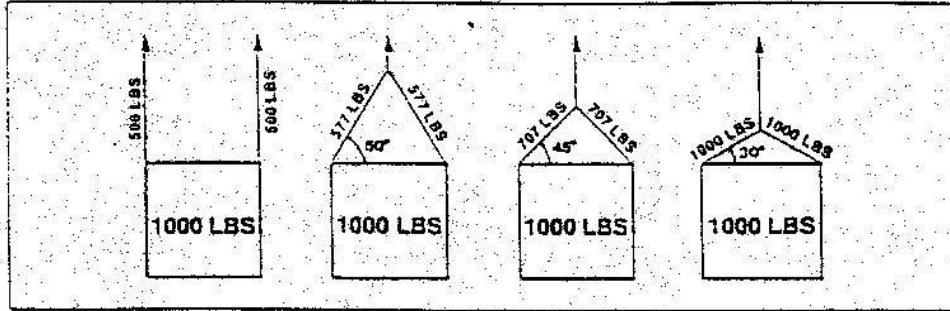
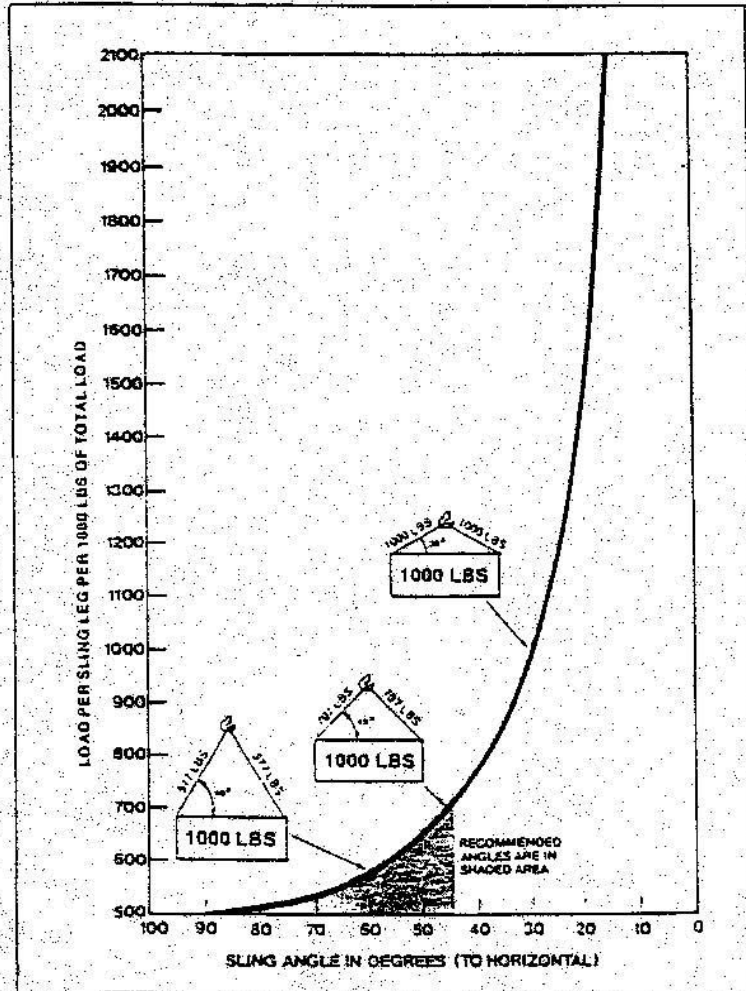
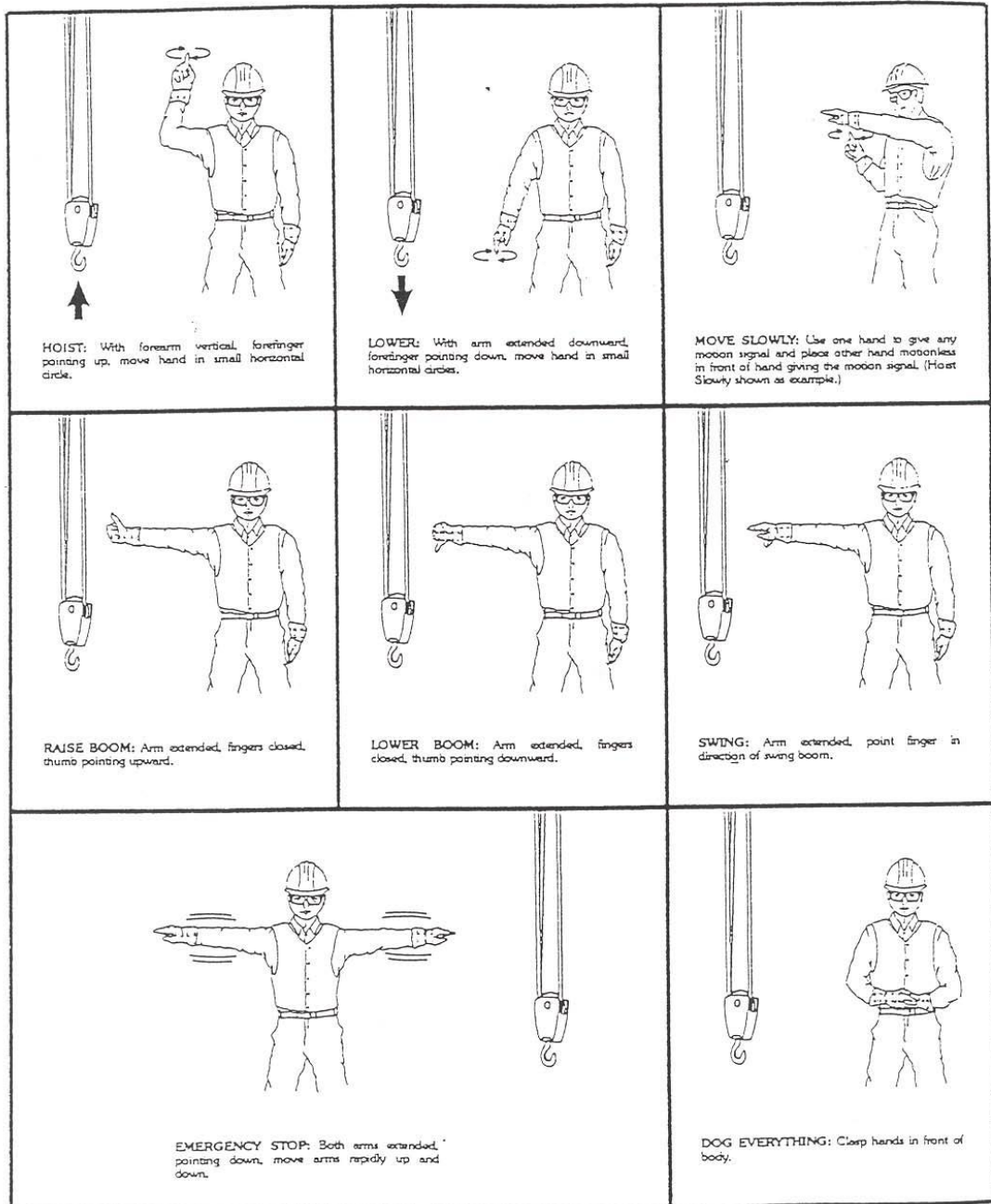

Fig. 4.14 Effect of Sling Angle on Sling Load



APPENDIX D

Figure 1—Standard Hand Signals for Controlling Crane Operations



APPENDIX E

HEAVY LIFT WORKSHEET

Identify the weight of the load to be lifted. _____ Lbs./Tons

Using a platform deck drawing, identify the boom angle, load radius and dynamic capacity from the load chart at the proposed boat or platform location for the initial lift.

Boom Angle _____ □ Radius _____ ft.(A)
Dynamic Capacity at this angle _____

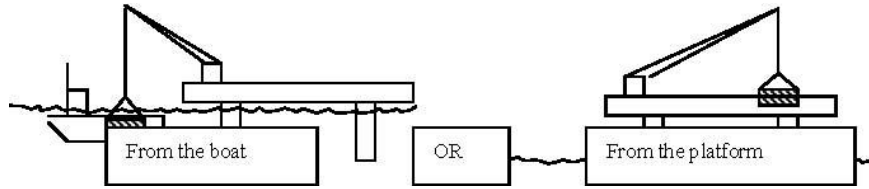

Using a platform deck drawing, identify the boom angle, load radius and dynamic capacity from the load chart at platform location to which the load is to be placed.

Boom Angle _____ □ Radius _____ ft.(B)
Dynamic Capacity at this angle _____

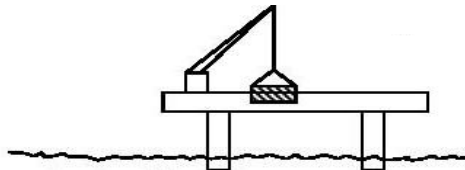

Dynamic capacity at longest radius (A) or (B) _____ - 25% = (C) _____

Weight of load _____

Weight of rigging _____

Weight of tackle _____

Total Weight _____

1. Total Weight _____

2. Adjusted Dynamic capacity (C) _____ (Determining weight)

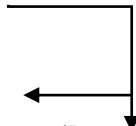

If total weight (1) exceeds the adjusted dynamic capacity (2) the lift is “Heavy”

NOTE: The load radius is determined by measuring the distance from the center of the crane pedestal of the crane to the center of gravity of the load.

APPENDIX F**INSPECTION FORMS**

This appendix contains copies of all the various crane inspection forms. Included are the Pre-Use / Usage, Monthly, Quarterly and Annual Inspection forms which are available on computer. The third party crane inspection company will be required to complete these reports along with their reports and a copy of all will be maintained on file on the platform and with the MAPP Superintendent.

In addition, there is a Self-Inspection Checklist which will be utilized by platform personnel and/or the EH&S Department for evaluating if the guidelines of the MAPP crane program are being met at individual platforms/facilities.

Offshore Crane Operation and Maintenance Program – Inspection Checklist

Project: _____ **Date:** _____ **Inspector:** _____

Operating Practices, Procedures & Requirements		YES	NO	N/A
A1	Are all platform crane operators and riggers certified and documentation provided to MAPP?			
A2	Do contract crane operating personnel and riggers possess a crane card issued in accordance with API RP 2D and have they read the MAPP guidelines?			
A3	Is a list of all qualified crane operators and riggers and their classification kept up to date by the Subcontractor?			
A4	Are Pre-Use Inspections being conducted and kept on file?			
A5	Are all inspection items on the Pre-Use Inspection in operational condition?			
A6	Is the crane inspection / usage file being kept up to date?			
A7	Are all load weights marked or made available to the crane operator?			
A8	Is the "Heavy Lift Worksheet" being used and documented?			
A9	Is the personnel basket in good condition?			
A10	Do crane hooks used for lifting personnel have a positive locking device (not a spring loaded flap or clip)?			
A11	Are all shackles incorporated in a personnel basket lifting configuration tight and wire locked?			
A12	Is the personnel basket equipped with knot-free tag lines?			
A13	Is the personnel basket equipped with a safety "shock" load strap?			
A14	Do all slings have an identification tag attached to them? (See section 7.2)			
A15	Are slings or wire rope free from any excessive amount of wear, damage, flat spots, broken wires, or visual lack of lubrication?			
A16	Are tag lines used on all lifts?			
A17	Are tag lines free from knots or anything else that could hang up?			
A18	Do all shackles meet the requirements stated in this program?			
A19	Are cargo manifests showing both the loads and their weights (if over 5,000 pounds) communicated (faxed/email) from the shore base to the facility so that the crane operator can prepare for the lift(s)?			
A20	Are loads in excess of 5,000 pounds clearly marked so as to be visible from the crane?			
A21	Are cargo manifests sent up to the facility prior to making the first lift from the boat?			
A22	Is crane started, safety devices tested, and crane inspected and documented once per month?			
A23	Have the running ropes been changed at least every three years, the pendant lines and slings at least every five years? Are matching certification documents on location?			
A24	Are all required inspections and maintenance performed as per API RP 2D and Spec 2C?			
A25	Are "Qualified Inspectors" used for required inspections (quarterly, annual)?			
A26	Are inspection deficiencies addressed immediately?			
B	Overhead/Portable Hoists	YES	NO	N/A
B1	Are all parts of the hoisting system, including the beam upon which the hoist rides, the hoist itself, the lifting chain and hook and any slings or shackles associated with the lift, within load limitations?			
B2	Does the hook have a properly functioning safety latch?			
B3	Do shackles and slings conform to the same criteria used for cranes?			
B4	Are chains used with hooks and are the hooks locked with latches or wire to prevent loosening?			
B5	Is the hoist brake checked at the start of each lift?			
B6	Are all parts of the pneumatic system checked for leakage prior to making a lift?			
B7	Do the lifting controls, including hand chains on manually operated hoists as well as the controls on electrically or pneumatically operated hoists, operate smoothly and properly?			

REMARKS: _____

APPENDIX G

Offshore Drum Rack Design Guidelines

1. All drum racks are to be of sound and workmanlike construction, free of defects.
2. All racks will be built to be inherently stable and not easily tipped on side.
3. All racks will have individual drum securement provisions.
4. Drums shall be properly secured at both top and bottom.
5. MAPP Shorebase and Offshore personnel retain the final decision as to rack acceptance/non-acceptance.

Drum racks that do not meet this criteria will be removed from MAPP property and returned to the contractor at their expense.

APPENDIX H**BOTTLE RACK DESIGN GUIDELINES***Guidelines for Acceptance of Compressed Gas Cylinder Racks being Shipped Offshore*

The following criteria is provided to assist shore based and offshore facility personnel in the determination to accept bottle racks carrying compressed gas to MAPP offshore controlled facilities:

1. All bottle racks to be of sound and workmanlike construction, free of defects.
2. All racks that are greater than 6 ft. in length will have 2 lifting pad/eyes or lifting hook arrangements for hoisting unit.
3. All racks will be built to be inherently stable and not easily tipped on side.
4. All racks will have individual bottle securement provisions.
5. Bottle keeping bars should be secured by railing or channel slotted into the rack frame held in place by non-load bearing nut/bolt threaded arrangements or safety pins.
6. T-handle bolts or nuts are not acceptable.
7. Gas cylinders should be secured both top and bottom.
8. Racks transporting both Oxygen and Acetylene cylinders will have firewall barriers between the two types of gas bottles.
9. Chain can be utilized only as secondary securement for bottles in any rack.
10. Bottle racks containing manifolded cylinders will be equipped with overhead dropped object protection.
11. Bottle racks that will be sent offshore shall not have caster wheels attached to the bottom of the racks.
12. Compressed gas cylinder racks that do not meet these criteria will be removed from MAPP property and returned to the contractor at their expense. MAPP personnel retain the final decision as to rack acceptance/non-acceptance.

APPENDIX I

High Angle Boom Kick Out Visual Guidance



High angle boom kick out authorization procedure:

- Each platform with a crane shall paint, in **RED**, a perimeter line near the pedestal indicating the area in which the high angle boom kick-out would be activated or other safety devices for the boom.
- NO** part of the load shall enter within this perimeter at any time unless all of the following are completed:
 - . o Obtain written approval from MAPP Field Foreman or Crane Maintenance Foreman;
 - . o JSA must be performed
 - . o Establish a designated spotter to ensure that the crane operator stays clear of the boom stops.
 - . o Place the system in override position if necessary to safely position/move the load.

NSL Slinging Tubulars section (2012 version) "The guidance on the following pages has been reproduced with the written permission of NSL."

APPENDIX J

NSL Slinging Tubulars section (2012 version)

24.0 SLINGING GUIDELINES

24.1 These are general guidelines, the majority of which are pertinent to all types of slings whether constructed from wire rope, alloy chain or man-made fibers. Whichever construction you are using, refer to the relevant section in this handbook for additional information.

Storage

24.2 Wherever possible, all slings should be stored in a warm dry atmosphere either coiled or hanging on purpose made racks. Wire ropes and chain slings should be periodically lubricated to prevent corrosion.

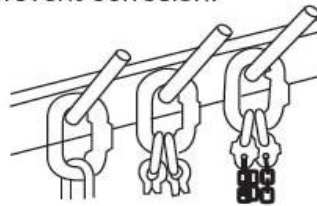
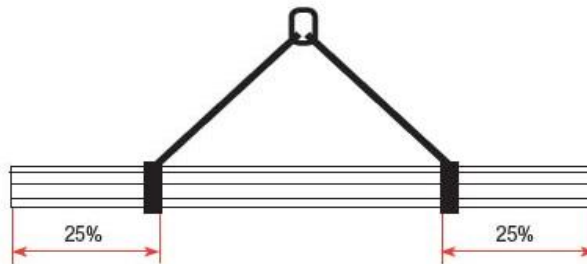

fig 24.1

Slinging Tubulars

24.3 The slinging of tubulars is a very common lifting operation. The slings ideally should be positioned approximately 25% (of the total length) in from either end.



This reduces hogging and sagging to the minimum.

fig 24.2



Industry Practice

Each sling should have a SWL / WLL approximately equal to the gross weight of the load. This allows for down-rating them for the choke hitch, the extra stress in the sling due to the bulldog grip, the lifting angle of the pair of slings and the dynamic / shock-loading when snatching from a supply vessel

- 24.4 The slings must be double wrapped with a choke hitch taking care not to cross over the wires on the underside of the pipe or tube bundle. The choke hitch should be pulled tight to contain the bundle and secured using a bulldog grip and tie wrap. Torque values are not relevant in this application but **be careful not to over-tighten the grips to the extent where they damage the ropes.**

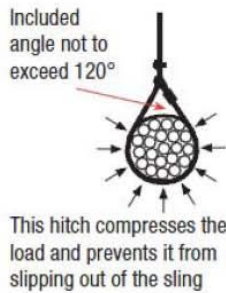
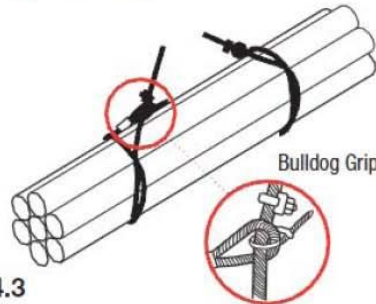

fig 24.3



Tie wraps are not required when clamps used in the Bulldog Grip configuration are too large to fit through the sling eye.

- 24.5 If you are lifting the bundle a number of times with the slings in choke hitch, they will tend to slide towards the center each time the load is lifted and the load can become unbalanced. Ensure they remain correctly positioned i.e. approx. 25% in from either end. Keep your hands and fingers clear of the tubes and the slings as the load is taken.

WARNING! WARNING! WARNING! WARNING!

Although it is deemed acceptable to SINGLE wrap and choke INDIVIDUAL tubulars, this is only recommended under ideal conditions. In all other cases where outside influences can affect the safety of the lift, e.g. offset center of gravity, lifting on a vessel where the load is liable to swing, lifting in windy conditions, lifting in confined spaces, lifting excessive heights, etc. it is recommended that these tubulars are also double wrapped.

Always

- 24.6 Prepare your landing site to enable the bundles to be landed without crushing the slings.

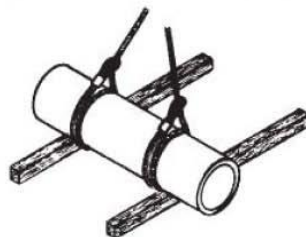

fig 24.4

APPENDIX J – CONTINUED

Always

- 24.7** When stacking tubulars, insert timber packing or similar to prevent damaging the slings.

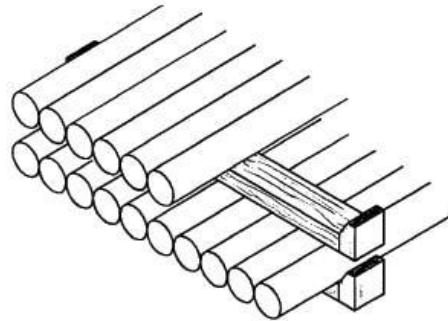

fig 24.5

Never

24.8

- i) Sling tubes of different diameters.
- ii) Sling a mixture of tubulars, angle, flat bar, etc. (in both cases the smaller items will slip out).
- iii) Tighten the choke by hammering as this will increase the effective sling angle thus weakening the sling.

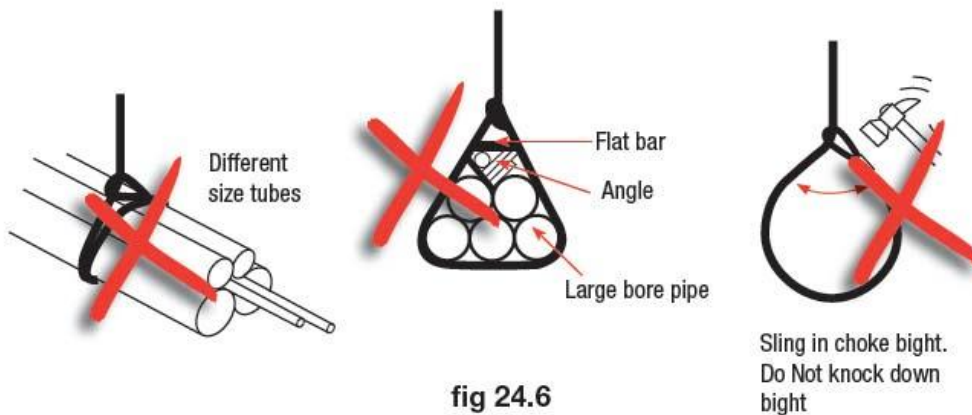

fig 24.6

APPENDIX K

Medical Evaluation For Equipment Operators Fitness Determination

1. OPERATOR'S INFORMATION (Operator completes Sections 1 and 2)

Operator's Name (Last, First, Middle)	Social Security No.	Birth date (mm/dd/yy)	Age	<input type="checkbox"/> M <input type="checkbox"/> F	<input type="checkbox"/> New Qualification <input type="checkbox"/> Re-qualification
Address	City, State, Zip Code	Work Phone: ())	Home Phone: ())		Job Site:

2. HEALTH HISTORY

Yes	No	Yes	No	Yes	No
<input type="checkbox"/>	<input type="checkbox"/>	<input type="checkbox"/>	<input type="checkbox"/>	<input type="checkbox"/>	<input type="checkbox"/>
Any illness or injury in last 5 years?		Lung disease, emphysema, asthma, chronic bronchitis		Fainting, dizziness	
<input type="checkbox"/>	<input type="checkbox"/>	<input type="checkbox"/>	<input type="checkbox"/>	<input type="checkbox"/>	<input type="checkbox"/>
Head/Brain injuries, disorders or illnesses		Kidney disease, dialysis		Sleep disorders, pauses in breathing while asleep, daytime sleepiness	
<input type="checkbox"/>	<input type="checkbox"/>	<input type="checkbox"/>	<input type="checkbox"/>	<input type="checkbox"/>	<input type="checkbox"/>
Seizures, epilepsy		Liver disease		Stroke or paralysis	
<input type="checkbox"/>	<input type="checkbox"/>	<input type="checkbox"/>	<input type="checkbox"/>	<input type="checkbox"/>	<input type="checkbox"/>
Medication _____		Digestive problems		Missing or impaired hand, arm, foot, leg, finger, toe	
<input type="checkbox"/>	<input type="checkbox"/>	<input type="checkbox"/>	<input type="checkbox"/>	<input type="checkbox"/>	<input type="checkbox"/>
Eye disorders or impaired vision (except corrective lenses)		Diabetes or elevated blood sugar controlled by:		Spinal injury or disease	
<input type="checkbox"/>	<input type="checkbox"/>	<input type="checkbox"/>	<input type="checkbox"/>	<input type="checkbox"/>	<input type="checkbox"/>
Ear disorders, loss of hearing or balance		diet		Chronic low back pain	
<input type="checkbox"/>	<input type="checkbox"/>	<input type="checkbox"/>	<input type="checkbox"/>	<input type="checkbox"/>	<input type="checkbox"/>
Heart disease or heart attack, other cardiovascular condition		pills		Regular, frequent alcohol use	
<input type="checkbox"/>	<input type="checkbox"/>	<input type="checkbox"/>	<input type="checkbox"/>	<input type="checkbox"/>	<input type="checkbox"/>
Medication _____		insulin		Narcotic or habit forming drug use	
<input type="checkbox"/>	<input type="checkbox"/>	<input type="checkbox"/>	<input type="checkbox"/>	<input type="checkbox"/>	<input type="checkbox"/>
Heart surgery (valve replacement/bypass, angioplasty, pacemaker)		Nervous or psychiatric disorders, e.g., severe depression		Muscular disease	
<input type="checkbox"/>	<input type="checkbox"/>	<input type="checkbox"/>	<input type="checkbox"/>	<input type="checkbox"/>	<input type="checkbox"/>
High blood pressure		Medication _____		Shortness of breath	
<input type="checkbox"/>	<input type="checkbox"/>	<input type="checkbox"/>	<input type="checkbox"/>		
Medication _____		Loss of, or altered, consciousness			

For any YES answer, indicate onset date, diagnosis, treating physician's name and address, any current limitation. List all medications (including over-the-counter medications) used regularly or recently.

--

The above information is complete and true. I understand that inaccurate, false, or missing information may invalidate the medical evaluation and my status as a Qualified Equipment Operator.

Operator's Signature: _____

Date: _____

3. VISION

ACUITY	UNCORRECTED	CORRECTED
Right Eye	20/	20/
Left Eye	20/	20/
Both Eyes	20/	20/

Vision Technician Signature

Date

Vision of at least 20/30 Snellen in one eye and 20/50 in the other, with or without corrective lenses.

4. OCCUPATIONAL HEALTH SERVICES

- Qualified, no follow-up needed
 Qualified after follow-up
 Qualified with the following restrictions
 Referred to Dr. for follow-up (Name, Address, Phone)
 Not qualified

OHS Reviewer's Signature: _____

Date: _____